



US0D1019704S

(12) **United States Design Patent** (10) **Patent No.:** **US D1,019,704 S**  
**Becker** (45) **Date of Patent:** **\*\* Mar. 26, 2024**

- (54) **RAM-AIR INTAKE**
- (71) Applicant: **Velossa Tech Engineering Inc.**, Davie, FL (US)
- (72) Inventor: **Dan Joseph Becker**, Davie, FL (US)
- (73) Assignee: **Velossa Tech Engineering, Inc.**, Davie, FL (US)
- (\*\*) Term: **15 Years**
- (21) Appl. No.: **29/817,918**
- (22) Filed: **Dec. 6, 2021**

5,722,358 A 3/1998 Fuesser et al.  
 D453,774 S \* 2/2002 Garcia ..... D15/5  
 6,698,539 B2 3/2004 Decuir  
 7,114,476 B1 10/2006 Wimmer  
 (Continued)

**FOREIGN PATENT DOCUMENTS**

DE 102005040850 A1 3/2007  
 EP 0867608 A2 9/1998  
 (Continued)

**OTHER PUBLICATIONS**

Copending Design U.S. Appl. No. 29/817,920, filed Dec. 6, 2021,  
 Inventor: Dan Joseph Becker.  
 (Continued)

**Related U.S. Application Data**

- (63) Continuation of application No. 16/785,609, filed on Feb. 9, 2020.
- (51) **LOC (14) Cl.** ..... **15-01**
- (52) **U.S. Cl.**  
USPC ..... **D15/5**
- (58) **Field of Classification Search**  
USPC ..... D15/1-5; D23/384, 386, 387, 393, 394,  
D23/266, 263, 262, 260, 264  
CPC ..... B60K 13/02; F02M 35/10013; F02M  
35/10262; F02M 35/104; F02M  
35/10026; F02M 35/10078; F02M  
35/10091  
See application file for complete search history.

*Primary Examiner* — Ania Aman  
 (74) *Attorney, Agent, or Firm* — BEKIARES ELIEZER  
 LLP

(57) **CLAIM**

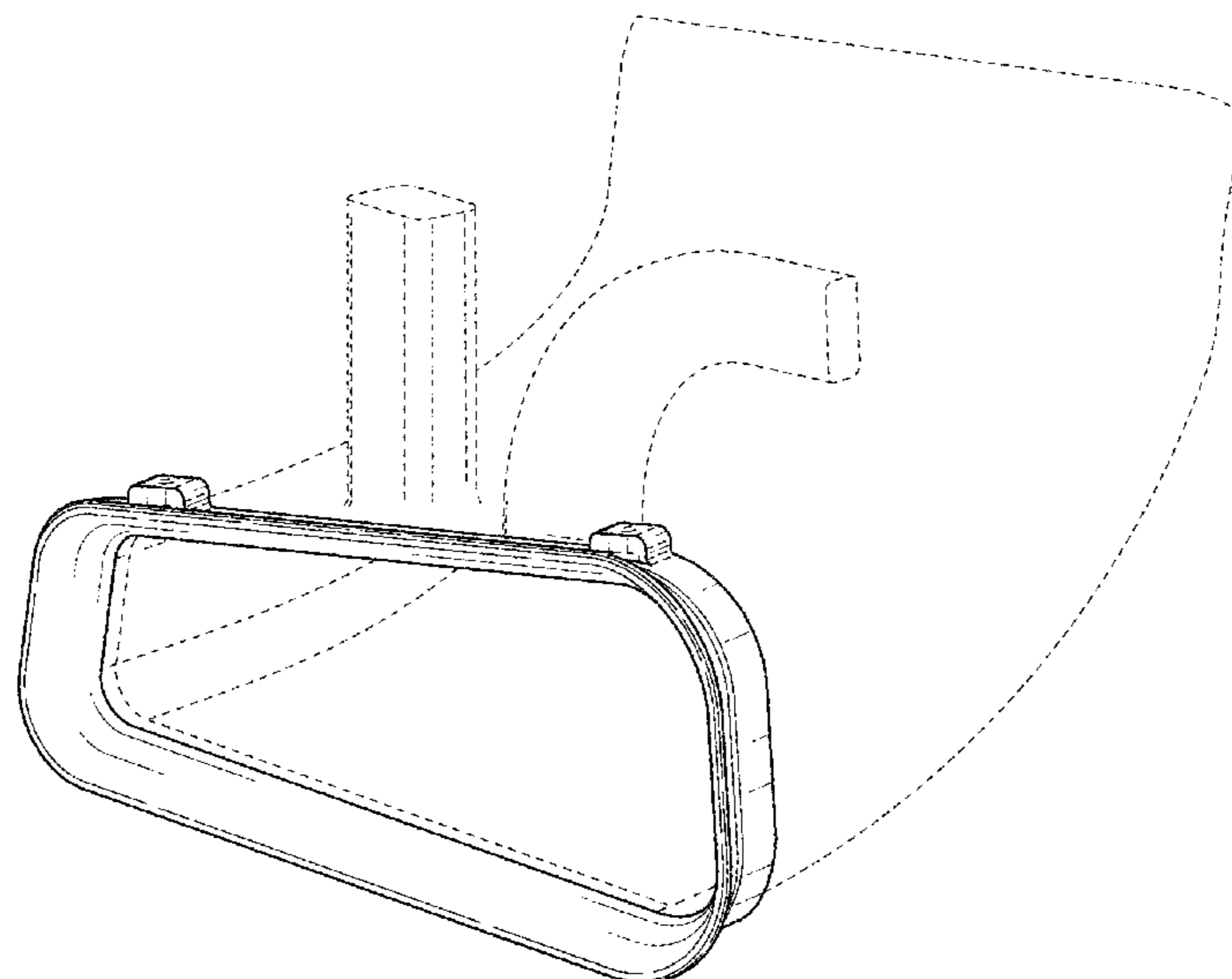
The ornamental design for a ram-air intake, as shown and described.

**DESCRIPTION**

FIG. 1 is a perspective view of a ram-air intake showing my new design;  
 FIG. 2 is a first side view thereof;  
 FIG. 3 is a second side view thereof;  
 FIG. 4 is a top view thereof;  
 FIG. 5 is a bottom view thereof;  
 FIG. 6 is a back view thereof;  
 FIG. 7 is a front view thereof; and,  
 FIG. 8 is a front view showing the ram-air intake in use.  
 The broken lines illustrate portions of the ram-air intake that do not form a part of the claimed design. The embodiment shown is for the left side of a vehicle. The invention includes mirror images of the ram-air intake shown in the Figures.

**1 Claim, 8 Drawing Sheets**

- (56) **References Cited**  
U.S. PATENT DOCUMENTS
- |             |         |                   |
|-------------|---------|-------------------|
| 2,114,783 A | 4/1938  | Kowitt            |
| 3,485,252 A | 12/1969 | Brown             |
| 4,610,326 A | 9/1986  | Kirchweger et al. |
| 4,782,912 A | 11/1988 | Wandless          |
| 5,069,298 A | 12/1991 | Titus             |
| 5,134,977 A | 8/1992  | Bagger et al.     |
| 5,147,430 A | 9/1992  | Kidd              |
| 5,251,712 A | 10/1993 | Hayashi et al.    |



(56)

References Cited

U.S. PATENT DOCUMENTS

8,418,791 B2 \* 4/2013 Matsuda ..... B60K 13/02  
180/68.3

8,960,347 B2 2/2015 Bennett

9,062,639 B1 6/2015 MacKenzie et al.

D762,247 S \* 7/2016 Niakan ..... D15/5

D762,736 S 8/2016 Niakan et al.

9,574,790 B2 2/2017 Hasegawa et al.

D810,141 S 2/2018 Ouellette

9,909,542 B2 3/2018 Rother

D846,087 S \* 4/2019 Naber ..... D23/259

10,393,076 B1 8/2019 Freeman et al.

10,428,773 B1 10/2019 Bennett et al.

D886,868 S 6/2020 Niakan et al.

D911,393 S 2/2021 Niakan et al.

2001/0013675 A1 8/2001 Nakagawa et al.

2001/0018022 A1 \* 8/2001 Nakamura ..... F04D 29/545  
415/203

2002/0033010 A1 \* 3/2002 Schorn ..... F02M 35/04  
55/385.3

2004/0094111 A1 5/2004 Concialdi

2004/0139708 A1 7/2004 Giacinto

2005/0215191 A1 9/2005 Kino

2006/0006011 A1 1/2006 Khouw et al.

2006/0006012 A1 1/2006 Khouw et al.

2009/0151308 A1 \* 6/2009 Jung ..... F02M 35/022  
55/337

2009/0255501 A1 10/2009 Honzawa et al.

2010/0032220 A1 2/2010 Ohira et al.

2010/0083928 A1 4/2010 Saito et al.

2010/0089355 A1 \* 4/2010 Fredrickson ..... F02M 35/162  
123/184.48

2010/0147243 A1 6/2010 Stec et al.

2010/0229817 A1 9/2010 Hirai

2012/0145272 A1 6/2012 Chu et al.

2012/0152632 A1 6/2012 Azuma

2015/0233329 A1 8/2015 Morey

2015/0240760 A1 8/2015 Lewington et al.

2017/0072785 A1 3/2017 Cho

2017/0113758 A1 4/2017 Hamaguchi et al.

2017/0114704 A1 4/2017 Morey

2017/0260939 A1 9/2017 Williams

2018/0043765 A1 \* 2/2018 Niessen ..... F02M 35/10091

2018/0100473 A1 4/2018 Kimura

2018/0112635 A1 4/2018 Cho

2018/0372038 A1 12/2018 McCann et al.

2019/0100073 A1 \* 4/2019 Link ..... B60H 1/00271

2019/0184787 A1 6/2019 Hurd, III et al.

2019/0388820 A1 12/2019 Niakan et al.

2020/0032747 A1 1/2020 Gobbato et al.

2020/0079258 A1 3/2020 Kikuchi et al.

2020/0132025 A1 4/2020 Williams et al.

2020/0340433 A1 10/2020 Kimura

2021/0017940 A1 1/2021 McCann et al.

2021/0190019 A1 \* 6/2021 Vite Cadena .... F02M 35/10006

2021/0246855 A1 8/2021 Becker

2021/0381476 A1 12/2021 Karlsson

2022/0145835 A1 5/2022 Maeda

FOREIGN PATENT DOCUMENTS

EP 2103511 B1 7/2010

FR 2933045 A1 1/2010

JP 6072074 B2 2/2017

WO 2021163711 A1 10/2021

OTHER PUBLICATIONS

Copending Design U.S. Appl. No. 29/817,923, filed Dec. 6, 2021, Inventor: Dan Joseph Becker.

Copending Design U.S. Appl. No. 29/817,926, filed Dec. 6, 2021, Inventor: Dan Joseph Becker.

Copending Design U.S. Appl. No. 29/817,931, filed Dec. 6, 2021, Inventor: Dan Joseph Becker.

U.S. Non-Final Office Action dated Sep. 21, 2021 cited in U.S. Appl. No. 16/785,609, 31 pgs.

International Search Report and Written Opinion dated Nov. 17, 2021 cited in PCT Application No. PCT/US21/26465, 22 pgs.

Video: Velossa Tech Gen 4 Released/Sneak Peak Veloster N Big Mouth With Exchangeable Flares, <https://www.youtube.com/watch?v=DBsfgLQCa6Q>, Feb. 12, 2021, 3 pgs.

Video: Focus ST Velossa Tech Big Mouth Install, <https://www.youtube.com/watch?v=5MfC6K9doZA>, Feb. 19, 2017, 3 pgs.

Generation 4 Interchangeable Big Mouth | Flare/Inlet Only, <https://web.archive.org/web/20201126061651/https://www.velossatechdesign.com/products/generation-4-interchangeable-big-mouth-flare-inlet-only>, Nov. 26, 2020, 3 pgs. (resubmission).

U.S. Non-Final Office Action dated Dec. 22, 2022 cited in U.S. Appl. No. 29/817,920, 21 pgs.

U.S. Non-Final Office Action dated Dec. 22, 2022 cited in U.S. Appl. No. 29/817,923, 23 pgs.

U.S. Non-Final Office Action dated Dec. 22, 2022 cited in U.S. Appl. No. 29/817,926, 21 pgs.

U.S. Non-Final Office Action dated Dec. 22, 2022 cited in U.S. Appl. No. 29/817,931, 20 pgs.

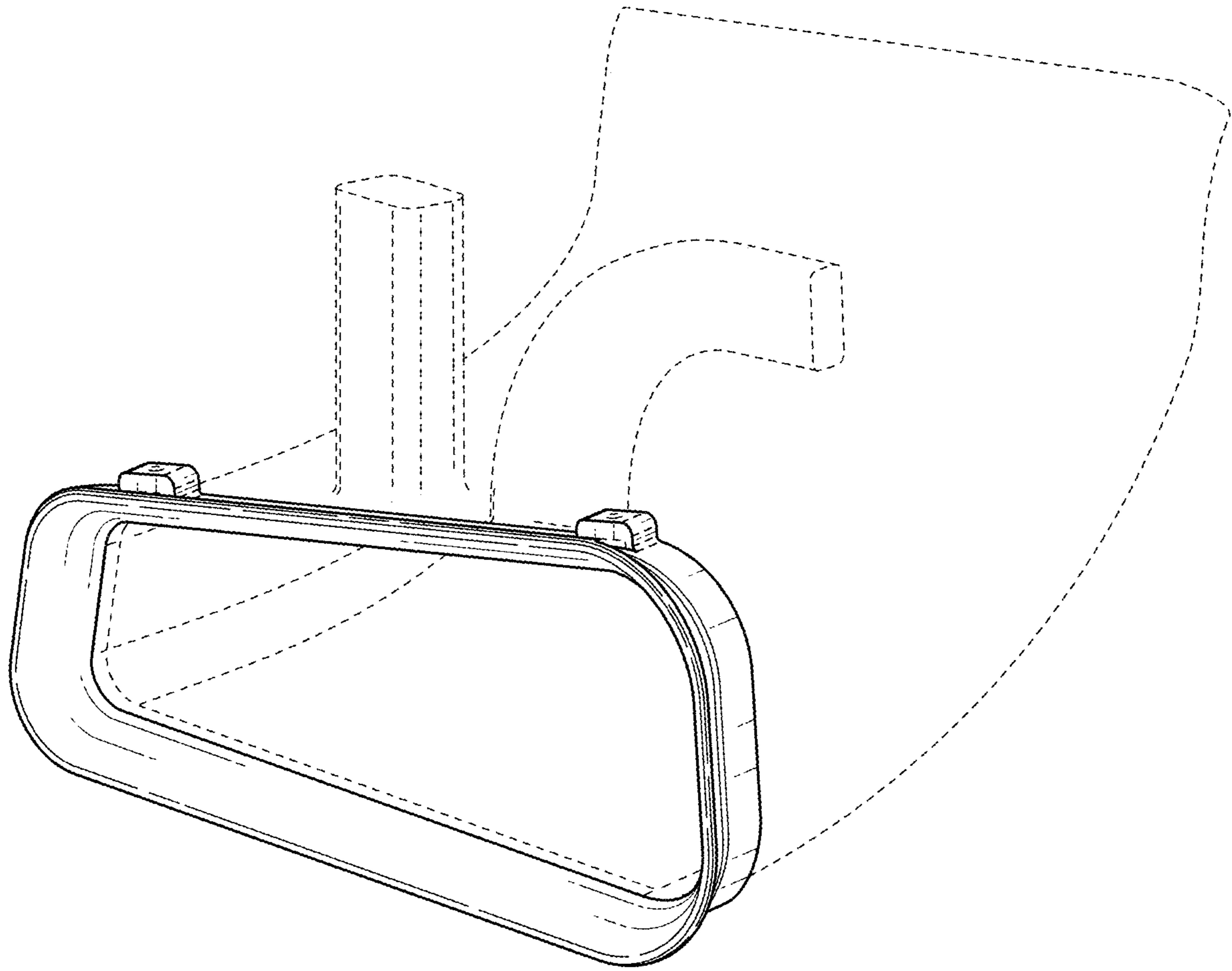
How to Install Big Mouth Ram Air Intake Ford Focus RS, <https://www.youtube.com/watch?v=bwPBelbTamY>. Blake's Garage, Accessed Jan. 3, 2023, published on May 30, 2017 (Intvw Summ dtd Jan. 9, 2023).

Ford Focus Big Mount Intake Snorkel Install !. <https://www.youtube.com/watch?v=oV3E-leEu4>. Cameron Alford. Accessed Jan. 3, 2023, published on Nov. 12, 2019 (Intvw Summ dtd Jan. 9, 2023).

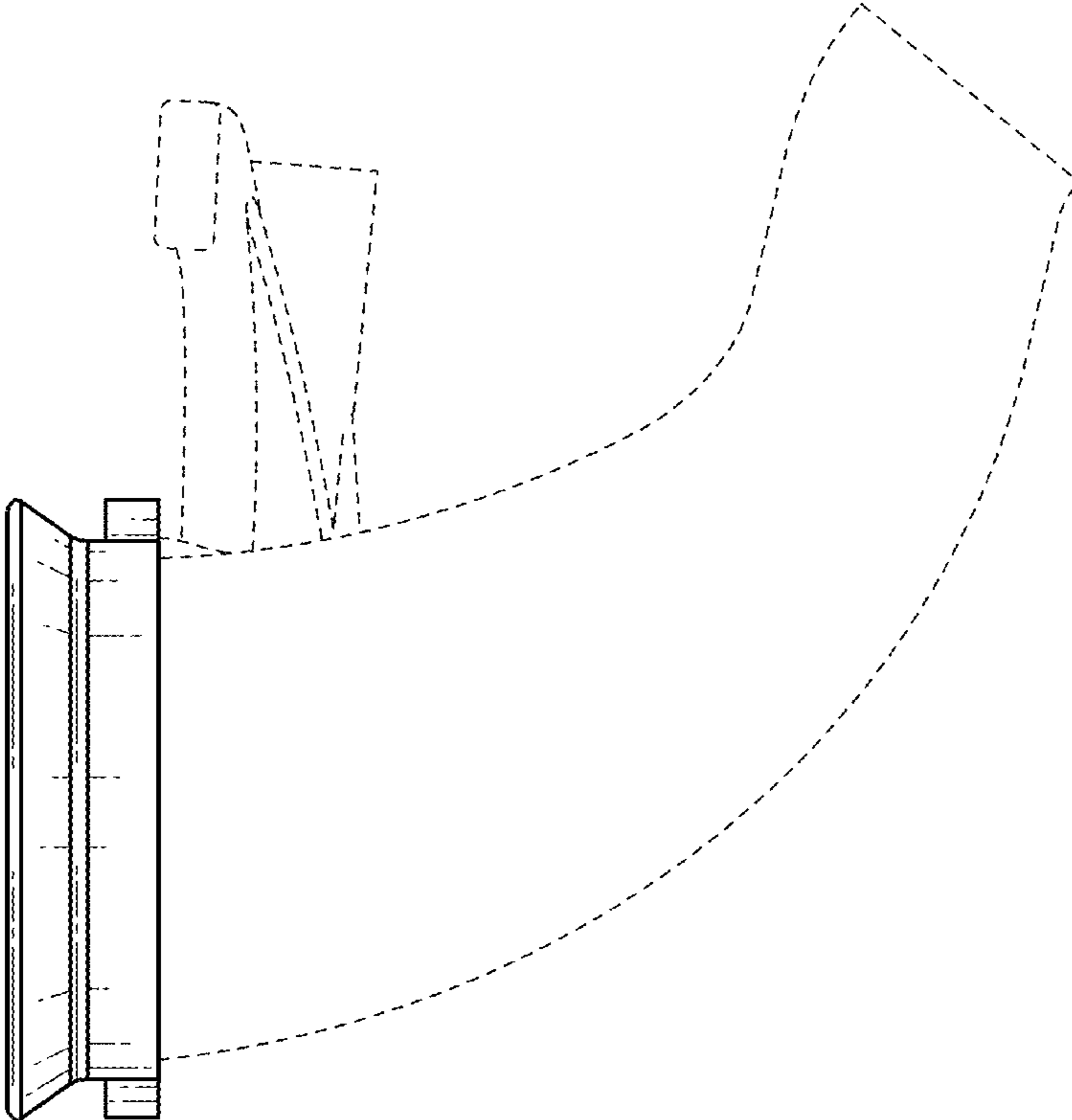
U.S. Non-Final Office Action dated Jan. 23, 2023 cited in U.S. Appl. No. 16/785,609, 41 pgs.

U.S. Non-Final Office Action (Updated) dated Feb. 1, 2023 cited in U.S. Appl. No. 16/785,609, 34 pgs.

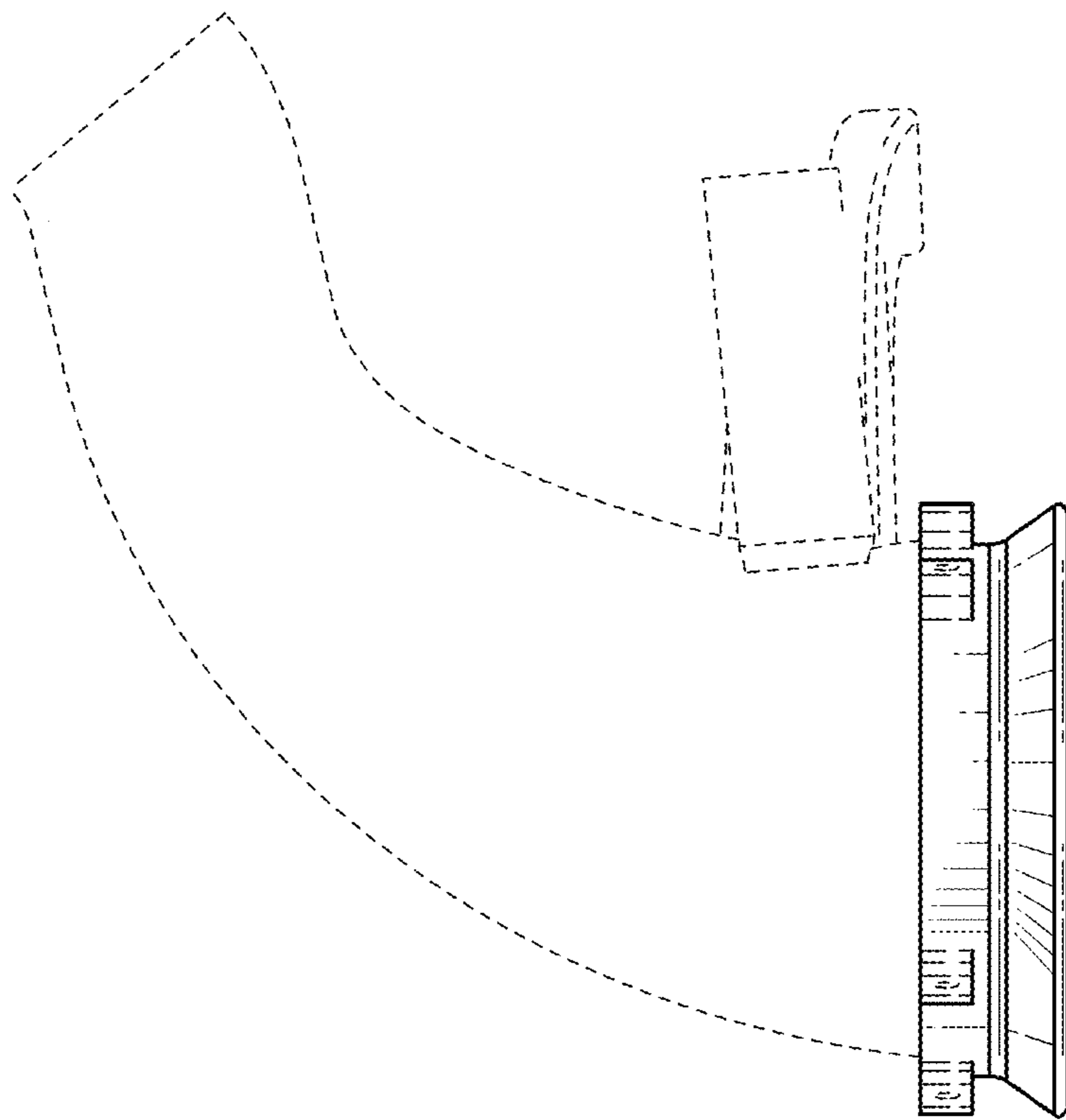
\* cited by examiner



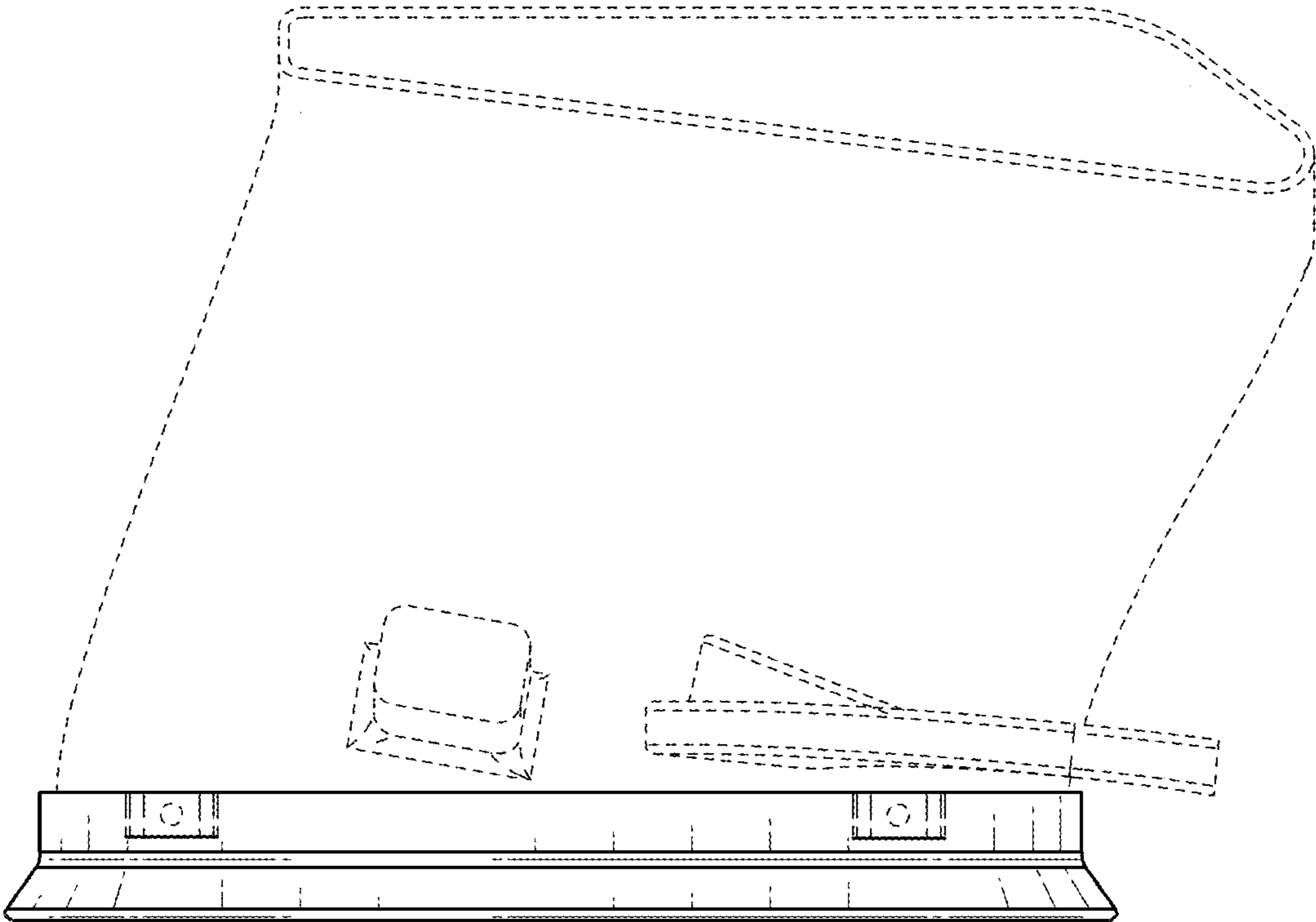
**FIG. 1**



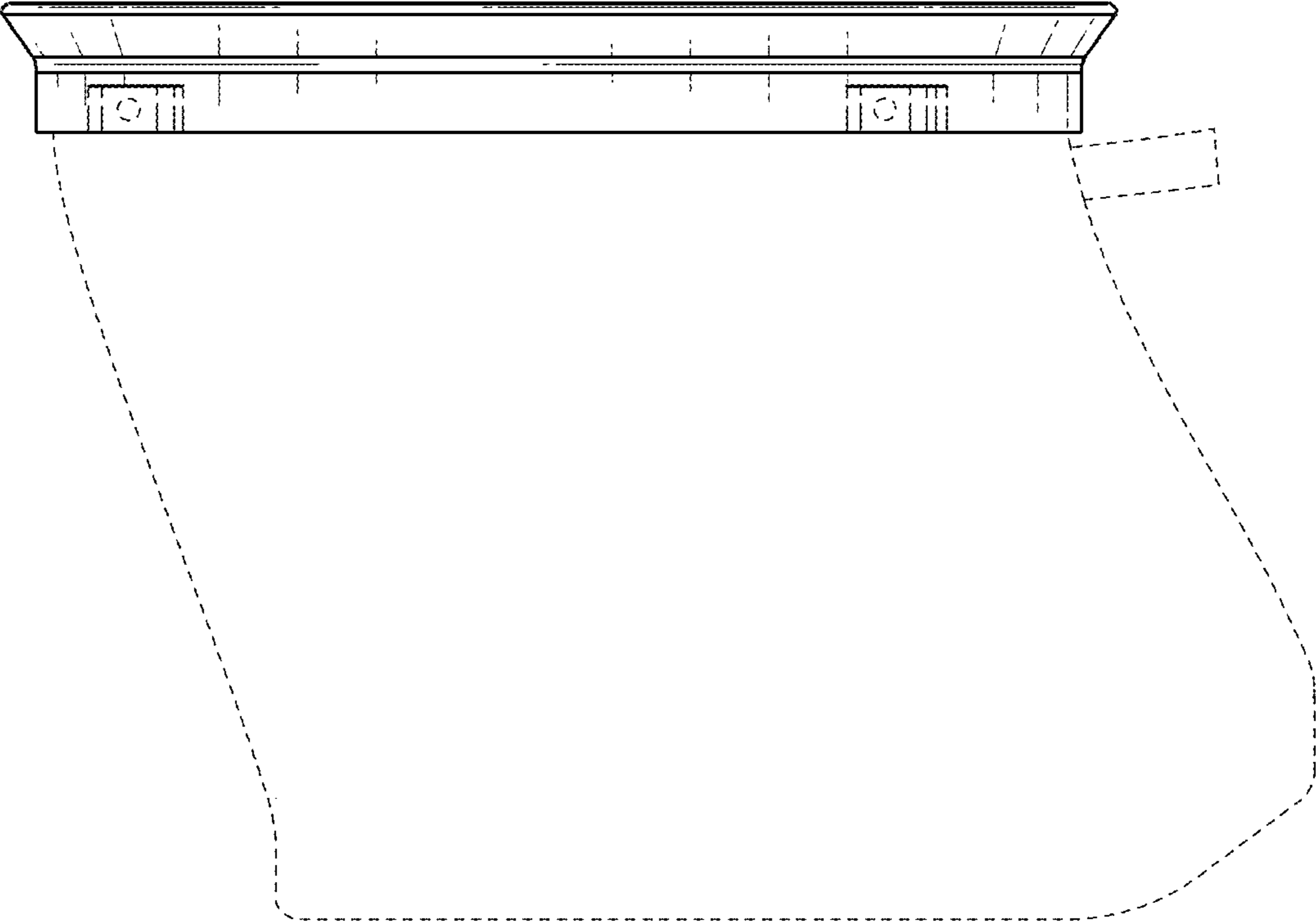
**FIG. 2**



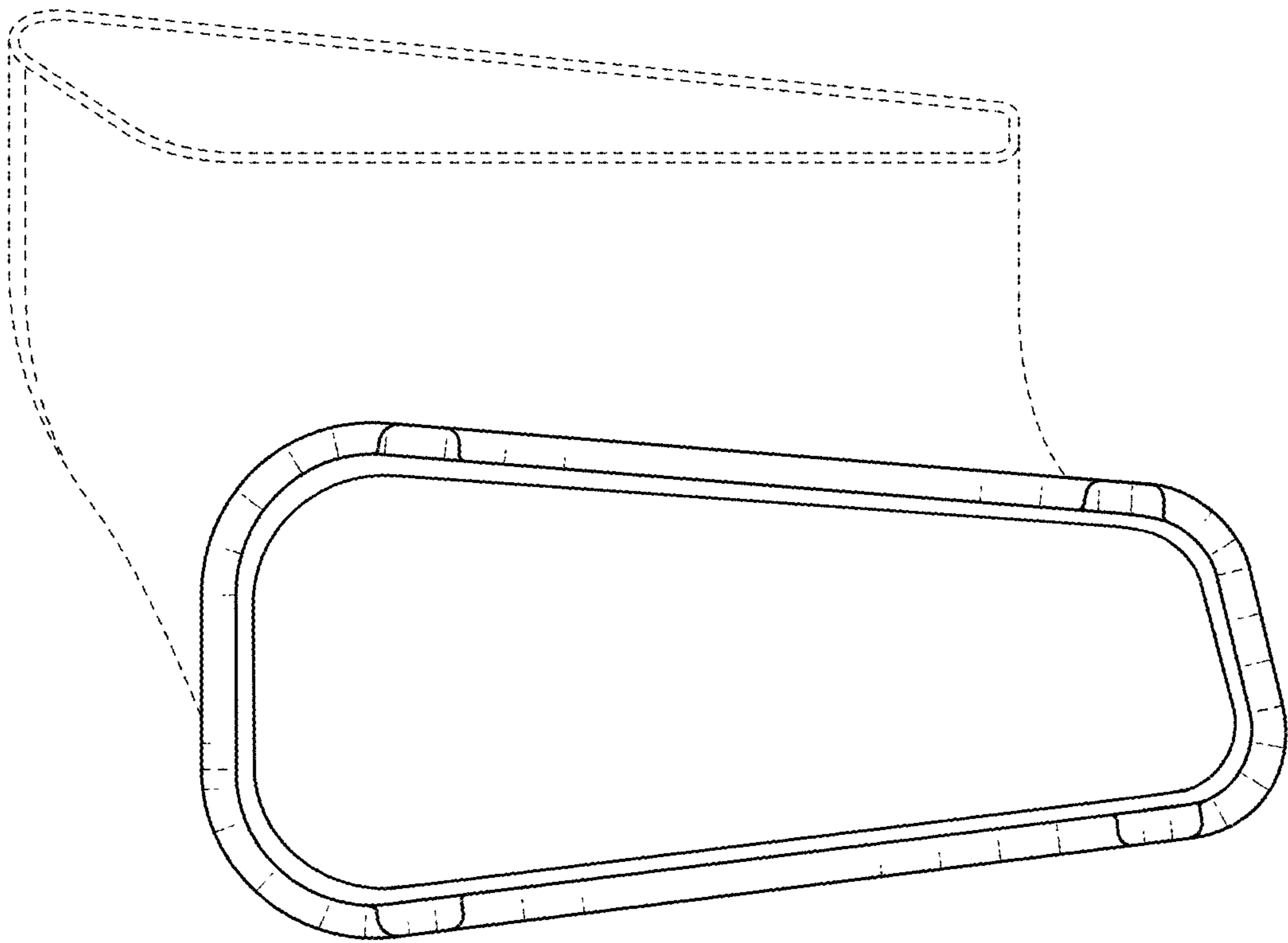
**FIG. 3**



**FIG. 4**

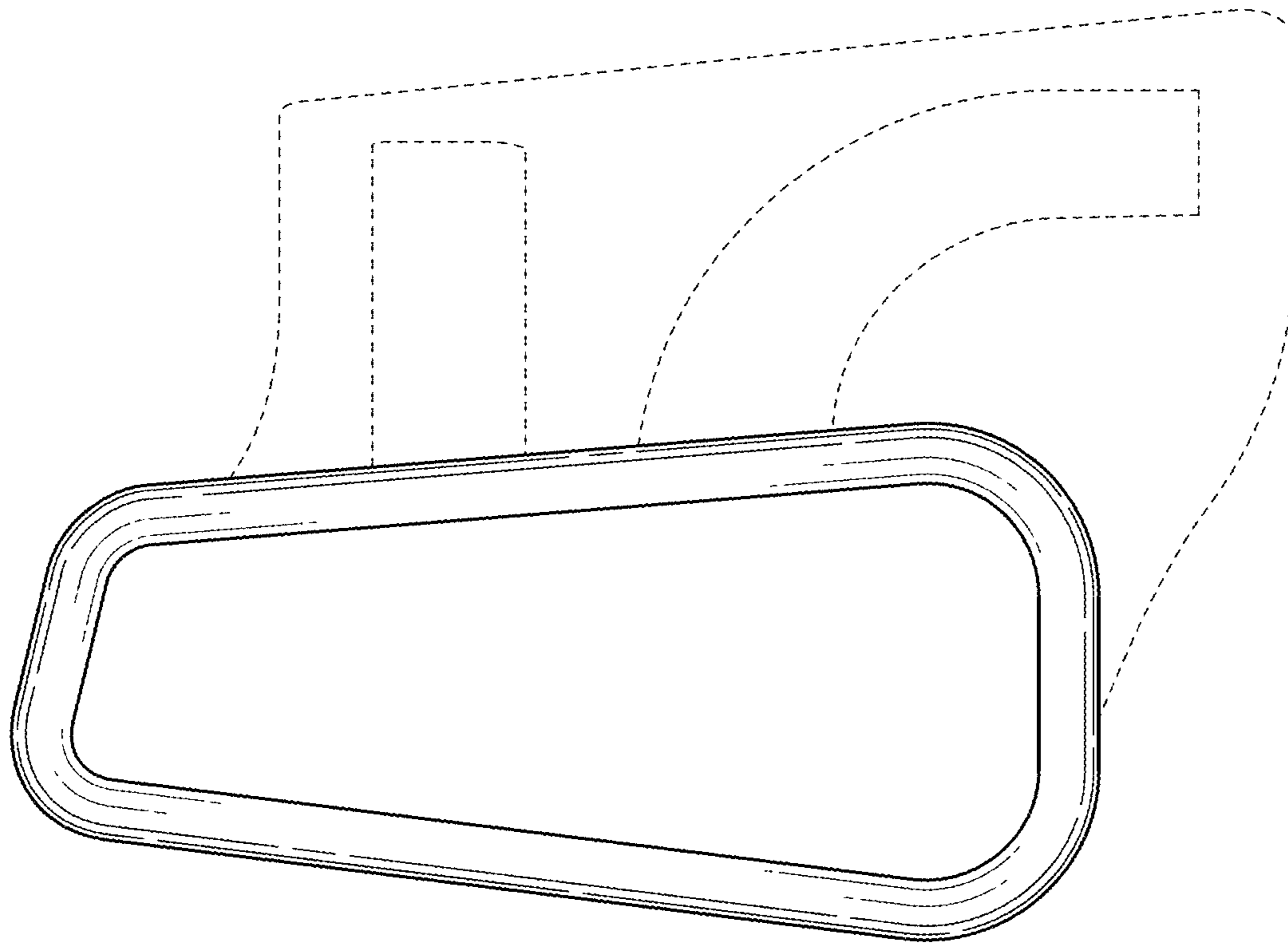


**FIG. 5**

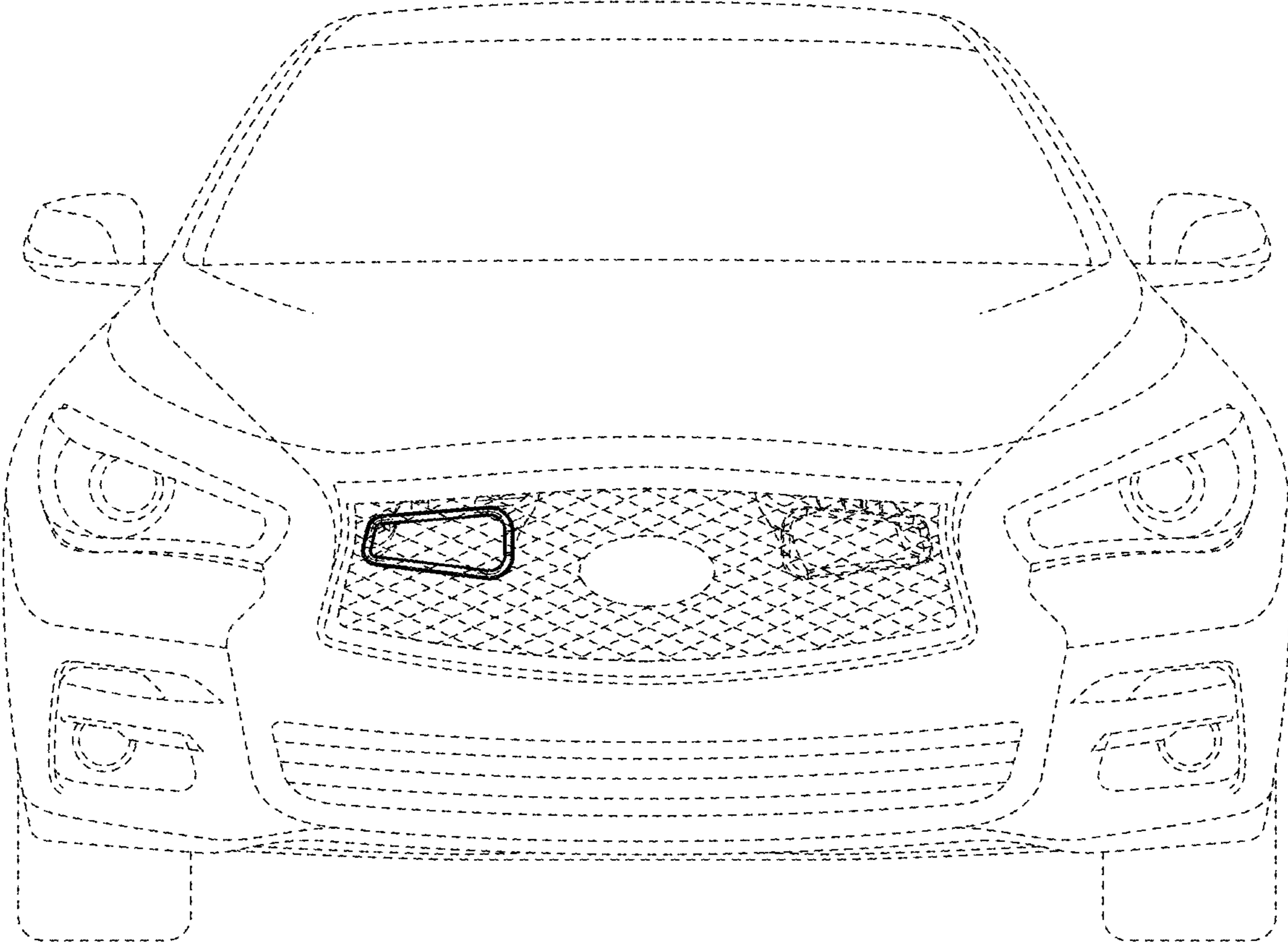


**FIG. 6**





**FIG. 7**



**FIG. 8**