



US0D1012650S

(12) **United States Design Patent**
Zhou et al.

(10) **Patent No.: US D1,012,650 S**

(45) **Date of Patent: ** Jan. 30, 2024**

(54) **PRESSING TOOL**

(71) Applicant: **Ridge Tool Company**, Elyria, OH (US)

(72) Inventors: **Qi Zhou**, Shanghai (CN); **Jinan Chen**, Shanghai (CN)

(73) Assignee: **Ridge Tool Company**, Elyria, OH (US)

(**) Term: **15 Years**

(21) Appl. No.: **29/780,007**

(22) Filed: **Apr. 22, 2021**

(30) **Foreign Application Priority Data**

Dec. 15, 2020 (CN) 202030772026.4

(51) **LOC (14) Cl.** **08-05**

(52) **U.S. Cl.**
USPC **D8/68**

(58) **Field of Classification Search**
USPC D8/51, 61, 68, 69; D21/532
CPC B25D 11/00; B25D 11/06; B25D 16/00;
B25D 2209/00; B25D 2211/00; B25D
2216/00; B25D 2216/0023; B25D
2216/003; B25D 17/00; B25D 17/04;
B25F 5/00; B25F 5/005; B25F 5/006;
B25F 5/02; B25B 27/026; B25B 27/10;
B25B 27/146; B21D 39/048

See application file for complete search history.

(56) **References Cited**

U.S. PATENT DOCUMENTS

D591,128 S *	4/2009	Chuan	D8/68
D710,173 S *	8/2014	Frenken	D8/68
D845,733 S *	4/2019	Yajima	D8/68
D845,734 S *	4/2019	Kamijo	D8/68
D897,174 S *	9/2020	Könnecke	D8/61
2015/0263472 A1 *	9/2015	Sneath	H01R 43/0427 72/453.16

2018/0099388 A1 *	4/2018	Koski	B23P 19/04
2020/0230797 A1 *	7/2020	Frenken	B25F 5/00
2020/0271249 A1 *	8/2020	Chen	B25B 27/10
2021/0323136 A1 *	10/2021	Hyde	B25F 5/005
2021/0379746 A1 *	12/2021	Frenken	B25B 27/026

OTHER PUBLICATIONS

Klauke ESG105, available Jul. 29, 2020 [online], [retrieved Apr. 25, 2023]. Retrieved from internet, <https://www.powerandcables.com/product/product-category/battery-powered-cable-cutting-tool-105mm-klauke-esg105/> (Year: 2020).*

* cited by examiner

Primary Examiner — Calvin E Vansant

Assistant Examiner — Benjamin L. Gray

(74) *Attorney, Agent, or Firm* — Mark Bandy; Rankin Hill & Clark, LLP

(57) **CLAIM**

The ornamental design for an pressing tool, as shown and described.

DESCRIPTION

FIG. 1 is a front perspective view of an embodiment of a pressing tool;

FIG. 2 is a rear perspective view of the pressing tool of FIG. 1;

FIG. 3 is a first side elevational view of the pressing tool of FIG. 1;

FIG. 4 is a second side elevational view of the pressing tool of FIG. 1;

FIG. 5 is a rear end view of the pressing tool of FIG. 1;

FIG. 6 is a front end view of the pressing tool of FIG. 1;

FIG. 7 is a top view of the pressing tool of FIG. 1; and,

FIG. 8 is a bottom view of the pressing tool of FIG. 1.

The broken lines in the figures illustrate portions of the pressing tool but form no part of the claimed design.

1 Claim, 6 Drawing Sheets

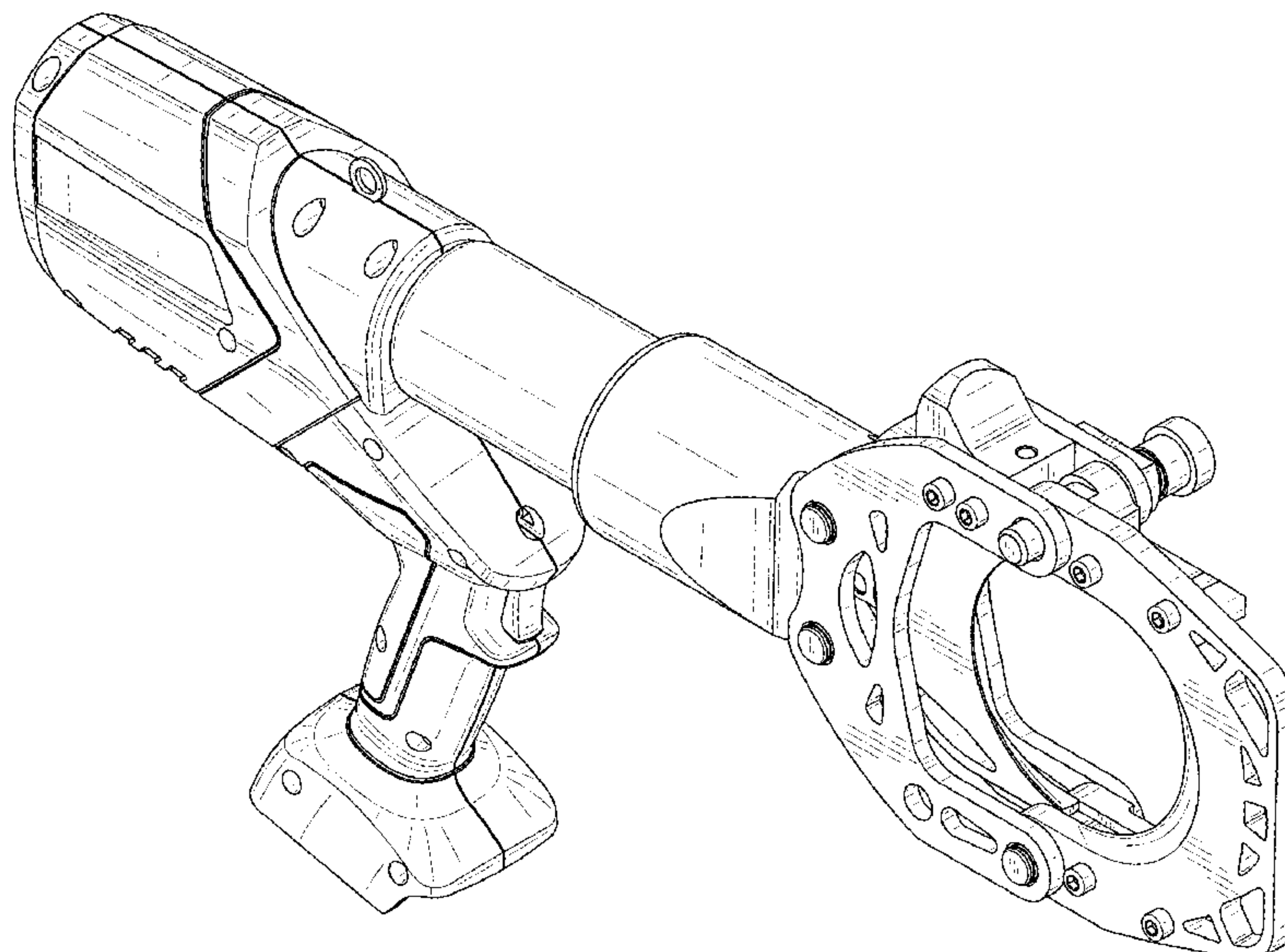

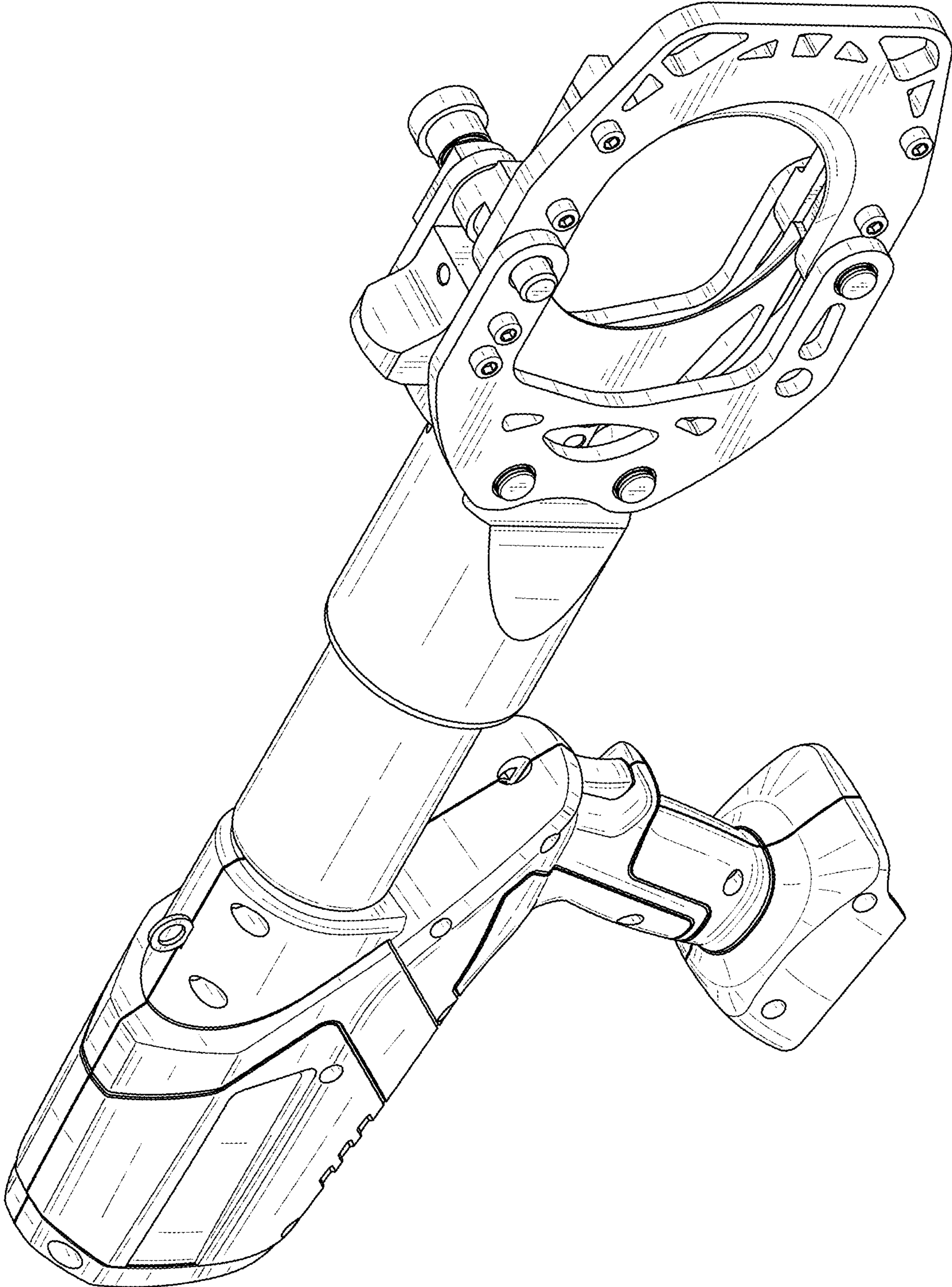

FIG. 1

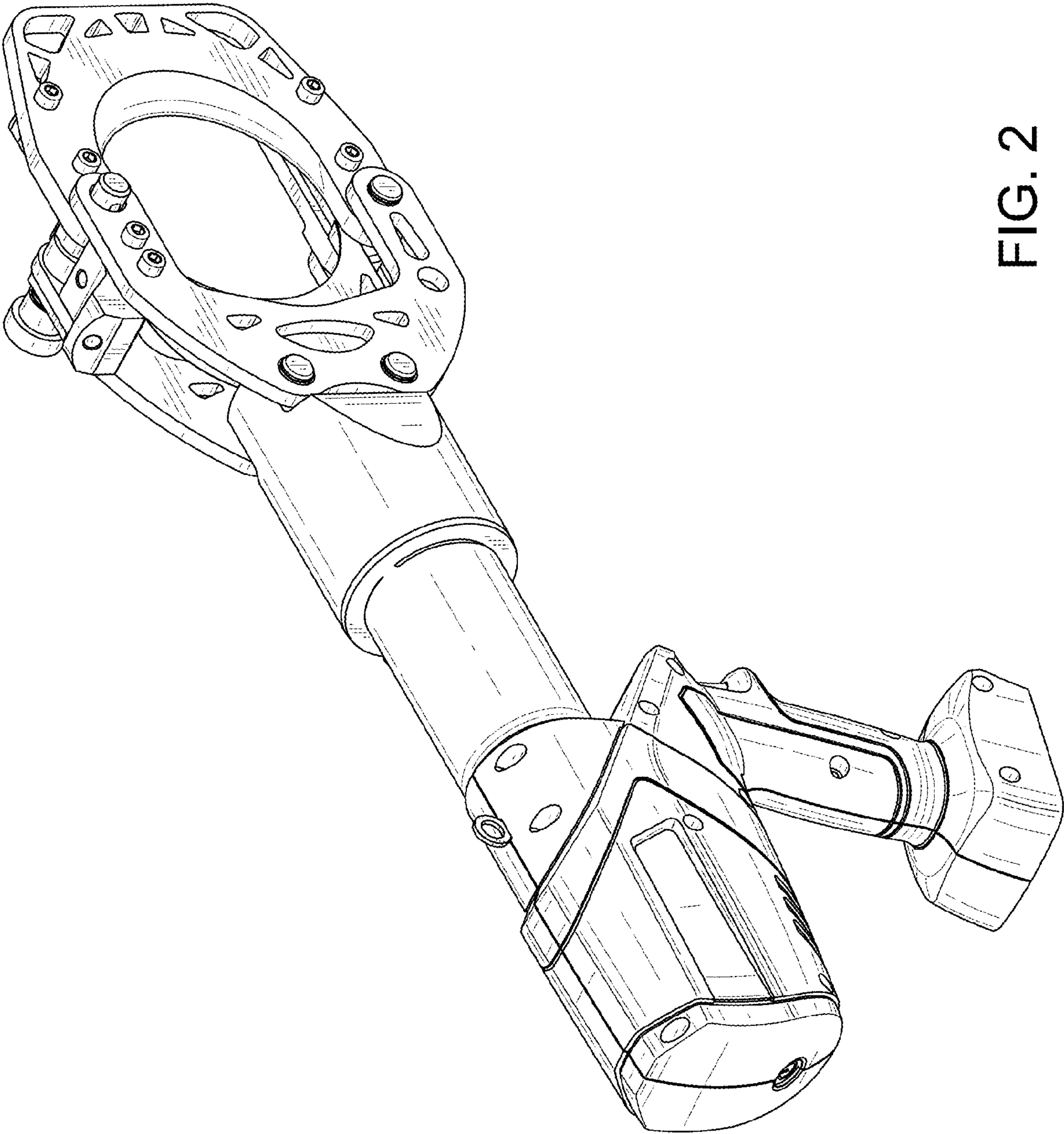

FIG. 2

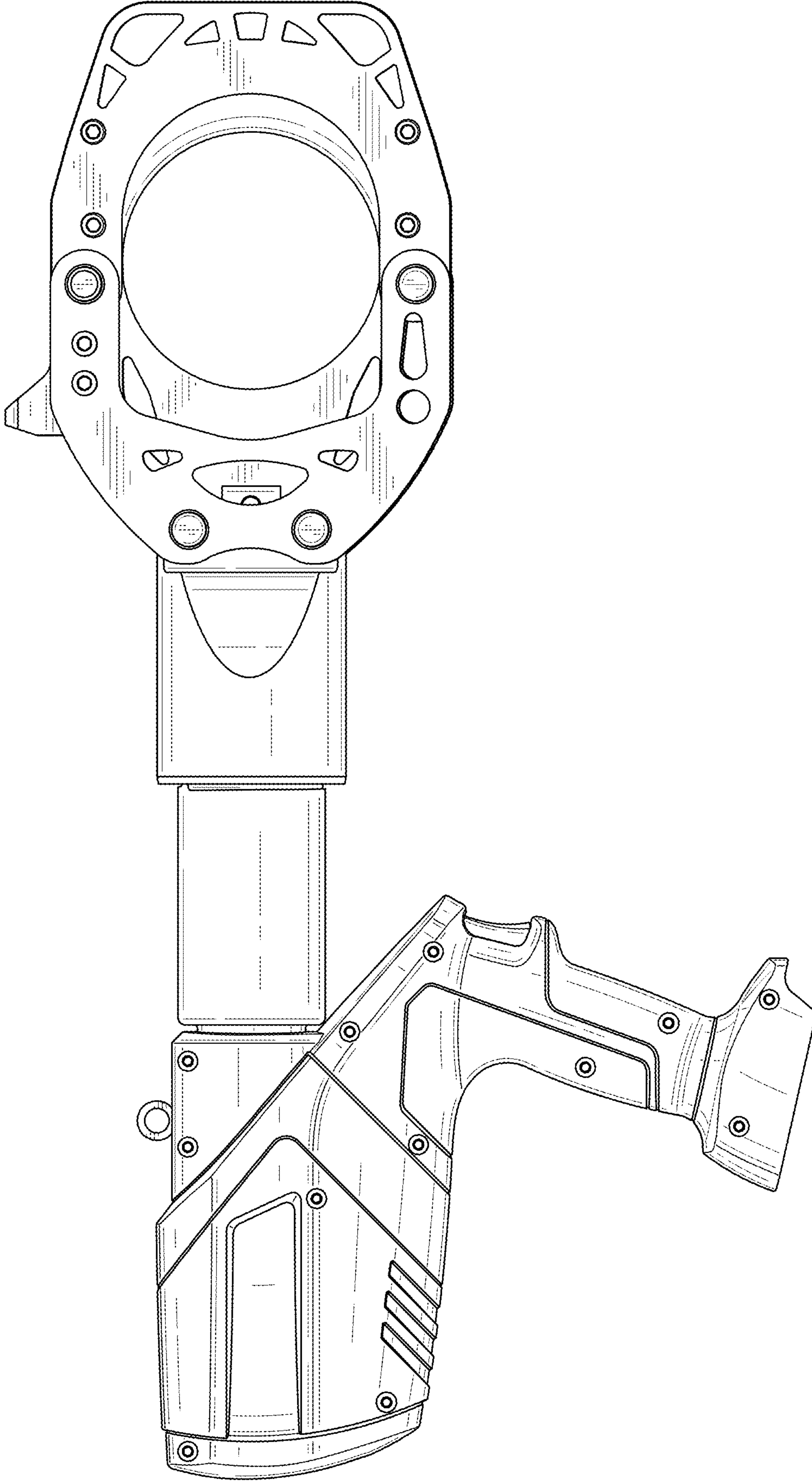

FIG. 3

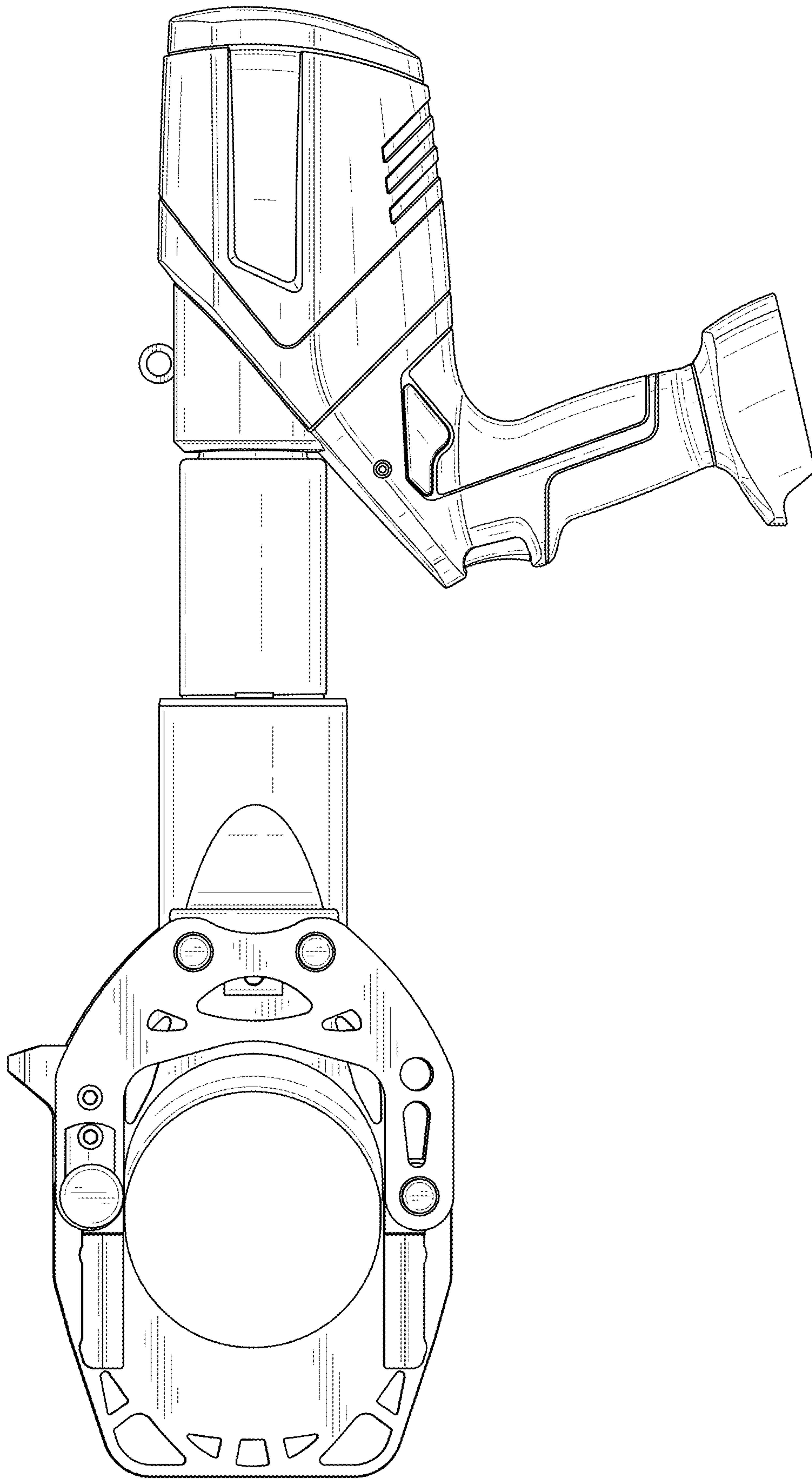

FIG. 4

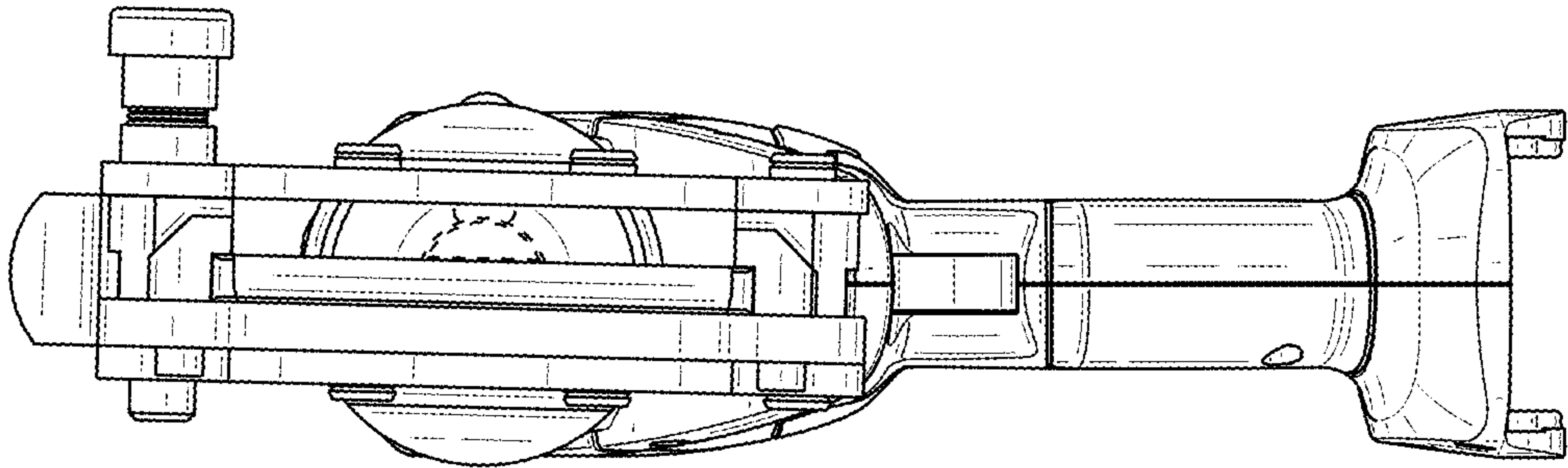

FIG. 6

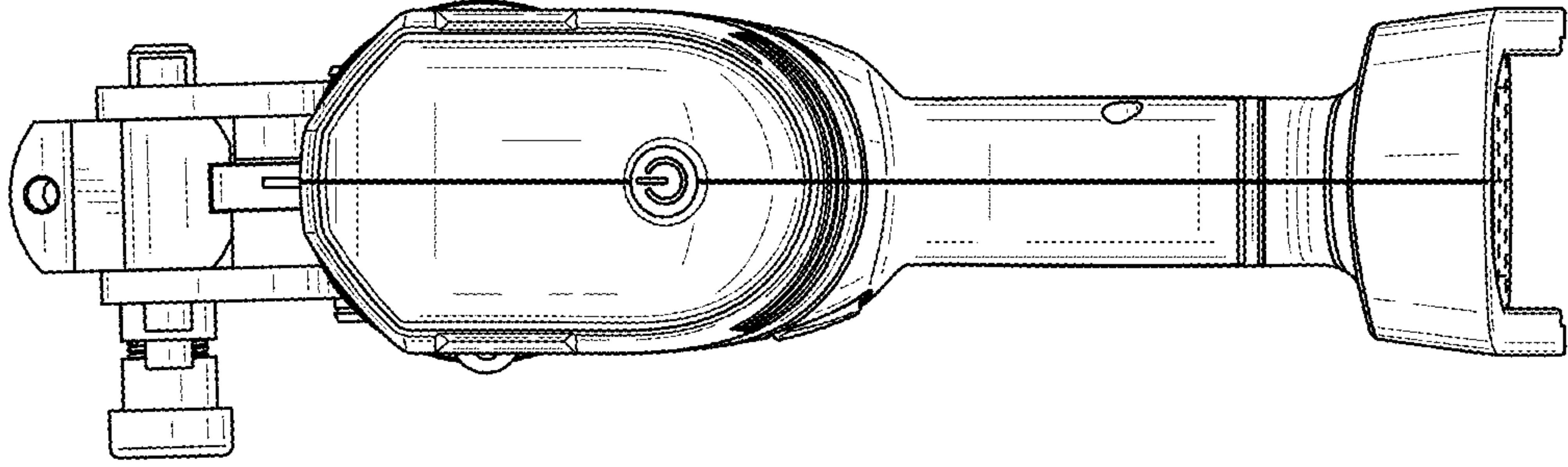

FIG. 5

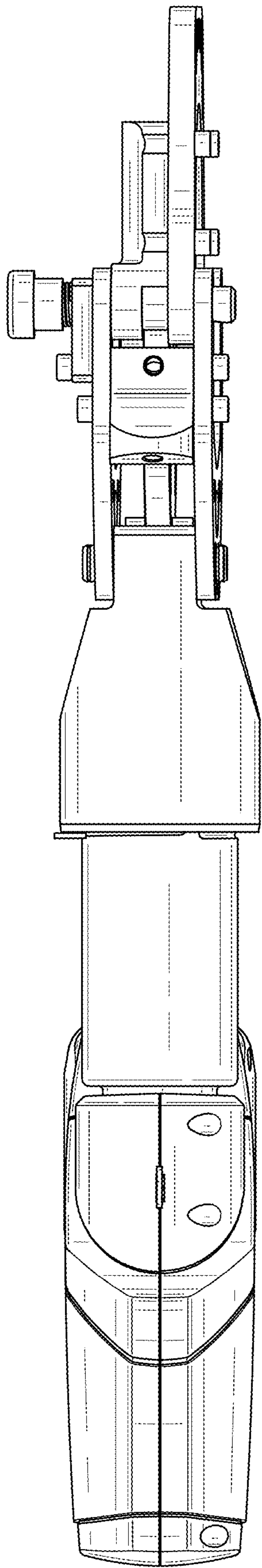

FIG. 7

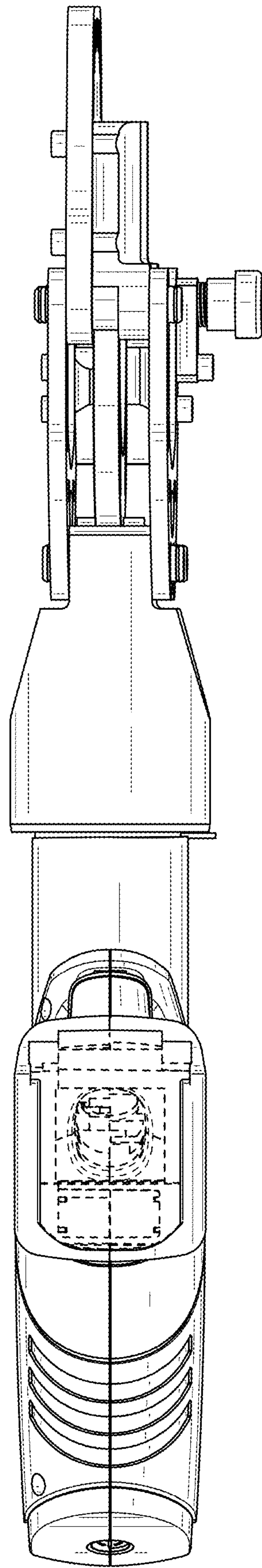

FIG. 8