



US0D1012521S

(12) **United States Design Patent** (10) **Patent No.:** **US D1,012,521 S**
Toll (45) **Date of Patent:** **** Jan. 30, 2024**

(54) **BICYCLE SEAT**
(71) Applicant: **ISM Saddles, LLC**, Lutz, FL (US)
(72) Inventor: **Steven G. Toll**, Lutz, FL (US)
(73) Assignee: **ISM Saddles, LLC**, Lutz, FL (US)
(**) Term: **15 Years**
(21) Appl. No.: **29/846,806**
(22) Filed: **Jul. 19, 2022**
(51) **LOC (14) Cl.** **06-01**
(52) **U.S. Cl.**
USPC **D6/354**
(58) **Field of Classification Search**
USPC D6/340, 354; D12/110, 111
CPC ... B62J 1/002; B62J 1/005; B62J 1/007; B62J
1/26
See application file for complete search history.

623,238 A 4/1899 Davis
629,956 A 8/1899 Craig
635,598 A 10/1899 Rowe
642,191 A 1/1900 Wright
654,720 A 7/1900 Engelbert
701,390 A 6/1902 Provoost
(Continued)

FOREIGN PATENT DOCUMENTS

EP 1444127 11/2004
EP 2910458 8/2015
(Continued)

OTHER PUBLICATIONS

Leibovitch et al., "The Vicious Cycling: Bicycling Related Uro-
genital Disorders", European Urology 47, pp. 277-287 (2005).
(Continued)

Primary Examiner — Natasha Vujcic
(74) *Attorney, Agent, or Firm* — Akerman LLP; Peter A.
Chiabotti

(56) **References Cited**
U.S. PATENT DOCUMENTS

464,653 A 12/1891 Latta
532,444 A 1/1895 Christy
D24,139 S 3/1895 Christy
537,375 A 4/1895 Wright et al.
568,626 A 9/1896 Pierce et al.
570,497 A 11/1896 Pattison
572,062 A 11/1896 Peck
D27,616 S 8/1897 Rusch
D28,433 S 3/1898 Hollenbeck
D28,434 S 3/1898 Hollenbeck
602,732 A 4/1898 Craig
605,151 A 6/1898 Twist
608,682 A 8/1898 Jamieson
612,552 A 10/1898 Standeford
612,972 A * 10/1898 Leech B62J 1/002
297/202
D29,719 S 11/1898 Leech et al.
619,204 A 2/1899 Moore
622,357 A 4/1899 Hitchcock et al.

(57) **CLAIM**

The ornamental design for a bicycle seat, as shown and
described.

DESCRIPTION

FIG. 1 is a perspective view of a bicycle seat showing my
new design;
FIG. 2 is a front elevation view thereof;
FIG. 3 is a rear elevation view thereof;
FIG. 4 is a right side elevation view thereof;
FIG. 5 is a left side elevation view thereof;
FIG. 6 is a top plan view thereof; and,
FIG. 7 is a bottom view thereof.
The portions shown in broken lines form no part of the
claimed design.

1 Claim, 6 Drawing Sheets

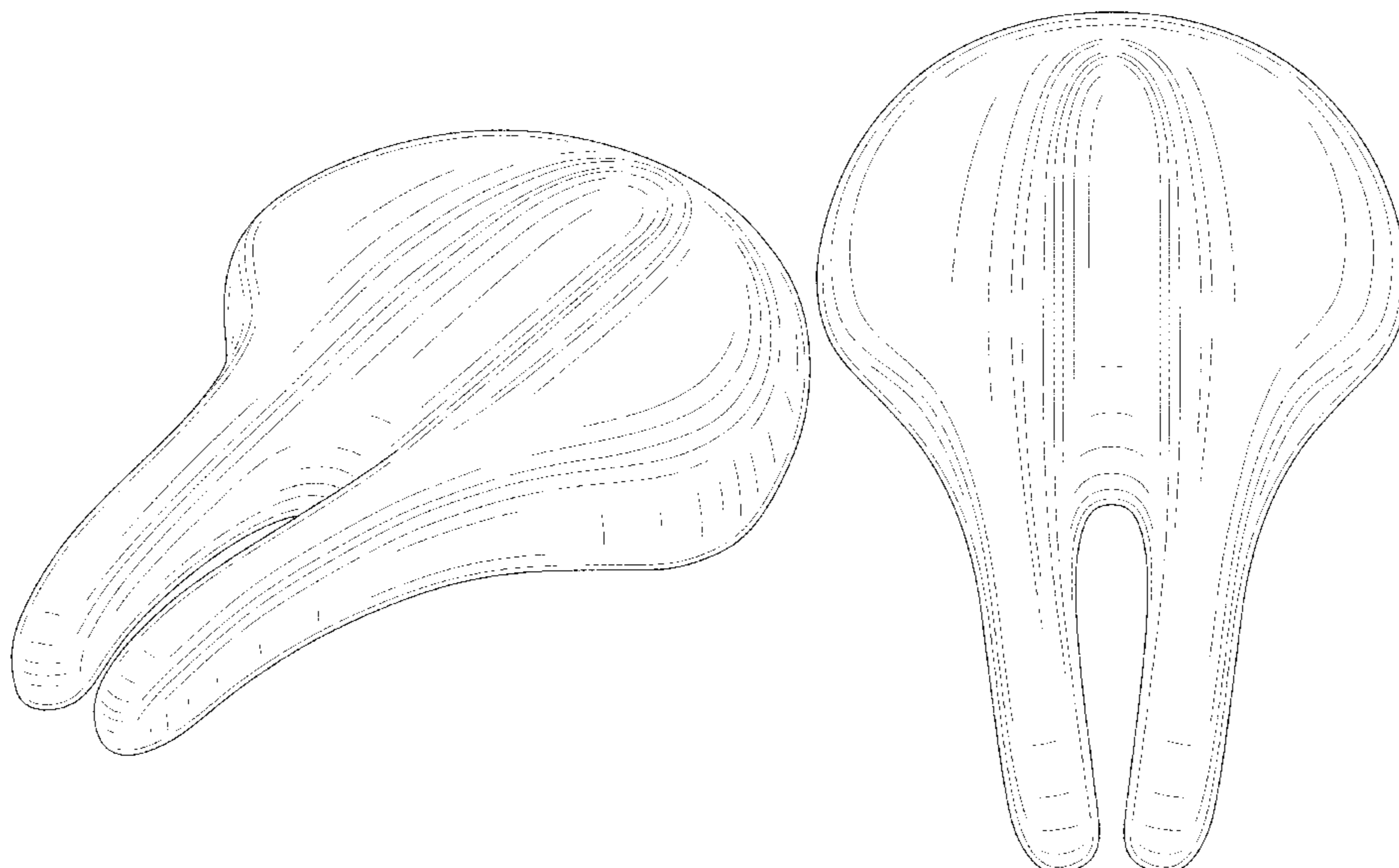

(56)

References Cited

U.S. PATENT DOCUMENTS

872,124 A	11/1907	Hammaren	D604,057 S	11/2009	Toll
1,462,976 A	9/1922	Mesinger	7,699,391 B2	4/2010	Riondato
1,538,542 A *	5/1925	Blake B62J 1/02 297/202	D622,973 S	9/2010	Toll
1,858,477 A	5/1932	Blake	7,934,770 B2	5/2011	Toll
D106,117 S	5/1937	Kraeft	D639,081 S	6/2011	Toll
D213,488 S	3/1969	Golden	D640,879 S	7/2011	Curran
3,844,611 A	10/1974	Young	7,976,102 B2	7/2011	Chang
D237,123 S	10/1975	Hogkvist	D642,846 S	8/2011	Parish et al.
4,429,915 A	2/1984	Flager	D658,396 S	5/2012	Sprouse, II
4,451,083 A	5/1984	Marchello	D677,479 S	3/2013	Toll
4,898,422 A	2/1990	West	D684,780 S	6/2013	Toll
D306,378 S	3/1990	Bernardi	D684,781 S	6/2013	Toll
D315,646 S	3/1991	Hood	8,480,169 B2	7/2013	Bailie et al.
4,999,068 A	3/1991	Chiarella	D688,051 S	8/2013	Toll
5,011,222 A	4/1991	Yates et al.	D688,052 S	8/2013	Toll
5,108,076 A	4/1992	Chiarella	D688,477 S	8/2013	Toll
5,167,435 A	12/1992	Aldi	D688,478 S	8/2013	Toll
5,676,420 A	10/1997	Kuipers et al.	D688,479 S	8/2013	Toll
5,765,912 A	6/1998	Bontrager	8,845,018 B2	9/2014	Toll
5,863,094 A	1/1999	Endo	D720,548 S	1/2015	Yu
5,873,626 A	2/1999	Katz	D720,939 S	1/2015	Toll
D407,910 S	4/1999	Terry	D722,446 S	2/2015	Toll
D408,159 S	4/1999	Clutton	D724,329 S	3/2015	Toll
D409,009 S	5/1999	Toll et al.	D724,330 S	3/2015	Toll
D412,791 S	8/1999	Tsai	D753,925 S	4/2016	Toll
D416,394 S	11/1999	Minkow et al.	D753,926 S	4/2016	Smith et al.
D417,560 S	12/1999	Tollefson et al.	D754,450 S	4/2016	Toll
6,019,423 A	1/2000	Dodge et al.	D756,675 S	5/2016	Toll
6,039,395 A	3/2000	Culbertson	D760,507 S	7/2016	Marcel
D428,270 S	7/2000	Bigolin	D762,073 S	7/2016	Toll
D428,271 S	7/2000	Bigolin	D764,820 S	8/2016	Toll
D429,905 S	8/2000	White	D764,821 S	8/2016	Toll
D430,744 S	9/2000	Minkow et al.	D764,822 S	8/2016	Toll
D430,745 S	9/2000	Minkow et al.	D767,909 S	10/2016	Toll
6,113,184 A	9/2000	Barnes	D767,910 S	10/2016	Toll
6,139,098 A	10/2000	Carrillo	D767,911 S	10/2016	Toll
D433,827 S	11/2000	Kulpers	D769,007 S	10/2016	Toll
D434,235 S	11/2000	Kulpers	D769,008 S	10/2016	Toll
6,193,309 B1	2/2001	Gooter et al.	D769,631 S	10/2016	Toll
D439,756 S	4/2001	Bigolin	D774,790 S	12/2016	Toll
D440,779 S	4/2001	Bernardi	D774,791 S	12/2016	Toll
6,224,151 B1	5/2001	McMullen	D778,079 S	2/2017	Porter et al.
D443,426 S	6/2001	Diaz	D784,033 S	4/2017	Li
6,244,655 B1	6/2001	Minkow et al.	D786,573 S	5/2017	Toll
D446,032 S	8/2001	Arcieri	9,718,509 B2	8/2017	Toll
6,290,291 B1	9/2001	Kojima	D802,947 S	11/2017	Toll
D453,881 S	2/2002	Chuang	D802,948 S	11/2017	Toll
D454,258 S	3/2002	Yates	D802,949 S	11/2017	Toll
D454,259 S *	3/2002	Yates D6/354	D803,594 S	11/2017	Toll
D456,157 S	4/2002	Yates	D804,204 S	12/2017	Bigolin et al.
D456,623 S	5/2002	Yates	D806,415 S	1/2018	Toll
6,402,236 B1	6/2002	Yates	D809,810 S	2/2018	Pizarro
6,422,647 B1	7/2002	Turudich	D846,896 S	4/2019	Hain
6,450,572 B1	9/2002	Kuipers	D846,897 S	4/2019	Toll
D463,676 S	10/2002	Minkow et al.	D846,899 S	4/2019	Toll
6,652,025 B2	11/2003	Sylvester	D846,900 S	4/2019	Toll
6,669,283 B2	12/2003	Yu	D847,522 S	5/2019	Pruitt et al.
6,761,400 B2	7/2004	Hobson	10,358,181 B2	7/2019	Toll
6,783,176 B2	8/2004	Ladson, III	D856,013 S	8/2019	Jalkanen
6,880,885 B2	4/2005	Lan	D856,014 S	8/2019	Jalkanen
D507,421 S	7/2005	Lawson	D875,411 S	2/2020	Bigolin
6,957,857 B1	10/2005	Lee	D879,488 S	3/2020	Liu
7,025,417 B2	4/2006	Cohen	D880,880 S	4/2020	Toll
D523,651 S	6/2006	Chao	D887,731 S	6/2020	Kim
7,077,469 B2	7/2006	Farré	D889,862 S	7/2020	Toll
7,104,600 B2	9/2006	Scholz	10,836,448 B2 *	11/2020	Toll B62J 1/002
7,121,622 B1	10/2006	Mendez	D903,348 S	12/2020	Toll
7,374,517 B2	5/2008	Lockett	D904,049 S *	12/2020	Toll D6/354
D575,070 S	8/2008	Toll	D930,375 S *	9/2021	Jiang D6/354
7,441,836 B2	10/2008	Chen et al.	D980,634 S *	3/2023	Bigolin D6/354
7,478,871 B2	1/2009	Pandozy	D985,950 S *	5/2023	Bigolin D6/354
D590,160 S	4/2009	Hung	D990,180 S *	6/2023	Getter D6/354
7,537,281 B2	5/2009	Riondato	D998,987 S *	9/2023	Ji D6/354
D604,056 S	11/2009	Toll et al.	D999,541 S *	9/2023	Lu D6/354
			2002/0117880 A1	8/2002	Ladson
			2003/0025363 A1	2/2003	Gaggiola
			2003/0034678 A1	2/2003	Farré
			2003/0038515 A1	2/2003	Martin et al.
			2003/0067195 A1	4/2003	Sylvester

(56)

References Cited

U.S. PATENT DOCUMENTS

2003/0071498	A1	4/2003	Yu
2005/0006932	A1	1/2005	Laidlaw
2007/0069557	A1	3/2007	Toll
2007/0102970	A1	5/2007	Wallace
2007/0200399	A1	8/2007	Riondato
2007/0246978	A1	10/2007	Yu
2007/0273184	A1	11/2007	Garneau
2008/0265636	A1	10/2008	Toll
2009/0079237	A1	3/2009	Riondato
2009/0189421	A1	7/2009	Yu et al.
2010/0109392	A1	5/2010	Toll
2011/0298253	A1	12/2011	Toll
2012/0086246	A1	4/2012	Belliveau
2012/0242119	A1	9/2012	Bigolin
2015/0097401	A1	4/2015	Toll
2015/0197171	A1	7/2015	Bigolin
2015/0239515	A1	8/2015	Toll
2017/0355410	A1	12/2017	Yim
2018/0057089	A1	3/2018	Toll
2019/0233042	A1	8/2019	Toll

FOREIGN PATENT DOCUMENTS

FR	796997	4/1936
JP	2007-186075	7/2007
JP	2008-509047	3/2008
JP	2011-143734	7/2011
JP	2012-162255	8/2012
WO	99/14103	3/1999
WO	2006015731	2/2006
WO	2007/038692	4/2007
WO	2014/035972	2/2011
WO	2013/134253	9/2013

OTHER PUBLICATIONS

Randrup et al., "Bicycle Riding as a Cause for Erectile Dysfunction", www.medicalsexuality.org, pp. 26-27, (Nov. 2000).

Jeong et al., "Bicycle Saddle Shape affects penile blood flow", *International Journal of Impotence Research*, 14, 513-517 (2002).

Spears et al., "The Effect of Saddle Design on Stresses in the Perineum during Cycling", *Medical Science Sports Exercise*, vol. 35, No. 9, pp. 1620-1625 (2003).

Bressel et al., "Bicycle Seat Designs and Their Effect on Pelvic Angle, Trunk Angle, and Comfort", *Medical Science Sports Exercise*, vol. 35, No. 2, pp. 327-332 (2003).

Breda et al., and Adara Caruso, M.D., "Development of New Geometric Bicycle Saddle for the Maintenance of Genital—Perineal Vascular Perfusion," *Journal of Sexual Medicine*, vol. 2, Issue 5, pp. 605-611 (Sep. 2005).

Lowe et al., "Effect of Bicycle Saddle Designs on the Pressure to the Perineum of the Bicyclist", *Medical Science Sports Exercise*, vol. 36, No. 6, pp. 1055-1062 (2004).

Bressel et al., "Bicycle Seat Interface Pressure: Reliability, Validity, and Influence of Hand Position and Workload", *Journal of Biomechanics*, vol. 38, Issue 6, pp. 1325-1331 (Jun. 2005).

Bressel et al., "Influence of Bicycle Seat Pressure on compression of the perineum: a MRI Analysis," *Journal of Biomechanics* 40, pp. 198-202 (2007, Accepted Nov. 26, 2005).

U.S. Appl. No. 29/539,809, filed Jul. 21, 2016 with the following characterization: "Noseless Saddles—My Two Cents Worth." *The Bike Noob.*, Jun. 30, 2011 [online], [retrieved on Jul. 8, 2016]. Retrieved from the Internet <URL: <http://bikenooob.com/2011/06/30/noseless-saddles-my-two-cents-worth/>>.

U.S. Appl. No. 29/539,809, filed Jul. 21, 2016 with the following characterization: "Saddles Part 3—ISM Adamo." *Bike Test Reviews.* Apr. 5, 2013 [online], [retrieved on Jul. 8, 2016]. Retrieved from the Internet <URL: <http://biketestreviews.com/saddles-part-3-ism-adamo/>>.

U.S. Appl. No. 29/484,042, filed Jul. 29, 2014 with the following characterization: "Podium Imports ISM Saddles." *Podium Imports.*, Feb. 20, 2013 [online], [retrieved on Jul. 19, 2014]. Retrieved from the Internet <URL: <http://www.podiumimports.ca/shop-online/brand/ism-saddles/>>.

U.S. Appl. No. 29/484,042, filed Jul. 29, 2014 with the following characterization: Alter, Lloyd. "No—Nose Bicycle Seats: Are They The Answer to Erectile Dysfunction And Prostate . . ." *Tree Hugger.*, Sep. 17, 2010 [online], [retrieved on Jul. 19, 2014]. Retrieved from the Internet <URL: <http://www.treehugger.com/bikes/no-nose-bicycle-seats-are-they-the-answer-to-erectile-dysfunction-and-prostate-problems-among-cyclists.html>>.

U.S. Appl. No. 29/484,039, filed Jul. 29, 2014 with the following characterization: Demerly, Tom. "ISM Adamo Time Trial and Racing 2 Saddles: The Triathlon Saddle Evolved . . ." *Just Tri Talk.*, Feb. 27, 2013 [online], [retrieved on Jul. 19, 2014]. Retrieved from the Internet <URL: <http://justtritalk.com/ism-adamo-time-trial-and-racing-2-saddles-the-triathlon-saddle-evolved/>>.

U.S. Appl. No. 29/539,813, filed Jul. 25, 2016 with the following characterization: "Noseless Bicycle Saddles—What You Need To Know." *Electro Heart Beats.*, Mar. 15, 2014 [online], [retrieved on Jul. 8, 2016]. Retrieved from the Internet <URL: <http://www.electroheartbeats.com/2014/03/noseless-bicycle-saddles-what-youneed.html>>.

Patent Cooperation Treaty, "International Search Report and Written Opinion", issued in International Application No. PCT/US2017/048420, by European Searching Authority, document of 15 pages, Nov. 8, 2017.

U.S. Appl. No. 29/635,828, filed Aug. 8, 2019 with the following characterization: Syncros, 2017 Syncros Catalogue: Precision Bicycle Products, p. 008 (Nov. 13, 2016), [online], [site visited Jul. 29, 2019]. Available from internet, <URL: Retrieved from https://issuu.com/rideonscott/docs/2017_catalogue_syncros_en_lo>.

* cited by examiner

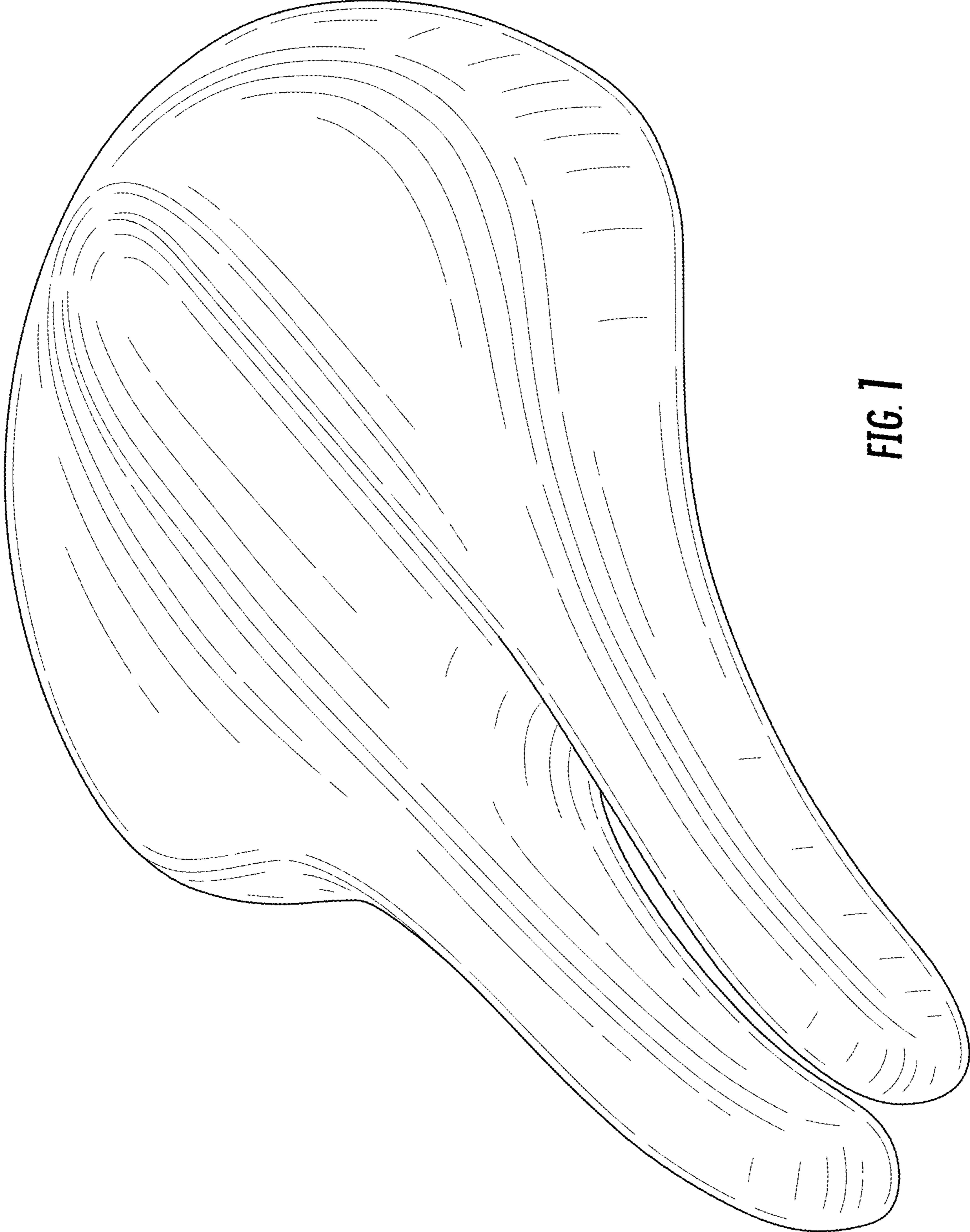

FIG. 1

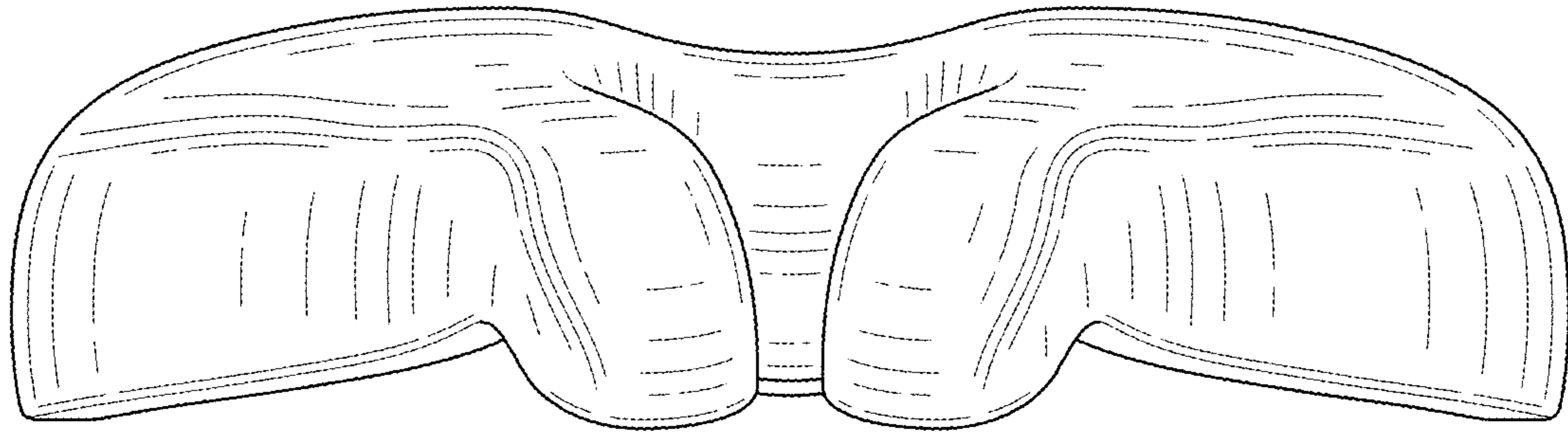

FIG. 2

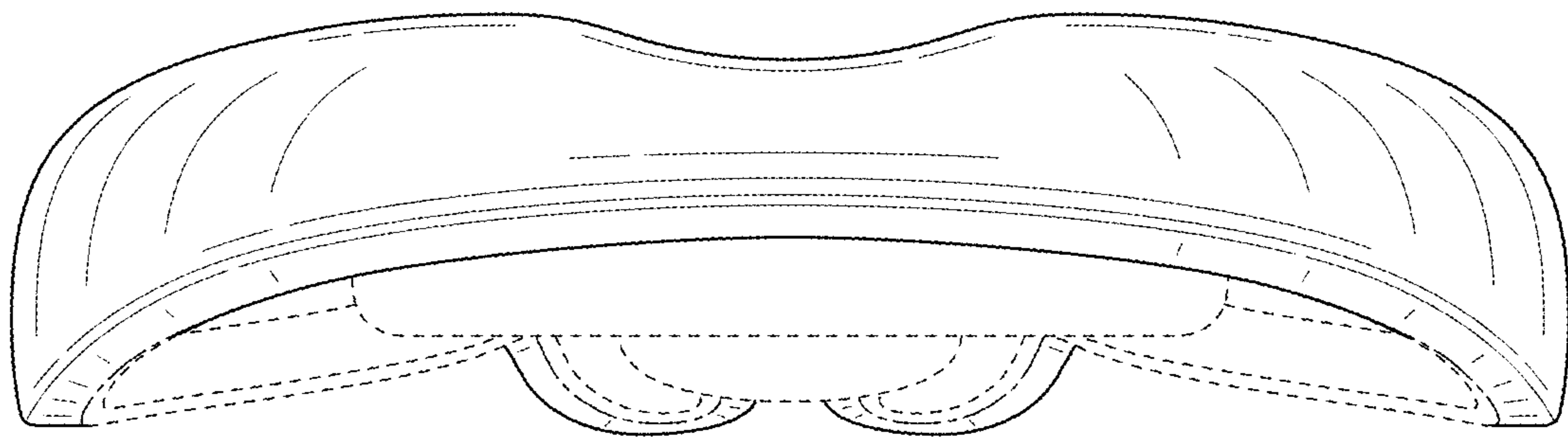

FIG. 3

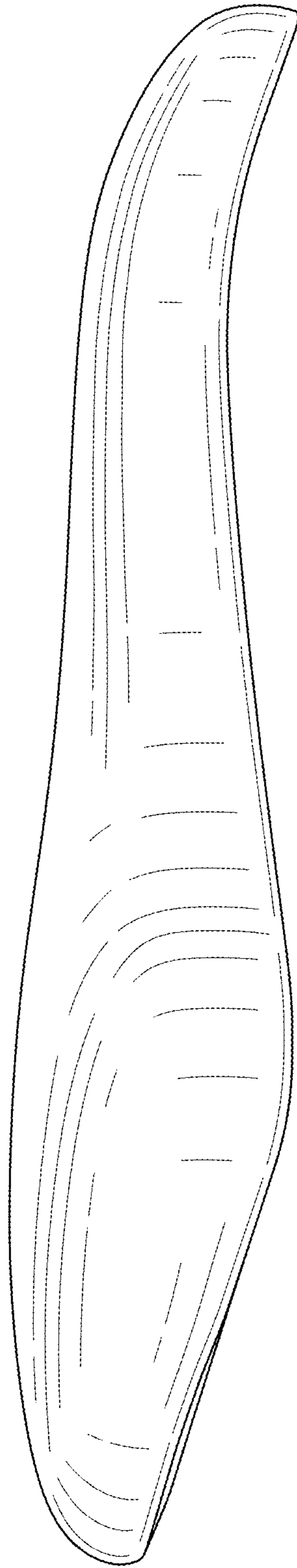

FIG. 4

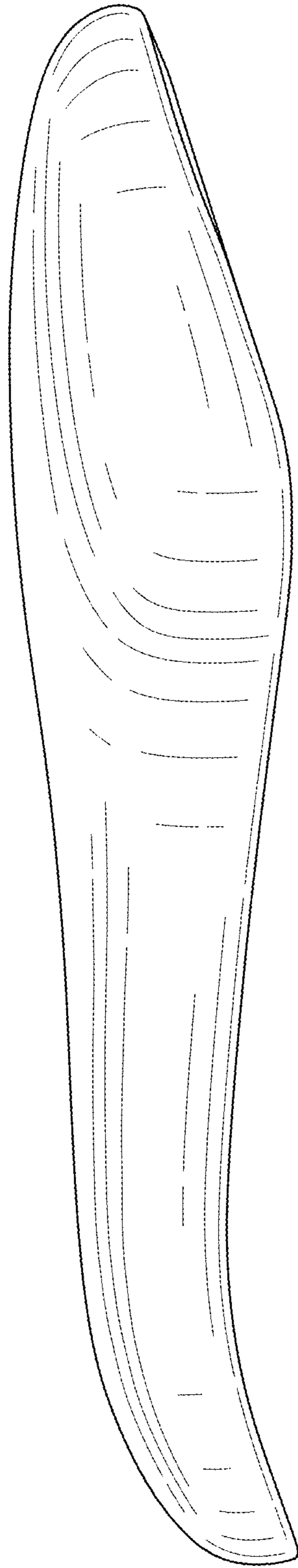

FIG. 5

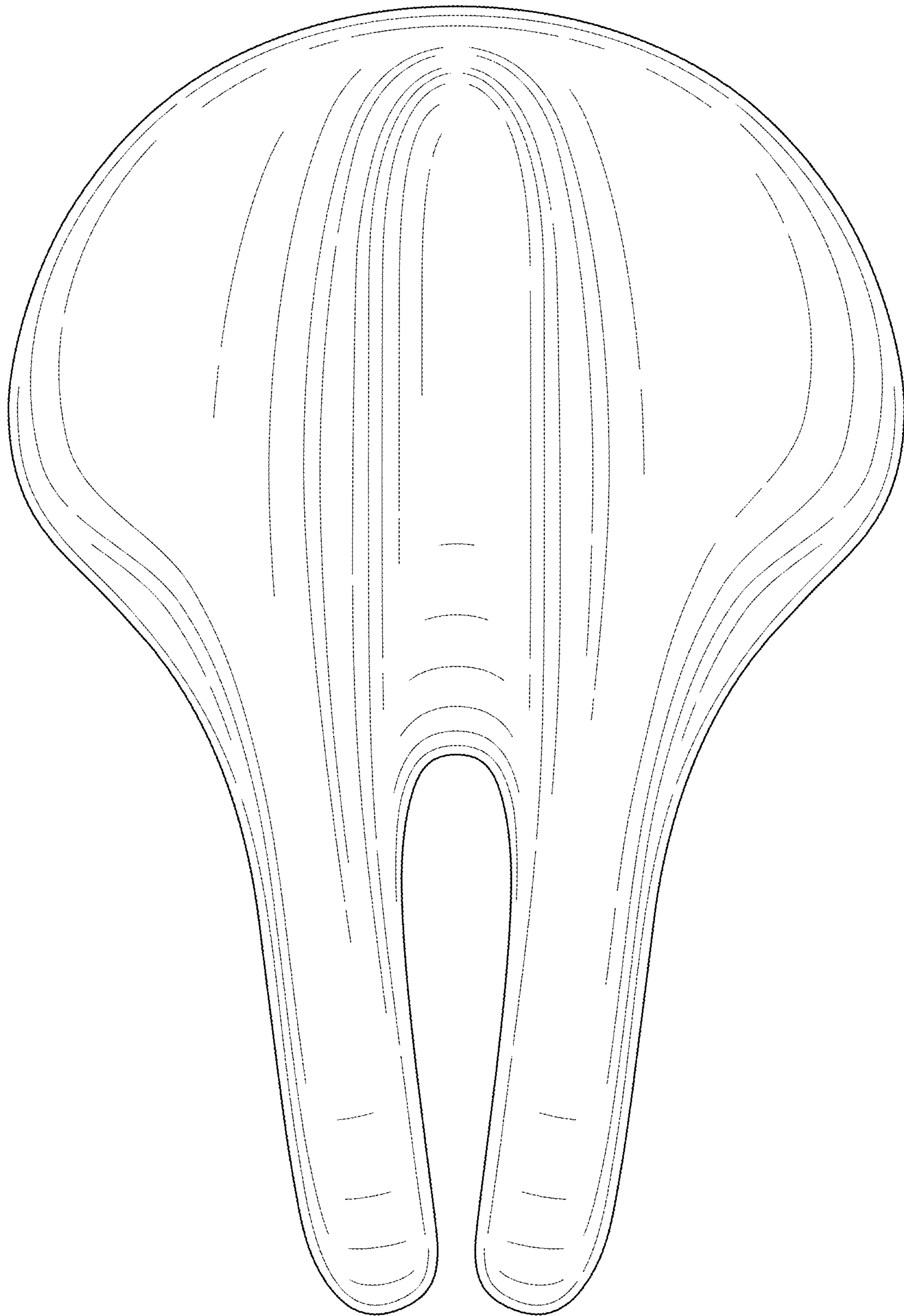

FIG. 6

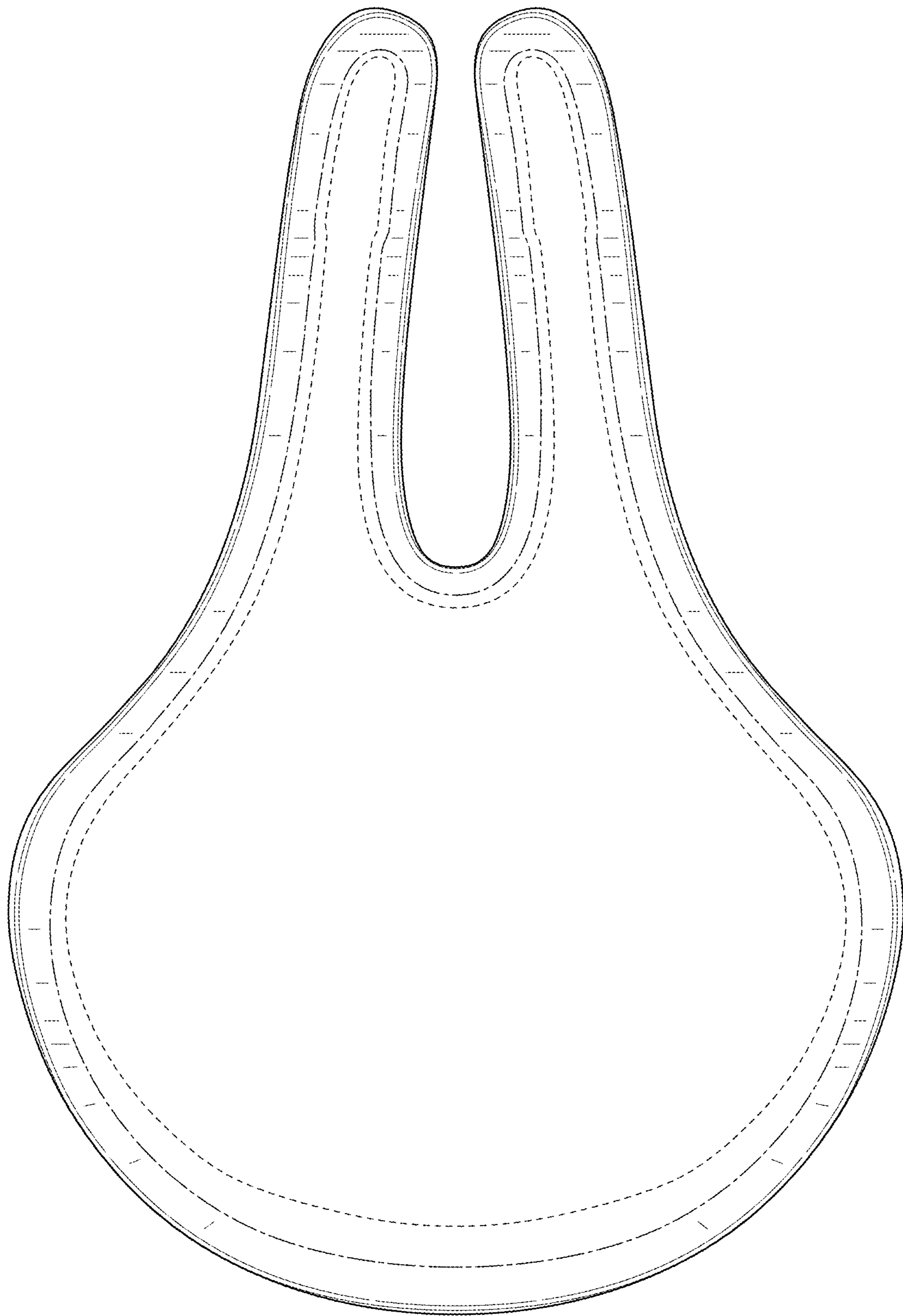

FIG. 7