



US0D1006981S

(12) **United States Design Patent** (10) **Patent No.:** **US D1,006,981 S**
Berney et al. (45) **Date of Patent:** **** Dec. 5, 2023**

(54) **BREATHING CONDUIT**

(71) Applicant: **Fisher & Paykel Healthcare Limited**,
Auckland (NZ)
(72) Inventors: **Liam James Berney**, Auckland (NZ);
Jason Allan Klenner, Auckland (NZ);
Andrew Chi Lup Lau, Auckland (NZ);
Rachel Nicole Mosen, Auckland (NZ);
Emma Louise Nasimi, Auckland (NZ);
David John Sims, Auckland (NZ);
Andrew William White, Auckland
(NZ); **Rachel Helen Barker**, Auckland
(NZ)

(73) Assignee: **Fisher & Paykel Healthcare Limited**,
Auckland (NZ)

(**) Term: **15 Years**

(21) Appl. No.: **29/704,832**

(22) Filed: **Sep. 6, 2019**

(51) **LOC (14) Cl.** **29-02**

(52) **U.S. Cl.**
USPC **D24/110**

(58) **Field of Classification Search**
USPC D24/110, 110.1-110.6, 127, 129;
D29/108, 110

(Continued)

(56) **References Cited**

U.S. PATENT DOCUMENTS

132,604 A 10/1872 Smith et al.
327,877 A 10/1885 Hodges

(Continued)

FOREIGN PATENT DOCUMENTS

CN 101365509 2/2009
CN 101380497 3/2009

(Continued)

OTHER PUBLICATIONS

Huapa Mini hose connector for CPAP hose CPAP accessories
Resmed air nasal masks, Amazon.com, first posted Oct. 9, 2018,
<https://amzn.to/3x62sdy>, 8 pp.

(Continued)

Primary Examiner — Richard Kearney

Assistant Examiner — Michael Hoffman

(74) *Attorney, Agent, or Firm* — Knobbe, Martens, Olson
& Bear LLP

(57) **CLAIM**

The ornamental design for a breathing conduit, as shown and
described.

DESCRIPTION

FIG. 1 is a front perspective view of a breathing conduit
which embodies our design.

FIG. 2 is a rear perspective view thereof.

FIG. 3 is a top view thereof.

FIG. 4 is a bottom view thereof.

FIG. 5 is a left side view thereof

FIG. 6 is a right side view thereof.

FIG. 7 is a rear view thereof; and,

FIG. 8 is a front view thereof.

The broken lines shown in the drawings illustrate portions of
the article and form no part of the claimed design.

The breathing conduit has been shown with break lines in its
length. The appearance of any portion of the article between
the break lines forms no part of the claimed design.

The references to “left,” “right,” “front,” “rear,” “top,” and
“bottom” in the figure descriptions are not meant to require
certain in-use orientation; the breathing conduit according to
the claimed design may be used in any orientation.

1 Claim, 8 Drawing Sheets

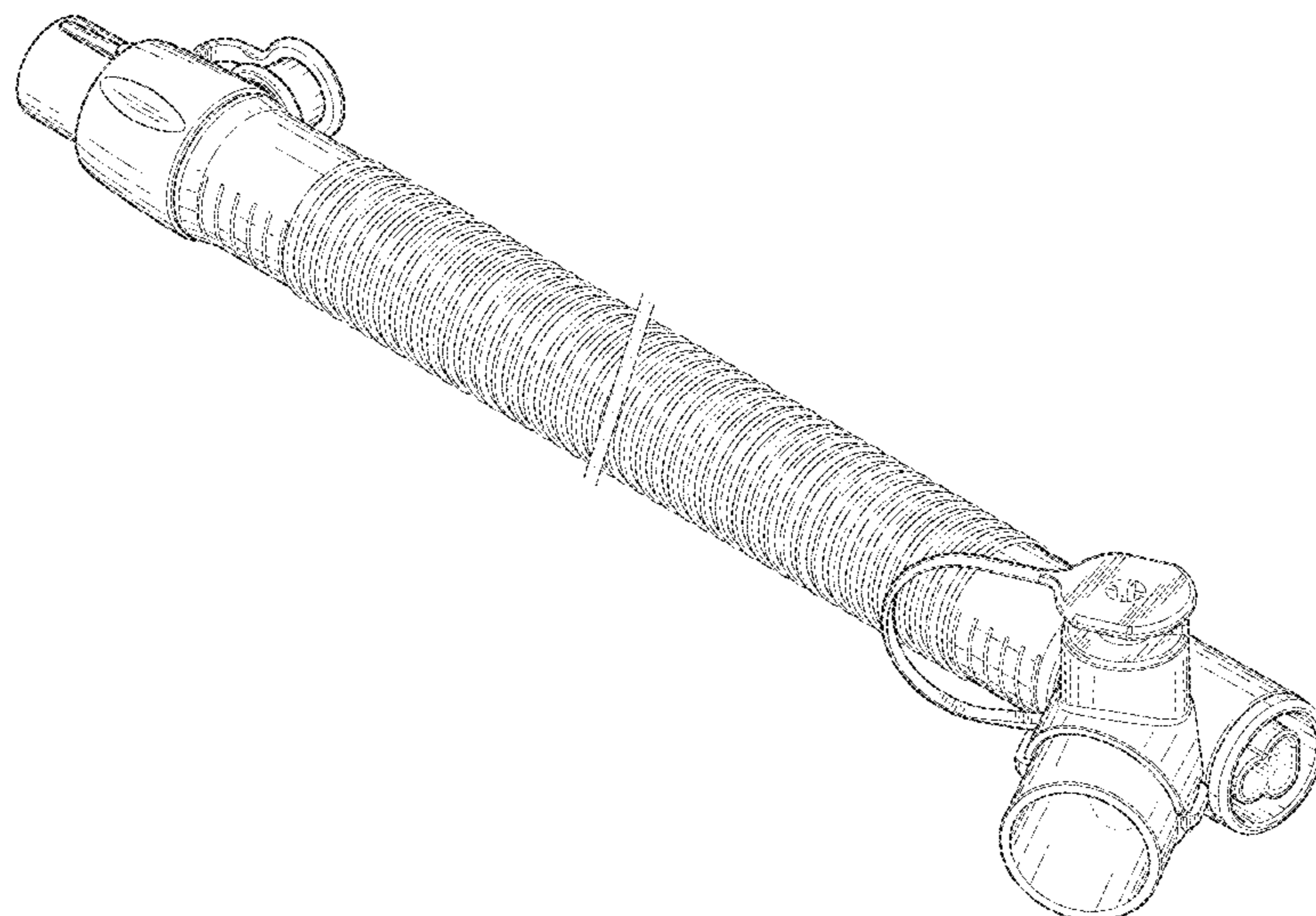

(58) **Field of Classification Search**
 CPC A61M 16/00; A61M 16/0057; A61M
 16/0066; A61M 16/06; A61M 16/0605;
 A61M 16/0616; A61M 16/0622; A61M
 16/0633; A61M 16/0644; A61M 16/0666;
 A61M 16/0683; A61M 16/0688; A61M
 16/08; A61M 16/0816; A61M 16/0825;
 A61M 16/0875; A61M 35/10; B63C
 11/12; B63C 11/16; B63C 11/186; B63C
 11/205

See application file for complete search history.

(56) **References Cited**

U.S. PATENT DOCUMENTS

1,880,098 A 9/1932 Mair
 2,124,474 A 7/1938 Scholtes
 2,479,580 A 8/1949 Marco
 3,513,844 A 5/1970 Smith
 3,815,754 A 6/1974 Rosenberg
 4,036,616 A 7/1977 Byrns
 4,111,514 A 9/1978 Brishka et al.
 4,128,407 A 12/1978 Chapel
 D267,199 S 12/1982 Koenig
 4,443,028 A 4/1984 Hayes
 4,446,869 A 5/1984 Knodle
 4,584,997 A 4/1986 Delong
 4,589,684 A 5/1986 Nowacki et al.
 4,601,495 A 7/1986 Webb
 4,661,110 A 4/1987 Fortier et al.
 4,676,241 A 6/1987 Webb et al.
 4,773,448 A 9/1988 Francis
 D300,271 S 3/1989 Rudolph et al.
 D300,272 S 3/1989 Rudolph et al.
 D302,040 S * 7/1989 Lambert D23/314
 5,040,527 A 8/1991 Larson et al.
 5,064,226 A 11/1991 Klas
 D328,033 S 7/1992 DiGuseppi
 5,158,569 A 10/1992 Strickland et al.
 5,335,656 A 8/1994 Bowe et al.
 D362,718 S 9/1995 Deily et al.
 D363,541 S 10/1995 Cottone, Sr. et al.
 5,529,284 A 6/1996 Berger et al.
 5,584,997 A 12/1996 Yagihashi et al.
 5,725,258 A 3/1998 Kujawski
 5,735,271 A 4/1998 Lorenzen et al.
 D395,502 S 6/1998 Deily et al.
 5,901,705 A 5/1999 Leagre
 D424,687 S 5/2000 Hoenig et al.
 6,099,519 A 8/2000 Olsen
 D431,634 S 10/2000 Mantz
 D439,326 S * 3/2001 Hecker D24/110.5
 D449,107 S 10/2001 Madsen
 6,439,234 B1 8/2002 Curti et al.
 6,484,724 B1 11/2002 Sloan
 D468,015 S 12/2002 Horppu
 D472,316 S 3/2003 Douglas et al.
 D472,630 S 4/2003 Douglas et al.
 6,561,549 B1 5/2003 Moris et al.
 6,581,974 B1 6/2003 Ragner et al.
 6,893,055 B2 5/2005 Thomas et al.
 6,915,705 B1 7/2005 Truitt
 6,932,390 B1 8/2005 Gretz
 6,953,354 B2 10/2005 Edirisuriya
 7,007,694 B2 3/2006 Aylsworth et al.
 D522,360 S 6/2006 Caserta
 7,201,167 B2 4/2007 Fink et al.
 D543,620 S 5/2007 Chu et al.
 D547,657 S 7/2007 Tacchella
 D551,340 S 9/2007 Wood et al.
 7,263,994 B2 9/2007 Gradon et al.
 7,267,121 B2 9/2007 Ivri
 D553,005 S 10/2007 Py
 7,290,541 B2 11/2007 Ivri et al.
 D556,899 S 12/2007 Veliss et al.
 7,306,121 B2 12/2007 Ophardt

7,311,752 B2 12/2007 Tepper
 D570,457 S 6/2008 Brown
 7,406,966 B2 8/2008 Wondka
 7,458,615 B2 12/2008 White et al.
 D586,911 S 2/2009 McAuley et al.
 D600,343 S 9/2009 Degabriele et al.
 D606,494 S 12/2009 Holliday
 D612,481 S 3/2010 Reid et al.
 7,785,300 B2 8/2010 Ishii et al.
 D627,059 S 11/2010 Wood et al.
 D631,542 S 1/2011 DeGross
 D637,713 S 5/2011 Nord et al.
 7,946,291 B2 5/2011 Fink et al.
 D645,547 S 9/2011 Lombardi et al.
 8,020,551 B2 9/2011 Virr et al.
 D654,573 S 2/2012 Lombardi et al.
 D656,231 S * 3/2012 Henry D24/110.4
 D661,785 S 6/2012 Johnson
 8,317,203 B2 11/2012 Hermle et al.
 D672,037 S 12/2012 Miller
 8,376,412 B2 2/2013 Johnson
 8,397,727 B2 3/2013 Ng et al.
 D682,415 S 5/2013 Mogensen et al.
 8,439,039 B2 5/2013 Gunaratnam et al.
 D685,463 S 7/2013 Veliss et al.
 8,485,193 B2 7/2013 Worley
 8,534,278 B2 9/2013 Colman et al.
 D691,712 S * 10/2013 Judson D24/110.1
 D691,717 S 10/2013 McLean et al.
 D692,555 S 10/2013 Maksym
 D695,890 S 12/2013 Bowden et al.
 D697,200 S 1/2014 Mahaffy
 D698,440 S 1/2014 Lombardi, III
 8,622,057 B2 1/2014 Ujhazy et al.
 D707,355 S 6/2014 Bow
 8,741,220 B2 6/2014 O'Donnell et al.
 D710,695 S 8/2014 Pritikin
 8,814,849 B1 8/2014 Winsor
 D717,942 S 11/2014 Neff et al.
 D724,720 S 3/2015 O'Connor et al.
 8,967,144 B2 3/2015 Lurie
 D726,287 S 4/2015 Steele
 D727,492 S 4/2015 Scampoli
 D735,038 S 7/2015 Tamarindo
 D735,326 S 7/2015 Gulliver
 D736,906 S 8/2015 Schultz
 D737,963 S 9/2015 Srinivasan et al.
 9,188,267 B2 11/2015 Fansler et al.
 D746,416 S 12/2015 Bariar
 D747,471 S 1/2016 Gulliver et al.
 D747,794 S 1/2016 Greenberg et al.
 D750,239 S 2/2016 Pappalardo
 D757,259 S 5/2016 Duck
 D757,933 S 5/2016 Lev et al.
 D759,486 S 6/2016 Ingram
 D764,049 S 8/2016 Cullen et al.
 D768,285 S 10/2016 Reed
 D771,247 S 11/2016 Shinohara et al.
 D777,317 S 1/2017 Soual et al.
 D777,324 S 1/2017 Nguyen
 D781,417 S 3/2017 Ingram
 D784,525 S 4/2017 Nguyen
 D785,161 S 4/2017 Dravitzki et al.
 D785,789 S 5/2017 Turturro et al.
 D787,053 S 5/2017 Huang et al.
 D787,054 S 5/2017 Rini et al.
 D787,661 S * 5/2017 Edwards D24/110.4
 D790,054 S 6/2017 Prentice et al.
 9,669,181 B2 6/2017 Miller et al.
 9,675,774 B2 6/2017 Cipollone
 D791,310 S 7/2017 Maurice
 D791,938 S 7/2017 Becker
 D791,939 S 7/2017 Turturro et al.
 D794,184 S 8/2017 Smith et al.
 D794,781 S 8/2017 Gilbert et al.
 D800,895 S 10/2017 Prentice
 D804,023 S 11/2017 Huang et al.
 9,808,612 B2 11/2017 Gulliver et al.
 D804,661 S 12/2017 Shoji et al.

(56)

References Cited

U.S. PATENT DOCUMENTS

D805,629 S	12/2017	Fiorenza		2002/0112730 A1	8/2002	Dutkiewicz
D807,995 S *	1/2018	Maeckelberghe D24/164	2002/0173748 A1	11/2002	McConnell
9,868,001 B2	1/2018	Walker et al.		2004/0090066 A1	5/2004	Hoffmann
9,879,807 B2	1/2018	Brugger et al.		2004/0103686 A1	6/2004	Fehr et al.
D809,656 S	2/2018	Lau et al.		2004/0108218 A1	6/2004	Stubergh
9,884,176 B2	2/2018	Fangrow		2004/0261797 A1	12/2004	White et al.
D816,216 S	4/2018	Gulliver et al.		2005/0011524 A1	1/2005	Thomlinson et al.
D825,749 S	8/2018	Huang et al.		2005/0028822 A1	2/2005	Sleeper et al.
D827,125 S	8/2018	Nilsson		2005/0077726 A1	4/2005	White et al.
D827,126 S	8/2018	Nilsson et al.		2005/0283114 A1	12/2005	Bresina
D832,431 S	10/2018	Turturro		2006/0107958 A1	5/2006	Sleeper
D834,533 S	11/2018	Maroney		2006/0107960 A1	5/2006	Smart
D834,712 S	11/2018	Gulliver et al.		2006/0113690 A1	6/2006	Huddart
D835,260 S	12/2018	Lisberg		2007/0043334 A1	2/2007	Guala
D837,743 S	1/2019	Maroney		2007/0088327 A1	4/2007	Guala
D841,147 S *	2/2019	McCool D24/110	2007/0163588 A1	7/2007	Hebrank et al.
D841,148 S	2/2019	Stoks et al.		2007/0169825 A1	7/2007	Packham et al.
10,245,407 B2	4/2019	Osborne		2007/0175473 A1	8/2007	Lewis et al.
10,265,492 B2	4/2019	Amarasinghe et al.		2008/0041391 A1	2/2008	Worley
D849,242 S	5/2019	Wilson		2008/0093846 A1	4/2008	Sparks et al.
D849,931 S	5/2019	Prentice		2008/0105257 A1	5/2008	Klasek
10,322,254 B2	6/2019	Fong et al.		2008/0142019 A1	6/2008	Lewis et al.
D852,949 S	7/2019	Klenner et al.		2008/0183153 A1	7/2008	Enns
10,335,583 B2	7/2019	Gulliver et al.		2008/0190436 A1	8/2008	Jaffe et al.
D855,794 S	8/2019	Gray		2008/0264413 A1	10/2008	Doherty et al.
D856,510 S	8/2019	Scheirlinck		2008/0287920 A1	11/2008	Fangrow et al.
D857,880 S	8/2019	Lau et al.		2009/0101147 A1	4/2009	Landis et al.
D860,445 S	9/2019	Ho		2009/0120434 A1	5/2009	Smith et al.
D861,162 S	9/2019	Gulliver et al.		2009/0223523 A1	9/2009	Chang
D863,545 S	10/2019	Dantanarayana		2009/0223963 A1	9/2009	Bisio
D867,583 S	11/2019	Yang et al.		2009/0266357 A1	10/2009	Varis et al.
D867,586 S	11/2019	Kemps et al.		2009/0299158 A1	12/2009	Boatner et al.
D867,587 S	11/2019	Holtz et al.		2010/0043789 A1	2/2010	Fine et al.
D870,878 S	12/2019	Wilson		2010/0116272 A1	5/2010	Row et al.
D876,617 S	2/2020	Scheirlinck et al.		2010/0163051 A1	7/2010	Brewer et al.
D878,546 S *	3/2020	Formica D24/110	2010/0168600 A1	7/2010	Adriance et al.
D878,549 S	3/2020	Wilson		2010/0192957 A1	8/2010	Hobson et al.
D879,953 S	3/2020	Ljunglof et al.		2010/0206310 A1	8/2010	Matsubara et al.
D879,956 S	3/2020	Klenner et al.		2010/0242961 A1	9/2010	Mougel et al.
D880,686 S *	4/2020	Stoks D24/110	2011/0067704 A1	3/2011	Kooij et al.
D887,577 S	6/2020	Shor et al.		2011/0139826 A1	6/2011	Hair
D893,024 S	7/2020	Whiteside		2011/0162644 A1	7/2011	Ujhazy et al.
D893,016 S	8/2020	Wilson		2011/0240031 A1	10/2011	Jaffre
D895,103 S	9/2020	Dantanarayana		2011/0253136 A1	10/2011	Sweeney et al.
D896,758 S	9/2020	Watkins et al.		2011/0265796 A1	11/2011	Amarasinghe et al.
D896,929 S	9/2020	Vranish		2013/0037030 A1	2/2013	Matula
10,786,663 B2	9/2020	Lauer		2013/0104888 A1	5/2013	Landis et al.
D899,590 S	10/2020	Gulliver et al.		2013/0133651 A1	5/2013	Barker et al.
10,792,486 B2	10/2020	Nelson		2013/0167841 A1	7/2013	Sheffer et al.
D903,121 S	11/2020	Chan		2013/0255670 A1	10/2013	Ott et al.
10,835,733 B1	11/2020	Gulliver et al.		2013/0264821 A1	10/2013	Duck
D909,564 S	2/2021	Bogan		2013/0284167 A1	10/2013	Porteous et al.
D910,840 S	2/2021	Klenner et al.		2014/0000626 A1	1/2014	O'Connor et al.
D917,690 S	4/2021	Lau et al.		2014/0014108 A1	1/2014	Dillard
D923,169 S *	6/2021	McCool D24/110	2014/0053846 A1	2/2014	Wood
D923,768 S *	6/2021	Maeckelberghe D23/358	2014/0144438 A1	5/2014	Klasek
D924,154 S	7/2021	Dykas et al.		2014/0191501 A1	7/2014	Brugger et al.
D924,377 S	7/2021	Kwak et al.		2014/0200475 A1	7/2014	Rubin
D925,734 S	7/2021	Park		2014/0238401 A1	8/2014	Paschall
D928,925 S	8/2021	Lei		2014/0261416 A1	9/2014	Arcilla et al.
D928,948 S	8/2021	Gulliver et al.		2014/0338669 A1	11/2014	Zhao et al.
D928,949 S	8/2021	Gulliver et al.		2014/0373841 A1	12/2014	Nashed
D930,184 S	9/2021	Johnson		2015/0021909 A1	1/2015	Gulliver et al.
D933,815 S *	10/2021	Eves D24/110.4	2015/0059745 A1	3/2015	Barker et al.
D938,016 S *	12/2021	Eves D24/110.4	2015/0083121 A1	3/2015	Fisher
D940,861 S	1/2022	Mosen et al.		2015/0128944 A1	3/2015	Fisher
11,224,728 B2	1/2022	Lgnon		2015/0167877 A1	5/2015	Buechi
D944,936 S	3/2022	Chaves et al.		2015/0290416 A1	6/2015	Carefusion
D944,939 S	3/2022	Chaves		2015/0306332 A1	10/2015	Klasek
D948,027 S	4/2022	Babbage et al.		2015/0320949 A1	10/2015	Bafle et al.
D949,294 S	4/2022	Chandler		2015/0320962 A1	11/2015	Jaffe
D949,295 S	4/2022	Chaves		2016/0001031 A1	11/2015	Bafle et al.
2001/0004970 A1	6/2001	Hollister		2016/0082218 A1	1/2016	Laing et al.
2001/0029949 A1	10/2001	Blackhurst et al.		2016/0106913 A1	3/2016	Lau
2002/0017302 A1	2/2002	Fukunaga et al.		2016/0131292 A1	4/2016	Ng et al.
				2016/0193440 A1	5/2016	Decker
				2016/0228668 A1	7/2016	Sheffer et al.
				2016/0287824 A1	8/2016	Martin
				2016/0305574 A1	10/2016	Chang
					10/2016	Burdge

(56)

References Cited

U.S. PATENT DOCUMENTS

2017/0036007 A1 2/2017 Hallisey et al.
 2017/0065788 A1 3/2017 Chou
 2017/0065789 A1 3/2017 Reed
 2017/0197055 A1 7/2017 Moody
 2017/0361051 A1 12/2017 Eifler
 2018/0064901 A1 3/2018 Colman
 2018/0078728 A1 3/2018 Holyoake et al.
 2018/0085544 A1 3/2018 Holyoake
 2018/0117270 A1 5/2018 Bassin
 2018/0140819 A1 5/2018 Yang
 2018/0200148 A1 7/2018 Sanders
 2019/0022344 A1 1/2019 Lau et al.
 2019/0321617 A1 5/2019 Gulliver et al.
 2019/0167935 A1 6/2019 Siew et al.
 2019/0381268 A1 12/2019 Colman
 2020/0129724 A1 4/2020 Nelson
 2020/0345997 A1 11/2020 Gulliver et al.
 2021/0322706 A1 10/2021 Lau et al.
 2021/0361924 A1 11/2021 Gulliver et al.
 2021/0402126 A1 12/2021 Lau et al.
 2021/0402127 A1 12/2021 Lau et al.

FOREIGN PATENT DOCUMENTS

CN 201775849 3/2011
 CN 102019014 4/2011
 CN 103180650 6/2013
 CN 103764213 4/2014
 CN 103857432 6/2014
 CN 104853796 8/2015
 CN 104870042 8/2015
 DE 37 09 122 A1 9/1988
 DE 10 2007 063 556 A1 7/2009
 EM 008110019-0001 9/2020
 EP 1 068 889 1/2001
 EP 1181945 A1 2/2002
 EP 0809768 B1 7/2002
 EP 1 314 446 8/2002
 EP 1 277 488 1/2003
 EP 1 403 838 3/2004
 EP 1408313 A2 4/2004
 EP 1520599 A1 10/2004
 EP 1479405 A1 11/2004
 EP 1 481 702 12/2004
 EP 1 023 912 B1 11/2005
 EP 1 449 502 12/2007
 EP 1933074 6/2018
 EP 3344319 7/2018
 EP 2 925 396 9/2020
 GB 2328260 2/1999
 JP 09-028806 2/1997
 JP 2007-236567 9/2007
 JP 2010-527276 8/2010
 JP 2014-516601 7/2014
 JP 2014-521471 8/2014
 JP D1639030 8/2019
 KR 1020040103139 12/2004
 WO WO 90/014122 11/1990
 WO WO 94/004211 3/1994
 WO WO 97/015376 5/1997
 WO WO 99/012598 3/1999
 WO WO 2003/082406 10/2003
 WO WO 2004/108218 12/2004
 WO WO 05/018524 3/2005
 WO WO 2005/079670 9/2005
 WO WO 05/102431 11/2005
 WO WO 07/019625 2/2007
 WO WO 07/024812 3/2007
 WO WO 2008/144447 A2 11/2008
 WO WO 09/094532 7/2009
 WO WO 09/146484 12/2009
 WO WO 11/062510 5/2011
 WO WO 2011/079226 A1 6/2011
 WO WO 12/052903 4/2012
 WO WO 2013/022356 2/2013

WO WO 13/088439 6/2013
 WO WO 13/127474 9/2013
 WO WO 14/015382 1/2014
 WO WO 14/077706 5/2014
 WO WO 2014/097145 6/2014
 WO WO 2014/129912 8/2014
 WO WO 15/038014 3/2015
 WO WO 16/157101 10/2016

OTHER PUBLICATIONS

Pall Corporation, Jun. 10, 2019, Multiple-Patient-Use Anesthesia Circuits, product description, 5 pp.
 Salter Labs, "Air-Q Intubating Laryngeal Airways (ILA) The everyday airway that's ready for the unexpected."; Dec. 2018; 8 pages.
 Chinese Patent Office, Examination Report, Application No. CN 201680060677.1, dated Nov. 16, 2020, in 14 pages.
 Fisher & Paykel Healthcare Limited, Junior Tube and Chamber Kit brochure, 900PT531, 2012.
 Photos of current commercial connector illustrated in Reference 1 in 3 pages.
 International Search Report, PCT/IB2016/055258, dated Nov. 14, 2016, in 4 pages.
 PCT Application No. PCT/NZ2012/000142 International Search Report and Written Opinion dated Jan. 22, 2013, in 14 pages.
 PCT Application No. PCT/NZ2012/000142 International Preliminary Report on Patentability dated Feb. 14, 2014 in 6 pages.
 Office Action in corresponding Japanese Patent Application No. 2014-524961, dated Nov. 8, 2017, in 2 pages.
 Office Action in corresponding Taiwanese Patent Application No. 1061015308, dated Apr. 12, 2007, in 4 pages.
 Search Report in corresponding Taiwanese Patent Application No. 1061015308, dated Apr. 12, 2007, in 1 page.
 Combined Search and Examination Report in corresponding United Kingdom Patent Application No. GB 10800268.3, dated Jan. 25, 2018, in 6 pages.
 Examination Report in corresponding United Kingdom Patent Application No. GB 10800268.3, dated Jun. 8, 2018, in 3 pages.
 Extended Search Report in corresponding European Patent Application No. 17195173.4, dated May 22, 2018, in 13 pages.
 Office Action in corresponding Canadian Patent Application No. 2844802, dated Jun. 6, 2018, in 4 pages.
 Office Action in corresponding United Kingdom Patent Application No. 1807231.4, dated Jun. 19, 2018, in 9 pages.
 Examination Report in corresponding United Kingdom Patent Application No. 1800268.3, dated Jul. 3, 2018, in 2 pages.
 Examination Report in corresponding United Kingdom Patent Application No. 1807231.4, dated Aug. 31, 2018, in 2 pages.
 Examination Report in corresponding Australian Patent Application No. 2017202180, dated Aug. 31, 2018, in 3 pages.
 Examination Report in corresponding Taiwanese Patent Application No. 106105308, dated Aug. 10, 2018, in 6 pages.
 Examination Report in corresponding United Kingdom Patent Application No. 1810896.9, dated Nov. 20, 2018, in 5 pages.
 Supplementary European Search Report, European Patent Office, Application No. EP 16 84 0949, dated Jan. 17, 2019, in 3 pages.
 Examination Report in corresponding Chinese Patent Application No. 201710181760.0, dated May 29, 2019, in 5 pages.
 Examination Report in corresponding Chinese Patent Application No. 201710181804.X, dated May 29, 2019, in 8 pages.
 Office Action in corresponding Canadian Patent Application No. 2,844,802, dated Jun. 12, 2019, in 4 pages.
 Office Action in corresponding Japanese Patent Application No. 2018-041463, dated Jan. 31, 2019, in 2 pages.
 Office Action in corresponding Australian Patent Application No. 2017202180, dated Jul. 19, 2019, in 3 pages.
 Decision for Final Rejection in corresponding Japanese Patent Application No. 2018-041463, Aug. 1, 2019, in 2 pages.
 Examination Report for GB1803152.6, dated May 26, 2020, 2 pages.
 GB Intellectual Property Office, Examination Report under Section 18(3), Application No. GB1803152.6, dated Oct. 26, 2020, in 2 pages.

(56)

References Cited

OTHER PUBLICATIONS

Chinese Patent Office, Notification Letter of Review Opinion, Taiwan Design Application No. 109304590, dated Jan. 6, 2021 in 4 pages.

Japanese Patent Office, Notice of Reasons of Refusal, Official Action, Japanese Application No. 2019-2233563, dated Feb. 25, 2021, in 9 pages.

European Patent Office, Examination Report, Application No. 16840949.8, dated Feb. 16, 2021 in 4 pages.

Examination Report for JP2018-512159, dated Aug. 20, 2020, 15 pages total with machine translation.

JML Medical, Adaptor One Way Valve 220Dx221D w/Oxygen Stem, Teleflex, [Post date unknown], downloaded May 19, 2022, <https://www.jmlmed.com/collections/respiratory-products/products/one-way-valve-by-teleflex>, 2 pp.

New Leaf Home Medical, Pressure Line Adaptor for Ventilation Accessories, Medline, [Post date Unknown], downloaded May 19, 2022 <https://newleafhomemedical.com/pressure-line-adaptor-for-ventilation-accessories/>, 1 p.

RC Medical Incorporated, Hudson Dual Spray MDI Adaptor, CS/50, [Post date: Post date unknown], downloaded, May 19, 2022, <https://www.rcmedical.com/viewProduct.cfm?productID=871>, 1 p.

* cited by examiner

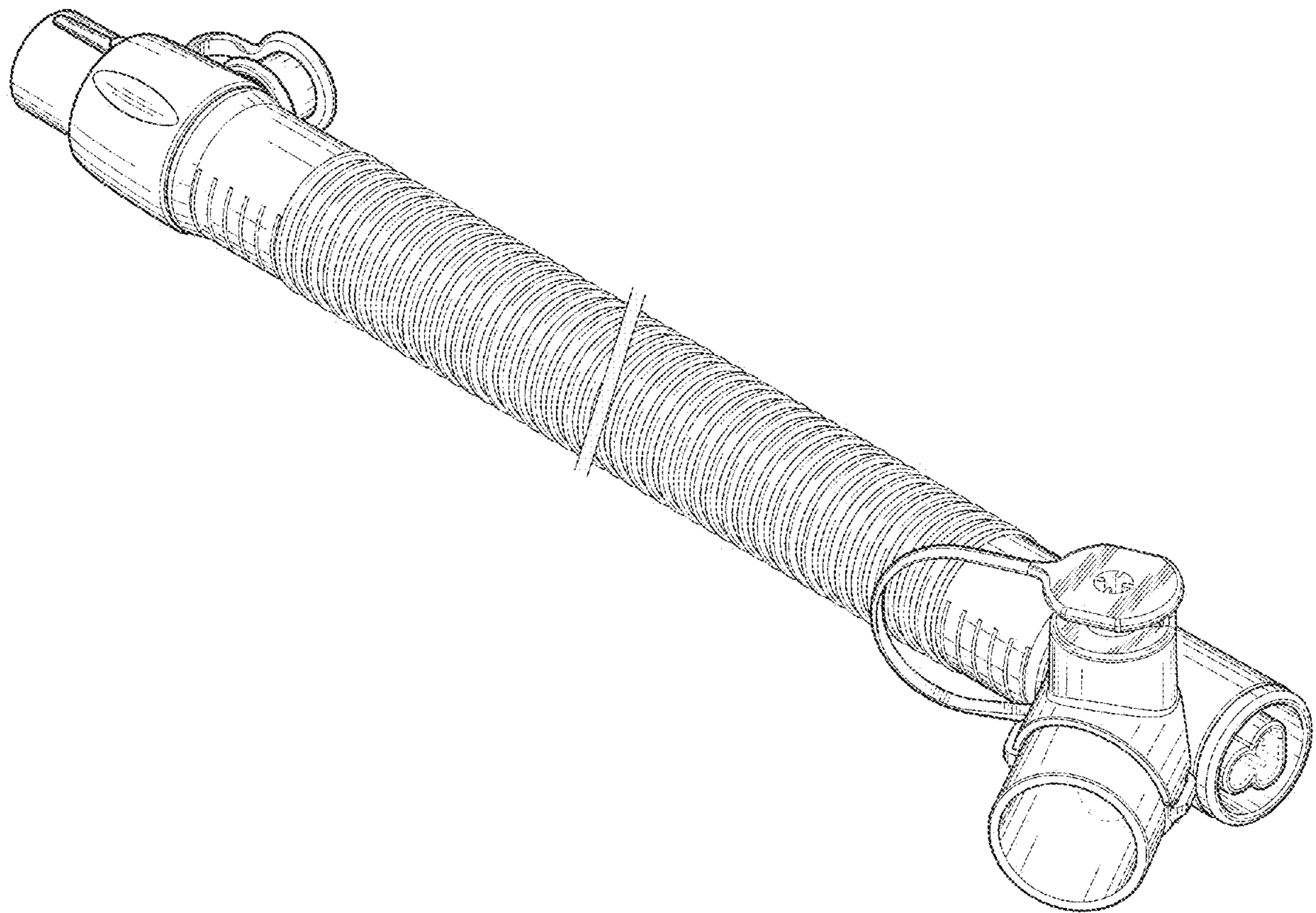

FIG. 1

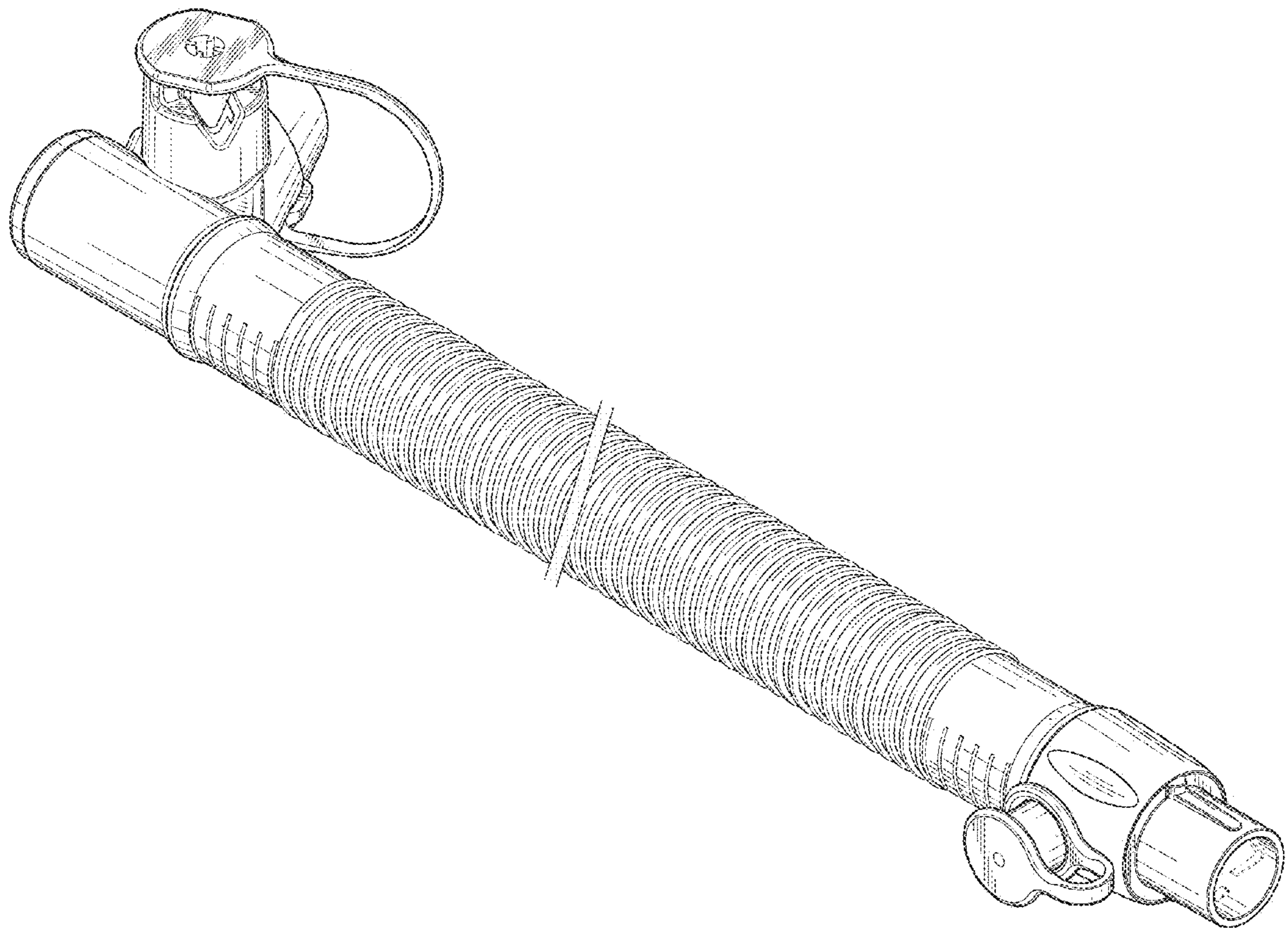
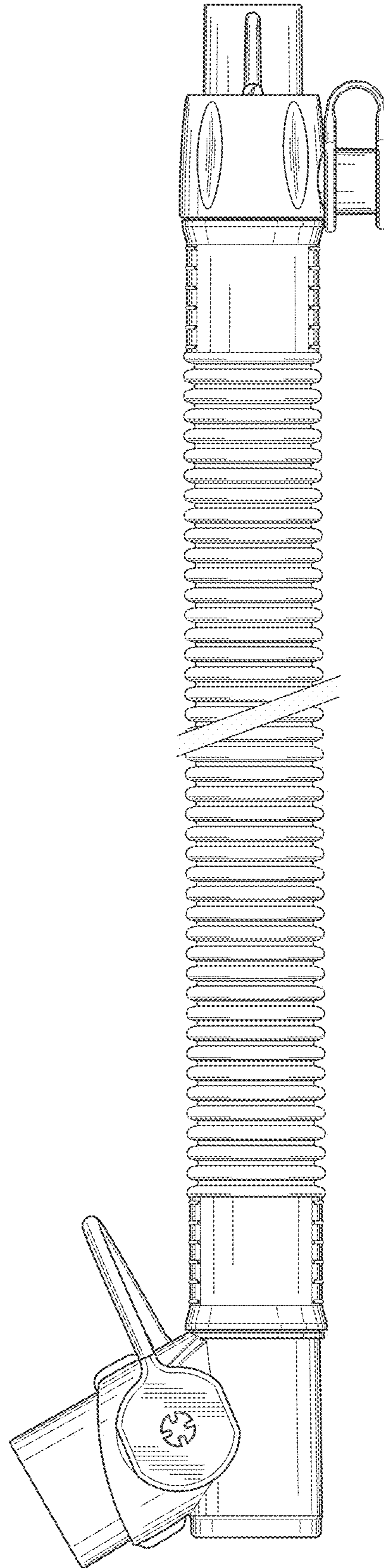

FIG. 2

FIG. 3



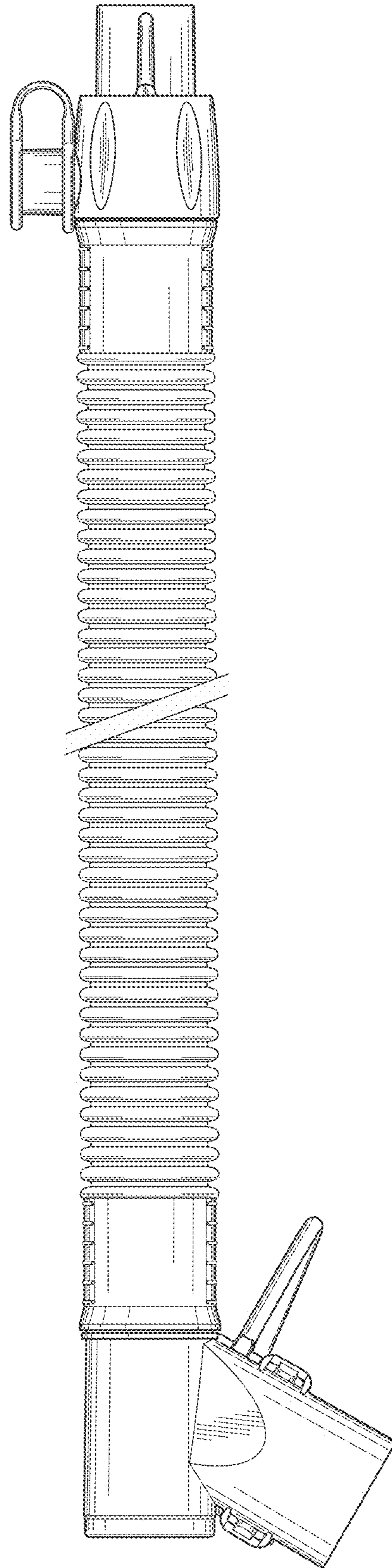
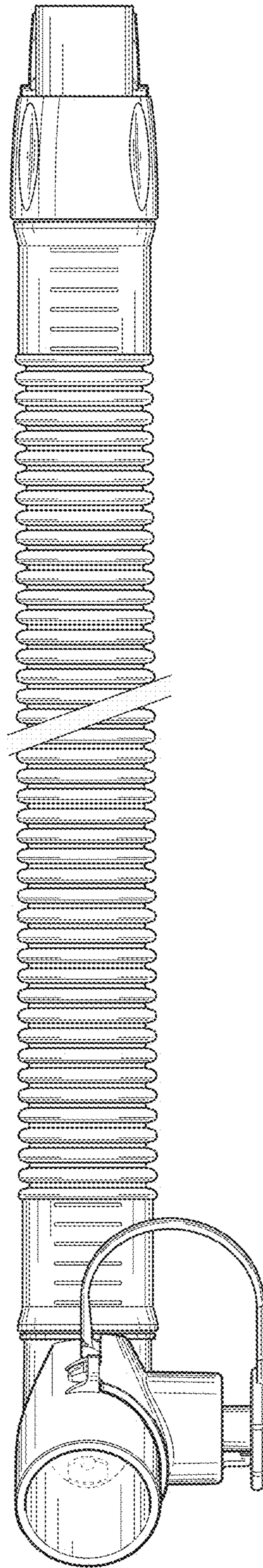

FIG. 4

FIG. 5



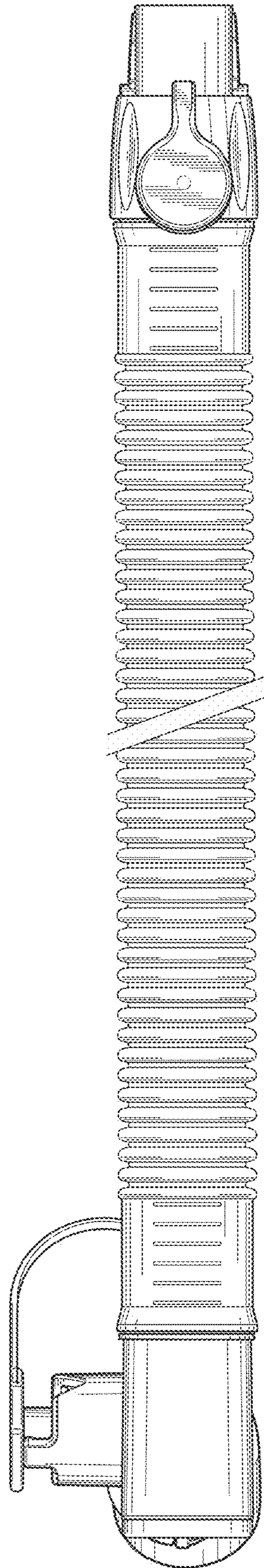

FIG. 6

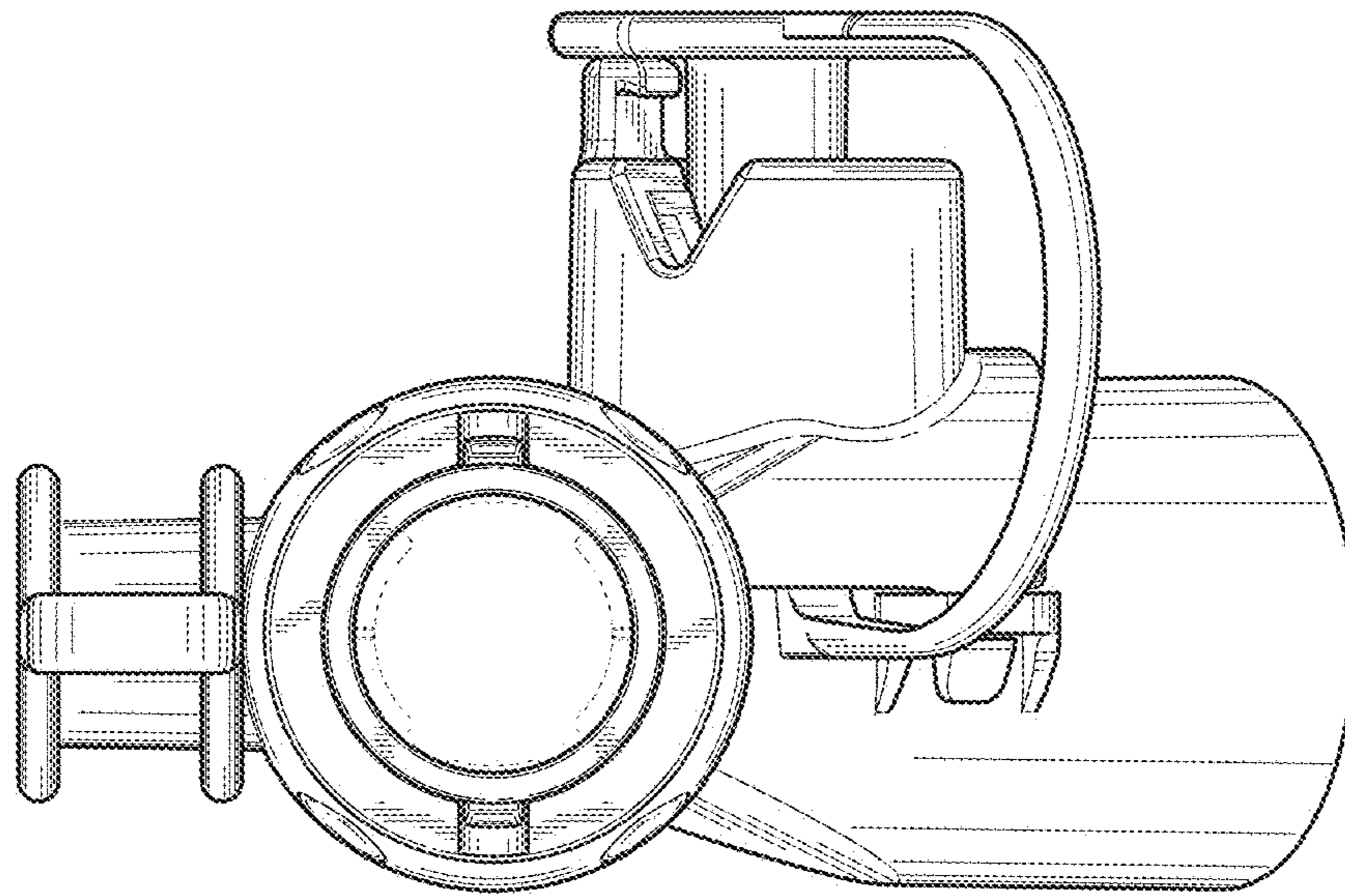

FIG. 7

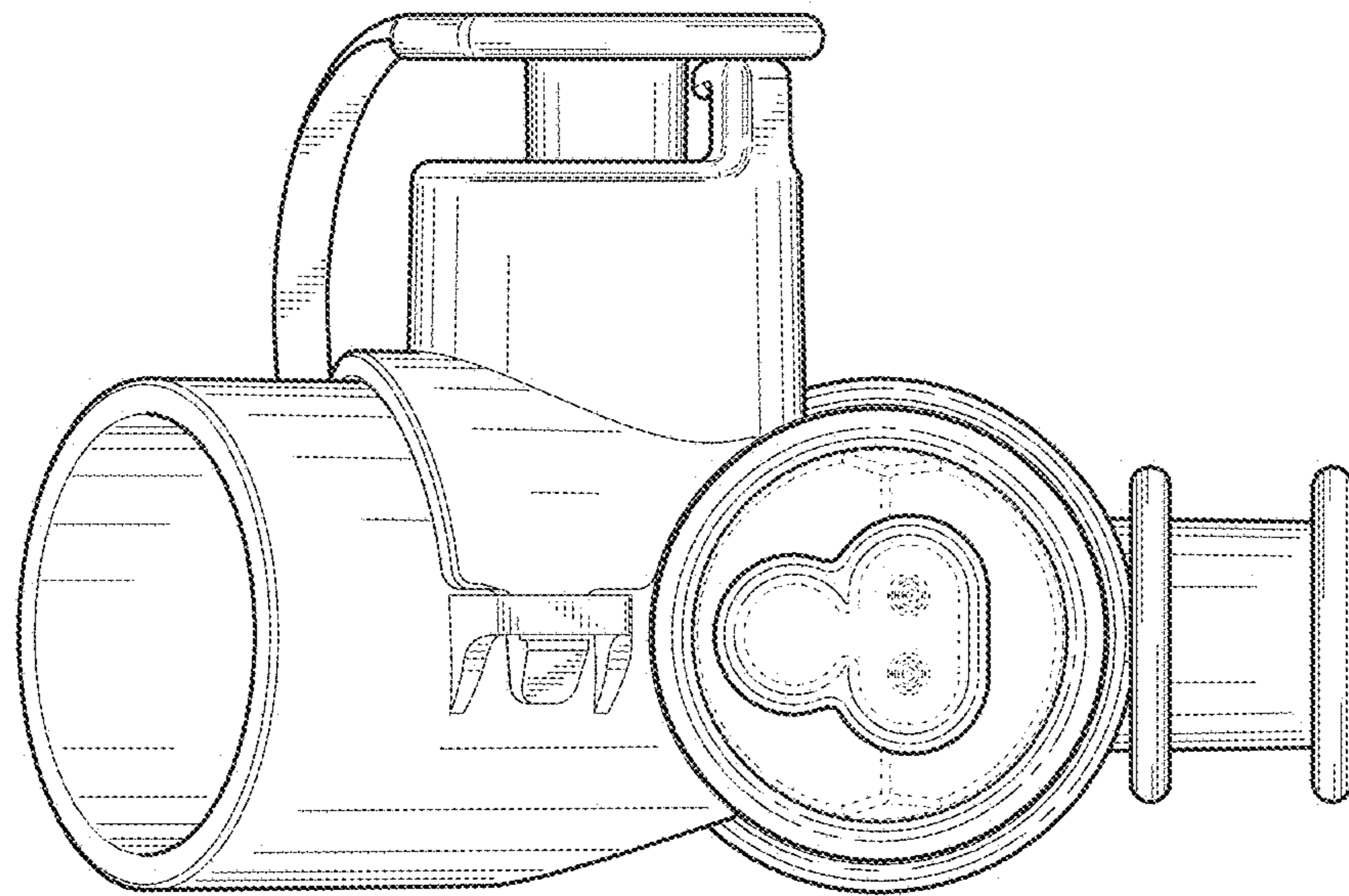

FIG. 8