



US009974230B2

(12) **United States Patent**
Sauder et al.

(10) **Patent No.:** **US 9,974,230 B2**
(45) **Date of Patent:** **May 22, 2018**

(54) **AGRICULTURAL INPUT SELECTION SYSTEMS, METHODS AND APPARATUS**

(71) Applicant: **PRECISION PLANTING LLC**,
Tremont, IL (US)

(72) Inventors: **Derek Sauder**, Tremont, IL (US); **Todd Swanson**, Washington, IL (US); **Troy Plattner**, Goodfield, IL (US)

(73) Assignee: **Precision Planting LLC**, Tremont, IL (US)

(*) Notice: Subject to any disclaimer, the term of this patent is extended or adjusted under 35 U.S.C. 154(b) by 146 days.

(21) Appl. No.: **14/762,459**

(22) PCT Filed: **Jan. 21, 2014**

(86) PCT No.: **PCT/US2014/012363**

§ 371 (c)(1),

(2) Date: **Jul. 21, 2015**

(87) PCT Pub. No.: **WO2014/113803**

PCT Pub. Date: **Jul. 24, 2014**

(65) **Prior Publication Data**

US 2015/0351314 A1 Dec. 10, 2015

Related U.S. Application Data

(60) Provisional application No. 61/754,944, filed on Jan. 21, 2013.

(51) **Int. Cl.**

A01C 7/10 (2006.01)

A01C 7/12 (2006.01)

(Continued)

(52) **U.S. Cl.**

CPC **A01C 7/10** (2013.01); **A01C 7/046** (2013.01); **A01C 7/12** (2013.01); **A01C 21/005** (2013.01)

(58) **Field of Classification Search**

CPC **A01C 21/005**; **A01C 7/10**; **A01C 7/12**
See application file for complete search history.

(56) **References Cited**

U.S. PATENT DOCUMENTS

4,023,509 A 5/1977 Hanson
5,915,313 A * 6/1999 Bender **A01B 79/005**
111/178

(Continued)

FOREIGN PATENT DOCUMENTS

WO 2012129442 A2 9/2012
WO 2012129442 A3 9/2012

(Continued)

OTHER PUBLICATIONS

PCT/US2014/012363 International Search Report and Opinion, dated May 16, 2014.

(Continued)

Primary Examiner — John Weiss

(74) *Attorney, Agent, or Firm* — Thomas J. Oppold;
Larkin Hoffman Daly & Lindgren, Ltd.

(57) **ABSTRACT**

Systems, methods and apparatus for selecting an agricultural input. First and second inputs are in communication with a seed meter. A selection apparatus constrains the seed meter to deposit only one of the input sources such that the seed meter is enabled to alternate between depositing the first and second inputs. Processing circuitry controls the selection apparatus to alternate between the first and second inputs.

4 Claims, 17 Drawing Sheets

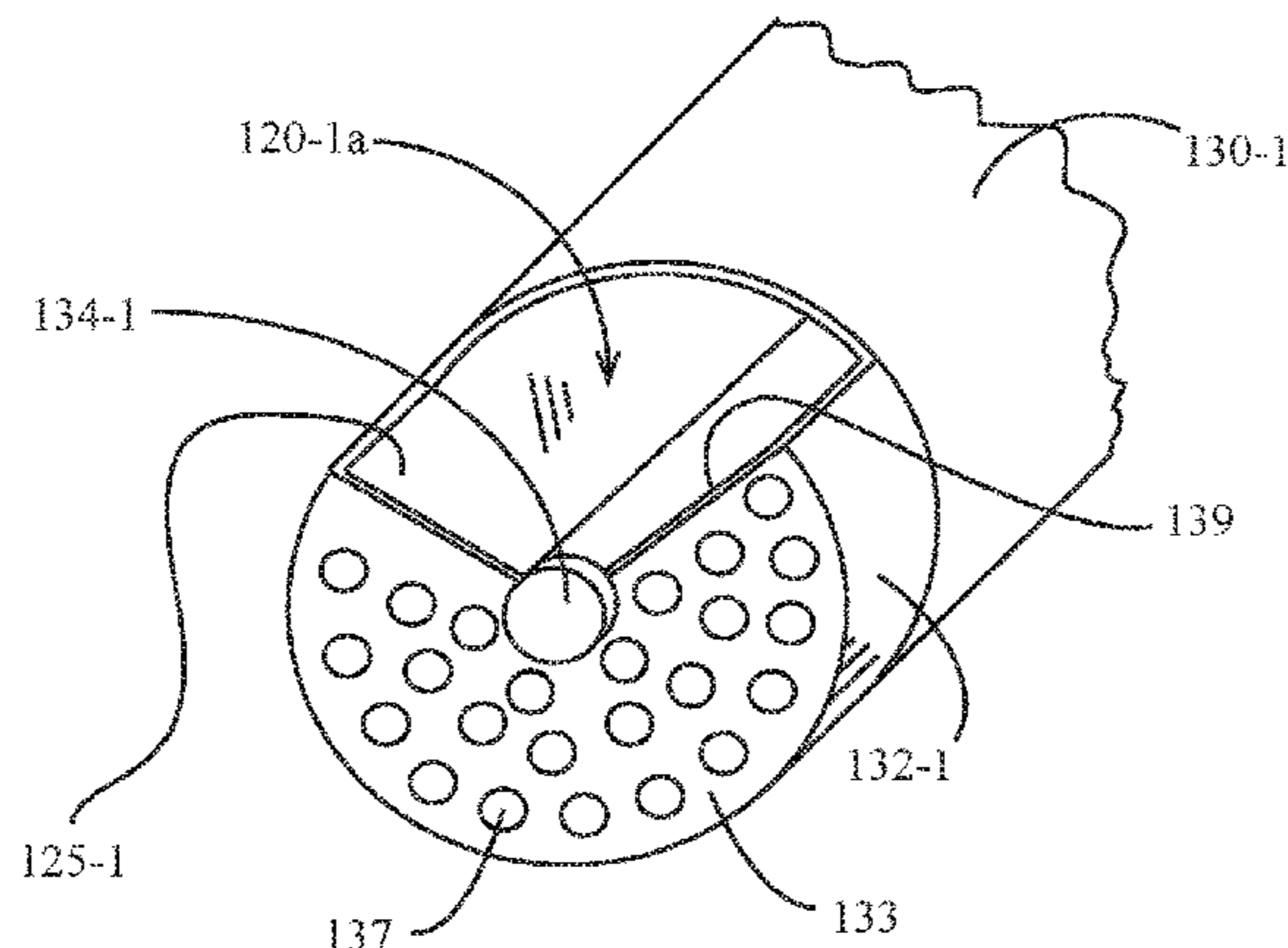

(51) **Int. Cl.**
A01C 7/04 (2006.01)
A01C 21/00 (2006.01)

2006/0278726 A1 12/2006 Holly
2007/0048434 A1 3/2007 Mayerle et al.
2011/0098851 A1 4/2011 Glendenning et al.
2011/0178632 A1 7/2011 Straeter
2014/0165889 A1 6/2014 Garner et al.
2014/0165890 A1 6/2014 Graham
2015/0319916 A1 11/2015 Garner et al.

(56) **References Cited**

U.S. PATENT DOCUMENTS

6,070,539 A * 6/2000 Flamme A01B 79/005
111/177
6,164,222 A 12/2000 Mayerle et al.
6,516,733 B1 * 2/2003 Sauder A01C 21/005
111/180
6,626,120 B2 9/2003 Bogner et al.
7,418,908 B2 * 9/2008 Landphair A01C 15/006
111/175
7,938,075 B1 * 5/2011 Glendenning A01C 7/046
111/185
8,948,980 B2 * 2/2015 Garner A01C 7/08
111/185

FOREIGN PATENT DOCUMENTS

WO 2014093657 A1 6/2014
WO 2014093754 A1 6/2014
WO 2014100796 A1 6/2014

OTHER PUBLICATIONS

EP14740635.9 Extended European Search Report, dated Oct. 11, 2016.

* cited by examiner

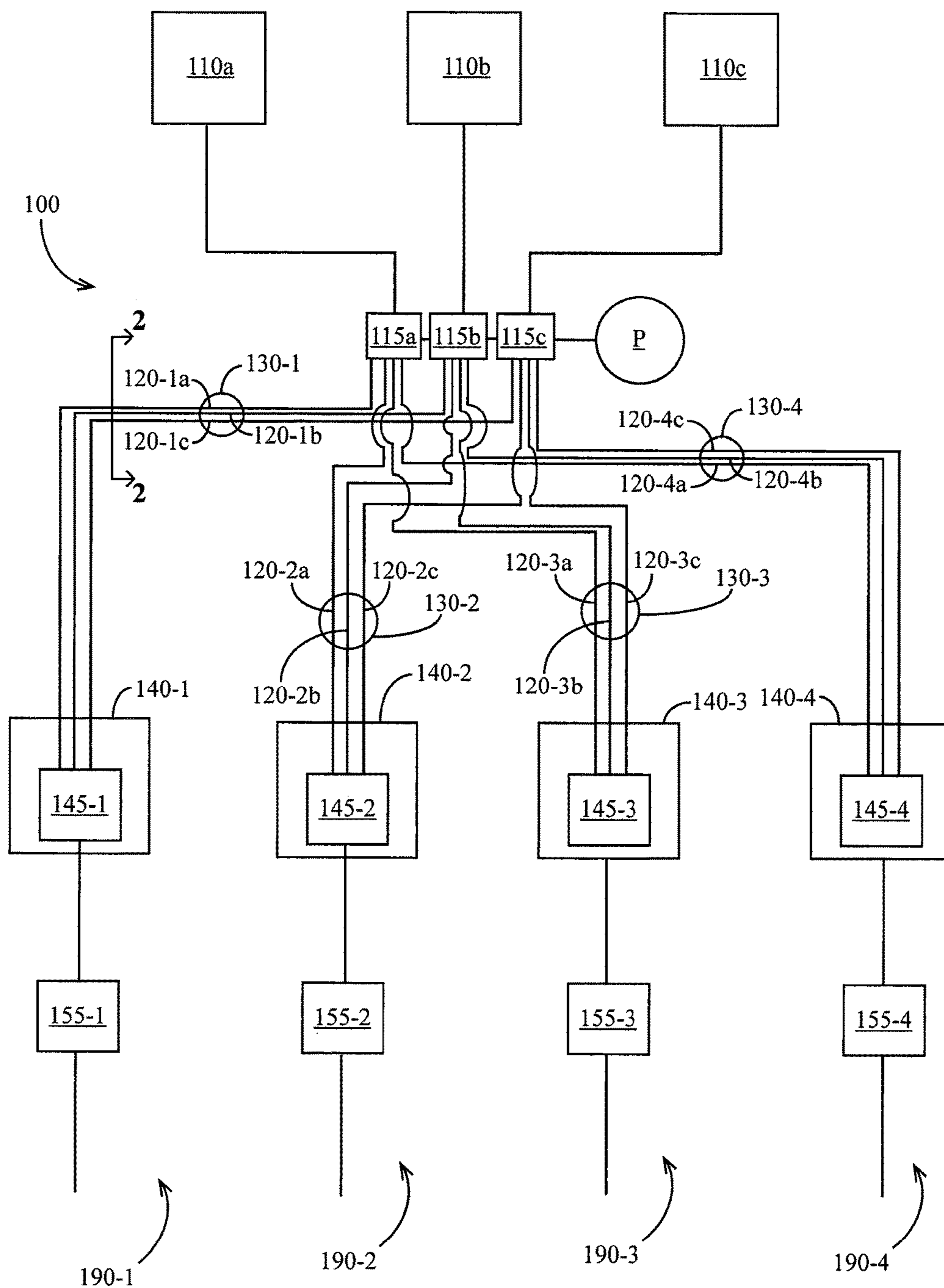

FIG. 1

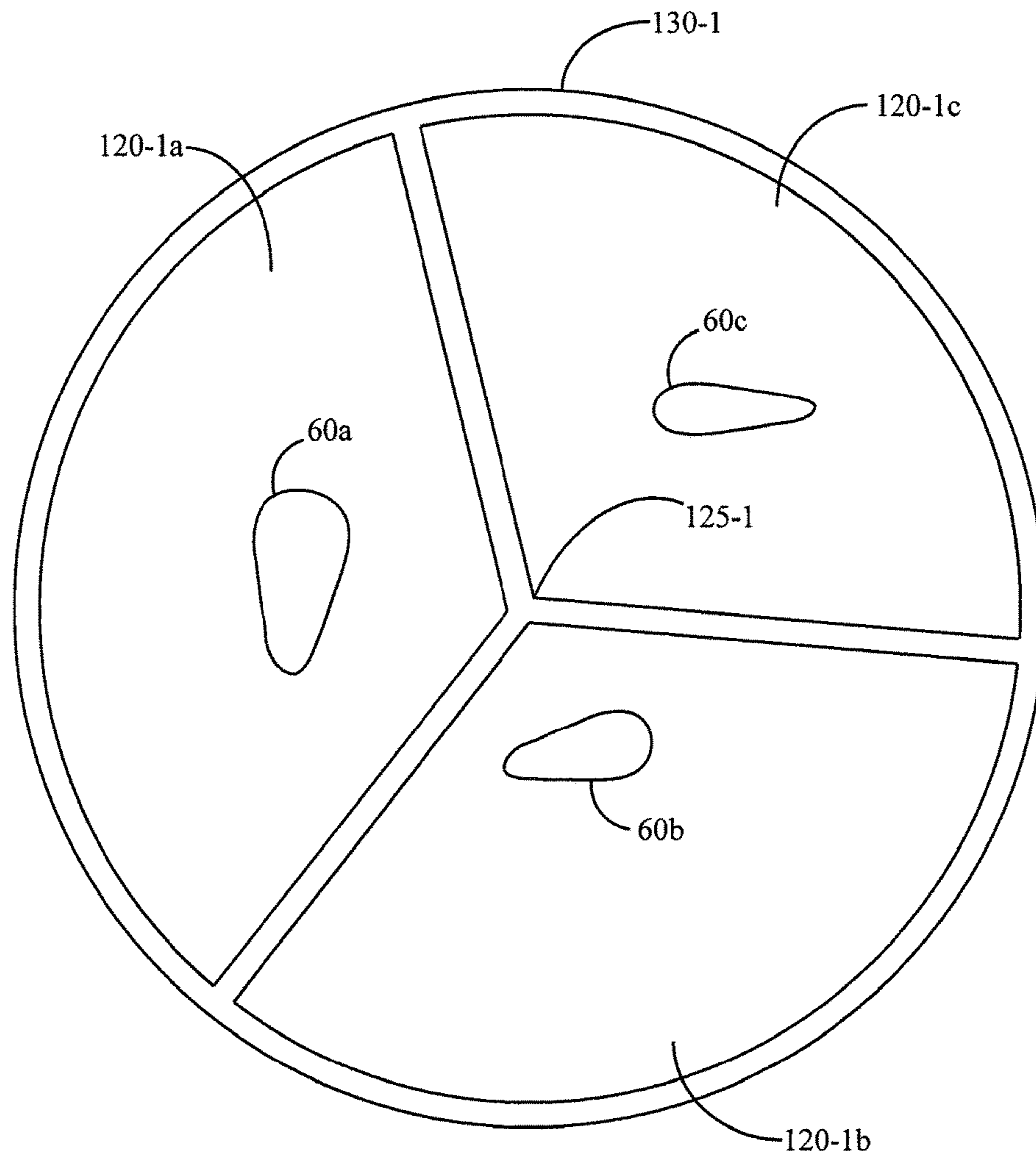

FIG. 2

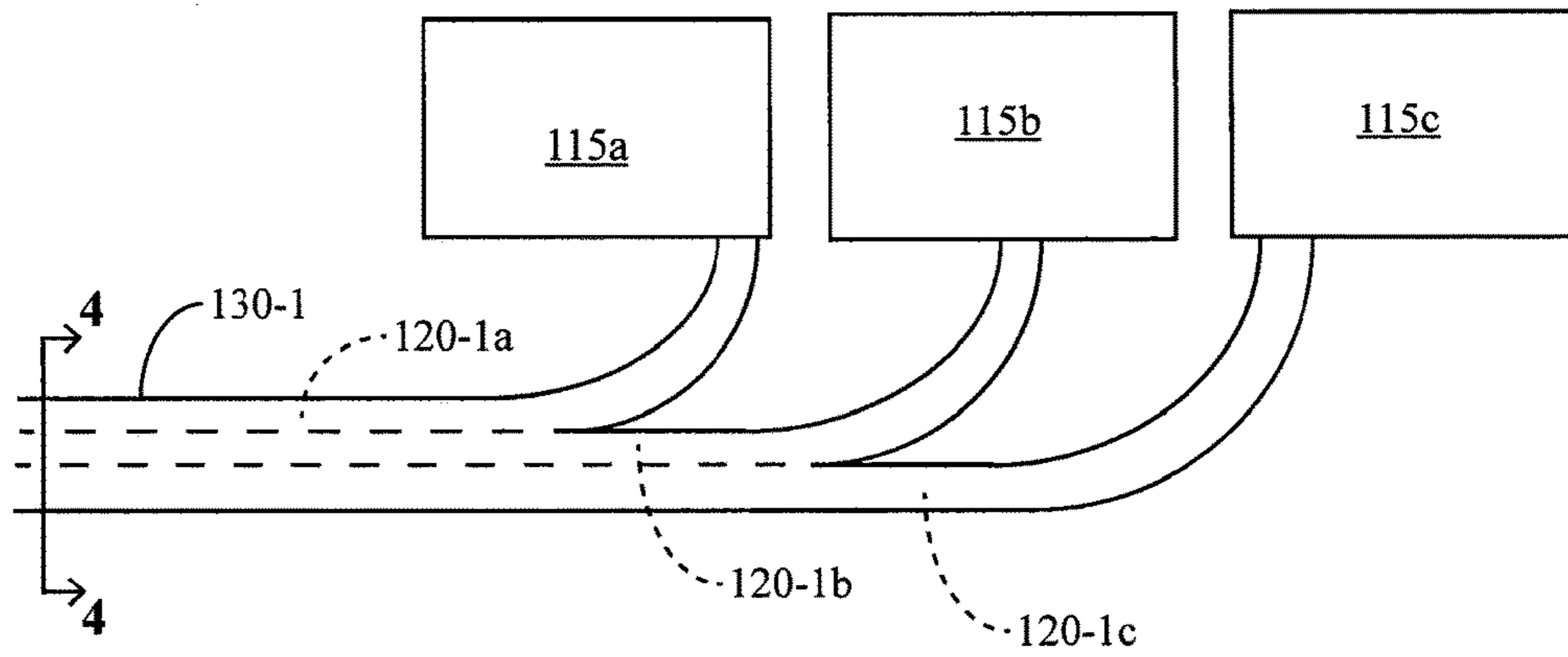

FIG. 3

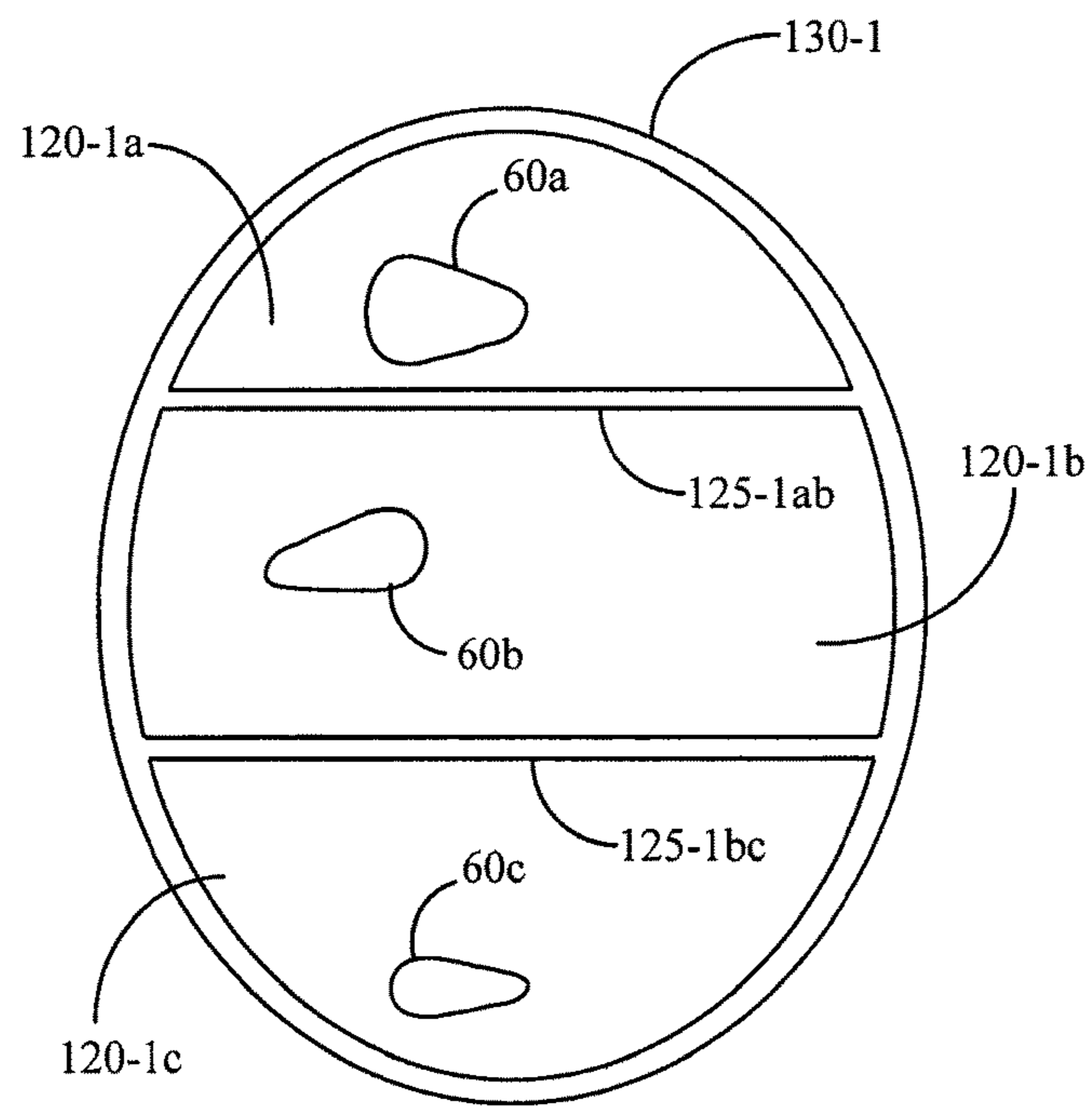

FIG. 4

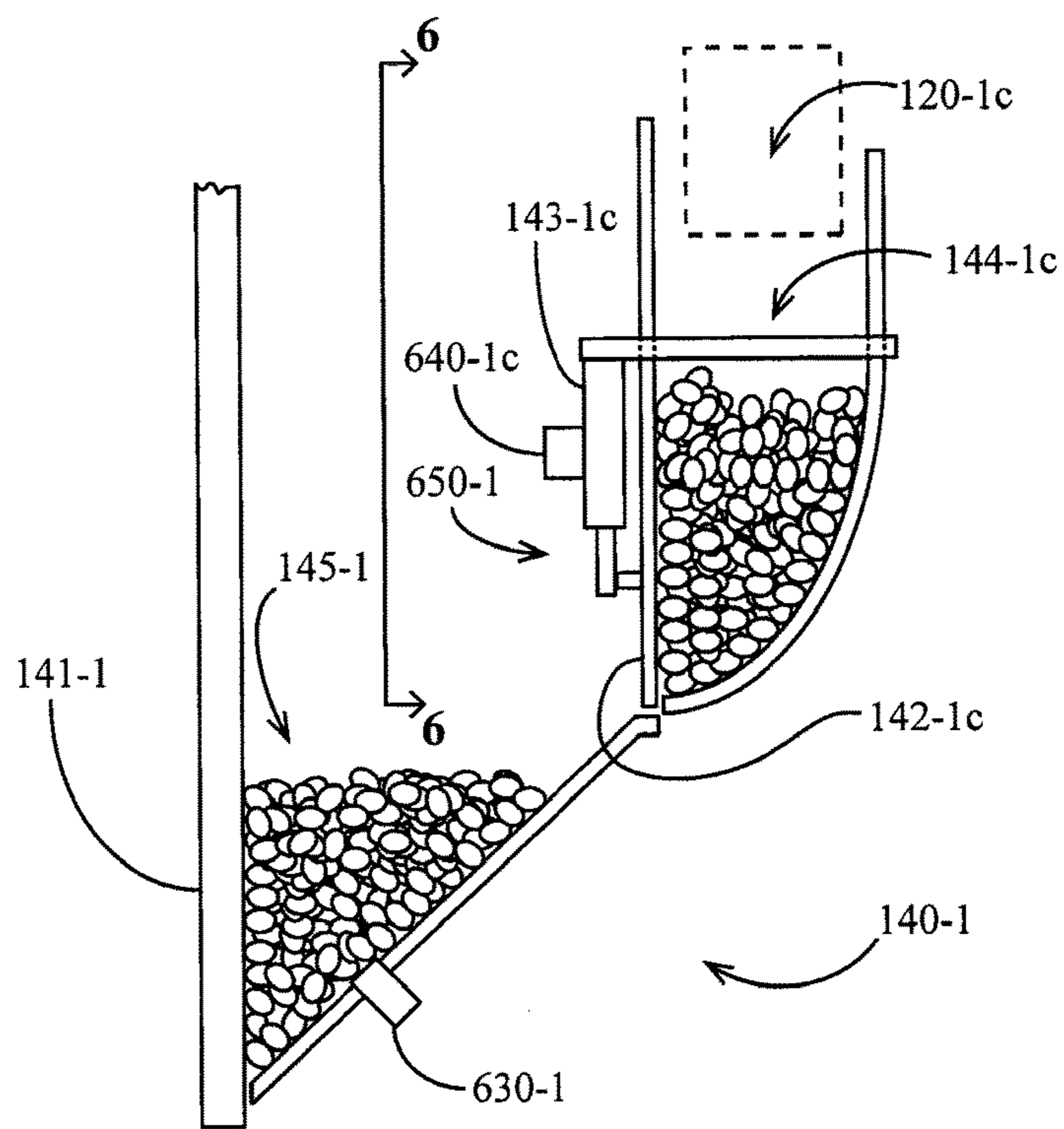

FIG. 5

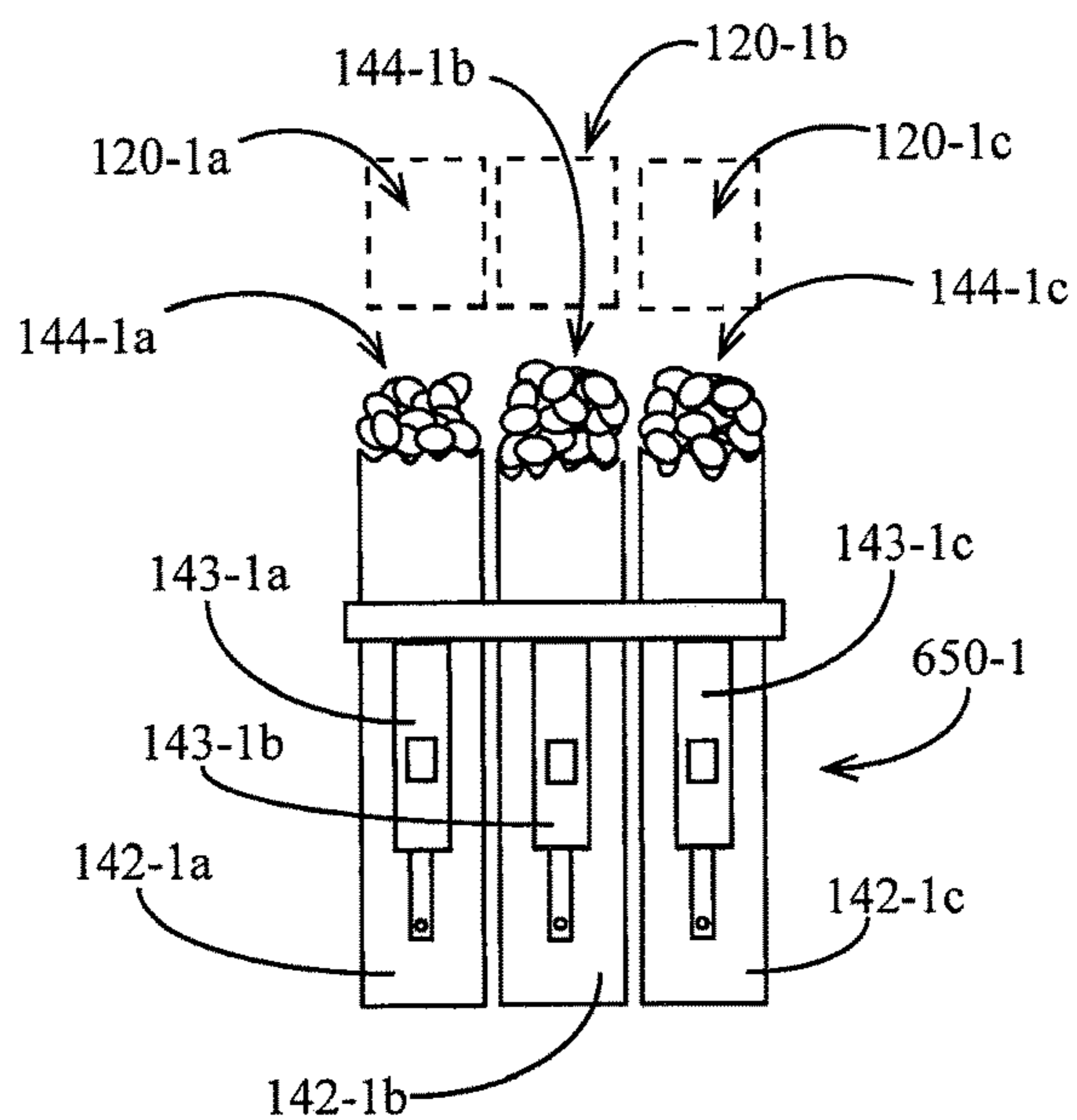

FIG. 6

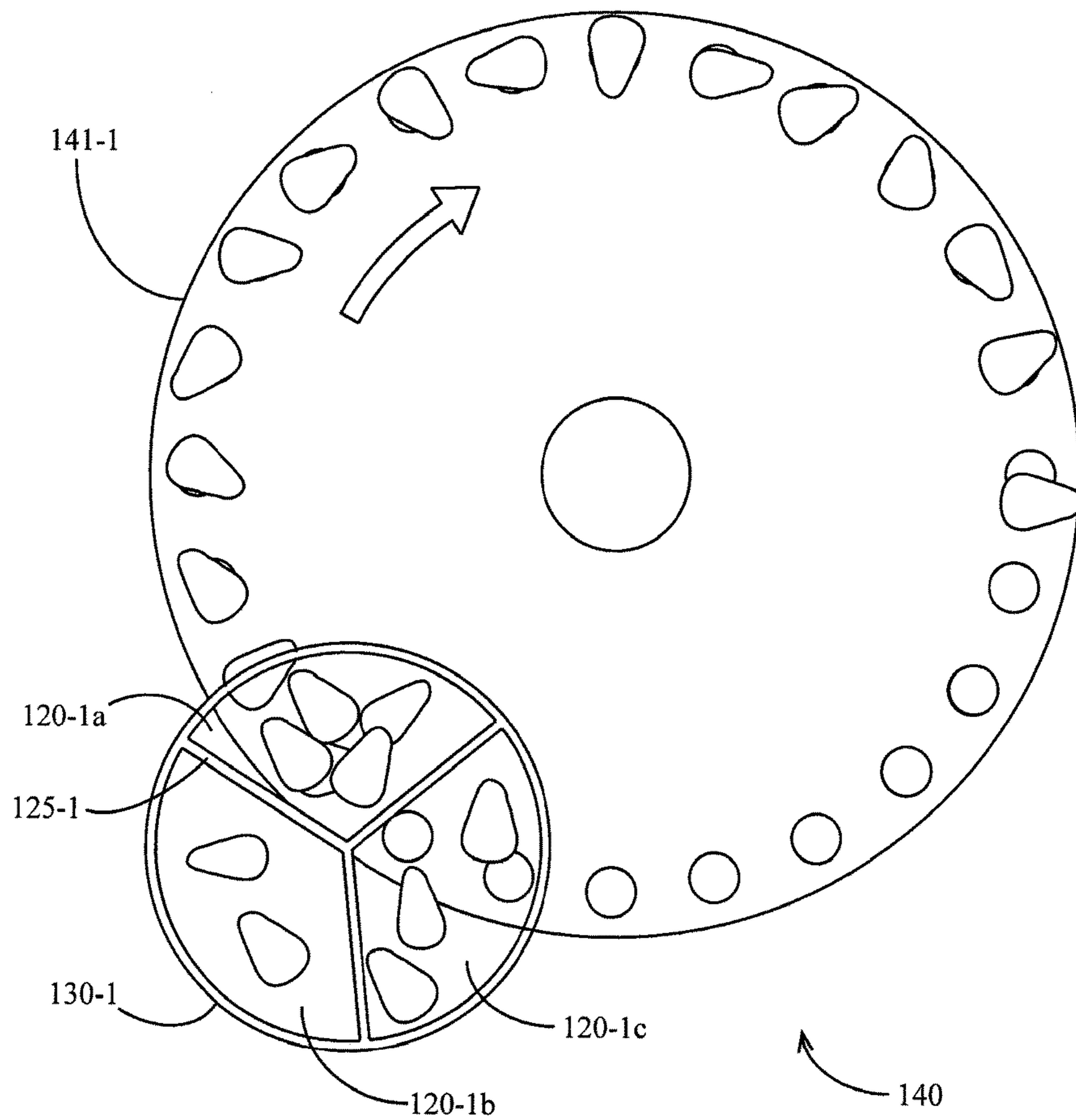

FIG. 7A

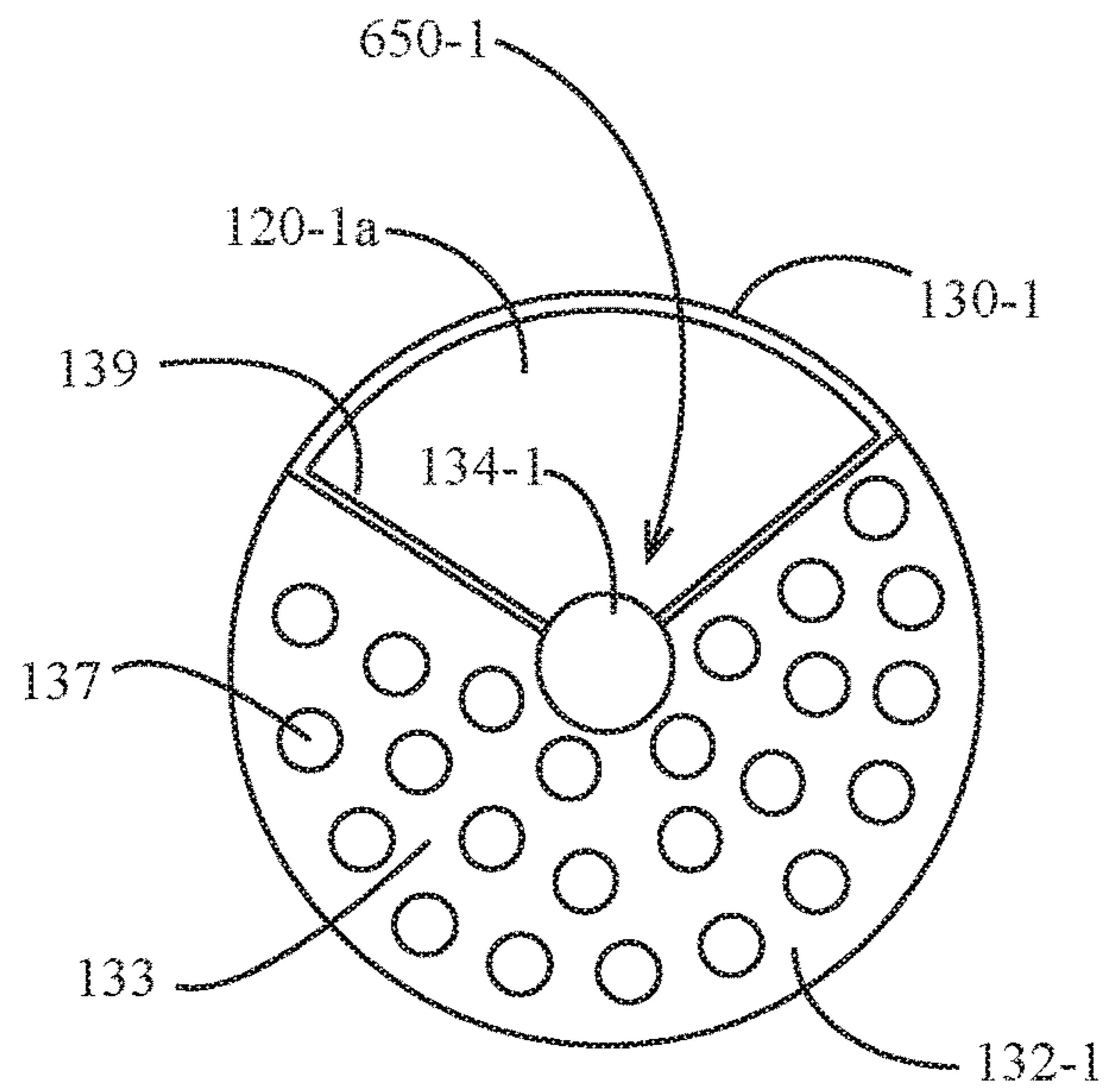

FIG. 7B

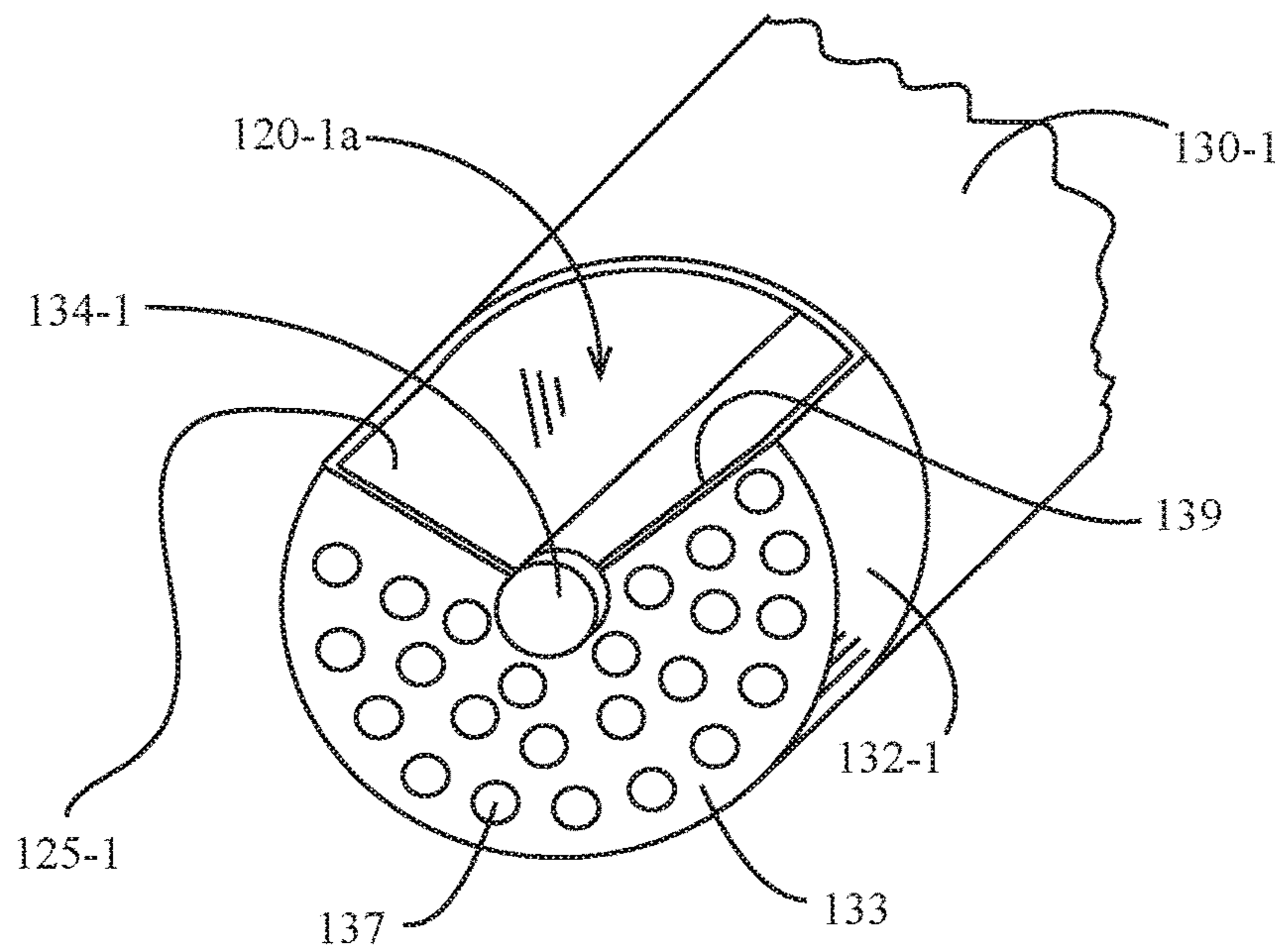

FIG. 7C

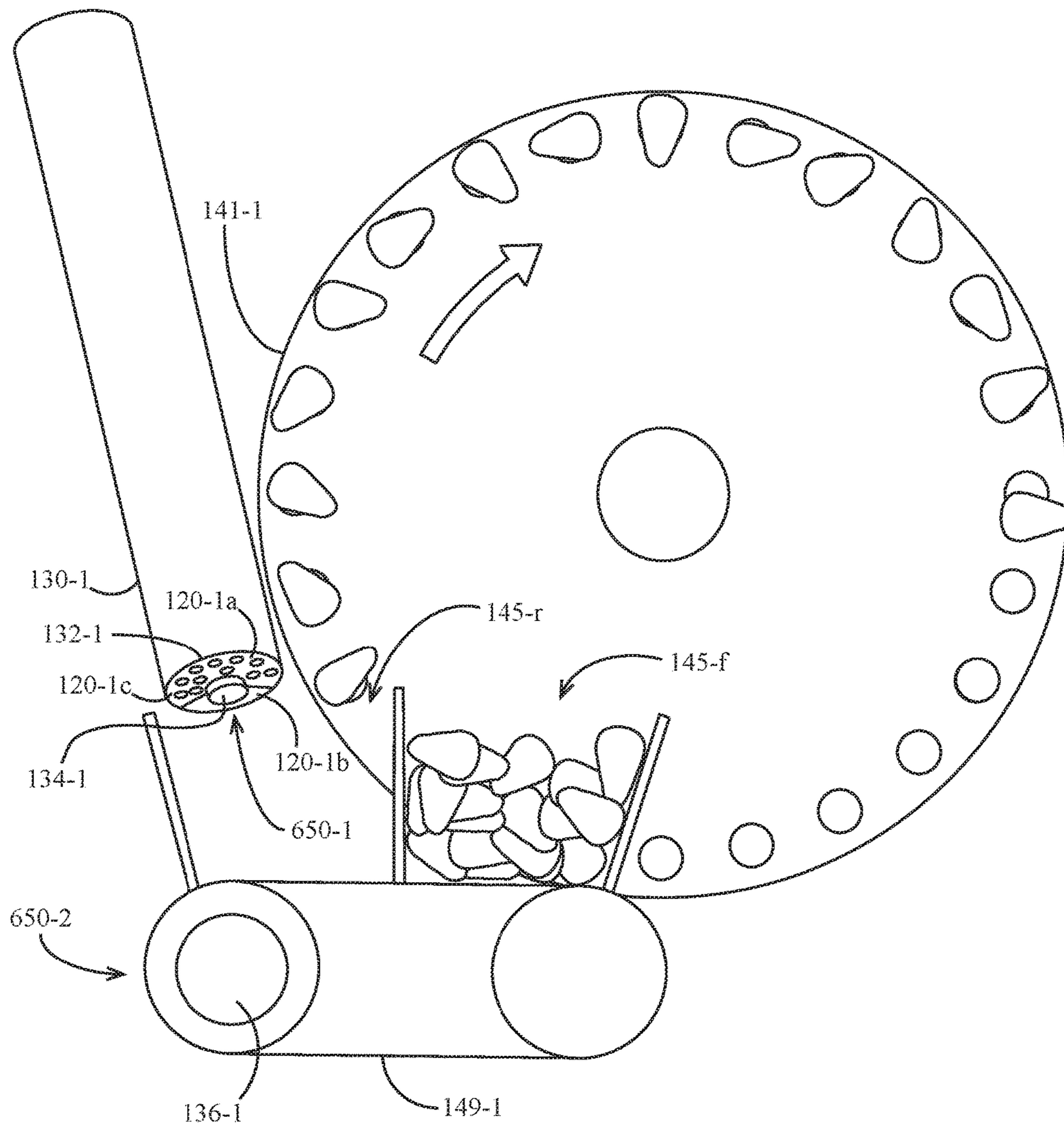

FIG. 8

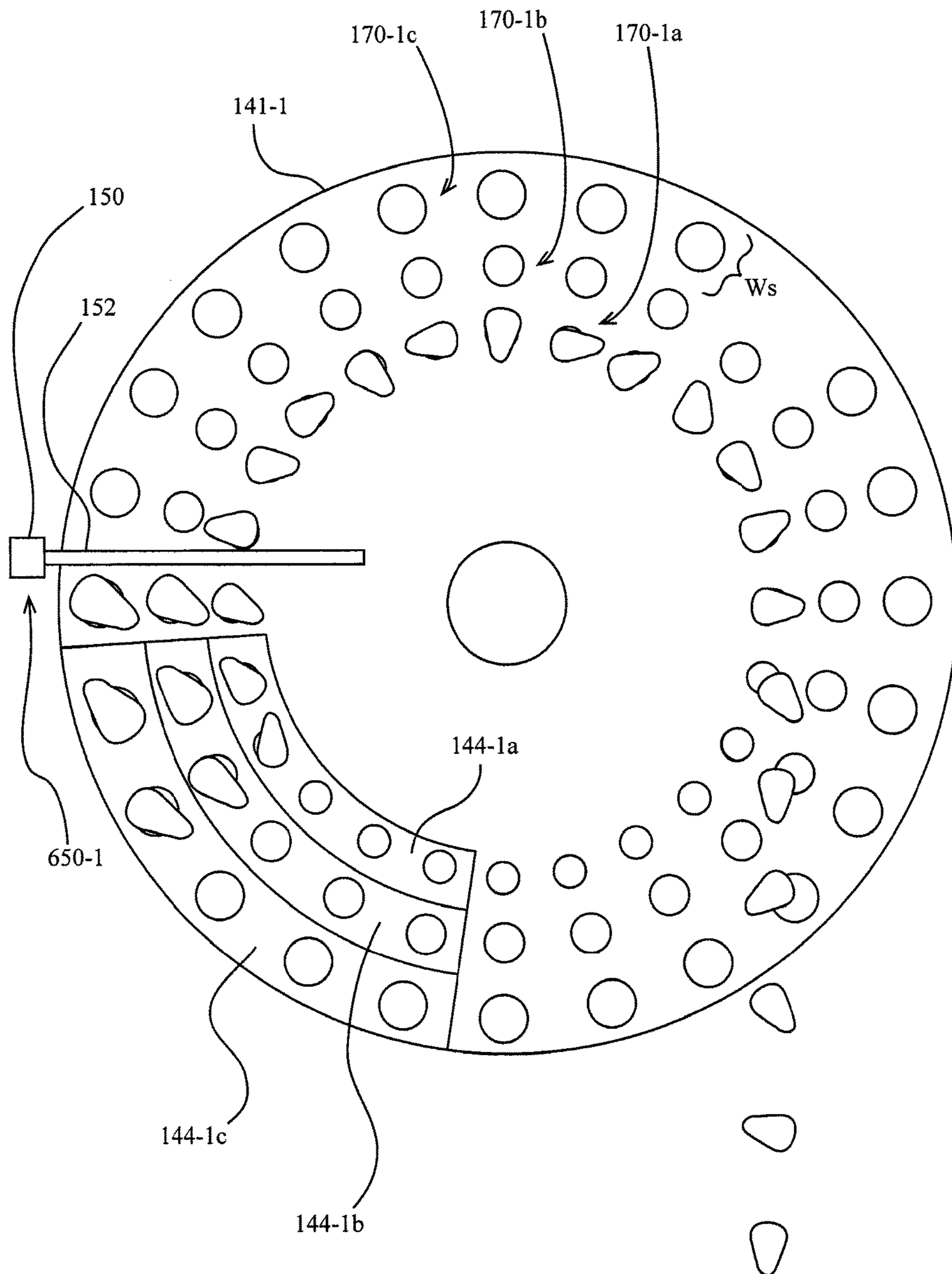

FIG. 9

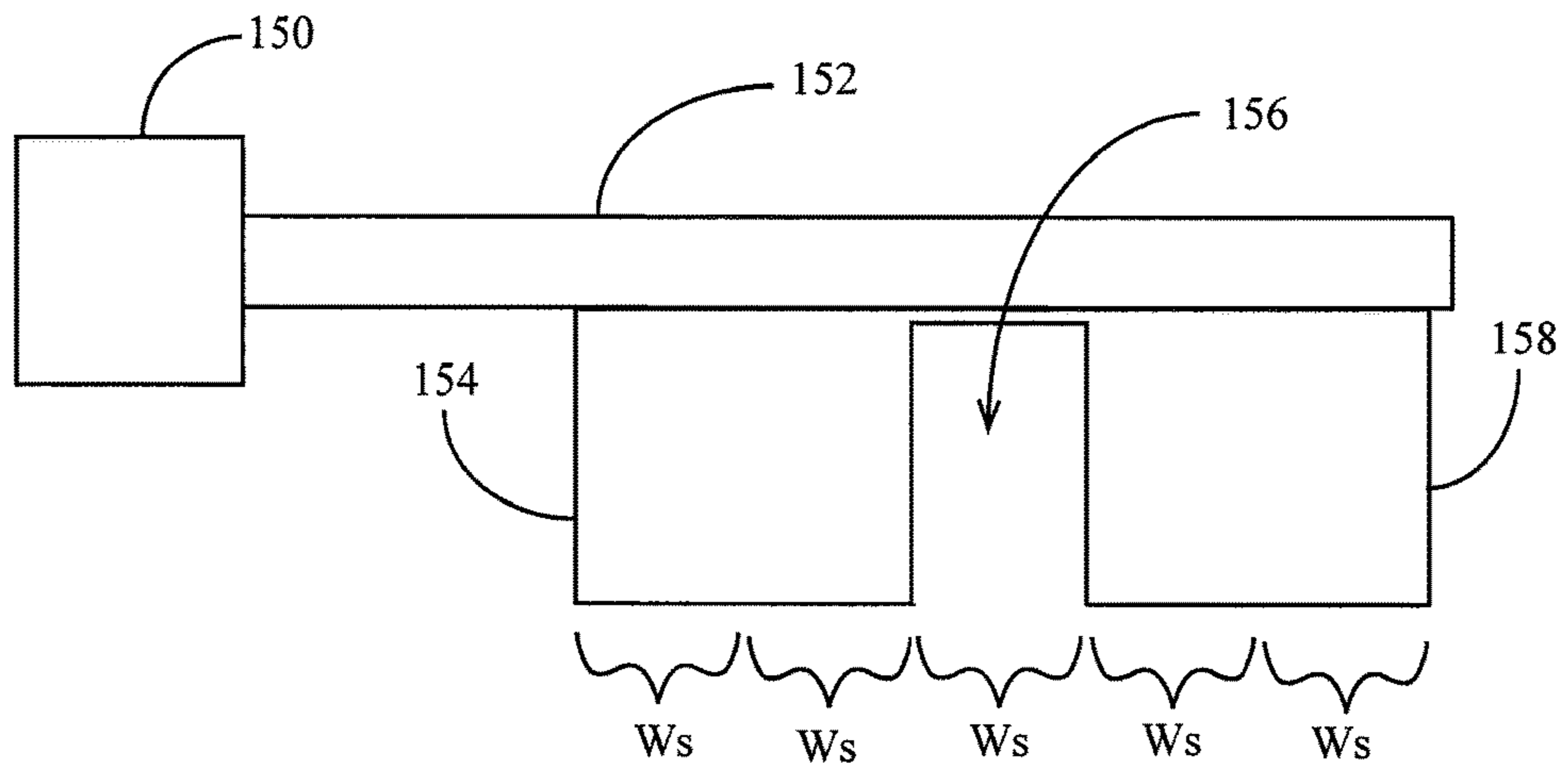

FIG. 10

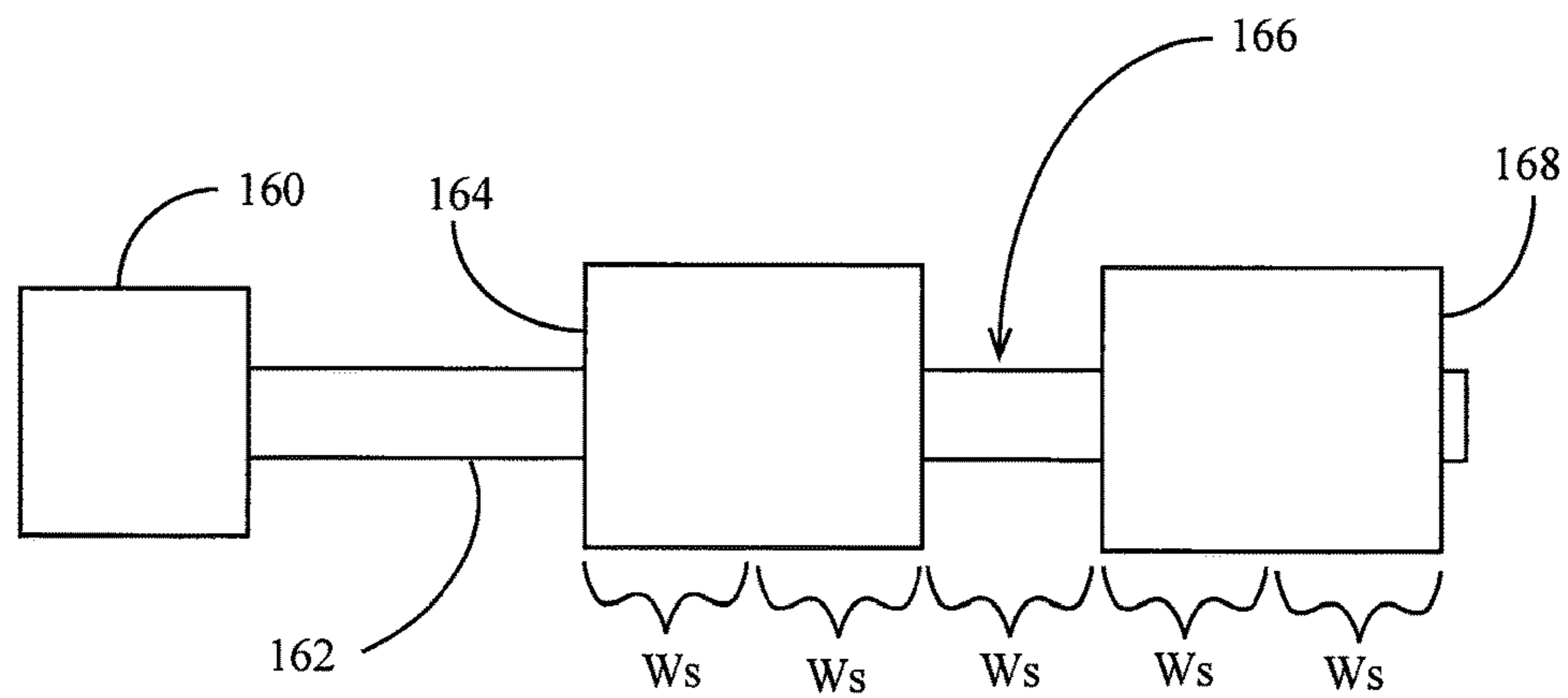

FIG. 12

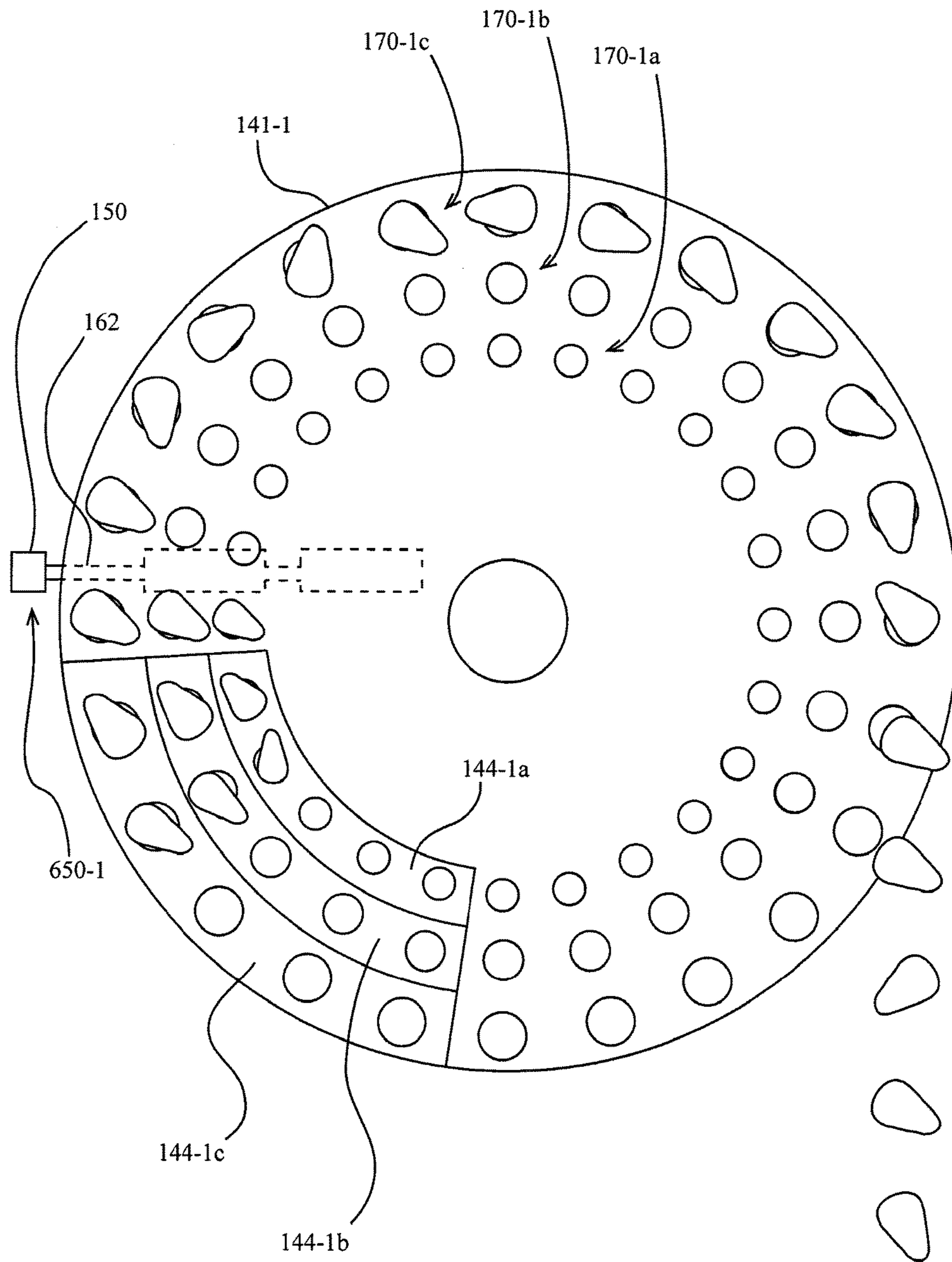

FIG. 11

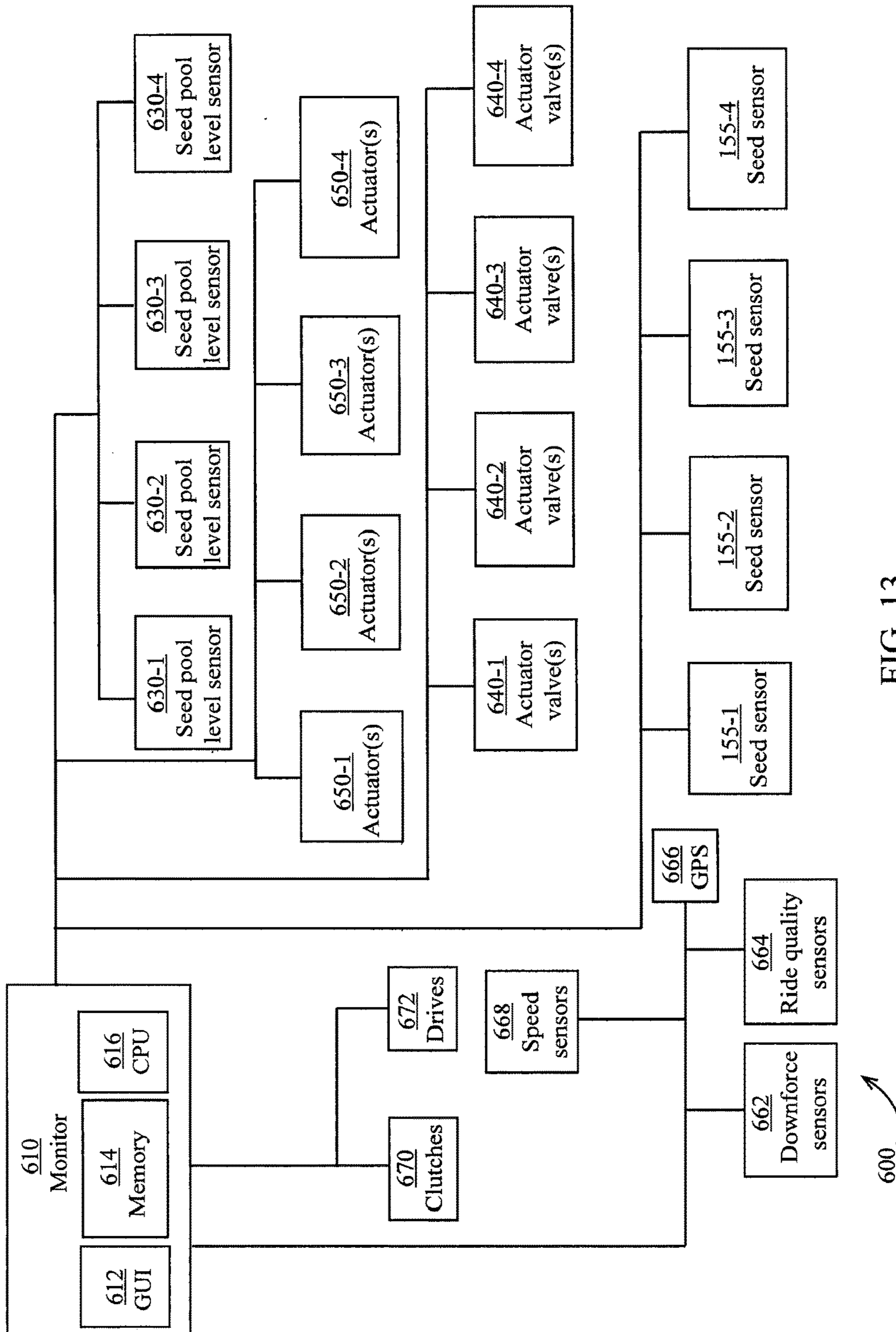

FIG. 13

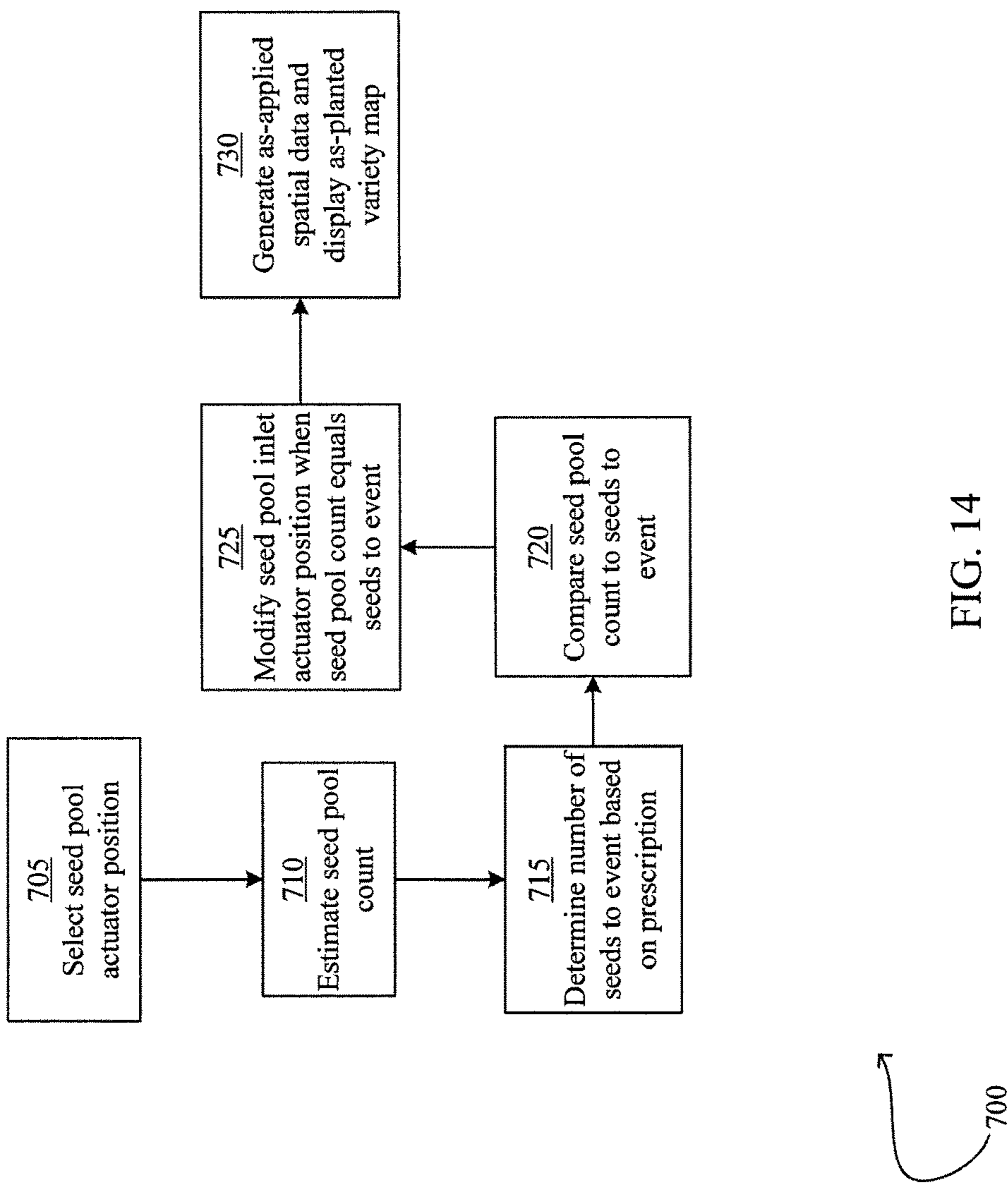

FIG. 14

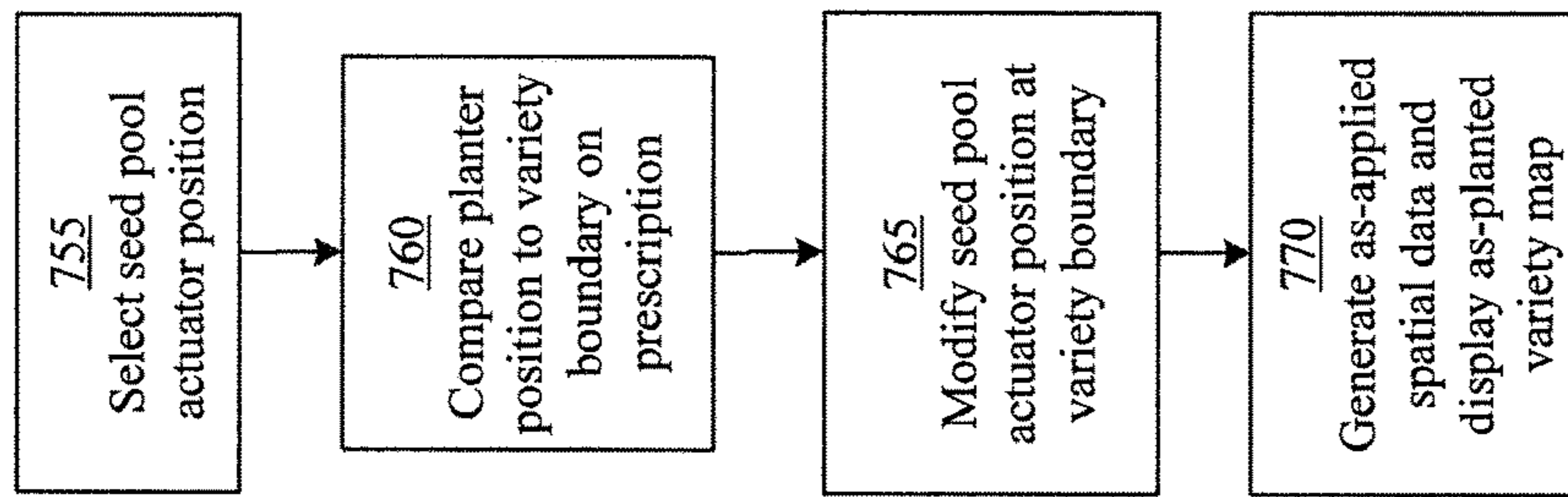
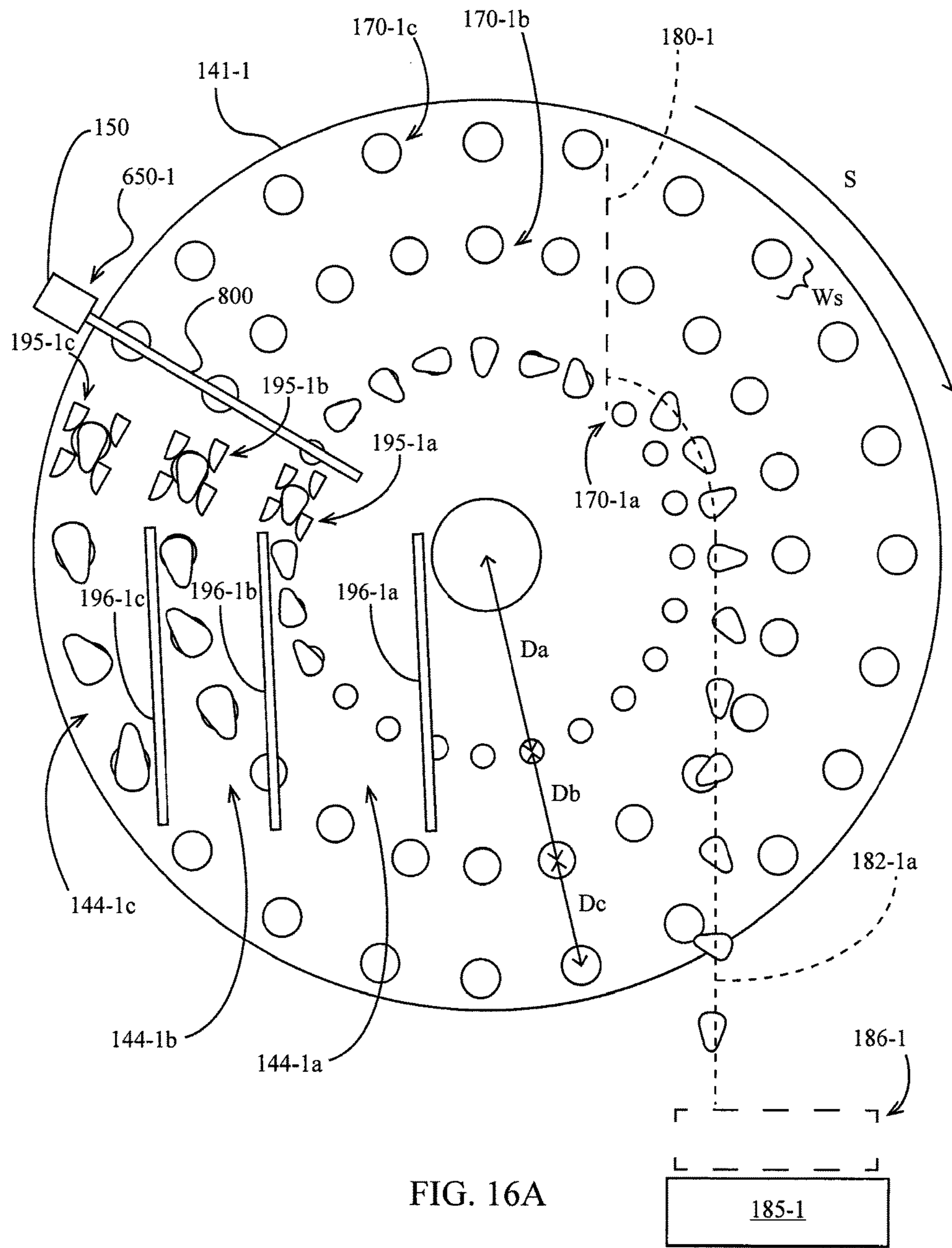

FIG. 15

750



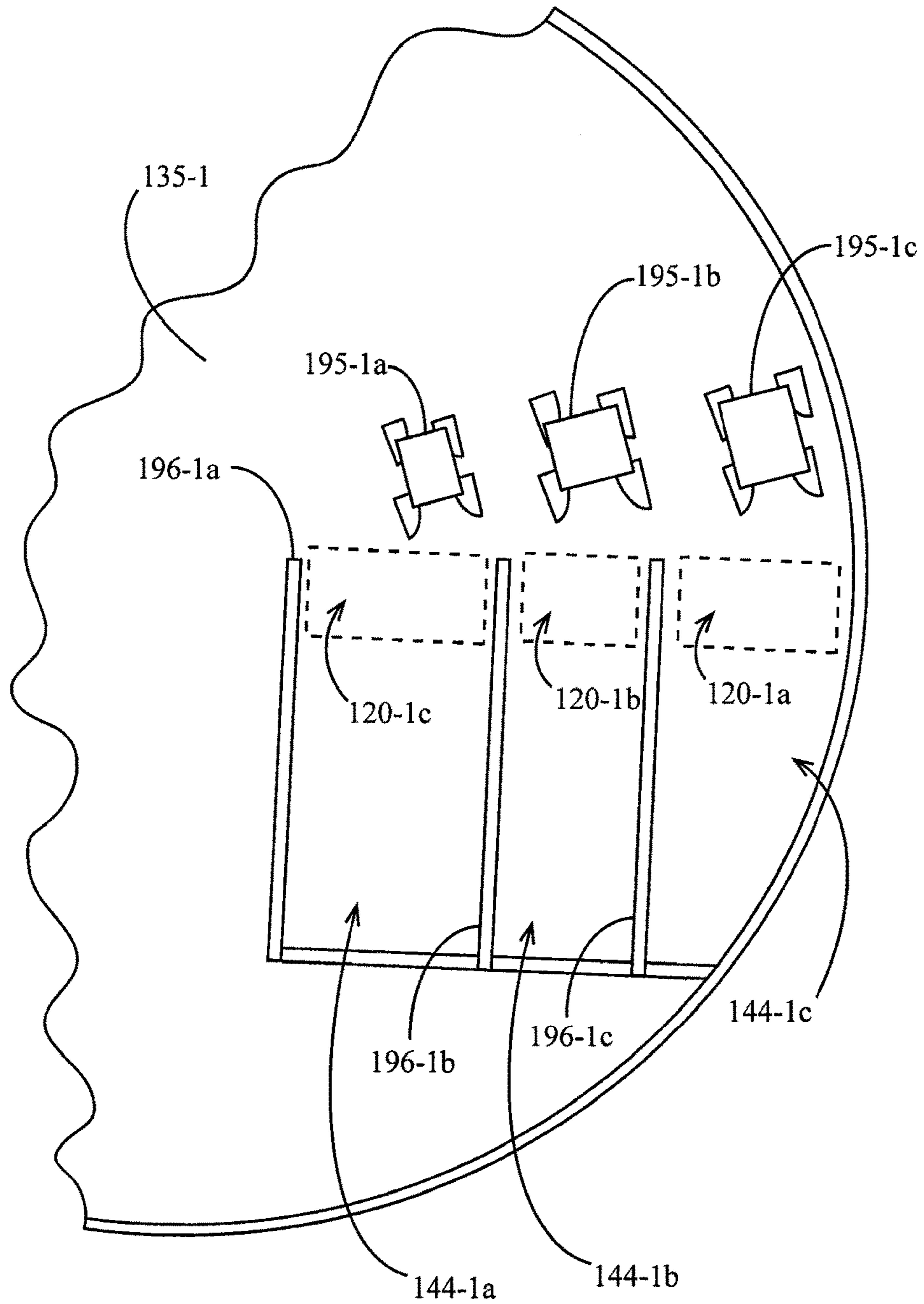

FIG. 16B

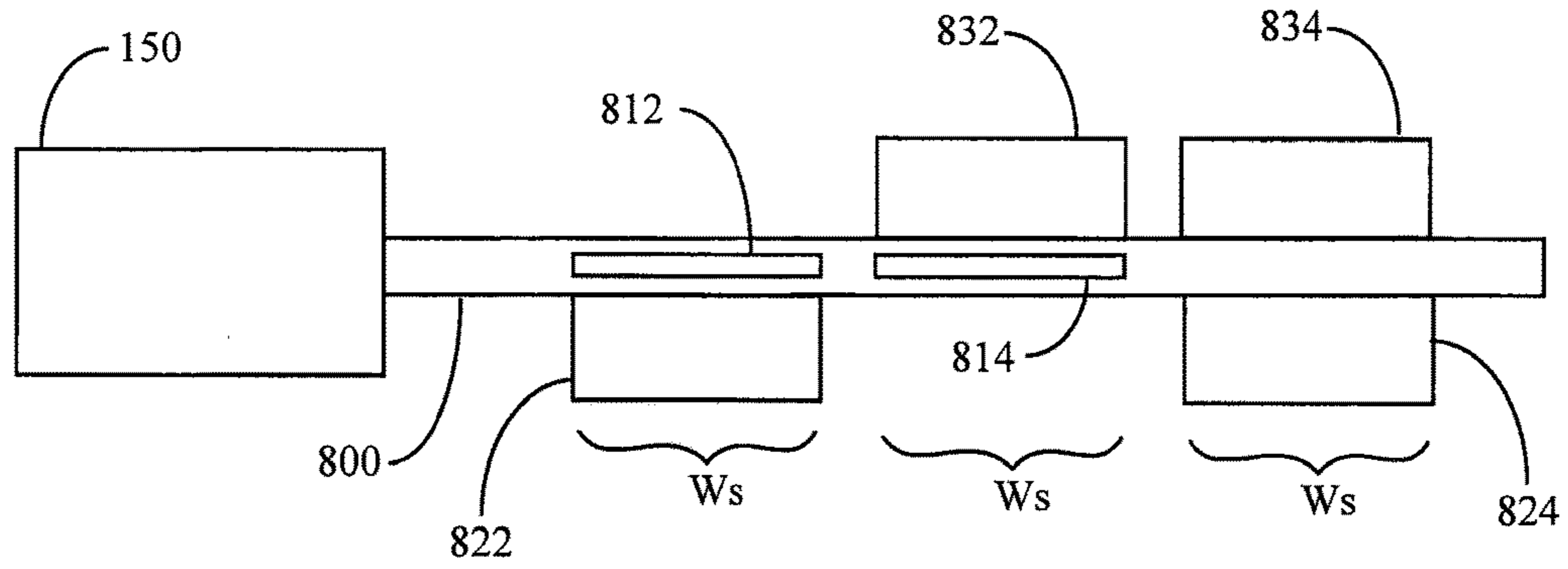

FIG. 17A

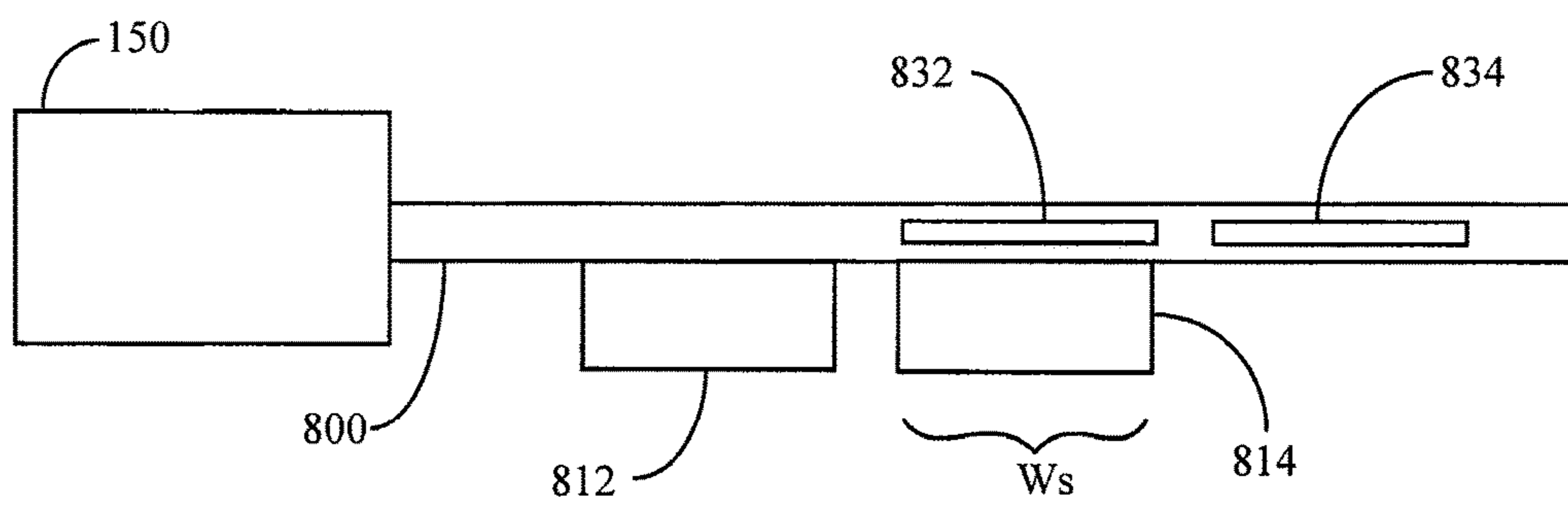

FIG. 17B

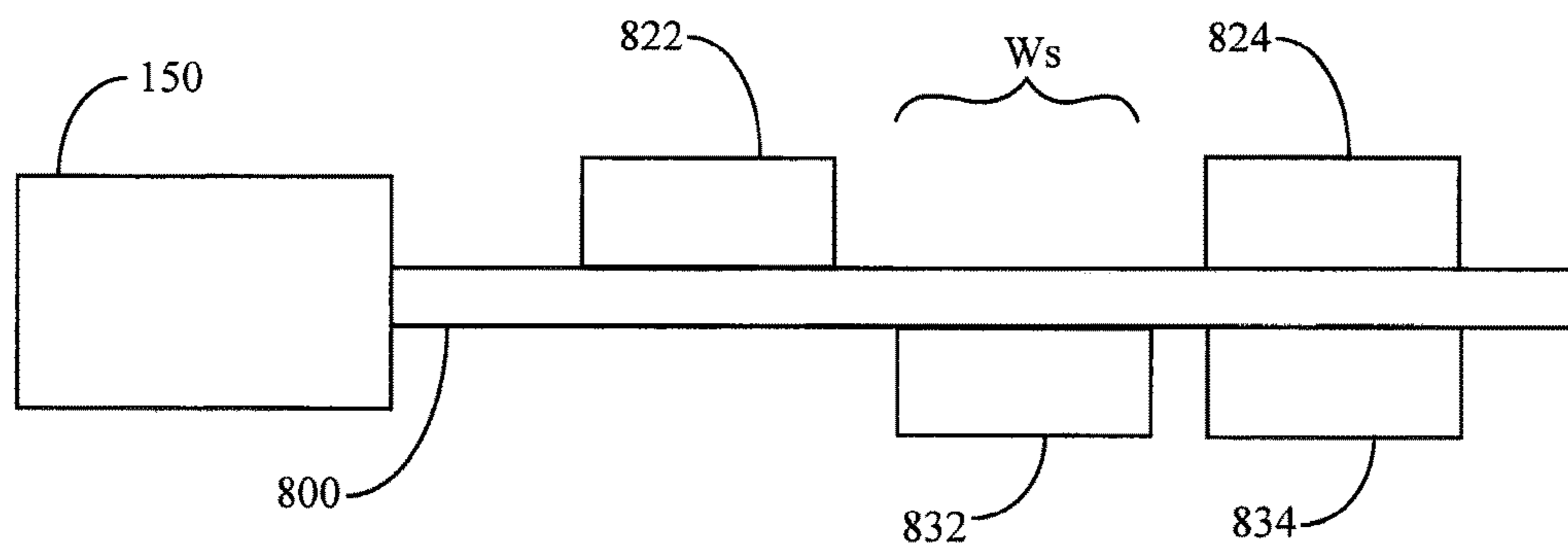
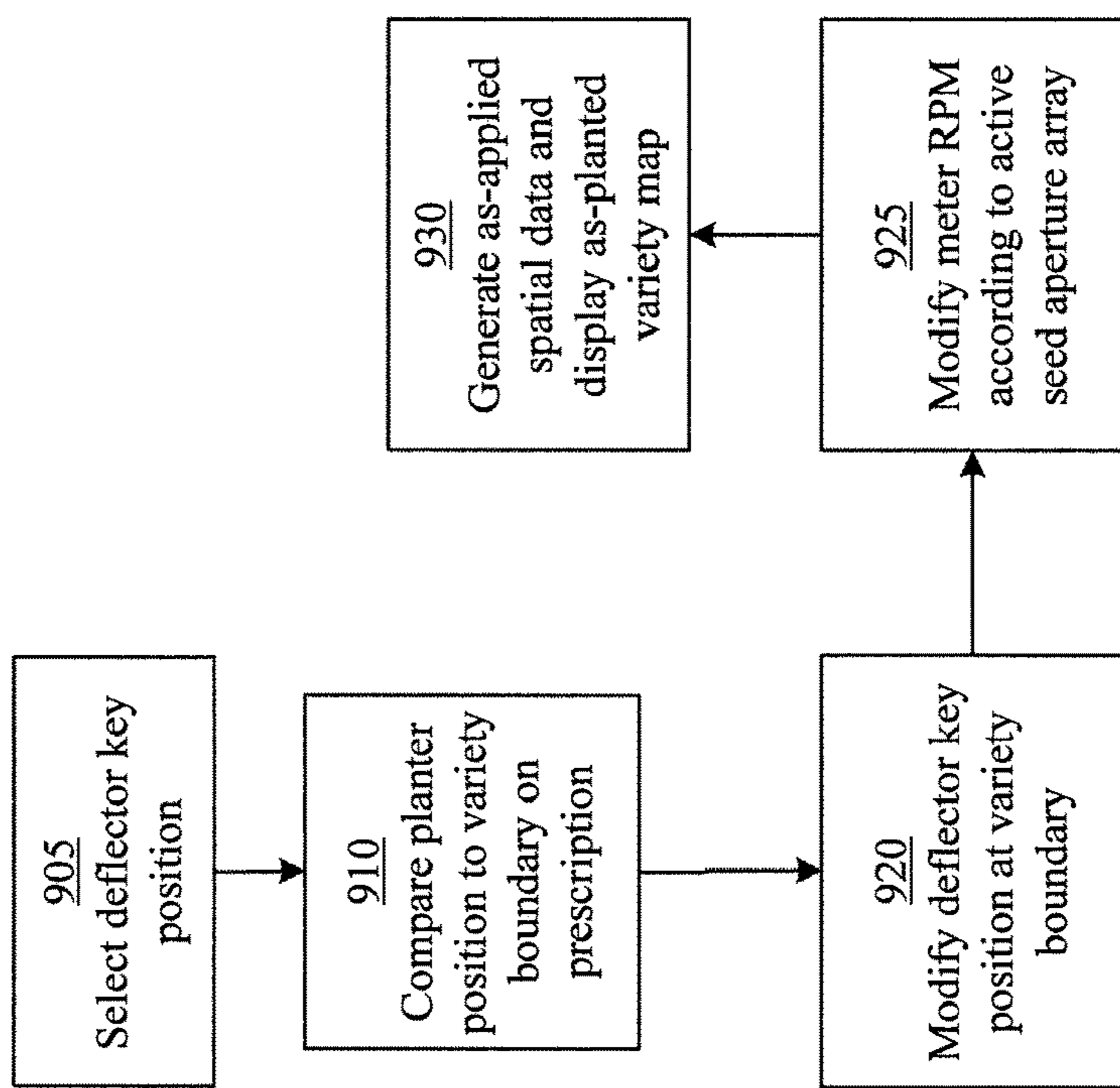

FIG. 17C



900

FIG. 18

AGRICULTURAL INPUT SELECTION SYSTEMS, METHODS AND APPARATUS

BACKGROUND

In recent years, the ability to control crop input applications on a site-specific basis (known as “precision farming”) has increased interest in varying input types throughout a field. In particular, advances in seed genetics and agronomic research have increased the need for solutions enabling the variation of seed types in the field during a planting operation. Prior proposed solutions such as those disclosed in U.S. Pat. No. 8,543,238 require multiple meters at each row unit and are relatively slow to transition between seed types. Other proposed solutions involve shifting between input types fed to the metering units, which results in blending of input types at the metering units and thus blended input regions in the field. Preferred solutions would quickly transition between input types with limited blending between seed types.

Thus there is a need in the art for systems, methods and apparatus for effectively selecting and varying agricultural input types during an in-field operation.

DESCRIPTION OF THE DRAWINGS

FIG. 1 schematically illustrates an embodiment of an agricultural input selection system.

FIG. 2 illustrates a cross-section of an embodiment of a segregated pneumatic line as viewed along line 2-2 of FIG. 1.

FIG. 3 illustrates a portion of an embodiment of another embodiment of a segregated pneumatic line.

FIG. 4 illustrates the segregated pneumatic line as viewed along line 4-4 of FIG. 3.

FIG. 5 illustrates a cross-sectional view of an embodiment of a seed meter having three segregated seed pools and a central seed pool.

FIG. 6 illustrates an expanded partial view of the seed meter embodiment as viewed along line 6-6 of FIG. 5.

FIG. 7A is a partial side elevation view of another embodiment of seed in direct selective seed communication with a segregated pneumatic line.

FIG. 7B is a side elevation view of the end of a segregated pneumatic line in seed communication with the seed meter embodiment of FIG. 7A.

FIG. 7C is a perspective view of the end of a segregated pneumatic line in seed communication with the seed meter embodiment of FIG. 7A.

FIG. 8 is a side elevation view of an embodiment of a seed meter including a pair of shifting seed pools in selective seed communication with a pneumatic line and in selective seed communication with a seed disc.

FIG. 9 is a side elevation view of an embodiment of a seed meter including multiple seed pools and a deflector key.

FIG. 10 a top plan view of the deflector key of FIG. 9.

FIG. 11 is a side elevation view of an embodiment of a seed meter including multiple seed pools and a vacuum cutoff roller key.

FIG. 12 is a top plan view of the vacuum cutoff roller key of FIG. 11.

FIG. 13 schematically illustrates an embodiment of an electrical system for selecting seed varieties.

FIG. 14 illustrates an embodiment of a process for implementing and mapping seed variety selections.

FIG. 15 illustrates another embodiment of a process for implementing and mapping seed variety selections.

FIG. 16A is a side elevation view of another embodiment of a seed meter including multiple seed pools and a deflector key.

FIG. 16B is an enlarged partial side elevation view of a seed side housing of the seed meter of FIG. 16A.

FIG. 17A-17C are orthographic views of the deflector key of FIG. 16A.

FIG. 18 illustrates another embodiment of a process for implementing and mapping seed variety selections.

DESCRIPTION

Referring now to the drawings, wherein like reference numerals designate identical or corresponding parts throughout the several views, FIG. 1 schematically illustrates a variety selection system 100. The variety selection system 100 is preferably mounted to a pneumatic seed delivery planter similar to that disclosed in U.S. Pat. No. 7,779,770, the disclosure of which is incorporated herein by reference, which planter is preferably drawn through the field by a tractor (not shown).

Variety Selection Systems

The variety selection system 100 preferably includes segregated bulk seed hoppers 110a, 110b, 110c, which are preferably supported by a toolbar of the planter or a cart drawn behind the planter. Each bulk seed hopper 110 is preferably in fluid communication with an associated entrainer 115. Each entrainer 115 is preferably in fluid communication with a blower or other pressure source P and is configured to distribute seeds received pneumatically from the bulk seed hoppers to a plurality of row units 190 via a plurality of pneumatic lines 120.

The entrainers 115 and pneumatic lines 120 are preferably configured to evenly distribute seeds between the row units 190. After the seeds pass through each line 120, seeds pass through a seed meter 140, which may comprise a seed meter such as that disclosed in Applicant’s co-pending International Patent Application No. PCT/US2012/030192, the disclosure of which is hereby incorporated herein in its entirety by reference. Each seed meter 140 preferably includes a seed pool 145 (see also FIG. 5) where seeds gather after being delivered to the meter 140. A seed disc 141 (FIG. 5) captures seeds from near the bottom of the seed pool 145 and deposits the seeds into a seed tube or seed conveyor. After entering the seed tube or conveyor, the seeds then pass by a seed sensor 155 (FIG. 1), which is preferably mounted to a seed tube of the row unit and which may comprise either an optical sensor or an electromagnetic sensor. After passing the seed sensor 155, the seeds are deposited into a trench opened by the row unit.

Turning to FIG. 13, an electrical system 600 for controlling the variety switch is illustrated schematically. The electrical system 600 preferably includes a monitor 610 having a graphical user interface 612, a memory 614 and a CPU 616. The monitor 610 is preferably in electrical communication with the seed sensors 155 of the variety selection system 100. The monitor 610 is preferably also in electrical communication with a global positioning (“GPS”) receiver 666 preferably mounted to the tractor and one or more speed sensors 668 preferably mounted to the tractor or the planter. The monitor 610 is preferably also in electrical communication with row clutches 670 and seed meter drives 672 configured to individually control each seed meter 140 or a group of seed meters. The monitor 610 is also preferably in electrical communication with an array of downforce sensors 662 (e.g., strain gauges) configured to measure the downforce applied to individual row units of the planter and

an array of ride quality sensors **664** (e.g., accelerometers) configured to generate a signal related to the ride quality of individual row units of the planter.

The monitor **610** is preferably in electrical communication with a seed pool level sensor **630** associated with each seed pool **145** at each row unit **190**. The monitor **610** is preferably in electrical communication with one or more seed pool actuators **650** associated with each seed pool **145** at each row unit **190**. In other embodiments, the monitor **610** is in electrical communication with a valve **640** configured to open or close an associated seed pool actuator **650**. Each valve **640** is preferably in fluid communication with a pressurized fluid source (e.g., an air compressor). In some embodiments described herein, the seed pool actuators **650** comprise actuators configured to close and open seed pool doors. In other embodiments, each seed pool actuator **650** comprises a servo motor configured to modify the position of a seed pool gate disposed at the end of a pneumatic line. In other embodiments, each seed pool actuator comprises a servo motor configured to modify the position of a seed pool at each row unit **190**. In other embodiments, each seed pool actuator comprises a solenoid configured to modify a position of a deflector key.

Pneumatic Line Apparatus

As illustrated in FIG. 1, a set of three pneumatic lines **120** (e.g., lines **120-1a**, **120-1b**, **120-1c**) in fluid communication with each of the three bulk seed hoppers **110a**, **110b**, **110c** preferably form a single segregated line **130** (e.g., segregated line **130-1**) extending from the entrainers **115** to one of the row units **190** (e.g., row unit **190-1**).

A first embodiment of the segregated line **130** is illustrated in FIG. 2, which is a cross-sectional view of the pneumatic line **120** as viewed along line 2-2 of FIG. 1. Each pneumatic line **120** preferably comprises a segregated, longitudinally extending inner volume of the segregated line **130**. Each pneumatic line **120** is preferably segregated from the other pneumatic lines by a partition **125**. In the embodiment of FIG. 2, the partition **125** forms radially symmetrical lines **120-1a**, **120-1b**, **120-1c** within the segregated line **130**. Seeds **60** travel through lines **120** in fluid communication with an associated bulk seed hopper **110** (e.g., seeds **60a** from seed hopper **110a** are travel through line **120-1a** within the segregated line **130-1**).

A second embodiment of the segregated line **130** is illustrated in the side view of FIG. 3 and in FIG. 4 which is a cross-sectional view of FIG. 3 as viewed along lines 4-4 of FIG. 3. As with the first embodiment, each pneumatic line **120** preferably comprises a segregated longitudinally extending inner volume of the segregated line **130**. Each pneumatic line **120** is preferably segregated from the other pneumatic lines by a partition **125** (e.g., the pneumatic lines **120-1a**, **120-1b** are separated by the partition **125-1ab** and the pneumatic lines **120-1b**, **120-1c** are separated by the partition **125-1bc**). Seeds **60** travel through lines **120** in fluid communication with an associated bulk seed hopper **110** (e.g., seeds **60a** from seed hopper **110a** are travel through line **120-1a** within the segregated line **130-1**).

Variety Selection Apparatus

As described above, the electrical system **600** preferably includes an actuator **650** or set of actuators **650** or actuator valves **640** configured to selectively place one of the pneumatic lines **120** in seed communication with the seed meter **140**.

Referring to the embodiment of FIG. 5 and as shown in FIG. 6, which schematically illustrates a partial cross-sectional view as viewed along lines 6-6 of FIG. 5, each pneumatic line **120** is in fluid communication with a segre-

gated seed pool **144** (e.g., the pneumatic line **120-1a** is in fluid communication with the segregated seed pool **144-1a**). Each segregated seed pool **144** is separated from a central seed pool **145** by a gate **142**. The set of actuators **650** comprises three actuators **143** configured to raise and lower the associated gates **142**. Each actuator **143** preferably comprises a pneumatic actuator spring-loaded into a refracted position such that each gate **142** is normally open unless the associated actuator **143** is extended. A pneumatic solenoid-operated on-off valve **640** is preferably in fluid communication with each actuator **143**. Each valve **640** is preferably in fluid communication with an air compressor supplying pressurized air to each valve **640**. When one of the actuators (e.g., actuator **143-1b**) is retracted to raise the associated gate (e.g., gate **142-1b**), seeds are allowed to fall from the seed pool disposed behind the gate (e.g., seed pool **144-1b**) into the central seed pool **145**. Seeds from the seed pool **145** are entrained on seed-carrying apertures in a seed disc **141** adjacent to the seed pool **145**. As the seed pool **145** empties, an optical sensor **630** disposed in a lower wall of the seed meter **140** is exposed to light (e.g., a light source inside the seed pool **145**) such that the optical sensor generates a signal corresponding to an empty seed pool.

In the embodiment of FIGS. 7A through 7C illustrating different views of one of the pneumatic lines **120**, a terminal portion of each pneumatic line **120** is selectively positioned adjacent the seed disc **141** to supply seed directly to the seed disc **141**. A vented cap **132-1** (FIGS. 7B-7C) selectively covers two of the segregated lines such that seeds are retained in the end of the pneumatic lines that are not used to supply seed to the seed disc **141**. The vented cap **132-1** comprises an end wall **133** having a plurality of apertures **137** therein and an opening **139**. The actuator **650** comprises a servo motor **134** configured to rotate the partition **125** relative to the vented cap **132-1** and the seed disc **141** in order to supply seed from a different one of the segregated lines to the seed disc **141**. For example, as the servo motor **134-1** rotates the partition **125-1** counterclockwise on the view of FIGS. 7B and 7C (or clockwise in the view of FIG. 7A), the line **120-1a** rotates behind the vented cap **132-1** and the line **120-1b** is exposed to the opening **139** in the vented cap **132-1** such that seeds are supplied from the line **120-1b** to the seed disc **141-1**.

In the embodiment of FIG. 8, the segregated line **130** terminates above a conveyor **149** having two seed pools **145-r**, **145-f**. A first actuator **650-1** preferably comprises a servo motor **134-1** configured to rotate a vented cap **132-1** relative to the terminal end of the segregated line **130** in order to selectively open one of the pneumatic lines **120** (e.g., in FIG. 8, the cap **132-1** is positioned to open the pneumatic line **120-1b**). A second actuator **650-2** preferably comprises a servo motor **136-1** configured to adjust a position of the conveyor **149** in order to modify the position of the seed pools **145-r**, **145-f** relative to the seed disc **141-1**. In a first position, the seed pool **145-f** is positioned adjacent to the seed disc **141-1** to supply seed to the seed disc. In the first position, seeds supplied from the segregated line **130-1** are deposited into the seed pool **145-r**. In a second position, the seed pool **145-r** is positioned adjacent to the seed disc **141-1** to supply seed to the seed disc.

In the embodiment of FIG. 9, three segregated seed pools **144** are in fluid communication with pneumatic lines **120** for receiving seed from the bulk seed hoppers **110** (e.g., seed pool **144-1c** is in fluid communication with pneumatic line **120-1c**). Each seed pool **145** is adjacent to and in seed communication with concentrically arranged seed aperture arrays **170** (e.g., the seed pool **144-1a** is adjacent to and in

5

seed communication with the seed aperture array **170-1c**). An actuator **650** preferably comprises a linear actuator **150** configured to modify a position of a key **152**. The key **152** is preferably configured to selectively deflect two of the three seed aperture arrays **170** such that seeds fall back into the seed pool **145** from which seeds are drawn by the associated aperture arrays **170**. As illustrated in FIG. **10**, the key **152** preferably includes two deflectors **154**, **158** each having a width $2W_s$ (where W_s is the transverse width of each seed aperture array **170** as illustrated in FIG. **9**) separated by an opening **156** having a width W_s . It should be appreciated that this configuration of the key **152** allows positioning of the key to selectively deflect seeds from any two of the three seed aperture arrays **170** while allowing seeds on the other seed aperture array to be transferred past the key **152** and deposited by the disc. For example, in FIG. **9** the deflector **154** deflects seeds from seed aperture arrays **170-1c** and **170-1b** into the seed pools **144-1c** and **144-1b**, respectively, while seeds are carried by seed aperture array **170-1a** through the opening **156** and deposited by the disc **141**.

In the embodiment of FIG. **11**, three segregated seed pools **144** are in fluid communication with pneumatic lines **120** for receiving seed from the bulk seed hoppers **110** (e.g., seed pool **144-1c** is in fluid communication with pneumatic line **120-1c**). Each seed pool **145** is adjacent to and in seed communication with concentrically arranged seed aperture arrays **170** (e.g., the seed pool **144-1c** is adjacent to and in seed communication with the seed aperture array **170-1c**). An actuator **650** preferably comprises a linear actuator **160** configured to modify a position of a roller key **162**. The roller key **162** is preferably configured to selectively cut off the vacuum from two of the three seed aperture arrays **170** such that seeds fall back into the seed pool **145** from which seeds are drawn by the associated aperture arrays **170**. As illustrated in FIG. **12**, the roller key **162** preferably includes two rollers **164**, **168** each having a width $2W_s$ (where W_s is the transverse width of each seed aperture array **170** as illustrated in FIG. **11**) separated by an opening **166** having a width W_s . It should be appreciated that this configuration of the roller key **162** allows positioning of the roller key **162** to selectively cut off vacuum at any two of the three seed aperture arrays **170** while allowing seeds in the other seed aperture array to be transferred and deposited by the disc. For example, in FIG. **11** the roller **164** cuts off vacuum from seed aperture arrays **170-1a** and **170-1b** allowing seeds to fall back into the seed pools **144-1a** and **144-1b**, respectively, while seeds are carried by seed aperture array **170-1c** and deposited by the disc **141**.

In the embodiment illustrated in FIGS. **16A** and **16B** (where **16B** is an enlarged partial side elevation view of FIG. **16A**), a seed side housing **135** of the seed meter **140** includes three seed pools **145** laterally separated by brushes **196**. Each brush **196** is preferably disposed to be in contact with the seed disc **141** when the seed side housing **135** is mounted to the seed meter **140**. Each seed pool **145** is preferably in seed communication with an associated pneumatic line **120**. As the seed disc **141** rotates in the direction **S** past the seeds in the seed pools **145**, seeds are entrained on the seed aperture arrays **170** and drawn upward out of the seed pools **145**. After the seeds exit the seed pools **145**, seeds are drawn past the singulators **195**; the singulators **195** preferably comprise singulators including multiple co-planar lobes such as those disclosed in Applicant's co-pending International Patent Application No. PCT/US2012/030192, the disclosure of which is hereby incorporated herein in its entirety by reference. The singulators **195** are preferably

6

supported in a spring-loaded fashion by the seed side housing **135** such that the singulator lobes are preferably axially biased against the surface of the seed disc **141**. Each singulator **195** is preferably radially biased against an annular shoulder (not shown) provided in the seed disc **141** such that the singulators **195** "float" radially with radial displacement of the seed disc **141**. As seeds are drawn past singulators **195**, multiple seeds (e.g., doubles or triples) entrained on the seed apertures are stripped from the surface of the disc and fall back into the seed pool **145**. It should be appreciated that the singulators **195** are preferably disposed above the associated seed pools such that each seed falls into the seed pool from which it originated after being removed by the singulator **195**.

The seed aperture array **170-1a** is preferably disposed at a radial distance D_a from the axial center of the seed disc **141**. The distance D_a is preferably approximately six (6) inches. The seed aperture array **170-1b** is preferably disposed at a radial distance $D_a + D_b$ from the axial center of the seed disc **141**. The distance D_b is preferably between 2 (two) and 3 (three) inches. The seed aperture array **170-1c** is preferably disposed at a radial distance $D_a + D_b + D_c$ from the axial center of the seed disc **141**. The distance D_c is preferably between 2 (two) and 3 (three) inches.

After passing through the singulators **195**, seeds are then selectively removed from the seed apertures by a key **800**. The key **800** is preferably selectively rotated by a solenoid **150**. It should be appreciated that the solenoid **150** comprises an actuator **650** configured to select an active seed pool **145**. Referring to FIGS. **17A-17C**, the key **800** preferably includes deflectors disposed to selectively deflect seeds from the surface of the seed disc **141**. Deflectors **832**, **834** are disposed to deflect seeds from the seed aperture arrays **170-1b**, **170-1c** respectively when the key **800** is oriented such that the deflectors **832**, **834** extend toward the seed disc **141**, but the key **800** allows seeds on the seed aperture array **170-1a** to pass the deflector key **800** undeflected when the key is in that position. As the key **800** is rotated, e.g., in 90 degree intervals, the deflectors **812**, **814** and **822**, **824** similarly selectively deflect seeds from the surface of the seed disc **141**. The solenoid **150** preferably has first, second and third positions in which the key **800** is rotated by increments of 90 degrees. Each deflector preferably has a width W_s at least as wide as the width W_s of the seed apertures on the disc **141** such that seeds are effectively deflected from the apertures by the deflectors; likewise, a gap between the deflectors also preferably has a width W_s such that seeds are allowed to pass between the deflectors. The solenoid preferably rotates between the first, second and third positions based upon the voltage applied to the solenoid; for example, in some embodiments 1 volt corresponds to the first position, 0 volts corresponds to the second position, and -1 volt corresponds to the third position.

After seeds are deflected from the seed disc **141** by the key **800**, they preferably fall back into the seed pool **145** from which each seed originated. Thus the key **800** is preferably disposed such that each deflector is positioned vertically above the seed pool **145** corresponding to the seed aperture array **170** drawing seeds from the seed pool to the deflector.

A vacuum seal (not shown) creates a vacuum on the vacuum side of the seed disc **141** (i.e., the reverse side of the seed side of the seed disc illustrated in FIG. **16A**) such that seeds are entrained on the seed aperture arrays **170** by the vacuum created on the vacuum side. The vacuum seal preferably creates a vacuum in a region beginning at approximately 7 o'clock (as viewed in FIG. **16A**) such that

seeds are entrained at the seed pools **145**. The vacuum seal preferably terminates along a substantially vertical border **180**. The border **180** is preferably between 0 and 3 inches forward of the center of the seed disc **141**); in some embodiments the upper end of the border **180** is located between 12 o'clock and 1 o'clock as viewed in FIG. **16A**. Because the vacuum seal terminates adjacent a portion of the seed aperture arrays **170** at which the seeds have a forward horizontal velocity, seeds released from the disc **141** after the vacuum seal terminates travel a forward distance while falling from the disc (e.g., along an arcuate path such as path **182** illustrated in FIG. **16A**). However, the horizontal velocity of seeds on the seed aperture arrays **170** decreases with the distance of the seed aperture arrays **170** from the center of the disc such that the forward distance traveled by the seeds decrease with the distance of the seed aperture arrays from the disc; e.g., seeds falling from the seed aperture array **170-1c** travel a smaller forward distance than seeds released from the seed aperture array **170-1a**. Additionally, because seeds on the outer seed aperture arrays **170-1b**, **170-1c** are released at the same fore-aft position as the inner seed aperture array **170-1a**, the width of a fall zone **186** is smaller than if the border **180** was angled forward or extended radially from the center of the seed disc **141**. The width of the fall zone **186** is preferably smaller than the width of an opening in the upper end of a seed tube **185** disposed to receive seeds falling from the disc. In other embodiments the vacuum seal terminates along a border that is angled rearwardly such that an upper end of the border is rearward of a lower end of the border; in such embodiments the width of the fall zone **186** is even smaller than that illustrated in FIG. **16A**.

In some embodiments, rather than free-falling from the seed disc into the seed tube **185**, seeds fall into the flights of a flighted conveyor belt disposed to capture the seeds from any of the aperture arrays and to deposit the seeds captured from the aperture arrays into the seed tube. The flighted conveyor belt may be similar to that described in U.S. Provisional Application No. 61/923,426, incorporated herein in its entirety by reference. In other embodiments, the flighted conveyor belt is configured to deposit seeds directly into the trench. The flighted conveyor belt is preferably driven at a speed directly related to the rotational speed of the seed meter. In some embodiments the flighted conveyor belt is driven by the same motor used to drive the seed disc or driven by a gear driven by rotation of the seed disc. In other embodiments the flighted conveyor belt is driven by a separate motor.

In another embodiment of the system **100**, each set of pneumatic lines **120** of the system **100** are in communication with an input switching system and variety switch for switching the variety of seed supplied to the seed meter **140**, such as are disclosed in U.S. Provisional Application No. 61/929,665, which is incorporated herein in its entirety by reference.

Variety Selection and Mapping Processes

A process **700** for selecting and mapping seed varieties is illustrated in FIG. **14**. It should be appreciated that the process **700** is adapted for metering apparatus having a central seed pool (e.g., the central seed pool **145-1** in the seed meter **140** of FIG. **5**). At step **705**, the monitor **610** preferably selects a seed pool actuator position (e.g., extends the actuators **143-1a** and **143-1c** and retracts the actuator **143-1b** to allow seeds from seed pool **144-1b** to enter the seed pool **145-1**). At step **710**, the monitor **610** preferably estimates a seed pool count (e.g., by determining whether the signal generated by the seed pool level sensor **630**

corresponds to a nearly empty seed pool). For example, if the seed pool level sensor **630** indicates that light is being received by the seed pool level sensor, the monitor **610** preferably assumes a predetermined number of seeds (e.g., 30 seeds) remain in the seed pool **145**. At step **715**, the monitor **610** preferably determines the number of seeds to a variety selection event based on a prescription map stored in the memory of the monitor **610**, e.g., using the processes disclosed in Applicant's U.S. Provisional Application No. 61/745,315, the disclosure of which is hereby incorporated herein in its entirety by reference. At step **720**, the monitor **610** preferably compares the seed pool count to the number of seeds to a variety selection event. At step **725**, the monitor **610** preferably modifies a seed pool actuator position when the seed pool count equals the number of seeds to a variety selection event. For example, when the number of seeds to a boundary between a portion of the field to be planted with seeds from bulk seed hopper **110b** and **110a** is equal to the number of seeds in the seed pool **145-1**, the monitor **610** preferably retracts the actuator **143-1a** and extends the actuator **143-1b** in order to allow seeds from the seed pool **144-1a** to enter the seed pool **145-1**. At step **730**, the monitor **610** preferably generates and displays an as-planted variety map in which distance traveled by the implement during the actuator position modification is indicated by a "blended zone" in which both seeds from bulk seed hoppers **110a** and **110b** may have been planted.

A process **750** for selecting and mapping seed varieties is illustrated in **15**. It should be appreciated that the process **750** is adapted for metering apparatus having multiple seed pools and no central seed pool, such as the seed meter embodiment of FIGS. **7A-7C**. At step **755**, the monitor **610** selects a seed pool actuator position (e.g., moves the seed pool relative to the disc in the embodiment of FIG. **8** or rotates the servo motor **134** in the embodiments of FIGS. **7A-7C** in order to place a different pneumatic line **120** in seed communication with the seed disc **141**). At step **760**, the monitor **610** compares a position of the implement (as reported by the GPS receiver **666**) to a boundary between two varieties on a variety prescription map stored in the memory of the monitor **610**. At step **765**, the monitor **610** preferably modifies a seed pool actuator position when the implement position crosses a variety boundary on the prescription map. For example, the monitor **610** preferably commands the servo motor **134** to rotate in the embodiments of FIGS. **7A-7C** in order to place a different pneumatic line **120** in seed communication with the seed disc **141**. At step **770**, the monitor **610** preferably generates and displays an as-planted variety map in which the location of the actuator position modification is indicated by a border between seed types stored in bulk seed hoppers **110a** and **110b**.

A process **900** for selecting and mapping seed varieties is illustrated in FIG. **18**. It should be appreciated that the process **900** is adapted for metering apparatus having a multiple seed pools in seed communication with multiple seed arrays from which seeds are selectively deflected from the seed disc by a deflector key, e.g., the embodiments of FIGS. **9** and **11** (and associated embodiments of the keys **152**, **162**, respectively of FIGS. **10** and **12**) or the embodiments of FIGS. **16A-16B** (and associated embodiment of the key **800** in FIGS. **17A-17C**). At step **905**, the monitor **610** preferably selects a first position of the deflector key **800**, e.g. by modifying the position of the solenoid **150**. The selected position of the deflector key **800** preferably allows one and only one of the three seed aperture arrays **170** (e.g., seed aperture array **170-1a**) to carry seeds from the associated seed pool **145** for deposition into the seed tube **185**

while the deflectors on the deflector key deflect seeds from the other two seed aperture arrays (e.g., seed aperture arrays **170-1b** and **170-1c**). At step **910**, the monitor **610** preferably compares a position of the planter, e.g., as reported by the GPS receiver **666**, to a variety selection boundary on a variety map stored in the memory **614** of the monitor **610**. Once a variety selection boundary has been crossed, at step **920** the monitor **610** preferably selects a second position of the deflector key **800**, e.g. by modifying the position of the solenoid **150** to rotate the deflector key **800** through 90 degree increments about a longitudinal axis of the deflector key. The selected second position of the deflector key **800** preferably allows one and only one of the three seed aperture arrays **170** (e.g., seed aperture array **170-1b**) to carry seeds from the associated seed pool **145** for deposition into the seed tube **185** while the deflectors on the deflector key deflect seeds from the other two seed aperture arrays (e.g., seed aperture arrays **170-1a** and **170-1c**). At step **925**, the monitor **610** preferably commands the seed meter drive **672** to rotate at a new rate R' in revolutions per minute (rpm) corresponding to the desired application rate, the implement speed, and the number of seed apertures in the activated seed aperture array **170**. For example, where the deflector key **800** is rotated to deactivate a seed pool array **170-1a** having N_a seeds and to activate a seed pool array **170-1b** having a N_b seeds, assuming a constant desired application rate (e.g. 30,000 seeds per acre) and constant implement speed as reported by the GPS receiver **666** or the speed sensor **668** (e.g., 5 miles per hour), the monitor **610** preferably modifies the rate of seed meter drive rotation R from R to R' according to the equation:

$$R' (rpm) = R \times \frac{N_b}{N_a}$$

At step **930**, the monitor **610** preferably generates spatial data reflecting the as-planted seed variety (e.g., by recording a seed type associated with the seed pools from which the meter **140** allows seeds to be planted prior to and after the variety boundary) and displays an as-applied variety map (e.g., by displaying a map having regions reflecting the seed types planted before and after the variety boundary).

The foregoing description is presented to enable one of ordinary skill in the art to make and use the invention and is provided in the context of a patent application and its requirements. Various modifications to the preferred embodiment of the apparatus, and the general principles and features of the system and methods described herein will be readily apparent to those of skill in the art. Thus, the present invention is not to be limited to the embodiments of the apparatus, system and methods described above and illustrated in the drawing figures, but is to be accorded the widest scope consistent with the spirit and scope of the appended claims.

The invention claimed is:

1. A system for selecting an agricultural input, comprising:
 - a first input source of a first seed;
 - a second input source of a second seed;
 - a meter having a seed disc, said meter in communication with said first input source of said first seed and said second input source of said second seed;
 - a selection apparatus which constrains said meter to deposit only said first seed or said second seed at one time;
 - processing circuitry in electrical communication with said selection apparatus, said processing circuitry configured to send a command signal to said selection apparatus in order to modify a configuration of said selection apparatus from a first configuration to a second configuration, wherein in said first configuration said meter deposits said first seed, and wherein in said second configuration said meter deposits said second seed;
 - wherein said selection apparatus includes:
 - a first segregated pool of said first seed;
 - a second segregated pool of said second seed;
 - wherein said first seed pool and said second seed pool each comprise terminal portions of segregated pneumatic lines;
 - a vented cap disposed between said terminal portions of said segregated pneumatic lines and said seed disc, said vented cap having an opening therein; and
 - an actuator responsive to said processing circuitry, wherein said actuator rotates said vented cap relative to said terminal portions of said segregated pneumatic lines, such that said opening in said vented cap is selectively positionable between a first position and a second position, wherein in said first position said first seed in said first segregated pool is in communication with said seed disc, and said second seed in said second segregated pool is out of communication with said seed disc, and wherein in said second position said second seed in said second segregated pool is in communication with said seed disc, and said first seed in said first segregated pool is out of communication with said seed disc, and wherein, in both said first position and said second position, air in said segregated pneumatic lines escapes through said vented cap.
2. The system of claim **1**, wherein said segregated pneumatic lines comprises a segregated, longitudinally extending inner volume of a single segregated line.
3. The system of claim **1**, further comprising:
 - a global positioning receiver in communication with said processing circuitry, wherein said processing circuitry includes a prescription map stored in memory, wherein said processing circuitry times said command signal based on said prescription map.
4. The system of claim **1**, wherein said vented cap includes a plurality of apertures.

* * * * *