

US009967151B2

(12) **United States Patent**  
**Hall et al.**

(10) **Patent No.:** **US 9,967,151 B2**  
(45) **Date of Patent:** **May 8, 2018**

(54) **SECURE REMOTE ACTUATION SYSTEM**

(71) Applicant: **David R. Hall**, Provo, UT (US)

(72) Inventors: **David R. Hall**, Provo, UT (US); **Mark Hall**, Springville, UT (US); **Craig Boswell**, Draper, UT (US)

(\* ) Notice: Subject to any disclaimer, the term of this patent is extended or adjusted under 35 U.S.C. 154(b) by 218 days.

(21) Appl. No.: **14/323,618**

(22) Filed: **Jul. 3, 2014**

(65) **Prior Publication Data**

US 2016/0004230 A1 Jan. 7, 2016

**Related U.S. Application Data**

(63) Continuation-in-part of application No. 14/323,549, filed on Jul. 3, 2014, now Pat. No. 9,712,335.

(60) Provisional application No. 61/941,130, filed on Feb. 18, 2014, provisional application No. 61/971,978, filed on Mar. 28, 2014, provisional application No. 61/979,935, filed on Apr. 15, 2014, provisional application No. 61/985,399, filed on Apr. 28, 2014,  
(Continued)

(51) **Int. Cl.**

**H04L 12/24** (2006.01)  
**G05B 15/02** (2006.01)  
**G06F 3/0484** (2013.01)  
**G08B 25/00** (2006.01)  
**G08B 25/10** (2006.01)  
**G08C 17/02** (2006.01)  
**H04L 12/28** (2006.01)  
**H04N 7/18** (2006.01)  
**H04L 29/08** (2006.01)  
**H04M 1/725** (2006.01)  
**H04W 12/08** (2009.01)  
**H04W 76/04** (2009.01)

**H04M 11/00** (2006.01)

**H04W 4/02** (2018.01)

**H04W 24/04** (2009.01)

(52) **U.S. Cl.**

CPC ..... **H04L 41/22** (2013.01); **G05B 15/02** (2013.01); **G06F 3/04847** (2013.01); **G08B 25/008** (2013.01); **G08B 25/10** (2013.01); **G08C 17/02** (2013.01); **H04L 12/2803** (2013.01); **H04L 12/2816** (2013.01); **H04L 41/082** (2013.01); **H04L 41/28** (2013.01); **H04L 67/02** (2013.01); **H04L 67/1097** (2013.01); **H04M 1/72533** (2013.01); **H04M 11/007** (2013.01); **H04N 7/18** (2013.01); **H04W 4/023** (2013.01); **H04W 12/08** (2013.01); **H04W 24/04** (2013.01); **H04W 76/046** (2013.01); **H04W 76/27** (2018.02)

(58) **Field of Classification Search**

CPC ... **G07C 9/00182**; **H04W 76/27**; **H04W 12/08**  
USPC ..... **340/5.2**  
See application file for complete search history.

(56) **References Cited**

**U.S. PATENT DOCUMENTS**

4,614,945 A 9/1986 Brunius et al.  
5,576,701 A 11/1996 Heitschel et al.  
(Continued)

*Primary Examiner* — Vernal Brown

(57) **ABSTRACT**

A secure remote actuation system may comprise a remote input receptor and a central signal switch. The remote input receptor may comprise a user interface for receiving user inputs from a user. The central signal switch may comprise acceptable inputs. The central signal switch may further comprise a microcontroller for obtaining and comparing the user inputs to the acceptable inputs. In the present invention, the microcontroller obtains the user inputs from the remote input receptor while the user is using the user interface.

**20 Claims, 4 Drawing Sheets**

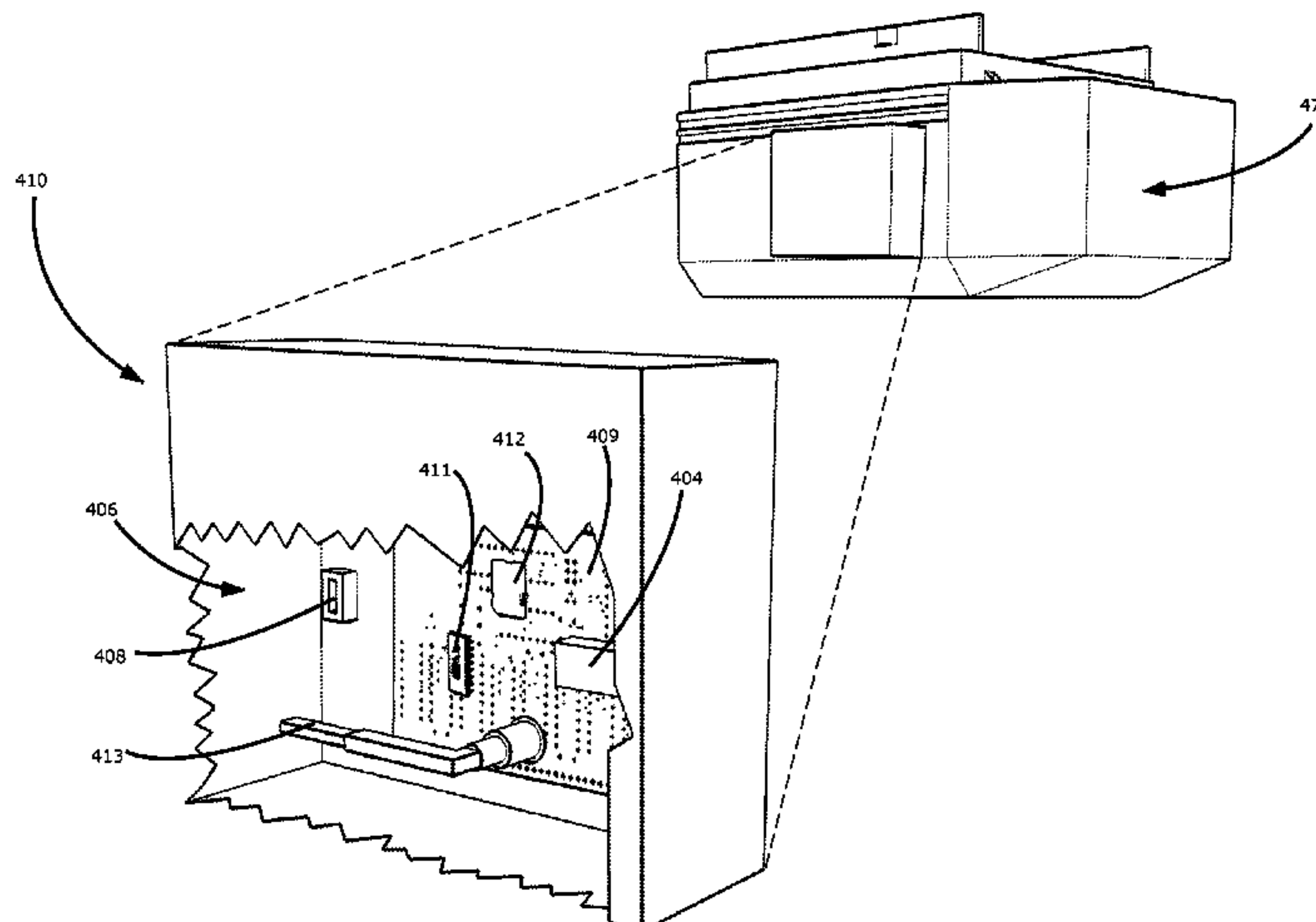

**Related U.S. Application Data**

provisional application No. 61/975,644, filed on Apr. 4, 2014, provisional application No. 61/977,070, filed on Apr. 8, 2014.

(56) **References Cited**

U.S. PATENT DOCUMENTS

5,872,513	A	2/1999	Fitzgibbon et al.	
5,898,397	A	4/1999	Murray	
6,400,968	B1 *	6/2002	White .....	G08C 17/02 455/127.1
6,529,230	B1 *	3/2003	Chong .....	G08B 25/14 348/14.01
7,552,467	B2	6/2009	Lindsay	
8,326,424	B2	12/2012	Bange et al.	
8,331,544	B2	12/2012	Kraus et al.	
8,538,341	B2	9/2013	Rousseau	
8,639,339	B2	1/2014	Bange et al.	
2002/0014954	A1 *	2/2002	Fitzgibbon .....	G07C 9/00182 340/5.64
2006/0220834	A1 *	10/2006	Maeng .....	G08B 21/24 340/539.1
2013/0027181	A1	1/2013	King	
2013/0229132	A1 *	9/2013	Fong .....	G08C 19/00 315/312

\* cited by examiner

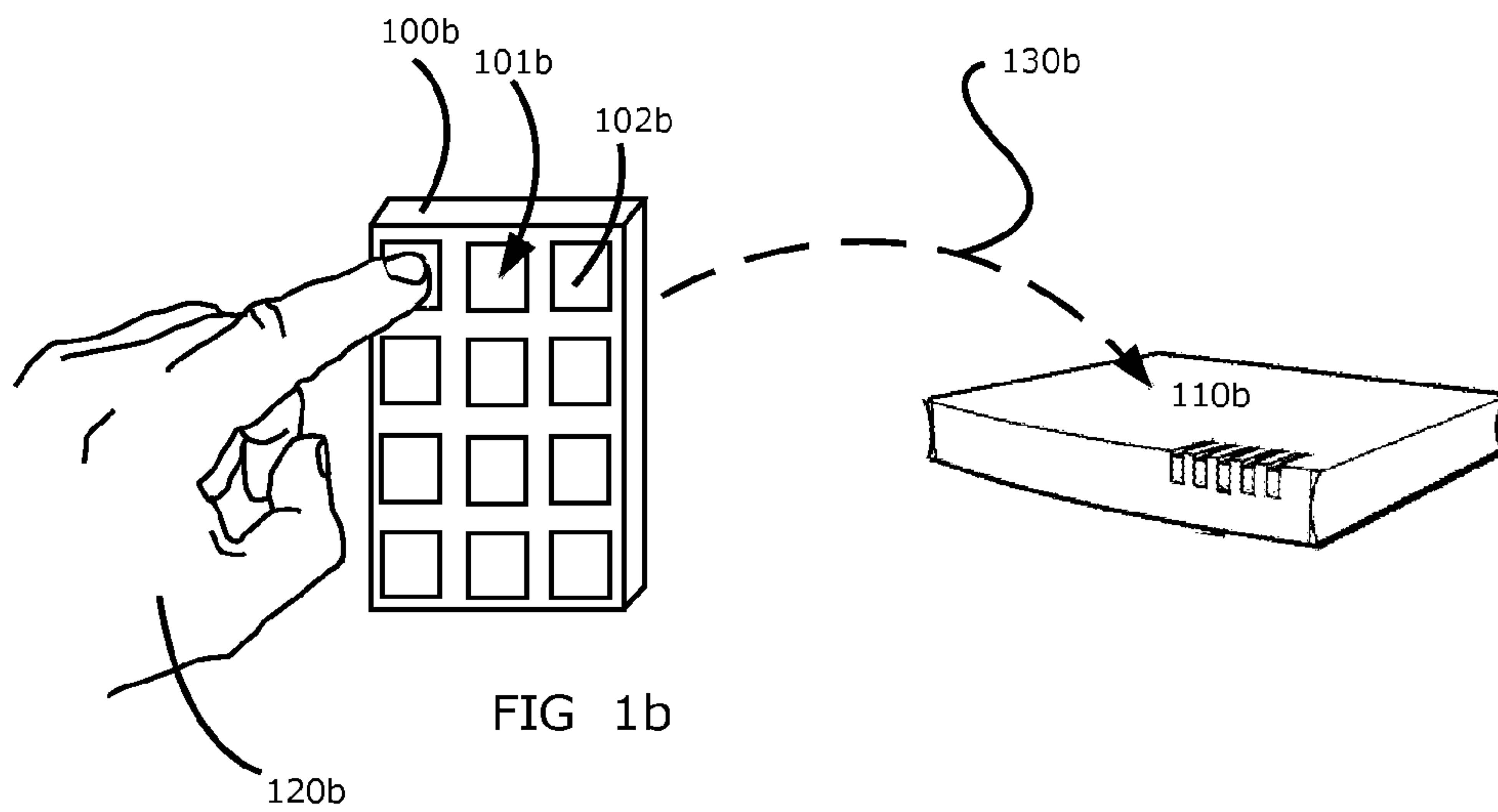
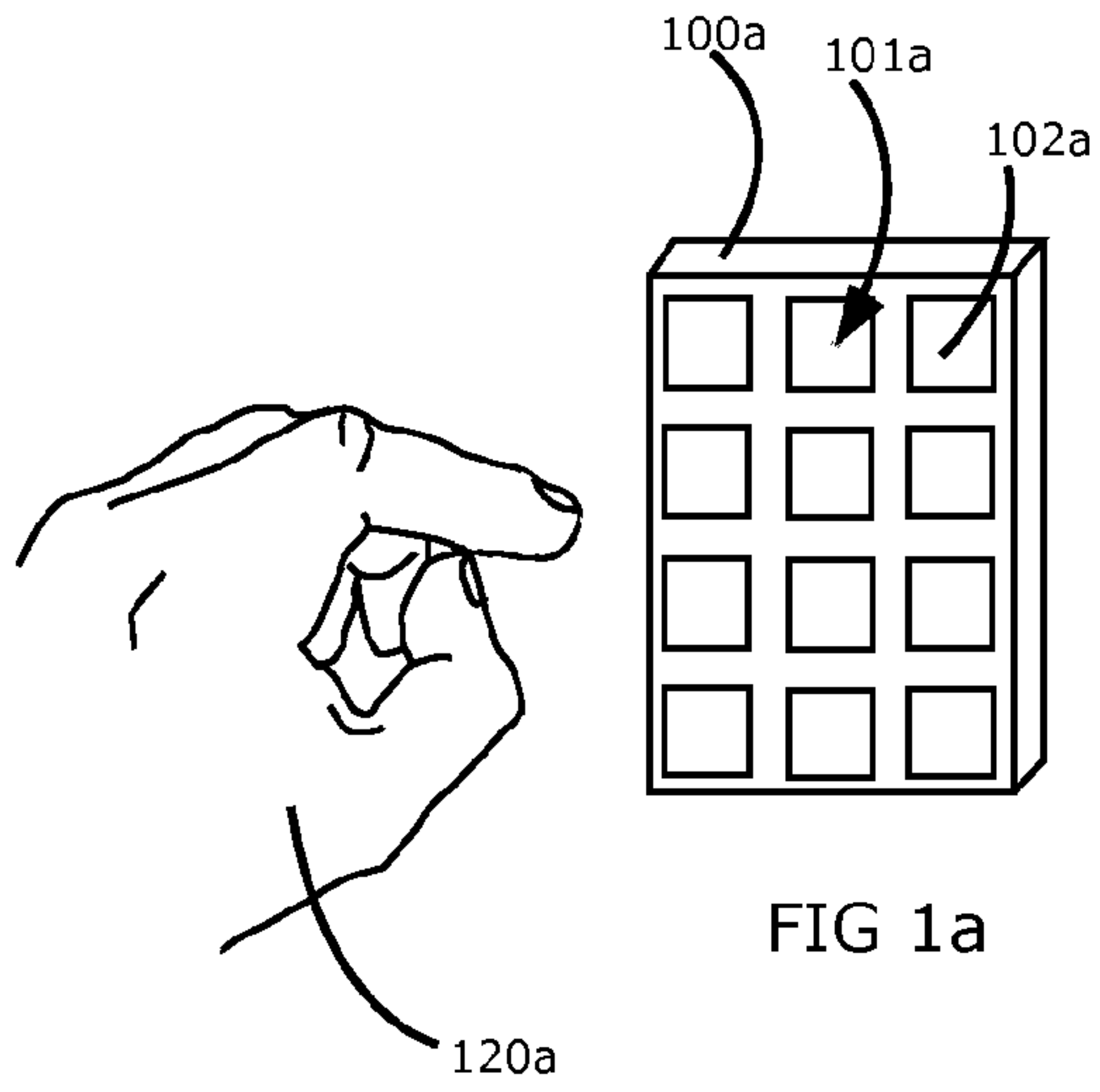

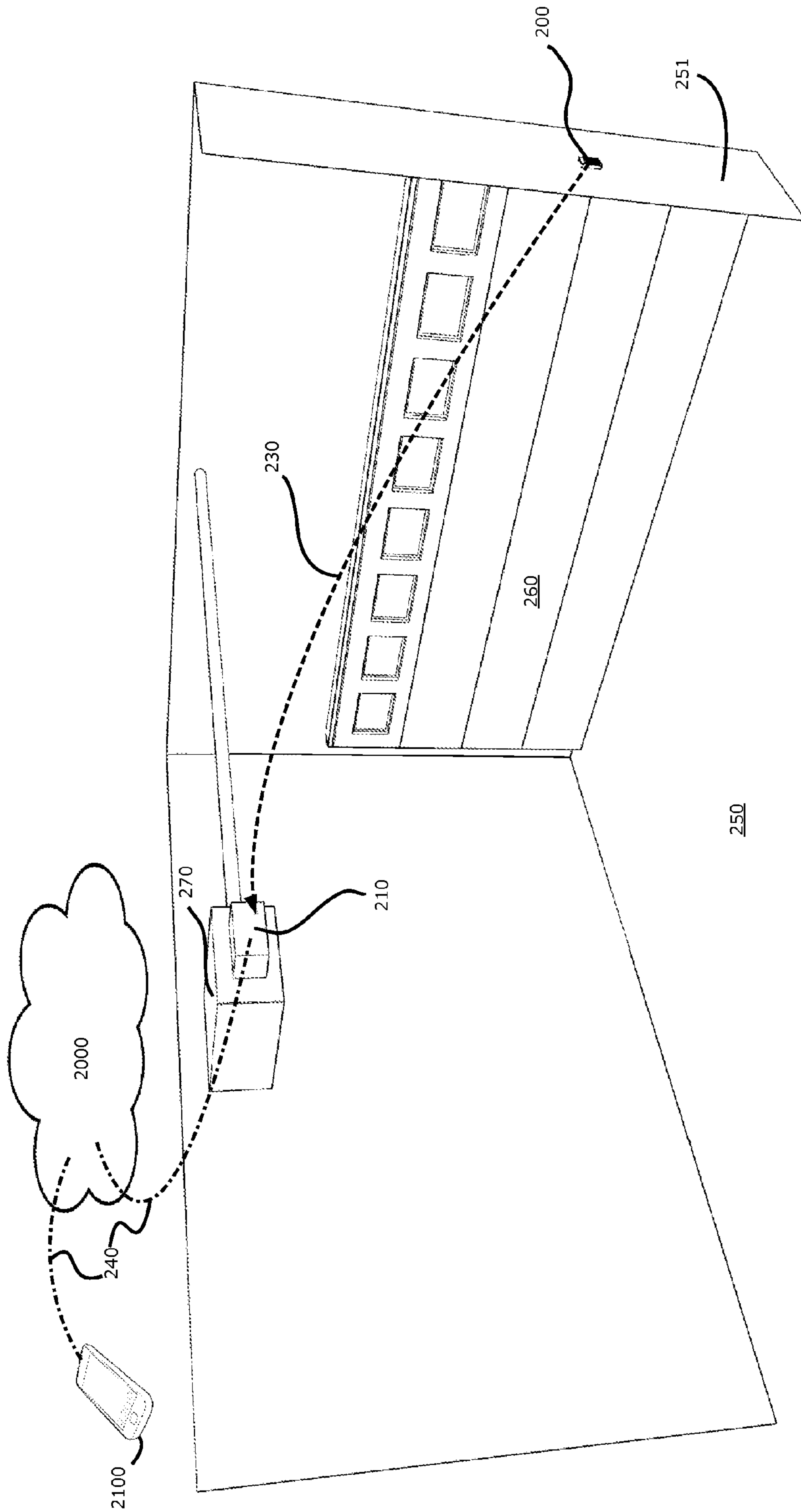

FIG 2

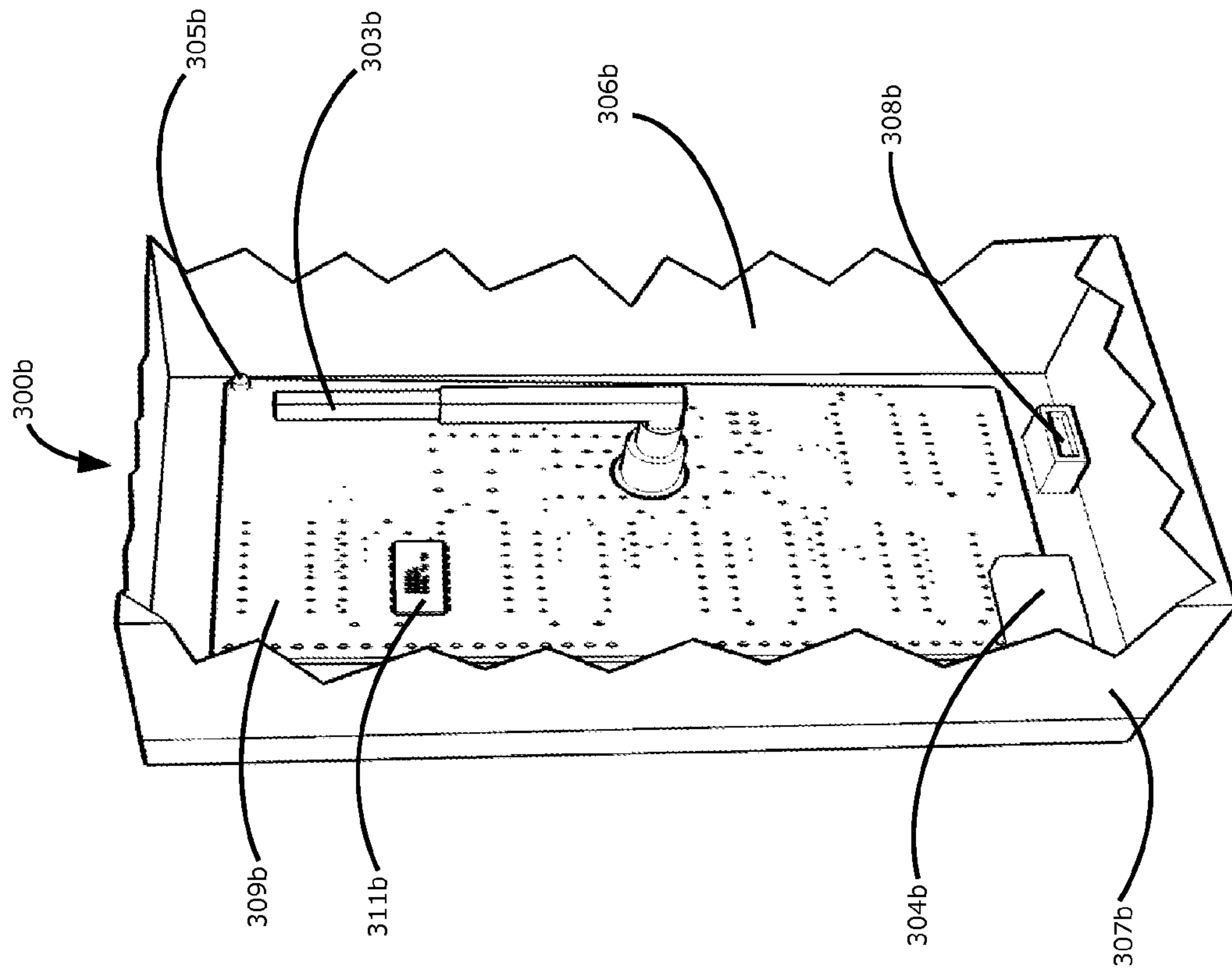

FIG 3b

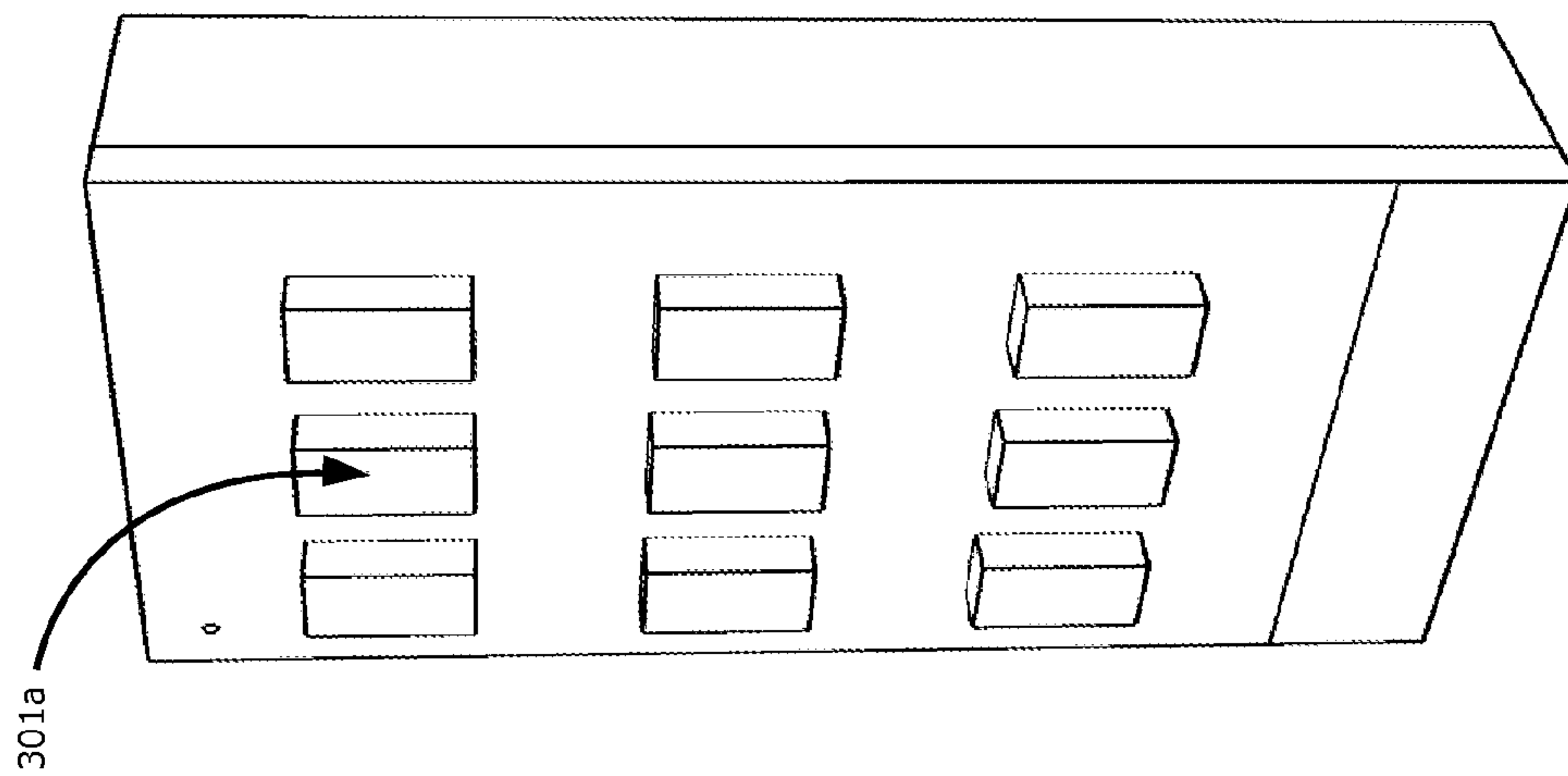

FIG 3a



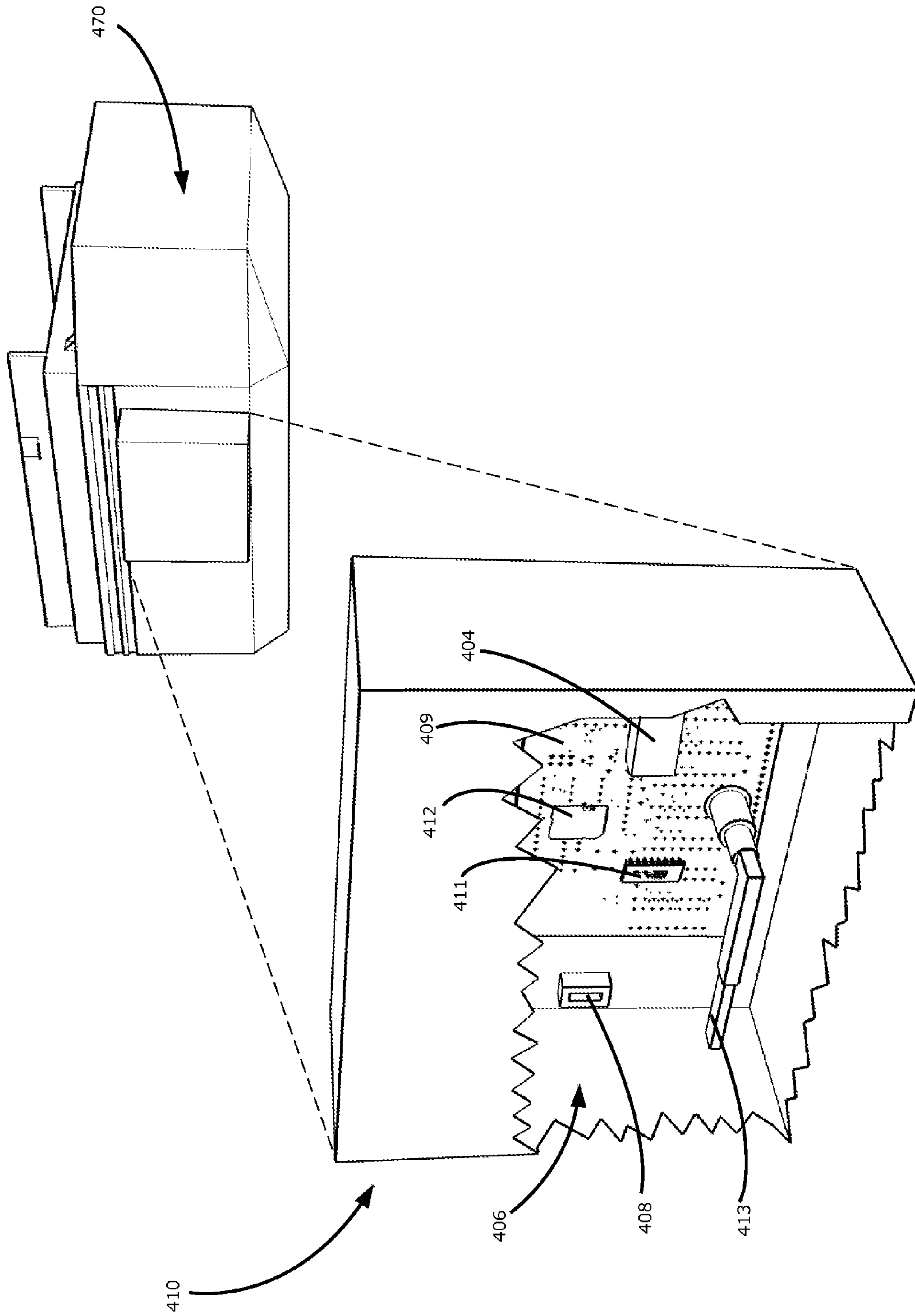

FIG 4

## SECURE REMOTE ACTUATION SYSTEM

## CROSS REFERENCE TO RELATED APPLICATIONS

This application is a continuation-in-part of U.S. patent Ser. No. 14/323,549 filed on Jul. 3, 2014 and entitled "Secure Remote Actuation System" which is incorporated by reference herein for all that it contains.

## BACKGROUND OF THE INVENTION

The present invention relates generally to remote actuation systems comprising devices capable of performing remote operations. Examples of typical remote actuation systems include thermostats, which may control heating and cooling devices from a remote location, and garage door openers, which may provide remote access to secured areas. The remote portions of such devices commonly require a portable power source, such as a battery or photovoltaic cell. It is also typical of such devices to comprise communications means, such as a radio frequency transceiver, to receive and/or relay information.

For example U.S. Pat. No. 8,331,544 to Kraus et al., which is incorporated herein for all that it discloses, describes a system that remotely operates a door lock. The door lock may be powered by a battery and be configured to send and receive radio frequency signals as part of a mesh network. In such a mesh network, each connected device acts as a communication node that can send and receive packets of information to any other device in the network. The door lock may further comprise a memory module where individual user codes are stored and a logic module to compare user codes to input codes at the door to allow access decisions to be made at the door without transmissions.

Such systems typically require continuing communications over a network that may cause rapid consumption of power. Thus, various attempts have been made to conserve power in such systems. For example, U.S. Pat. No. 4,614,945 to Brunius, et al., which is incorporated herein for all that it discloses, describes communicating information between a plurality of instrument monitoring units to a remotely located data collection unit. The monitoring units are radio frequency transponder circuits that are operatively connected to one or more instruments whose parameters are being monitored. The transponders continuously monitor one or more parameters of the instrument(s) with which they are associated. The transponders collect and accumulate parameter information and/or data from their associated instruments and continually listen for a "wake-up" signal from an interrogate receiver/data collection unit.

Despite these advances in the art, improved means of conserving power in remote actuation systems is desirable.

## BRIEF SUMMARY OF THE INVENTION

A secure remote actuation system may comprise a remote input receptor and a central signal switch. The remote input receptor may comprise a user interface for receiving user inputs from a user. The central signal switch may comprise one or more acceptable inputs. The central signal switch may further comprise a microcontroller for obtaining and comparing the user inputs to the acceptable inputs. In the present invention, the microcontroller obtains the user inputs from the remote input receptor while the user is using the user interface.

The remote input receptor may also comprise a communication device, such as a radio frequency transceiver, for sending the user inputs to the central signal switch and/or a portable power source, such as a battery or solar panel.

The remote input receptor may be capable of executing a low power function after the user inputs are received from the user, wherein power is cut from unneeded subsystems and reduced in others until reactivated. The remote input receptor may exit the low power function when the user begins to use the user interface again.

The remote input receptor may additionally comprise a surveillance device to detect the user, such as a camera, a microphone, a proximity sensor, or a combination thereof. The remote input receptor may then exit the low power function when the surveillance device detects the user.

The user interface may comprise buttons, a visual display, capacitive sensors, a microphone, a vibration recognition module, a proximity sensor, a fingerprint scanner, a retina scanner, a voice recognition module, or a combination thereof as a means for receiving acceptable inputs from a user.

The remote input receptor and/or the central signal switch may comprise data connection ports. Such data connection ports may be disposed in an interior of the remote input receptor or the central signal switch.

The central signal switch may be connected to a network for sending and receiving acceptable inputs. The network may comprise a software application allowing for an individual to control the acceptable inputs at said central signal switch. For example, the software application may allow the individual to edit, add, or delete the acceptable inputs from the central signal switch, change parameters, change personal settings, alter system firmware, and/or conduct diagnoses.

The central signal switch may further comprise an internal memory unit for storing the acceptable inputs, the user inputs, a history of user inputs, input parameters and/or access parameters. Additionally, the central signal switch may be connected to and capable of controlling various actionable devices, such as a thermostat, a television, an automated window, automated blinds, a ventilation system, a sprinkler system, a lighting element, an indoor positioning system, an access control device, or a combination thereof. The access control device may be an electromechanical locking mechanism or a garage door opener that may secure an enclosed area, room, building, or delivery box.

## BRIEF DESCRIPTION OF THE DRAWINGS

FIGS. 1a and 1b show perspective views of an embodiment of a remote input receptor comprising a user interface, a portion of a user, and a signal switch.

FIG. 2 shows a perspective view of elements of an embodiment of a remote secure access system associated with an enclosed area.

FIG. 3a shows a perspective view of an embodiment of a remote input receptor.

FIG. 3b shows a partially cutaway perspective view of an interior of the remote input receptor shown in FIG. 3a comprising a plurality of components supported by a printed circuit board disposed therein.

FIG. 4 shows a partially cutaway perspective view of an interior of an embodiment of a central signal switch comprising a plurality of components supported by a printed circuit board disposed therein.



DETAILED DESCRIPTION OF THE  
INVENTION

FIG. 1*a* shows an embodiment of an input receptor **100a**, a central signal switch **110a**, and a user **120a**. The input receptor **100a** may comprise a user interface **101a** for receiving one or more user inputs from the user **120a**. The user interface **101a** shown comprises one or more buttons **102a**. Such user interfaces may also comprise a visual display, one or more capacitive sensors, a microphone, a vibration recognition module, a proximity sensor, a fingerprint scanner, a retina scanner, a voice recognition module, or other known interfacing means.

FIG. 1*b* shows an embodiment of a user **120b** entering one or more user inputs into an input receptor **100b** by pressing at least one button **102b** on a user interface **101b**. The one or more user inputs may comprise a keystroke, or any other action receivable by a user interface. As the user **120b** supplies each of the one or more user inputs to the user interface **101b**, the input receptor **100b** may send a signal **130b** representing each of the user inputs to a central signal switch **110b**. The central signal switch **110b** may perform an operation upon receipt of a correct succession of signals or deny an operation upon receipt of an incorrect succession signals.

FIG. 2 shows an embodiment of an enclosed area **250** comprising an access barrier **260**, such as a door, for blocking or allowing access to the enclosed area **250**. The access barrier **260** may comprise an actionable device **270**, such as a garage door motor or a door lock, for permitting or denying access to the enclosed area **250**. A central signal switch **210** may be connected to the actionable device **270**, wherein the central signal switch **210** is capable of actuating the actionable device **270**.

An input receptor **200** capable of receiving one or more user inputs may be disposed in, near, or on an exterior **251** of the enclosed area **250**. The input receptor **200** may be connected to a central signal switch **210** via a wireless connection capable of sending one or more user inputs **230** to the central signal switch **210**. For example, if a user supplies one or more user inputs to the input receptor **200**, the input receptor **200** may send the user inputs **230** to the central signal switch **210**. If the user inputs **230** are found to be acceptable at the central signal switch **210**, such as being one of a list of acceptable inputs, the central signal switch **210** may perform an operation, such as opening or closing the access barrier **260**, or engaging or disengaging a door lock.

The central signal switch **210** may also be connected to a network **2000**, such as a local area network or the Internet. The central signal switch **210** may receive digital data **240** through the network **2000** from one or more electronic devices **2100** connected to the network **2000**. In the embodiment shown, the one or more electronic devices **2100** comprises a smartphone, however, other embodiments may comprise a laptop or desktop computer, a tablet, or other devices capable of communicating over such a network. The one or more electronic devices **2100** may comprise a software application for management of the central signal switch **210** including creating, deleting, or editing one or more acceptable inputs.

Additionally, the software application may be used to create, delete, or edit one or more input parameters. Such input parameters may be used to determine one or more conditions upon which an actuated system may operate. For example, the one or more input parameters may comprise a predetermined user interface interaction sequence, such as a

combination of keystrokes supplied by a user, a combination of user inputs, a predetermined sequence of user inputs, a time window during which the central signal switch **210** may receive one or more user inputs, a limitation on which one or more user inputs may be supplied to gain access to the secure area **250**, or a limitation on how many times one or more user inputs may be received by the central signal switch **210**.

FIGS. 3*a* and 3*b* show a perspective view and a partially-cutaway perspective view, respectively, of an embodiment of an input receptor **300b** comprising an interface **301a** and an interior **306b** with a plurality of components supported by a printed circuit board **309b** disposed therein.

The printed circuit board **309b** may support at least a microcontroller **311b** and a communication device **303b**. After a user supplies one or more user inputs, the input receptor **300b** may transmit the one or more user inputs to a central signal switch (not shown). The central signal switch may store and compare one or more acceptable inputs to the one or more user inputs. If the one or more user inputs match the one or more acceptable inputs, the central signal switch may perform an operation.

The communication device **303b** may comprise a radio frequency transceiver or other known communication apparatus. The communication device **303b** may communicate at a sub-1 GHz frequency. It may be appreciated by those of ordinary skill in the art that communications at sub-1 GHz frequencies may be more capable of propagating through environmental obstacles, such as a plurality of walls in a residential home, than communications at frequencies higher than 1 GHz. It may therefore be desirable for said communication device **303b** to transmit signals at a sub-1 GHz frequency. In some applications, it may be desirable to communicate at a 2.4 GHz or 5.8 GHz frequency to achieve compatibility with other devices, such as those that communicate using ZigBee, Z-Wave, Bluetooth, or Wi-Fi.

The input receptor **300b** may be powered by a portable power source **304b**, such as one or more galvanic or voltaic batteries, one or more solar cells, or other known means of portable power. The input receptor **300b** may execute a low power function after a user has submitted a user input to the user interface **301a**. Such a low power function may be executed for a predetermined amount of time or until a user starts to use the user interface **301a** again. When the low power function is executed, the input receptor **300b** may cut power from unneeded subsystems and reduce power in others until reactivated. This low power function, combined with not requiring continuous intermittent communication with the network, may enable the portable power source **304b** of the input receptor **300b** to last significantly longer than portable power sources of other known remote actuation systems.

The input receptor **300b** may further comprise one or more surveillance devices **305b** disposed thereon or therein, such as a security camera, a microphone, a proximity sensor, or other known surveillance means. For example, a security camera may be disposed within the interior **306b** of the input receptor **300b**, with a lens of the camera extending through an exterior **307b** of the input receptor **300b**. The one or more security devices **305b** may continuously gather and transmit information from an environment to a central signal switch as shown in FIG. 2. Additionally, the one or more surveillance devices **305b** may trigger the input receptor **300b** to exit the low power function when the one or more surveillance devices **305b** detect a user.

The input receptor **300b** may comprise one or more data connection ports **308b** for interacting with firmware of the



## 5

input receptor **300b**, such as altering or updating the firmware, running system diagnostics, or managing acceptable inputs and/or input parameters. In some embodiments, such firmware functions may also be performed via a network. The one or more data connection ports **308b** may be disposed on the interior **306b** of the input receptor **300b** to aid in preventing undesired access or accumulation of debris from the surrounding environment. The one or more data connection ports **308b** may be able to be accessed by detaching a portion of the exterior **307b** of the input receptor **300b**.

FIG. 4 shows an interior **406** of an embodiment of a central signal switch **410** with a plurality of components supported by a printed circuit board **409** disposed therein. An actionable device **470**, shown as a garage door opener, may be connected to and controlled by the central signal switch **410**.

The central signal switch **410** may comprise a microcontroller **411** and an internal memory unit **412** for obtaining and storing one or more acceptable inputs and/or input parameters. The central signal switch **410** may also comprise a communication device **413**, such as a radio frequency transceiver, for receiving one or more user inputs from an input receptor (not shown). If at least one of the user inputs received from the input receptor matches one of the acceptable inputs, the central signal switch **410** may send a command to at least one actionable device **470**, a network, or a combination thereof, to perform an operation.

In various embodiments, an actionable device may comprise an access control device, such as an electromechanical door lock, a garage door motor, or another access restricting mechanism. Actuation of the access control device may comprise an opening of a door or an engagement or disengagement of a lock. In these embodiments, a user may gain access to a secure area by supplying inputs to an input receptor that match one or more acceptable inputs. In other embodiments, an actionable device may comprise a thermostat, a television, an automated window, automated blinds, a ventilation system, a sprinkler system, a lighting element, an indoor positioning system, or other such devices known in the art. The central signal switch **410** may further comprise a portable power source **404** to provide backup power in case of a power loss.

The central signal switch **410** may further comprise at least one data connection port **408** for interacting with firmware of the central signal switch **410**, such as altering or updating the firmware, running system diagnostics, or managing acceptable inputs and/or input parameters. The data connection port **408** may be disposed on an interior **406** of the central signal switch **410**, to aid in preventing undesired access or accumulation of debris.

Whereas the present invention has been described in particular relation to the drawings attached hereto, it should be understood that other and further modifications apart from those shown or suggested herein, may be made within the scope and spirit of the present invention.

What is claimed is:

1. A secure remote actuation system, comprising:
  - a remote input receptor disposed outside an enclosure comprising:
    - a user interface that receives one or more user inputs from a user; and
    - a first microcontroller that sends a signal for each input of the one or more user inputs as the user interface receives the input; and

## 6

a central signal switch disposed inside the enclosure and wirelessly connected to the remote input receptor, the central signal switch comprising:

- a memory that stores one or more acceptable inputs; and

- a second microcontroller that obtains a succession of signals from the remote input receptor, the succession of signals corresponding to the one or more user inputs, and compares said one or more user inputs to said one or more acceptable inputs, wherein the second microcontroller obtains each signal in the succession of signals from the remote input receptor as the remote input receiver receives each input from the user.

2. The secure remote actuation system of claim 1, wherein the remote input receptor further comprises one or more communication devices for sending said signal.

3. The secure remote actuation system of claim 2, wherein said one or more communication devices is a radio frequency transceiver.

4. The secure remote actuation system of claim 1, wherein the remote input receptor further comprises a portable power source.

5. The secure remote actuation system of claim 1, wherein the user interface comprises buttons, a visual display, one or more capacitive sensors, a microphone, a vibration recognition module, a proximity sensor, a fingerprint scanner, a retina scanner, a voice recognition module, or a combination thereof.

6. The secure remote actuation system of claim 1, wherein the central signal switch comprises one or more data connection ports.

7. The secure remote actuation system of claim 6, wherein the one or more data connection ports are disposed in an interior of the central signal switch.

8. The secure remote actuation system of claim 1, wherein said memory further stores said one or more user inputs; a history of user inputs; one or more input parameters; or a combination thereof.

9. The secure remote actuation system of claim 1, wherein the remote input receptor executes a low power function after said one or more user inputs is received from the user.

10. The secure remote actuation system of claim 9, wherein the remote input receptor exits said low power function when the user begins to use the user interface.

11. The secure remote actuation system of claim 1, wherein the remote input receptor further comprises a surveillance device to detect a user.

12. The secure remote actuation system of claim 11, wherein the remote input receptor exits a low power function when the surveillance device detects the user.

13. The secure remote actuation system of claim 11, wherein the surveillance device comprises a camera, a microphone, a proximity sensor, or a combination thereof.

14. The secure remote actuation system of claim 1, wherein said cloud-based network comprises a software application for an individual to control said one or more acceptable inputs at said central signal switch.

15. The secure remote actuation system of claim 14, wherein said controlling said one or more acceptable inputs comprises editing, adding, or deleting the one or more acceptable inputs; creating, deleting, or editing one or more input parameters; changing personal settings; conducting diagnoses; and altering or updating firmware.

**16.** The remote actuation system of claim **1**, wherein said remote input receptor comprises one or more data connection ports to interact with firmware of the remote input receptor.

**17.** The secure remote actuation system of claim **1**,  
5 wherein said central signal switch is connected to and controls a network of actionable devices.

**18.** The secure remote actuation system of claim **17**,  
wherein said network of actionable devices comprises  
access control devices, thermostats, televisions, automated  
10 windows, automated blinds, ventilation systems, sprinkler  
systems, lighting elements, indoor positioning systems, and  
combinations thereof.

**19.** The secure remote actuation system of claim **18**,  
wherein said access control devices are electromechanical  
15 locking mechanisms.

**20.** The secure remote actuation system of claim **18**,  
wherein said access control devices secure an enclosed area,  
room, building, or delivery box.

\* \* \* \* \*

20