



US009933784B1

(12) **United States Patent**
Herbach et al.

(10) **Patent No.:** **US 9,933,784 B1**
(45) **Date of Patent:** ***Apr. 3, 2018**

(54) **AUGMENTED TRAJECTORIES FOR
AUTONOMOUS VEHICLES**

(56) **References Cited**

(71) Applicant: **Waymo LLC**, Mountain View, CA
(US)

5,983,161 A 11/1999 Lemelson et al.
6,064,926 A 5/2000 Sarangapani et al.

(Continued)

(72) Inventors: **Joshua Seth Herbach**, Mountain View,
CA (US); **Nathaniel Fairfield**,
Mountain View, CA (US)

FOREIGN PATENT DOCUMENTS

EP 1 395 888 3/2004
EP 2 277 758 1/2011

(Continued)

(73) Assignee: **Waymo LLC**, Mountain View, CA
(US)

OTHER PUBLICATIONS

(*) Notice: Subject to any disclaimer, the term of this
patent is extended or adjusted under 35
U.S.C. 154(b) by 0 days.

Cremean, Lars B., et al. "Alice: An information-rich autonomous
vehicle for high-speed desert navigation." *Journal of Field Robotics*,
2006, pp. 777-810, vol. 23, No. 9.

(Continued)

This patent is subject to a terminal dis-
claimer.

(21) Appl. No.: **15/372,071**

Primary Examiner — Ronnie Mancho

(74) *Attorney, Agent, or Firm* — McDonnell Boehnen
Hulbert & Berghoff LLP

(22) Filed: **Dec. 7, 2016**

Related U.S. Application Data

(63) Continuation of application No. 14/679,471, filed on
Apr. 6, 2015, now Pat. No. 9,541,410, which is a
(Continued)

(51) **Int. Cl.**
G06F 19/00 (2011.01)
G05D 1/02 (2006.01)
G07C 5/00 (2006.01)

(52) **U.S. Cl.**
CPC **G05D 1/0212** (2013.01); **G05D 1/0231**
(2013.01); **G07C 5/008** (2013.01); **G05D**
2201/0213 (2013.01)

(58) **Field of Classification Search**
CPC G08G 1/166; G08G 1/167; G08G 1/163;
G08G 1/164; G08G 1/165;

(Continued)

(57) **ABSTRACT**

An autonomous vehicle may include a stuck condition
detection component and a communications component.
The stuck-detection component may be configured to detect
a condition in which the autonomous vehicle is impeded
from navigating according to a first trajectory. The commu-
nications component may send an assistance signal to an
assistance center and receive a response to the assistance
signal. The assistance signal may include sensor information
from the autonomous vehicle. The assistance center may
include a communications component and a trajectory speci-
fication component. The communications component may
receive the assistance signal and send a corresponding
response. The trajectory specification component may
specify a second trajectory for the autonomous vehicle and
generate the corresponding response that includes a repre-
sentation of the second trajectory. The second trajectory may
be based on the first trajectory and may ignore an object that
obstructs the first trajectory.

20 Claims, 19 Drawing Sheets

100

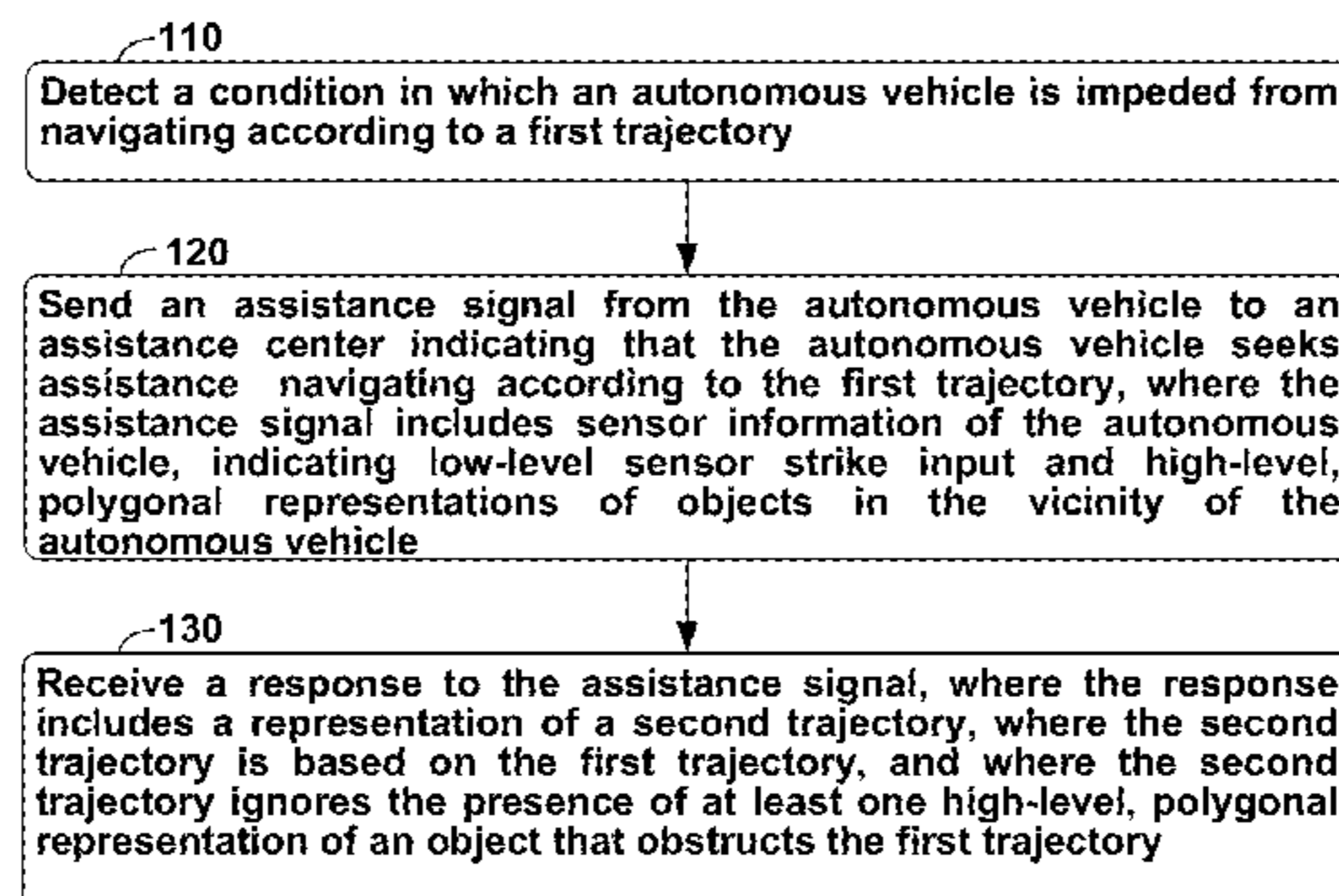

Related U.S. Application Data

continuation of application No. 13/837,573, filed on Mar. 15, 2013, now Pat. No. 9,008,890.

(58) **Field of Classification Search**

CPC G08G 1/096783; G08G 1/16; G08G 5/025; G08G 5/045; G08G 1/005; G08G 1/09626; G08G 1/096741; G08G 1/096775; G08G 1/127; B60W 2550/402

USPC 701/26
See application file for complete search history.

2011/0241862	A1	10/2011	Debouk et al.
2012/0022716	A1	1/2012	Kitahama et al.
2012/0083959	A1	4/2012	Dolgov et al.
2012/0083960	A1	4/2012	Zhu et al.
2012/0086573	A1	4/2012	Bischoff et al.
2012/0101680	A1	4/2012	Trepagnier et al.
2012/0158280	A1	6/2012	Ravenscroft

FOREIGN PATENT DOCUMENTS

EP	2 405 383	1/2012
WO	2012/047977	4/2012
WO	2012/047980	4/2012

(56) **References Cited**

U.S. PATENT DOCUMENTS

6,836,701	B2	12/2004	McKee
7,050,909	B2	5/2006	Nichols et al.
7,272,474	B1	9/2007	Stentz et al.
7,499,804	B2	3/2009	Svensen et al.
7,539,557	B2	5/2009	Yamauchi
7,627,406	B2	12/2009	Wang et al.
7,734,387	B1	6/2010	Young et al.
7,843,431	B2	11/2010	Robbins et al.
7,894,951	B2	2/2011	Norris et al.
7,979,174	B2	7/2011	Fregene et al.
8,229,618	B2	7/2012	Tolstedt et al.
8,260,483	B2	9/2012	Barfoot et al.
8,280,623	B2	10/2012	Trepagnier et al.
8,311,730	B2	11/2012	Neff
8,315,789	B2	11/2012	Dunbabin et al.
8,374,743	B2	2/2013	Salinger
8,521,415	B2	8/2013	Harada
8,532,862	B2	9/2013	Neff
8,554,397	B1	10/2013	Nishinaga et al.
8,571,742	B2	10/2013	Takeoka
8,577,538	B2	11/2013	Lenser et al.
8,660,734	B2	2/2014	Zhu et al.
8,849,494	B1	9/2014	Herbach et al.
8,996,224	B1	3/2015	Herbach et al.
9,008,890	B1	4/2015	Herbach et al.
9,541,410	B1 *	1/2017	Herbach B60W 30/00
2005/0171654	A1	8/2005	Nichols et al.
2006/0155437	A1	7/2006	Wang et al.
2007/0129869	A1	6/2007	Gudat et al.
2007/0198145	A1	8/2007	Norris et al.
2007/0283036	A1	12/2007	Dey et al.
2008/0014908	A1	1/2008	Vasant
2008/0027591	A1	1/2008	Lenser et al.
2008/0125972	A1	5/2008	Neff
2008/0243388	A1	10/2008	Eguchi et al.
2009/0088916	A1	4/2009	Elgersma et al.
2009/0287367	A1	11/2009	Salinger
2010/0082193	A1	4/2010	Chiappetta
2010/0106356	A1	4/2010	Trepagnier et al.
2011/0035086	A1	2/2011	Kim et al.
2011/0071718	A1	3/2011	Norris et al.
2011/0184605	A1	7/2011	Neff
2011/0211036	A1	9/2011	Tran

OTHER PUBLICATIONS

Dao, Thanh-Son et al., "Markov-Based Lane Positioning Using Intervehicle Communication," IEEE Transactions on Intelligent Transportation Systems, Dec. 2007, pp. 641-650, vol. 8, No. 4.

Jia, Zhen et al., "Vision Based Target Tracking for Autonomous Land Vehicle Navigation: A Brief Survey," Recent Patents on Computer Science, 2009, pp. 32-42, vol. 2, Bentham Science Publishers Ltd.

Ünsal, Cem, Intelligent Navigation of Autonomous Vehicles in an Automated Highway System: Learning Methods and Interacting Vehicles Approach, Dissertation submitted to the Faculty of the Virginia Polytechnic Institute, Jan. 29, 1997, pp. i-185.

Wang, Miao, "Remote controlling an autonomous car with an iPhone," Fachbereich Mathematik und Informatik Serie B—Informatik, Mar. 2010, 5 pages.

Advisory Action for U.S. Appl. No. 13/835,295 dated Jul. 23, 2014, 8 pages.

Final Office Action for U.S. Appl. No. 13/835,295 dated Mar. 4, 2015, 31 pages.

Final Office Action for U.S. Appl. No. 13/835,295 dated May 20, 2014, 23 pages.

Notice of Allowance for U.S. Appl. No. 13/857,573 dated Jan. 7, 2015, 7 pages.

Notice of Allowance for U.S. Appl. No. 13/857,573 dated Oct. 3, 2014, 7 pages.

Notice of Allowance for U.S. Appl. No. 13/837,306 dated Dec. 3, 2014, 7 pages.

Notice of Allowance for U.S. Appl. No. 13/835,448 dated Aug. 18, 2014, 5 pages.

Notice of Allowance for U.S. Appl. No. 13/835,448 dated Apr. 25, 2014, 5 pages.

Office Action for U.S. Appl. No. 13/837,306 dated Jun. 24, 2014, 14 pages.

Office Action for U.S. Appl. No. 13/835,448 dated Feb. 3, 2014, 6 pages.

Office Action for U.S. Appl. No. 13/835,295 dated Nov. 6, 2014, 24 pages.

Office Action for U.S. Appl. No. 13/835,295 dated Dec. 11, 2013, 23 pages.

* cited by examiner

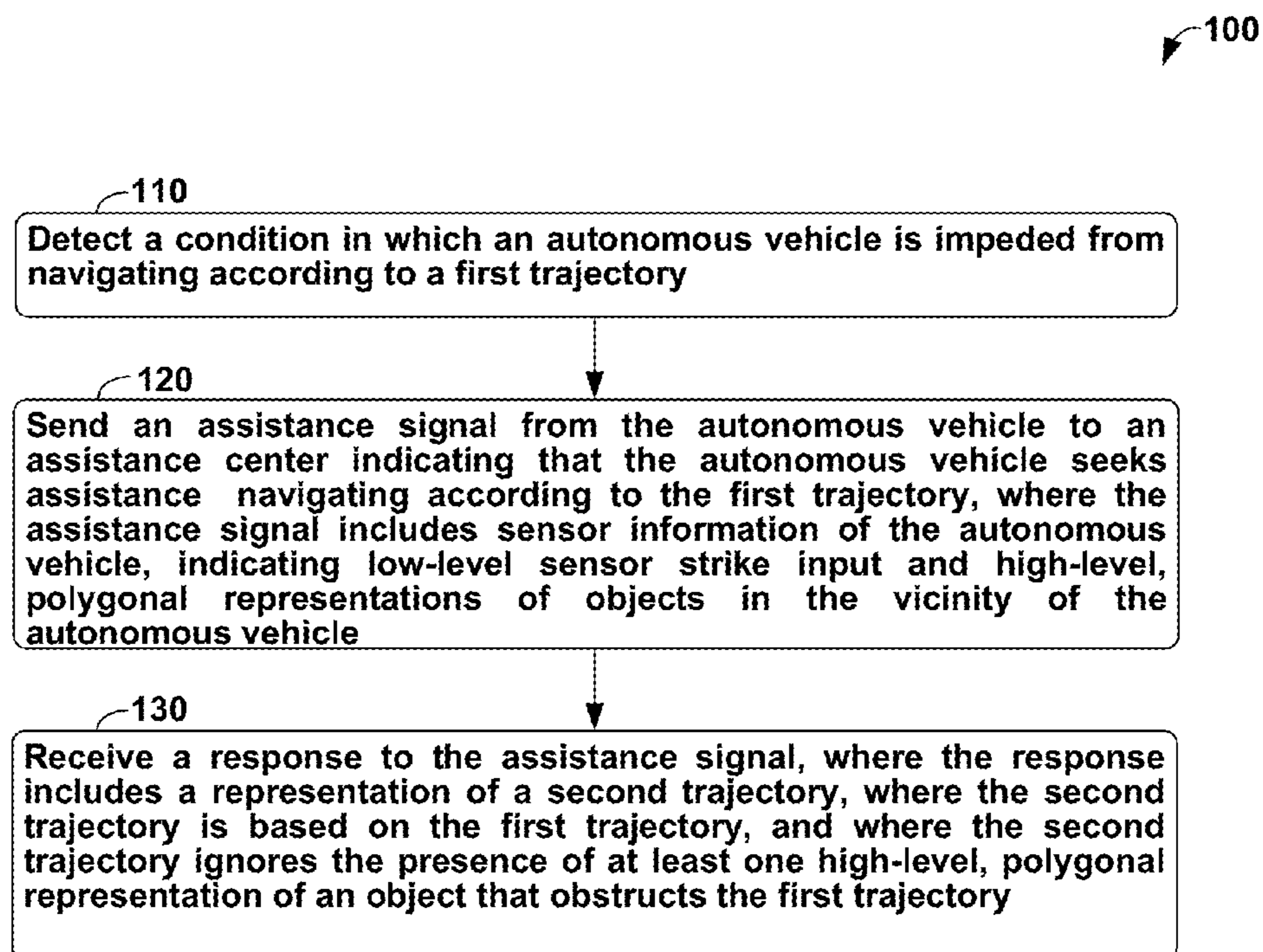

FIG. 1

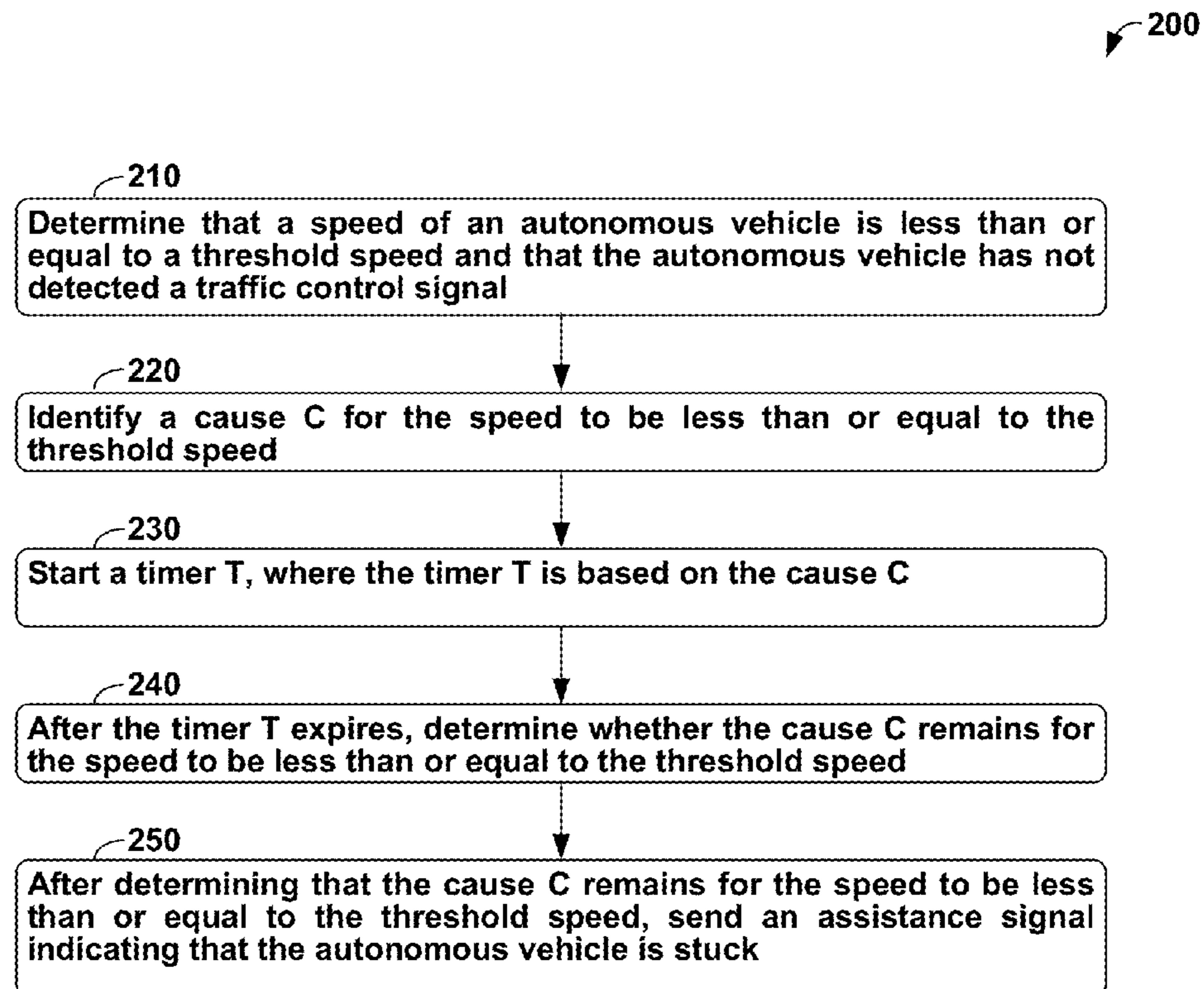

FIG. 2

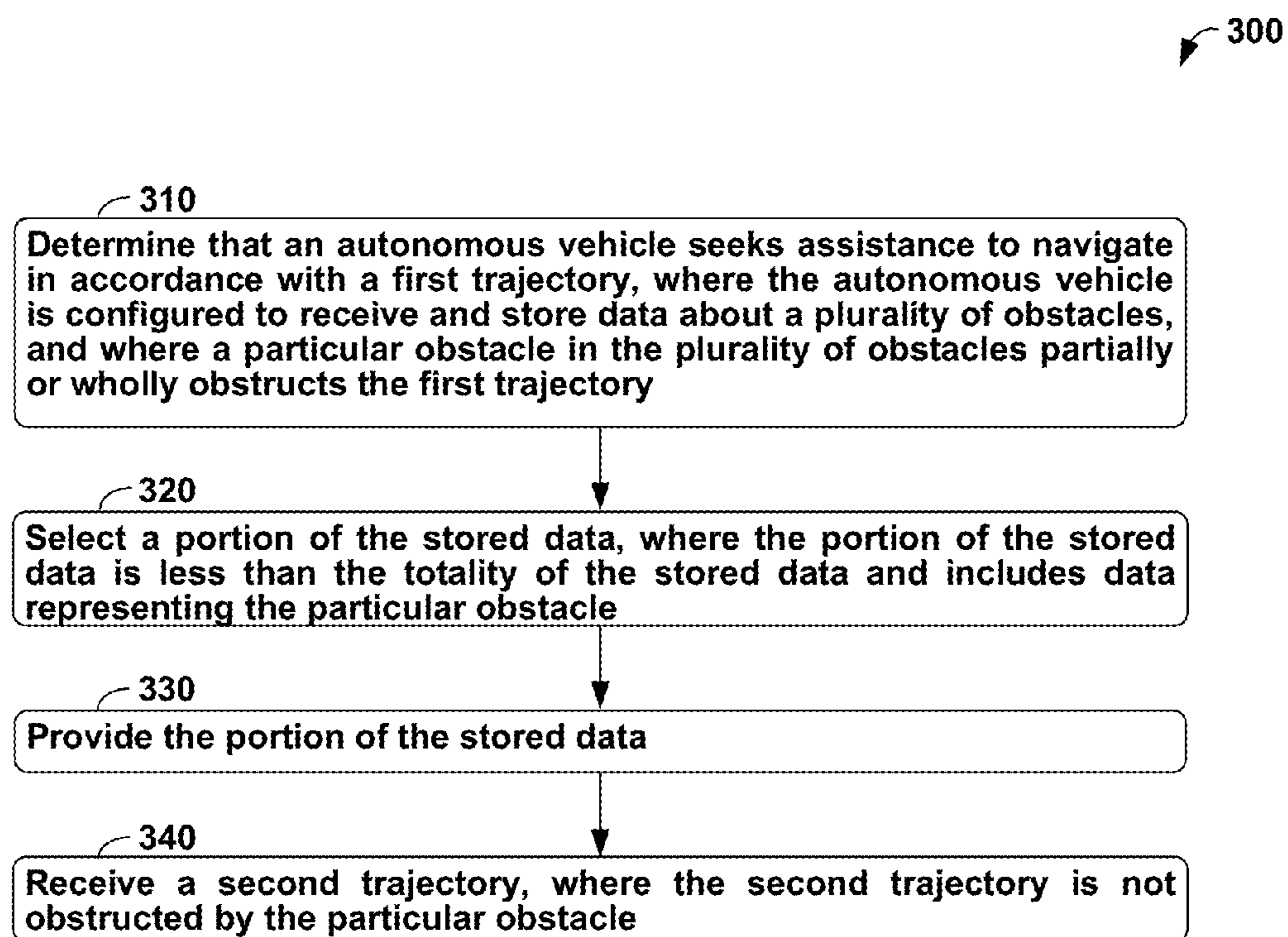

FIG. 3

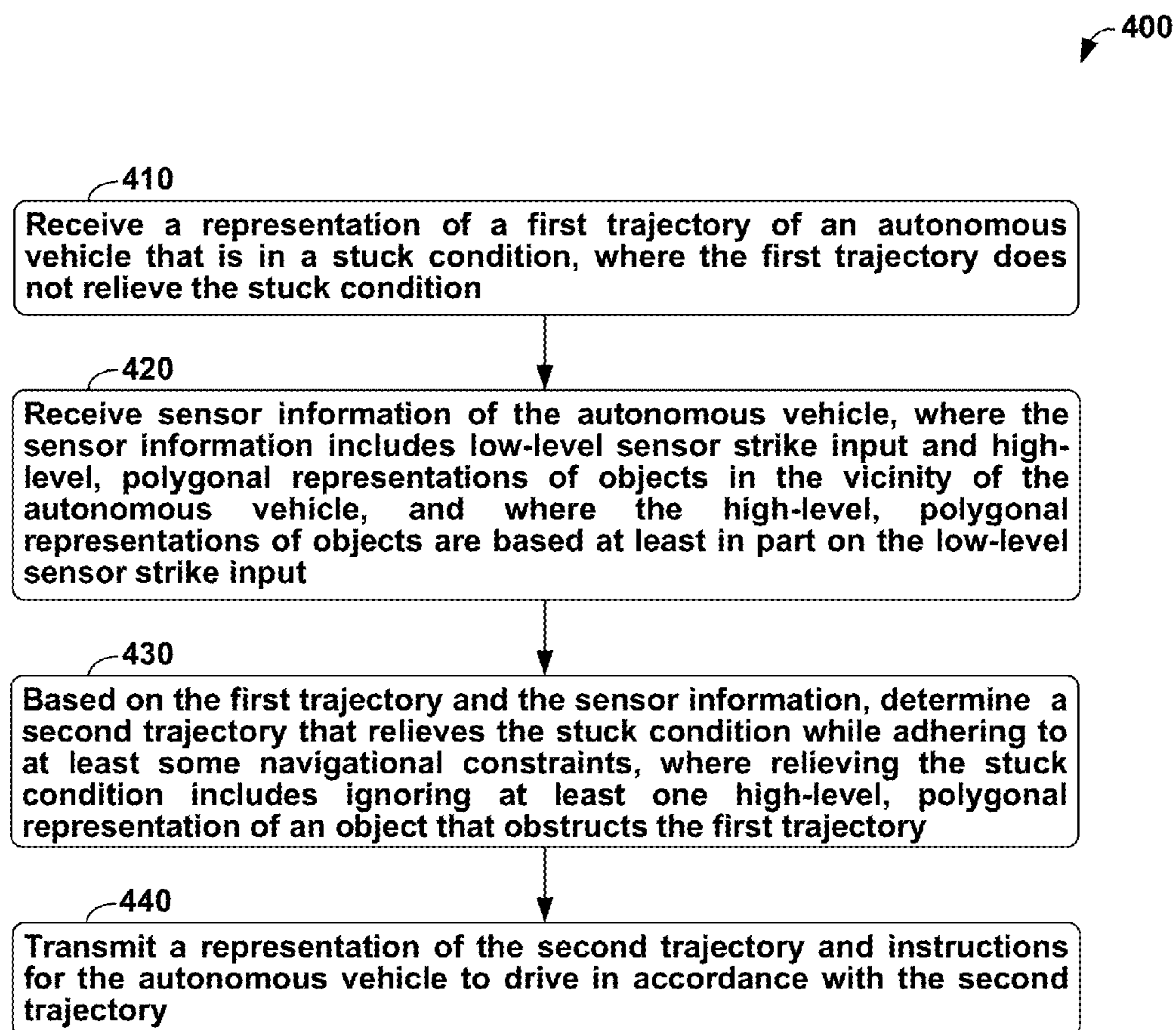

FIG. 4

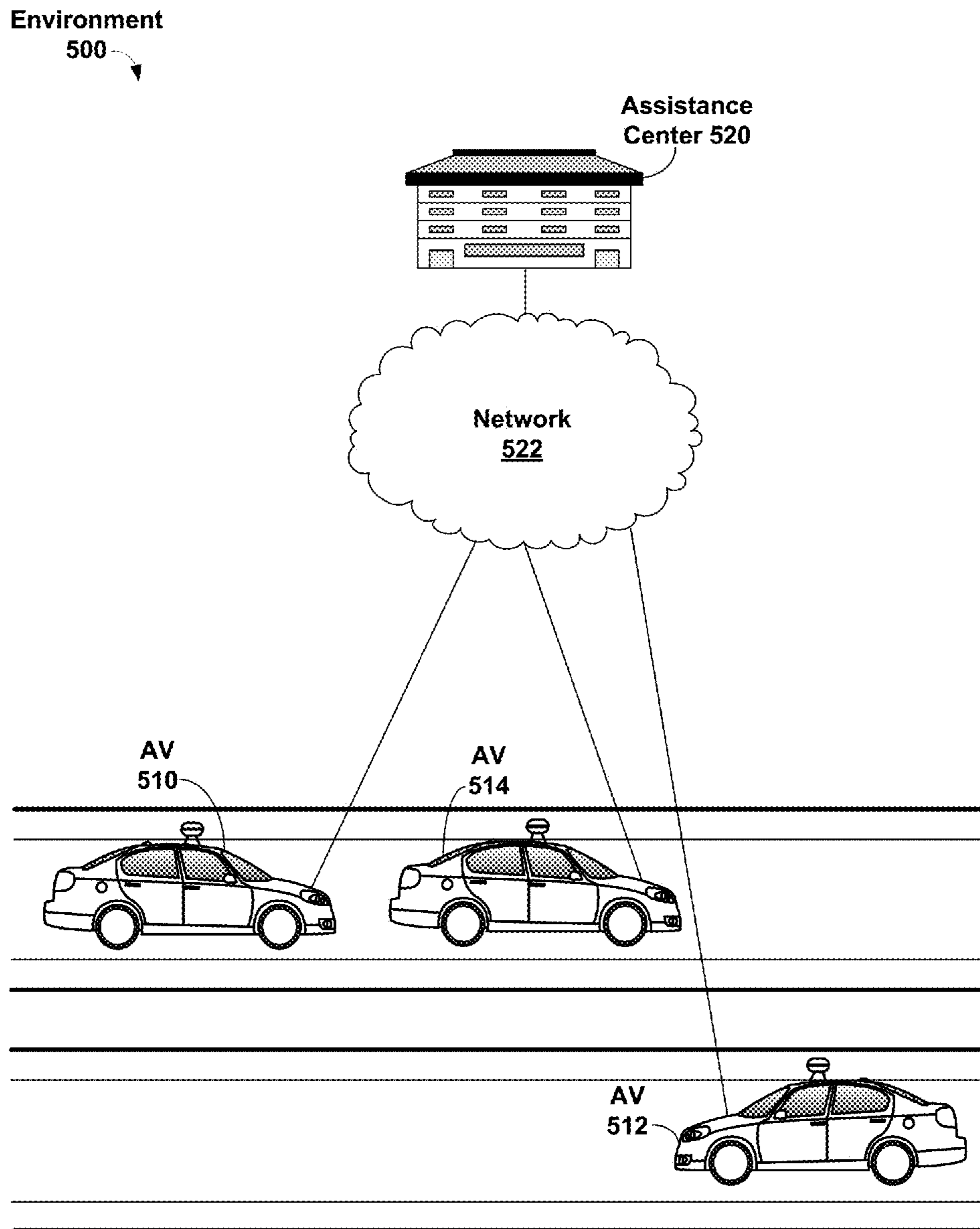

FIG. 5

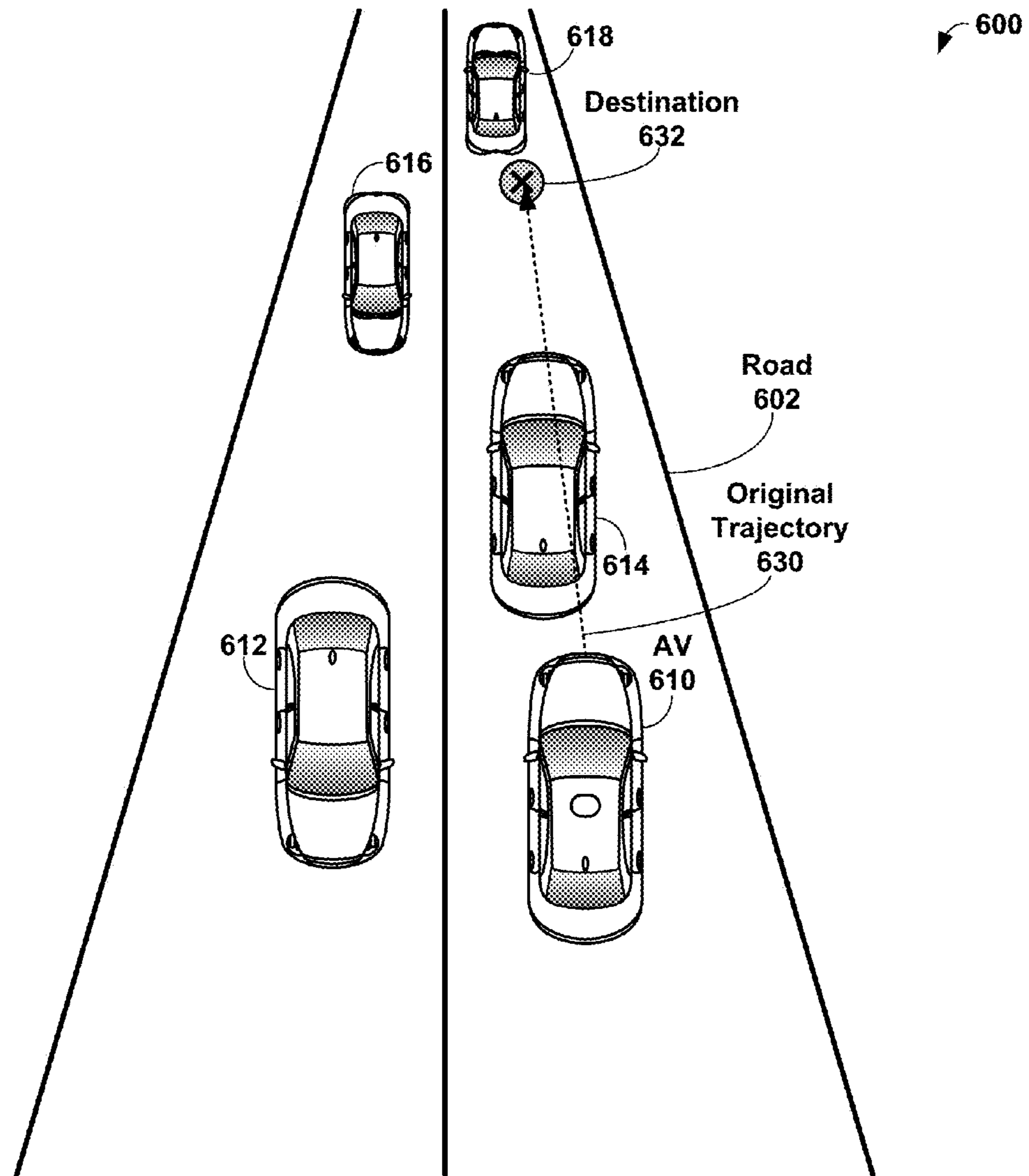

FIG. 6

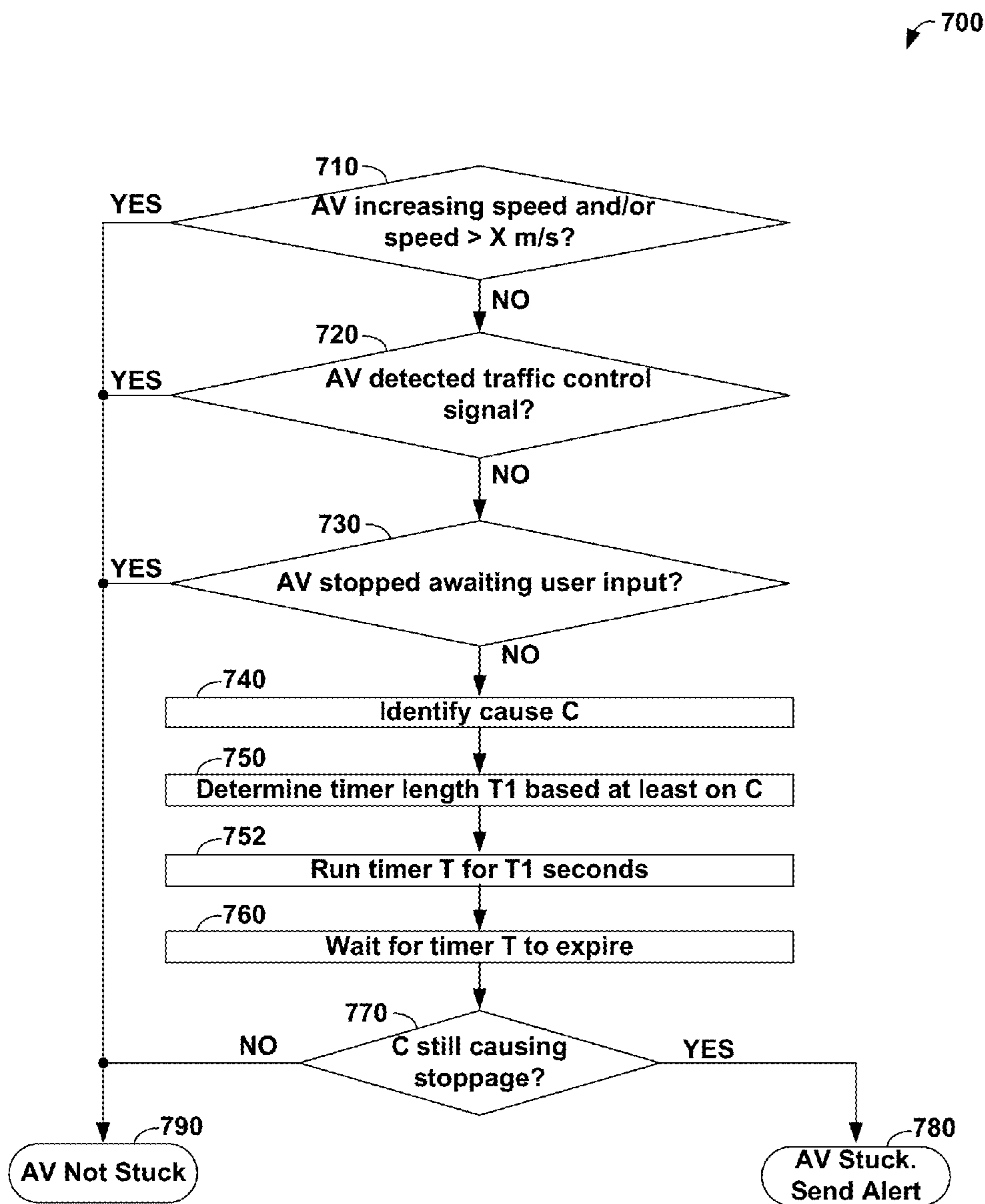

FIG. 7

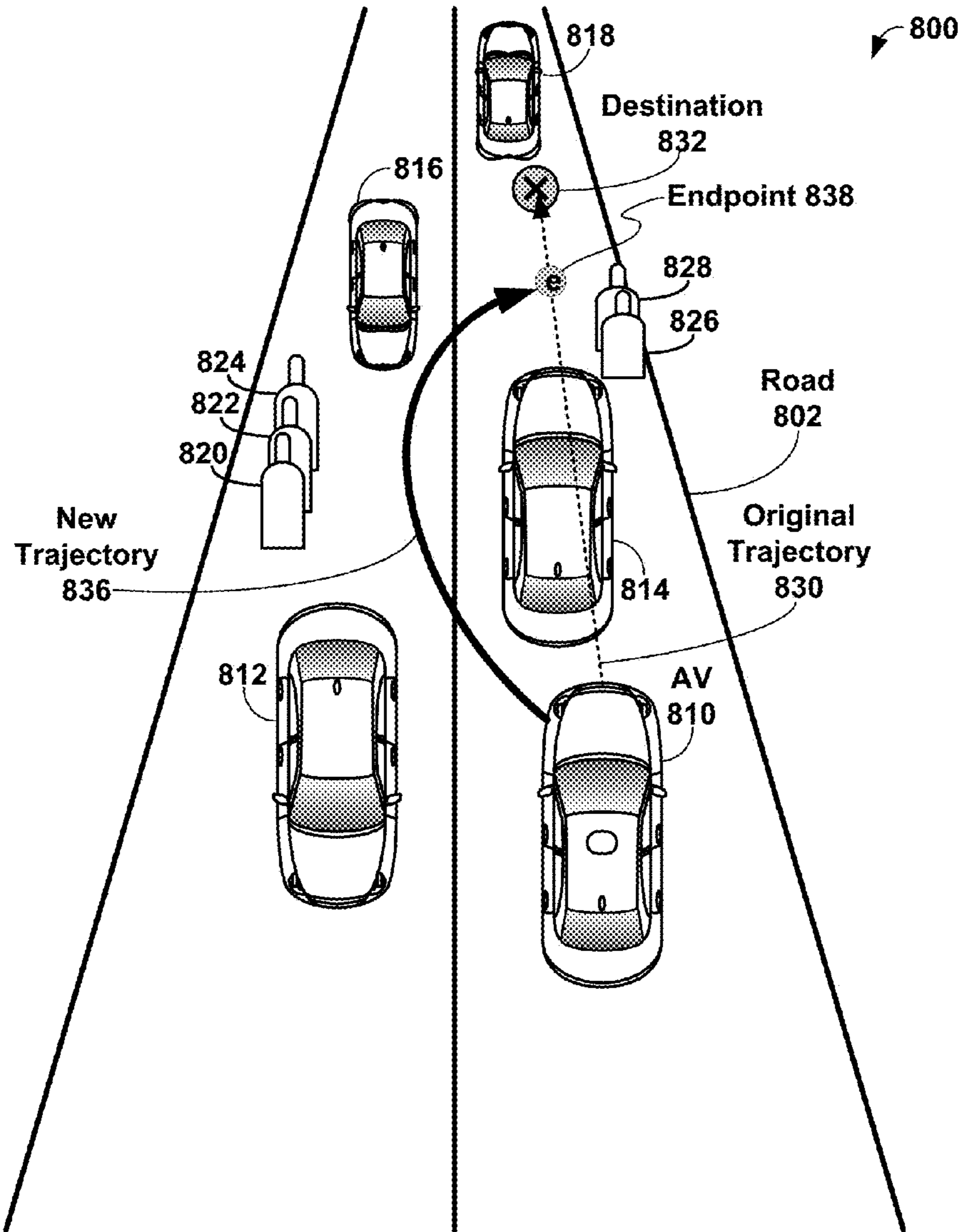

FIG. 8

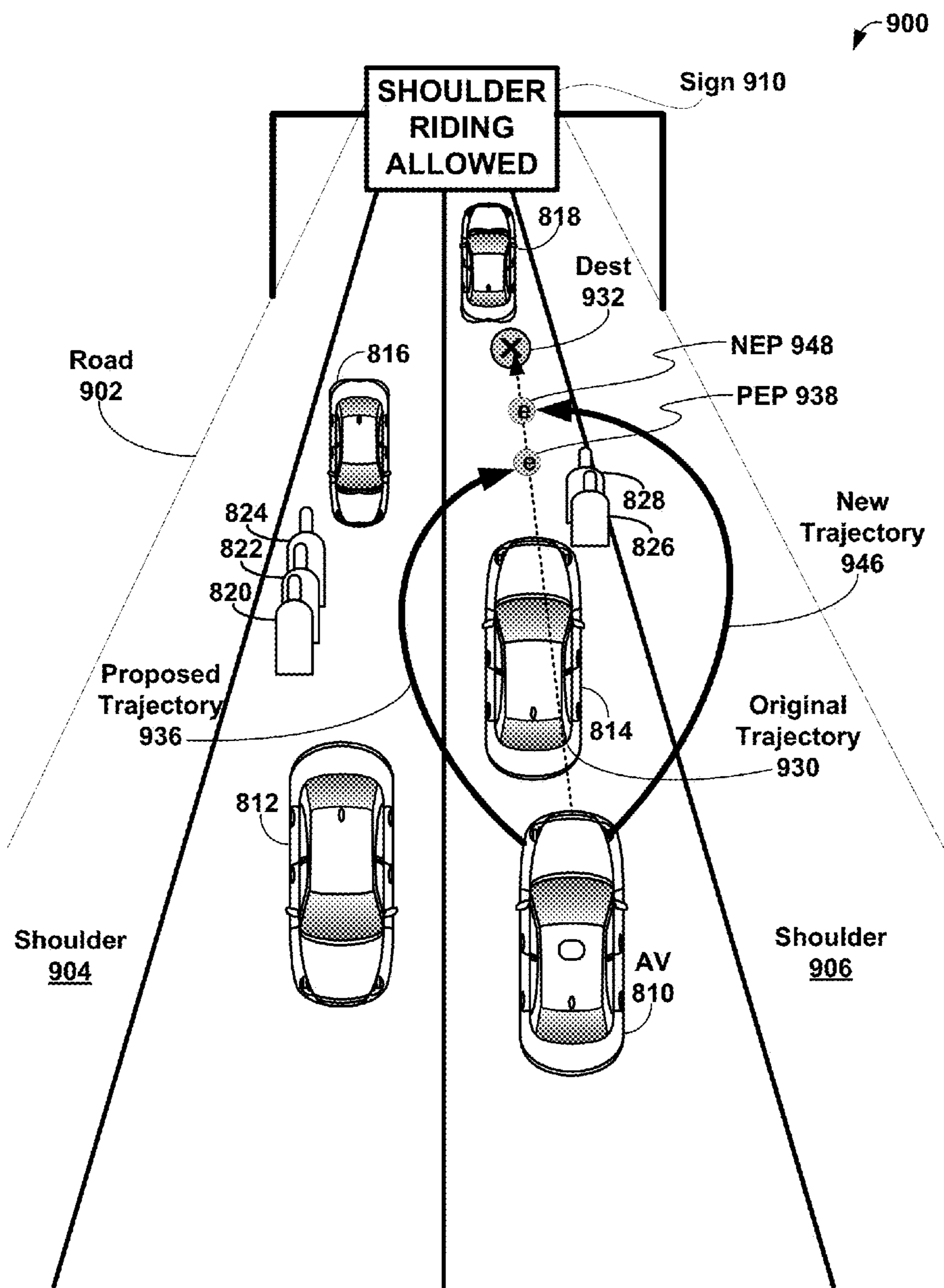

FIG. 9

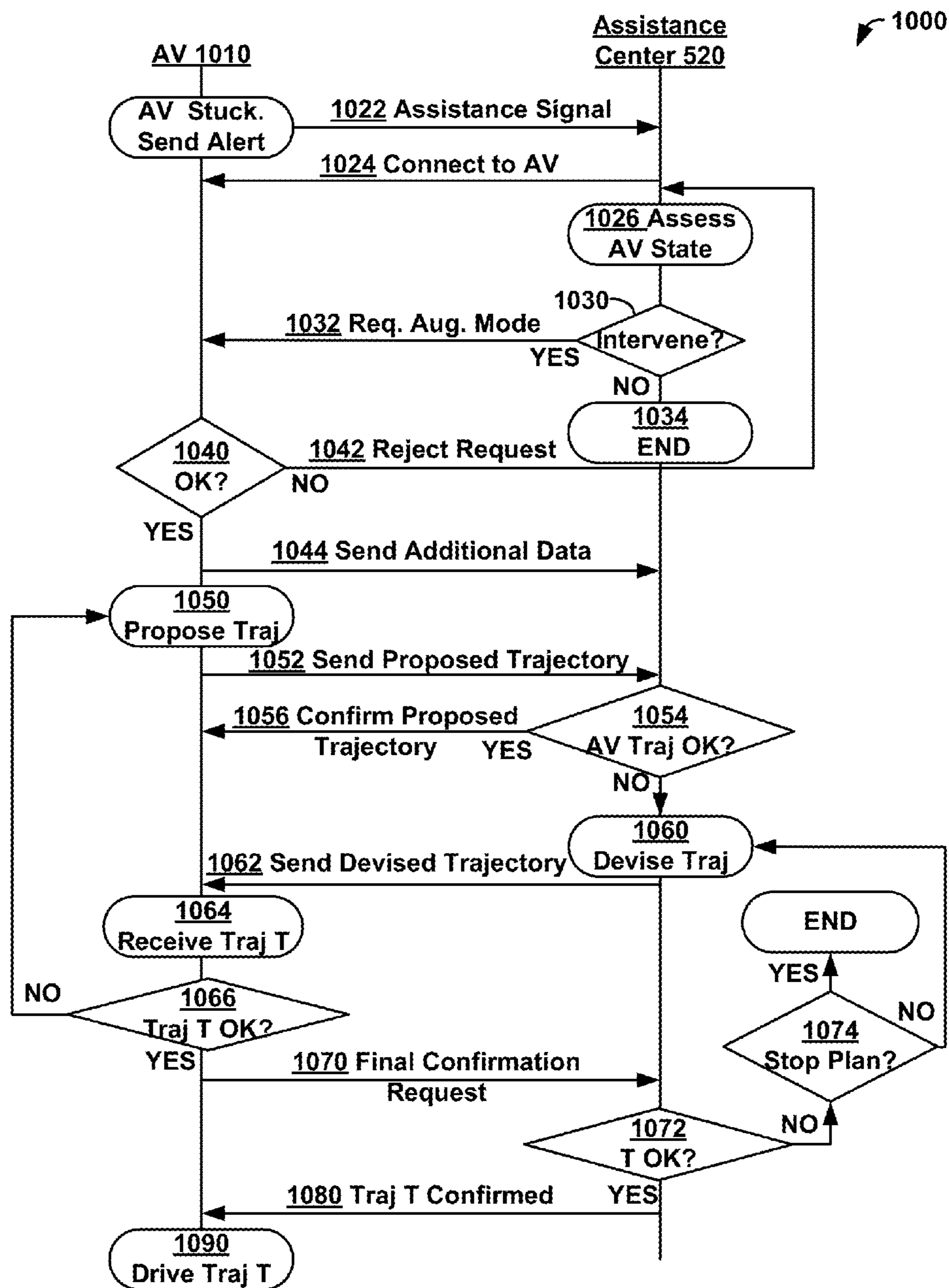
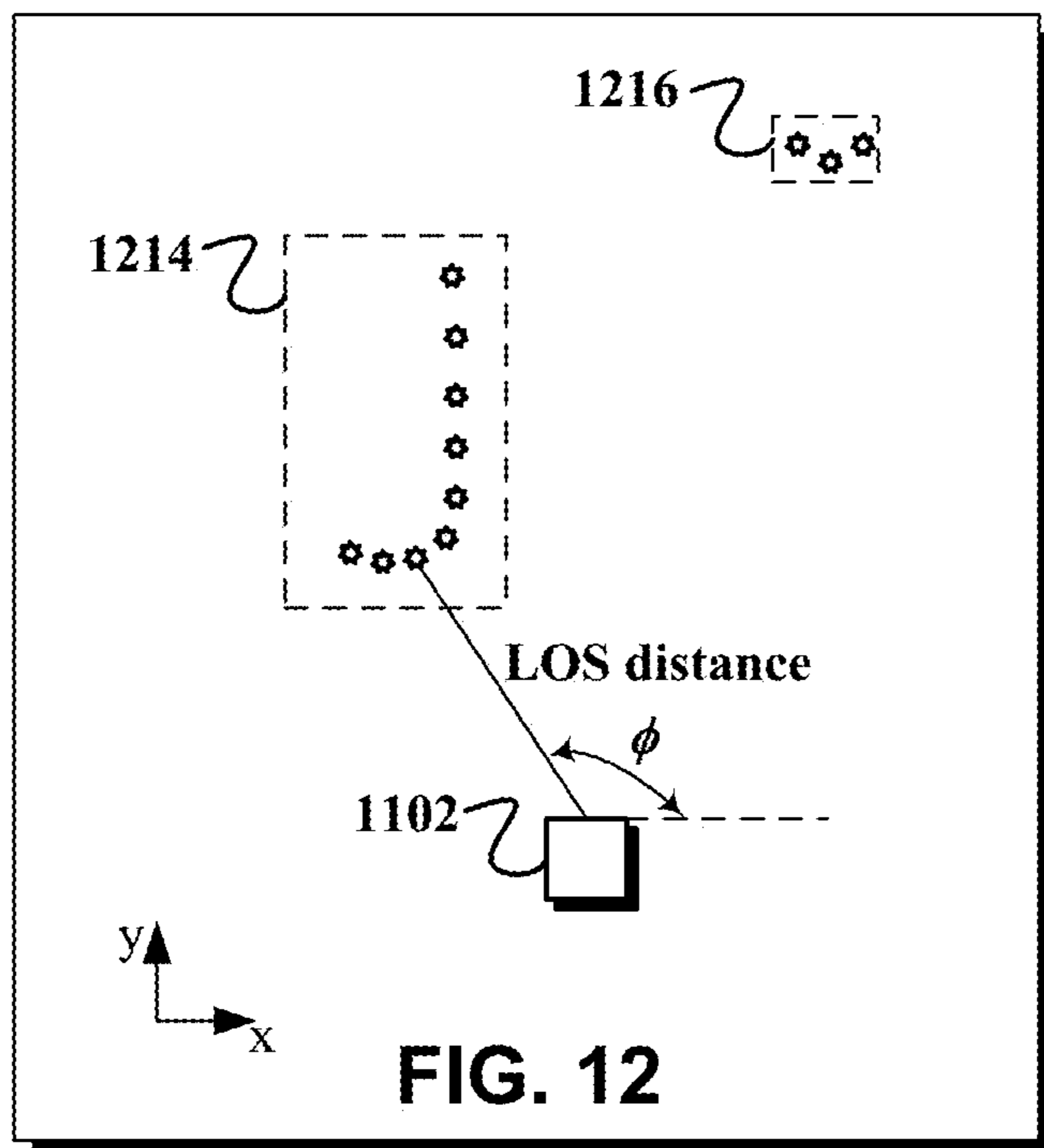
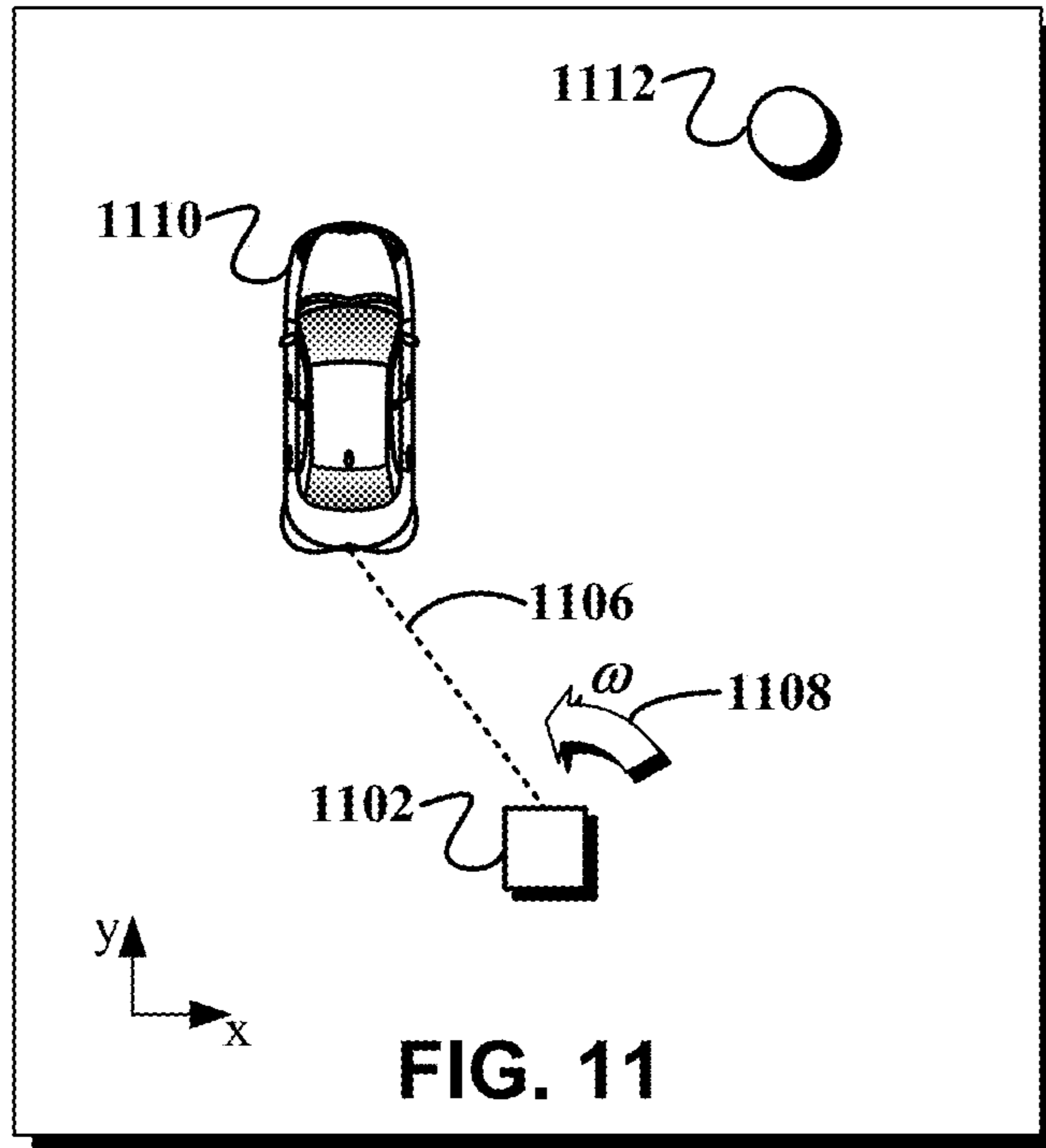

FIG. 10



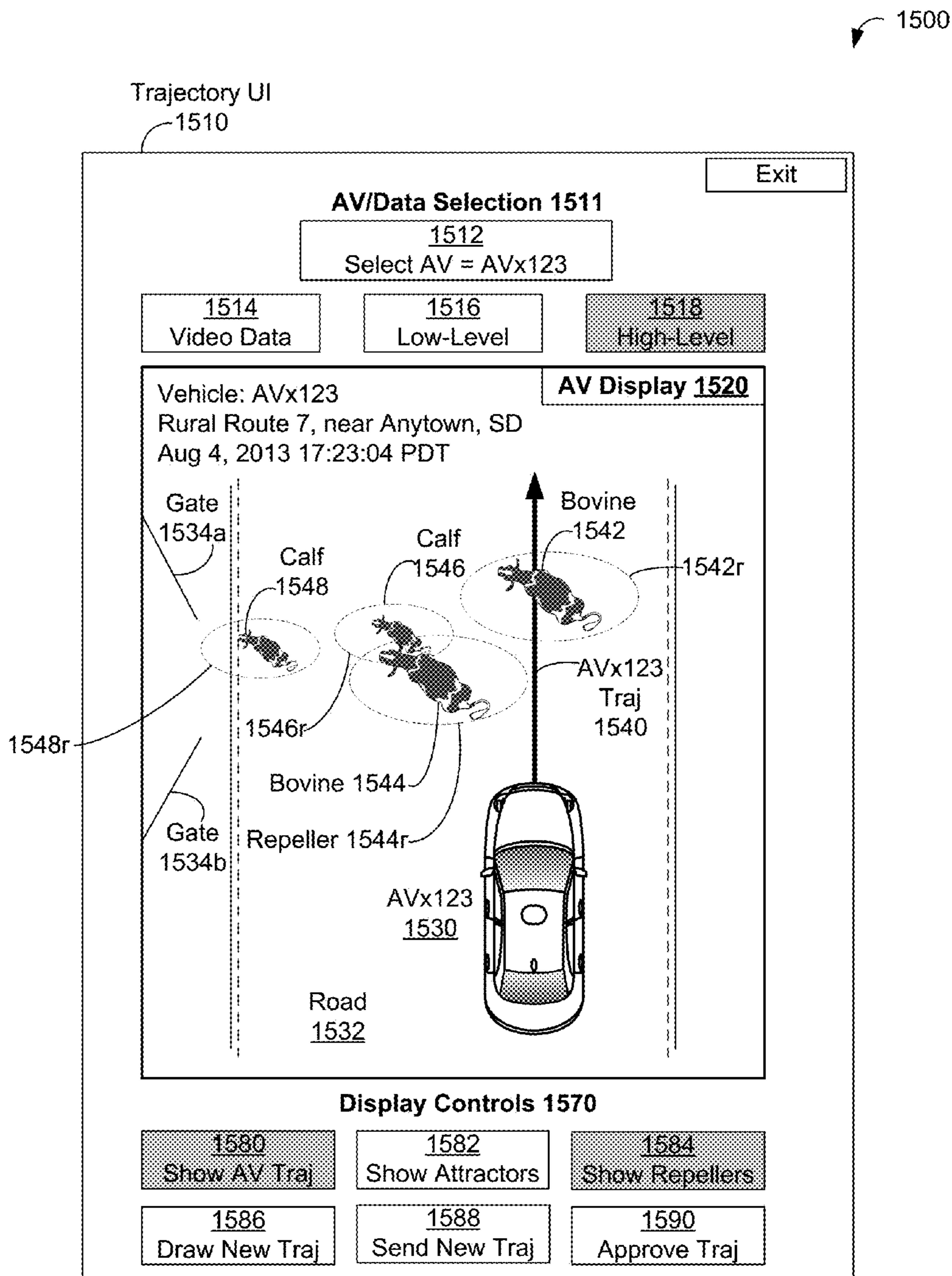

FIG. 15A

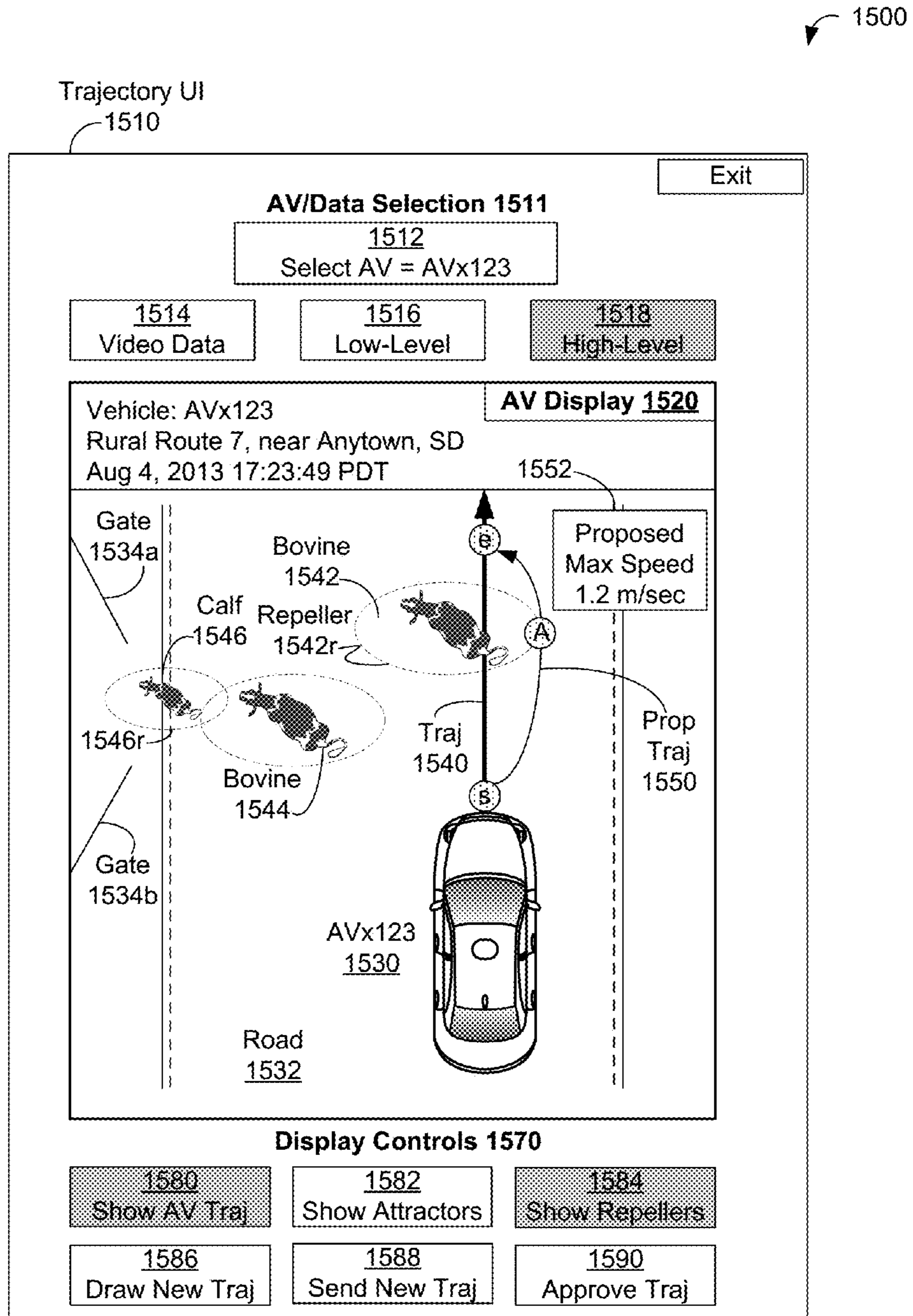

FIG. 15B

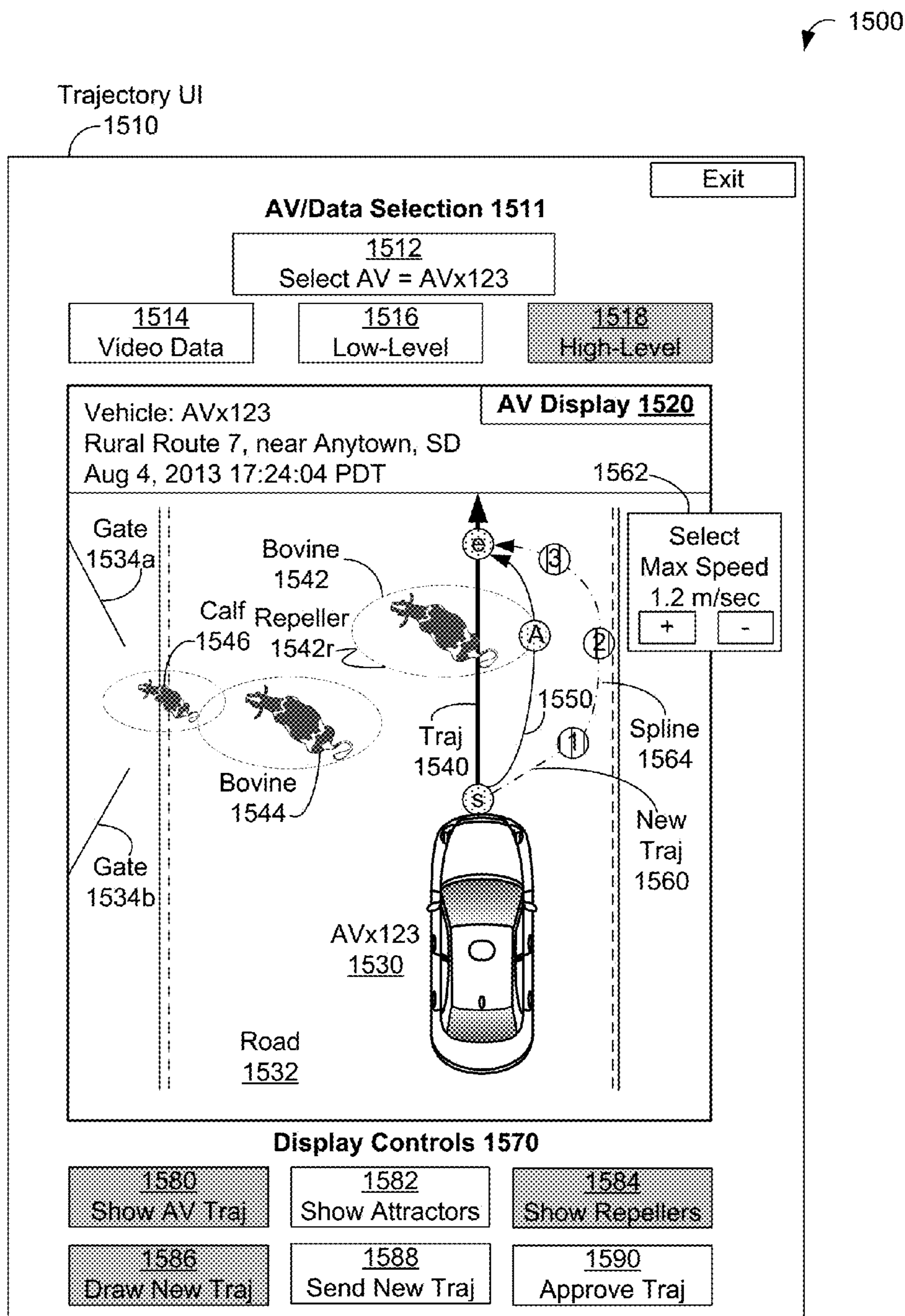

FIG. 15C

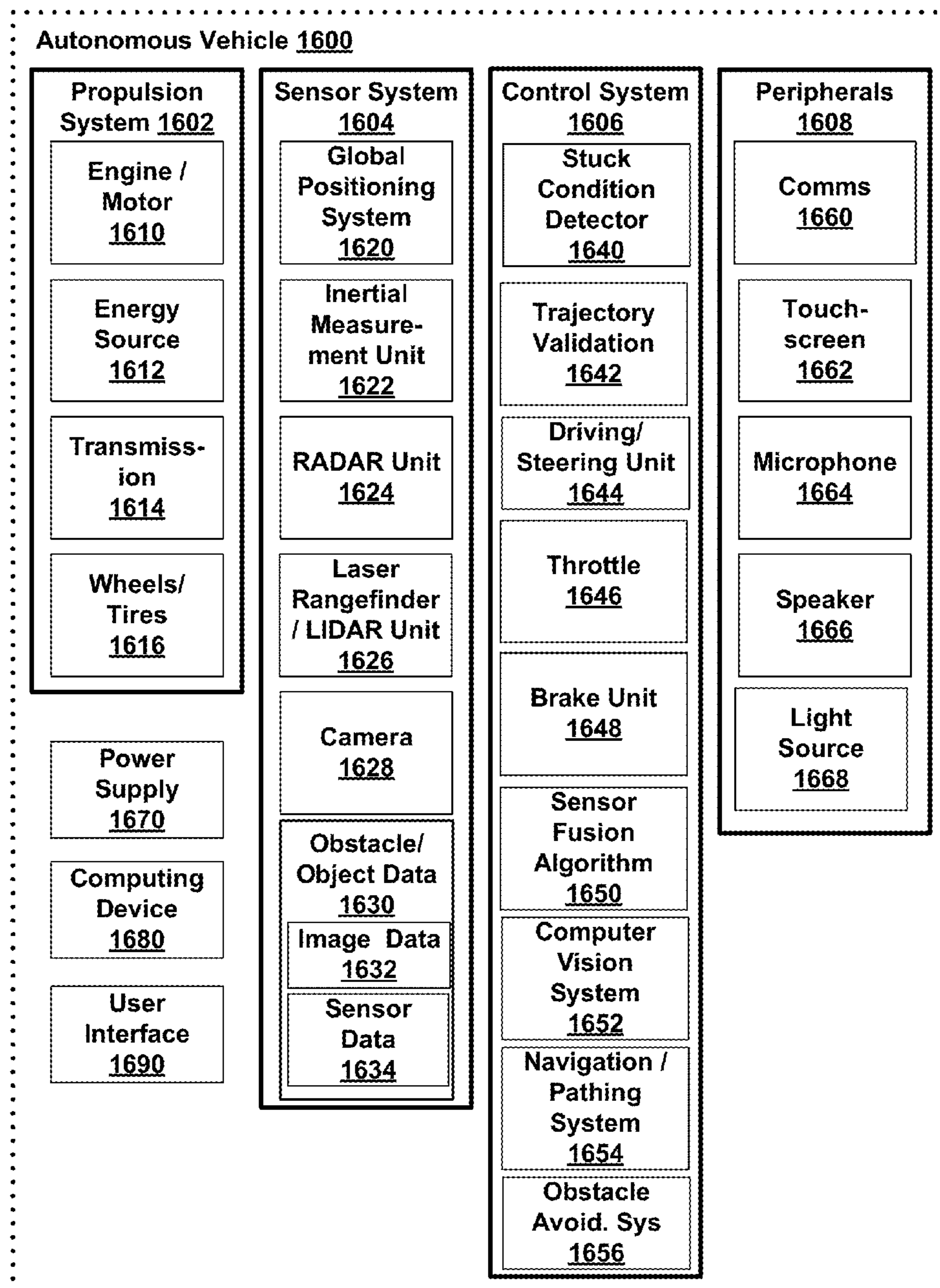

FIG. 16

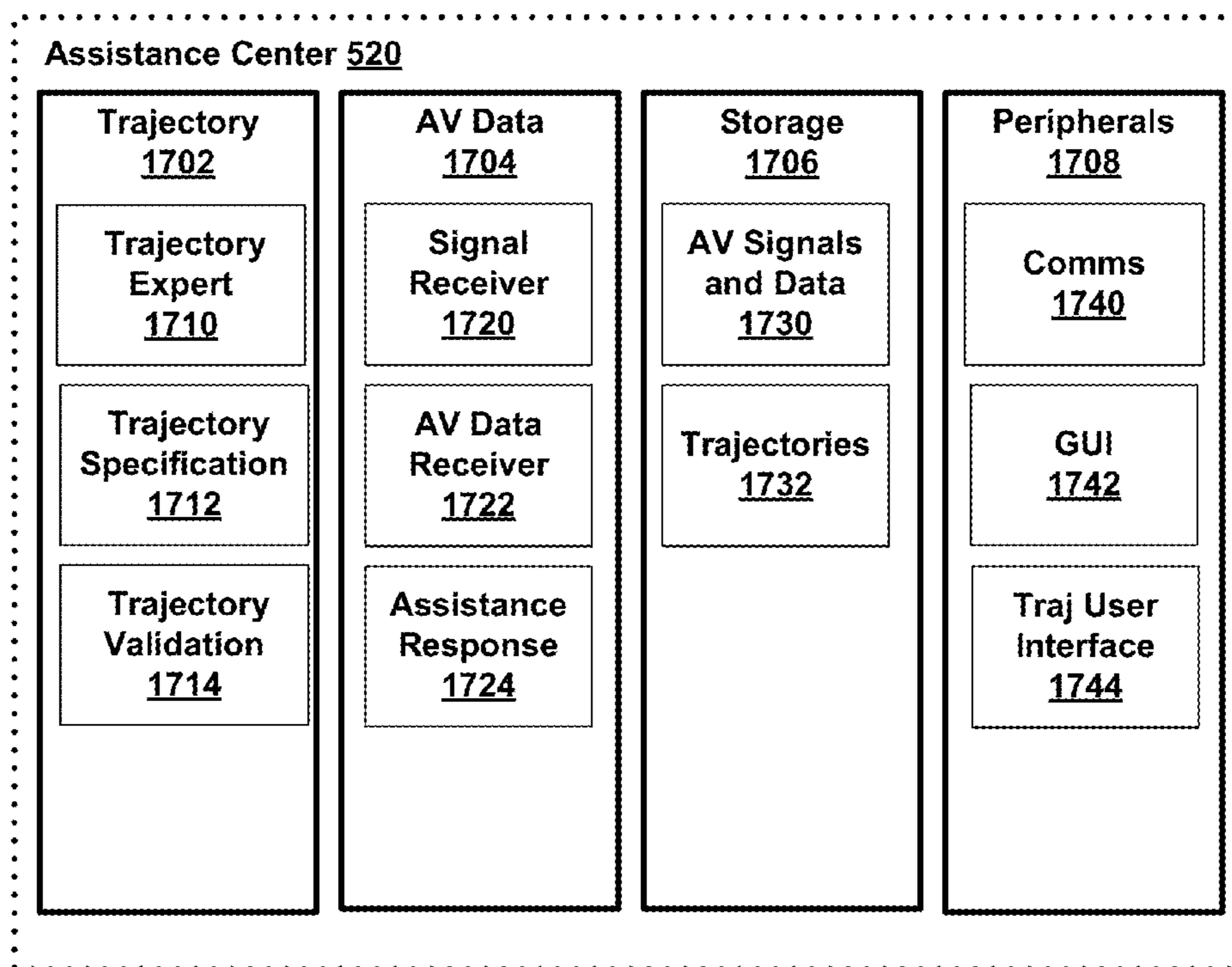

FIG. 17

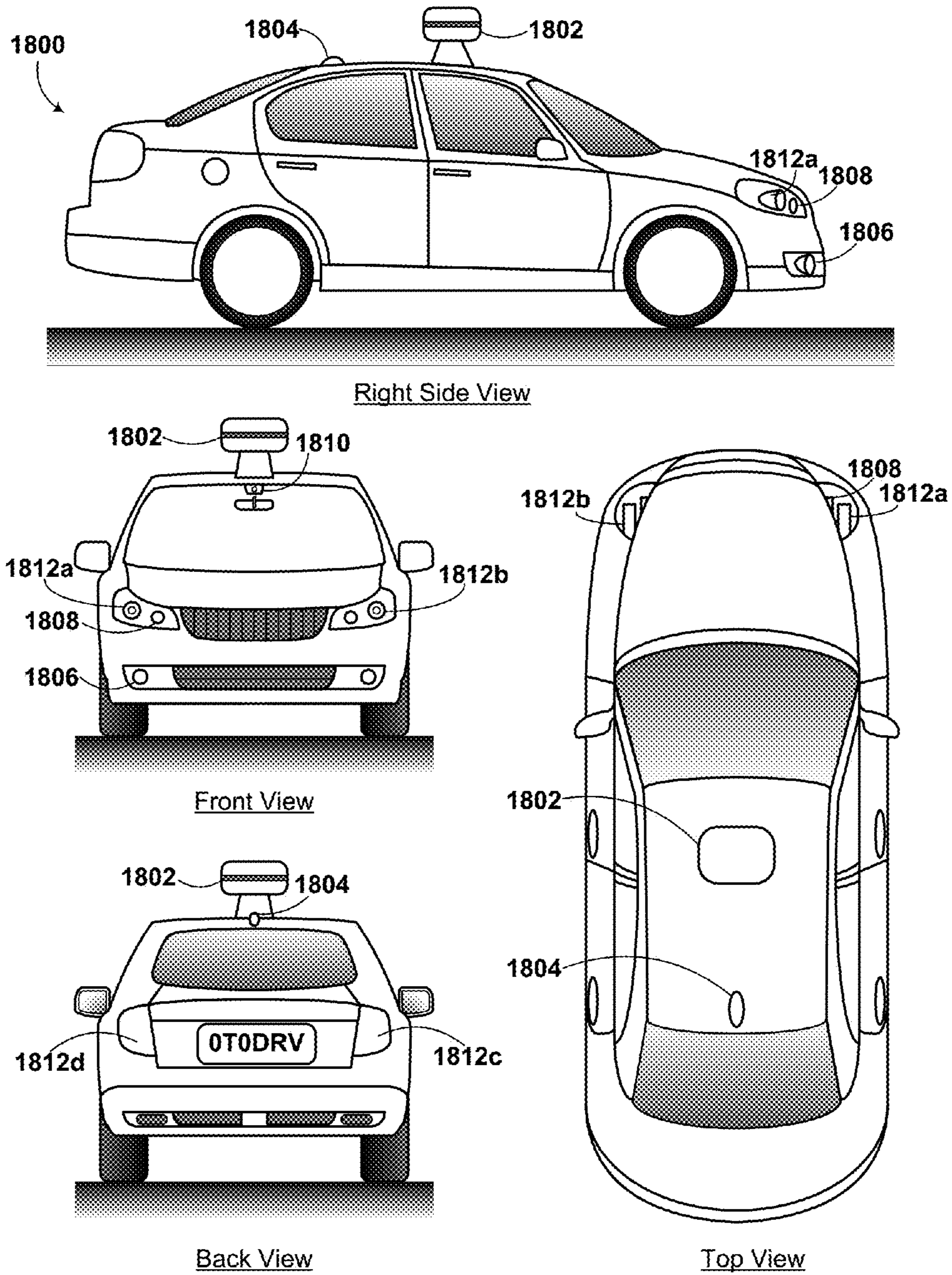

FIG. 18

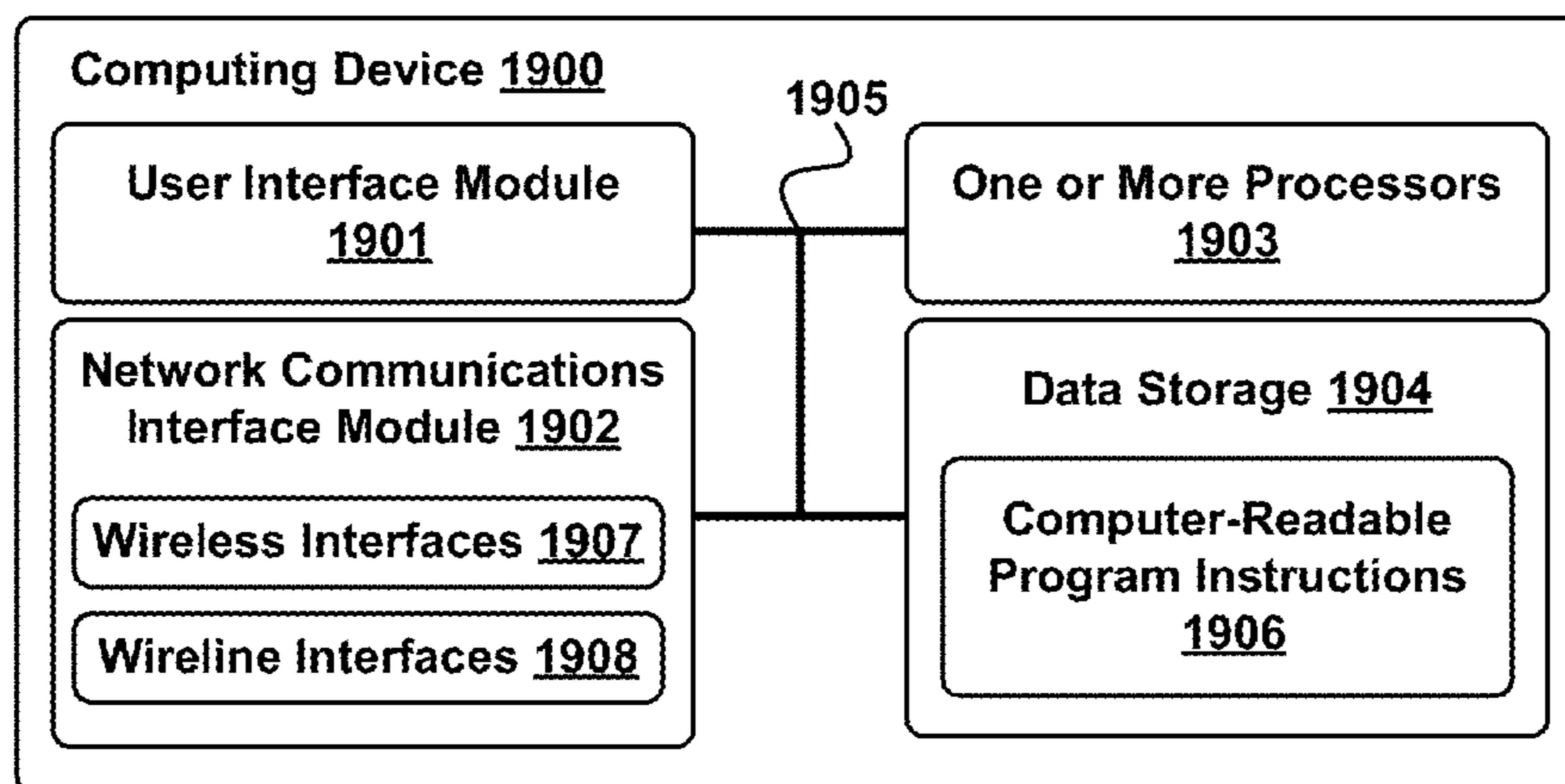

FIG. 19A

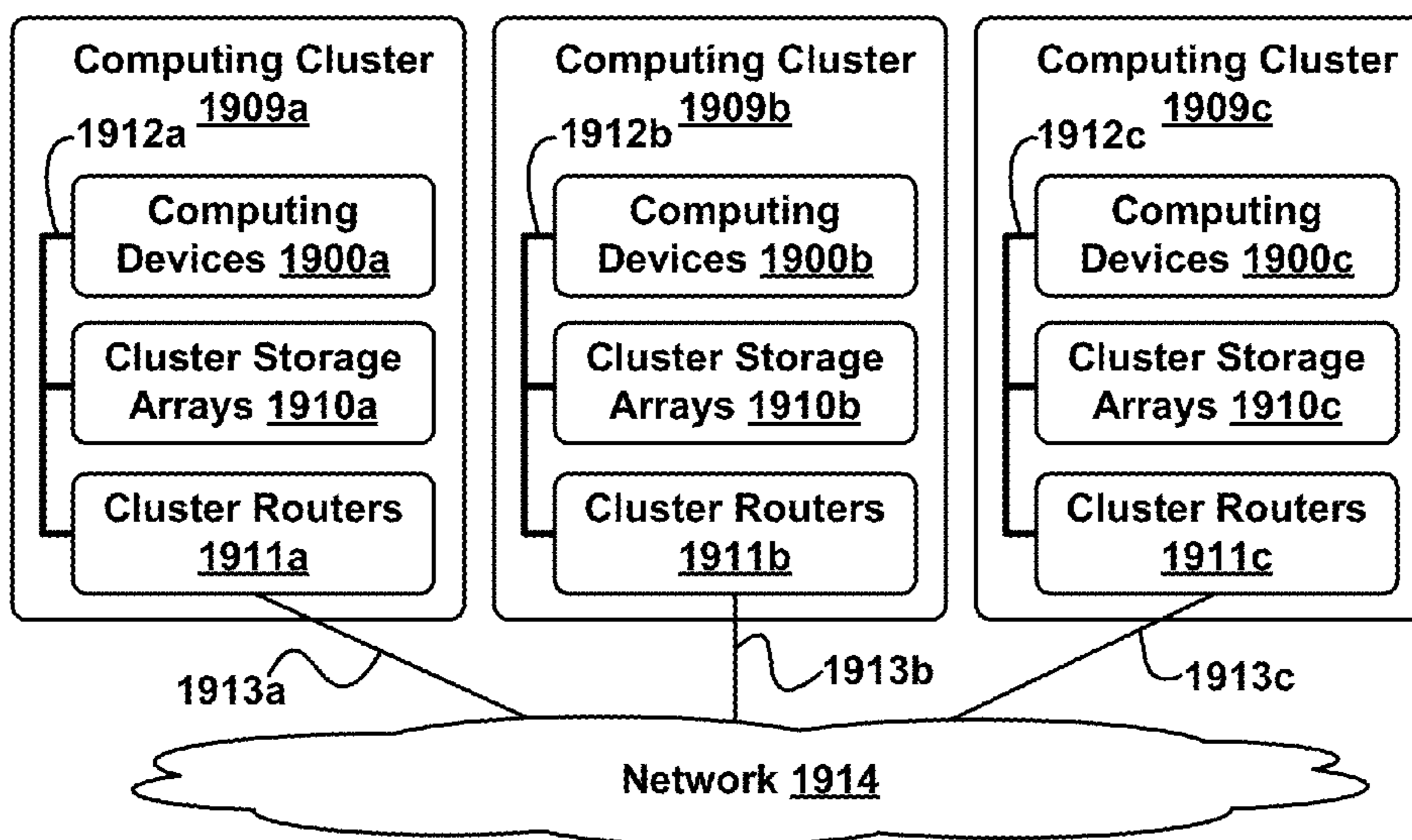

FIG. 19B

AUGMENTED TRAJECTORIES FOR AUTONOMOUS VEHICLES

CROSS-REFERENCE TO RELATED APPLICATIONS

This application claims priority to U.S. patent application Ser. No. 14/679,471, filed Apr. 6, 2015, which is hereby incorporated by reference in its entirety. U.S. patent application Ser. No. 14/679,471 claims priority to U.S. Pat. No. 9,008,890, issued Apr. 14, 2015, which is hereby incorporated by reference in its entirety.

BACKGROUND

Some vehicles are configured to operate in an autonomous mode in which the vehicle navigates through an environment with little or no input from a driver. Such an autonomous vehicle (or AV) typically includes one or more sensors that are configured to sense information about the environment. The autonomous vehicle may use the sensed information to navigate through the environment. For example, if the sensors determine that the autonomous vehicle is approaching an obstacle, the vehicle may be able to navigate around the obstacle. An autonomous vehicle may operate in various weather and lighting conditions, such as, but not limited to, days, nights, good visibility conditions, and/or reduced visibility conditions.

SUMMARY

In one aspect, a system is provided. The system may include an autonomous vehicle and an assistance center. The autonomous vehicle may include a stuck condition detection component and a communications component. The stuck condition detection component may be configured to detect a condition in which the autonomous vehicle is impeded from navigating according to a first trajectory. The communications component may be configured at least to send an assistance signal indicating that the autonomous vehicle seeks assistance navigating according to the first trajectory, and to receive a response to the assistance signal. The assistance signal may include sensor information of the autonomous vehicle, indicating low-level sensor strike input and high-level, polygonal or polyhedral representations of objects in the vicinity of the autonomous vehicle. The assistance center may include a communications component and a trajectory specification component. The communications component may be configured at least to receive the assistance signal, and to send the response to the assistance signal. The trajectory specification component may be configured to specify a second trajectory for the autonomous vehicle and to generate the response to the assistance signal including a representation of the second trajectory. The second trajectory may be based on the first trajectory. The second trajectory may ignore the presence of at least part of one high-level, polygonal or polyhedral representation of an object that obstructs the first trajectory.

In another aspect, a method is provided. An autonomous vehicle may detect a condition in which the autonomous vehicle is impeded from navigating according to a first trajectory. The autonomous vehicle may send, to an assistance center, an assistance signal that the autonomous vehicle seeks assistance navigating according to the first trajectory. The assistance signal may include sensor information of the autonomous vehicle indicating low-level sensor strike input and high-level, polygonal or polyhedral

representations of objects in the vicinity of the autonomous vehicle. The autonomous vehicle may receive a response to the assistance signal. The response may include a representation of a second trajectory, where the second trajectory is based on the first trajectory. The second trajectory may ignore the presence of at least part of one high-level, polygonal or polyhedral representation of an object that obstructs the first trajectory.

In another aspect, an autonomous vehicle is provided. The autonomous vehicle may include one or more processors and a non-transitory computer readable medium storing instructions that, when executed by the one or more processors, cause the autonomous vehicle to perform functions. The functions may include detecting a condition in which the autonomous vehicle is impeded from navigating according to a first trajectory. The functions may also include sending an assistance signal, from the autonomous vehicle to an assistance center, that the autonomous vehicle seeks assistance navigating according to the first trajectory. The assistance signal may include sensor information of the autonomous vehicle indicating low-level sensor strike input and high-level, polygonal or polyhedral representations of objects in the vicinity of the autonomous vehicle. The functions may also include receiving a response to the assistance signal. The response may include a representation of a second trajectory that could be based on the first trajectory. The second trajectory may ignore the presence of at least part of one high-level, polygonal or polyhedral representation of an object that obstructs the first trajectory.

In another aspect, a device is provided. The device may include means for detecting a condition in which navigation according to a first trajectory is impeded, and means for sending an assistance signal to an assistance center seeking assistance to navigate according to the first trajectory. The assistance signal may include sensor information indicating low-level sensor strike input and high-level, polygonal or polyhedral representations of objects in the vicinity of the device. The device may also include means for receiving a response to the assistance signal from the assistance center. The response may include a representation of a second trajectory, where the second trajectory may be based on the first trajectory, and where the second trajectory may ignore the presence of at least part of one high-level, polygonal or polyhedral representation of an object that obstructs the first trajectory.

In another aspect, a method is provided. It may be determined that a speed of an autonomous vehicle is less than or equal to a threshold speed, and that the autonomous vehicle has not detected a traffic control signal. A cause C may be identified for the speed to be less than or equal to the threshold speed. A timer T may be started, where the timer T may be based on the cause C. After the timer T expires, it may be determined whether the cause C remains for the speed to be less than or equal to the threshold speed. After determining that the cause C remains for the speed to be less than or equal to the threshold speed, an assistance signal may be sent by the autonomous vehicle indicating that the autonomous vehicle is stuck.

In another aspect, an autonomous vehicle is provided. The autonomous vehicle may include one or more processors and data storage storing program instructions that, when executed by the one or more processors, cause the autonomous vehicle to perform functions. The functions may include determining that a speed is less than or equal to a threshold speed and that a traffic control signal has not been detected. The functions may also include identifying a cause C for the speed to be less than or equal to the threshold

3

speed, and starting a timer T. The functions may further include, after the timer T expires, determining whether the cause C remains for the speed to be less than or equal to the threshold speed, and, after determining that the cause C remains for the speed to be less than or equal to the threshold speed, sending an assistance signal indicating that the autonomous vehicle is stuck. The timer T may be based on the cause C.

In another aspect, a non-transitory computer readable medium is provided. The non-transitory computer readable medium may store instructions thereon that, when executed by one or more processors, cause the one or more processors to perform functions. The functions may include determining that a speed is less than or equal to a threshold speed, and that a traffic control signal has not been detected. The functions may also include identifying a cause C for the speed to be less than or equal to the threshold speed, and starting a timer T. The functions may further include, after the timer T expires, determining whether the cause C remains for the speed to be less than or equal to the threshold speed, and, after determining that the cause C remains for the speed to be less than or equal to the threshold speed, sending an assistance signal indicating that an autonomous vehicle is stuck. The timer T may be based on the cause C.

In another aspect, a device is provided. The device may include means for determining that a speed is less than or equal to a threshold speed and that a traffic control signal has not been detected. The device may also include means for identifying a cause C for the speed to be less than or equal to the threshold speed, and means for starting a timer T. The device may further include means for, after the timer T expires, determining whether the cause C remains as a cause for the speed to be less than or equal to the threshold speed, and means for, after determining that the cause C remains the cause for the speed to be less than or equal to the threshold speed, sending an assistance signal indicating that the device is stuck. The timer T may be based on the cause C.

In another aspect, a method is provided. An autonomous vehicle may determine to seek assistance to navigate in accordance with a first trajectory. The autonomous vehicle may be configured to receive and store data about a plurality of obstacles. A particular obstacle in the plurality of obstacles may partially or wholly obstruct the first trajectory. The autonomous vehicle may select a portion of the stored data, where the portion of the stored data is less than the totality of the stored data and includes data representing the particular obstacle. The portion of the stored data may be provided to an assistance center. A second trajectory may be received from the assistance center, where the second trajectory is not obstructed by the particular obstacle.

In another aspect, an autonomous vehicle is provided. The autonomous vehicle include one or more processors and data storage storing program instructions thereon that, when executed by the one or more processors, cause the autonomous vehicle to perform functions. The functions may include determining to seek assistance to navigate in accordance with a first trajectory. The data storage may be configured to receive and store data about a plurality of obstacles, and a particular obstacle in the plurality of obstacles may partially or wholly obstruct the first trajectory. The functions may also include selecting a portion of the stored data. The selected portion of the stored data may be less than the totality of the stored data and may include data representing the particular obstacle. The functions may further include providing, to an assistance center, the portion of the stored data, and receiving, from the assistance center,

4

a second trajectory. The second trajectory might not be obstructed by the particular obstacle.

In another aspect, a non-transitory computer readable medium is provided. The non-transitory computer readable medium may store instructions thereon that, when executed by one or more processors, cause the one or more processors to perform functions. The functions may include determining to seek assistance to navigate an autonomous vehicle in accordance with a first trajectory. The autonomous vehicle may be configured to receive and store data about a plurality of obstacles, and a particular obstacle in the plurality of obstacles may partially or wholly obstruct the first trajectory. The functions may include selecting a portion of the stored data. The selected portion of the stored data may be less than the totality of the stored data and may include data representing the particular obstacle. The functions may further include providing, to an assistance center, the portion of the stored data, and receiving, from the assistance center, a second trajectory. The second trajectory might not be obstructed by the particular obstacle.

In another aspect, a device is provided. The device may include means for determining to seek assistance to navigate an autonomous vehicle in accordance with a first trajectory. The autonomous vehicle may be configured to receive and store data about a plurality of obstacles, and a particular obstacle in the plurality of obstacles may partially or wholly obstruct the first trajectory. The device may also include means for selecting a portion of the stored data. The selected portion of the stored data may be less than the totality of the stored data and may include data representing the particular obstacle. The device may further include means for providing, to an assistance center, the portion of the stored data, and means for receiving, from the assistance center, a second trajectory. The second trajectory might not be obstructed by the particular obstacle.

In another aspect, a method is provided. An assistance center may receive a representation of a first trajectory of an autonomous vehicle that is in a stuck condition, where the first trajectory does not relieve the stuck condition. The assistance center may receive sensor information of the autonomous vehicle, where the sensor information may include low-level sensor strike input and high-level, polygonal or polyhedral representations of objects in the vicinity of the autonomous vehicle. The high-level, polygonal or polyhedral representations of objects may be based, at least in part, on the low-level sensor strike input. Based on the first trajectory and the sensor information, the assistance center may determine a second trajectory that relieves the stuck condition while adhering to at least some navigational constraints. Relieving the stuck condition may include ignoring at least one high-level, polygonal or polyhedral representation of an object that obstructs the first trajectory. The assistance center may transmit a representation of the second trajectory and instructions for the autonomous vehicle to drive in accordance with the second trajectory.

In another aspect, a non-transitory computer readable medium is provided. The non-transitory computer readable medium may store instructions thereon that, when executed by a computing device, cause the computing device to perform functions. The functions may include receiving a representation of a first trajectory of an autonomous vehicle that is in a stuck condition. The first trajectory might not relieve the stuck condition. The functions may also include receiving sensor information of the autonomous vehicle, where the sensor information may include low-level sensor strike input and high-level, polygonal or polyhedral representations of objects in the vicinity of the autonomous

5

vehicle. The high-level, polygonal or polyhedral representations of objects may be based, at least in part, on the low-level sensor strike input. The functions may further include, based on the first trajectory and the sensor information, determining a second trajectory that may relieve the stuck condition while adhering to at least some navigational constraints. Relieving the stuck condition may include ignoring at least one high-level, polygonal or polyhedral representation of an object that obstructs the first trajectory. The functions may additionally include transmitting a representation of the second trajectory and instructions for the autonomous vehicle to drive in accordance with the second trajectory.

In another aspect, a device is provided. The device may include means for receiving a representation of a first trajectory of an autonomous vehicle that is in a stuck condition. The first trajectory might not relieve the stuck condition. The device may also include means for receiving sensor information of the autonomous vehicle, where the sensor information may include low-level sensor strike input and high-level, polygonal or polyhedral representations of objects in the vicinity of the autonomous vehicle. The high-level, polygonal or polyhedral representations of objects may be based, at least in part, on the low-level sensor strike input. The device may also include means for determining a second trajectory, based on the first trajectory and the sensor information, which relieves the stuck condition while adhering to at least some navigational constraints. Relieving the stuck condition may include ignoring at least one high-level, polygonal or polyhedral representation of an object that obstructs the first trajectory. The device may additionally include means for transmitting a representation of the second trajectory and instructions for the autonomous vehicle to drive in accordance with the second trajectory.

The foregoing summary is illustrative only and is not intended to be in any way limiting. In addition to the illustrative aspects, appearances, embodiments, and features described above, further aspects, appearances, embodiments, and features will become apparent by reference to the figures and the following detailed description.

BRIEF DESCRIPTION OF THE DRAWINGS

FIG. 1 is a flow chart of an example method, according to an example embodiment.

FIG. 2 is a flow chart of another example method, according to an example embodiment.

FIG. 3 is a flow chart of yet another example method, according to an example embodiment.

FIG. 4 is a flow chart of still another example method, according to an example embodiment.

FIG. 5 shows an example autonomous vehicle operating environment, according to an example embodiment.

FIG. 6 shows a scenario where an autonomous vehicle is in a stuck condition, according to an example embodiment.

FIG. 7 is a flow chart of an example method for detecting whether an autonomous vehicle is in a stuck condition, according to an example embodiment.

FIG. 8 shows an example scenario where an autonomous vehicle is attempting to follow an original trajectory to destination, according to an example embodiment.

FIG. 9 shows another example scenario where an autonomous vehicle is attempting to follow an original trajectory to destination, according to an example embodiment.

6

FIG. 10 is a flow chart of an example method where an autonomous vehicle requests assistance from an assistance center to relieve a stuck condition, according to an example embodiment.

FIG. 11 schematically illustrates a LIDAR unit scanning across an obstacle-filled environmental scene, according to an example embodiment.

FIG. 12 schematically illustrates an example point cloud corresponding to the obstacle-filled environmental scene of FIG. 11.

FIG. 13 schematically illustrates spatial point data indicative of a surface of a target vehicle that is stationary relative to a LIDAR unit, according to an example embodiment.

FIG. 14 schematically illustrates spatial point data indicative of a surface of a target vehicle that is moving relative to a LIDAR unit, according to an example embodiment.

FIGS. 15A, 15B, and 15C show a scenario for using a trajectory interface to relieve a stuck condition of an autonomous vehicle, according to example embodiments.

FIG. 16 is a functional block diagram illustrating an autonomous vehicle, according to an example embodiment.

FIG. 17 is a functional block diagram illustrating an assistance center, according to an example embodiment.

FIG. 18 shows a vehicle that may be similar or identical to the vehicle described with respect to FIG. 16, according to an example embodiment.

FIG. 19A is a block diagram of a computing device, according to an example embodiment.

FIG. 19B depicts a network of computing clusters arranged as a server system, according to an example embodiment.

DETAILED DESCRIPTION

Autonomous vehicles may navigate by using a number of sensors to collect information about objects in the vicinity of the autonomous vehicle, and by determining trajectories for the autonomous vehicle based on this collected information. For instance, an autonomous vehicle may be equipped with one or more video cameras, still cameras, radar units, Light Detection and Ranging (LIDAR) units, Global Positioning System (GPS) units, and/or perhaps other types of location-determining or object-detection technologies.

For instance, the autonomous vehicle may be configured with a LIDAR unit to generate the low-level data about nearby environmental features. The LIDAR unit may estimate distances to these environmental features while scanning through the surroundings of the autonomous vehicle. Thus, the LIDAR unit may assemble a cloud of point positions indicative of the three-dimensional shapes of objects in the surroundings. Individual points may be measured by generating a laser pulse and detecting a returning pulse, if any, reflected from an environmental object, and determining the distance to the reflective object according to the time delay between the emitted pulse and the reception of the reflected pulse.

The laser, or set of lasers, may be rapidly and repeatedly scanned across the surroundings to provide continuous, or nearly continuous, real-time information on distances to the objects therein. Combining the measured distances, and the orientation of the laser(s) while measuring each distance, allows for associating a three-dimensional position with each returning pulse. In this way, a three-dimensional map of points of reflective features can be generated based on the returning pulses for the entire scanning zone. Using the three-dimensional point map, high-level data defining the relative sizes, shapes, velocities, and trajectories of various

objects (such as other vehicles, pedestrians, trees, structures, etc.) can be inferred. These objects may be represented as polygons or polyhedrons, or by other two-dimensional or three-dimensional representations.

From this information, as well as possible navigational requests from one or more users or controllers of the autonomous vehicle, the autonomous vehicle may develop a trajectory that it can drive from a starting point (e.g., the autonomous vehicle's current location) to an endpoint (e.g., a destination). The trajectory may also specify some number of intermediate waypoints through which the autonomous vehicle should pass while navigating from the starting point to the endpoint.

While driving in accordance with such a trajectory, the autonomous vehicle may adhere to navigational constraints. For instance, the autonomous vehicle may take steps to avoid collisions, to avoid breaking traffic laws (e.g., staying in the proper lane, obeying the speed limit, and stopping fully at stop signs), and to avoid causing inertial discomfort to passengers (e.g., rapid acceleration or deceleration, sudden turns, and so on) unless absolutely necessary. The autonomous vehicle may make use of low-level and high-level sensor information in order to adhere to these constraints. Thus, for example, if the autonomous vehicle detects an obstacle in its trajectory, it may make modifications to the trajectory in order to avoid the obstacle.

In some scenarios, an autonomous vehicle may enter into a "stuck" condition. The stuck condition may be, for instance, a condition where the autonomous vehicle might not be able to navigate in accordance with an original trajectory without relaxing any of its navigational constraints. For example, an autonomous vehicle may be configured with constraint(s) to "stay on the road" and "do not back up while on the road." Then, while driving, the autonomous vehicle may determine that the road ahead is completely obstructed by a large object. Even if a shoulder of the road and/or the road behind the autonomous vehicle is clear, the autonomous vehicle may not be able to navigate around or away from the large object. Thus, the autonomous vehicle may determine that it is in a stuck condition.

Detecting when the autonomous vehicle is stuck may be a complex problem. Some approaches may generate an excessive number of false positive results. This may lead to over-allocation of resources to assist stuck autonomous vehicles. Other approaches lead to excessive amount of waiting until the autonomous vehicle determines that it is in a stuck condition.

As an example, consider a heuristic of setting a timer whenever the autonomous vehicle stops, and alerting when the stoppage lasts longer than a threshold N seconds. If the threshold N is set to 5 seconds, alerts may be sent while waiting for stop lights, when the autonomous vehicle is in stop and go freeway traffic, and when the autonomous vehicle is navigating stop signs at busy intersections. These alerts are likely to be considered false positives. On the other hand, if N is set to 600 seconds (10 minutes), the autonomous vehicle may wait behind a double parked car on an otherwise empty street for at least 10 minutes. In this situation, the waiting may result in a poor user experience.

Upon determining that the autonomous vehicle is in a stuck condition, the autonomous vehicle may send an assistance request to an assistance center to request assistance. This assistance request may include the location of the autonomous vehicle, as well as some basic data from one or more of the autonomous vehicle's sensors. In response, the assistance center may either accept or reject the assistance

request. If the request is accepted, the assistance center may send a new trajectory for use by the autonomous vehicle.

In some cases, in order to provide the navigational assistance, the assistance center may determine that it would benefit from additional data from the autonomous vehicle. The additional data may include data that is too expensive or burdensome for the autonomous vehicle to transmit to the assistance center by default. Low-level data, such as clusters of laser strikes on surfaces in the vicinity of the autonomous vehicle, may be useful to the assistance center. For example, the laser strike data is generally more accurate than high-level object data that may be, at least partially, inferred from the laser strike data.

The low-level data may be useful to an expert in the assistance center, such as a human expert and/or an expert system. However, the autonomous vehicle may generate a large enough volume of low-level data to be impractical for the autonomous vehicle to regularly transmit. Instead, the autonomous vehicle may use heuristics to reduce the extent of transmitted data, such as but not limited to restricting the number of obstacles or objects to report based on proximity to the autonomous vehicle, sorting objects based on the autonomous vehicle's trajectory or location or perceived importance of the objects, and/or preferring expert-friendly types of data for transmission. Additionally, or alternatively, the autonomous vehicle may restrict the data to high-level (e.g., polygonal or polyhedral) representations of these objects that were derived from the low-level data.

Being able to determine when an autonomous vehicle is stuck and then when to request assistance may significantly reduce the extent of experts used to operate a fleet of autonomous vehicles. Such an expert, for instance as a human or an expert system, may be at an assistance center waiting for assistance requests. As such, one expert at an assistance center may assist multiple autonomous vehicles. Thus, if stuck conditions can be efficiently and effectively detected, experts may be freed up for other tasks and the operating costs of autonomous vehicles may be reduced.

Turning to the figures, FIG. 1 is a flow chart of method 100, according to an example embodiment. Method 100 may be carried out by an autonomous vehicle, such as described below in the context of at least FIGS. 16 and 18.

At block 110, an autonomous vehicle may detect a condition in which the autonomous vehicle is impeded from navigating according to a first trajectory, such as discussed below in the context of at least FIGS. 6 and 7.

At block 120, the autonomous vehicle may send an assistance signal to an assistance center, such as discussed below in the context of at least FIGS. 8-10 and 15A-15C. The assistance signal may indicate that the autonomous vehicle seeks assistance navigating according to the first trajectory. The assistance signal may include sensor information of the autonomous vehicle. The sensor information may indicate low-level sensor strike input, such as laser strike input discussed below in the context of FIGS. 11-14, and/or high-level, polygonal or polyhedral representations of objects in the vicinity of the autonomous vehicle, such as discussed previously, as well as below in the context of FIGS. 11-15C.

At block 130, the autonomous vehicle may receive a response to the assistance signal, such as discussed below in the context of at least FIGS. 8-10 and 15A-15C. The response may include a representation of a second trajectory, where the second trajectory may be based on the first trajectory. The second trajectory may ignore the presence of at least part of one high-level, polygonal or polyhedral representation of an object that obstructs the first trajectory,

such as discussed below at least in the context of FIGS. 5, 8-10, 15A-15C, and 17. For example, an expert at the assistance center may have determined that the object does not fully obstruct the first trajectory, and therefore may be at least partially ignored.

In some embodiments, the second trajectory may include a path defined by a plurality of points. The path defined by the plurality of points may include a spline connecting at least two points in the plurality of points.

Method 100 may include determining the second trajectory using an expert entity at the assistance center. The second trajectory may be determined based on the assistance signal and the sensor information. In some embodiments, the expert entity may include a human expert. In other embodiments, the expert entity may include a computing system.

In further embodiments, method 100 may include the autonomous vehicle obtaining the second trajectory from the response, and driving according to the second trajectory. Driving the autonomous vehicle according to the second trajectory may include driving according to the first trajectory after driving according to the second trajectory. For instance, the second trajectory may avoid one or more obstacles, and then may lead back to the first trajectory. In some cases, the autonomous vehicle may validate the second trajectory prior to driving according to the second trajectory.

FIG. 2 is a flow chart of method 200, according to an example embodiment. Method 200 may be carried out by an autonomous vehicle, such as described below in the context of at least FIGS. 16 and 18.

At block 210, a determination may be made that a speed of an autonomous vehicle is less than or equal to a threshold speed and that the autonomous vehicle has not detected a traffic control signal, such as discussed below in more detail in the context of at least FIGS. 6 and 7. In some embodiments, determining that the speed of the autonomous vehicle is less than or equal to the threshold speed may include determining that the autonomous vehicle is not increasing speed. The traffic control signal may include be a stop sign signal, a stop light signal, a warning sign signal, and a warning light signal. The threshold speed may be between zero and one meter per second, between zero and three meters per second, between zero and five meters per second, and so on.

At block 220, a cause C may be identified for the speed to be less than or equal to the threshold speed, such as discussed below in more detail in the context of at least FIG. 7. In some embodiments, the cause C may be based on a pedestrian, based on a vehicle other than the autonomous vehicle, and/or based on another type of object. The cause C may obstruct a trajectory of the autonomous vehicle.

At block 230, a timer T that is based on the cause C may be started, such as discussed below in more detail in the context of at least FIG. 7. At block 240, after the timer T expires, a determination may be made whether the speed is still less than or equal to the threshold speed and/or the cause C remains as a cause for the speed to be less than or equal to the threshold speed, such as discussed below in more detail in the context of at least FIG. 7. If this is the case, then, at block 250, an assistance signal indicating that the autonomous vehicle is stuck may be sent from the autonomous vehicle, such as discussed below in more detail in the context of at least FIG. 7.

In some embodiments, method 200 may further include, after sending the assistance signal, determining that the speed of the autonomous vehicle is greater than the threshold speed. Then, based on determining that the speed of the autonomous vehicle is greater than the threshold speed, a

determination may be made that the autonomous vehicle is no longer stuck. In this case, the autonomous vehicle may no longer seek out assistance, and may transmit a message to the assistance center indicating that the request for assistance is cancelled.

Method 200 may also include the autonomous vehicle receiving a response to the assistance signal, where the response specifies a second trajectory for the autonomous vehicle, and navigating according to the second trajectory. The second trajectory may avoid the obstruction of cause C. In particular embodiments, method 200 may further include, after navigating according to the second trajectory, determining that the autonomous vehicle may safely return to navigating according to the trajectory. In response to determining that the autonomous vehicle may return to navigating according to the trajectory, the autonomous vehicle may switch from navigating according to the second trajectory to navigating according to the trajectory.

FIG. 3 is a flow chart of method 300, according to an example embodiment. Method 300 may be carried out by an autonomous vehicle, such as described below in the context of at least FIGS. 16 and 18.

At block 310, the autonomous vehicle may determine to seek assistance to navigate in accordance with a first trajectory. The autonomous vehicle may be configured to receive and store data about a plurality of obstacles. A particular obstacle in the plurality of obstacles may partially or wholly obstruct the first trajectory, such as discussed below in the context of at least FIGS. 5-17. In some embodiments, the stored data may include sensor data about the plurality of obstacles, where the sensor data may comprise representations of distances between the autonomous vehicle and at least some obstacles in the plurality of obstacles, such as discussed below in the context of at least FIGS. 10-15C.

In full generality, one or more particular obstacles may obstruct the first trajectory. For instance, the autonomous vehicle may determine that two, three, or more obstacles are obstructing its trajectory. The autonomous vehicle may take action, in accordance with method 300 and/or any other embodiment herein, to navigate around or otherwise avoid these obstacles. However, for sake of simplicity, some examples herein discuss such processes in the context of a single obstacle.

At block 320, the autonomous vehicle may select a portion of the stored data. The selected portion of the stored data may be less than the totality of the stored data and may include data representing the particular obstacle, such as discussed below in the context of at least FIGS. 10 and 15A-15C. In some embodiments, the stored data may include video data about the plurality of obstacles. Then, selecting the portion of the stored data may include selecting at least some of the video data, such as discussed below in the context of at least FIGS. 8, 10, and 15A-15C.

Selecting the portion of the stored data may include determining a threshold distance D. Then, for each obstacle O1 in the plurality of obstacles, a distance D1 between the obstacle O1 and the autonomous vehicle may be determined. A further determination may be made whether the threshold distance D is greater than the distance D1. If the threshold distance D is greater than the distance D1, the obstacle O1 may be identified as a candidate obstacle for the portion of the stored data. In particular embodiments, selecting the portion of the stored data may include selecting stored data for each candidate obstacle.

In some embodiments, selecting the portion of the stored data additionally may include making a determination of a number N of obstacles in the plurality of obstacles, where

$N > 0$. Then, for each candidate obstacle **O2** in the plurality of obstacles, a determination may be made whether the candidate obstacle **O2** is one of N obstacles closest to the autonomous vehicle. If the candidate obstacle **O2** is one of the number N obstacles closest to the autonomous vehicle, stored data about the candidate obstacle **O2** may be selected.

In further embodiments, selecting the portion of the stored data about the plurality of obstacles may include determining a threshold distance **D2**. Then, for each obstacle **O1** in the plurality of obstacles, a determination may be made of a closest distance value **D3** between the obstacle **O1** and a closest point on the original trajectory to **O1**. The plurality of obstacles may be sorted based on the closest distance values **D3**. Stored data about for obstacles with a closest distance value **D3** less than the threshold distance **D2** may be selected.

At block **330**, the portion of the stored data may be provided to an assistance center, such as discussed below in the context of at least FIGS. **10** and **15A-15C**. In some embodiments, providing the portion of the stored data may include transmitting a request for navigational assistance, receiving a request for information regarding obstacles, and transmitting the portion of the stored data, such as discussed below in the context of at least FIG. **10**. This communication may take place between the autonomous vehicle and the assistance center.

At block **340**, a second trajectory may be received from the assistance center. The second trajectory might not be obstructed by the particular obstacle, such as discussed below in the context of at least FIGS. **8-10** and **15A-15C**. In some embodiments, the second trajectory may meet the first trajectory at two or more points.

FIG. **4** is a flow chart of method **400**, according to an example embodiment. Method **400** may be carried out by an assistance center, such as described below in the context of at least FIG. **17**.

At block **410**, the assistance center may receive a representation of a first trajectory of an autonomous vehicle that is in a stuck condition. The first trajectory might not relieve the stuck condition, such as discussed below in the context of at least FIGS. **8-10** and **15A-15C**.

At block **420**, the assistance center may receive sensor information of the autonomous vehicle, where the sensor information may include low-level sensor strike input and high-level, polygonal or polyhedral representations of objects in the vicinity of the autonomous vehicle. The high-level, polygonal or polyhedral representations of objects may be based at least in part on the low-level sensor strike input, such as discussed below in the context of at least FIGS. **8-10** and **15A-15C**.

At block **430**, the assistance center may, based on the first trajectory and the sensor information, determine a second trajectory that relieves the stuck condition while adhering to at least some navigational constraints. These navigational constraints may include, for instance, the autonomous vehicle avoiding collisions, obeying traffic laws, and/or not causing inertial discomfort to its passengers. Relieving the stuck condition may include ignoring at least one high-level, polygonal or polyhedral representation of an object that obstructs the first trajectory, such as discussed below in the context of at least FIGS. **8-10** and **15A-15C**. In some embodiments, the first and second trajectories may be identical.

Determining the second trajectory may include determining that the first trajectory does not relieve the stuck condition. After determining that the first trajectory does not relieve the stuck condition, the second trajectory may be

determined such that the second trajectory is different from the first trajectory and the second trajectory intersects the first trajectory at two or more points.

Alternatively or additionally, determining the second trajectory may include receiving a request for navigational assistance from the autonomous vehicle, transmitting a request for additional information from the assistance center to the autonomous vehicle, and receiving a proposed trajectory from the autonomous vehicle. The second trajectory may be based on the proposed trajectory, and the proposed trajectory may intersect the first trajectory at two or more points. In some of these embodiments, the second trajectory and the proposed trajectory may be identical, perhaps indicating that the assistance center has accepted the proposed trajectory.

In yet other embodiments, the second trajectory may be determined without human interaction. In still other embodiments, the second trajectory may be determined using a computing device at the assistance center, where the computing device is coupled to a graphical user interface configured to display autonomous vehicle trajectories, and where at least some of the second trajectory may be defined using the graphical user interface.

Method **400** may further include determining that the proposed trajectory relieves the stuck condition. Method **400** may additionally include determining that the proposed trajectory does not relieve the stuck condition, and modifying the proposed trajectory so that the modified proposed trajectory relieves the stuck condition. In these cases, the second trajectory may be the modified proposed trajectory.

At block **440**, the assistance center may transmit a representation of the second trajectory and instructions for the autonomous vehicle to drive in accordance with the second trajectory, such as discussed below in the context of at least FIGS. **8-10** and **15A-15C**.

In embodiments where the second trajectory is determined using a computing device at the assistance center, method **400** may further include estimating a network data rate between the autonomous vehicle and the computing device and requesting that the autonomous vehicle transmit location and sensor information to the assistance center such that the estimated data rate is not exceeded. This may involve estimating, or otherwise determining a maximum network data rate between the autonomous vehicle and the computing device and controlling the actual data rate between autonomous vehicle and the computing device so that it is no greater than the maximum data rate.

To that point, FIG. **5** shows an example autonomous vehicle operating environment **500** with a number of autonomous vehicles **510**, **512**, **514** in communication with assistance center **520** via network **522**. In some embodiments, some or all of autonomous vehicles **510**, **512**, **514** may be capable of communicating with assistance center **520**. Network **522** may include one or more networks, such as, but not limited to, one or more wireless wide area networks (WWANs) and/or wireless local area networks (WLANs). Each of autonomous vehicles **510**, **512**, **514** may be configured with a communication component at least for communicating with assistance center **520** and network **522**. Also, assistance center **520** may be configured with a communications component for communicating with one or more of autonomous vehicles **510**, **512**, **514** and network **522**. In some embodiments, some or all functions of assistance center **520** may be performed in an autonomous vehicle, perhaps by a human rider or driver.

FIG. **6** shows an example scenario **600** where an autonomous vehicle **610** is attempting to drive on road **602** accord-

ing to original trajectory **630** to destination **632**. However, autonomous vehicle **610** is in a stuck condition because original trajectory **630** is blocked by vehicle **614**. Thus, navigation according to original trajectory **630** is not possible without adjusting a destination or trajectory of autonomous vehicle **610**. Autonomous vehicle **602** may be configured to be able to drive on a left lane of road **602**. However, in scenario **600**, vehicle **612** blocks that trajectory. In scenario **600**, vehicles **612**, **614**, **616**, and **618** may be stopped or moving at a slow speed.

FIG. 7 shows an example method **700** for detecting whether an autonomous vehicle is in a stuck condition. At block **710**, the autonomous vehicle may determine if it is either increasing speed and/or if a current speed of the autonomous vehicle is greater than a threshold speed of X meters per second (m/s). In some embodiments, X may be specified in dimensions other than meters per second; e.g., miles per hour, kilometers per hour, or feet per second. If the autonomous vehicle is either increasing speed or if the current speed of the autonomous vehicle is greater than X miles per hour, the autonomous vehicle is not stuck. In some cases, the autonomous vehicle may only determine whether its current speed is greater than the threshold speed.

Otherwise, at block **720**, the autonomous vehicle may determine whether it has detected a traffic control signal. The traffic control signal may include a stop sign signal, a stop light signal, a warning sign signal, a warning light signal, yield signal, or some other type of signal that may indicate that the autonomous vehicle should be stopped or operating at a limited speed. If the autonomous vehicle has detected a traffic control signal, the autonomous vehicle is not stuck. Nonetheless, if an autonomous vehicle has been stationary or moving slowly in the presence of a traffic control signal for more than a threshold period of time, the autonomous vehicle may consider itself to be stuck. For instance, the autonomous vehicle may be stopped at a stop sign with its trajectory blocked by another vehicle.

Otherwise, at block **730**, the autonomous vehicle may determine whether it is currently stopped awaiting user input. For example, the autonomous vehicle may be stopped while a user specifies a destination for the autonomous vehicle. If the autonomous vehicle is stopped awaiting user input, the autonomous vehicle is not stuck.

Otherwise, at block **740**, the autonomous vehicle may identify a cause C for the autonomous vehicle not to be increasing speed and/or for the current speed less than or equal to the threshold speed. The cause C may be a cause based on a pedestrian, a cause based on a vehicle other than the autonomous vehicle, or a cause based on a particular type of object or an unknown object.

At block **750**, the autonomous vehicle may set a timer T for T1 seconds, where T1 is based on the cause C. Table 1 below shows an example table of causes and corresponding T1 values.

TABLE 1

Cause	T1
Vehicle	8 seconds
Pedestrian	18 seconds
Unknown object in trajectory	12 seconds

In some embodiments, additional causes to those shown in Table 1 may be identified by the autonomous vehicle, and consequently additional T1 values may be associated with

the additional causes. In some cases, T1 values may differ from those specified in Table 1.

Alternatively or additionally, T1 values may be a function of blockage data for a location, where the autonomous vehicle may be stuck due to the nature of the location. For example, T1 values may be determined using a decision tree such as shown in Table 2 below:

TABLE 2

1. Has the autonomous vehicle traversed this location previously?
a. Yes - have any vehicular obstacles been encountered at this location?
i. Yes - has a vehicular obstacle been reported within a threshold period of time; e.g., 15 minutes?
1. Yes - set T1 = T1 value used for previous obstacle
2. No - set T1 = 10 seconds
ii. No - is the blockage in the curbside lane?
1. Yes - set T1 = 12 seconds.
2. No - set T1 = 15 seconds.
b. No - is the blockage in the curbside lane?
i. Yes - set T1 = 12 seconds.
ii. No - set T1 = 15 seconds.

In even other embodiments, T1 may be specified based on a combination of features including, but not limited to:

a day of week—e.g., useful for taking into account events like street cleaning days, working days, non-working days/holidays;

property usage information—e.g., is the vehicle at or near building(s) where traffic may have fairly regular patterns, such as a school, a university, a factory, a hospital, a stadium or arena, an office campus, etc.;

a time of day—e.g., schools tend to cause more blockages in the morning and early afternoon, factories and hospitals may have increased traffic at shift changing times, arenas may have increased traffic before and after an event; and/or

a number of autonomous vehicles passing through this location per unit time as a measure of congestion.

a number of non-autonomous vehicles passing through this location per unit time as a measure of congestion.

In still other embodiments, T1 may be specified using other units of time than seconds; e.g., tenths of seconds or minutes.

At block **752**, timer T may run for T1 seconds; e.g., timer T may be started by the autonomous vehicle. At block **760**, the autonomous vehicle may wait for timer T to expire; i.e., wait for at least T1 seconds.

At block **770**, the autonomous vehicle may determine whether it is not increasing speed and/or cause C remains as the cause for the autonomous vehicle not to be increasing speed. If cause C does not remain, then the autonomous vehicle is no longer stuck. In some cases, there may be multiple causes for the autonomous vehicle to be stuck. Thus, the autonomous vehicle may examine its environment for another cause, and may attempt to address any further cause in accordance with the techniques described herein.

At block **780**, the autonomous vehicle may determine that it is in a stuck condition and send an alert, such as an assistance signal, to indicate that the autonomous vehicle is stuck. In some embodiments, after completing block **780**, method **700** may restart; e.g., method **700** may proceed to block **710**.

Alternatively or additionally, the autonomous vehicle may process, in parallel, several causes that overlap in time. For instance, if the autonomous vehicle determines that there is another vehicle stopped in front of it and a pedestrian is also crossing the road in front of it, the autonomous vehicle may start two independent timers, one for the other vehicle and

one for the pedestrian. If either timer expires, the autonomous vehicle may determine that it is in a stuck condition.

At block 790, the autonomous vehicle may determine that it is not in a stuck condition. In some embodiments, the autonomous vehicle may send an alert to the assistance center. This alert may be a “clear path” signal, to indicate that the autonomous vehicle is not stuck. In some embodiments, after completing the techniques of block 790, method 700 may restart; e.g., method 700 may proceed to block 710.

FIG. 8 shows an example scenario 800 where an autonomous vehicle 810 is attempting to drive on road 802 following original trajectory 830 to destination 832. However, autonomous vehicle 810 is in a stuck condition since original trajectory 830 is blocked by vehicle 814. In example scenario 800, vehicles 812, 814, 816, and/or 818 may be stopped or moving slowly (e.g., below a threshold speed).

Upon recognizing that it is in the stuck condition, autonomous vehicle 810 may send (perhaps wirelessly) an assistance signal to an assistance center (not shown in FIG. 8) to relieve the stuck condition. The assistance center may accept the assistance signal and request additional data from autonomous vehicle 810. Alternatively, autonomous vehicle 810 may provide the additional data to the assistance center before receiving such a request.

As mentioned above, heuristics may be applied to reduce the volume of data. One heuristic is to organize the obstacles by distance from the autonomous vehicle and/or to cap the number of obstacles to be the O nearest. Doing so may filter out any obstacles more than D meters away. For example, FIG. 8 shows that vehicle 814 is nearest to autonomous vehicle 810, and then vehicle 812, bottles 820, 822, 824, 826, and 828, and then vehicles 816 and 818. In some embodiments, D may be a function of the speed of autonomous vehicle 810; i.e., the faster the speed of autonomous vehicle 810, the larger the distance that should be considered. Thus, D may increase (or decrease) as the speed of autonomous vehicle 810 increases (or decreases).

Another heuristic may involve sorting obstacles by their distance from the nearest point on the trajectory of autonomous vehicle 810. Computing this set of obstacles may provide a more useful view of upcoming obstacles by prioritizing obstacles in the front of autonomous vehicle 810, but deprioritizing obstacles behind or off to the sides of autonomous vehicle 810. For example, with respect to new trajectory 836, FIG. 8 shows that new trajectory 836 comes closest to vehicle 814, then vehicles 816 and 812, bottles 820, 822, 824, 826, and 828, and then vehicle 818.

Even another heuristic is to prefer expert-friendly types of data for transmission. For example, human experts often may quickly analyze a condition of autonomous vehicle 810 using video data, or if video data is unavailable, using recent still images. Autonomous vehicle 810 may preferentially transmit video data (or still images) over other types of data, as this data is more likely to lead to resolution of the stuck condition than other types of data. In addition to these heuristics to reduce transmission load, throttling (i.e., only transmitting data every X seconds, or when there is a meaningful change) may also be used to further reduce load. Some or all of the herein-described heuristics may be used by autonomous vehicle 810 to provide data to the assistance center.

After receiving this data at the assistance center, an expert may propose new trajectory 836, which begins at a current position of autonomous vehicle 810 and finishes at endpoint 838, where new trajectory 836 joins original trajectory 830. (It is assumed that autonomous vehicle 810 can navigate

according to new trajectory 836 without colliding with any objects—thus, FIG. 8, and possibly other figures as well, may not be drawn to scale.)

Upon reaching endpoint 838, autonomous vehicle 810 may switch from new trajectory 836 to original trajectory 830. After receiving and possibly validating new trajectory 836, autonomous vehicle 810 may drive according to new trajectory 836 to endpoint 838 and then according to original trajectory 830 to destination 832. In some embodiments, endpoint 838 might not be on original trajectory 830. Instead, endpoint 838 may allow autonomous vehicle 810 to proceed to a location that may partially relieve the stuck condition. From this location, autonomous vehicle 810 may calculate and/or drive according to one or more additional trajectories that may result in autonomous vehicle 810 eventually rejoining original trajectory 830.

FIG. 9 shows an example scenario 900 where autonomous vehicle 810 is attempting to drive on road 902 following original trajectory 930 to destination 932. Road 902 is similar to road 802 of FIG. 9. However, road 902 has shoulders 904, 906 while road 802 does not have shoulders. Associated with road 902 is sign 910 indicating that “SHOULDER RIDING” is “ALLOWED”. In example scenario 900, vehicles 812, 814, 816, and/or 818 may be stopped or moving slowly (e.g., below a threshold speed).

Scenario 900 shows that original trajectory 830 is blocked by vehicle 814. Although autonomous vehicle 810 may be permitted to drive on a left lane of road 902, vehicle 812 blocks that trajectory. Thus, autonomous vehicle 810 may be in a stuck condition.

In scenario 900, upon recognizing that it is in the stuck condition, autonomous vehicle 810 may send an assistance signal to an assistance center (not shown in FIG. 9) to relieve the stuck condition. As part of the assistance signal or in another communication, autonomous vehicle 810 may provide proposed trajectory 936 to the assistance center for consideration. For example, scenario 900 may have occurred after scenario 800 and autonomous vehicle 810 may have stored trajectory 836. Thus, autonomous vehicle 810 may have considered trajectory 836 for use in scenario 900 (possibly with slight modifications as bottles 820, 822, and 824 are slightly farther from vehicle 810), and proposed trajectory 936 based on the slightly-modified trajectory 836. As shown in FIG. 9, proposed trajectory 936 may rejoin original trajectory 930 at proposed endpoint (PEP) 938.

Upon receiving the assistance signal, the assistance center may request and subsequently receive additional information about autonomous vehicle 810 and its environment. In particular, an expert at the assistance center may be provided with image(s) and/or other information about sign 910, and so learn that shoulder riding is allowed. Then, the expert may examine information about shoulder 906 and determine that new trajectory 946 taking shoulder 906 may be used by autonomous vehicle 810 to bypass vehicle 814. As shown in FIG. 9, new trajectory 946 may rejoin original trajectory 930 at new endpoint (NEP) 948. New trajectory 946 has an advantage of generally keeping autonomous vehicle 810 further from obstacles. Therefore, the assistance center may reject proposed trajectory 936 in favor of new trajectory 940.

In providing new trajectory 946 to autonomous vehicle 810, the assistance center may provide a temporary override of any rules inhibiting autonomous vehicle 810 from shoulder riding at least while traveling on new trajectory 946. In scenario 900, autonomous vehicle 810 may receive new trajectory 946 with a temporary override allowing shoulder riding, verify new trajectory 946, and request the assistance center confirm new trajectory 946. Then, the assistance

center may confirm new trajectory **946**. Upon receiving confirmation of new trajectory **946**, autonomous vehicle **810** may take new trajectory **946** to new endpoint **948**. At new endpoint **948**, autonomous vehicle **810** may rejoin original trajectory **930**, and drive to destination **932**, in accordance to original trajectory **930**.

FIG. **10** is a flow chart of an example method **1000** that could be used in conjunction with either method **800**, method **900**, or other methods disclosed herein or defined elsewhere. In example method **1000**, autonomous vehicle **1010** may request assistance from assistance center **520** to relieve a stuck condition. For instance, autonomous vehicle **1010** may determine that it is in a stuck condition and send assistance signal **1022** to assistance center **520**. After receiving assistance signal **1022**, assistance center **520** may send request **1024** to connect to autonomous vehicle **1010**.

At block **1026**, after connecting to autonomous vehicle **1010**, an expert at assistance center **520** may assess a state of autonomous vehicle **1010**. The expert may be a human expert, an expert system and/or other computer components, and/or a combination of human expert(s) and computer component(s).

At block **1030**, the expert at assistance center **520** may determine whether or not assistance center **520** is to intervene with the navigation of autonomous vehicle **1010**. If the expert at assistance center **520** determines to intervene, then assistance center **520** may send request **1032** to enter augmented mode. During augmented mode, autonomous vehicle **1010** may provide additional data to assistance center **520**. This additional data may be a combination of location and sensor data from the autonomous vehicle.

At block **1040**, autonomous vehicle **1010** may determine whether it should enter augmented mode. For example, autonomous vehicle **1010** may determine whether enough network capacity is available to transmit the necessary data, and/or perform other checks to determine whether or not augmented mode may be entered.

If autonomous vehicle **1010** determines that it should enter augmented mode, then autonomous vehicle **1010** may (periodically or from time to time) send additional data **1044** to assistance center **520**. Autonomous vehicle **1010** may apply one or more heuristics to determine additional data **1044** prior to sending. Additional data **1044** may include low-level perceptual data about obstacles, high-level perceptual data about objects, video data, still images, location data and/or audio data. Further, as previously discussed, this additional data may be a subset of all environmental data available to autonomous vehicle **1010**, selecting according to, for instance, relative importance.

In some embodiments, at block **1050**, autonomous vehicle **1010** may propose a trajectory to relieve the stuck condition. The proposed trajectory may include a path from a current position of autonomous vehicle **1010** to an endpoint where the proposed trajectory joins an original trajectory that autonomous vehicle **1010** was utilizing prior to entering the stuck condition. Alternatively, endpoints that are not on the original trajectory may be used.

Autonomous vehicle **1010** may send proposed trajectory **1052** to assistance center **520**. At block **1054**, the expert at assistance center **520** may determine whether or not proposed trajectory **1052** relieves the stuck condition while adhering to the navigational constraints of autonomous vehicle **1010**. These navigational constraints may include, for instance, the autonomous vehicle avoiding collisions, obeying traffic laws, and/or not causing inertial discomfort to its passengers. If the expert at assistance center **520**

determines that this is the case, assistance center **520** may send confirmation **1056** of proposed trajectory **1052** to autonomous vehicle **1010**.

If the expert at assistance center **520** determines that this is not the case, the expert at assistance center **520** may devise a trajectory to relieve the stuck condition. For example, the expert may modify an existing plan, modify a solution provided by autonomous vehicle **1010**, or generate a new plan in order to devise the trajectory. The devised trajectory may include a path from the current position of autonomous vehicle to an endpoint where the devised trajectory joins the original trajectory of autonomous vehicle **1010**, or to some other endpoint. Assistance center **520** may send devised trajectory **1062** to autonomous vehicle **1010**.

At block **1064**, autonomous vehicle **1010** may receive a representation of trajectory T, which may be either proposed trajectory **1052** or devised trajectory **1062**. At block **1066**, autonomous vehicle **1010** may determine whether or not it may follow trajectory T to relieve the stuck condition. For example, autonomous vehicle **1010** may determine that autonomous vehicle **1010** may actually execute the trajectory T without violating any rules of operation for autonomous vehicle **1010**; e.g., traffic laws. As another example, autonomous vehicle **1010** may recheck locations of objects to verify that trajectory T will likely not lead to a collision.

If autonomous vehicle **1010** determines that it may follow trajectory T, autonomous vehicle **1010** may send final confirmation request **1070** for trajectory T. In some scenarios, autonomous vehicle **1010** may not be able to confirm trajectory T, for instance, due to a lack of sensor data regarding the safety of trajectory T. In these scenarios, autonomous vehicle **1010** may send a message to assistance center **520** rejecting trajectory T, perhaps including one or more reasons for rejecting trajectory T.

At block **1072**, the expert at assistance center **520** may verify that trajectory T is valid; e.g., that trajectory T may relieve the stuck condition without violating the navigational constraints of autonomous vehicle **1010**. If the expert at assistance center **520** verifies trajectory T, assistance center **520** may send confirmation **1080** of trajectory T to autonomous vehicle **1010**. At block **1090**, autonomous vehicle **1010** may drive according to trajectory T, to an endpoint of trajectory T, to relieve the stuck condition.

As autonomous vehicle **1010** drives according to trajectory T, autonomous vehicle **1010** may continue to receive new environmental data, such as new laser strike data. In cases where this new environmental data indicates that autonomous vehicle **1010** cannot follow trajectory T, autonomous vehicle **1010** may respond accordingly. For instance, based on the nature of the new environmental data, autonomous vehicle **1010** may avoid new obstacles, or once again determine that it is stuck. In this way, autonomous vehicle **1010** may avoid blindly following a trajectory when doing so puts autonomous vehicle **1010** at risk of colliding with another object.

Nonetheless, low-level data, such as clusters of laser strikes on surfaces in the vicinity of the autonomous vehicle, may be useful to the assistance center. FIG. **11** schematically illustrates a LIDAR unit **1102**, perhaps mounted to, attached to, or part of an autonomous vehicle, scanning across an obstacle-filled environment. The example environment depicted in FIG. **11** includes a car **1110** and a tree **1112**.

In operation, LIDAR unit **1102** may rotate according to motion reference arrow **1108** with angular velocity ω . While rotating, LIDAR unit **1102** regularly (e.g., periodically or from time to time) emits laser beams, such as a laser beam **1106**. Reflections from the emitted laser beams caused by

objects in the environment, such as the car **1110** and the tree **1112**, may be received by suitable sensors associated with LIDAR unit **1102**. Time-stamping the receipt of the reflected signals allows for associating each reflected signal (if any is received at all) with the most recently emitted laser pulse, and measuring the time delay between emission of the laser pulse and reception of the reflected light.

The time delay provides an estimate of the distance to the reflective feature by scaling according to the speed of light in the intervening atmosphere. Combining the distance information for each reflected signal with the orientation of LIDAR unit **1102** for the respective pulse emission allows for determining a position of the reflective feature in three-dimensions.

In some embodiments, LIDAR unit **1102** may be configured to capture one or more laser point clouds of the environmental scene at predetermined time intervals, such as 100 milliseconds (for a refresh rate of 10 frames per second), 33 milliseconds (for a refresh rate of 30 frames per second), 1 millisecond, 1 second, etc.

In some embodiments, a single laser in LIDAR unit **1102** may have a scanning range of approximately 150 meters distance, a thirty degree vertical (“altitude”) field of view, and approximately a thirty degree horizontal (“azimuth”) field of view. Additional lasers included in LIDAR unit **1102** may have complementary ranges and fields of view as well so as to provide sufficient coverage of an environmental scene to inform navigational determinations.

FIG. **12** schematically illustrates an example point cloud corresponding to the obstacle-filled environmental scene of FIG. **11**. Spatial-point data (represented by stars) are shown from a ground-plane (or aerial) perspective. Even though the individual points are not equally distributed in space throughout the sampled environment, adjacent sampled points are roughly equally spaced angularly with respect to LIDAR unit **1102**. In some embodiments, point clouds may have as many as 50,000 laser-indicated points, 80,000 laser-indicated points, 100,000 laser-indicated points, etc. More or fewer laser-indicated points may be used.

Car spatial data **1214** may correspond to measured points on the surface of car **1110** with a line of sight to LIDAR unit **1102**. Similarly, tree spatial data **1216** may correspond to measured points on the surface of tree **1112** visible from LIDAR unit **1102**. The absence of points between car spatial data **1214** and tree spatial data **1216** indicates an absence of reflective features along the sampled line of sight paths in the plane illustrated.

Each point in the example point cloud illustrated in FIG. **12** may be referenced by an azimuth angle φ (e.g., the orientation of LIDAR unit **1102** while emitting the pulse corresponding to the point), which is determined by the orientation of a rotating angled mirror (not shown) of LIDAR unit **1102** and a line-of-sight (LOS) distance (e.g., the distance indicated by the time delay between pulse emission and reflected light reception). For emitted pulses that do not receive a reflected signal, the LOS distance may optionally be set to the maximum distance sensitivity of LIDAR unit **1102**. The maximum distance sensitivity may be determined according to the maximum time delay the associated optical sensors wait for a return reflected signal following each pulse emission, which may itself be set according to the anticipated signal strength of a reflected signal at a particular distance given ambient lighting conditions, intensity of the emitted pulse, predicted reflectivity of environmental features, etc. In some examples, the maximum distance may be approximately 60 meters, 80 meters, 100 meters, or 150 meters, but other examples of maximum

distance are possible for particular configurations of LIDAR unit **1102** and associated optical sensors.

In some embodiments, car spatial data **1214** may be low-level “strike input” data. This low-level data may be considered alone and/or in combination with additional sensor-indicated information, memory-based pattern-matching point clouds, and/or baseline maps of the environment to generate high-level, polygonal or polyhedral representations of objects in the environment. The high-level, polygonal or polyhedral representations may be generated by categorizing or identifying car spatial data **1214** as corresponding to car **1110** and generating a polygonal or polyhedral representation of car **1110**. Similarly, tree spatial data **1216** may be identified as corresponding to tree **1112** in accordance with a suitable object-detection technique and so lead to generation of a polygonal or polyhedral representation of tree **1112**.

This processing may make use of an object detector. An object detector may be any configuration of software and/or hardware configured to perceive features in the environmental scene by categorizing object(s), identifying object(s), and/or generating polygonal or polyhedral representation(s) of categorized/identified objects based on the low-level laser point clouds captured by LIDAR unit **1102** and/or based on one or more of the sensors in the sensor system **1604**. As a laser point cloud is captured via LIDAR unit **1102**, data indicative of the captured point cloud is communicated to the object detector, which analyzes the data to determine whether there is an object present in the laser point cloud. Objects indicated by the point cloud may be, for example, a vehicle (e.g., car **1110**) an obstacle (e.g., tree **1112**), a pedestrian, a road sign, a traffic light, a traffic cone, etc.

To determine whether an object is present in a laser point cloud image, the object-detector software and/or module may associate arrangements of laser-indicated points with patterns matching objects, environmental features, and/or categories of objects or features. The object detector may be pre-loaded (or dynamically instructed) to associate arrangements according to one or more parameters corresponding to physical objects/features in the environment surrounding vehicle **1110**. For example, the object detector may be pre-loaded with information indicating a typical height of a pedestrian, a length of a typical automobile, confidence thresholds for classifying suspected objects, etc.

If an object (or objects) is present in the point cloud, the object detector may generate a polygonal or polyhedral representation corresponding to the object. For example, when the object detector identifies an object in a point cloud, the object detector may define a bounding box encompassing the object. The bounding box may correspond to a predicted exterior surface of the point cloud indicated object. Of course, the bounding “box” may generally take the form of a multi-sided polygon or polyhedron defining the predicted outer boundaries of the object.

For each captured point cloud, positions of perceived objects and their corresponding boundary definitions are associated with a frame number or frame time. Thus, similarly shaped objects appearing in the same or roughly similar locations in successive scans of the scene may be associated with one another to track objects in time. Perceived objects appearing in multiple point cloud frames (e.g., complete scans of the scanning zone), may be considered to be the same object, and may be either stationary or in motion relative to vehicle **1110**. Each perceived object may be associated, for each frame on which the perceived object appears, with a distinct bounding shape defining the dimensional extent of the perceived object.

Further, as noted above, each spatial point may be associated with a respective laser from a set of lasers and a respective timestamp. That is, in an embodiment where LIDAR unit **1102** includes multiple lasers, each respective spatial point may be associated with the particular laser that detected the respective spatial point. Additionally, each respective spatial point may be associated with a respective timestamp (e.g., a time at which the particular laser was emitted or received). In this way, the received spatial points may be organized, identified, or otherwise ordered on a spatial (laser identification) and/or temporal (timestamp) basis. Such an ordering may assist or improve an analysis of the spatial point data by allowing for organizing the spatial point data into a meaningful order. Some or all of the laser strike data, point cloud data, and/or object-related bounding box data may be stored by the autonomous vehicle.

FIG. **13** schematically illustrates spatial point data indicative of a surface of a target vehicle that is stationary relative to a LIDAR unit, according to an example embodiment. The LIDAR unit may be mounted on an autonomous vehicle or otherwise integrated or associated with an autonomous vehicle. In this example, a target surface **1318** is identified from a set of spatial points indicative of locations of reflective surfaces received from LIDAR unit **1102** by an object-detection technique mentioned herein and/or any other known or later developed. In some embodiments, the set of spatial points is received from a single sweep of LIDAR unit **1102**. Target surface **1318** may be a front or rear surface of a target vehicle, such as vehicle **1110**.

In this example, a first point **1320** and a second point **1326** are also identified by an object-detection technique mentioned herein and/or any other known or later developed. The first point **1320** is indicative of a first location **1322** on target surface **1318** obtained from LIDAR unit **1102** at a first time **1324**, and the second point **1326** is indicative of a second location **1328** on target surface **1318** obtained from LIDAR unit **1102** at a second time **1330**. Other points illustrated in FIG. **13** may be indicative of other locations on target surface **1318** obtained from LIDAR unit **1102** at other times. With this arrangement, a speed of target surface **1318** relative to LIDAR unit **1102** may be estimated based on the first location **1322**, the first time **1324**, the second location **1328**, and the second time **1330**.

In this example, the estimate of a relative speed of target surface **1318** may be determined based on an offset between first location **1322** and second location **1328** divided by a time difference between the second time **1330** and the first time **1324**.

As illustrated in FIG. **13**, a coordinate frame **1332** includes a longitudinal axis **1334**. In this example, target surface **1318** is perpendicular to the longitudinal axis **1334**. A projected first point **1336** may be determined by projecting the first point **1320** onto the longitudinal axis **1334**, and a second point **1338** may be determined by projecting the second point **1326** onto the longitudinal axis **1334**. With this arrangement, the offset between the first location **1322** and the second location **1328** is determined as a distance between the projected first point **1336** and the projected second point **1338**.

In this example, the offset is zero because the projected first point **1336** and the projected second point **1338** are each at the same location on the longitudinal axis **1334**. Accordingly, the estimate of the speed of target surface **1318** in this example is zero.

In some embodiments, the coordinate frame **1332** may include a fixed coordinate frame in an environment of LIDAR unit **1102** based on data from an inertial measure-

ment unit (IMU) associated with a vehicle. However, in some embodiments, the defining of a coordinate frame may also be based at least in part on data from other sensors associated with the vehicle. For instance, the defining of a coordinate frame may also be based at least in part on data from a GPS associated with the vehicle. Doing so may improve estimates of the speed and trajectory of target surface **1318**. Other examples are also possible.

In some embodiments, the longitudinal axis **1334** may be defined based on a direction of motion of LIDAR unit **1102** and/or a direction of motion of target surface **1318**. In some examples, the direction of motion of LIDAR unit **1102** is known. However, in other examples, the direction of motion of LIDAR unit **1102** may be identified based on any technique mentioned herein and/or any other known or later developed. For instance, the direction of motion of LIDAR unit **1102** may be identified based on a direction of a path that LIDAR unit **1102** is traveling, such as a roadway or a traffic lane. In some examples, the direction of motion of target surface **1318** is known. However, in other examples, the direction of motion of target surface **1318** may be identified based on any technique mentioned herein and/or any other known or later developed.

FIG. **14** schematically illustrates spatial point data indicative of a surface of a target vehicle that is moving relative to the LIDAR unit, according to an example embodiment. In this example, a first point **1440** and a second point **1446** on target surface **1318** are also identified by an object-detection technique discussed herein and/or any others known or later developed. First point **1440** is indicative of a first location **1442** on target surface **1318** obtained from LIDAR unit **1102** at a first time **1444**, and second point **1446** is indicative of a second location **1448** on target surface **1318** obtained from LIDAR unit **1102** at a second time **1450**. Other points illustrated in FIG. **14** may be indicative of other locations on target surface **1318** obtained from LIDAR unit **1102** at other times.

In this example, target surface **1318** has a known direction of motion **1458**. Further, an estimate of a speed of target surface **1318** may be determined based on an offset between first location **1442** and second location **1448** divided by a time difference between second time **1450** and first time **1444**.

A projected first point **1452** may be determined by projecting first point **1440** onto longitudinal axis **1334**, and a projected second point **1454** may be determined by projecting second point **1446** onto longitudinal axis **1334**. With this arrangement, the offset between first location **1442** and second location **1448** may be determined as a distance between projected first point **1452** and projected second point **1454**. The offset is greater than zero because projected first point **1452** and projected second point **1454** are separated by a non-zero distance on longitudinal axis **1334**. Accordingly, the estimate of the speed of target surface **1318** is greater than zero. As illustrated in FIG. **14**, the distance may represent a longitudinal distance traveled **1456** by target surface **1318**.

FIGS. **15A**, **15B**, and **15C** show scenario **1500** using trajectory user interface (UI) **1510** to relieve a stuck condition of an autonomous vehicle. In some embodiments, trajectory UI **1510** may be provided using a graphical user interface (GUI) of a computing device. For example, trajectory UI **1510** may utilize one or more windows, buttons, dialogs, and other components of the GUI. In scenario **1500**, trajectory UI **1510** may be utilized at an assistance center, such as assistance center **520**, and may be configured to communicate with one or more autonomous vehicles and

with one or more experts. The expert(s) may be human experts and/or computing components, such as but not limited to expert systems. Alternatively or additionally, trajectory UI 1510 may be utilized in an autonomous vehicle, perhaps by a passenger of the autonomous vehicle.

FIG. 15A shows a display of trajectory UI 1510 including an autonomous vehicle/data selection section 1511, autonomous vehicle display 1520, and a display control section 1570. In some embodiments, more, less, or different sections and/or displays may be provided using trajectory UI 1510.

Autonomous vehicle/data selection section 1511 includes autonomous vehicle selection button 1512, video data button 1514, low-level data button 1516, and high-level data button 1518. In some embodiments, more, less, or different buttons may be provided in the autonomous vehicle/data selection section of trajectory UI 1510.

In FIGS. 15A-15C, buttons that are selected are shown with a gray background, while buttons that are not selected are shown with a white background. For example, in scenario 1500, high-level data button 1518 is selected, while autonomous vehicle selection button 1512, video data button 1514 and low-level data button 1516 are not selected.

Upon selection, autonomous vehicle selection button 1512 may instruct trajectory UI 1510 to display a dialog or similar graphical component (not shown in the figures) listing autonomous vehicles seeking assistance. An expert may use the dialog to select an autonomous vehicle to assist, and upon selection, begin communication with the selected autonomous vehicle. Once an autonomous vehicle is selected for assistance, trajectory UI 1510 may display an identifier and/or other information for the selected autonomous vehicle. FIG. 15A shows an identifier "AVx123" for an autonomous vehicle selected for assistance during scenario 1500. Then, when the expert has finished assisting the selected autonomous vehicle, the expert may use autonomous vehicle selection button 1512 to select another autonomous vehicle to be assisted, assuming that another autonomous vehicle has requested assistance.

Video data button 1514, when selected, may be used to generate a request to a selected autonomous vehicle to provide video data. The video data may include sequences of images configured for display in succession at a constant rate and/or still images. Once video data is available, trajectory UI 1510 may display the video data using autonomous vehicle display 1520 and/or using another display or window. In some embodiments, if more than one of buttons 1514, 1516, and 1518 are selected, separate displays or windows may be provided by trajectory UI 1510 for each type of data; e.g., video data associated with button 1514, low-level data associated with button 1516, and high-level data associated with button 1514. Low-level data and high-level data are discussed below in more detail at least in the context of FIG. 16. Alternatively or additionally, some or all of video data, low-level data, and high-level data may be combined into one display.

Low-level data button 1516, when selected, may generate a request to a selected autonomous vehicle to provide low-level data. When the low-level data is available, the low-level data may be displayed using autonomous vehicle display 1520 and/or using another display or window. High-level data button 1518, when selected, may generate a request to a selected autonomous vehicle to provide high-level data. When the high-level data is available, the high-level data may be displayed using autonomous vehicle display 1520 and/or using another display or window.

In some embodiments, the autonomous vehicle selects data for transmission to the assistance center. In these

embodiments, selection of one of buttons 1514, 1516, or 1518 may not lead to a request for data; rather, trajectory UI 1510 may indicate that such data is available by changing display of buttons 1514, 1516, and/or 1518 to indicate data availability. Then, if the expert selects a button associated with available data, the data may be displayed using autonomous vehicle window 1520 or another window. And, upon selection of a button not associated with available data, an error message/dialog may be generated indicating the unavailability of the selected data. In particular embodiments, even if the autonomous vehicle selects data for transmission, the autonomous vehicle may honor a request for data, and in these embodiments, upon selection of a button not associated with available data, a request for the data may be sent to the autonomous vehicle.

In scenario 1500, high-level data is provided by the autonomous vehicle and is selected, as indicated by the gray background of button 1518 in FIG. 15A. As such, autonomous vehicle display 1520 shows high-level data, represented as graphical objects, representing autonomous vehicle AVx123 1530, road 1532, gates 1534a, 1534b, bovines 1542, 1544, and calves 1546 and 1548. In scenario 1500, bovines 1542, 1544 and calves 1546, 1548 are travelling to the left, crossing road 1532 to enter a field (not shown) accessible via an opening between gate 1534a and gate 1534b. Autonomous vehicle AVx123 1530 has an original trajectory 1540 that would impact bovine 1542 at or shortly after time "17:23:04 PDT".

As such, autonomous vehicle AVx123 1530 is in a stuck condition. In scenario 1500, prior to requesting assistance, autonomous vehicle AVx123 1530 may have waited for a timer to expire upon determining this stuck condition, such as discussed in detail in the context of FIG. 7, based on a cause that bovines 1542, 1544 and calves 1546, 1548 are obstructing trajectory 1540. At 17:23:04 PDT, as shown in FIG. 15A, only bovine 1542 remains obstructing trajectory 1540.

Display controls section 1570 of trajectory UI 1510 is shown in FIG. 15A with six buttons: show autonomous vehicle trajectory button 1580, show attractors button 1582, show repellers button 1584, draw new trajectory button 1586, send new trajectory button 1588, and approve trajectory button 1590. FIG. 15A shows that buttons 1580 and 1584 are selected and buttons 1582, 1586, 1588, and 1590 are not selected. In some embodiments, more, less, or different buttons are provided in the display controls section of trajectory UI 1510.

Autonomous vehicle trajectory button 1580, when selected, instructs autonomous vehicle display 1520 to display a trajectory for the selected autonomous vehicle. As autonomous vehicle trajectory button 1580 is selected, trajectory 1540 for selected autonomous vehicle AVx123 is displayed on display 1520. FIG. 15A shows trajectory 1540 as an arrow from a display of high-level object 1530 representing AVx123 going toward the top of the figure. In some embodiments, if autonomous vehicle trajectory button 1580 were selected again, autonomous vehicle trajectory button 1580 may act as a toggle and display 1520 would no longer display trajectory 1540.

Show attractors button 1582 may, when selected, instruct autonomous vehicle display 1520 to show "attractors." Similarly, show repellers button 1584 may, when selected, instruct autonomous vehicle display 1520 to show "repellers." In some embodiments, providing trajectories to an autonomous vehicle may be modeled as an energy minimization problem defined by a series of attractors and repellers.

These attractors and repellers may be placed by an expert, or may be automatically determined by autonomous vehicle AVx123.

One or more attractors, or positive potentials, may exist or may be inserted along a center of a lane of road 1532. Attractors may be placed in other positions that are desirable for autonomous vehicle travel. Attractors are not explicitly shown in FIGS. 15A, 15B, and 15C.

Repellers, or negative potentials, may exist or may be inserted at undesirable positions, such as at the edges of lanes and surrounding obstacles that may partially or completely block a trajectory of an autonomous vehicle. In FIGS. 15A-15C, repellers are shown in autonomous vehicle display 1520 as dashed lines. For instance, repellers 1542r, 1544r, 1546r, 1548r exist around bovines/calves 1542, 1544, 1546, 1548, respectively. Repellers are also shown near the edges of road 1532.

In some embodiments, an expert may specify an endpoint and a series of attractors and repellers with controls for varying the strength and radius of effect of these potentials. These data may be provided to autonomous vehicle AVx123 to define a new trajectory that tries to take attractive paths and avoid repelled paths.

Draw new trajectory button 1586, when selected, allows the expert to enter an augmented trajectory for autonomous vehicle AVx123. Send new trajectory button 1588, when selected, allows the expert to send the augmented trajectory for autonomous vehicle AVx123. Approve trajectory button 1590, when selected, allows the expert to send a message to the autonomous vehicle that approves a trajectory sent by autonomous vehicle AVx123. Once a trajectory is approved, autonomous vehicle AVx123 may drive along the approved trajectory to relieve a stuck condition, or for another purpose.

In some embodiments, an augmented or new trajectory for an autonomous vehicle may be specified based on two points: a point of departure from an existing trajectory and an endpoint. The endpoint may be a point of return to the existing trajectory or a point that is not part of the existing trajectory. For instance, the endpoint might specify a location to which the autonomous vehicle can drive that at least partially relieves the stuck condition. In particular embodiments, the point of departure may be inferred as a current position of the autonomous vehicle, and so only the point of return may be explicitly specified.

The trajectory may also include collection of waypoints to navigate between (i) the point of departure or a current position, and (ii) the endpoint of the trajectory. The collection of waypoints may be specified using a spline, which is a piecewise-smooth function connected by the waypoints. Upon reaching the endpoint, the autonomous vehicle may continue with the original trajectory. In some embodiments, some or all of the collection of waypoints may be specified other than by a spline; e.g., using piecewise linear functions, other piecewise-smooth functions, polynomials, lists of waypoints, etc.

Turning to FIG. 15B, scenario 1500 continues at time "17:23:49 PDT" where autonomous vehicle AVx123 has provided a proposed trajectory 1550 and proposed maximum speed 1552 to relieve the stuck condition. FIG. 15B shows that autonomous vehicle display 1520 portrays proposed trajectory 1550 as a relatively thin arrow from a starting point or point of departure, shown as the letter "s" in a circle, through a waypoint shown as the letter "A" in a circle, to an endpoint or point of return, shown as the letter "e" in a circle. In some embodiments, an autonomous vehicle may propose a maximum speed to travel on a

proposed trajectory. FIG. 15B shows the proposed maximum speed 1552 for trajectory 1550 of 1.2 meters/second. In some embodiments, an autonomous vehicle may propose a trajectory to relieve a stuck condition (or for some other purpose) without proposing a related speed, such as a maximum, minimum or average speed. Alternatively or additionally, the autonomous vehicle may also or instead propose minimum and/or average speeds.

Upon reviewing proposed trajectory 1550, the expert may determine that proposed trajectory 1550 may come too close to bovine 1542. Then, the expert may specify a different trajectory than proposed trajectory 1550. In scenario 1500, as shown in FIG. 15B, the expert may press draw new trajectory button 1586 to specify a trajectory.

FIG. 15C shows that scenario 1500 continues at time "17:24:04 PDT" with draw new trajectory button 1586 selected. The expert has also specified new trajectory 1560 connecting the point of departure "s" and the point of return "e" of proposed trajectory 1550 using spline 1564 with three waypoints. The new trajectory 1560 takes a wider path around bovine 1542, and should be safer for autonomous vehicle AVx123 than proposed trajectory 1550. In scenario 1500, a maximum speed for traveling along trajectory 1560 may be specified by dialog 1562, which shows a current maximum speed selection of 1.2 meters per second, a "+" button for incrementing the maximum speed, and a "-" for decrementing the maximum speed.

FIG. 15C shows spline 1564 using a dotted and dashed line connecting points "s" and "e" and the three waypoints using circled numbers "1", "2", and "3". In some embodiments, different techniques may be used to display trajectories proposed by autonomous vehicles and/or by experts; e.g., different colors, fonts, characters, etc. may be used to distinguish trajectories.

Feedback may be used to aid an expert in drawing a trajectory. For example, if show repellers button 1584 is selected, as shown in FIG. 15C, then trajectory interface 1510 may generate a vibration, sound, or graphical indication when a drawn trajectory touches a repeller or an object. As another example, if show attractors button 1582 is selected, trajectories may be pre-selected by trajectory interface 1510 that partially or completely follow one or more attractors that are unobstructed by objects. Other examples are possible as well.

While not shown in the figures, scenario 1500 may continue with the expert pressing send new trajectory button 1588. Pressing send new trajectory button 1588 may instruct trajectory interface 1510 to send trajectory 1560 to autonomous vehicle AVx123. Autonomous vehicle AVx123 may then examine trajectory 1560 and request approval of the trajectory. Upon receiving the request, trajectory interface 1510 may provide an indication of the request for approval. Then, the expert may press the approve trajectory 1590 button to send an approval to autonomous vehicle AVx123. Autonomous vehicle AVx123 may then drive along trajectory 1560 from point of departure "s" via waypoints "1", "2", and "3" to reach point of return "e". Upon reaching point "e", the stuck condition for autonomous vehicle AVx123 is relieved and scenario 1500 may end.

FIG. 16 shows a block diagram of components of an example autonomous vehicle 1600. In some embodiments, autonomous vehicle 1600 may include at least some of the herein-described functionality of autonomous vehicles 510, 512, 514, 610, 810, 1010, and 1800. Additionally, autonomous vehicle 1600 may be configured to operate in an operational mode, such as a non-autonomous mode, a partially-autonomous mode, or an autonomous-operation mode.

The non-autonomous mode may use human input to select and execute driving behaviors during operation of the autonomous vehicle. In some instances, while in non-autonomous mode, the autonomous vehicle may operate like a traditional, non-autonomous vehicle.

The partially-autonomous mode may involve both a vehicle control system, such as control system **1606** of autonomous vehicle **1600**, and human inputs to select driving behaviors during operation of autonomous vehicle **1600**. For example, the autonomous vehicle control system may generate indications of driving behaviors for review by a human driver. For each indication, the human driver may review the indication and operate the autonomous vehicle by carrying out, modifying, or ignoring the indication. In some cases, the partially-autonomous mode may involve the autonomous vehicle performing all actions to navigate and drive the autonomous vehicle, where a human driver may monitor the autonomous vehicle's performance and intervene if and when necessary; e.g., to avert an accident. In other cases, as described herein, autonomous vehicle **1600** may request assistance from an assistance center; e.g., assistance center **520**. Additional techniques for operating an autonomous vehicle in a partially-autonomous mode, such as auto-piloting and automatic parking, are possible as well.

In the autonomous-operation mode, the autonomous vehicle control system may select and execute driving behaviors along at least part of a route without human input. The autonomous-operation mode may be subdivided into an autonomous mode utilizing a trained driver, an autonomous mode with a non-trained human driver, and an autonomous mode without a human driver. In autonomous-mode operation with a human driver, the vehicle control **1606** system may be configured to receive feedback from the human passenger about driving quality of the autonomous vehicle, and, in some circumstances, for the human driver to operate the autonomous vehicle.

Autonomous vehicle **1600** may include various systems such as a propulsion system **1602**, a sensor system **1604**, a control system **1606**, one or more peripherals **1608**, as well as a power supply **1670**, a computing device **1680**, and a user interface **1690**. Autonomous vehicle **1600** may include more or fewer systems and each system may include multiple aspects. Further, each of the systems and aspects of autonomous vehicle **1600** may be interconnected. Thus, one or more of the described functions of autonomous vehicle **1600** may be divided into additional functional or physical components, or combined into fewer functional or physical components. In some further examples, additional functional and/or physical components may be added to the examples illustrated by FIG. **16**.

Propulsion system **1602** may include components operable to provide powered motion for autonomous vehicle **1600**. In an example embodiment, propulsion system **1602** may include an engine/motor **1610**, an energy source **1612**, a transmission **1614**, and wheels/tires **1616**. Engine/motor **1610** may be any combination of an internal combustion engine, an electric motor, steam engine, Stirling engine, or other types of engines and/or motors. In some embodiments, engine/motor **1610** may be configured to convert energy source **1612** into mechanical energy. Propulsion system **1602** may include multiple types of engines and/or motors. For instance, a gas-electric hybrid car may include a gasoline engine and an electric motor. Other examples are possible.

Energy source **1612** may represent a source of energy that may, in full or in part, power engine/motor **1610**. That is, engine/motor **1610** may be configured to convert energy

source **1612** into mechanical energy. Examples of energy sources **1612** include gasoline, diesel, other petroleum-based fuels, propane, other compressed gas-based fuels, ethanol, solar panels, batteries, and other sources of electrical power. Energy source **1612** may additionally or alternatively include any combination of fuel tanks, batteries, capacitors, and/or flywheels. Energy source **1612** may also provide energy for other systems of autonomous vehicle **1600**.

Transmission **1614** may include aspects that are operable to transmit mechanical power from engine/motor **1610** to wheels/tires **1616**. To this end, transmission **1614** may include a gearbox, clutch, differential, and drive shafts. Transmission **1614** may include other aspects. The drive shafts may include one or more axles that may be coupled to the one or more wheels/tires **1616**.

Wheels/tires **1616** of autonomous vehicle **1600** may be configured in various formats, including a unicycle, bicycle/motorcycle, tricycle, or car/truck four-wheel format. Other wheel/tire geometries are possible, such as those including six or more wheels. Any combination of wheels/tires **1616** of autonomous vehicle **1600** may be operable to rotate differentially with respect to other wheels/tires **1616**. Wheels/tires **1616** may represent at least one wheel that is fixedly attached to transmission **1614** and at least one tire coupled to a rim of the wheel that may make contact with the driving surface. Wheels/tires **1616** may include any combination of metal and rubber, or another combination of materials.

Sensor system **1604** may include a number of sensors configured to sense information about an environment of autonomous vehicle **1600**. For example, sensor system **1604** may include a GPS **1620**, an inertial measurement unit (IMU) **1622**, a radar unit **1624**, a LIDAR unit **1626**, and a camera **1628**. Other sensors are possible as well. One or more of the sensors included in sensor system **1604** may be configured to be actuated separately and/or collectively in order to modify a position and/or an orientation of the one or more sensors.

GPS **1620** may be any sensor configured to estimate a geographic location of autonomous vehicle **1600**. To this end, GPS **1620** may include a transceiver operable to provide information regarding the position of autonomous vehicle **1600** with respect to the Earth.

IMU **1622** may include any combination of sensors (e.g., accelerometers and gyroscopes) configured to sense position and orientation changes of autonomous vehicle **1600** based on inertial acceleration.

Radar unit **1624** may represent a system that utilizes radio signals to sense objects within the local environment of autonomous vehicle **1600**. In some embodiments, in addition to sensing the objects, radar unit **1624** may additionally be configured to sense the speed and/or heading of the objects.

LIDAR unit **1626** may be any sensor configured to sense objects in the environment in which autonomous vehicle **1600** is located using lasers. In an example embodiment, LIDAR unit **1626** may include one or more laser sources, a laser scanner, and one or more detectors, among other system components. LIDAR unit **1626** may be configured to operate in a coherent (e.g., using heterodyne detection) or an incoherent detection mode. In some embodiments, LIDAR unit **1626** may include at least some of the herein-described functionality of LIDAR unit **1102**.

Camera **1628** may include one or more devices configured to capture a plurality of images of the environment of autonomous vehicle **1600**. Camera **1628** may be a still

camera or a video camera, and may be capable of recording images in the infrared, visible, and/or ultraviolet frequency ranges. Camera **1628** may operate in conjunction with light source **1668**.

In some embodiments, obstacle data **1630** be stored as part of sensor system **1604**. Obstacle data **1630** may include image data **1632** and sensor data **1634**. Image data **1632** may include still and/or video images captured by autonomous vehicle **1600**; e.g., using camera **1628**. Sensor data may include location, radar, LIDAR, laser strike data, audio data, and/or other data captured by autonomous vehicle **1600**; e.g., using GPS **1620**, IMU **1622**, radar unit **1624**, LIDAR unit **1626**, microphone **1664**, and/or data generated by sensors within other components of autonomous vehicle **1600**, such as but not limited to engine, brake, and tire sensors.

In some embodiments, sensor data **1634** may include low-level data, or raw data from sensors associated with autonomous vehicle **1600**; e.g., radar data from radar unit **1624**, laser-strike data from LIDAR unit **1626**, and/or locations from GPS **1620** and IMU **1622**. Alternatively or additionally, sensor data **1634** may include high-level data, or processed data from sensors associated with autonomous vehicle **1600**. This high-level data may be derived, at least in part, from the low-level data.

In still other embodiments, sensor data **1634** may include both low-level and high-level data. In even other embodiments, part of all of obstacle/object data **1630** may be stored using computing device **1680**, either as a copy of data stored in sensor system **1604**, or rather than being stored in sensor system **1604**.

In some embodiments, data storage associated with computer device **1680** may store object-detector software, code, or other program instructions. Such object-detector software may include, or be part of, one or more of the subsystems of the control system **1606** described below, including sensor fusion algorithm **1650**, computer vision system **1652**, and/or obstacle avoidance system **1656**.

In some embodiments, the low level data and/or the high level data may be grouped or “bucketed” according to distance along a proposed trajectory of autonomous vehicle **1600**. For example, suppose buckets of size R meters, $R > 0$, are used. Then, data between X and $X+R$ meters ahead of autonomous vehicle **1600** may be put into bucket X . In some embodiments, X is divisible by R . If bucket X includes more than a threshold number T_{obj} of data objects, the proposed trajectory may be considered to intersect or come close to an obstacle somewhere between X meters and $X+R$ meters ahead.

Buckets may be used to test a proposed trajectory for safety. For example, if a bucket along the proposed trajectory has more than T_{obj} objects, then the proposed trajectory may be rejected by autonomous vehicle **1600**. Similarly, if autonomous vehicle **1600** is driving along a trajectory and determines that a bucket between $X1$ meters ahead has more than T_{obj} objects, then autonomous vehicle **1600** may come to controlled stop to avoid a collision approximately $X1$ meters away. Alternatively, if there is just one object blocking a trajectory, autonomous vehicle **1600** may reject the trajectory.

Control system **1606** may be configured to control operation of autonomous vehicle **1600** and its components. Accordingly, the control system **1606** may include various aspects include stuck condition detector **1640**, trajectory validation unit **1642**, driving/steering unit **1644**, throttle **1646**, brake unit **1648**, a sensor fusion algorithm **1650**, a computer vision system **1652**, a navigation/pathing system

1654, and an obstacle avoidance system **1656**. Control system **1606** may additionally or alternatively include components other than those shown and described.

Stuck condition detector **1640** may be configured to detect that the autonomous vehicle is in a stuck condition, so that autonomous vehicle **1600** may benefit from navigational assistance. In some embodiments, stuck condition detector **1640** may be a component of navigation-pathing system **1654**. In other embodiments, stuck condition detector **1640** may be a component of obstacle avoidance system **1656**.

Upon determining that autonomous vehicle **1600** is in a stuck condition, stuck condition detector **1640** may, in combination with communications component **1660**, send an assistance request to request assistance. The assistance request may be sent to assistance center **520**. In response, assistance center **520** may either (a) accept the assistance request and send a new trajectory for vehicle **1600** to navigate, or (b) reject the request. In some embodiments, autonomous vehicle **1600** may provide a proposed new trajectory to assistance center **520**, either for validation, editing, or replacement by a trajectory proposed by assistance center **520**. In some embodiments, the functions of assistance center **520** may be integrated with autonomous vehicle **1600**, perhaps as a way for a human driver or rider of autonomous vehicle **1600** to assist autonomous vehicle **1600** out of a stuck condition.

Trajectory validation component **1642** may determine whether or not autonomous vehicle **1600** may follow a new trajectory proposed by assistance center **520**. Trajectory validation component **1642** may validate the trajectory using data from sensors, such as indicated in sensor system **1604**, and navigational constraints on autonomous vehicle **1600**. In some embodiments, trajectory validation component **1642** may use buckets for validation as discussed elsewhere in this section. In other embodiments, assistance center **520** may provide temporary permission to autonomous vehicle **1600** to ignore some navigational constraints.

Driving/steering unit **1644** may include a steering unit representing any combination of mechanisms that may be operable to adjust the heading of autonomous vehicle **1600** and a driving unit. Driving/steering unit **1644** may be configured to drive in accordance with a trajectory, such as the original trajectory, and to accept modifications to the original trajectory and/or constraints based on a new trajectory, as well as any other information provided by assistance center **520**. The new trajectory may be based on a point of departure, a path that may be specified as a spline, and a point of return to an original trajectory, such as discussed above at least in the context of FIGS. **15A-15C**.

Throttle **1646** may be configured to control, for instance, the operating speed of the engine/motor **1610** and, in turn, control the speed of autonomous vehicle **1600**.

Brake unit **1648** may include any combination of mechanisms configured to decelerate autonomous vehicle **1600**. Brake unit **1648** may use friction to slow wheels/tires **1616**. In some cases, brake unit **1648** may convert the kinetic energy of wheels/tires **1616** to electric current. Brake unit **1648** may take other forms as well.

Sensor fusion algorithm **1650** may be an algorithm (or a computer program product storing an algorithm) configured to accept data from sensor system **1604** as input. The data may include, for example, data representing information sensed at the sensors of sensor system **1604**. Sensor fusion algorithm **1650** may include, for instance, a Kalman filter, Bayesian network, or other algorithm. Sensor fusion algorithm **1650** may further provide various assessments based on the data from sensor system **1604**. In an example embodi-

ment, the assessments may include evaluations of individual objects and/or features in the environment of autonomous vehicle **1600**, evaluation of a particular situation, and/or evaluate possible impacts based on the particular situation. Sensor fusion algorithm **1650** may operate in conjunction with stuck condition detector **1640**, trajectory validation system **1642**, and/or other components of autonomous vehicle **1600**.

Computer vision system **1652** may be any system operable to process and analyze images captured by camera **1630** in order to identify objects and/or features in the environment of autonomous vehicle **1600** that may include traffic signals, road way boundaries, and obstacles. Computer vision system **1652** may use an object recognition algorithm, a Structure from Motion (SFM) algorithm, video tracking, and other computer vision techniques. In some embodiments, computer vision system **1652** may be additionally configured to map an environment, track objects, estimate the speed of objects, etc. Computer vision system **1652** may operate in conjunction with stuck condition detector **1640**, trajectory validation system **1642**, and/or other components of autonomous vehicle **1600**.

Navigation and pathing system **1654** may be any system configured to determine a driving path for autonomous vehicle **1600**. Navigation and pathing system **1654** may additionally be configured to update the driving path dynamically while autonomous vehicle **1600** is in operation. In some embodiments, navigation and pathing system **1654** may be configured to incorporate data from sensor fusion algorithm **1650**, GPS **1620**, and one or more predetermined maps so as to determine a trajectory for autonomous vehicle **1600**.

Obstacle avoidance system **1656** may represent a control system configured to identify, evaluate, and avoid or otherwise negotiate potential obstacles in the environment of autonomous vehicle **1600**. Peripherals **1608** may be configured to allow interaction between autonomous vehicle **1600** and external sensors, other vehicles, other computer systems, and/or a user. For example, peripherals **1608** may include a communication system (comms) **1660**, a touchscreen **1662**, a microphone **1664**, a speaker **1666**, and/or a light source **1668**.

Peripherals **1608** may provide, for instance, an interface for a user of autonomous vehicle **1600** to interact with autonomous vehicle **1600**. To this end, touchscreen **1662** may provide information to a user of autonomous vehicle **1600**. Touchscreen **1662** may also be configured to sense at least one of a position and a movement of a user's finger via capacitive sensing, resistance sensing, or a surface acoustic wave process, among other possibilities. Touchscreen **1662** may be capable of sensing finger movement in a direction parallel or planar to the touchscreen surface, in a direction normal to the touchscreen surface, or both, and may also be capable of sensing a level of pressure applied to the touchscreen surface. Touchscreen **1662** may be formed of one or more translucent or transparent insulating layers and one or more translucent or transparent conducting layers. Touchscreen **1662** may take other forms as well.

Peripherals **1608** may also provide facilitate communication between autonomous vehicle **1600** and devices within its environment. The microphone **1664** may be configured to receive audio (e.g., a voice command or other audio input) from a user of autonomous vehicle **1600**. Similarly, speakers **1666** may be configured to output audio to the autonomous user of autonomous vehicle **1600**.

Communication system **1660** may be a wireless communication system configured to wirelessly communicate with

one or more devices directly or via a communication network. For example, communication system **1660** may use 3G cellular communication, such as Code-Division Multiple Access (CDMA), Evolution Data-Only (EVDO), or Universal Mobile Telecommunications System (UMTS), and/or 4G cellular communication, such as Worldwide Interoperability for Microwave Access (WiMAX) or Long Term Evolution (LTE). Alternatively, communication system **1660** may use a WLAN, for example, using WiFi. In some embodiments, communication system **1660** may communicate directly with a device, for example, using an infrared link, Bluetooth, or ZigBee. Other wireless protocols, such as various vehicular communication systems, are possible within the context of the disclosure. For example, communication system **1660** may include one or more dedicated short range communications (DSRC) devices that may include public and/or private data communications between vehicles and/or roadside stations. In some embodiments, communication system **1660** may be configured to communicate using wired communication.

Light source **1668** may generate and provide light to illuminate the environment of autonomous vehicle **1600**, and may include, but is not limited to, one or more headlights, taillights, indicators, fog lights, light bulbs, halogen lights, light emitting diodes (LEDs), turn signals, beams, and lighting assemblies.

Power supply **1670** may provide power to various components of autonomous vehicle **1600** and may represent, for example, a rechargeable lithium-ion or lead-acid battery. In some embodiments, one or more banks of such batteries may be configured to provide electrical power. Other power supply materials and configurations are possible. In some embodiments, power supply **1670** and energy source **1612** may be implemented together, as in some all-electric cars.

Many or all of the functions of vehicle **1600** may be controlled by a computing device **1680**. In some embodiments, computing device **1680** may include multiple computing devices. For example, computing device **1680** may control the function of autonomous vehicle **1600** based on inputs received from various systems (e.g., propulsion system **1602**, sensor system **1604**, and control system **1606**), as well as from peripherals **1608**. For example, computing device **1680** may utilize input from control system **1606** in order to control driving/steering unit **1654** to avoid an obstacle detected by sensor system **1604** and obstacle avoidance system **1656**.

In an example embodiment, computing device **1680** may control many aspects of autonomous vehicle **1600** and its systems. In another example embodiment, computing device **1680** may be configured to carry out part or all of the herein-described methods; e.g., methods **100**, **200**, **300**, **400**, **700**, and **1000** and/or perform some or all the autonomous vehicle functionality described herein. In some embodiments, computing device **1680** may be configured to store some or all of obstacle/object data **1630**, video data **1632**, and sensor data **1634**.

Although FIG. **16** shows various components of autonomous vehicle **1600**, such as communication system **1660** and computing device **1680**, as being integrated into autonomous vehicle **1600**, one or more of these components may be mounted or associated separately from autonomous vehicle **1600**. For example, computing device **1680** may, in part or in full, exist separate from autonomous vehicle **1600**. The device aspects that make up autonomous vehicle **1600** may be communicatively coupled together in a wired and/or wireless fashion.

Within the context of the present disclosure, the components of autonomous vehicle **1600** may be configured to work in an interconnected fashion with other components within or outside their respective systems. For instance, the camera **1628** may capture a plurality of images that may represent sensor data relating to an environment of autonomous vehicle **1600** operating in an autonomous mode. The environment may include another vehicle blocking a known traffic signal location ahead of autonomous vehicle **1600**. Based on the plurality of images, an inference system (which may include computing device **1680**, sensor system **1604**, and control system **1606**) may infer that the unobservable traffic signal is red based on sensor data from other aspects of the environment (for instance images indicating the blocking vehicle's brake lights are on). Based on the inference, computing device **1680** and propulsion system **1602** may act to control autonomous vehicle **1600**.

FIG. **17** shows a block diagram of components of an example assistance center **520**. Assistance center **520** may be configured with trajectory component **1702**, autonomous vehicle data component **1704**, storage component **1706**, and peripheral component **1708**. In some embodiments, assistance center **520** may have more, different, or fewer components than shown in FIG. **17**.

Trajectory component **1702** may include trajectory expert **1710**, trajectory specification component **1712**, and trajectory validation component **1714**. Trajectory expert **1710** may be configured to receive data from an autonomous vehicle in a stuck condition and determine a new trajectory for the autonomous vehicle to relieve the stuck condition. Trajectory expert **1710** may include a human expert, an expert system and/or other computer components configured for determining new trajectories, and/or a combination of human expert(s) and computer component(s). Trajectory specification component **1712** may be configured to enable trajectory expert **1710** to specify trajectories; e.g., receive a curve or points as input and generate a new trajectory as discussed above.

In some embodiments, an autonomous vehicle, such as autonomous vehicle **1600**, may propose new trajectories to relieve stuck conditions. In these embodiments, trajectory validation component **1714** may be used to verify whether a trajectory provided by an autonomous vehicle may relieve a stuck condition. In particular embodiments, trajectory validation component **1714** may be used to validate trajectories from other sources, such as another assistance center or a stored set of trajectory of trajectories **1732** to determine whether the other-sourced trajectory may relieve the stuck condition.

Autonomous vehicle data components **1704** include signal receiver **1720**, autonomous vehicle data receiver **1722**, and assistance response **1724**. Signal receiver **1720** may receive assistance signals, such as "heartbeat" signals and other signals from one or more autonomous vehicles. In some embodiments, signal receiver **1720** may be configured to receive periodic heartbeat signals from an autonomous vehicle informing assistance center **520** about a status of the autonomous vehicle. In some embodiments, assistance signals may be carried as part of heartbeat signals. Autonomous vehicle data receiver **1722** may receive data, such as but not limited to, sensor data, video data, audio data, object/obstacle information, and location data, from autonomous vehicle(s) contacting assistance center **520**. Signal receiver **1720** and autonomous vehicle data receiver **1722** may be configured to store respective signals and data in storage components **1706**.

Storage components may include representations of stored signals and data **1730** and trajectories **1732**. Stored signals and data **1730** and trajectories **1732** may be configured so that trajectory expert **1710**, or another component of assistance center **520**, or even another assistance center, may query storage components **1706** to search for trajectories based on various criteria. These criteria may include, but are not limited to, a physical location, similarity to another trajectory, and/or how recently the stored trajectory was used. One or more trajectories found by such a search may be considered for use by an autonomous vehicle.

Peripheral components **1708** include communications components **1740** for communicating at least with autonomous vehicles as described herein, a graphical user interface (GUI) **1742** for displaying output displays (perhaps with a touch screen for receiving touch-based input), and trajectory user interface **1744** for use, e.g., by trajectory expert **1710**, for specifying trajectories to trajectory specification component **1712** and/or trajectory validation component **1714**. Other peripherals, such as keyboard(s), speaker(s), computer mice, additional displays, and/or printers, may be components of assistance center **520**. In some embodiments, GUI **1742** may include or be replaced by a text or command-based user interface. GUI **1742** may display the screens shown in FIGS. **15A**, **15B**, and **15C**, and may also support the function described in the context of these figures.

FIG. **18** depicts an autonomous vehicle **1800** that may be capable of carrying out one or more of the functions, methods, and/or processes described herein. For instance, autonomous vehicle **1800** may be similar or identical to autonomous vehicle **1600**. Although autonomous vehicle **1800** is illustrated in FIG. **18** as a car, other embodiments are possible. For instance, autonomous vehicle **1800** may represent a truck, a van, a semi-trailer truck, a motorcycle, a golf cart, an off-road vehicle, or a farm vehicle, among other examples.

In some embodiments, autonomous vehicle **1800** may include a sensor unit **1802**, a wireless communication system **1804**, a LIDAR unit **1806**, a laser rangefinder unit **1808**, a camera **1810**, and light sources **1812a**, **1812b**, **1812c**, **1812d**. The aspects of autonomous vehicle **1800** may include some or all of the aspects described for FIG. **16**.

The sensor unit **1802** may include one or more different sensors configured to capture information about an environment of autonomous vehicle **1800**. For example, sensor unit **1802** may include any combination of camera units, radar units, LIDAR units, range finders, and acoustic sensors. Other types of sensors are possible.

In an example embodiment, the sensor unit **1802** may include one or more movable mounts that may be operable to adjust the orientation of one or more sensors in the sensor unit **1802**. In one embodiment, the movable mount may include a rotating platform that may scan sensors so as to obtain information from each direction around autonomous vehicle **1800**. In another embodiment, the movable mount of the sensor unit **1802** may be movable in a scanning fashion within a particular range of angles and/or azimuths. The sensor unit **1802** may be mounted atop the roof of a car, for instance, however other mounting locations are possible. Additionally, the sensors of sensor unit **1802** may be distributed in different locations and might not be collocated in a single location. Some possible sensor types and mounting locations include LIDAR unit **1806** and laser rangefinder unit **1808**. Furthermore, each sensor of sensor unit **1802** may be configured to be moved or scanned independently of other sensors of sensor unit **1802**.

Wireless communication system **1804** may be located on a roof of autonomous vehicle **1800** as depicted in FIG. **18**. Alternatively, wireless communication system **1804** may be located, fully or in part, elsewhere. Wireless communication system **1804** may include wireless transmitters and receivers that may be configured to communicate with devices external or internal to autonomous vehicle **1800**. Specifically, wireless communication system **1804** may include transceivers configured to communicate with other vehicles and/or computing devices, for instance, in a vehicular communication system or a roadway station. Examples of such vehicular communication systems include wide-area wireless communication system (such as 3G and/or 4G cellular systems), WLAN systems, GPS systems, dedicated short range communications (DSRC), radio frequency identification (RFID), and other proposed communication standards directed towards intelligent transport systems.

Camera **1810** may be any camera (e.g., a still camera, a video camera, etc.) configured to capture a plurality of images of the environment of autonomous vehicle **1800**. To this end, camera **1810** may be configured to detect visible light, or may be configured to detect light from other portions of the spectrum, such as infrared or ultraviolet light. Other types of cameras are possible as well.

Camera **1810** may be a two-dimensional detector, or may have a three-dimensional spatial range. In some embodiments, camera **1810** may be, for example, a range detector configured to generate a two-dimensional image indicating a distance from camera **1810** to a number of points in the environment. To this end, camera **1810** may use one or more range detecting techniques. For example, camera **1810** may use a structured light technique in which autonomous vehicle **1800** illuminates an object in the environment with a predetermined light pattern, such as a grid or checkerboard pattern and uses camera **1810** to detect a reflection of the predetermined light pattern off the object. Based on distortions in the reflected light pattern, autonomous vehicle **1800** may determine the distance to the points on the object. The predetermined light pattern may include infrared light, or light of another wavelength.

Camera **1810** may be mounted inside a front windshield of autonomous vehicle **1800**. Specifically, as illustrated, camera **1810** may capture images from a forward-looking view with respect to autonomous vehicle **1800**. Other mounting locations and viewing angles of camera **1810** are possible, either inside or outside autonomous vehicle **1800**.

Camera **1810** may have associated optics that may be operable to provide an adjustable field of view. Further, camera **1810** may be mounted to autonomous vehicle **1800** with a movable mount that may be operable to vary a pointing angle of camera **1810**. Camera **1810** may operate in conjunction with one or more of light sources **1812a**, **1812b**, **1812c**, **1812d**.

Each of light sources **1812a**, **1812b**, **1812c**, **1812d** may be a light source such as light source **1668** discussed above in the context of FIG. **16**. For example, each of light sources **1812a**, **1812b** may be a head light. Each head light may be configured to generate and provide white or nearly white light and project the (nearly) white light in front of autonomous vehicle **1800**. As another example, each of light sources **1812c**, **1812d** is a tail light. Each tail light may be configured to generate and provide yellow, red, and/or white light behind autonomous vehicle **1800**. Other example light sources are possible as well, including but not limited to, additional light sources, light sources configured to provide

different and/or additional colors of light, and light sources mounted in locations on autonomous vehicle **1800** other than shown in FIG. **18**.

FIG. **19A** is a block diagram of computing device **1900**, in accordance with an example embodiment. Computing device **1900** shown in FIG. **19A** could be configured to perform one or more functions of computing device **1680**, some or all of methods **100**, **200**, **300**, **400**, **700**, and **1000**, control some or all of the functionality of autonomous vehicles **510**, **512**, **514**, **610**, **810**, **1010**, **1110**, **1600**, and **1800**, and/or some or all of the functionality of assistance center **520**. Computing device **1900** may include a user interface module **1901**, a network-communication interface module **1902**, one or more processors **1903**, and data storage **1904**, all of which may be linked together via a system bus, network, or other connection mechanism **1905**.

User interface module **1901** may be operable to send data to and/or receive data from external user input/output devices. For example, user interface module **1901** may be configured to send and/or receive data to and/or from user input devices such as a keyboard, a keypad, a touch screen, a computer mouse, a track ball, a joystick, a camera, a voice recognition module, and/or other similar devices. User interface module **1901** may also be configured to provide output to user display devices, such as one or more cathode ray tubes (CRT), liquid crystal displays (LCD), light emitting diodes (LEDs), displays using digital light processing (DLP) technology, printers, light bulbs, and/or other similar devices, either now known or later developed. User interface module **1901** may also be configured to generate audible output(s), such as a speaker, speaker jack, audio output port, audio output device, earphones, and/or other similar devices.

Network-communications interface module **1902** may include one or more wireless interfaces **1907** and/or one or more wireline interfaces **1908** that are configurable to communicate via a network. Wireless interfaces **1907** may include one or more wireless transmitters, receivers, and/or transceivers, such as a Bluetooth transceiver, a Zigbee transceiver, a WLAN transceiver, a WWAN transceiver, and/or other similar type of wireless transceiver configurable to communicate via a wireless network. Wireline interfaces **1908** may include one or more wireline transmitters, receivers, and/or transceivers, such as an Ethernet transceiver, a Universal Serial Bus (USB) transceiver, or similar transceiver configurable to communicate via a twisted pair wire, a coaxial cable, a fiber-optic link, or a similar physical connection to a wireline network.

In some embodiments, network communications interface module **1902** may be configured to provide reliable, secured, and/or authenticated communications. For each communication described herein, information for ensuring reliable communications (i.e., guaranteed message delivery) may be provided, perhaps as part of a message header and/or footer (e.g., packet/message sequencing information, encapsulation header(s) and/or footer(s), size/time information, and transmission verification information such as cyclic redundancy check (CRC) and/or parity check values). Communications may be made secure (e.g., be encoded or encrypted) and/or decrypted/decoded using one or more cryptographic protocols and/or algorithms, such as, but not limited to, the Data Encryption Standard (DES), the Advanced Encryption Standard (AES), Rivest-Shamir-Adleman (RSA), Diffie-Hellman, and/or other techniques. Thus, various cryptographic protocols and/or algorithms may be used to secure (and then decrypt/decode) communications.

Processors **1903** may include one or more general purpose processors and/or one or more special purpose processors (e.g., digital signal processors, application specific integrated circuits, etc.). Processors **1903** may be configured to execute computer-readable program instructions **1906** that are contained in data storage **1904** and/or other instructions as described herein.

Data storage **1904** may include one or more computer-readable storage media that may be read and/or accessed by at least one of processors **1903**. The one or more computer-readable storage media may include volatile and/or non-volatile storage components, such as optical, magnetic, organic or other memory or disc storage, which may be integrated in whole or in part with at least one of processors **1903**. In some embodiments, data storage **1904** may be implemented using a single physical device (e.g., one optical, magnetic, organic or other memory or disc storage unit), while in other embodiments, data storage **1904** may be implemented using two or more physical devices.

Data storage **1904** may include computer-readable program instructions **1906**, and perhaps additional data. In some embodiments, data storage **1904** may additionally include storage used to perform at least part of the herein-described methods and techniques and/or at least part of the functionality of the herein-described devices and networks.

FIG. **19B** depicts a network **1914** of computing clusters **1909a**, **1909b**, **1909c** arranged as server system, in accordance with an example embodiment. Computing devices **1680** and/or **1900** may be included in such a cluster. In some embodiments, computing devices **1680** and/or **1900** may be a single computing devices residing in a single computing center; e.g., within autonomous vehicle **1600**. In other embodiments, computing devices **1680** and/or **1900** may include multiple computing devices in a single computing center, or even multiple computing devices located in multiple computing centers located in diverse geographic locations.

In some embodiments, data and services at computing devices **1680** and/or **1900** may be encoded as computer readable information stored in non-transitory, tangible computer readable media (or computer readable storage media) and accessible by programmable devices, such as mobile devices, laptop or desktop computers, smart phones, and/or other computing devices. In some embodiments, data at computing devices **1680** and/or **1900** may be stored on a single disk drive or other tangible storage media, or may be implemented on multiple disk drives or other tangible storage media located at one or more diverse geographic locations.

FIG. **19B** depicts a server system in accordance with an example embodiment. In FIG. **19B**, the functions of computing devices **1680** and/or **1900** may be distributed among three computing clusters **1909a**, **1909b**, and **1909c**. Computing cluster **1909a** may include one or more computing devices **1900a**, cluster storage arrays **1910a**, and cluster routers **1911a** connected by a local cluster network **1912a**. Similarly, computing cluster **1909b** may include one or more computing devices **1900b**, cluster storage arrays **1910b**, and cluster routers **1911b** connected by a local cluster network **1912b**. Likewise, computing cluster **1909c** may include one or more computing devices **1900c**, cluster storage arrays **1910c**, and cluster routers **1911c** connected by a local cluster network **1912c**.

In some embodiments, each of computing clusters **1909a**, **1909b**, and **1909c** may have an equal number of computing devices, an equal number of cluster storage arrays, and an equal number of cluster routers. In other embodiments,

however, each computing cluster may have different numbers of computing devices, different numbers of cluster storage arrays, and different numbers of cluster routers. The number of computing devices, cluster storage arrays, and cluster routers in each computing cluster may depend on the computing task or tasks assigned to each computing cluster.

In computing cluster **1909a**, for example, computing devices **1900a** may be configured to perform various computing tasks of computing devices **1680** and/or **1900**. In one embodiment, the various functionalities of computing devices **1680** and/or **1900** may be distributed among one or more of computing devices **1900a**, **1900b**, and **1900c**. Computing devices **1900b** and **1900c** in computing clusters **1909b** and **1909c** may be configured similarly to computing devices **1900a** in computing cluster **1909a**. On the other hand, in some embodiments, computing devices **1900a**, **1900b**, and **1900c** may be configured to perform different functions.

In some embodiments, computing tasks and stored data associated with computing devices **1680** and/or **1900** may be distributed across computing devices **1900a**, **1900b**, and **1900c** based at least in part on the processing capacity of computing devices **1680** and/or **1900**, the processing capabilities of computing devices **1900a**, **1900b**, and **1900c**, the latency of the network links between the computing devices in each computing cluster and between the computing clusters themselves, and/or other factors that may contribute to the cost, speed, fault-tolerance, resiliency, efficiency, and/or other design goals of the overall system architecture.

The cluster storage arrays **1910a**, **1910b**, and **1910c** of the computing clusters **1909a**, **1909b**, and **1909c** may be data storage arrays that include disk array controllers configured to manage read and write access to groups of hard disk drives. The disk array controllers, alone or in conjunction with their respective computing devices, may also be configured to manage backup or redundant copies of the data stored in the cluster storage arrays to protect against disk drive or other cluster storage array failures and/or network failures that prevent one or more computing devices from accessing one or more cluster storage arrays.

Similar to the manner in which the functions of computing devices **1680** and/or **1900** may be distributed across computing devices **1900a**, **1900b**, and **1900c** of computing clusters **1909a**, **1909b**, and **1909c**, various active portions and/or backup portions of these components may be distributed across cluster storage arrays **1910a**, **1910b**, and **1910c**. For example, some cluster storage arrays may be configured to store the data of one or more computing device(s) **1680** and/or **1900**, while other cluster storage arrays may store data of other computing device(s) **1680** and/or **1900**. Additionally, some cluster storage arrays may be configured to store backup versions of data stored in other cluster storage arrays.

Cluster routers **1911a**, **1911b**, and **1911c** in computing clusters **1909a**, **1909b**, and **1909c** may include networking equipment configured to provide internal and external communications for the computing clusters. For example, cluster routers **1911a** in computing cluster **1909a** may include one or more internet switching and routing devices configured to provide (i) local area network communications between computing devices **1900a** and cluster storage arrays **1901a** via local cluster network **1912a**, and (ii) wide area network communications between computing cluster **1909a** and computing clusters **1909b** and **1909c** via wide area network connection **1913a** to network **1914**. Cluster routers **1911b** and **1911c** may include network equipment similar to cluster routers **1911a**, and cluster routers **1911b** and **1911c** may

perform similar networking functions for computing clusters **1909b** and **1909b** that cluster routers **1911a** perform for computing cluster **1909a**.

In some embodiments, the configuration of cluster routers **1911a**, **1911b**, and **1911c** may be based at least in part on the data communication capacity of the computing devices and cluster storage arrays, the data communications capabilities of the network equipment in the cluster routers **1911a**, **1911b**, and **1911c**, the latency and throughput of local networks **1912a**, **1912b**, **1912c**, the latency, throughput, and cost of wide area network links **1913a**, **1913b**, and **1913c**, and/or other factors that may contribute to the cost, speed, fault-tolerance, resiliency, efficiency and/or other design goals of the moderation system architecture.

The above detailed description describes various features and functions of the disclosed systems, devices, and methods with reference to the accompanying figures. In the figures, similar symbols typically identify similar components, unless context indicates otherwise. The example embodiments described herein and in the figures are not meant to be limiting. Other embodiments may be utilized, and other changes may be made, without departing from the scope of the subject matter presented herein. It will be readily understood that the aspects of the present disclosure, as generally described herein, and illustrated in the figures, may be arranged, substituted, combined, separated, and designed in a wide variety of different configurations, all of which are explicitly contemplated herein.

With respect to any or all of the ladder diagrams, scenarios, and flow charts in the figures and as discussed herein, each block and/or communication may represent a processing of information and/or a transmission of information in accordance with example embodiments. Alternative embodiments are included within the scope of these example embodiments. In these alternative embodiments, for example, functions described as blocks, transmissions, communications, requests, responses, and/or messages may be executed out of order from that shown or discussed, including substantially concurrent or in reverse order, depending on the functionality involved. Further, more or fewer blocks and/or functions may be used with any of the ladder diagrams, scenarios, and flow charts discussed herein, and these ladder diagrams, scenarios, and flow charts may be combined with one another, in part or in whole.

A block that represents a processing of information may correspond to circuitry that may be configured to perform the specific logical functions of a herein-described method or technique. Alternatively or additionally, a block that represents a processing of information may correspond to a module, a segment, or a portion of program code (including related data). The program code may include one or more instructions executable by a processor for implementing specific logical functions or actions in the method or technique. The program code and/or related data may be stored on any type of computer readable medium such as a storage device including a disk or hard drive or other storage medium.

The computer readable medium may also include non-transitory computer readable media such as computer-readable media that stores data for short periods of time like register memory, processor cache, and random access memory (RAM). The computer readable media may also include non-transitory computer readable media that stores program code and/or data for longer periods of time, such as secondary or persistent long term storage, like read only memory (ROM), optical or magnetic disks, compact-disc read only memory (CD-ROM), for example. The computer

readable media may also be any other volatile or non-volatile storage systems. A computer readable medium may be considered a computer readable storage medium, for example, or a tangible storage device.

Moreover, a block that represents one or more information transmissions may correspond to information transmissions between software and/or hardware modules in the same physical device. However, other information transmissions may be between software modules and/or hardware modules in different physical devices.

The particular arrangements shown in the figures should not be viewed as limiting. It should be understood that other embodiments may include more or less of each element shown in a given figure. Further, some of the illustrated elements may be combined or omitted. Yet further, an example embodiment may include elements that are not illustrated in the figures.

While various aspects and embodiments have been disclosed herein, other aspects and embodiments will be apparent to those skilled in the art. The various aspects and embodiments disclosed herein are for purposes of illustration and are not intended to be limiting, with the true scope being indicated by the following claims.

What is claimed is:

1. A method comprising:

transmitting, by a transceiver of an autonomous vehicle, an assistance signal to an assistance center, wherein the assistance signal indicates that the autonomous vehicle seeks assistance while navigating according to a first trajectory;

receiving, by the transceiver of the autonomous vehicle, a request for navigational information from the assistance center;

transmitting, by the transceiver of the autonomous vehicle, the requested navigational information to the assistance center, wherein the requested navigational information indicates representations of objects in a vicinity of the autonomous vehicle; and

receiving, by the transceiver of the autonomous vehicle, a response to the assistance signal, wherein the response includes a representation of a second trajectory that intersects the first trajectory at one or more points, and wherein the transceiver is controlled by a processor of the autonomous vehicle to perform the transmitting and receiving.

2. The method of claim 1, wherein the second trajectory ignores a presence of at least one object that obstructs the first trajectory.

3. The method of claim 1, wherein the second trajectory is different from the first trajectory and the second trajectory intersects the first trajectory at two or more points.

4. The method of claim 1, wherein the navigational information comprises high-level, polyhedral representations of the objects that are based at least in part on low-level laser strike input.

5. The method of claim 1, wherein the navigational information comprises still images, video data, or audio data.

6. The method of claim 1, wherein the navigational information comprises a proposed trajectory that intersects the first trajectory at two or more points, wherein the proposed trajectory is generated by the autonomous vehicle.

7. The method of claim 6, wherein the second trajectory and the proposed trajectory are identical.

8. The method of claim 6, wherein the second trajectory comprises a modified version of the proposed trajectory.

41

9. The method of claim 1, wherein the autonomous vehicle is an automobile, and wherein at least one of the objects in the vicinity of the autonomous vehicle is an automobile traffic signal.

10. The method of claim 1, wherein the autonomous vehicle is an automobile, and wherein at least one of the objects in the vicinity of the autonomous vehicle is a roadway boundary.

11. An autonomous vehicle comprising:

at least one processor;

memory; and

program instructions, stored in the memory, that upon execution by the at least one processor cause the autonomous vehicle to perform operations comprising:

transmitting an assistance signal to an assistance center, wherein the assistance signal indicates that the autonomous vehicle seeks assistance while navigating according to a first trajectory;

receiving a request for navigational information from the assistance center;

transmitting the requested navigational information to the assistance center, wherein the requested navigational information indicates representations of objects in a vicinity of the autonomous vehicle; and

receiving a response to the assistance signal, wherein the response includes a representation of a second trajectory that intersects the first trajectory at one or more points.

12. The autonomous vehicle of claim 11, wherein the second trajectory ignores a presence of at least one object that obstructs the first trajectory.

13. The autonomous vehicle of claim 11, wherein the second trajectory is different from the first trajectory and the second trajectory intersects the first trajectory at two or more points.

14. The autonomous vehicle of claim 11, wherein the navigational information comprises high-level, polyhedral representations of the objects that are based at least in part on low-level laser strike input.

42

15. The autonomous vehicle of claim 11, wherein the navigational information comprises still images, video data, or audio data.

16. The autonomous vehicle of claim 11, wherein the navigational information comprises a proposed trajectory that intersects the first trajectory at two or more points, wherein the proposed trajectory is generated by the autonomous vehicle.

17. The autonomous vehicle of claim 16, wherein the second trajectory and the proposed trajectory are identical.

18. The autonomous vehicle of claim 16, wherein the second trajectory comprises a modified version of the proposed trajectory.

19. The autonomous vehicle of claim 11, wherein the autonomous vehicle is an automobile, and wherein at least one of the objects in the vicinity of the autonomous vehicle is an automobile traffic signal.

20. An article of manufacture including a non-transitory computer-readable medium, having stored thereon program instructions that, upon execution by a computing device of an autonomous vehicle, cause the autonomous vehicle to perform operations comprising:

transmitting an assistance signal to an assistance center, wherein the assistance signal indicates that the autonomous vehicle seeks assistance while navigating according to a first trajectory;

receiving a request for navigational information from the assistance center;

transmitting the requested navigational information to the assistance center, wherein the requested navigational information indicates representations of objects in a vicinity of the autonomous vehicle; and

receiving a response to the assistance signal, wherein the response includes a representation of a second trajectory that intersects the first trajectory at one or more points.

* * * * *