



US009929494B2

(12) **United States Patent**
Schmidt et al.

(10) **Patent No.:** **US 9,929,494 B2**
(45) **Date of Patent:** **Mar. 27, 2018**

(54) **ELECTRICAL CONNECTOR FOR
ATMOSPHERIC ISOLATION**

(71) Applicant: **Google LLC**, Mountain View, CA (US)

(72) Inventors: **Mathias Schmidt**, Emeryville, CA
(US); **Adam Mittleman**, Redwood City,
CA (US)

(73) Assignee: **Google LLC**, Mountain View, CA (US)

(*) Notice: Subject to any disclaimer, the term of this
patent is extended or adjusted under 35
U.S.C. 154(b) by 0 days.

(21) Appl. No.: **15/272,652**

(22) Filed: **Sep. 22, 2016**

(65) **Prior Publication Data**

US 2017/0012383 A1 Jan. 12, 2017

Related U.S. Application Data

(63) Continuation of application No. 14/713,589, filed on
May 15, 2015, now Pat. No. 9,478,882.

(51) **Int. Cl.**

H01R 13/52 (2006.01)
H01R 12/70 (2011.01)
G08B 17/10 (2006.01)
G08B 17/113 (2006.01)
H01R 13/627 (2006.01)
H01R 13/73 (2006.01)
G08B 17/103 (2006.01)
G08B 21/14 (2006.01)

(52) **U.S. Cl.**

CPC **H01R 13/5202** (2013.01); **G08B 17/10**
(2013.01); **G08B 17/113** (2013.01); **H01R**
12/7076 (2013.01); **H01R 13/52** (2013.01);
H01R 13/6272 (2013.01); **G08B 17/103**
(2013.01); **G08B 21/14** (2013.01); **H01R 13/73**
(2013.01)

(58) **Field of Classification Search**

CPC H01R 12/7076; H01R 13/73; H01R 13/74;
H01R 13/741; H01R 13/743; H01R
13/639; H01R 13/6392
USPC 439/353, 357, 78, 676, 767, 660, 566,
439/559

See application file for complete search history.

(56) **References Cited**

U.S. PATENT DOCUMENTS

4,257,039 A 3/1981 Webb et al.
4,653,835 A * 3/1987 Schulte H01R 13/523
439/277
5,015,200 A * 5/1991 Abernethy H01R 13/6271
439/357

6,113,424 A 9/2000 Shinozaki
6,508,666 B1 1/2003 Francis

(Continued)

Primary Examiner — Harshad C Patel

(74) *Attorney, Agent, or Firm* — Kilpatrick Townsend &
Stockton LLP

(57) **ABSTRACT**

An electrical connector that may include a socket body and
that includes four lateral walls, a rear wall, a catch feature
and a catch support. The lateral walls may adjoin one
another and the rear wall. The catch support may adjoin two
of the lateral walls along edges of the catch support to define
a catch cavity and a plug cavity on opposing sides of the
catch support. A first side of the rear wall may face the plug
cavity and a second side bounds a rear surface of the socket
body. The catch feature may couple with the catch support.
Electrical pins may pass through the rear wall of the socket
body such that one end of each of the pins is within the plug
cavity, and an opposing end of each of the pins extends away
from the rear surface of the socket body.

16 Claims, 11 Drawing Sheets

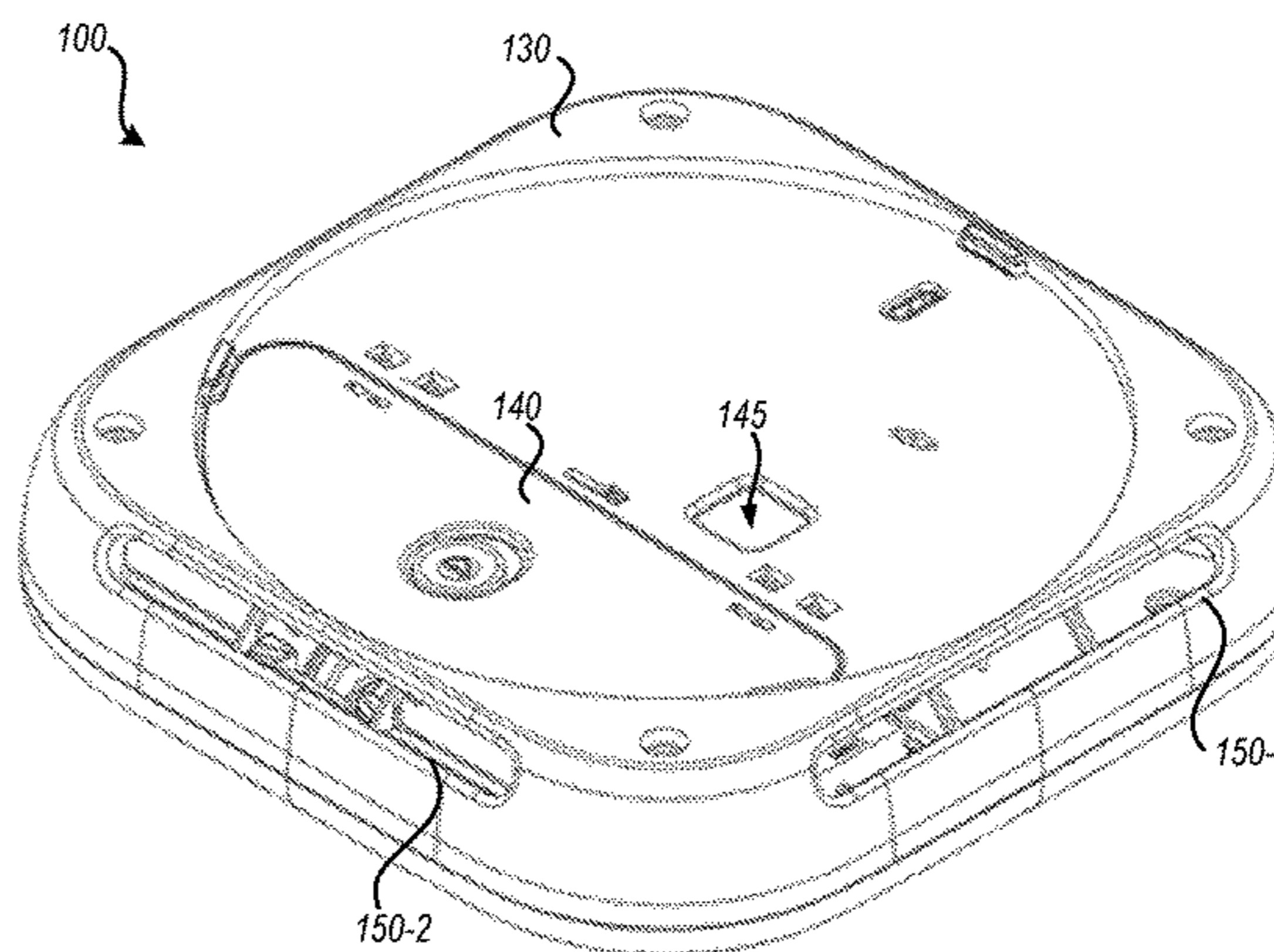
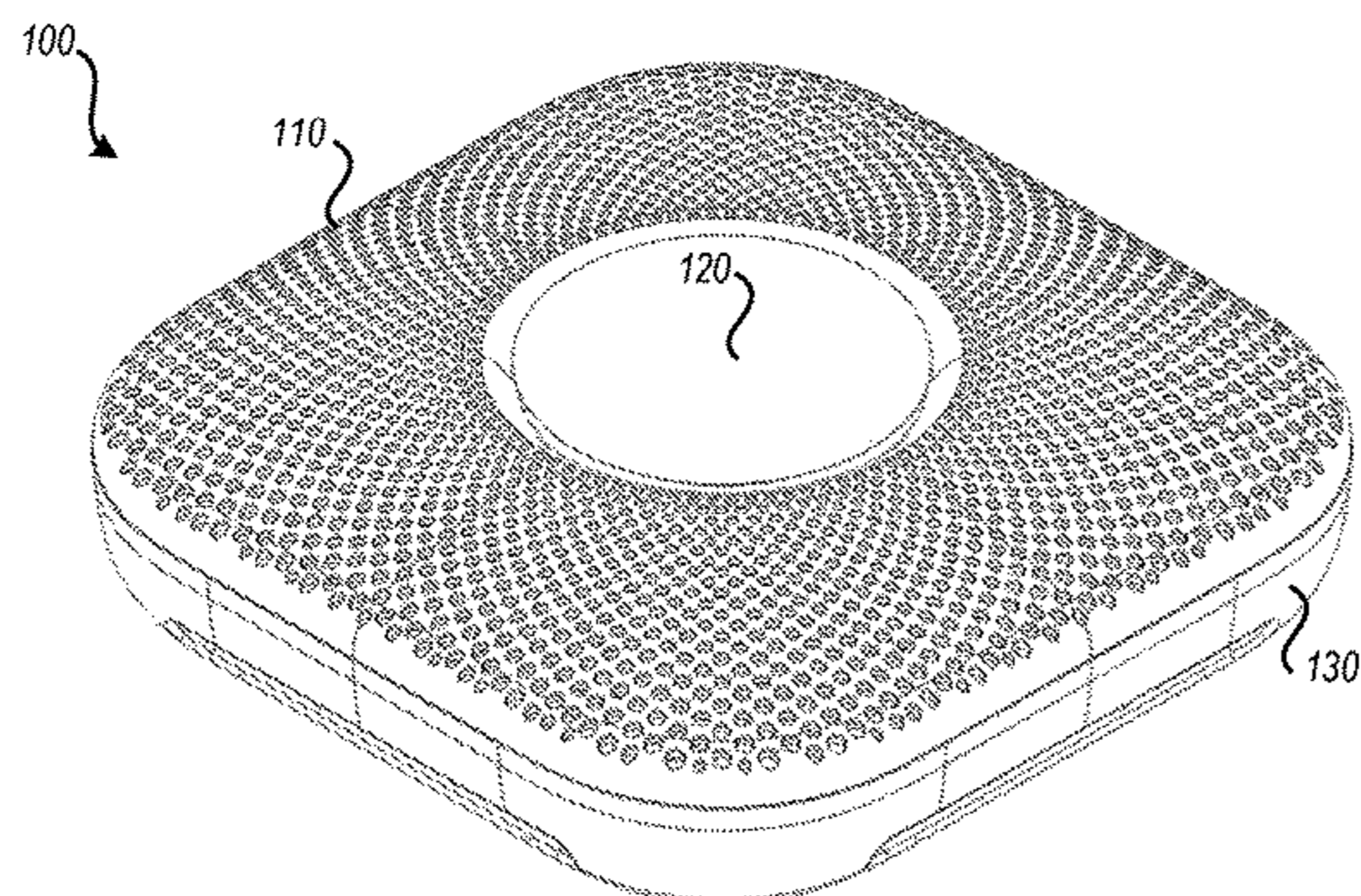

(56)

References Cited

U.S. PATENT DOCUMENTS

6,579,113 B2 *	6/2003	Kodama	H01R 13/6272 439/358
8,152,556 B2 *	4/2012	Wu	H01R 13/635 439/357
8,847,772 B2	9/2014	Marks et al.	
8,933,811 B2 *	1/2015	Hojmose	F21V 33/0076 340/630
9,478,882 B1	10/2016	Schmidt et al.	
2004/0005805 A1 *	1/2004	Shibata	H01R 13/6272 439/358
2004/0125571 A1	7/2004	Chen	
2008/0299811 A1 *	12/2008	Battista	H01R 13/6273 439/345
2010/0297864 A1 *	11/2010	Matsuoka	B29C 45/14639 439/271
2013/0093594 A1	4/2013	Brigham	

* cited by examiner

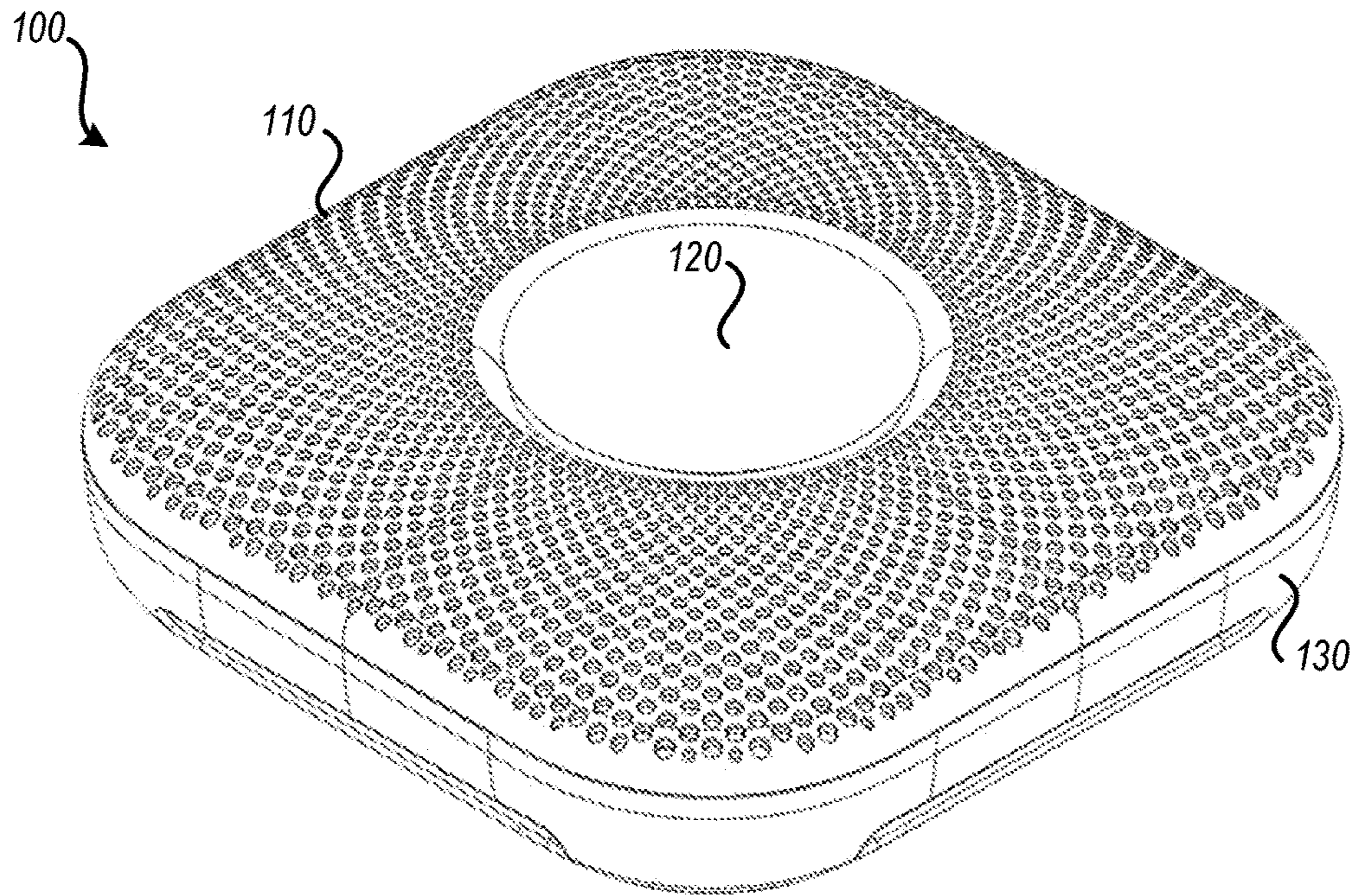

FIG. 1A

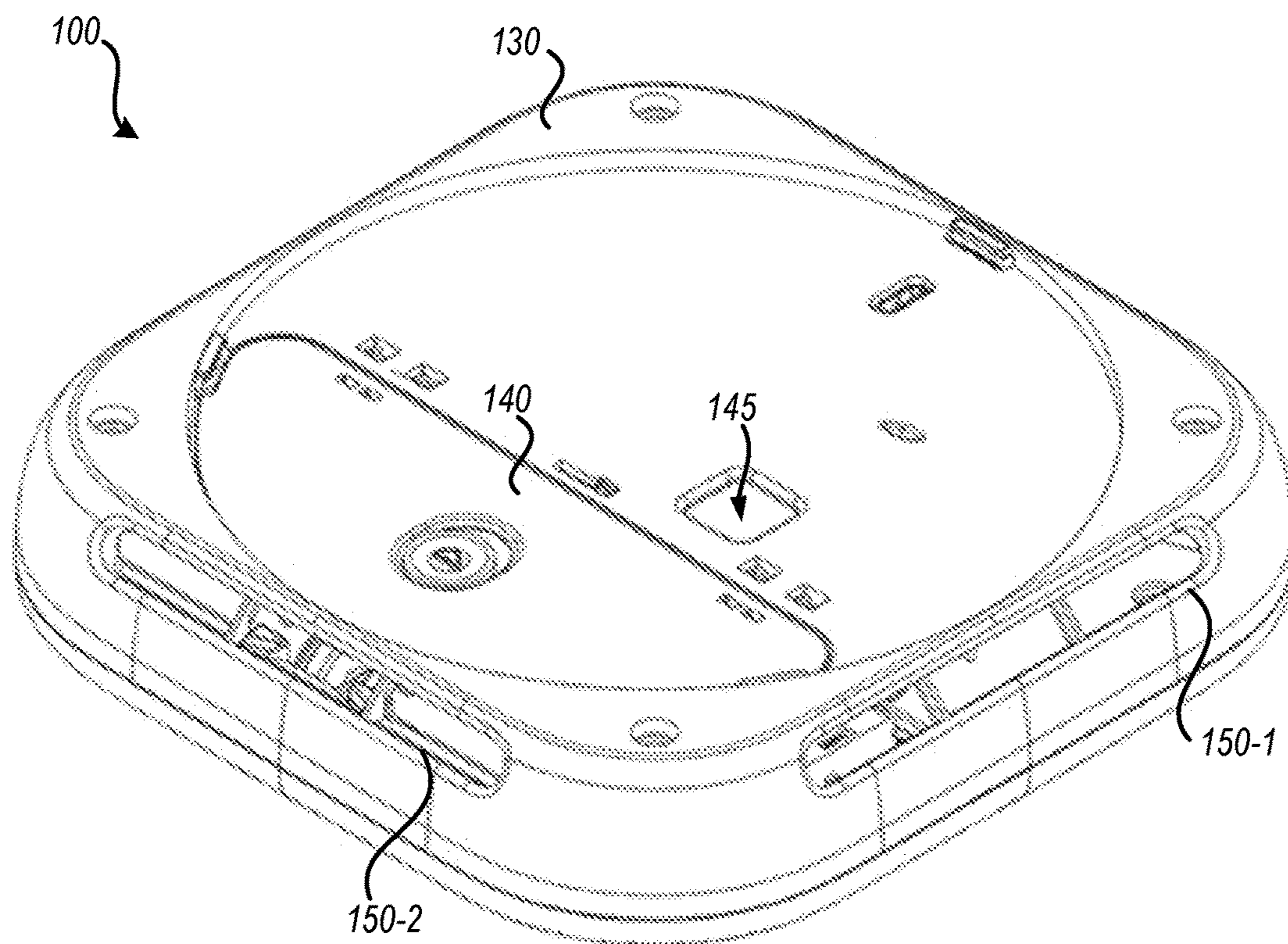

FIG. 1B

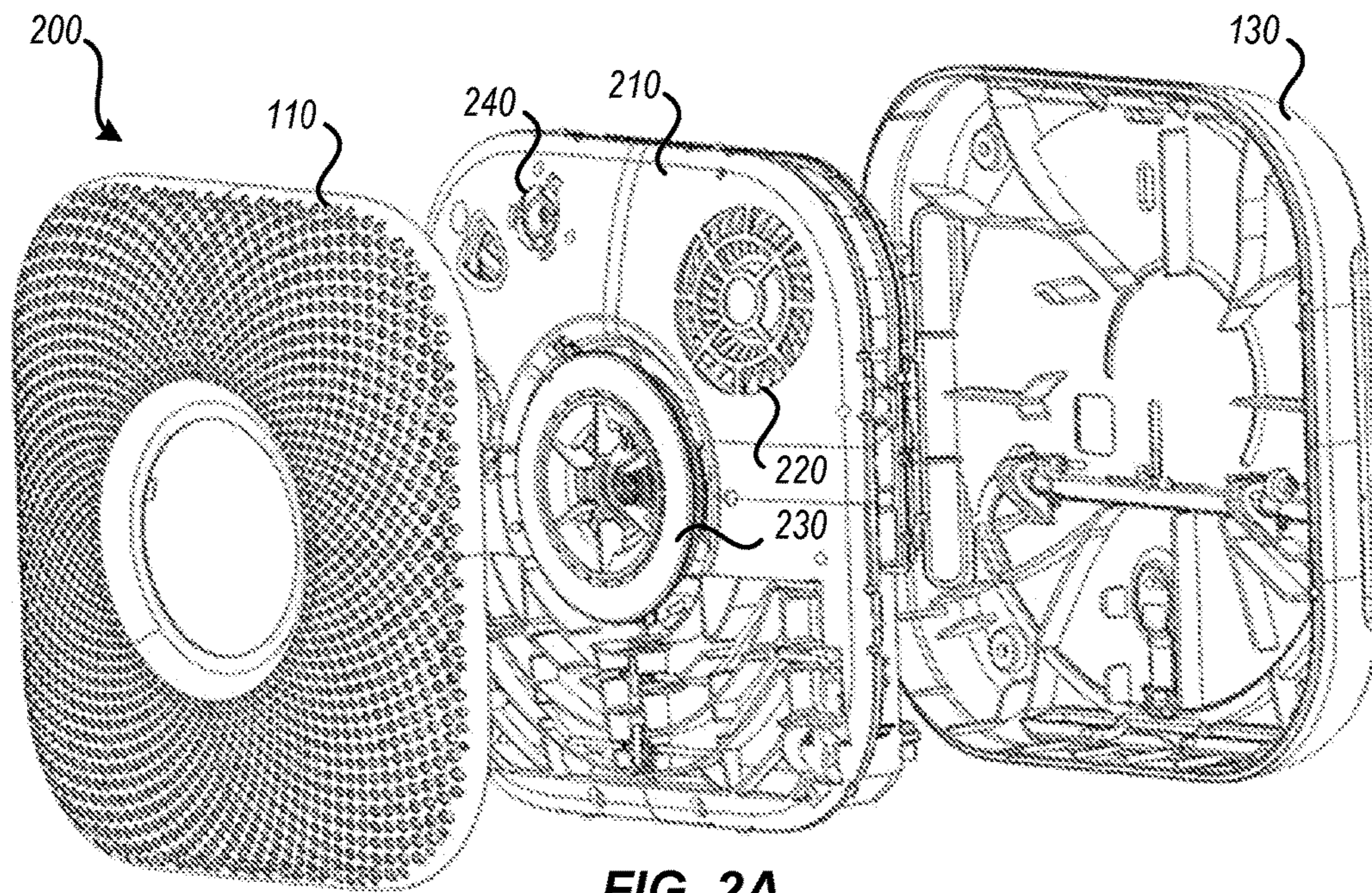

FIG. 2A

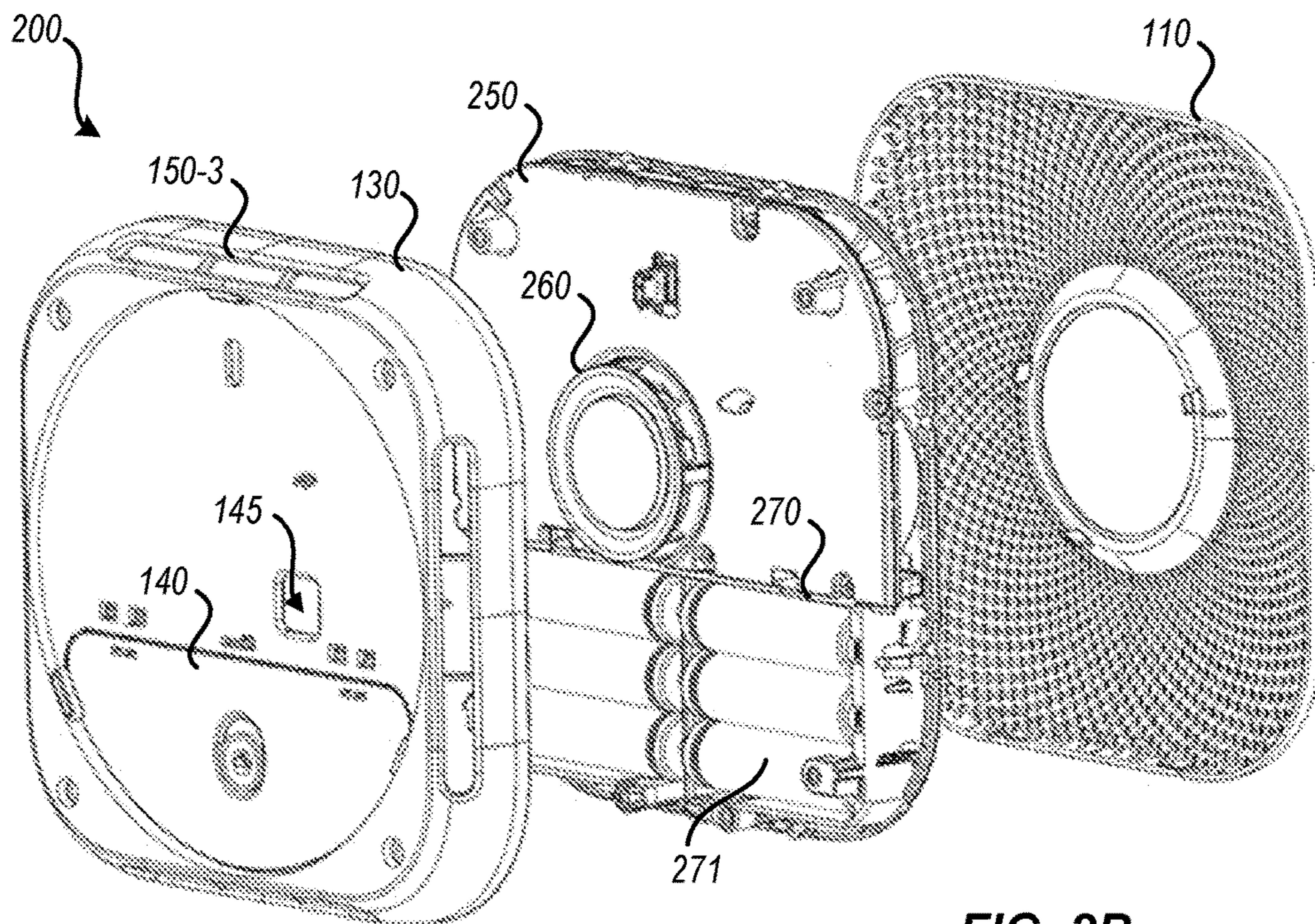

FIG. 2B

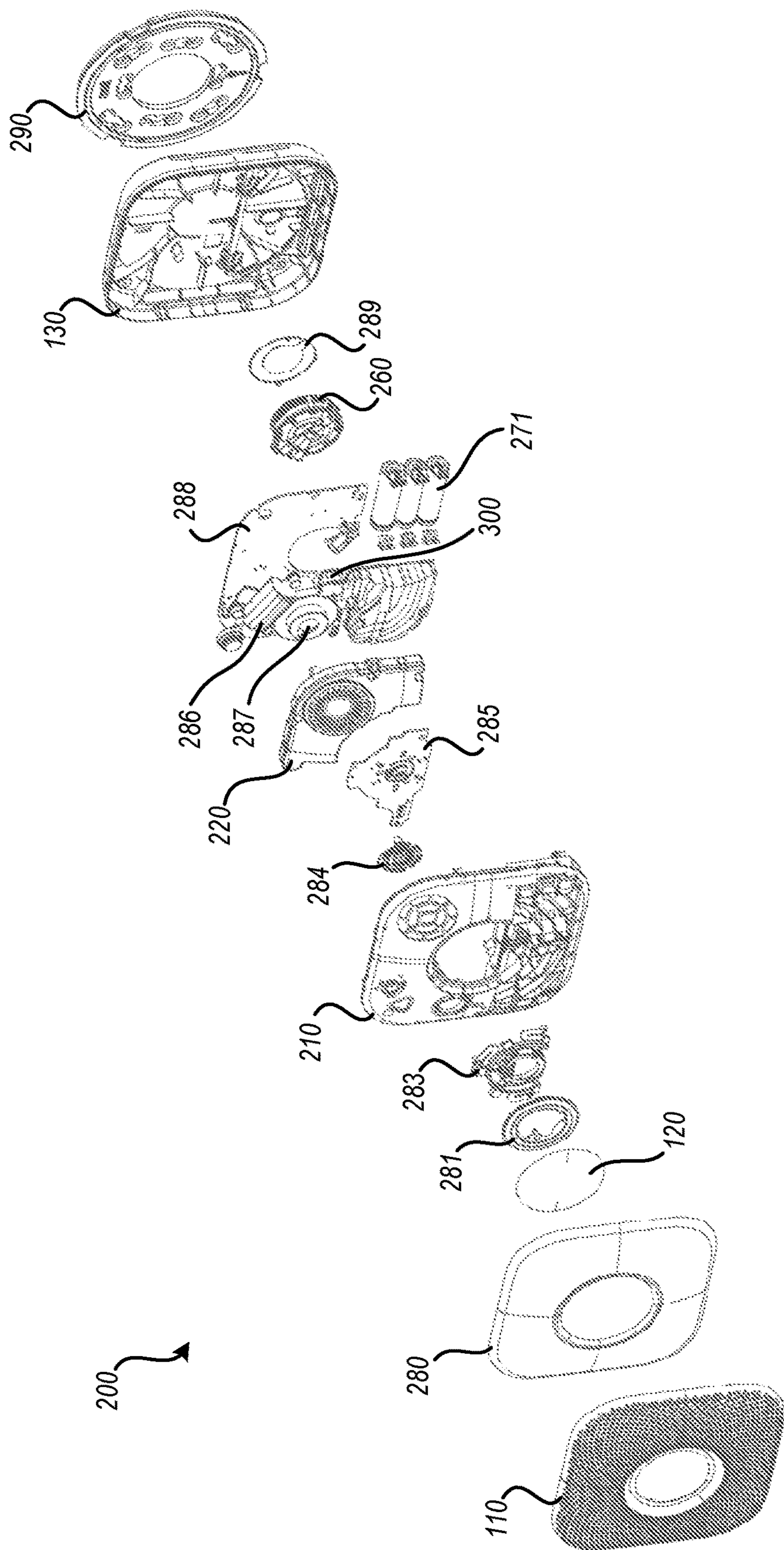

FIG. 2C

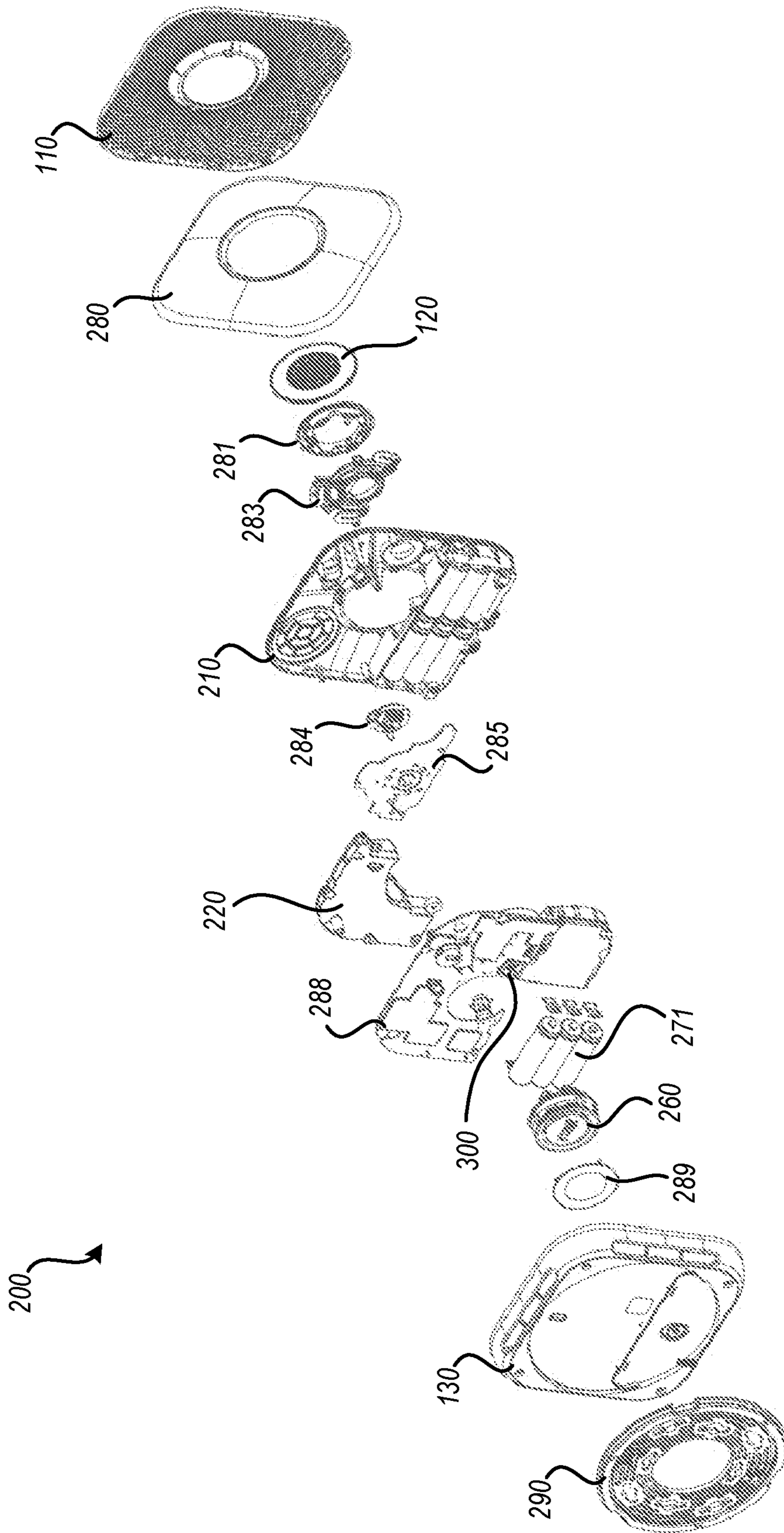

FIG. 2D

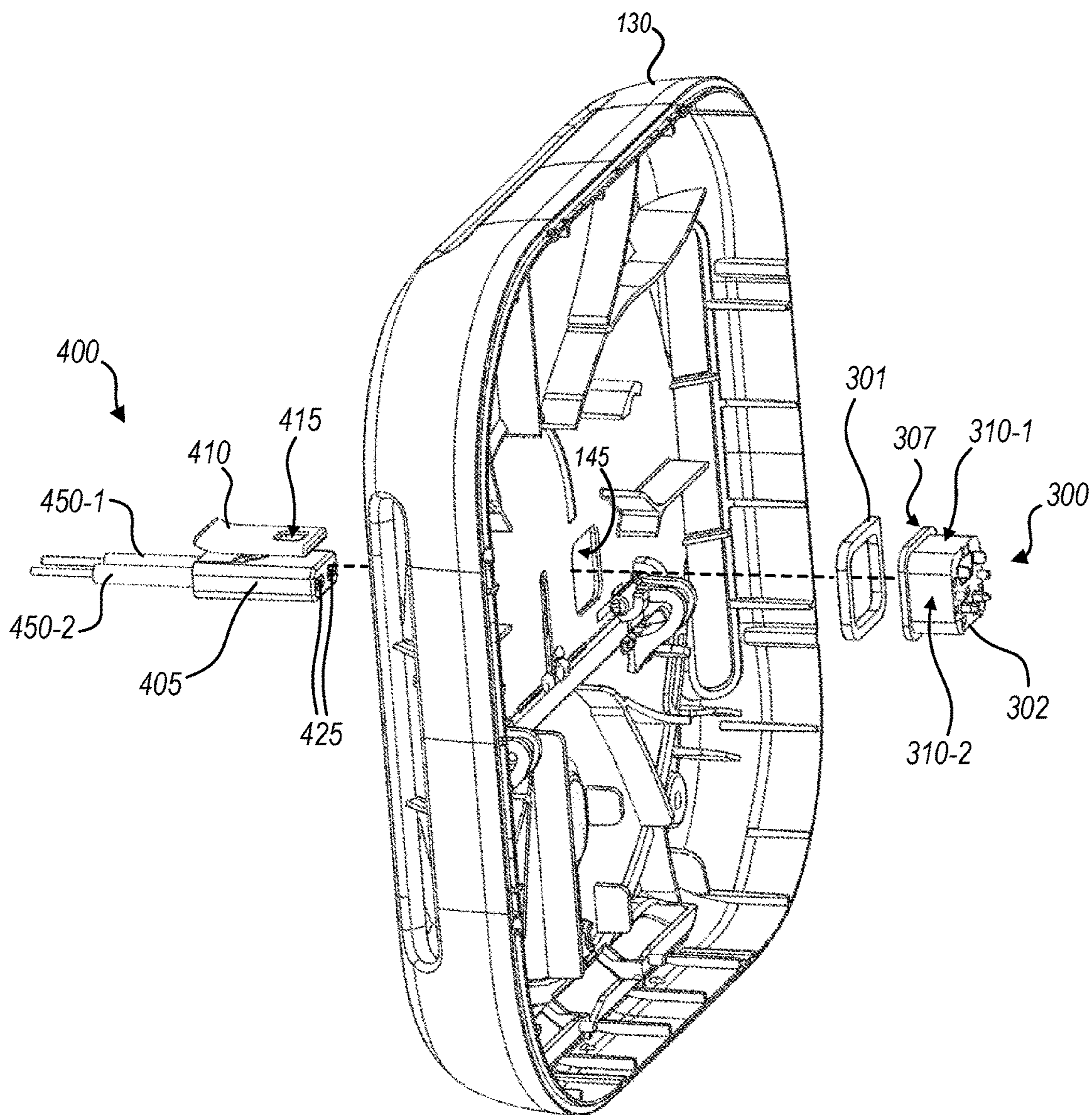
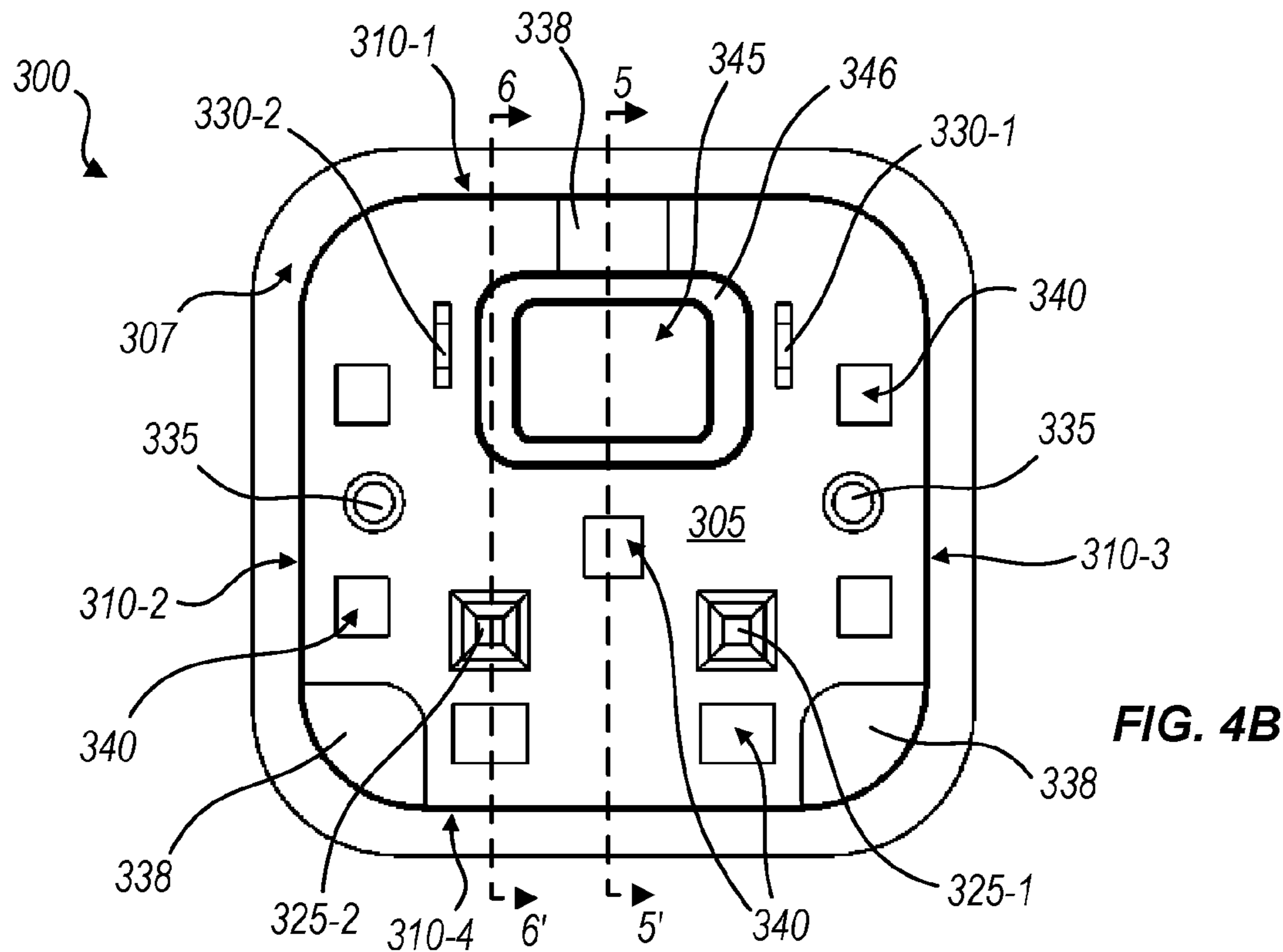
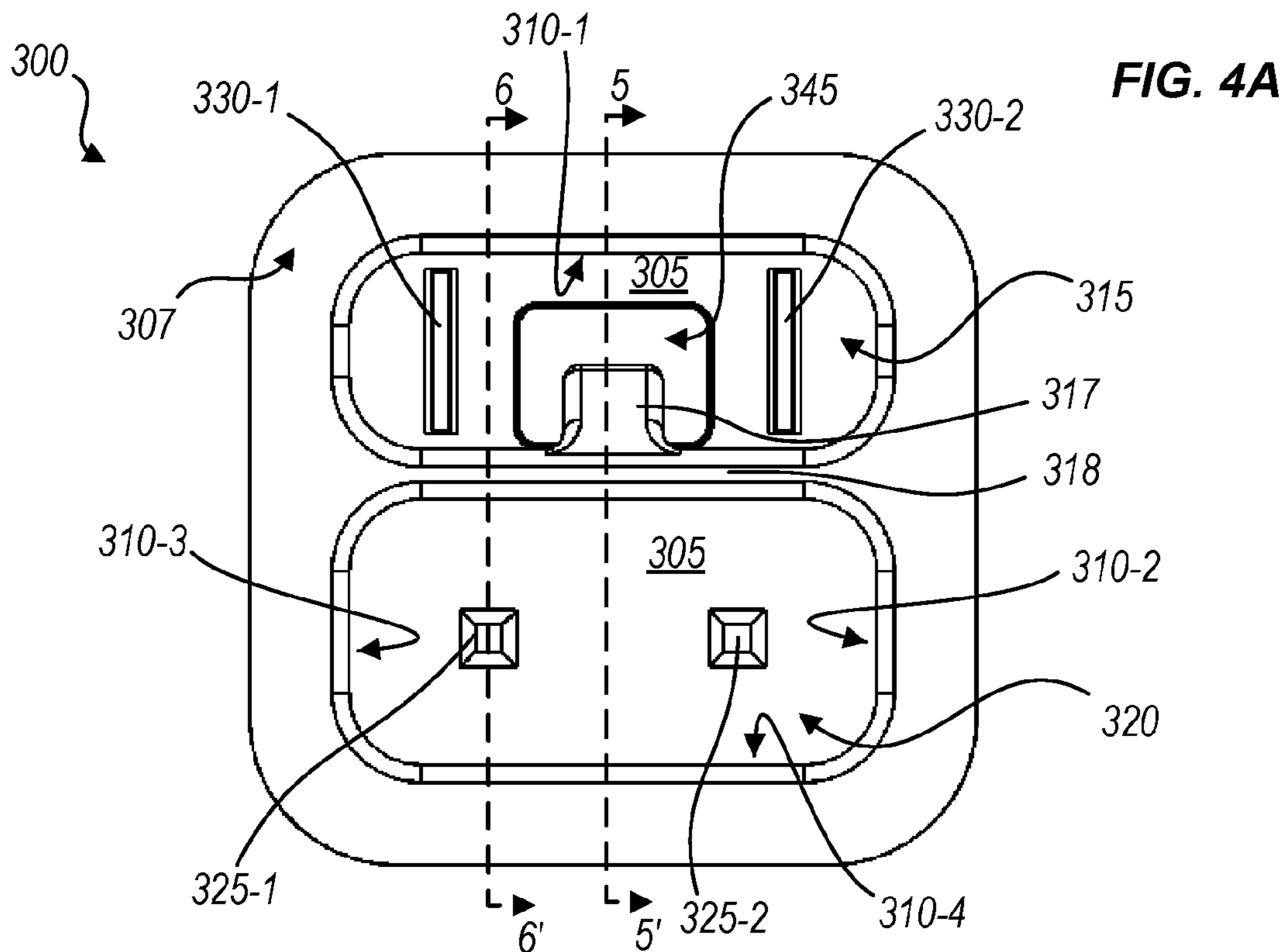
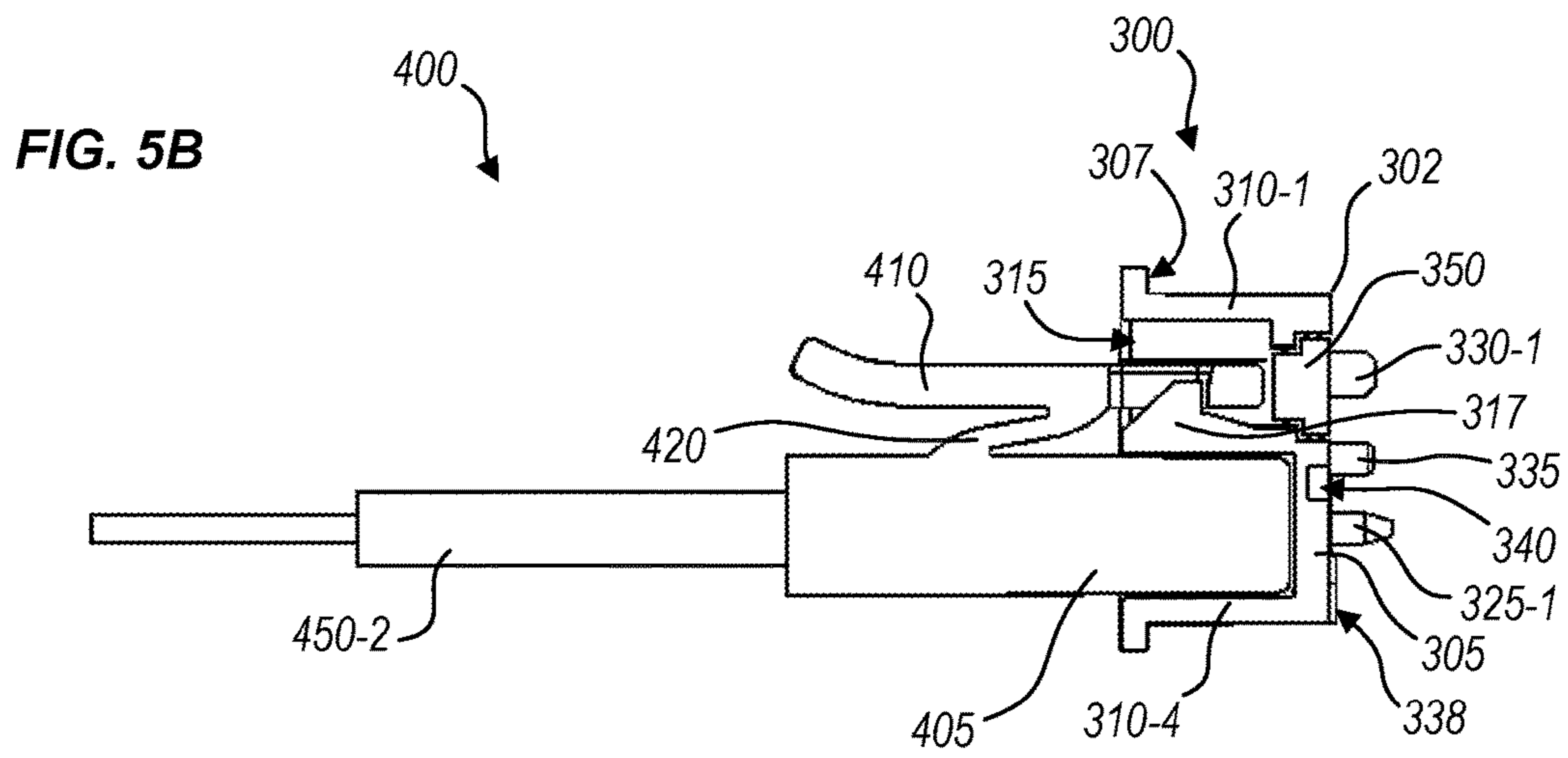
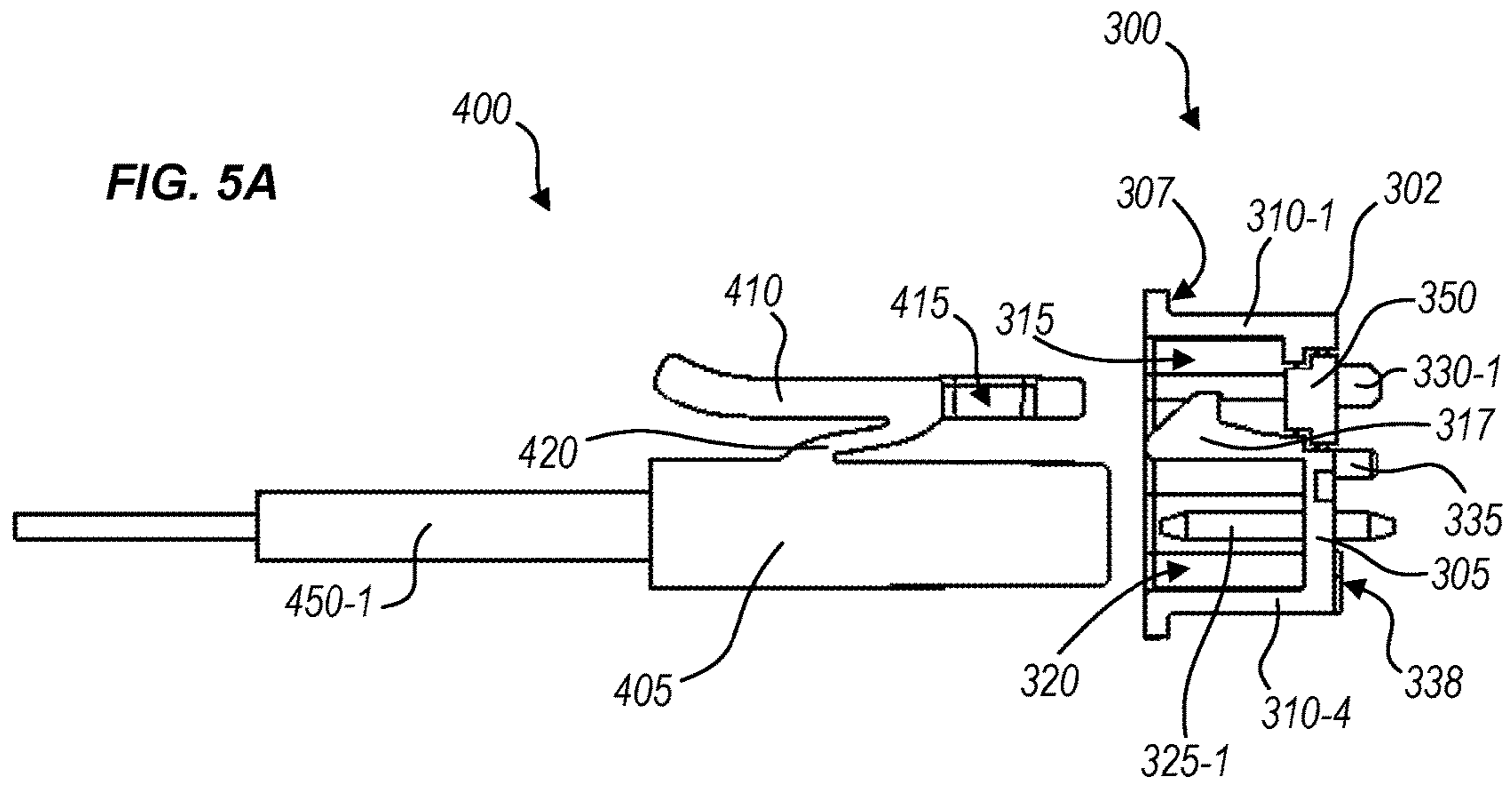
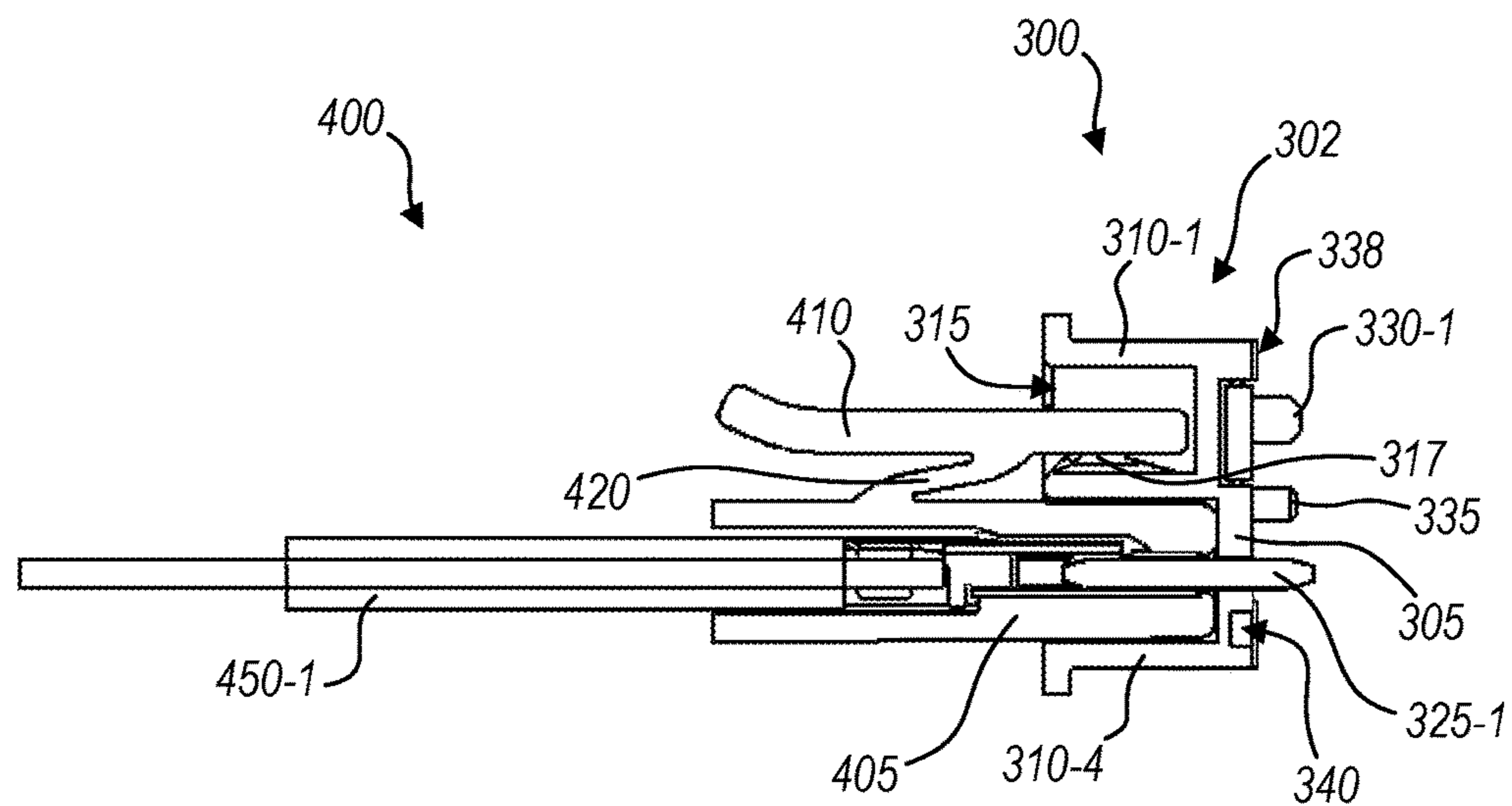
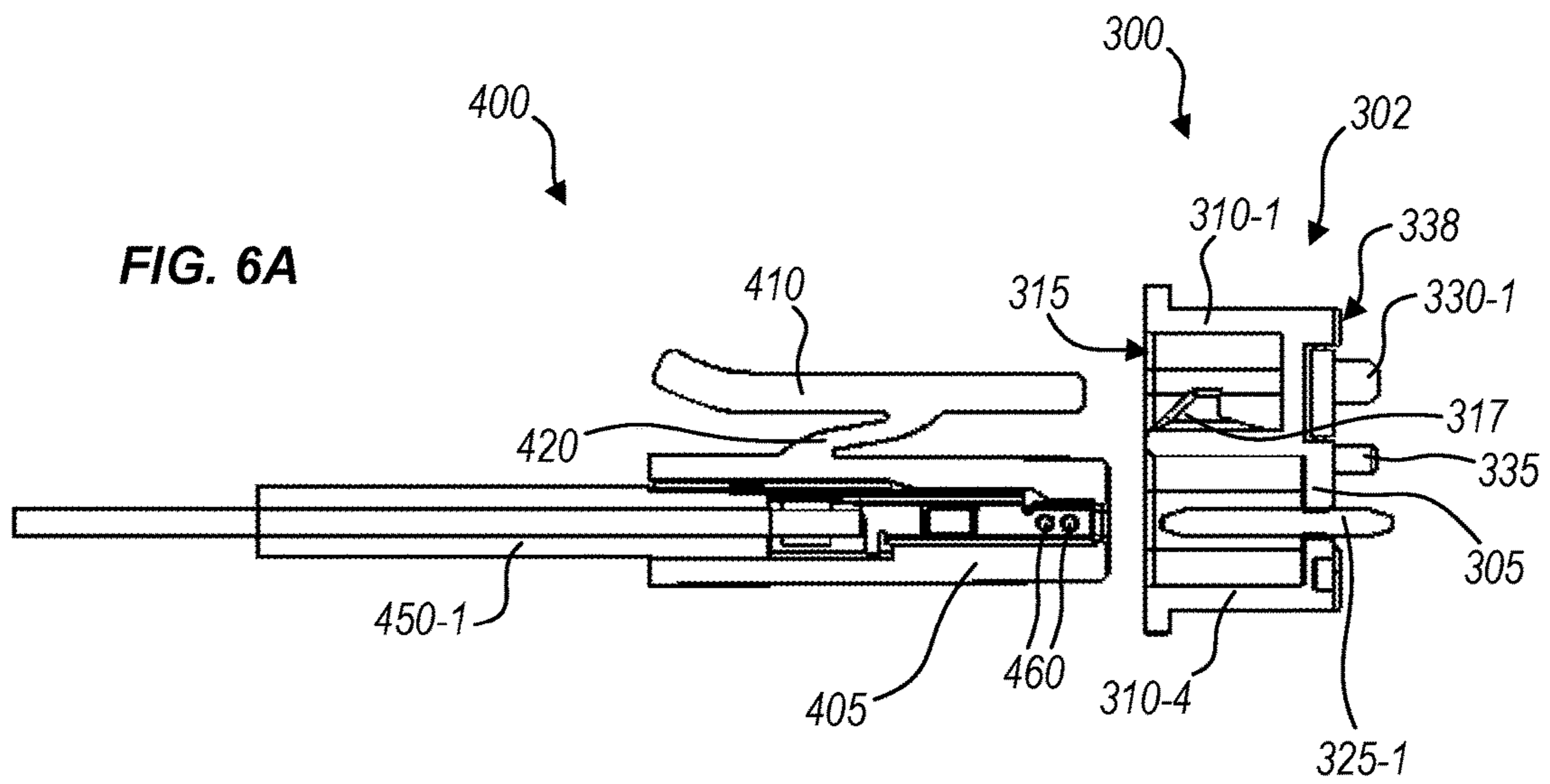

FIG. 3







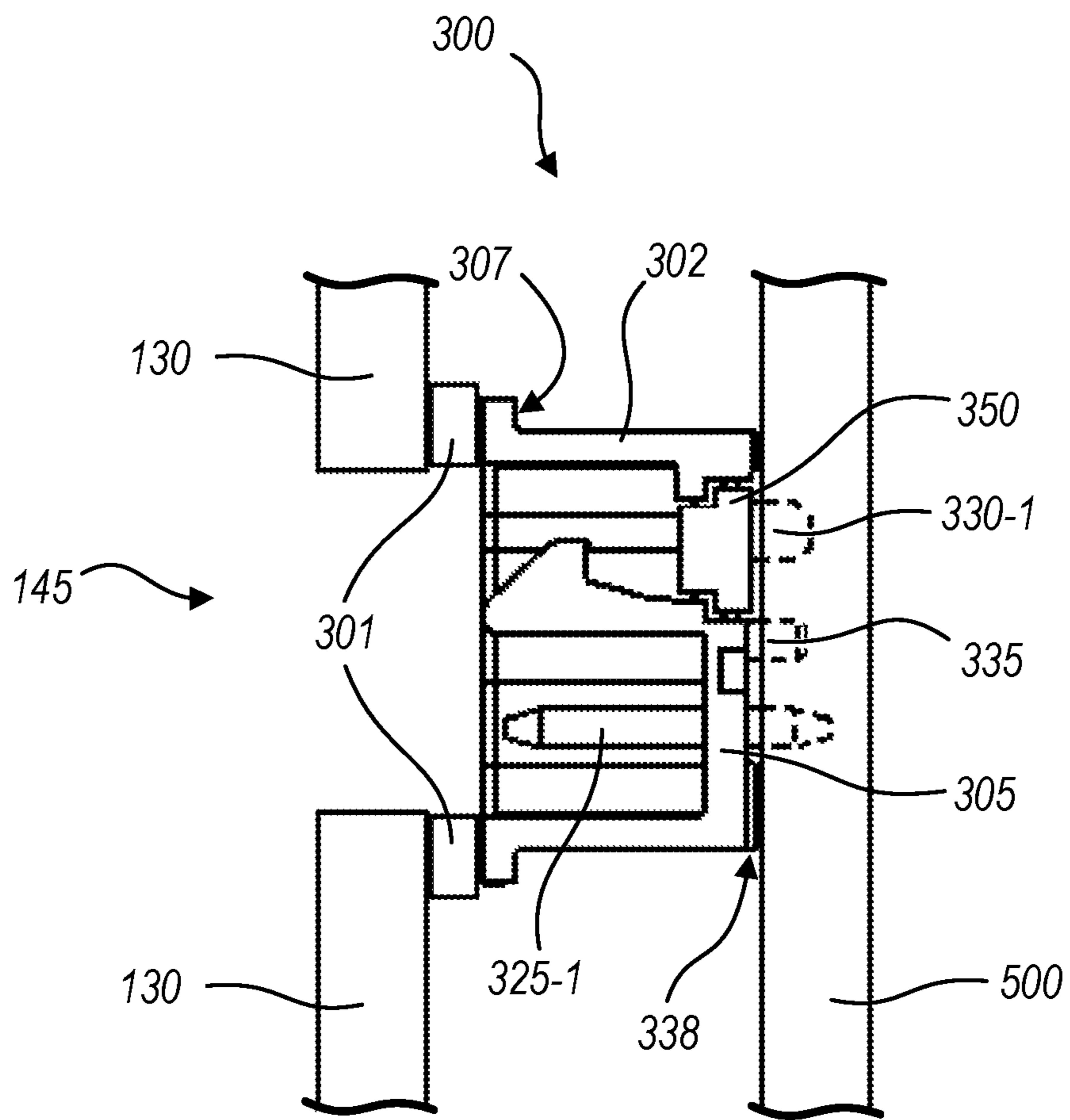

FIG. 7

FIG. 8A

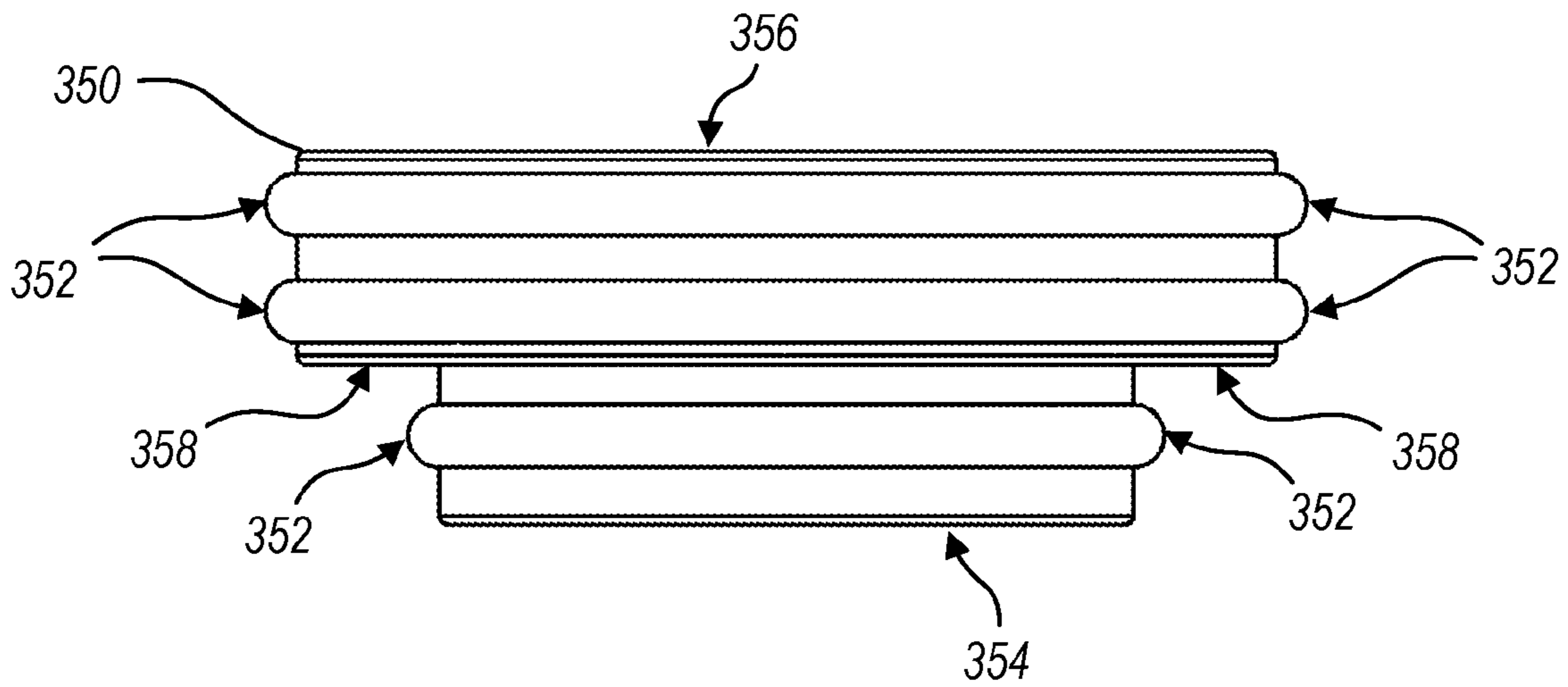
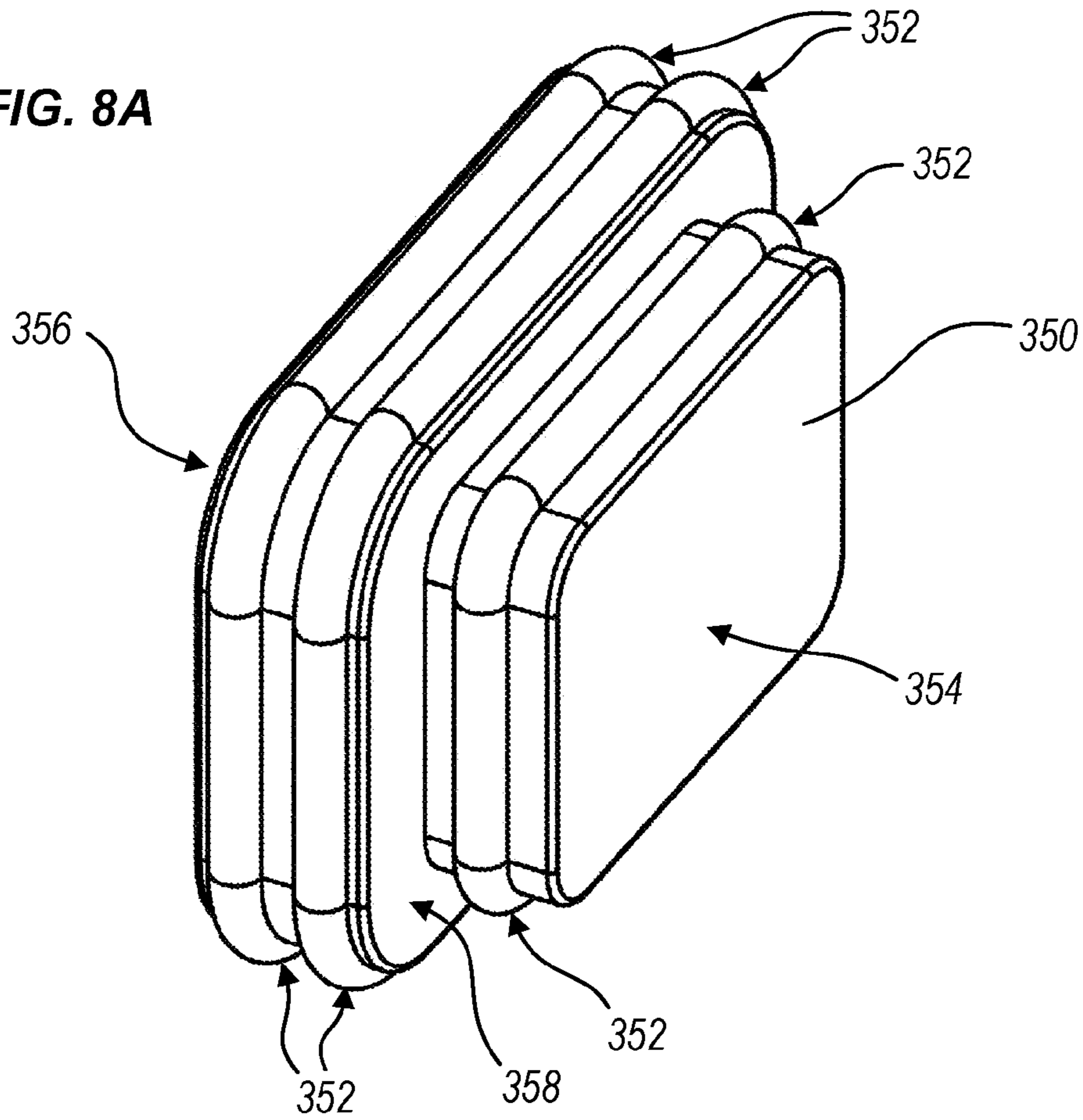

FIG. 8B

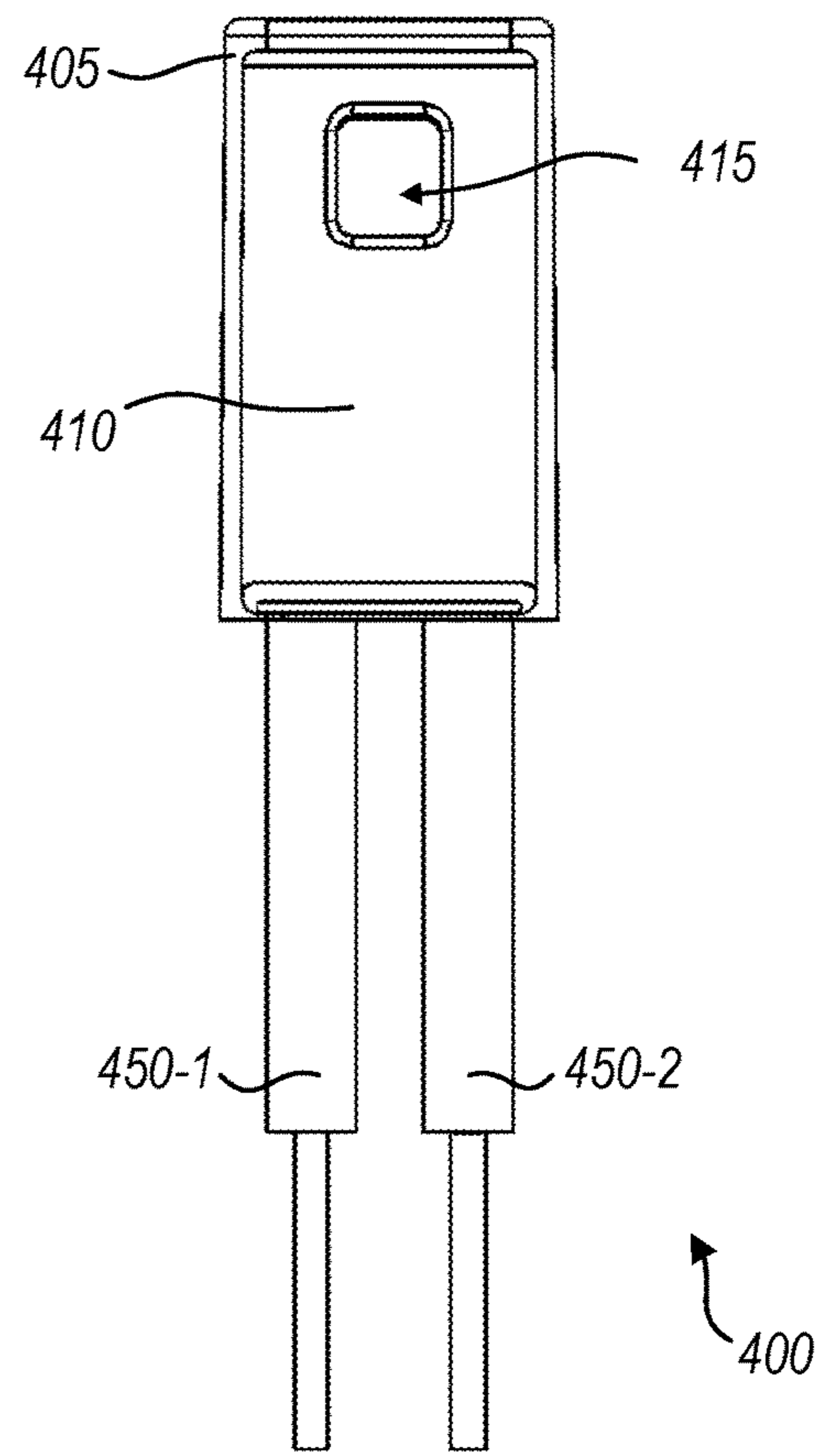
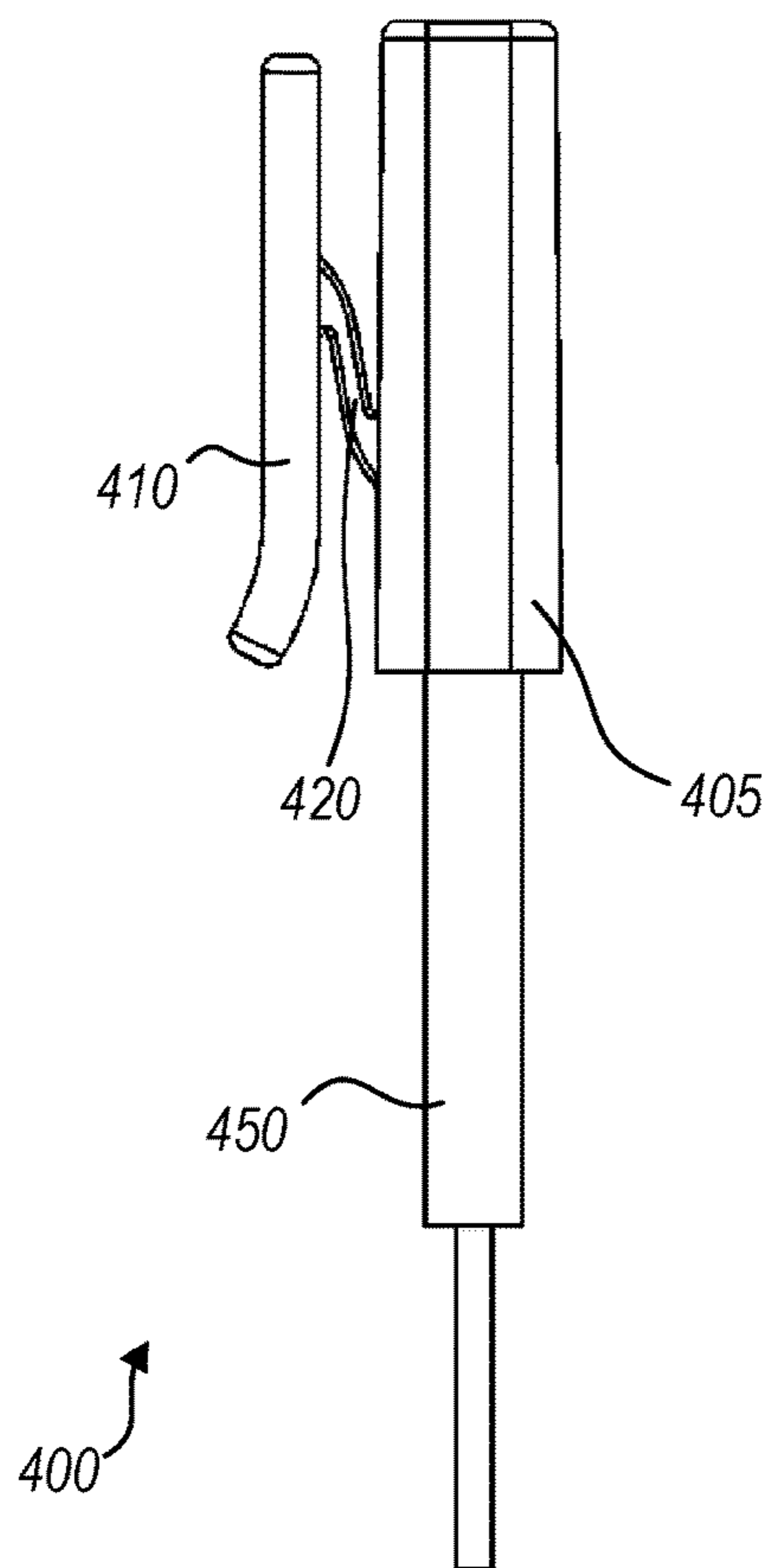
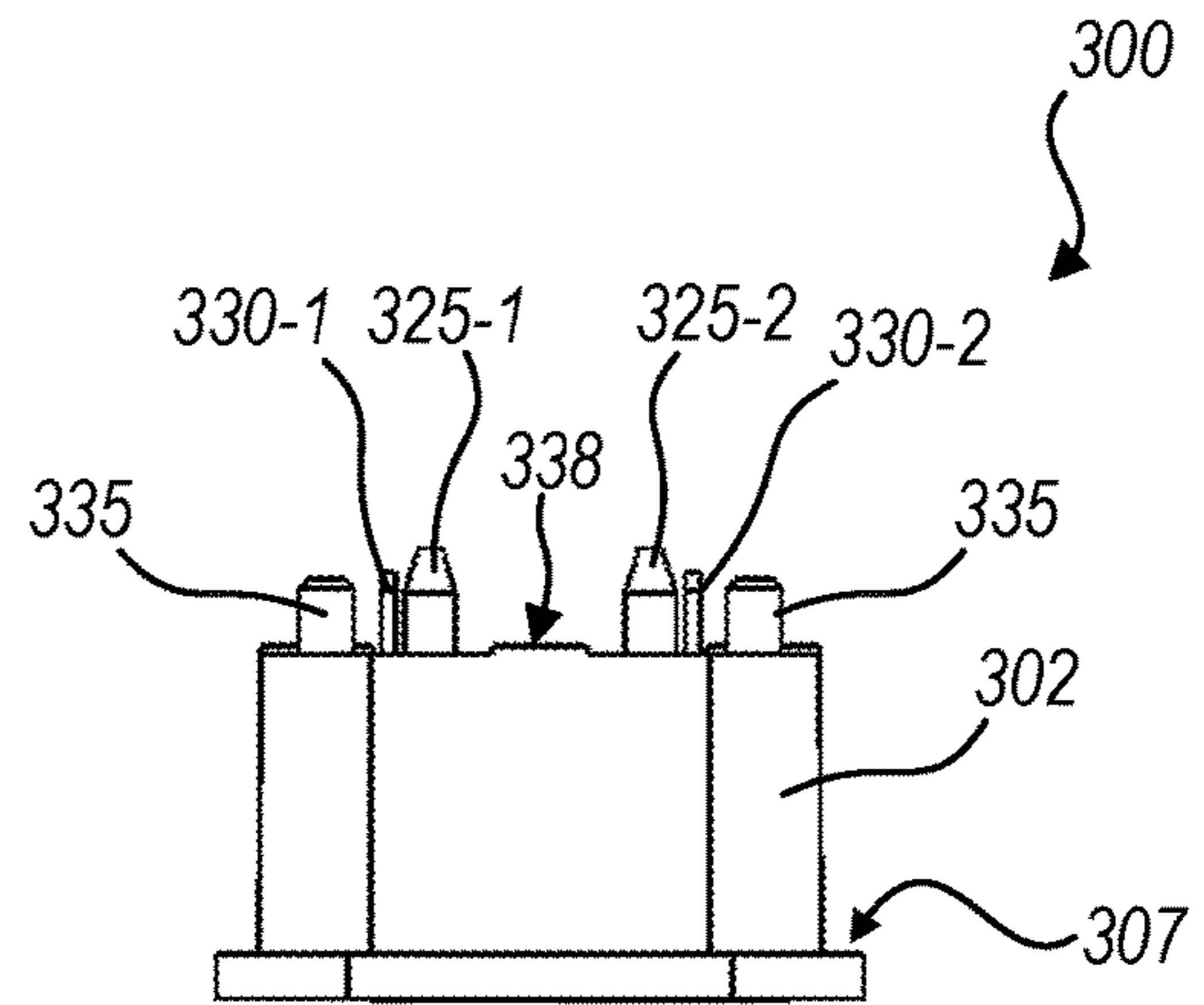
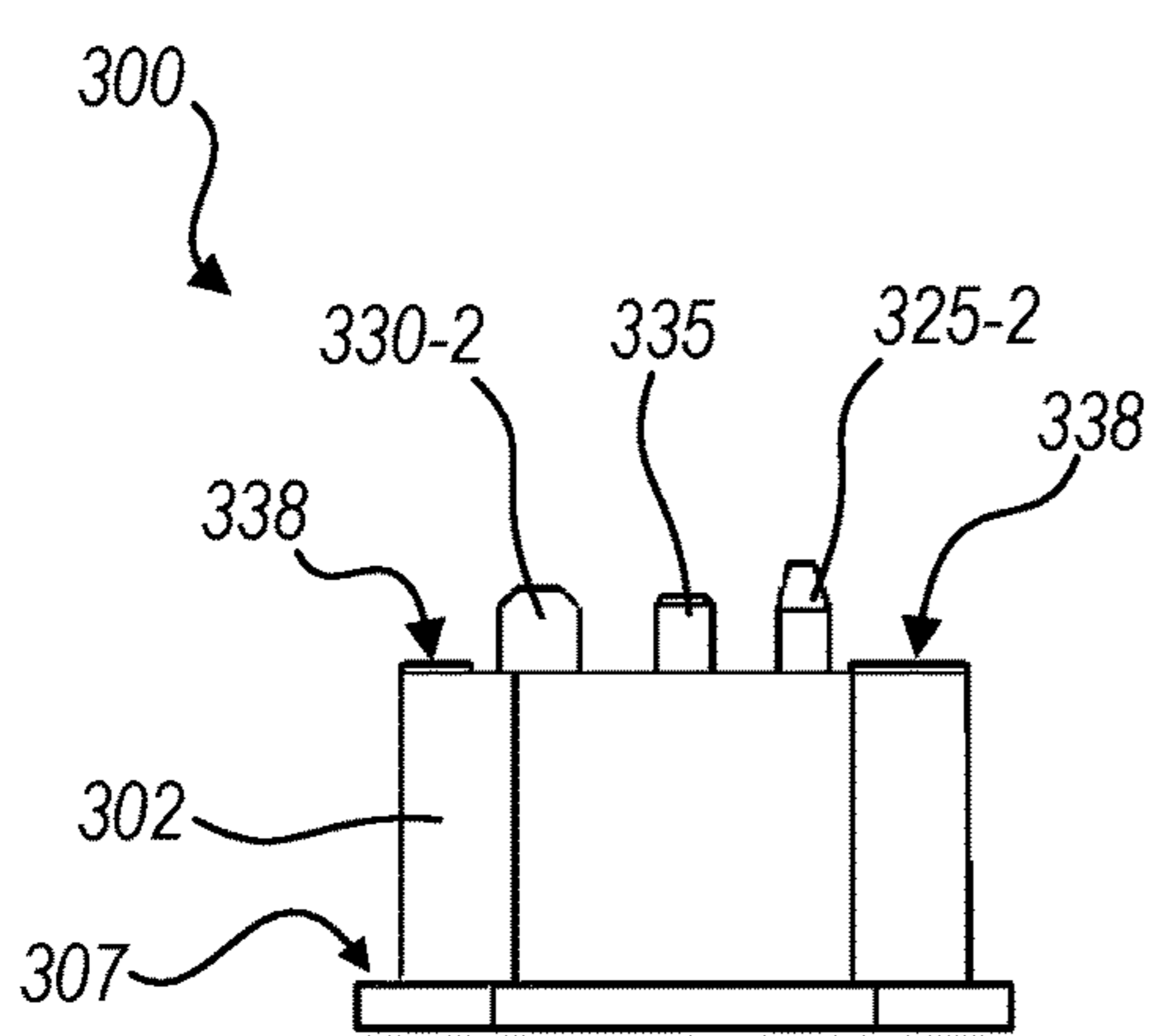

FIG. 9A

FIG. 9B

1

ELECTRICAL CONNECTOR FOR ATMOSPHERIC ISOLATION

CROSS-REFERENCES TO RELATED APPLICATIONS

This application is a continuation of U.S. patent application Ser. No. 14/713,589, filed May 15, 2015, entitled “HAZARD DETECTOR ELECTRICAL CONNECTOR FOR EASY USER MANIPULATION AND ATMOSPHERIC ISOLATION”, the entire disclosure of which is hereby incorporated by reference for all purposes.

BACKGROUND

In some forms of hazard detectors, such as optical smoke detectors, a smoke chamber is used for creating a controlled environment in which electromagnetic radiation is emitted and sensed. While it may be desired to maximize airflow between the interior of the smoke chamber and an exterior environment, performance of the hazard detector may degrade if a pressure differential exists across the hazard detector. That is, if the hazard detector is mounted in a location that provides higher pressure on one side (e.g., a side that is not necessarily to be monitored) it may be possible for air in the higher pressure area to push away the air that is to be monitored.

SUMMARY

In an embodiment, an electrical connector for a hazard detector includes a socket body that includes four lateral walls, a rear wall, a catch feature and a catch support. Each of the four lateral walls adjoins two others of the lateral walls, and the rear wall, continuously and airtightly along edges thereof. The catch support continuously adjoins two of the lateral walls along edges of the catch support to asymmetrically define a catch cavity and a plug cavity on opposing sides of the catch support, a first side of the rear wall facing the plug cavity and a second, counterfacing side of the rear wall bounding a rear surface of the socket body. The catch feature couples with the catch support within the catch cavity. A plurality of electrical pins passes through the rear wall of the socket body such that one end of each of the electrical pins is disposed within the plug cavity, and an opposing end of each of the electrical pins extends away from the rear surface of the socket body.

In an embodiment, a hazard detector includes an enclosure that defines an aperture, and a socket that receives electrical power for operating the hazard detector. The socket includes a socket body having four lateral walls and a rear wall, each of the four lateral walls adjoining two others of the lateral walls, and the rear wall, continuously and airtightly along edges thereof, forming a plug cavity. The socket body forms a mounting flange along edges of the lateral walls that are furthest from the rear wall. The socket further includes a plurality of electrical pins that pass through the rear wall of the socket body, such that first ends of each of the electrical pins are disposed within the plug cavity, and opposing ends of each of the electrical pins extend away from a rear surface of the socket body. The socket is coupled with the enclosure such that the mounting flange forms an airtight seal with the enclosure about a periphery of the aperture.

BRIEF DESCRIPTION OF THE DRAWINGS

A further understanding of the nature and advantages of various embodiments may be realized by reference to the

2

following figures. In the appended figures, similar components or features may have the same reference label. Further, various specific components may be distinguished by a reference label followed by a dash and a second label that distinguishes among the similar components (e.g., electrical pins **325-1**, **325-2**). If only the first reference label is used in the specification (e.g., electrical pins **325**), the description is applicable to any one of the similar components having the same first reference label irrespective of the second reference label.

FIGS. **1A** and **1B** illustrate an embodiment of a smart combined smoke detector and carbon monoxide device.

FIGS. **2A**, **2B**, **2C** and **2D** illustrate an embodiment of an exploded smart combined smoke detector and carbon monoxide hazard detector.

FIG. **3** shows an exploded isometric view of certain components of the hazard detectors of FIGS. **1A**, **1B**, **2A**, **2B**, **2C** and/or **2D**, including a connector socket and a connector plug, in accord with an embodiment.

FIGS. **4A** and **4B** show front and rear elevations, respectively, of the connector socket of FIG. **3**, in accord with an embodiment.

FIGS. **5A** and **5B** show cutaway views of the connector socket and connector plug of FIG. **3** taken along line **5-5'**, FIGS. **4A** and **4B**, in accord with an embodiment.

FIGS. **6A** and **6B** show cutaway views of the connector socket and connector plug of FIG. **3** taken along line **6-6'**, FIGS. **4A** and **4B**, in accord with an embodiment.

FIG. **7** is a cutaway illustration of the connector socket of FIG. **3** mounted within a hazard detector, in accord with an embodiment.

FIGS. **8A** and **8B** are isometric and top plan views respectively of a sealing plug, showing a plurality of sealing features that engage surfaces of a molding aperture to form an airtight seal of the connector socket of FIG. **3**, in accord with an embodiment.

FIGS. **9A** and **9B** are a side elevation and a top plan view, respectively, of the connector socket and the connector plug of FIG. **3**, in accord with an embodiment.

DETAILED DESCRIPTION

Aesthetics and ease of operation—which may be collectively thought of as contributing to “user experience”—drive consumer acceptance and marketability of many devices that may be installed in homes. Hazard detectors, such as for example smoke or carbon monoxide alarms, are no exceptions to this. Not all present day hazard detectors maintain a good user experience while meeting the utilitarian (e.g., safety driven) specifications demanded of them. The present disclosure provides embodiments of electrical connectors for use in hazard detectors, that meet such specifications while providing a high level of user experience. It is to be appreciated that, as used herein, the term user(s) may refer, without limitation, to one or more of customer(s), installer(s), homeowner(s), occupant(s), guest(s), tenant(s), landlord(s), repair person(s), according to the context of the interaction described.

For overall understanding, a big picture view of an embodiment of a hazard detector is first described. Such a device may be a dedicated smoke detector or a combination device, such as a combined carbon monoxide and smoke detector. FIG. **1** illustrates an embodiment of a hazard detector **100**, in the form of a smart combined smoke and carbon monoxide detector. Hazard detector **100** may be suitable for mounting to a wall or ceiling in a room (or other location) within a structure in which smoke and/or carbon

monoxide is to be monitored. Hazard detector **100** may be a “smart device,” meaning hazard detector **100** can communicate, likely wirelessly, with one or more other devices or networks. For instance, hazard detector **100** may communicate with a remote server via the Internet through any of a variety of different communication schemes including, but not limited to, a combination of a home network and Internet Service Provider (ISP), a wired or wireless telephone network, a 3G/4G or greater wireless data communications network, and so forth. The hazard detector **100** may further communicate with any of a variety of other smart-home devices using any of a variety of communications including, but not limited to, a home wireless network, such as an IEEE 802.11a/b/g network, a standard or proprietary low-power mesh communications network (e.g., 802.15.4-based networks, Zigbee®, Z-Wave®, Thread™, etc.), home wired networks (e.g., CATS/6 Ethernet), home powerline networks (e.g., Homeplug), and so forth, including any of a variety of hybrid combinations thereof. A smart device may allow a user to interact with the device via wireless communication, either via a direct or network connection between a computerized device (e.g., smart watch, cellular phone, tablet computer, laptop computer, desktop computer, etc.) and the smart device. One particularly advantageous context includes embodiments in which the hazard detector **100** achieves data communications via a home powerline connection, with increased data capacity being fostered by a dependable, clean, reliable AC power connection to hazard detector **100**.

FIG. 1A illustrates an angular top projection view of hazard detector **100**. Hazard detector **100** may generally be square or rectangular and have rounded corners. Visible in the angular top projection view are various components of hazard detector **100**, including: an aesthetically pleasing cover grille **110**, lens/button **120**, and enclosure **130**. Cover grille **110** may serve to allow air to enter hazard detector **100** through many holes, giving hazard detector **100** an aesthetically pleasing appearance. Cover grille **110** may further serve to allow light to pass into the external environment of hazard detector **100** from internal light sources (e.g., indicator LEDs). Light may be routed internally to cover grille **110** by a light pipe (**230**, noted in relation to FIG. 2A). It should be understood that the arrangement of holes and shape of cover grille **110** may vary by embodiment. Lens/button **120** may serve multiple purposes. First, lens/button **120** may function as a lens, such as a Fresnel lens, for use by a sensor, such as an infrared (IR) sensor, located within hazard detector **100** behind lens/button **120** for viewing the external environment of hazard detector **100**. Additionally, lens/button **120** may be actuated by a user by pushing lens/button **120**. Such actuation may serve as user input to hazard detector **100**. Enclosure **130** may serve as a housing for at least some of the components of hazard detector **100**.

FIG. 1B illustrates an angular bottom projection view of hazard detector **100**. Visible in FIG. 1B is a portion of enclosure **130**. A battery compartment door **140** is present through which a battery compartment is accessible. Also visible are air flow vents **150-1** and **150-2**, which allow air to pass through enclosure **130** and enter a smoke chamber of hazard detector **100**, and an aperture **145**, for a connector to be described in detail below.

FIGS. 2A, 2B, and 2C are exploded views that illustrate an embodiment of a hazard detector **200**, which can be understood as an example of hazard detector **100** of FIGS. 1A and 1B. In FIG. 2A, hazard detector **200** is shown having cover grille **110** and enclosure **130**, which together house main chassis **210**. Main chassis **210** may house various

components that can be present in various embodiments of hazard detector **200**, including speaker **220**, light pipe **230** and microphone **240**. In FIG. 2B, cover grille **110**, enclosure **130**, air flow vent **150-3** and battery compartment door **140** are visible. Additionally visible is a shield **250** between an underlying printed circuit board (PCB) and enclosure **130**. Protruding through shield **250** is smoke chamber **260**. A gap may be present between enclosure **130** and shield **250** to allow airflow through air flow vents **150** to have a relatively unobstructed path to enter and exit smoke chamber **260**. FIG. 2B also illustrates multiple batteries, installed within a battery compartment **270** of hazard detector **200** and accessible via battery compartment door **140**.

FIG. 2C is a more comprehensive exploded view of hazard detector **200**. Illustrated in FIG. 2C are cover grille **110**, cosmetic mesh **280**, lens/button **120**, light pipe **281**, button flexure **283**, chassis **210**, gasket **284**, passive infrared (PIR) and light emitting diode (LED) daughterboard **285**, speaker **220**, batteries **271**, carbon monoxide (CO) sensor **286**, alarm buzzer **287**, main circuit board **288**, external socket **300** (discussed below), smoke chamber **260**, chamber shield **289**, enclosure **130** and surface mount plate **290**.

Cosmetic mesh **280** sits behind cover grille **110** to obscure external visibility of the underlying components of hazard detector **200**, while allowing for airflow through cosmetic mesh **280**. Light pipe **281** serves to direct light generated by lights (e.g., LEDs such as the LEDs present on daughterboard **285**) to the external environment of device **200C** by reflecting off of a portion of cover grille **110**. Button flexure **283** serves to allow a near-constant pressure to be placed by a user on various locations on lens/button **120** to cause actuation. Button flexure **283** may cause an actuation sensor located off-center from lens/button **120** to actuate in response to user-induced pressure on lens/button **120**. Daughterboard **285** may have multiple lights (e.g., LEDs) and a PIR sensor (or other form of sensor). Daughterboard **285** may be in communication with components located on main circuit board **288**. The PIR or other form of sensor on daughterboard **285** may sense the external environment of hazard detector **200** through lens/button **120**. Gasket **284** may at least partially house microphone **240** (FIG. 2B) and help to isolate the PIR sensor on daughterboard **285** from dust, bugs and the like that may affect performance of hazard detector **200**.

Alarm buzzer **287**, which may be activated to make noise in case of an emergency (and when testing emergency functionality), and carbon monoxide sensor **286** may be located on main circuit board **288**. Main circuit board **288** may interface with one or more batteries **271**, which serve as either a primary source of power for the device, or as a backup source of power if another source, such as power received via socket **300**, is unavailable. Protruding through main circuit board and shield **250** (FIG. 2B) may be smoke chamber **260**, such that air (including smoke, if present in the external environment) passing between shield **250** and enclosure **130** is likely to enter smoke chamber **260**. Smoke chamber **260** may be capped by chamber shield **289**, which may be conductive (e.g., metallic). Smoke chamber **260** may be encircled by a conductive (e.g., metallic) mesh (not pictured). Enclosure **130** may be attached and detached from surface mount plate **290**. Surface mount plate **290** may be configured to be attached via one or more attachment mechanisms (e.g., screws or nails) to a surface, such as a wall or ceiling, to remain in a fixed position. Enclosure **130** may be attached to surface mount plate **290** and rotated to a desired orientation (e.g., for aesthetic reasons). For instance enclosure **130** may be rotated such that a side of enclosure

5

130 is parallel to an edge of where a wall meets the ceiling in the room in which hazard detector 200 is installed.

FIG. 2D is an exploded view of hazard detector 200 viewed from a reverse angle as compared with the view of FIG. 2C. Shown in the FIG. 2D view of hazard detector 200 are cover grille 110, cosmetic mesh 280, lens/button 120, light pipe 281, button flexure 283, main chassis 210, gasket 284, passive infrared (PIR) and light emitting diode (LED) daughterboard 285, batteries 271, speaker 220, main circuit board 288, socket 300, smoke chamber 260, chamber shield 289, enclosure 130, and surface mount plate 290. It should be understood that alternate embodiments of hazard detector 200 may include more, fewer or different components than illustrated in FIGS. 2A, 2B, 2C and/or 2D.

An external power connector for hazard detector 100 or 200, that is configured for easy user manipulation and atmospheric isolation, is now described. FIGS. 3, 4A, 4B, 5A, 5B, 6A and 6B illustrate features of an embodiment of the connector socket, its mating plug and its emplacement in a hazard detector. These features are listed first, followed by a discussion of innovative features of the connector socket and plug, and their integration within a hazard detector. It should be understood that although the connector described below is designed as an alternating-current (AC) connector, the construction and operational principles would apply equally to a connector for direct-current (DC) external power.

FIG. 3 shows an exploded isometric view of certain components of hazard detector 100 or 200. Illustrated within FIG. 3 are an interior surface of enclosure 130, along with a connector socket 300 and a connector plug 400 that supply power to the hazard detector. Features of connector socket 300 that are labeled in FIG. 3 include a socket body 302 that includes a mounting flange 307, a top wall 310-1 and a side wall 310-2. Top wall 310-1, side wall 310-2, and a further side wall 310-3 and bottom wall 310-4 (see FIG. 4B) are also collectively referred to as lateral walls 310 herein. FIG. 3 also shows that top wall 310-1 transitions into side wall 310-2 along a curved profile and that mounting flange 307 features rounded corners. When assembled, socket body 302 presses against an optional gasket 301 located between mounting flange 307 and the interior surface of enclosure 130, with plug and catch cavities (discussed below) of socket body 302 facing aperture 145. Gasket 301 may not be present in all cases, e.g., mounting flange 307 and the internal surface of enclosure 130 may be manufactured to tolerances that provide an airtight fit without gasket 301, may include interlocking features that provide the airtight fit, and/or mounting flange 307 may be press-fit into aperture 145. Features of connector plug 400 that are visible in FIG. 3 include plug body 405, latch member 410 defining latch aperture 415, pin sockets 425, and wires 450-1, 450-2.

FIGS. 4A and 4B show front and rear elevations, respectively, of connector socket 300. FIG. 4A shows mounting flange 307, positions of interior surfaces of top wall 310-1, side walls 310-2 and 310-3 and bottom wall 310-4, a catch cavity 315 and a plug cavity 320 defined by lateral walls 310 and a catch support 318 between the cavities, a catch feature 317 coupled with catch support 318, electrical pins 325-1, 325-2, interior surfaces of stabilizing prongs 330-1, 330-2 and molding aperture 345 within rear wall 305. Like FIG. 3, FIG. 4A shows that all four lateral walls 310 of socket body 302 transition into one another along curved profiles, and that mounting flange 307 features rounded corners. Similarly, catch support 318 transitions into mounting flange 307 and lateral walls 310-2 and 310-3 along rounded profiles. The rounded transitions of lateral walls 310 to one another,

6

and of catch support 318 to lateral walls 310-2 and 310-3 add mechanical strength to socket body 302 for high dimensional stability under physical stress. For this reason, such transitions may have radii of curvature that are greater than or equal to thicknesses of the lateral walls 310. Catch support 318 also asymmetrically divides a cavity formed by the four lateral walls 310, such that plug 400 can only fit into socket 300 in one orientation, as discussed further below. Lateral walls 310, rear wall 305, catch support 318, catch feature 317 and assembly keys 335 are advantageously molded integrally to form socket body 302, although in embodiments socket body 302 may encapsulate metal members as stiffeners. In embodiments, stabilizing prongs 330, electrical pins 325 are formed of phosphor bronze, and are press-fit into socket body 302 after molding. Assembly keys 335 are used, in embodiments, to align socket 300 with a circuit board.

FIG. 4B shows rear wall 305, mounting flange 307, positions of top wall 310-1, lateral walls 310-2 and 310-3 and bottom wall 310-4, electrical pins 325-1, 325-2, stabilizing prongs 330-1, 330-2, assembly keys 335, standoff features 338, molding voids 340 and molding aperture 345 within rear wall 305. Molding aperture 345 penetrates rear wall 305 only in the area shown in FIG. 4A; in the rear view of FIG. 4B, an inner shelf 346 can be seen. Inner shelf 346 assists in maintaining an airtight seal formed by socket 300 by helping a sealing plug (shown in FIGS. 5A, 5B, 6A, 6B) resist moving toward or into catch cavity 315 when positive pressure exists at a rear side of rear wall 305. Standoff features 338 are located about edges of rear wall 305 and extend rearward by a small amount (e.g., about 0.2 mm) from the rest of rear wall 305.

Standoff features 338 create a plane that contacts a PCB that socket 300 couples with (see FIG. 7) to ensure that mounting flange 307 is parallel with the PCB. Also, the height of standoff features 338 is sufficient to allow an appropriately sized solder fillet to form when electrical pins 325-1, 325-2 are soldered to the PCB.

Stabilizing prongs 330 are T-shaped (as seen by comparing FIG. 4A with FIG. 4B) such that a portion of each stabilizing prong 330 that is press-fitted into a front side of rear wall 305 (e.g., inserted through catch cavity 315) is wider than a portion that protrudes from rear wall 305. Also, it should be noted that for mechanical strength, stabilizing prongs 330 are fitted into the thicker portion of rear wall 305 discussed above. A first end (e.g., the crossbar of the T) of each stabilizing prong is approximately coplanar with a front surface of rear wall 305, and a second end of each stabilizing prong protrudes from rear wall 305. Once the portions of stabilizing prongs 330 that protrude from rear wall 305 are soldered to a PCB, the T shape of stabilizing prongs 330 disposed within the thicker portion of rear wall 305 provides extra ruggedness with respect to lateral forces, such as would be imparted by pulling on wires 450 of plug 400, while plug 400 is latched into socket 300. That is, instead of such lateral forces being undesirably transmitted solely to electrical pins 325, such forces are largely transmitted to stabilizing prongs 330. Side-to-side lateral forces would be opposed by the two prongs acting together (one would resist the applied tensile stress while the other would resist the applied compressive stress). Up-and-down lateral forces would be opposed by the T-shapes of the prongs compressing against the material of the socket, as well as by acting in concert with the electrical pins. Upon reading and comprehending the present disclosure, one skilled in the art will be able to adapt the principles discussed above to implement similar ways of stabilizing a socket, such as use of a single

stabilizing prong, use of more than two stabilizing prongs, and/or use of stabilizing prongs having more complex shapes.

Like FIG. 3, FIGS. 4A and 4B show that all four walls 310 of socket body 302 transition into one another along curved profiles and that mounting flange 307 features rounded corners; similarly, catch support 318 transitions into mounting flange 307 and lateral walls 310-2 and 310-3 along curved profiles. In both FIGS. 4A and 4B, lines 5-5' and 6-6' indicate cross-sectional planes illustrated in FIGS. 5A and 5B, and FIGS. 6A and 6B, respectively.

FIGS. 5A and 5B are cutaway illustrations of connector socket 300 and connector plug 400 taken along line 5-5' shown in FIGS. 4A and 4B. Both FIGS. 5A and 5B show connector socket 300 with socket body 302, including rear wall 305, mounting flange 307, top wall 310-1, bottom wall 310-4, catch feature 317 and standoff feature 338. A sealing plug 350 is seated against shelf 346 within a molding aperture 345 defined in rear wall 305 (see FIGS. 4A, 4B and FIG. 8). As shown in FIGS. 5A and 5B, rear wall 305 is thicker where it is adjacent to catch cavity 315 than where it is adjacent to plug cavity 320. The increased thickness of rear wall 305 adjacent to catch cavity 315 provides improved ruggedness for transmitting mechanical loads to stabilizing prongs 330, as discussed below, enables formation of shelf 346 (FIG. 4B) for sealing plug 350 to seat against, and increases the cross-sectional area available for sealing surfaces of plug 350 to seal against, to maintain airtightness.

Both FIGS. 5A and 5B also show connector plug 400 with plug body 405, latch member 410, latch aperture 415 defined within latch member 410, and latch spring 420. Plug body 405 is advantageously molded integrally with latch spring 420 and latch member 410. In embodiments, plug 400 may encapsulate metal members as stiffeners. It can be seen in FIGS. 5A and 5B that plug body 405 is sized to fit within plug cavity 320, but not within catch cavity 315, such that plug 400 cannot be inserted into socket 300 upside down. (Similarly, once socket 300 is mounted within hazard detector 100, 200, plug body 405 also cannot be inserted upside down into plug cavity 320, because latch member 410 will run up against enclosure 130; see FIG. 3). FIG. 5A shows connector plug 400 positioned for insertion into connector socket 300, while FIG. 5B shows connector plug 400 inserted into connector socket 300, with latch member 410 engaged with catch feature 317. Latch aperture 415 is sized to accommodate catch feature 317; that is, when latch member 410 engages with catch feature 317, latch aperture 415 fits about catch feature 317 but does not permit significant movement of latch member 410 (and thus plug 400) with respect to socket 300 in the direction of insertion and withdrawal.

FIGS. 6A and 6B are cutaway illustrations of connector socket 300 and connector plug 400 taken along line 6-6', FIGS. 4A and 4B. Both FIGS. 6A and 6B show connector socket 300 with socket body 302 including rear wall 305, mounting flange 307, top wall 310-1, bottom wall 310-4 and standoff feature 338. Sealing plug 350 is seated within molding aperture 345 defined in rear wall 305 (see FIGS. 4A, 4B); molding aperture 345 does not completely penetrate rear wall 305 in the cross-sectional plane of FIGS. 6A and 6B (see FIG. 4B). Electrical pin 325-1 extends through rear wall 305. As shown in FIGS. 6A and 6B, rear wall 305 is thicker where it is adjacent to catch cavity 315 than where it is adjacent to plug cavity 320, for improved dimensional stability. Both FIGS. 6A and 6B also show connector plug 400 with plug body 405, latch member 410, pin socket 425-1

and wire 450-1. FIG. 6A shows contact features 460 that scrub against electrical pins when plug 400 is inserted into socket 300; contact features 460 are hidden behind electrical pin 325-1 in the view of FIG. 6B. FIG. 6A shows connector plug 400 positioned for insertion into connector socket 300, while FIG. 6B shows connector plug 400 inserted into connector socket 300, with electrical pin 325-1 engaged with pin socket 425-1.

Socket 300 and plug 400 are jointly optimized to provide easy user manipulation and tactile feedback for a high level of user experience, while meeting a variety of electrical and mechanical specifications. Exemplary requirements that are jointly met or exceeded by embodiments such as socket 300 and plug 400 are provided in the following table. Some of the listed requirements are based specifications such as Underwriters' Laboratories (UL) 217 sections 17.4, 41, 71, UL 268 section 11.4, UL 521 section 48, UL 2034 section 67.3, Appliance Wiring Materials (AWM) 3386 and Electronics Industry Alliance (EIA) 364, and others are based on requirements to provide good user experience.

TABLE 1

Specifications for hazard detector connector/plug system		
Item	Requirement	Basis for requirement
Electrical voltage rating	300 V AC	Max 240 VAC (EU)
Insulation Resistance	1000 MOhms min after 1 minute at 500 VDC	EIA 364
Dielectric Withstanding Voltage	500 VAC for 1 minute at sea level	EIA 364
Maximum socket temperature	>260 C.	Survive heat of soldering or reflow
Insertion force	<15 N	User experience
Feedback upon engaging plug with socket	Tactile and audible "click"	User experience
Retention force	>44.5 N	UL 217, UL 568
Electrical connection stability	<10 mOhm change in resistance with 50 N side-load applied to wire harness (mated pair)	EIA 364
Disassembly forces	Can be applied to plug only for one hand operation	User experience
Withdrawal force, unlatched	<15 N	User experience
Atmospheric isolation	<1% change in per-foot obscuration within hazard detector sensitivity with 0.015 in H2O back-pressure	UL 217 section 41

In some cases, prior art connectors for hazard detectors meet the retention force and atmospheric isolation requirements of Table 1 by providing a plug that would fit tightly within a corresponding socket, and would not necessarily latch into place. In some such cases, sockets were sometimes constructed as frames, instead of closed-end boxes, so the sockets would not necessarily be airtight. However, the plug would be airtight, and would form a seal to the socket about its periphery to complete a largely airtight seal of the socket. Such arrangements did not always provide a good user experience, as they involved high insertion forces to achieve the tight fit, and did not necessarily provide tactile or audible feedback when the plug was fully seated. Further, such connectors did not necessarily meet the dimensional stability requirement of Table 1, because pulling on the plug and/or wires could cause the socket frame to distort. Still further, the ability of such connectors to meet the retention force specification is not always guaranteed, as the force with

which the plug is put into the socket by the user—which can vary, depending on the user and other circumstances—may determine the retention force. And, the withdrawal force would be quite high, as it would have to exceed the retention force. In other cases, a plug would simply couple with pins on a circuit board, with foam filling gaps between the plug and the area around the pins to provide a seal; often such arrangements would require coupling two latches against an opposing force of the foam, to maintain the seal by ensuring immobility of the plug. Arrangements of this type tend to provide poor user experience by requiring careful user alignment of the plug with the pins and requiring operation of two latches while holding a plug firmly in place. Also, such arrangements typically resulted in larger physical volume of the connector arrangement, because the latching features of the plug and housing mechanically couple across three or more physical components, each component having its own mechanical tolerances. For example, the plug would include one of the latch or catch features; the plug would mate with pins on a PCB, but the PCB would couple with at least a housing that would include the other of the latch/catch features. Consequently, the volume of the connector arrangement had to be larger than otherwise required, to accommodate the tolerance stackup of the latch and catch features.

Socket 300 and plug 400 meet all of the requirements shown in Table 1 through one or more combinations of the innovative features described above and as follows. In a first example of meeting specifications while providing a good user experience, socket 300 is not provided as a frame, but as socket body 302, including rear wall 305, mounting flange 307, the four walls 310-1 through 310-4, and catch support 318. When sealing plug 350 is seated within molding aperture 345, socket 300 is airtight, and when mounted with an appropriate gasket against aperture 145 of hazard detector 200, forms an airtight plug to seal a back wall of hazard detector 200. Also, as noted in connection with FIGS. 5A and 5B, rear wall 305 is thicker where it is adjacent to catch cavity 315 than where it is adjacent to plug cavity 320. The full “five-sided box” construction of socket body 302 (e.g., rear wall 305 and four lateral walls 310), mounting flange 307, catch support 318, stabilizing prongs 330-1, 330-2, the extra thickness of rear wall 305 adjacent to catch cavity 315 and all of the rounded corners where these features adjoin, render socket 300 mechanically strong so as to meet the dimensional stability requirement of Table 1. The “five-sided box” construction also renders the socket itself airtight, except for the possibility of a molding aperture and a sealing plug, as shown in FIGS. 4A, 4B, 5A, 5B, 6A and 6B, discussed below.

In another example of meeting specifications while providing a good user experience, socket 300 and plug 400 implement a latching system that decouples insertion, retention and withdrawal forces, while also providing tactile and audible feedback as the latch engages. First, the materials utilized to form the major surfaces of socket 300 and plug 400 are made of low friction material. One choice of materials for socket 300 and plug 400 is polyamide 66 nylon, but other plastics may be utilized in embodiments. For example, certain other thermoplastics may also be used, with important criteria including strength, moldability, stability at high temperatures (to withstand heat of soldering) and low friction. With suitable materials, an insertion force required to slide plug 400 into socket 300 is very low until a leading edge of latch member 410 contacts a leading edge of catch feature 317. Further insertion deflects the leading edge of latch member 410 upwards, deforming latch spring

420 and causing an easily felt but not large resistance to further insertion. When plug 400 is inserted such that catch feature 317 is within latch aperture 415, the force built up within latch spring 420 by the deflection snaps latch member 410 back downwards, engaging latch member 410 with catch feature 317 and providing a very definite, tactile and audible “click.”

Once latch member 410 is engaged, plug 400 exhibits a very high retention force within socket 300 (e.g., removal of plug 400 without disengaging latch member 410 would require a force high enough to destroy latch member 410, latch spring 420, catch feature 317 and/or catch support 318). As illustrated, plug 400 and socket 300 significantly exceed the 44.5 N minimum retention force specified in the applicable UL standards (see Table 1 above).

Socket 300 and plug 400 also advantageously decouple withdrawal force from retention force, and support removal of plug 400 from socket 300 as a one-hand operation. To decouple a plug from its associated socket, certain prior art latching arrangements sometimes require a user to grip or manipulate one feature associated with a device or socket thereof, while simultaneously manipulating a second feature associated with the plug. These and/or other prior art plug and socket arrangements sometimes require a high withdrawal force to remove the plug from the socket, due to a tight physical fit required for an airtight fit. Socket 300 and plug 400 elegantly improve the user experience of decoupling by simply requiring a gentle downward press to decouple latch member 410 from catch feature 317, after which plug 400 has very low withdrawal force, and may be removed by the same hand that provides the downward press.

Socket body 302 is advantageously provided as a one piece, molded part; catch feature 317 provides a challenge in this regard, as a mold for socket body 302 must provide mold features in catch cavity 315 between catch feature 317 and rear wall 305. To provide such mold features, molding aperture 345 is defined in rear wall 305 such that a mold assembly for socket body 302 can include a pin that protrudes through and defines molding aperture 345, and provides the required mold feature for catch feature 317. It may be considered unusual to use this type of mold configuration for a socket body, due to the complexity and expense of the mold arrangement. After socket body 302 is molded, sealing plug 350 is installed so as to seat within molding aperture 345. Sealing plug 350 may be formed of silicone for high temperature performance (e.g., to withstand heat of soldering socket 300), and seats within molding aperture 345 to provide atmospheric isolation for a hazard detector (e.g., hazard detector 100, 200). As installed within a hazard detector, sealing plug 350 is surrounded in the forward and backward directions by shelf 346 (FIG. 4B) and by a PCB to which socket 300 is soldered (FIG. 7) such that sealing plug 350 will not be dislodged from molding aperture 345 even if a significant air pressure imbalance were to exist across socket body 302.

FIG. 7 is a cutaway illustration of connector socket 300 mounted within a hazard detector, e.g., hazard detector 100 or 200. Stabilizing prongs 330 and electrical pins 325 extend into, and are soldered into, holes in a PCB 500. Assembly keys 335 also extend into corresponding holes in PCB 500 to facilitate assembly. In embodiments, one hole in PCB 500 is typically sized to fit a first assembly key 335 very snugly, a second hole is a slot that, when a second assembly key 335 is inserted, constrains rotation of socket 300 with respect to the first assembly key 335. Holes corresponding to stabilizing prongs and electrical pins 325 have looser tolerances for

11

easy assembly, and provide lateral space for solder fillets to be formed subsequently (e.g., using infrared (IR) or other solder reflow techniques).

PCB 500 couples mechanically with enclosure 130, with optional gasket 301 disposed between mounting flange 307 of socket body 302, and enclosure 130. It will be apparent to one skilled in the art that FIGS. 5A, 5B and 7 provide a further illustration of the advantage of the construction of socket body 302 and its cooperation with plug 400. Latch member 410 of plug 400 mates directly with catch feature 317 that is molded into socket body 302, thus, mechanical tolerances of the latch and socket are much smaller than they would be if a latch/catch feature on a plug was required to mate with a corresponding latch/catch feature that is only indirectly coupled to a the plug when installed. In addition to providing a good user experience, the arrangement shown in FIGS. 5A, 5B and 7 enables the plug/connector combination to be smaller than would be possible if plug 400 did not mate directly with socket body 302.

FIGS. 8A and 8B are isometric and top plan views respectively of sealing plug 350, showing a plurality of sealing features 352 that engage surfaces of molding aperture 345 to form an airtight seal of socket 300 (see FIGS. 4A, 4B, 5A, 5B and 7). When assembled with socket 300, rear face 354 faces rearwardly from socket body 302, front face 356 faces forwardly (e.g., into catch cavity 315, see FIGS. 4A, 4B, 5A, 5B and 7) and intermediate face 358 abuts shelf 346 (see FIG. 4B). The geometry of sealing plug 350 is but one example of providing complementary features of molding aperture 345 in rear wall 305 for sealing plug 350 to provide an airtight seal therewith. One skilled in the art will recognize equivalent, complementary features to provide for a molding aperture and a sealing plug to maintain the airtight seal provided by a socket.

FIGS. 9A and 9B are a side elevation and a top plan view, respectively, of socket 300 and plug 400. Features that are described above and are visible in the views of socket 300 include socket body 302 with molded features such as mounting flange 307, standoff features 338 and assembly keys 335, and installed stabilizing prongs 330 and electrical pins 325. Features that are described above and are visible in the views of plug 400 include plug body 405, latch member 410 with latch aperture 415 therein, latch spring 420 and wires 450.

Having described several embodiments, it will be recognized by those of skill in the art that various modifications, alternative constructions, and equivalents may be used without departing from the spirit of the invention. Additionally, a number of well-known processes and elements have not been described in order to avoid unnecessarily obscuring the present invention. Accordingly, the above description should not be taken as limiting the scope of the invention.

What is claimed is:

1. An electrical connector system, the electrical connector system comprising:

a socket, comprising:

a socket body that defines a catch cavity and a plug cavity, wherein the catch cavity and the plug cavity are each formed by a plurality of walls and a wall of the plurality of walls is a shared support wall;

a catch feature that is located within the catch cavity; and

a plurality of electrical pins that pass through a rear wall of the plurality of walls such that one end of each electrical pin of the plurality of electrical pins is disposed within the plug cavity, and an opposing

12

end of each of the plurality of electrical pins extends away from a rear surface of the socket; and

a plug, comprising:

a plug body that forms a plurality of pin sockets;

a plurality of contacts corresponding to the plurality of electrical pins of the socket, each contact of the plurality of contacts being disposed within a respective pin socket of the plurality of pin sockets;

a latch spring attached with the plug body; and

a latch member that removably mechanically couples with the catch feature within the catch cavity such that as the plug body inserts into the plug cavity:

the plurality of electrical pins disposed within the plug cavity insert into the plurality of pin sockets and make contact with the contacts; and
the catch feature deflects the latch member.

2. The electrical connector system of claim 1, wherein the socket is installed on a sensor device that is part of the electrical connector system such that when the plug is inserted into the socket, a battery compartment door of the sensor device cannot fully open.

3. The electrical connector system of claim 2, wherein the sensor device is a hazard detector that detects smoke, carbon monoxide, or both.

4. The electrical connector system of claim 1, wherein the plurality of walls of the socket body continuously and airtightly adjoin to form the catch cavity and the plug cavity.

5. The electrical connector system of claim 1, wherein the catch feature is attached to the shared support wall within the catch cavity.

6. The electrical connector system of claim 1, wherein the latch spring is made of nylon and exerts force when deformed by the catch feature pressing against the latch member.

7. The electrical connector system of claim 6, wherein an insertion force of the plug into the socket body is less than 15 N.

8. The electrical connector system of claim 1, wherein the socket further comprises one or more stabilizing prongs that are press-fit into corresponding apertures within the socket body, such that a first end of each stabilizing prong is approximately coplanar with a front surface of the rear wall of the plurality of walls and a second end of each stabilizing prong protrudes from the rear wall.

9. The electrical connector system of claim 1, wherein the plurality of electrical pins, the plurality of pin sockets, and the plurality of contacts comprise exactly two electrical pins, exactly two pin sockets, and exactly two contacts, respectively.

10. The electrical connector system of claim 1, further comprising a gasket that contacts at least four walls of the plurality of walls of the socket and airtightly seals the socket against an enclosure of a sensor device.

11. An electrical connector, the electrical connector comprising:

a socket, comprising:

a socket body that defines a catch cavity and a plug cavity, wherein the catch cavity and the plug cavity are each formed by a plurality of walls and a wall of the plurality of walls is a shared support wall;

a catch feature that is located within the catch cavity; and

a plurality of electrical pins that pass through a rear wall of the plurality of walls such that one end of each electrical pin of the plurality of electrical pins is disposed within the plug cavity, and an opposing

end of each of the electrical pins extends away from a rear surface of the socket.

12. The electrical connector of claim 11, wherein the socket of the electrical connector is positioned on a sensor device such that when a plug is inserted into the socket, a battery compartment door of the sensor device cannot fully open.

13. The electrical connector of claim 12, wherein the sensor device is a hazard detector that detects smoke, carbon monoxide, or both.

14. The electrical connector of claim 11, wherein the catch feature is attached with the shared support wall within the catch cavity.

15. The electrical connector of claim 11, wherein the plurality of walls of the socket body continuously and airtightly adjoin to form the catch cavity and the plug cavity.

16. The electrical connector of claim 15, further comprising a gasket that contacts at least four walls of the plurality of walls of the socket and airtightly seals the socket against an enclosure of a sensor device.

* * * * *