



US009925335B2

(12) **United States Patent**  
**Constantineau et al.**

(10) **Patent No.:** **US 9,925,335 B2**  
(45) **Date of Patent:** **Mar. 27, 2018**

(54) **PORTABLE DRUG MIXING AND DELIVERY DEVICE AND ASSOCIATED METHODS**

(71) Applicant: **WINDGAP MEDICAL, INC.**,  
Somerville, MA (US)

(72) Inventors: **Cole Constantineau**, Cambridge, MA (US); **Christopher J. Stepanian**, Somerville, MA (US); **Adam R. Standley**, Cambridge, MA (US); **Michel Bruehwiler**, Newton, MA (US); **Brent Buchine**, Austin, TX (US); **Jeffrey Thomas Chagnon**, Somerville, MA (US); **Robert Brik**, Cambridge, MA (US)

(\* ) Notice: Subject to any disclaimer, the term of this patent is extended or adjusted under 35 U.S.C. 154(b) by 82 days.

(21) Appl. No.: **15/035,132**

(22) PCT Filed: **Aug. 18, 2015**

(86) PCT No.: **PCT/US2015/045768**

§ 371 (c)(1),  
(2) Date: **Aug. 1, 2016**

(87) PCT Pub. No.: **WO2016/028820**

PCT Pub. Date: **Feb. 25, 2016**

(65) **Prior Publication Data**  
US 2016/0263320 A1 Sep. 15, 2016

**Related U.S. Application Data**

(60) Provisional application No. 62/038,386, filed on Aug. 18, 2014, provisional application No. 62/126,011, (Continued)

(51) **Int. Cl.**  
**A61M 5/19** (2006.01)  
**A61M 39/22** (2006.01)  
(Continued)

(52) **U.S. Cl.**  
CPC ..... **A61M 5/19** (2013.01); **A61M 5/2033** (2013.01); **A61M 5/2046** (2013.01);  
(Continued)

(58) **Field of Classification Search**  
CPC ..... **A61J 1/1406**; **A61J 1/201**; **A61M 39/22**; **A61M 5/19**; **A61M 5/2033**; **A61M 5/2046**; **A61M 5/31596**; **A61M 5/3204**  
See application file for complete search history.

(56) **References Cited**  
**U.S. PATENT DOCUMENTS**

3,680,558 A 8/1972 Kapelowitz  
3,946,732 A 3/1976 Hurscham  
(Continued)

**FOREIGN PATENT DOCUMENTS**

EP 961612 B1 4/2009  
FR 2741810 6/1997  
(Continued)

*Primary Examiner* — Imani Hayman  
(74) *Attorney, Agent, or Firm* — Ascentage Patent Law, LLC; Travis Lee Johnson; David S. Einfeldt

(57) **ABSTRACT**

A portable auto-injector configured to store a liquid component in a first chamber separately from a dry medication in a second chamber, wherein a first actuation mechanism opens a valve allowing for the initiation of a mixing step prior to injection. An extendable needle guard is provided over the delivery assembly which prevents premature injection as well as inadvertent sticks or other cross contamination of a needle. The needle guard can also form part of a secondary trigger mechanism which injects the mixed components after the mixing stage is complete.

**1 Claim, 40 Drawing Sheets**

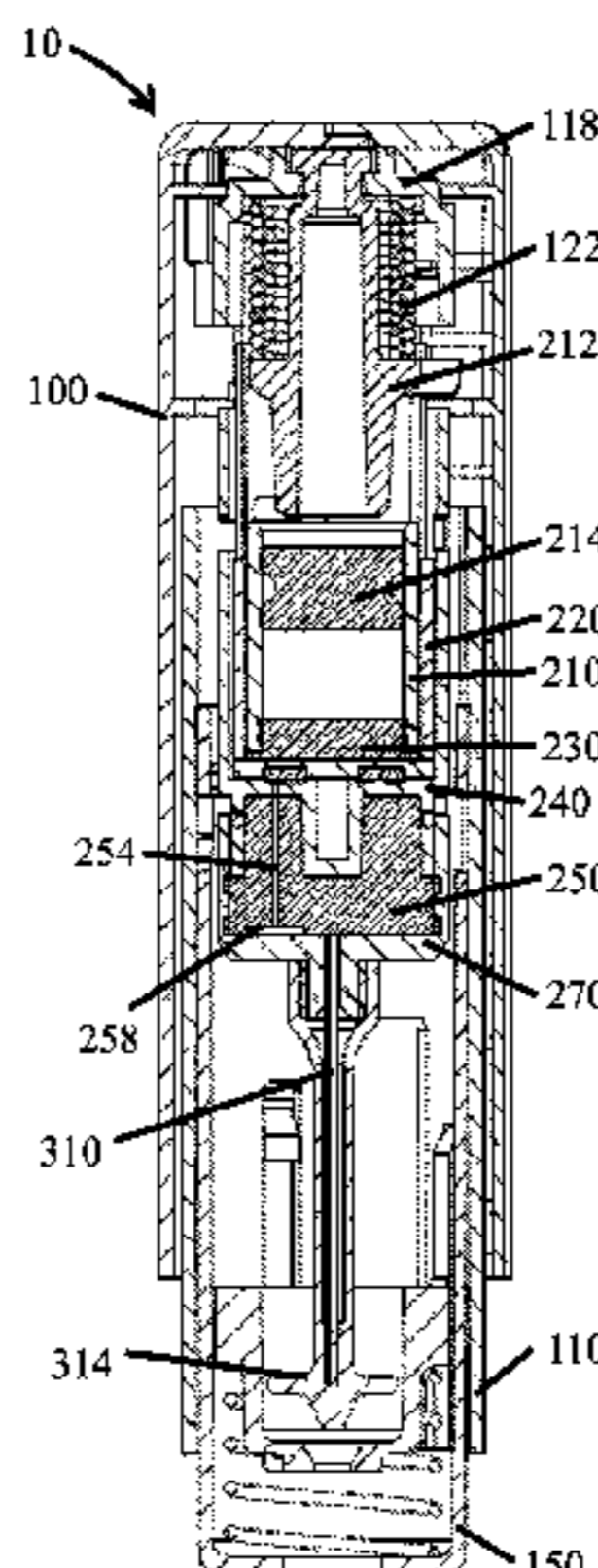

**Related U.S. Application Data**

filed on Feb. 27, 2015, provisional application No. 62/061,664, filed on Aug. 10, 2014, provisional application No. 62/120,792, filed on Feb. 25, 2015, provisional application No. 62/204,940, filed on Aug. 13, 2015.

(51) **Int. Cl.**

*A61M 5/20* (2006.01)  
*A61M 5/32* (2006.01)  
*A61M 5/315* (2006.01)

(52) **U.S. Cl.**

CPC ..... *A61M 5/31596* (2013.01); *A61M 5/3204* (2013.01); *A61M 39/22* (2013.01)

(56)

**References Cited**

U.S. PATENT DOCUMENTS

4,031,892 A 6/1977 Hurschman  
 4,060,082 A 11/1977 Lindberg et al.  
 4,529,403 A 7/1985 Kamstra  
 4,643,721 A 2/1987 Brunet  
 4,755,169 A 7/1988 Sarnoff  
 5,360,410 A 11/1994 Wacks  
 5,569,193 A 10/1996 Hofstetter  
 5,704,918 A 1/1998 Higashikawa  
 5,899,881 A 5/1999 Grimard et al.  
 6,149,628 A 11/2000 Szapiro et al.  
 6,309,372 B1 10/2001 Fischer et al.  
 6,641,561 B1 11/2003 Hill et al.  
 6,656,150 B2 12/2003 Hill et al.  
 6,770,052 B2 8/2004 Hill et al.  
 6,793,646 B1 9/2004 Giambattista et al.  
 6,852,103 B2 2/2005 Fowles et al.  
 6,953,445 B2 10/2005 Wilmot et al.  
 7,449,012 B2 11/2008 Young et al.  
 7,544,189 B2 6/2009 Griffiths  
 7,556,614 B2 7/2009 Griffiths et al.  
 7,608,055 B2 10/2009 Griffiths et al.  
 7,612,887 B2 11/2009 Choi et al.  
 7,621,887 B2 11/2009 Griffiths et al.  
 7,678,073 B2 3/2010 Griffiths et al.  
 7,749,190 B2 7/2010 Griffiths et al.  
 7,757,370 B2 7/2010 Griffiths  
 7,776,015 B2 8/2010 Sadowski et al.  
 7,947,742 B2 5/2011 Batycky et al.  
 8,057,427 B2 11/2011 Griffiths et al.  
 8,092,420 B2 1/2012 Bendek et al.  
 8,123,719 B2 2/2012 Edwards et al.  
 8,177,758 B2 5/2012 Brooks, Jr. et al.  
 8,187,220 B2 5/2012 Griffiths et al.  
 8,251,947 B2 8/2012 Kramer et al.  
 8,496,619 B2 7/2013 Kramer et al.  
 8,506,526 B2 8/2013 Griffiths et al.  
 8,568,367 B2 10/2013 Griffiths et al.  
 8,613,720 B2 12/2013 Bendek et al.  
 8,632,504 B2 1/2014 Young  
 RE44,847 E 4/2014 Sadowski et al.  
 8,696,618 B2 4/2014 Kramer et al.  
 8,814,834 B2 8/2014 Sund et al.  
 8,870,827 B2 10/2014 Young et al.

8,945,053 B2 2/2015 Vogt et al.  
 9,364,610 B2 6/2016 KraMer et al.  
 9,364,611 B2 6/2016 KraMer et al.  
 2002/0046563 A1 2/2002 Hill et al.  
 2002/0042592 A1 4/2002 Wilmot et al.  
 2002/0049406 A1 4/2002 Hill et al.  
 2002/0049407 A1 4/2002 Hill et al.  
 2005/0074498 A1 4/2005 Tarara et al.  
 2005/0148933 A1 7/2005 Raven et al.  
 2005/0177100 A1 8/2005 Harper et al.  
 2006/0079834 A1 4/2006 Tennican et al.  
 2007/0116729 A1 5/2007 Nageswara  
 2007/0202163 A1 8/2007 Rawas-Qalaji et al.  
 2007/0293582 A1 12/2007 Hill  
 2008/0103490 A1 5/2008 Edwards et al.  
 2008/0281271 A1 11/2008 Griffiths et al.  
 2009/0171311 A1 7/2009 Genosar et al.  
 2010/0228190 A1 9/2010 Griffiths et al.  
 2010/0318035 A1 12/2010 Edwards et al.  
 2011/0092906 A1 4/2011 Bottger et al.  
 2011/0092917 A1 4/2011 Wei et al.  
 2011/0237681 A1 9/2011 Patycky et al.  
 2012/0016296 A1 1/2012 Charles  
 2012/0130318 A1 5/2012 Young  
 2012/0179137 A1 7/2012 Bartlett et al.  
 2012/0302989 A1 11/2012 Kramer et al.  
 2013/0018310 A1 1/2013 Boyd et al.  
 2013/0023822 A1 1/2013 Edwards et al.  
 2013/0060232 A1 3/2013 Aldon et al.  
 2013/0018313 A1 7/2013 Kramer et al.  
 2013/0178823 A1 7/2013 Buchine et al.  
 2013/0274707 A1 10/2013 Wilmont et al.  
 2013/0289791 A1 10/2013 Kerrigan et al.  
 2013/0317477 A1 11/2013 Edwards et al.  
 2013/0331788 A1 12/2013 Kramer et al.  
 2014/0088512 A1 3/2014 Quinn  
 2014/0276385 A1 9/2014 Buchine et al.  
 2014/0276430 A1 9/2014 Baker et al.  
 2014/0336589 A1 11/2014 Sund et al.  
 2015/0011975 A1 1/2015 Anderson et al.  
 2015/0174323 A1 6/2015 Edwards et al.  
 2015/0367073 A1 12/2015 Standley et al.  
 2015/0374925 A1 12/2015 Standley et al.  
 2016/0220764 A1 4/2016 Durvasula et al.

FOREIGN PATENT DOCUMENTS

WO WO9208506 A1 5/1992  
 WO WO 2008/114035 A1 9/2008  
 WO WO2008114035 A1 9/2008  
 WO WO2008154092 A1 12/2008  
 WO WO2005032523 A2 1/2009  
 WO WO2009118754 A2 10/2009  
 WO WO2010068415 A1 6/2010  
 WO WO 2011/060541 A1 5/2011  
 WO WO2011060541 A1 5/2011  
 WO WO2011109340 A1 9/2011  
 WO WO2012090168 A1 5/2012  
 WO WO2012099898 A2 7/2012  
 WO WO2013063707 A1 5/2013  
 WO WO2014026694 2/2014  
 WO WO2014060563 4/2014  
 WO WO201466731 5/2014  
 WO WO14205463 12/2014

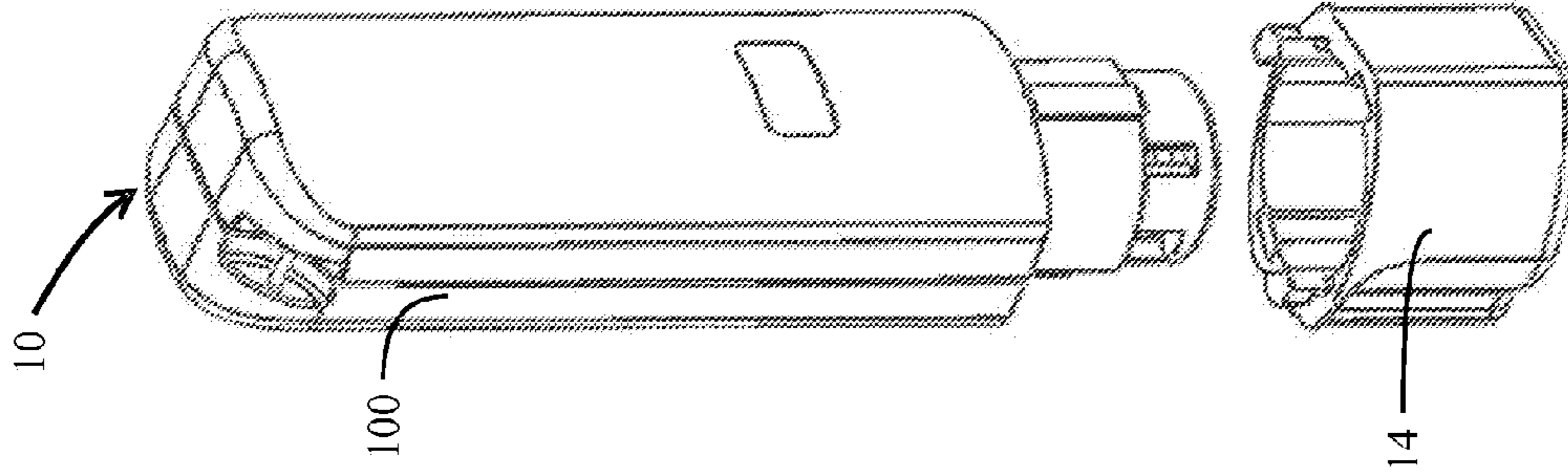

Fig. 1C

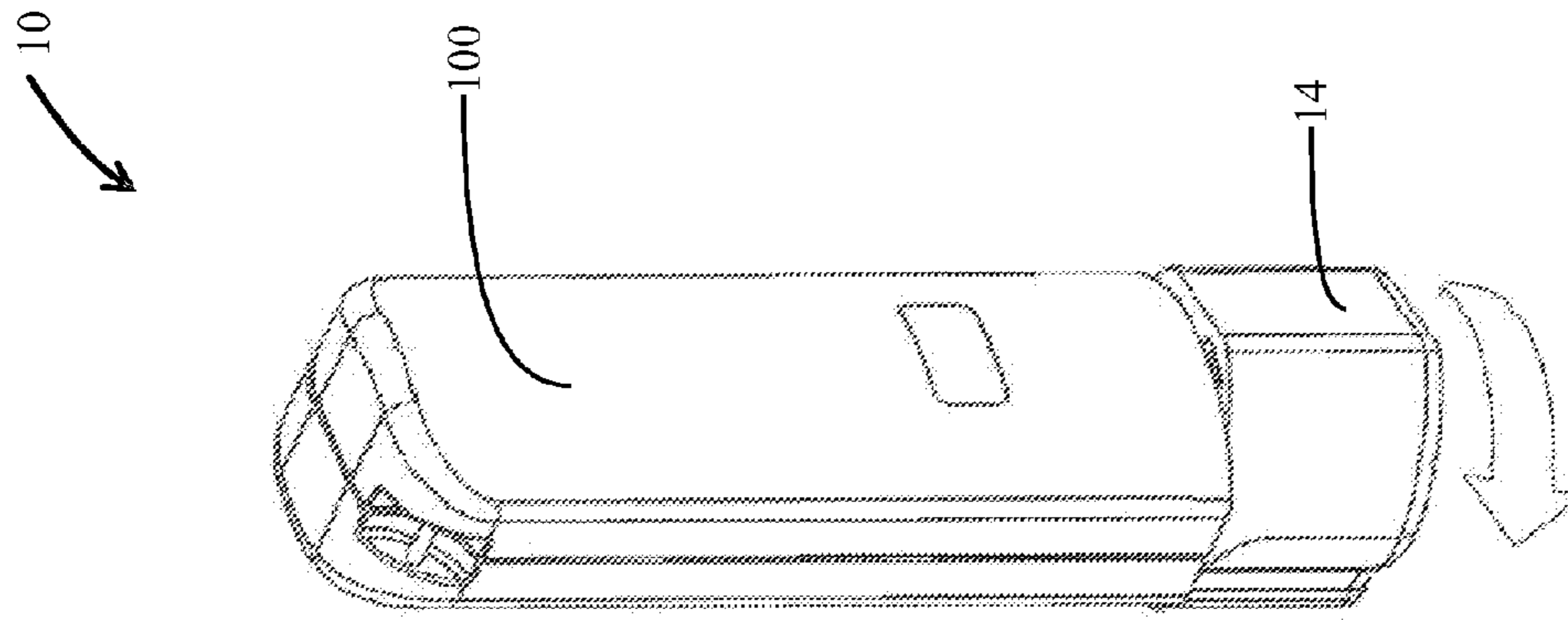

Fig. 1B

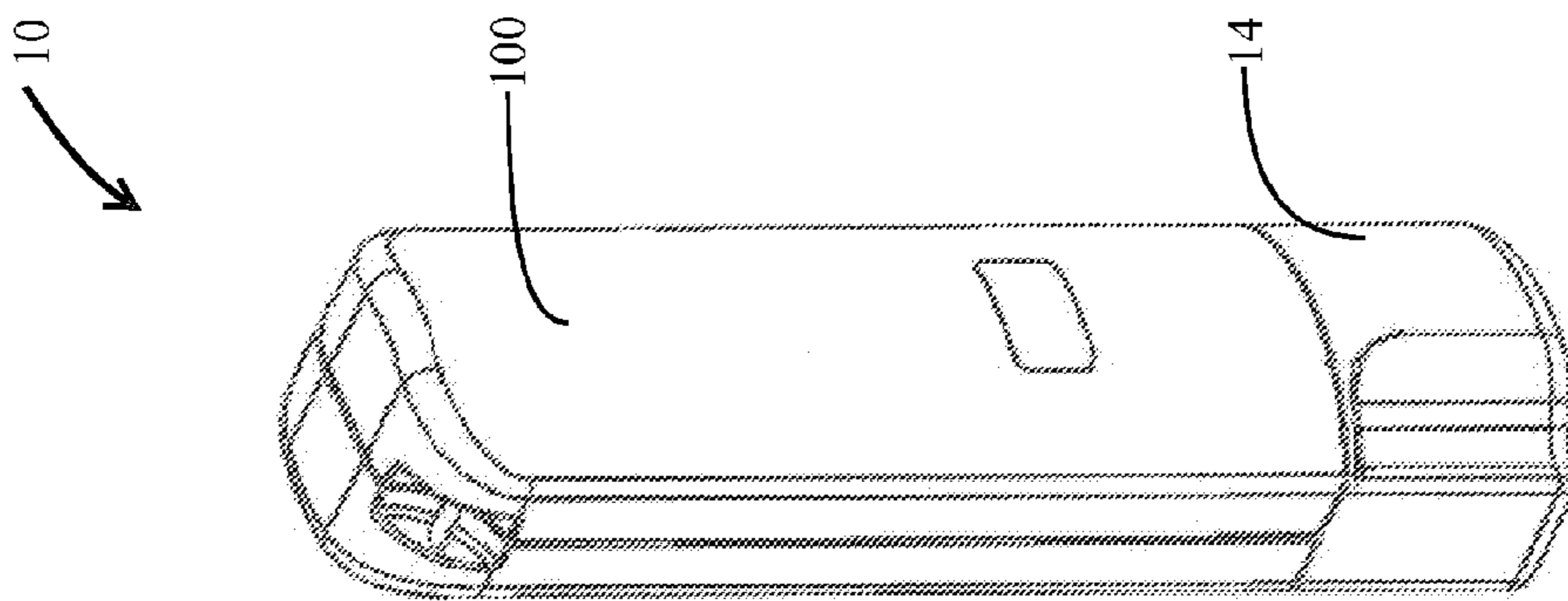

Fig. 1A

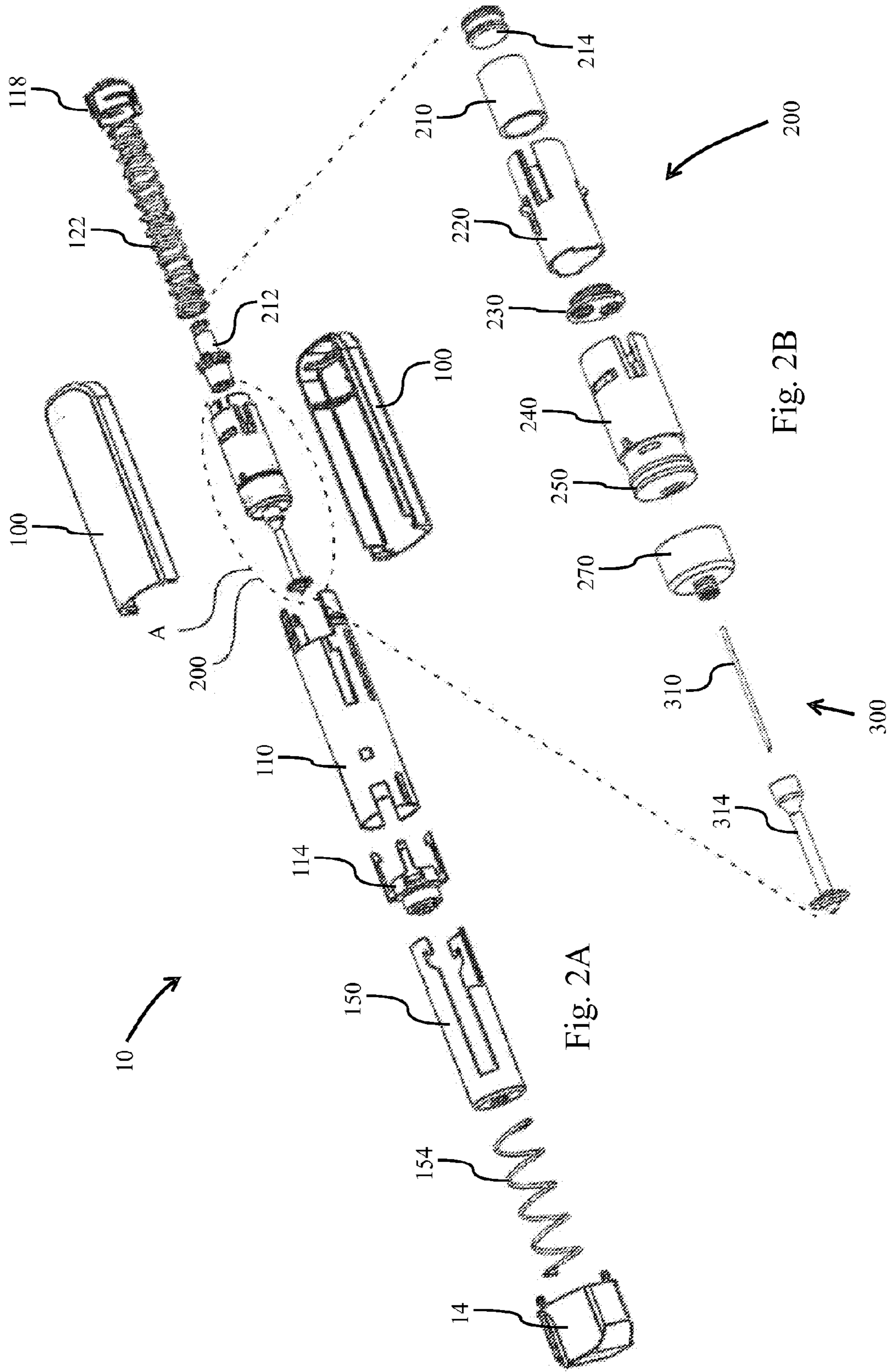

Fig. 2B

Fig. 2A

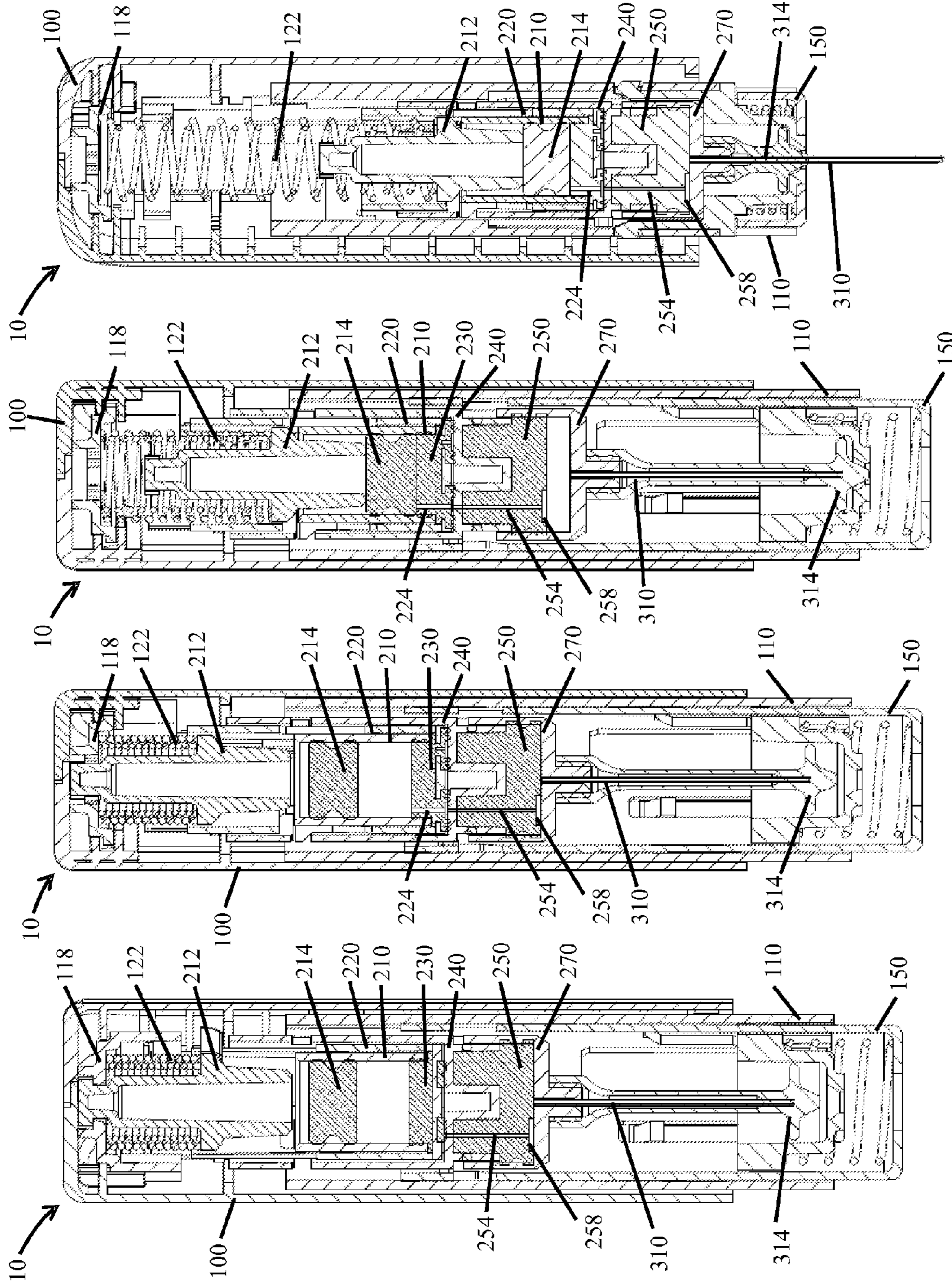

Fig. 3D

Fig. 3C

Fig. 3B

Fig. 3A

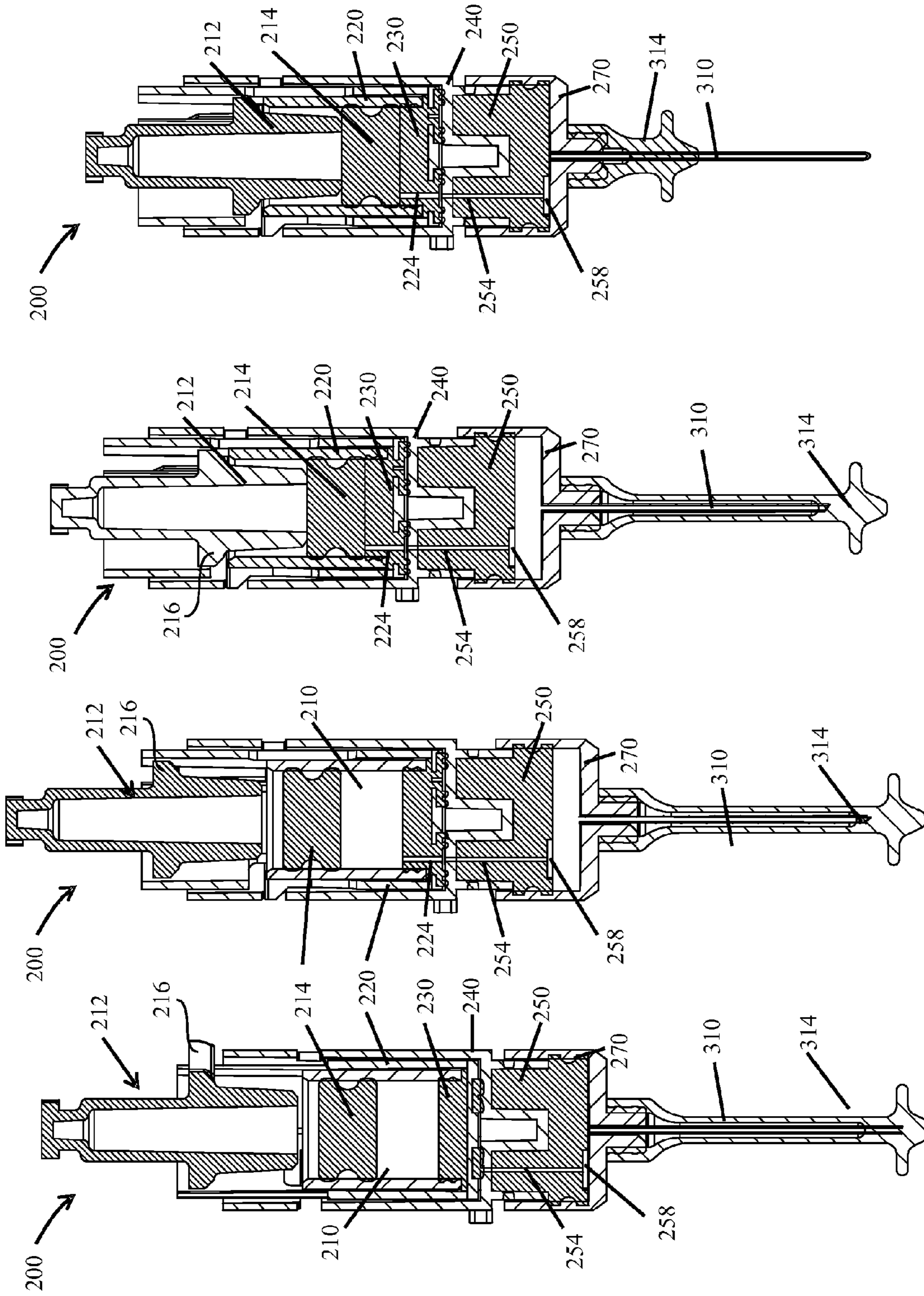

Fig. 4D

Fig. 4C

Fig. 4B

Fig. 4A

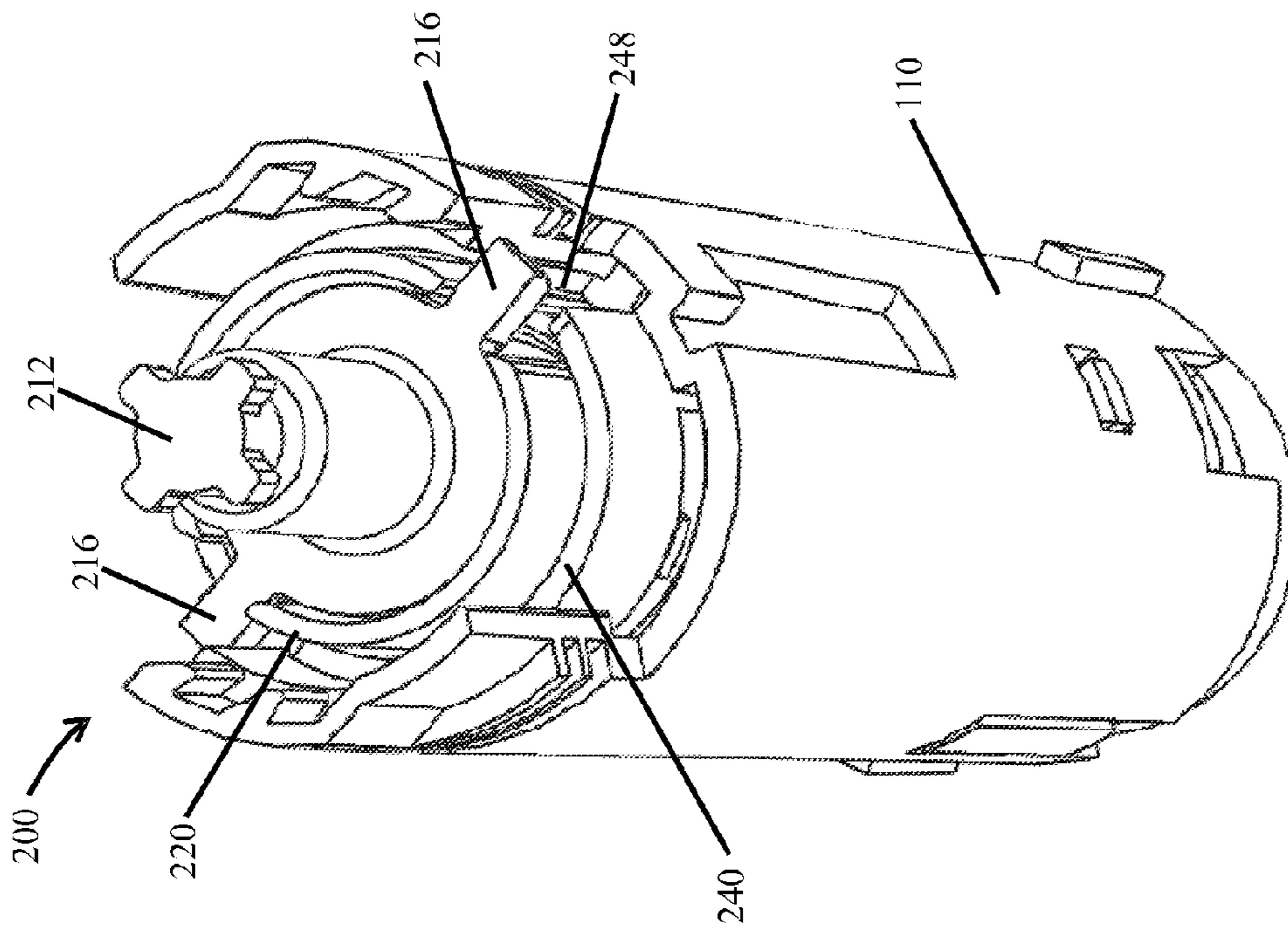

Fig. 5B

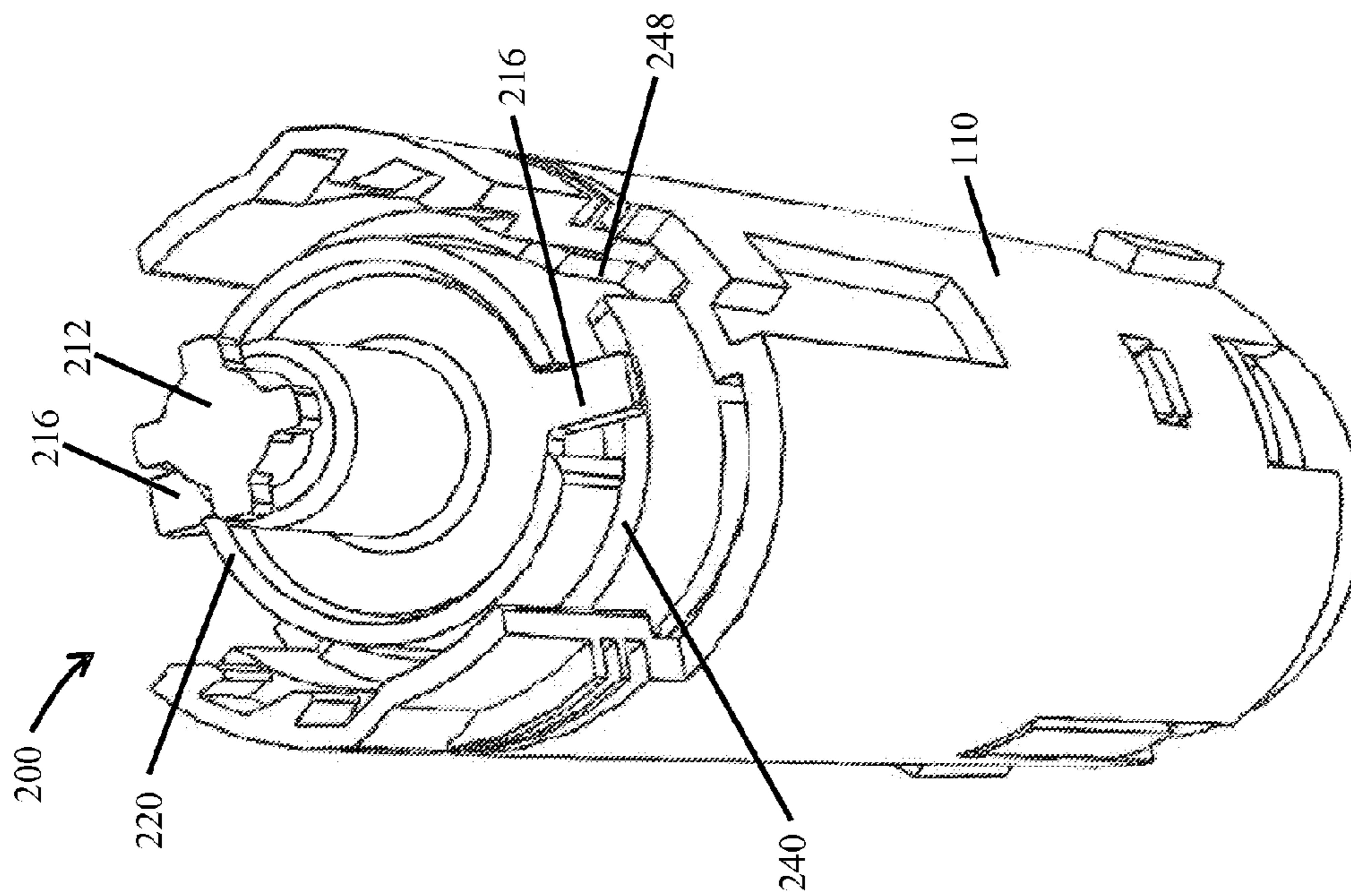

Fig. 5A

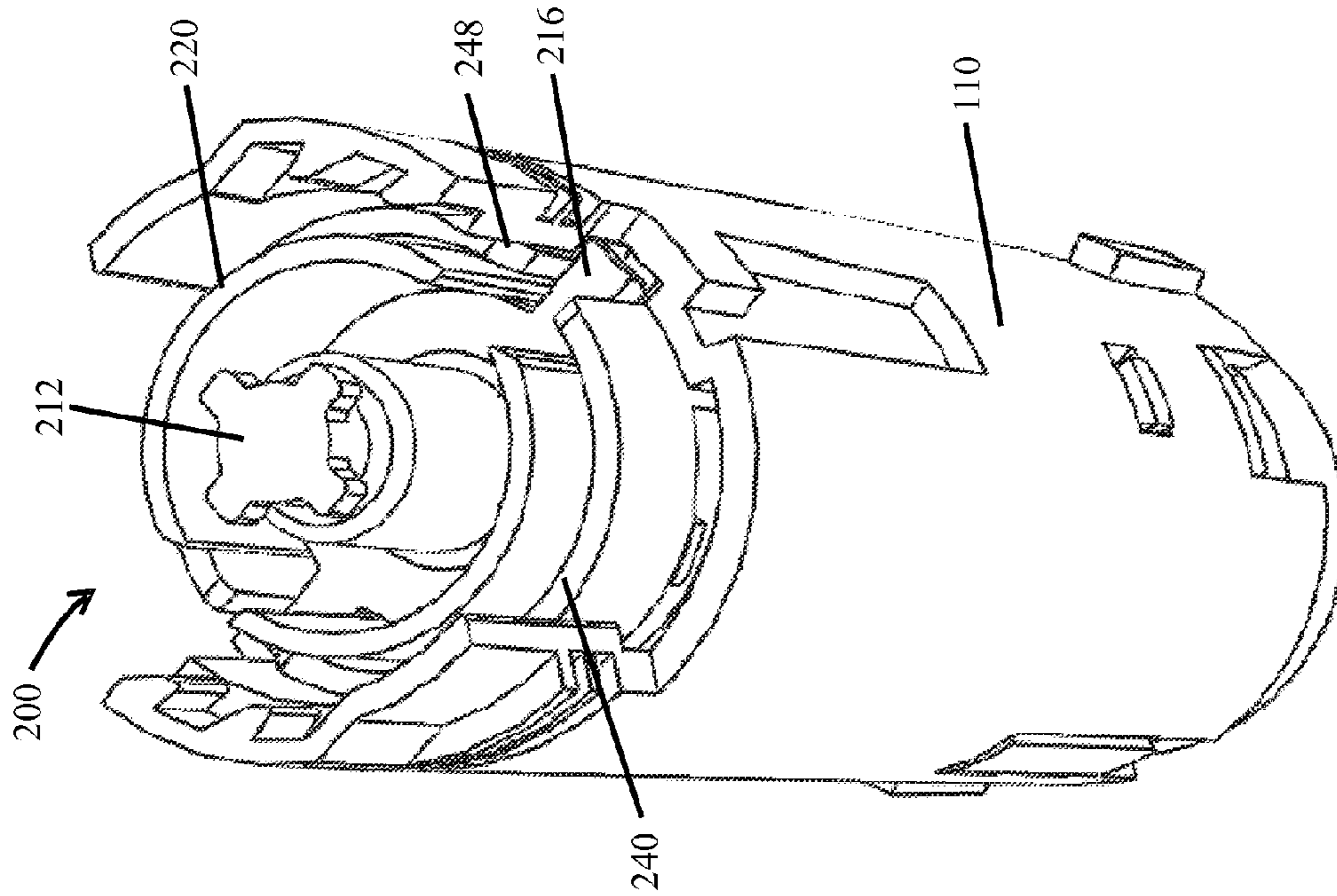

Fig. 5D

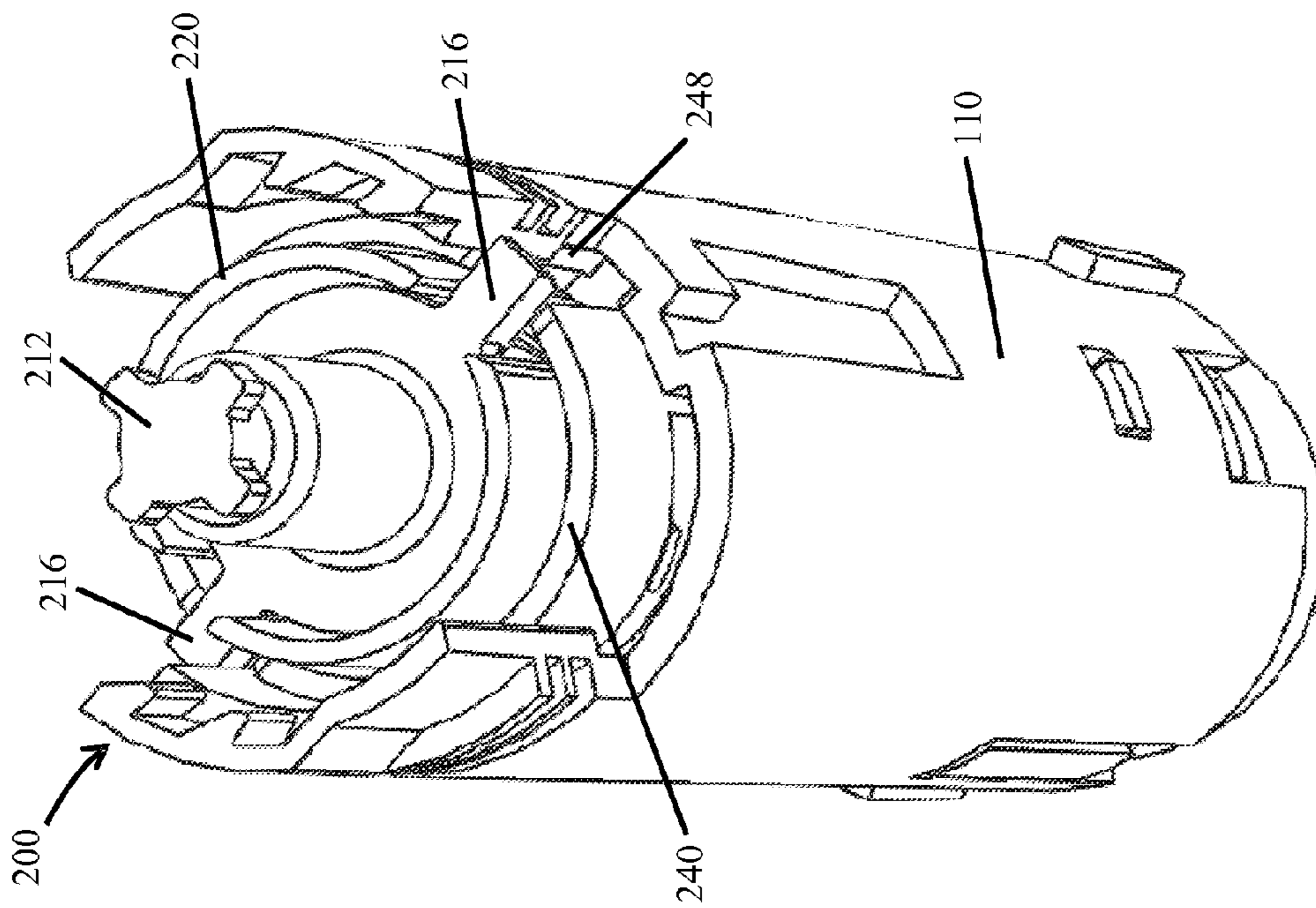

Fig. 5C



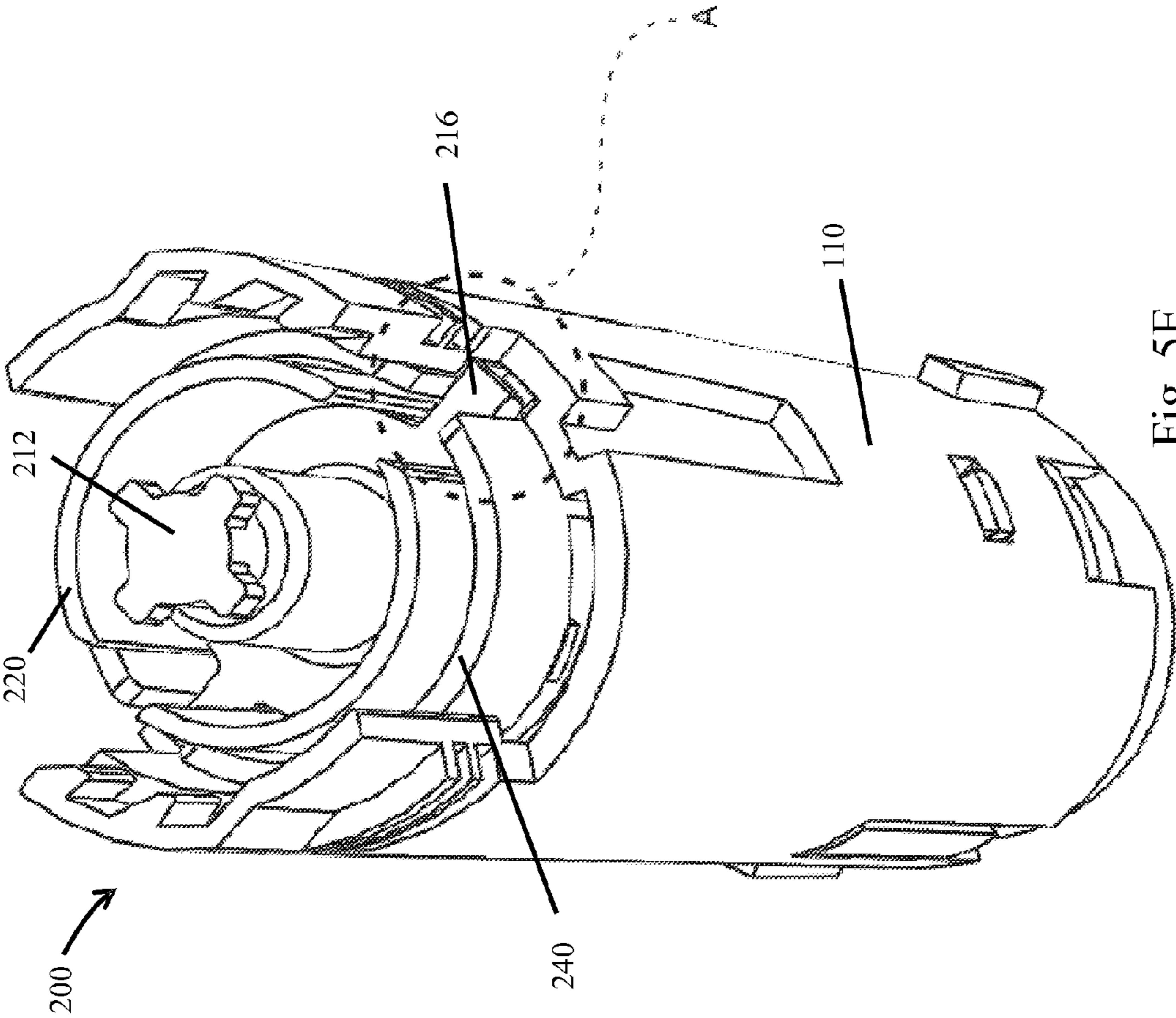

Fig. 5E

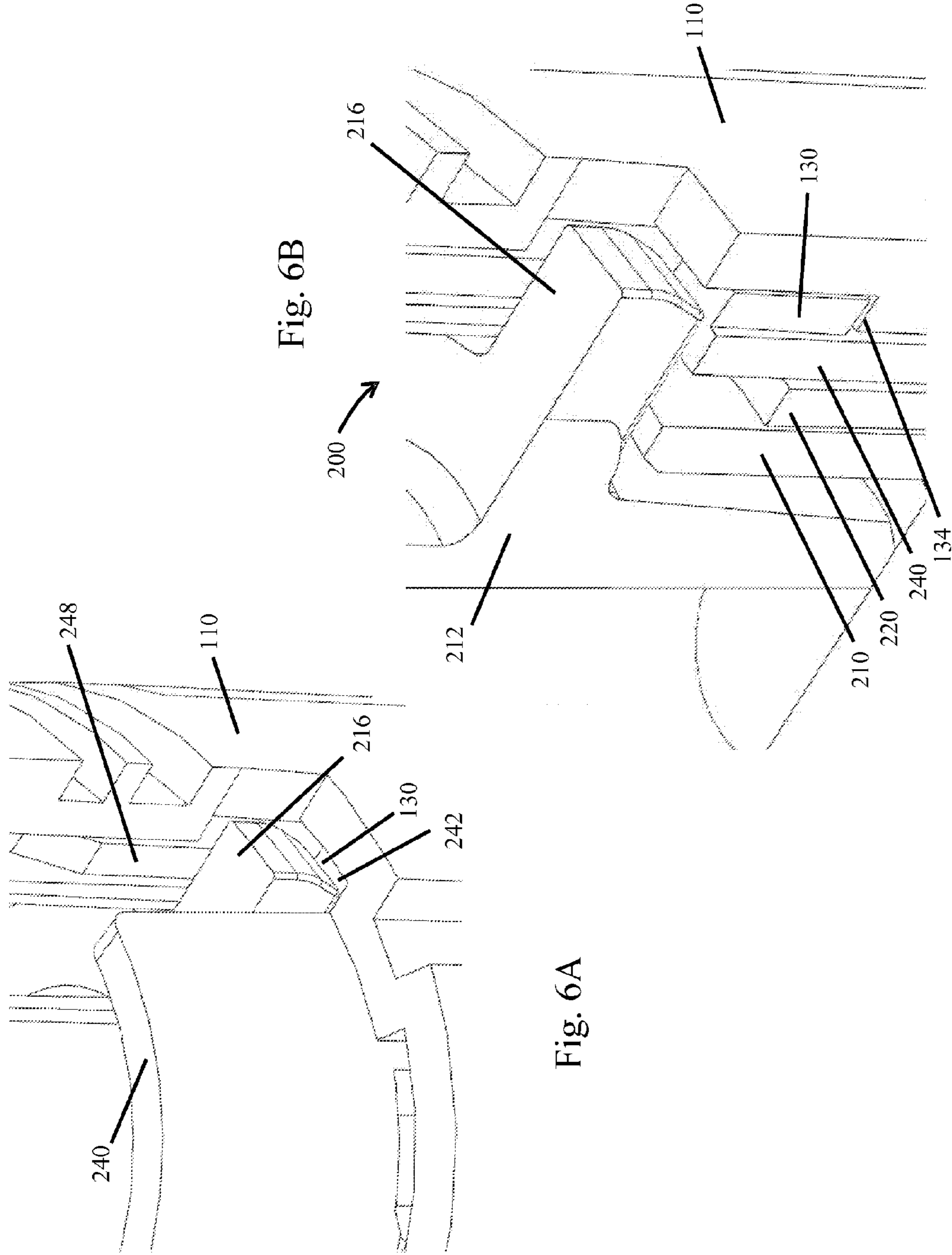

Fig. 6B

Fig. 6A

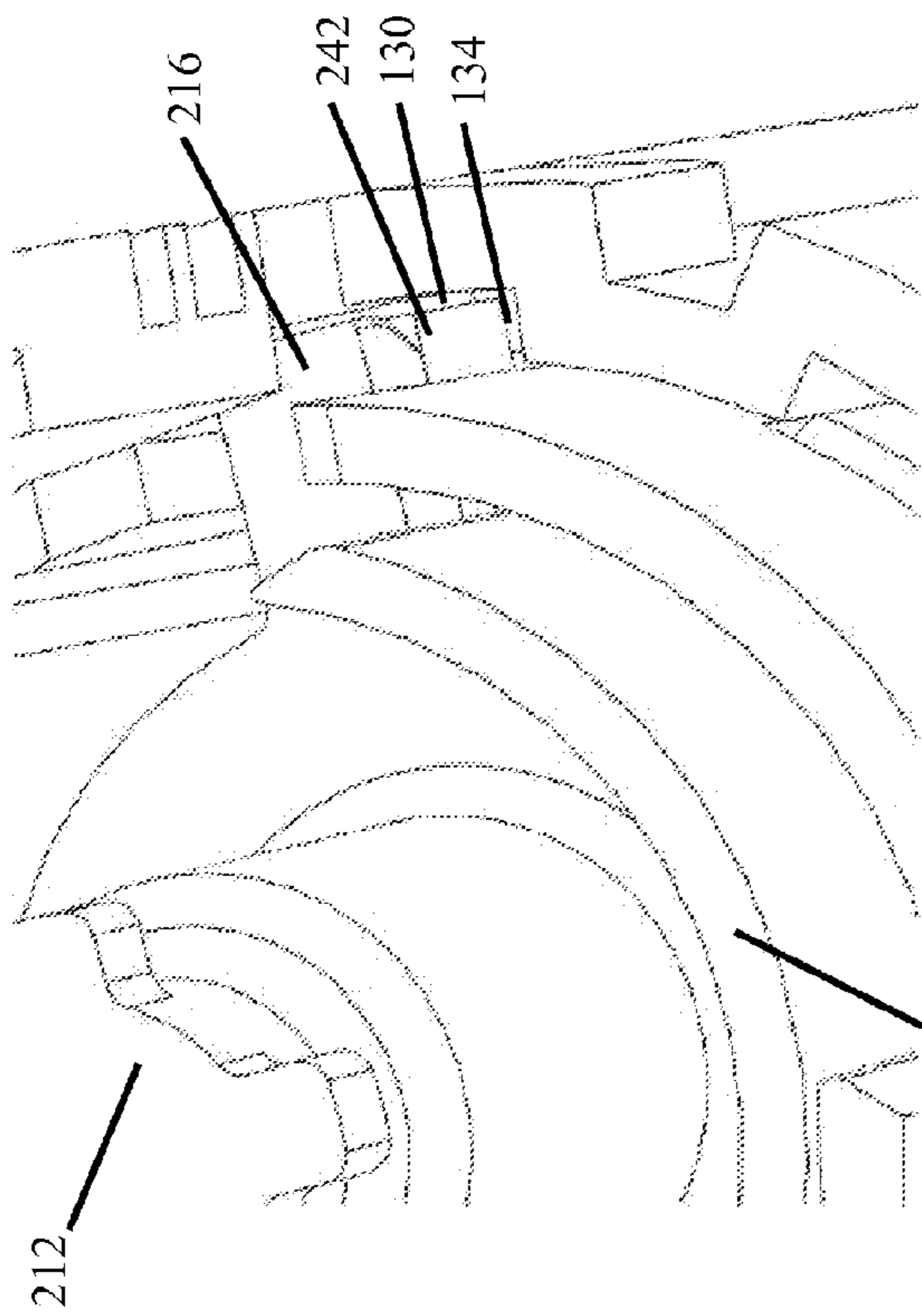

Fig. 6C

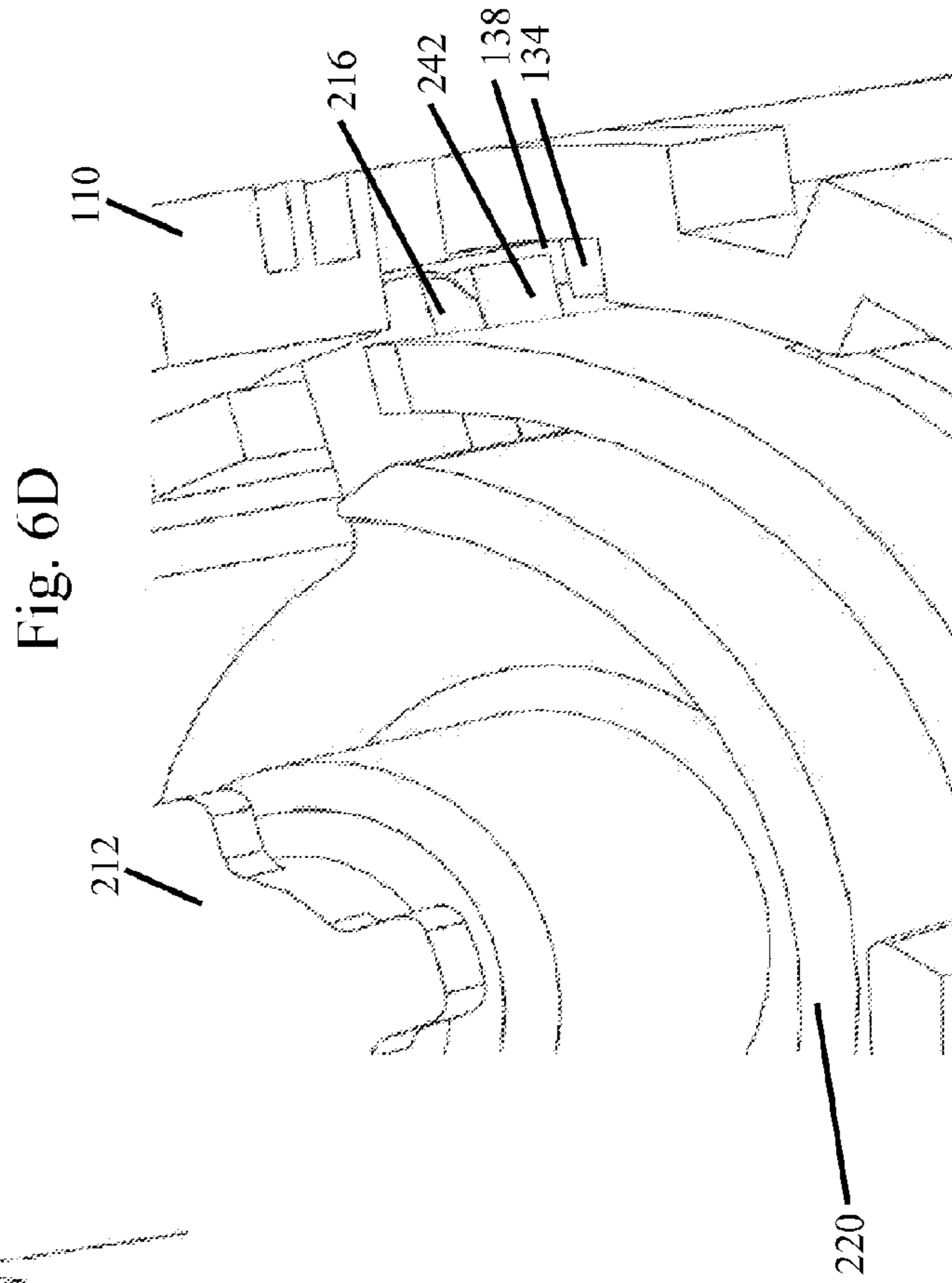

Fig. 6D

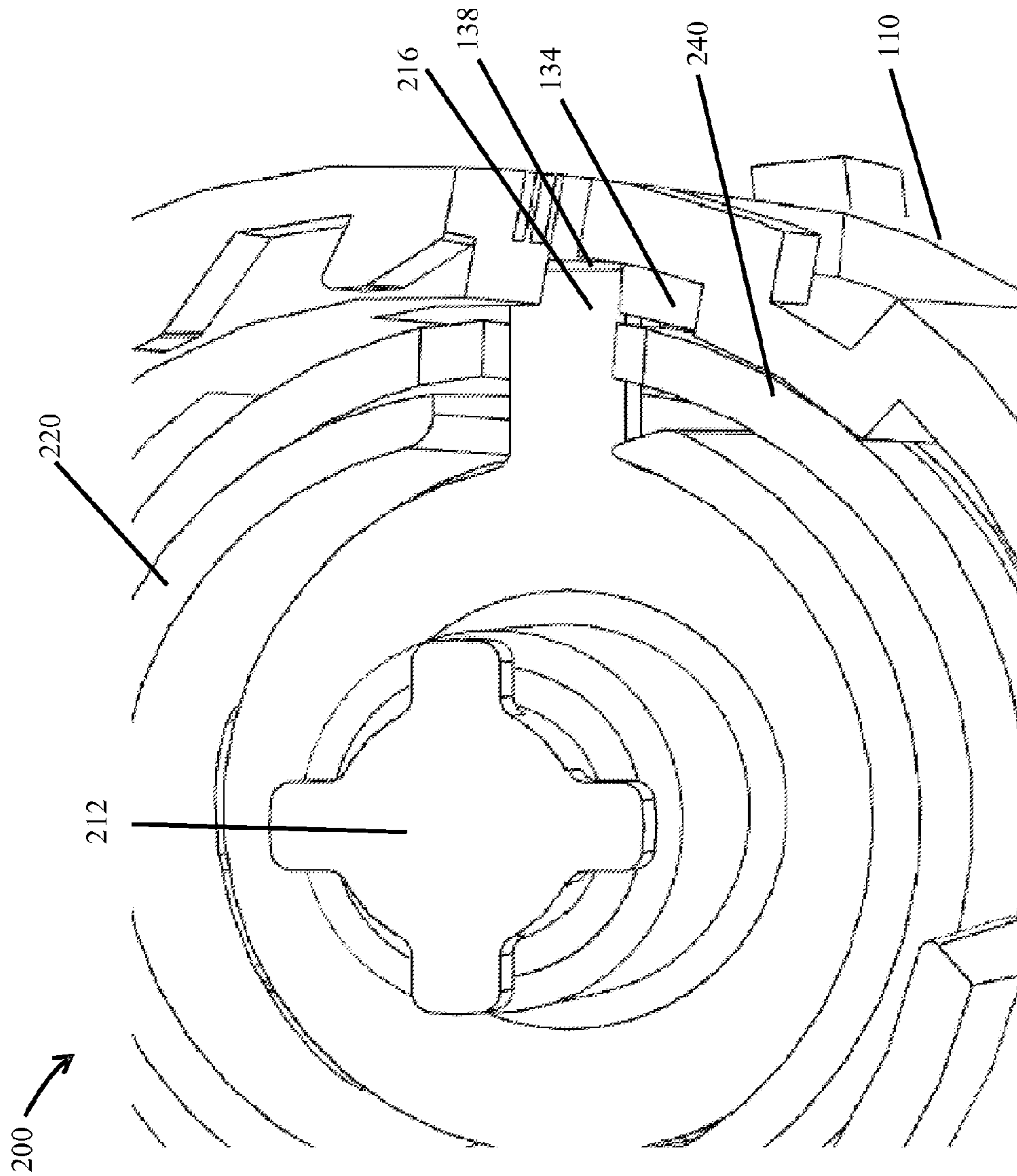

Fig. 6E

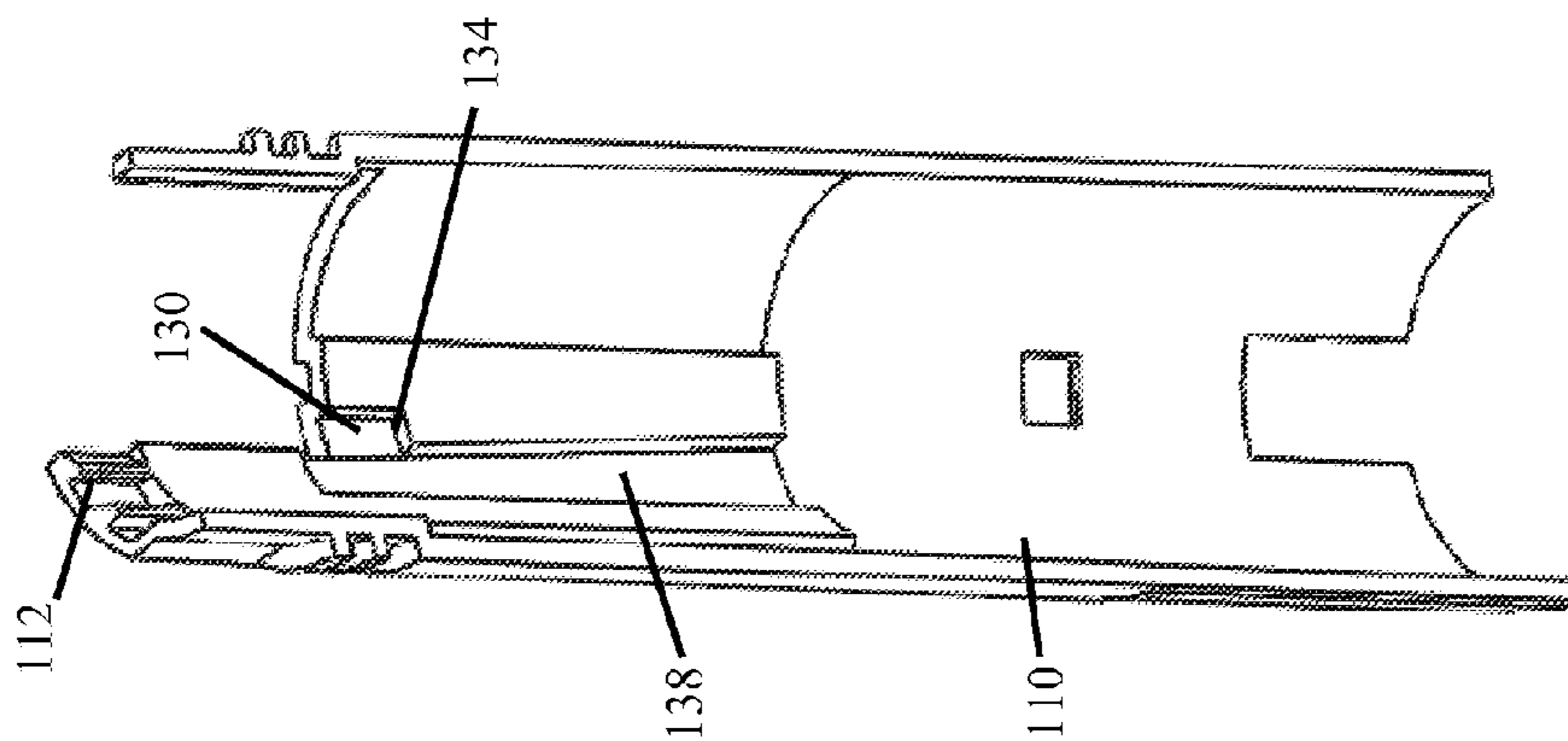

Fig. 7D

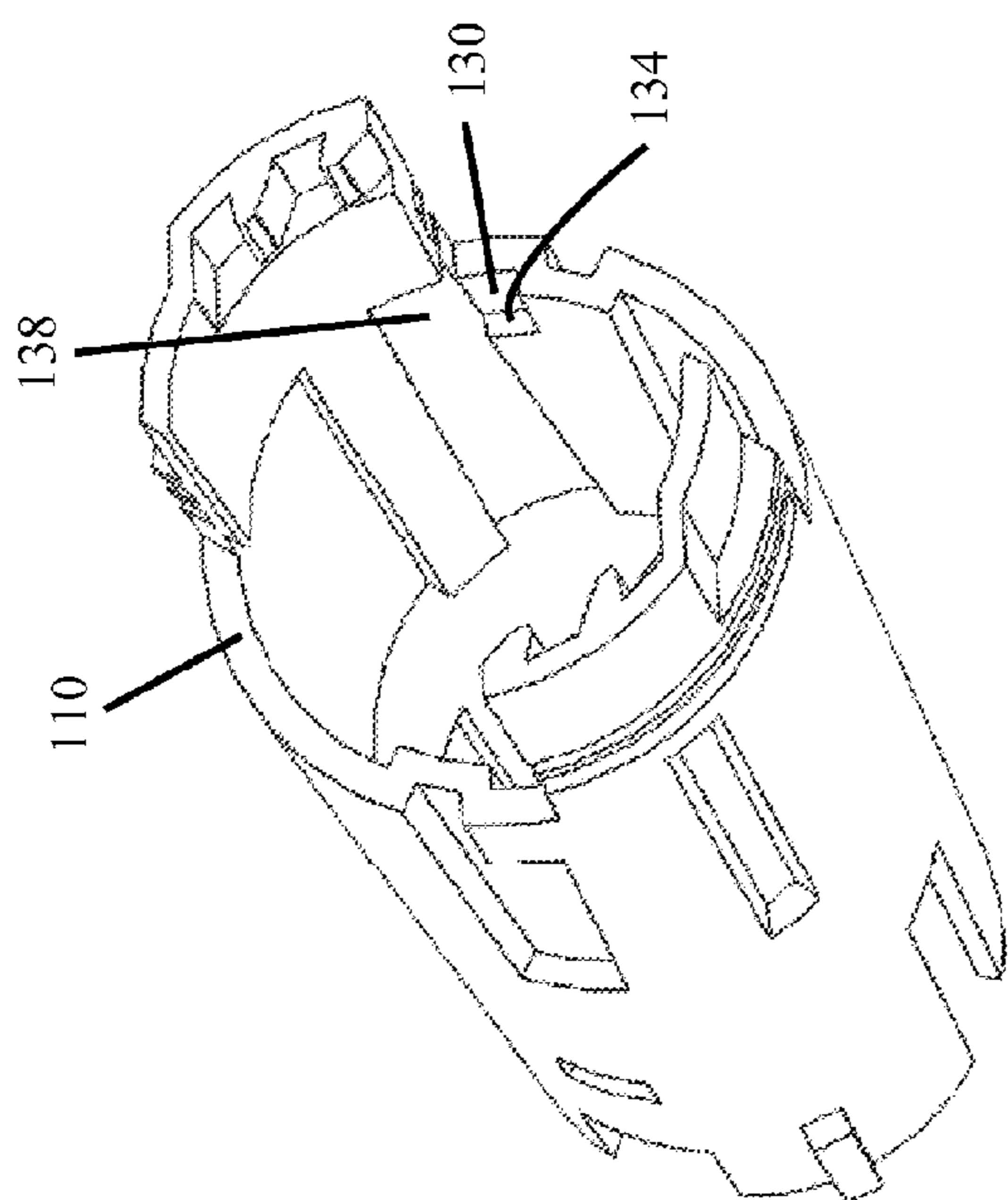

Fig. 7B

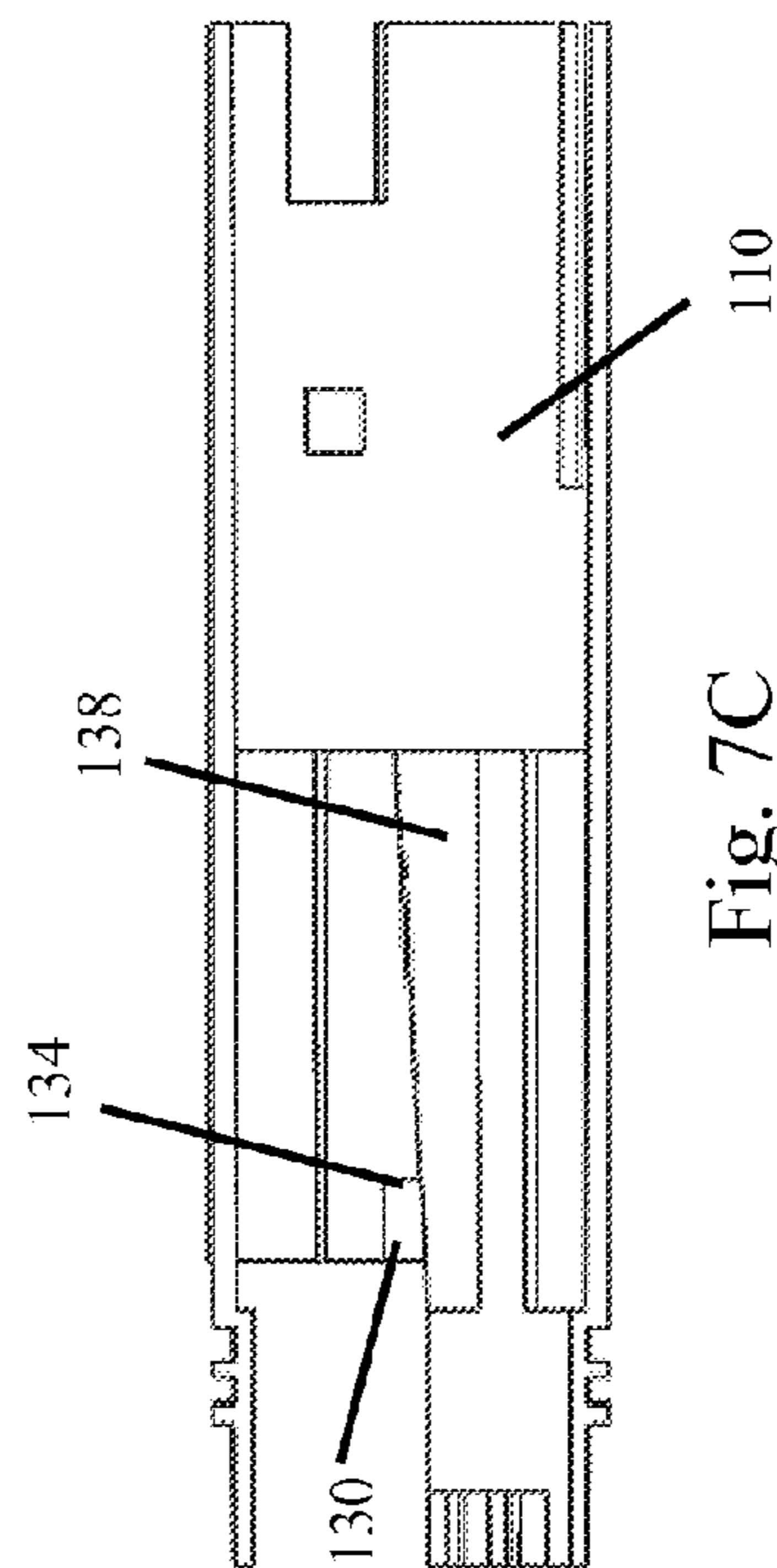

Fig. 7C

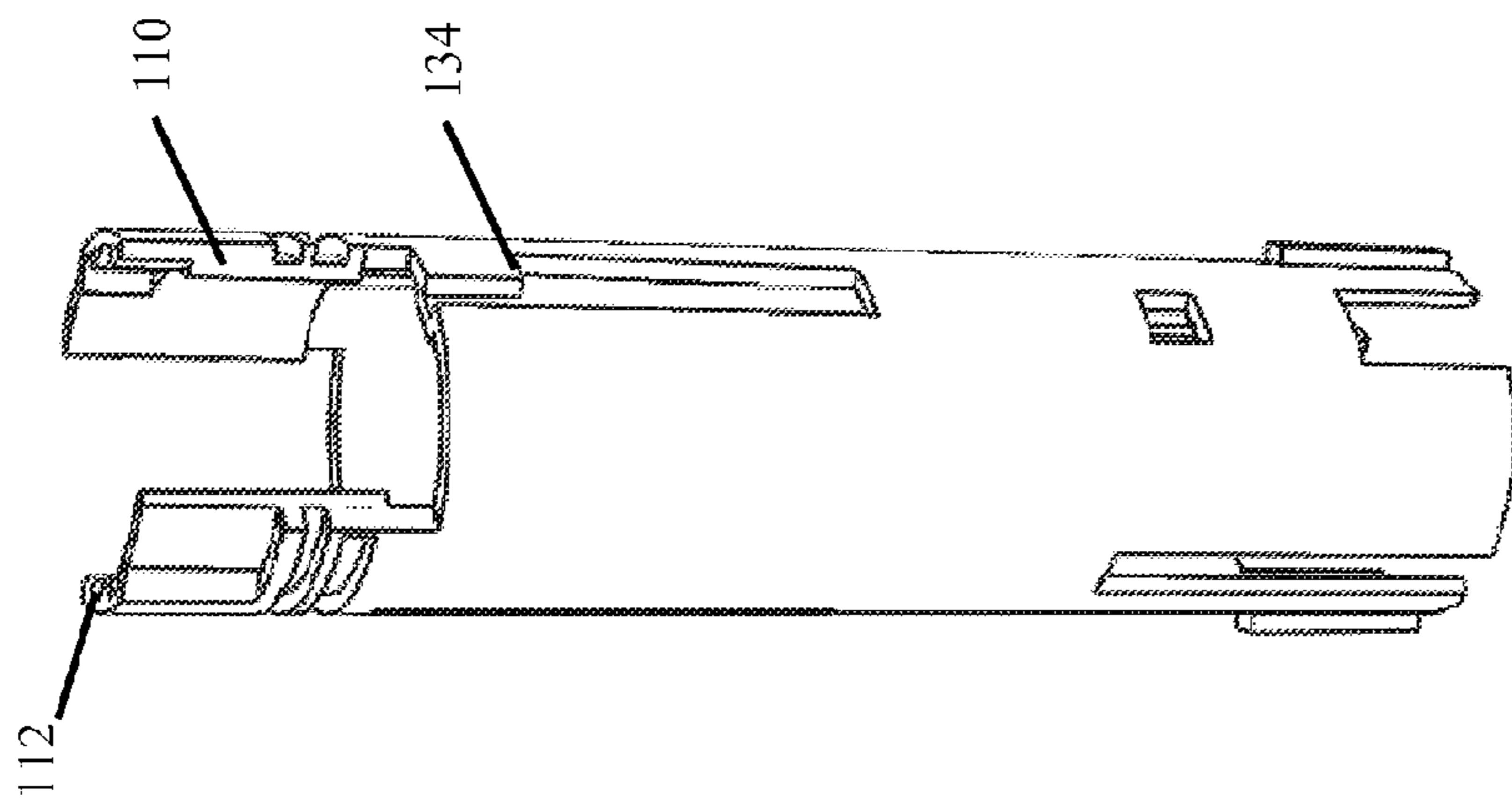
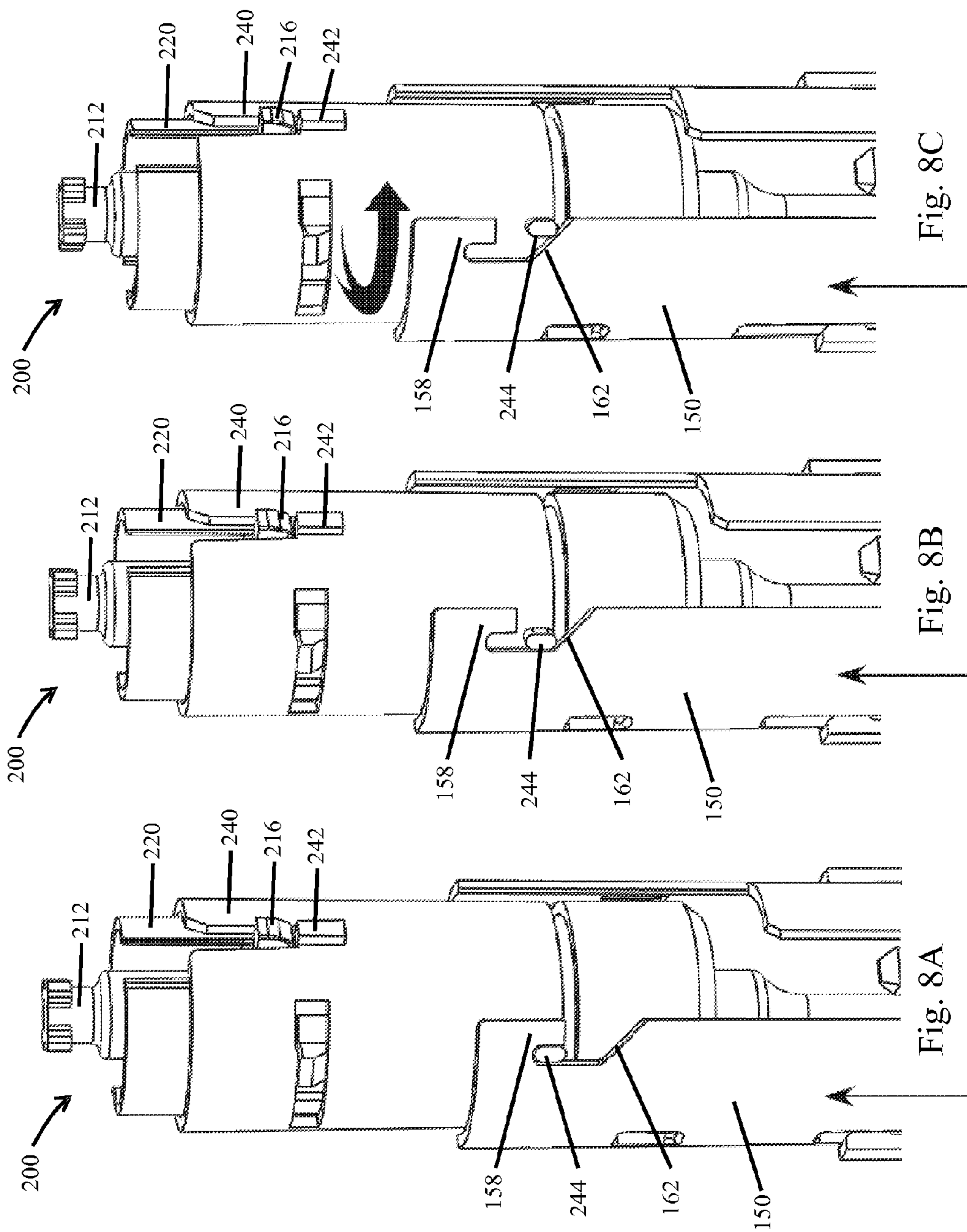

Fig. 7A



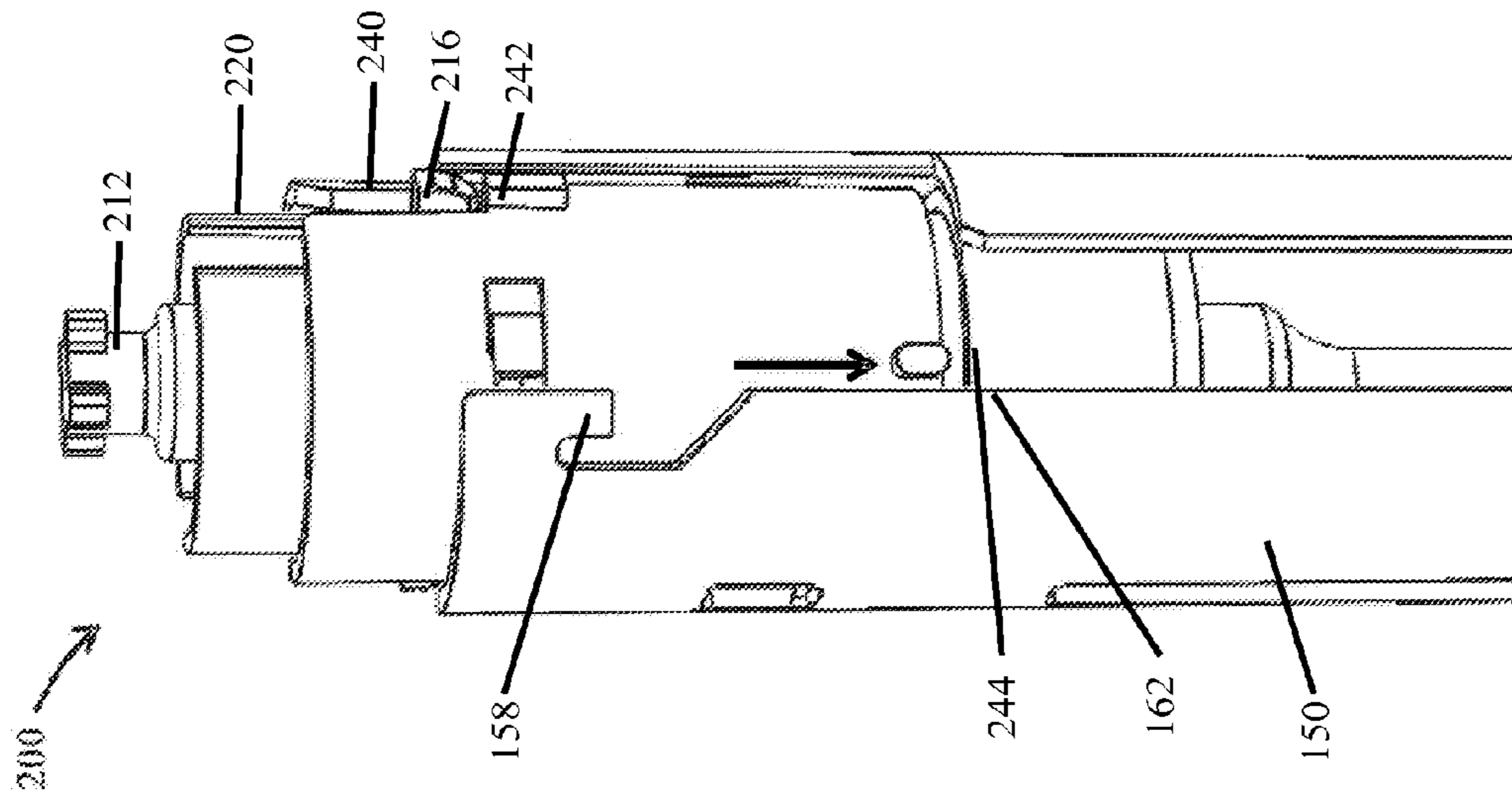

Fig. 8E

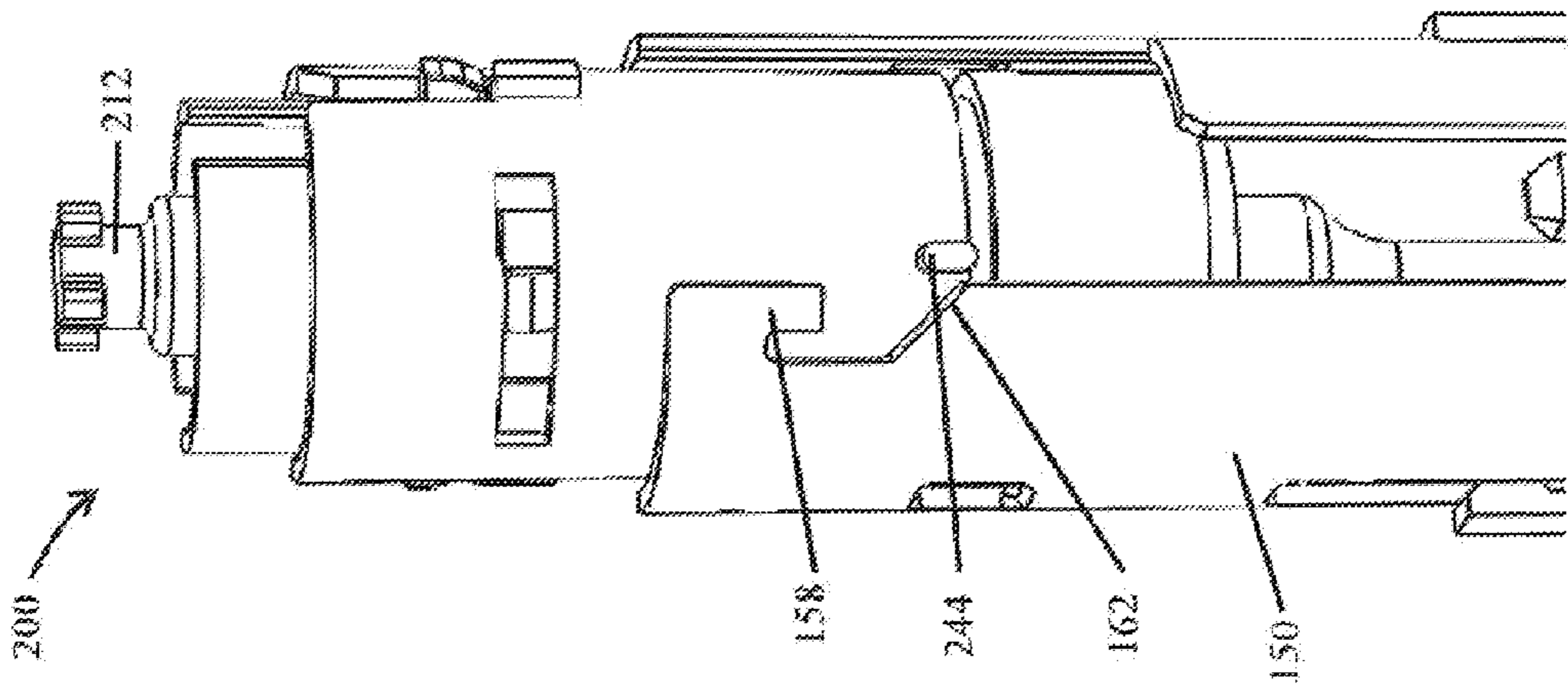
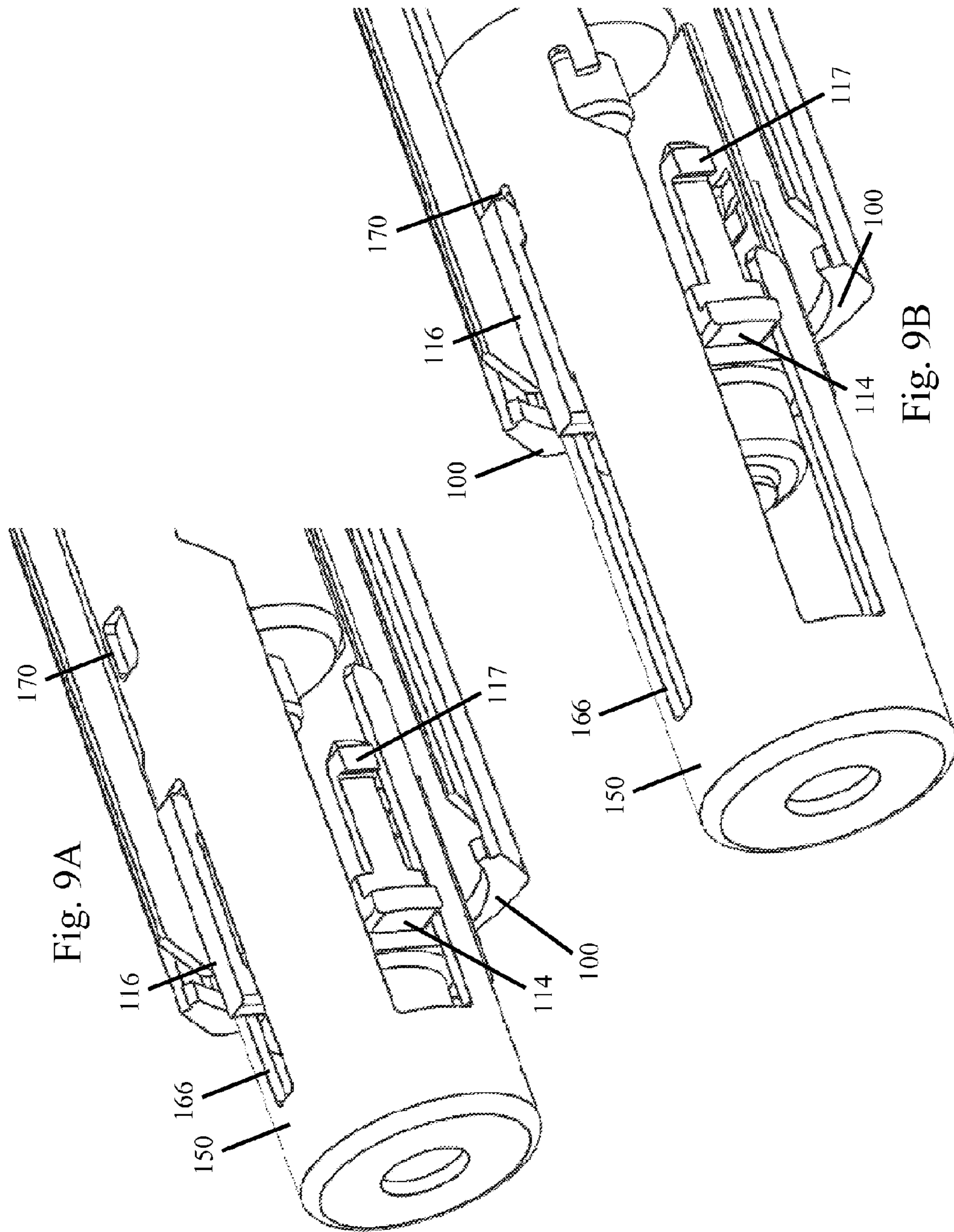
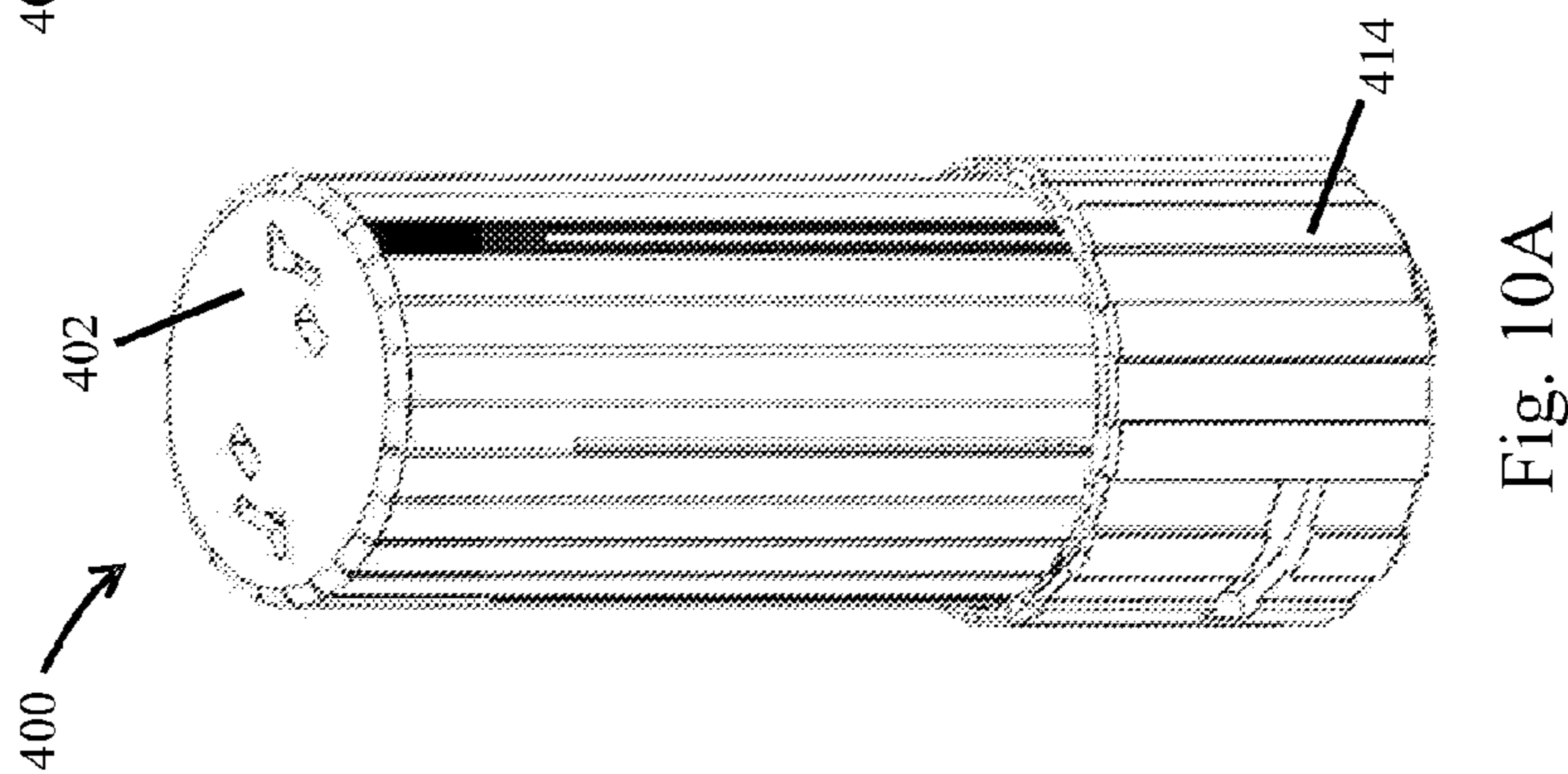
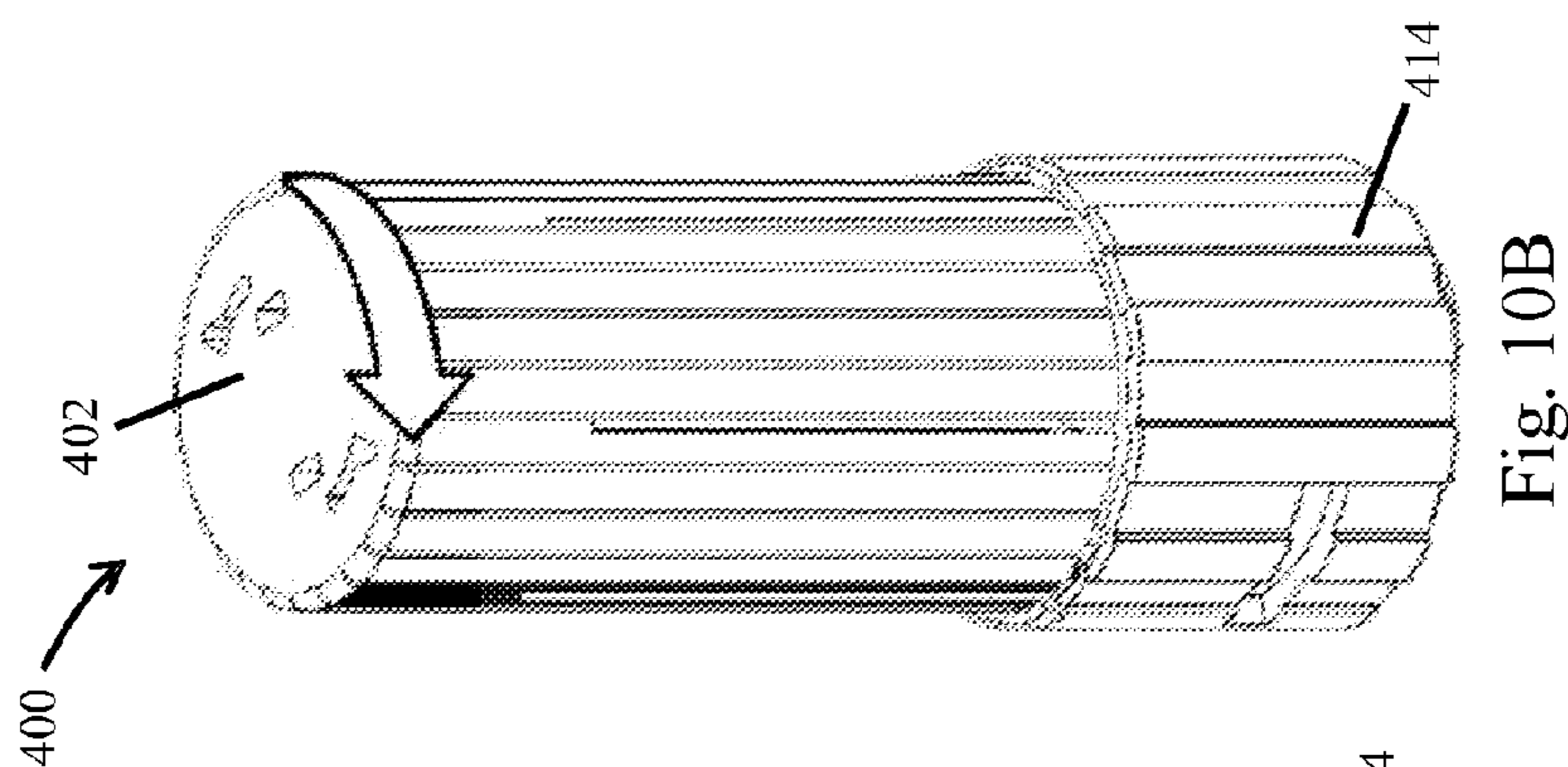
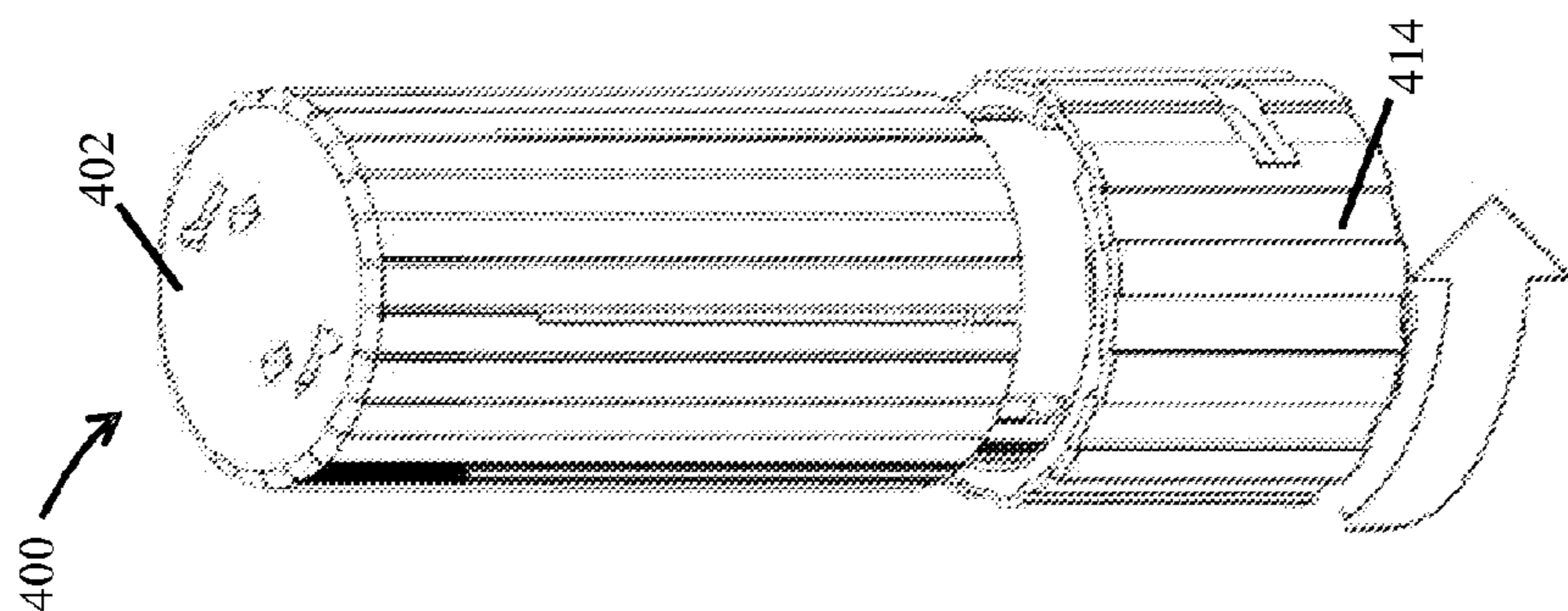
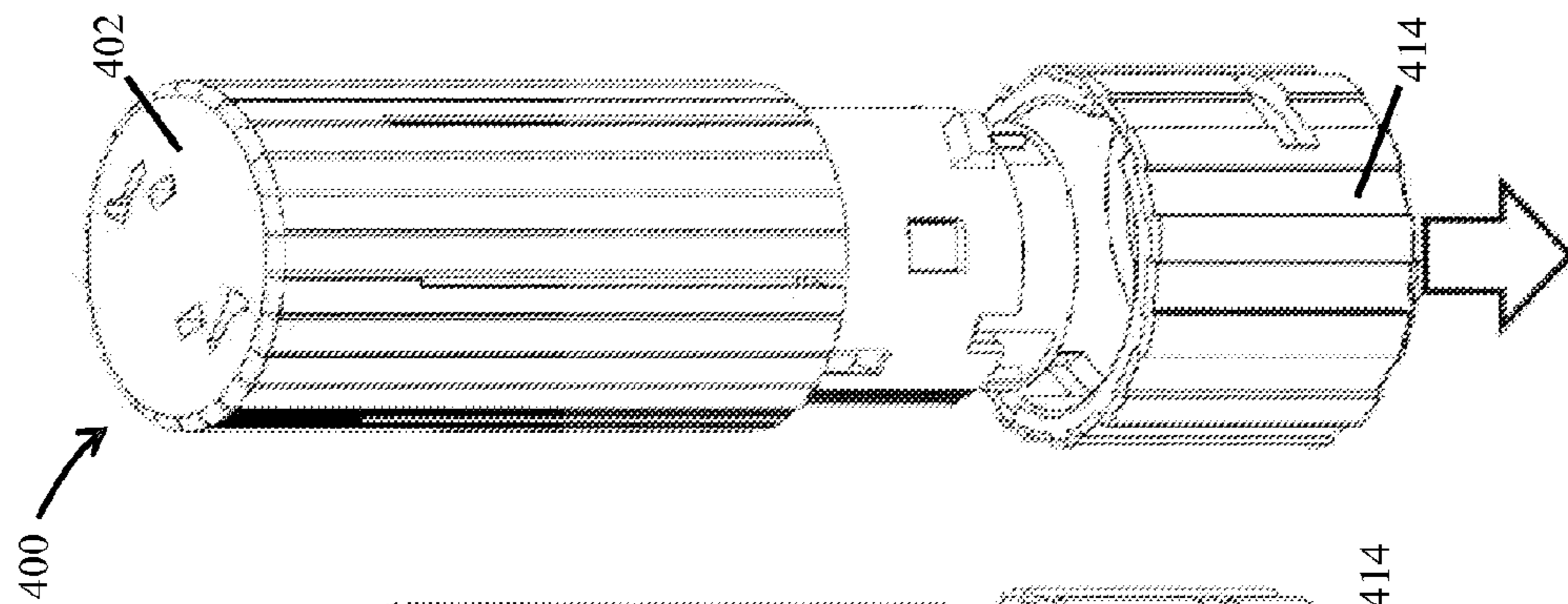

Fig. 8D







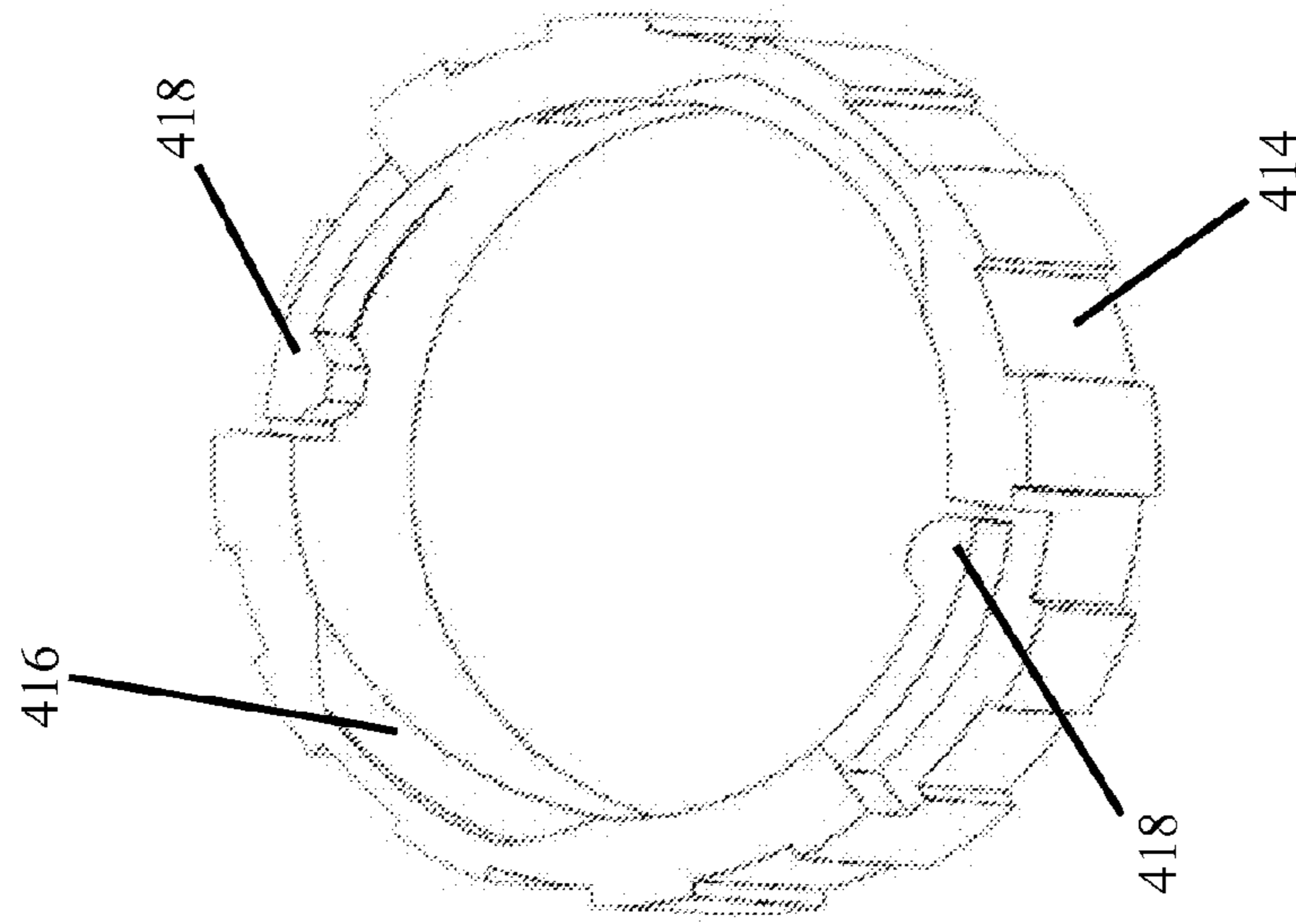

Fig. 11C

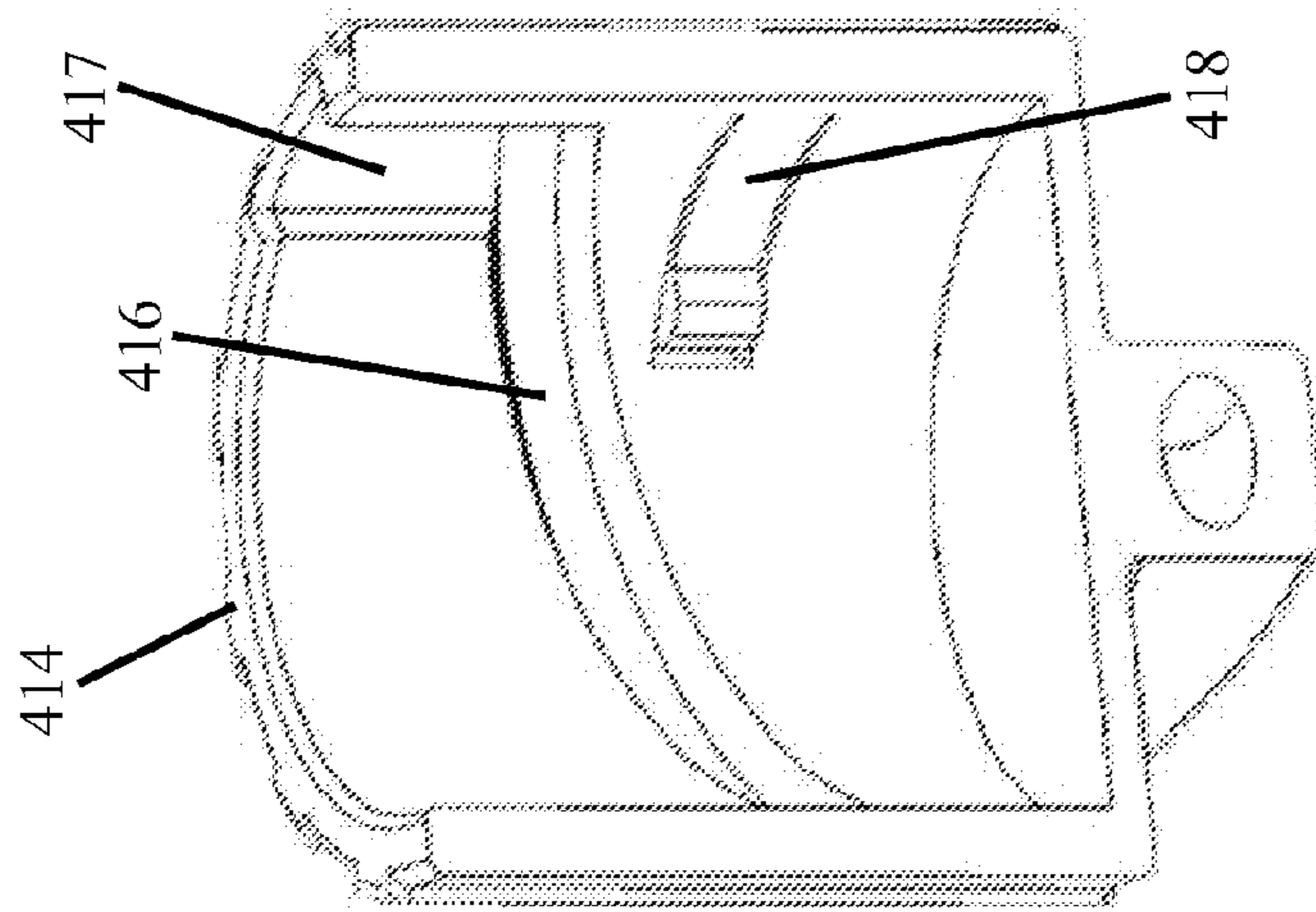

Fig. 11B

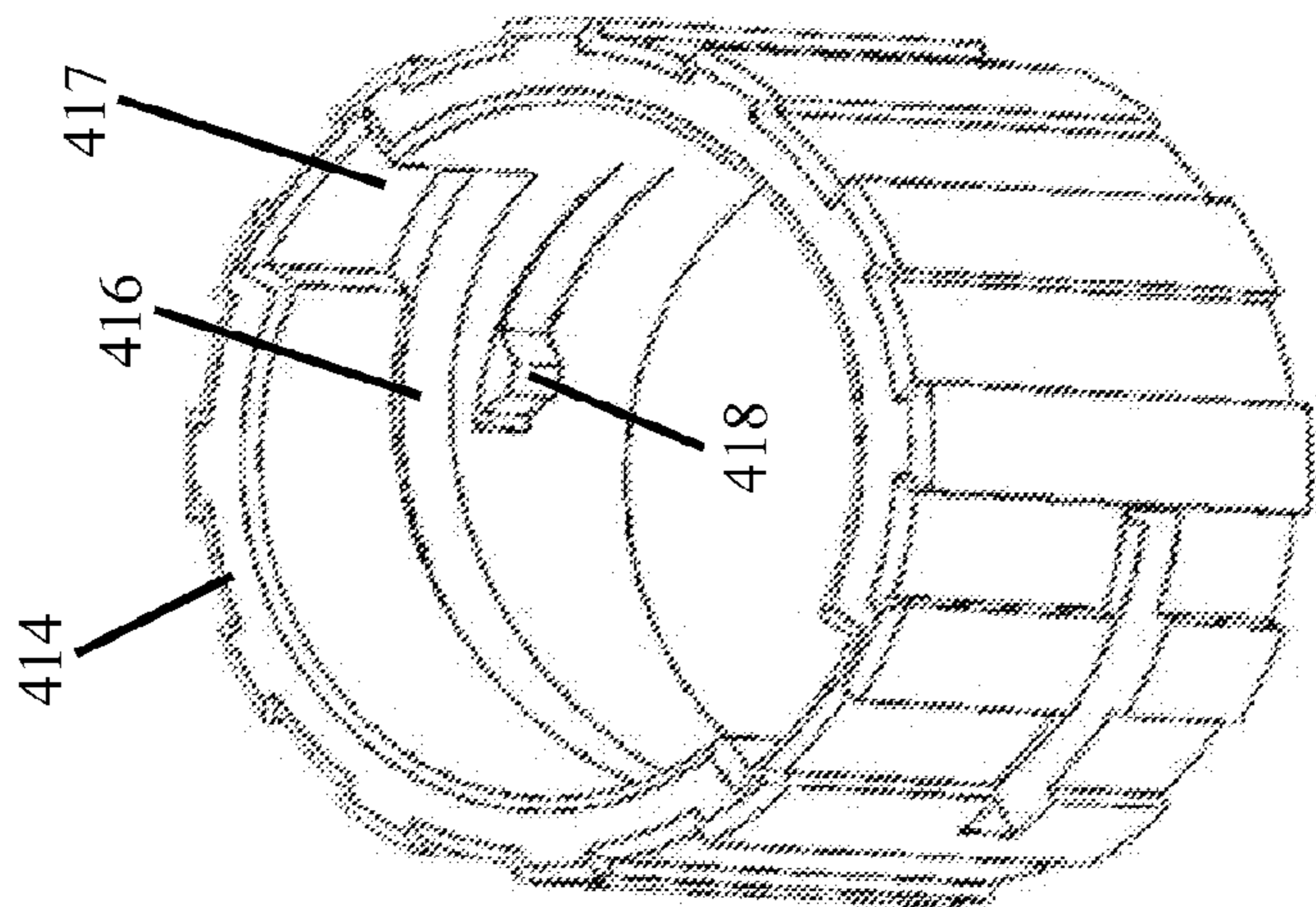

Fig. 11A

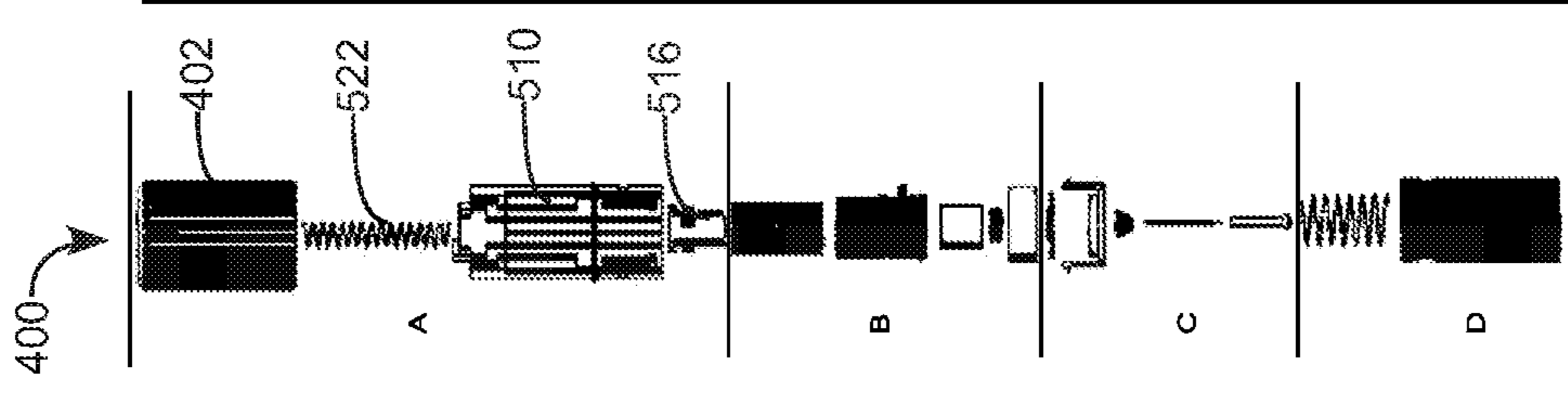

FIG. 12A

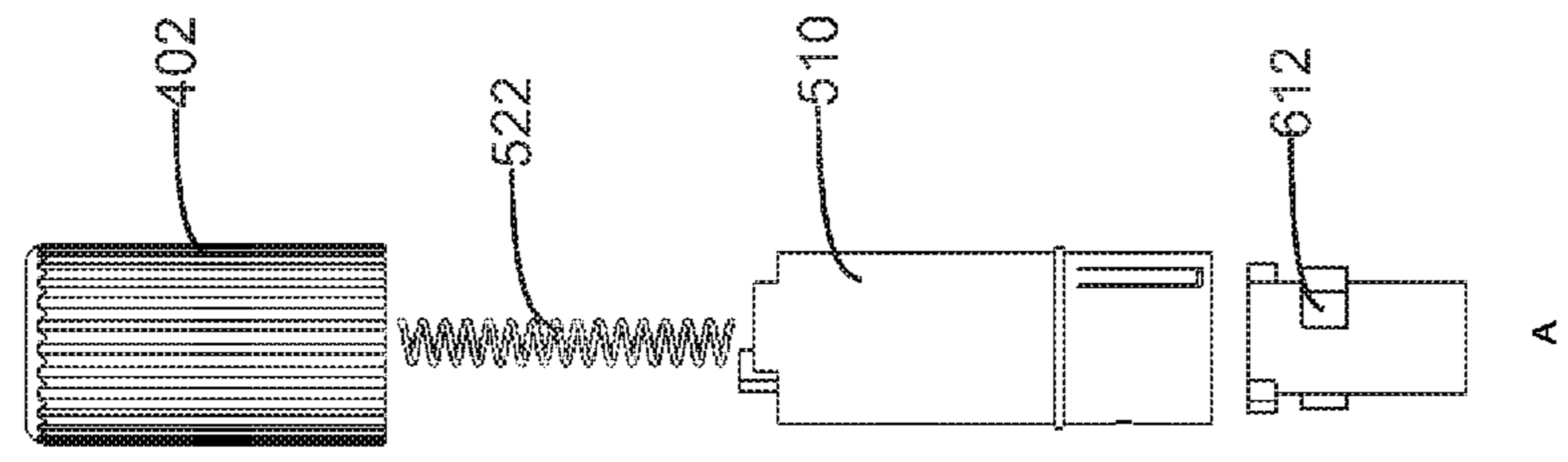

FIG. 12B

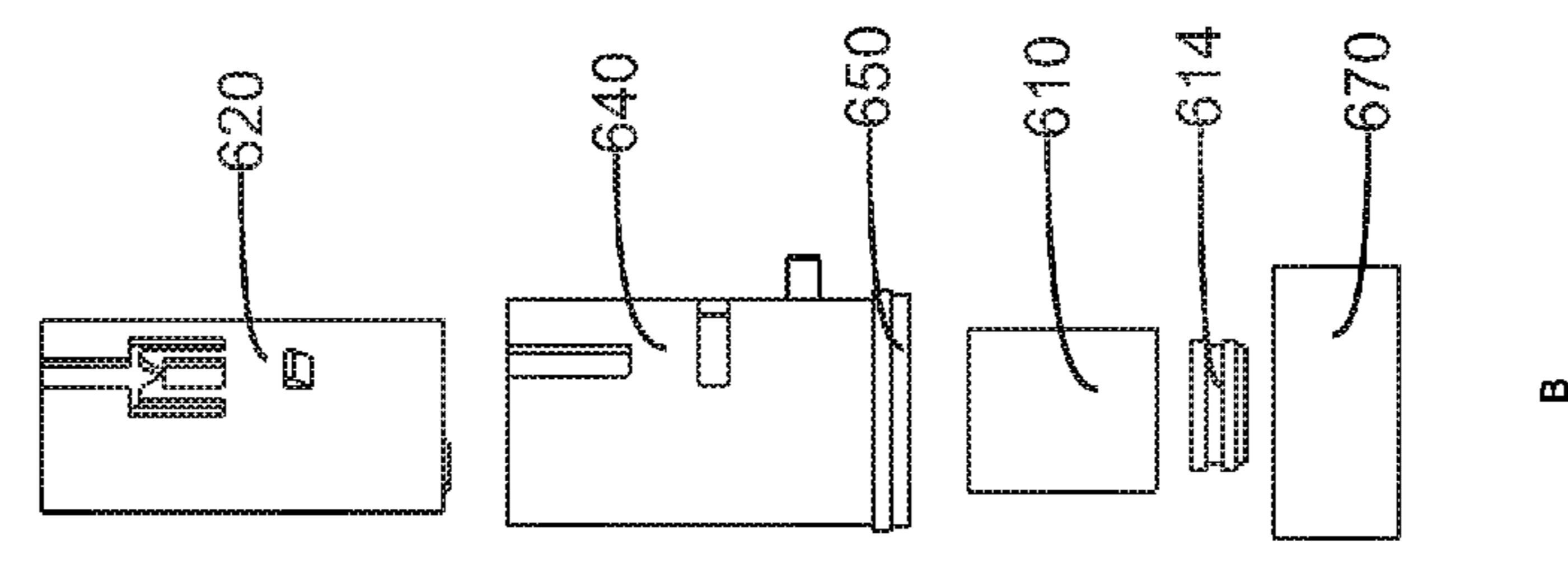

FIG. 12C

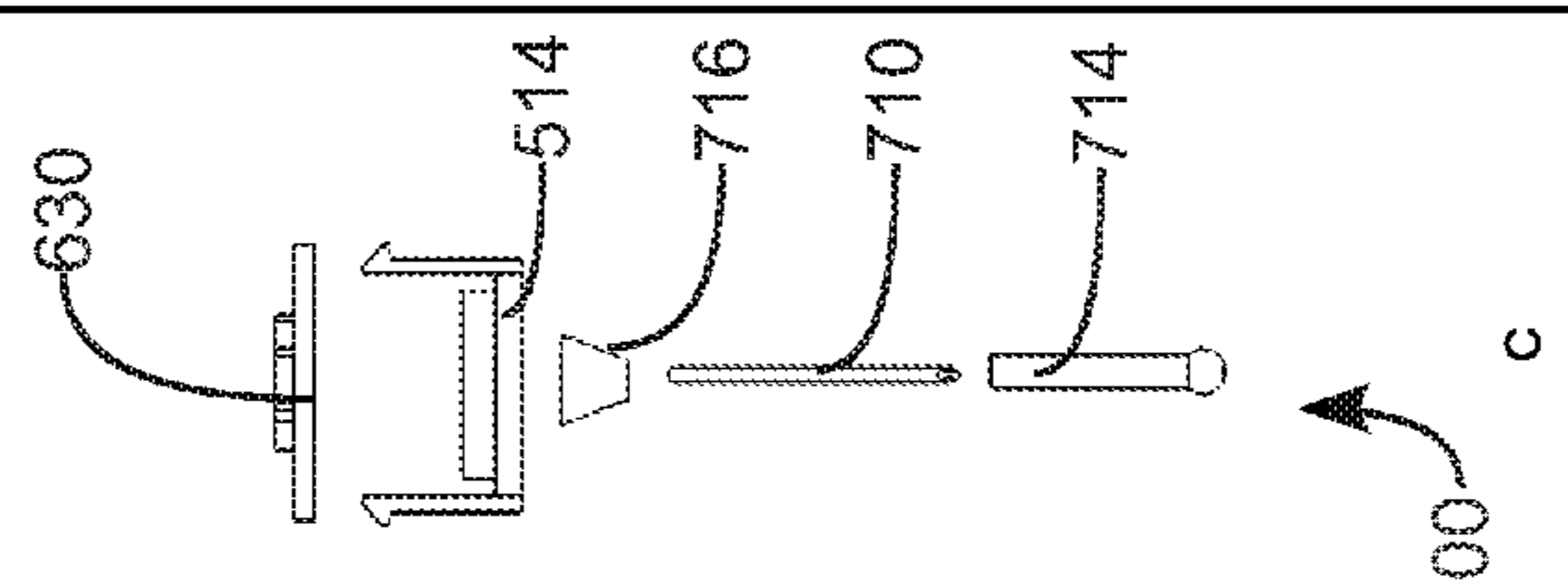

FIG. 12D

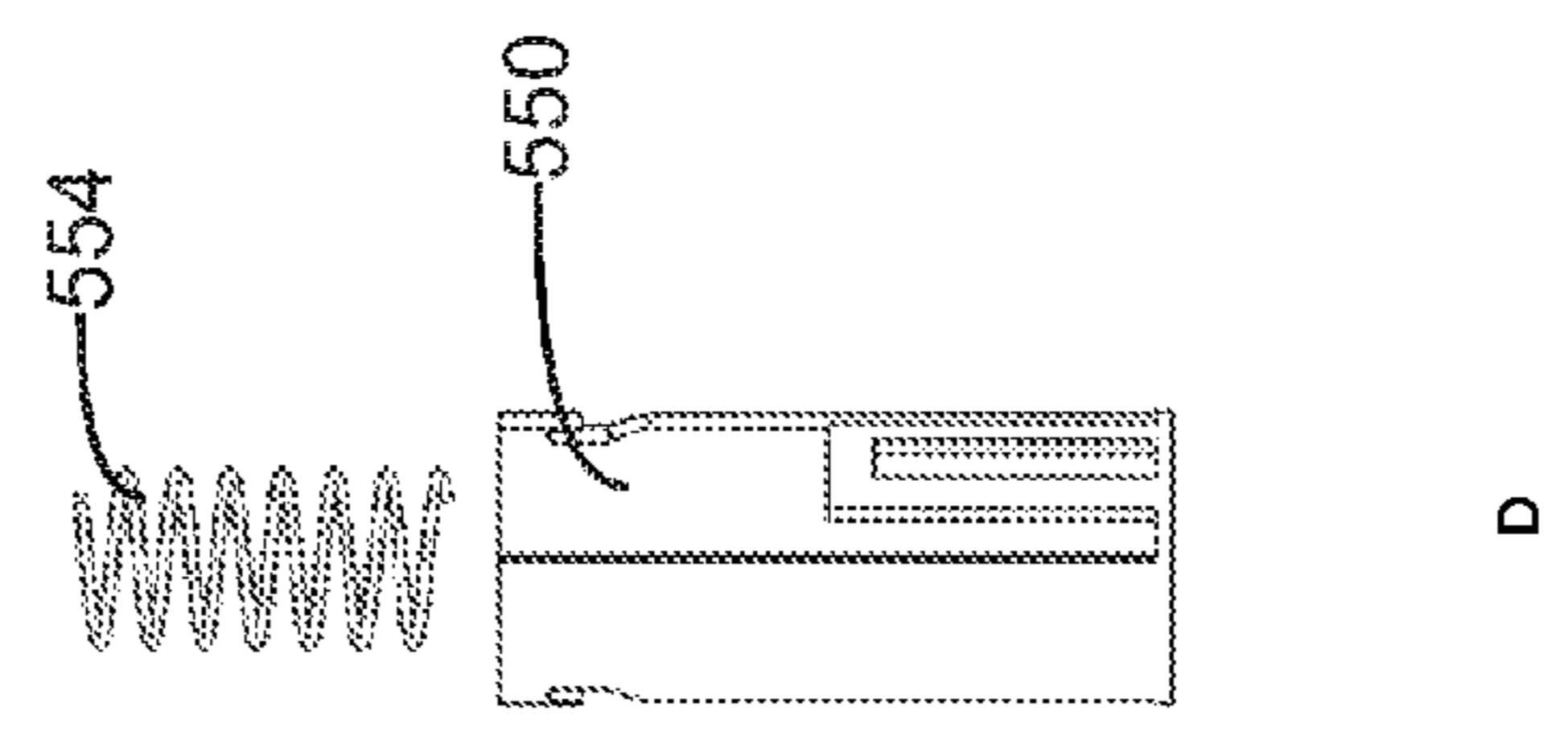

FIG. 12E

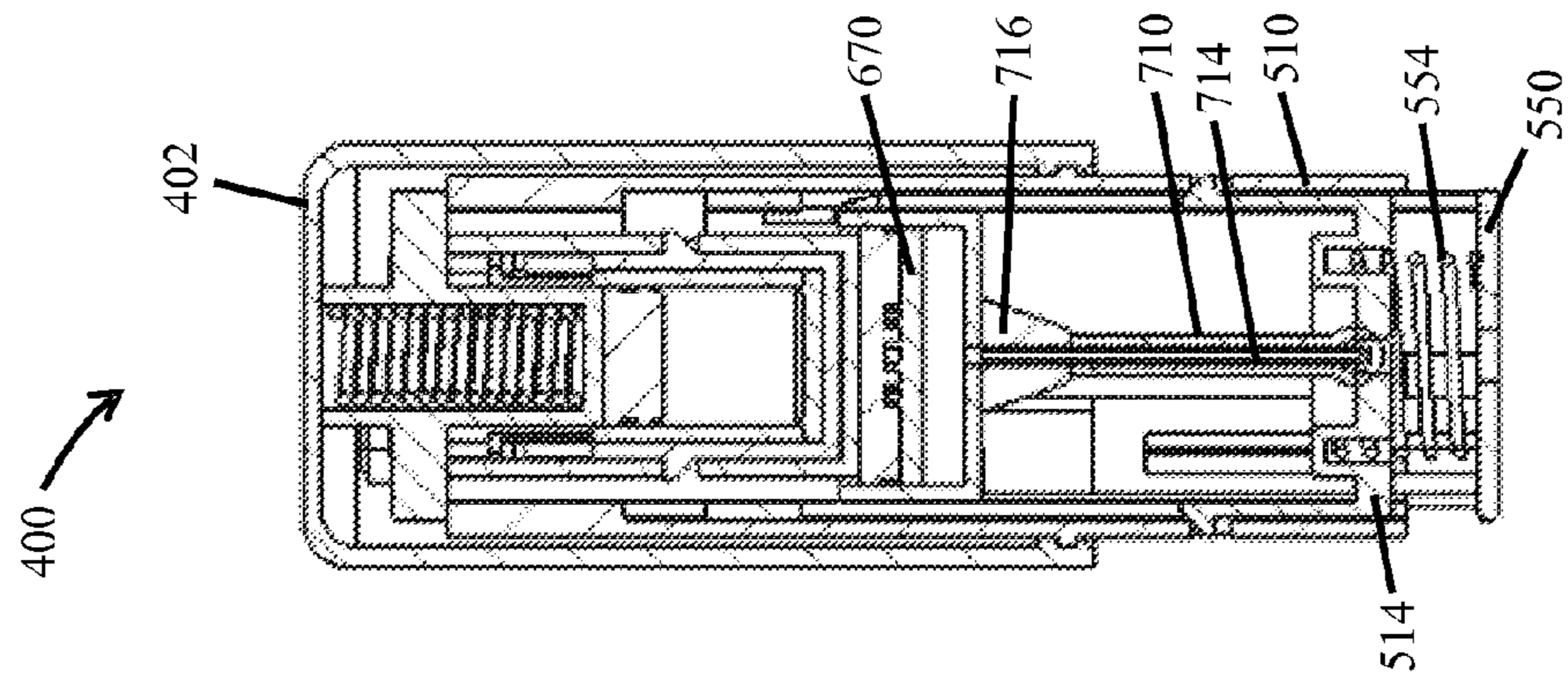

Fig. 13A

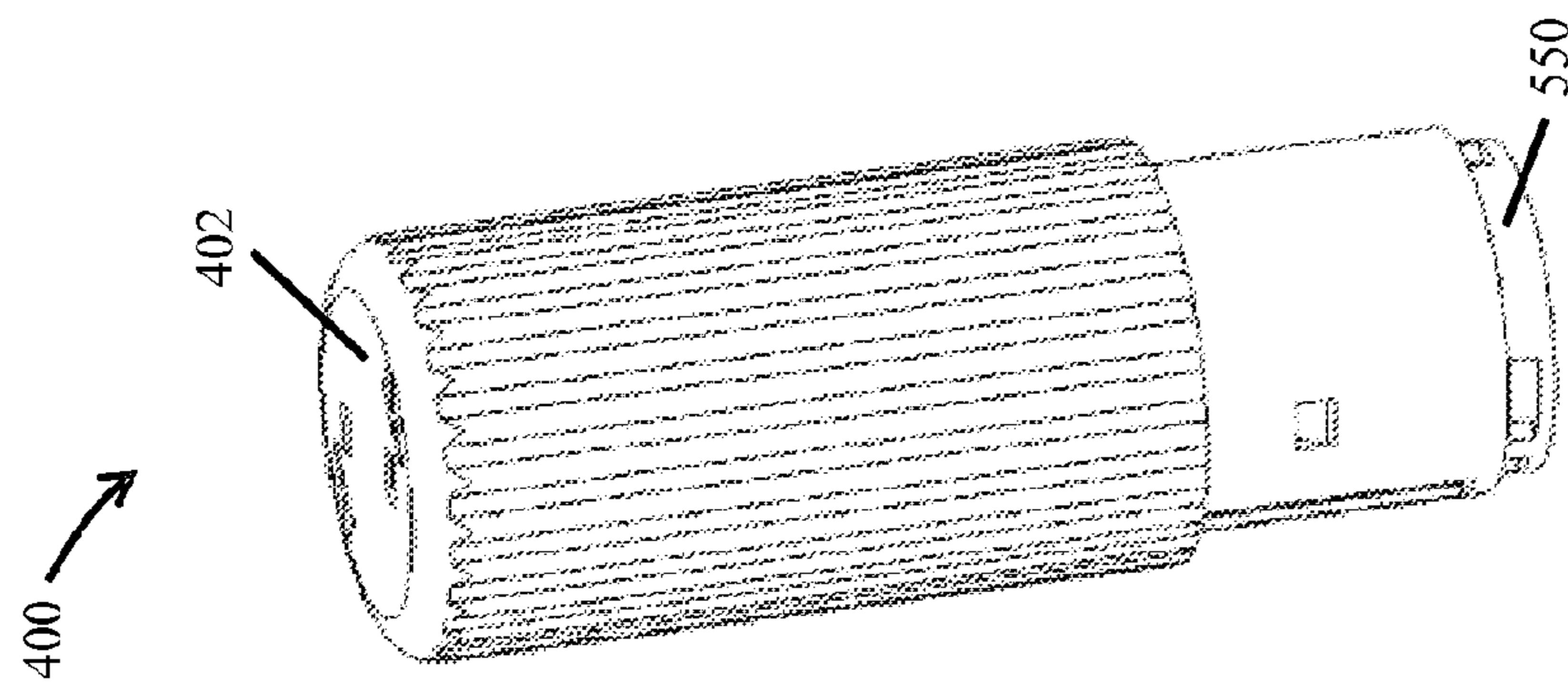

Fig. 13B



Fig. 13C

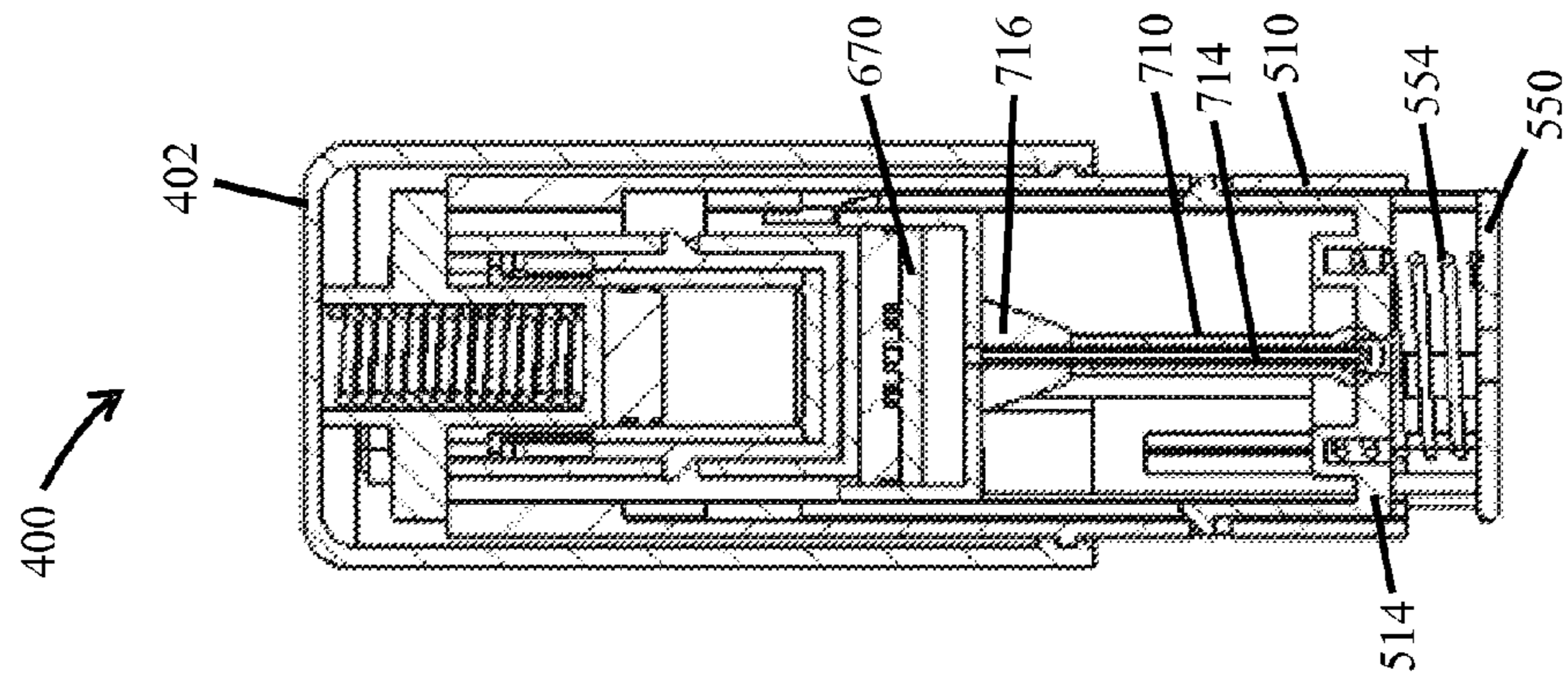

Fig. 13D

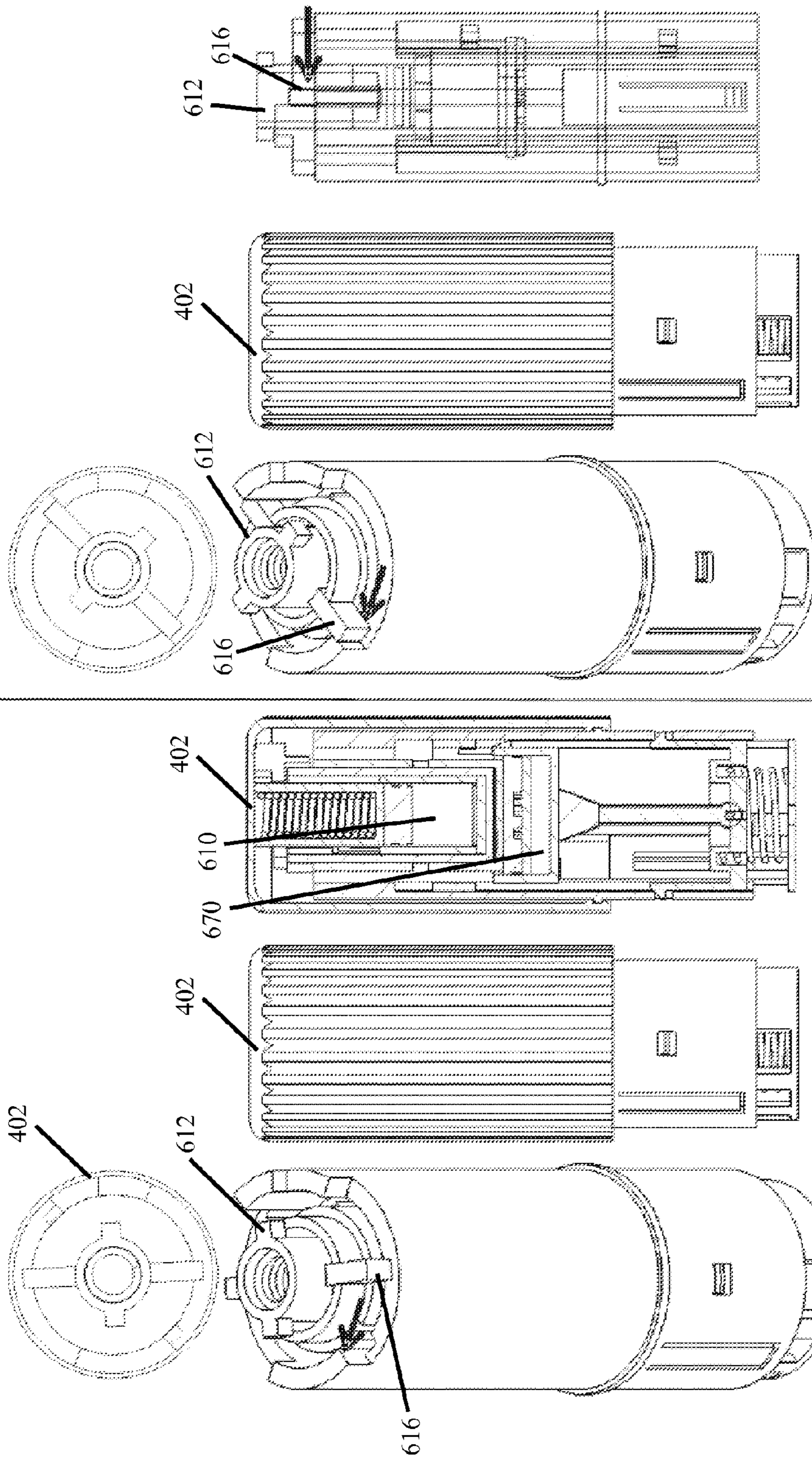

Fig. 15C

Fig. 15B

Fig. 15A

Fig. 14C

Fig. 14B

Fig. 14A

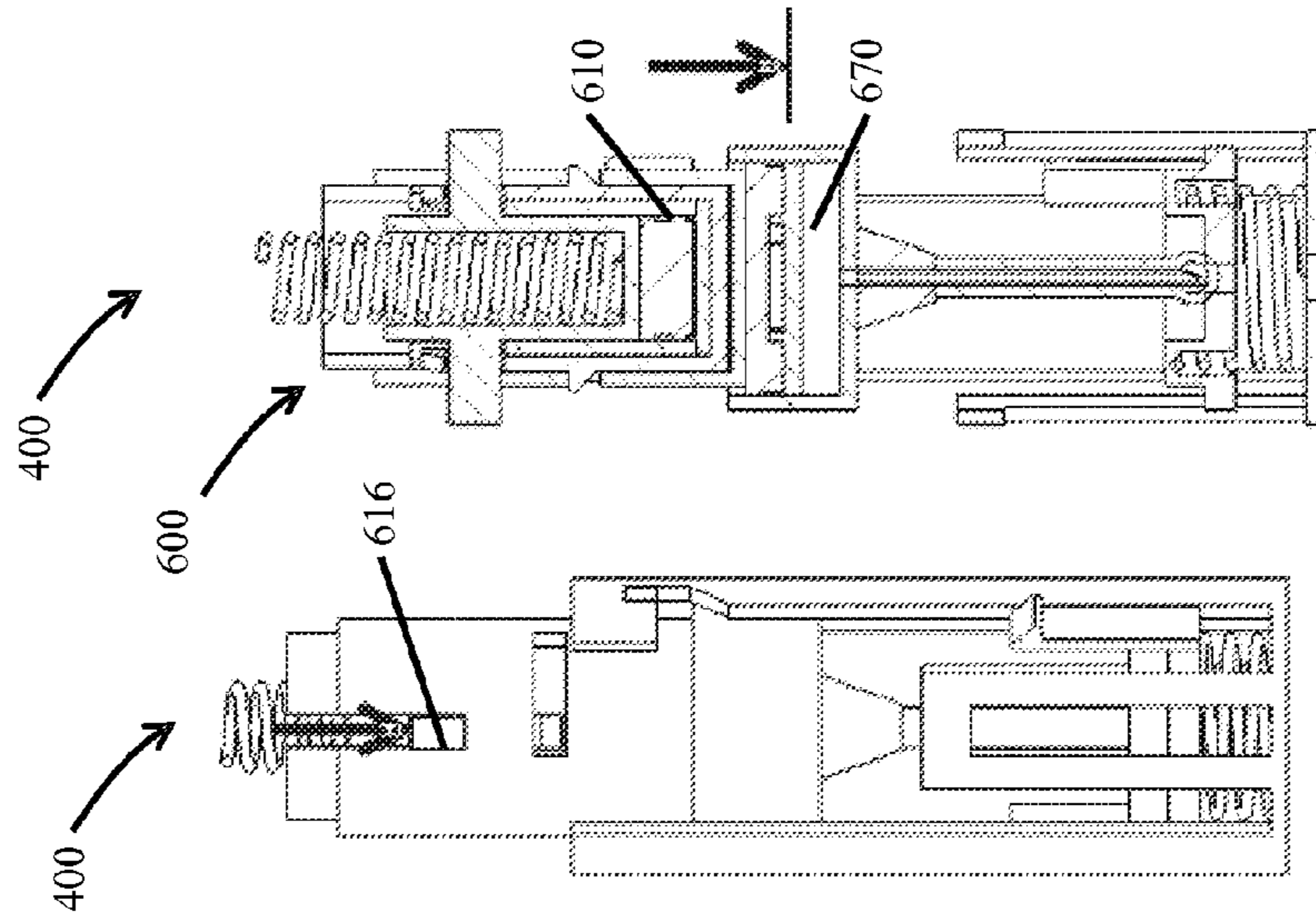

Fig. 17B

Fig. 17A

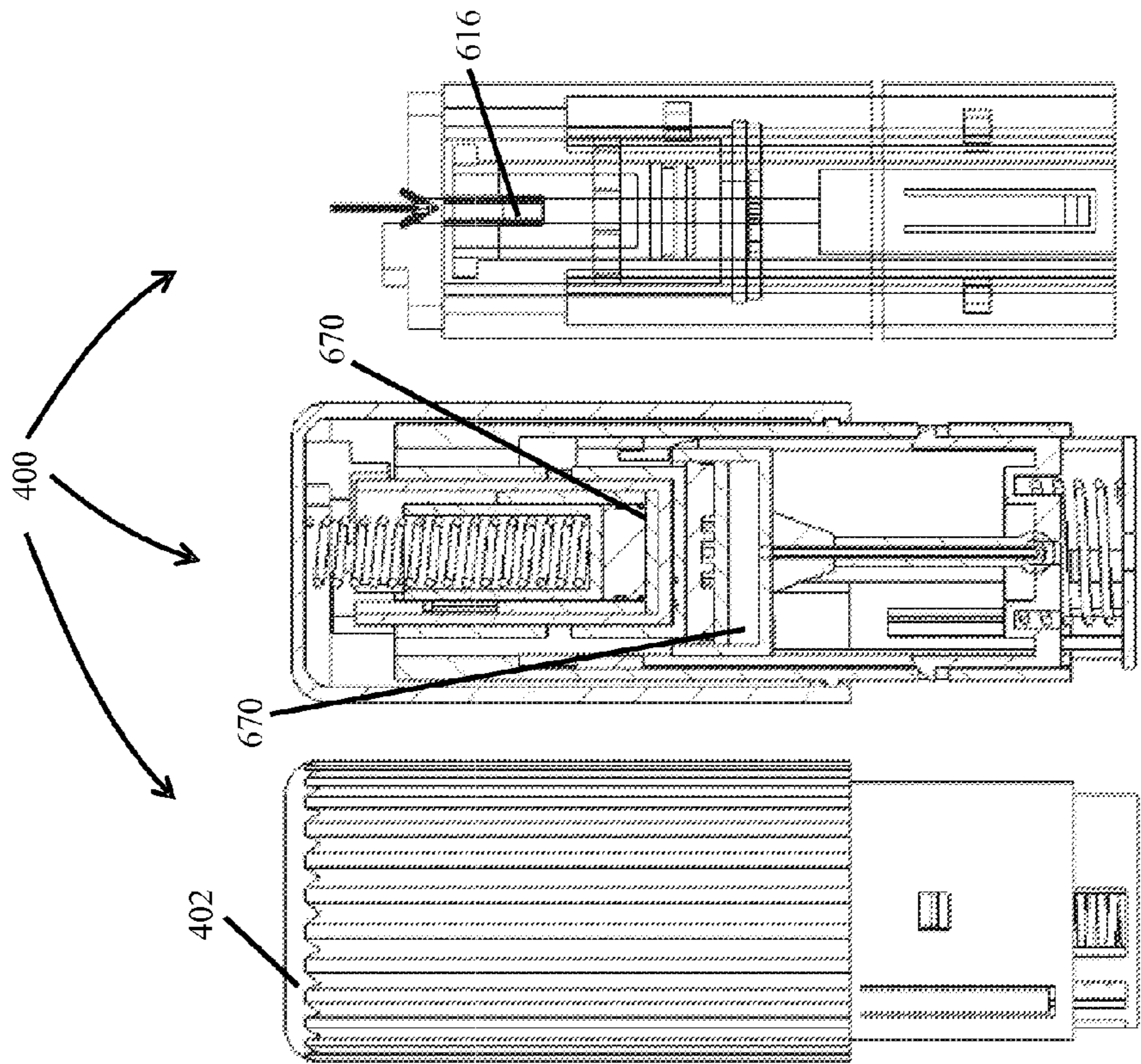

Fig. 16C

Fig. 16B

Fig. 16A

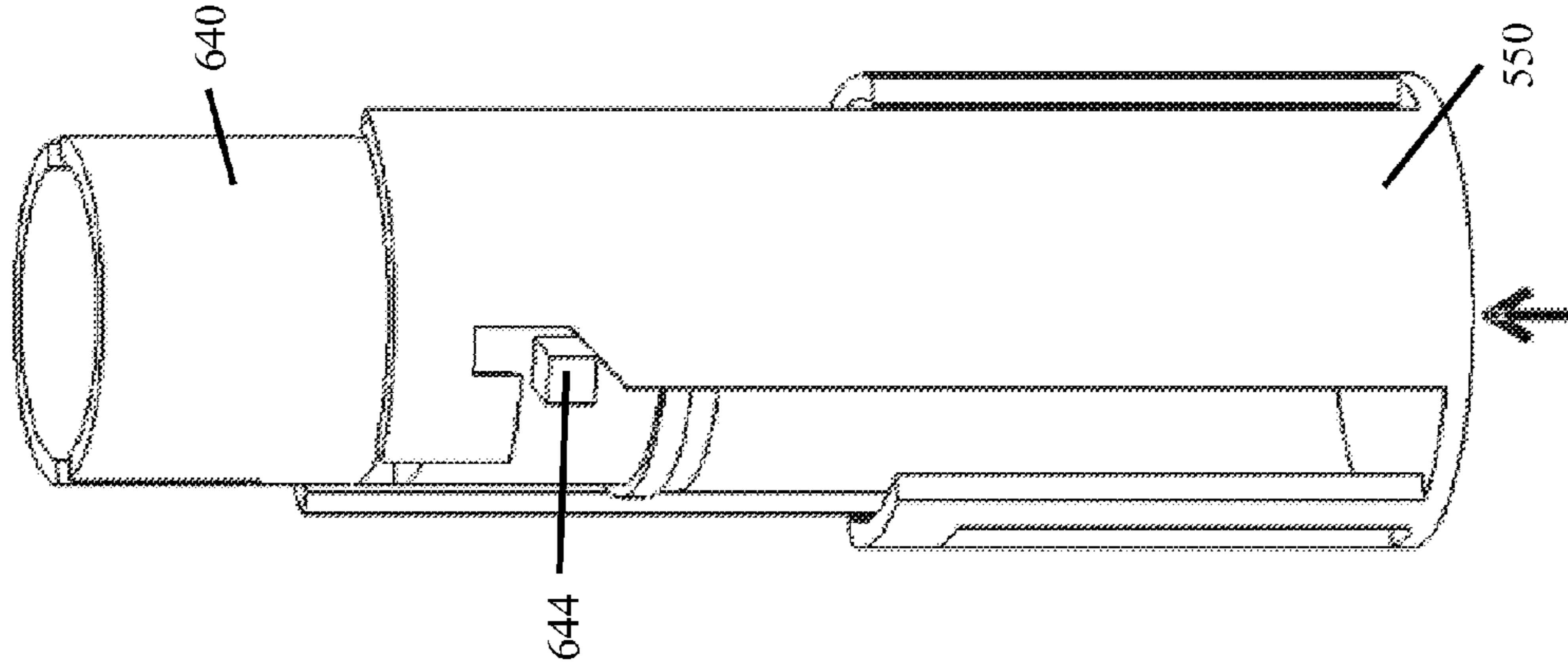

Fig. 18B

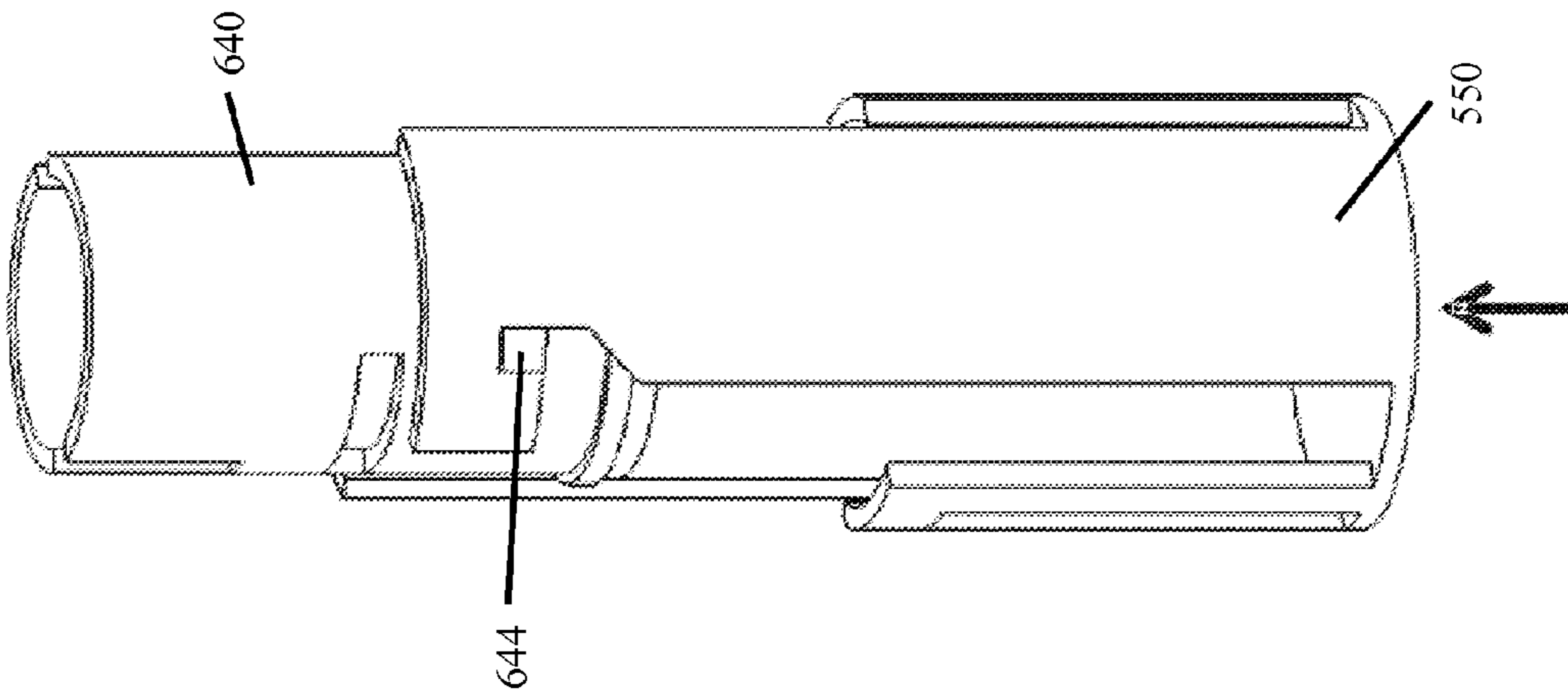

Fig. 18A

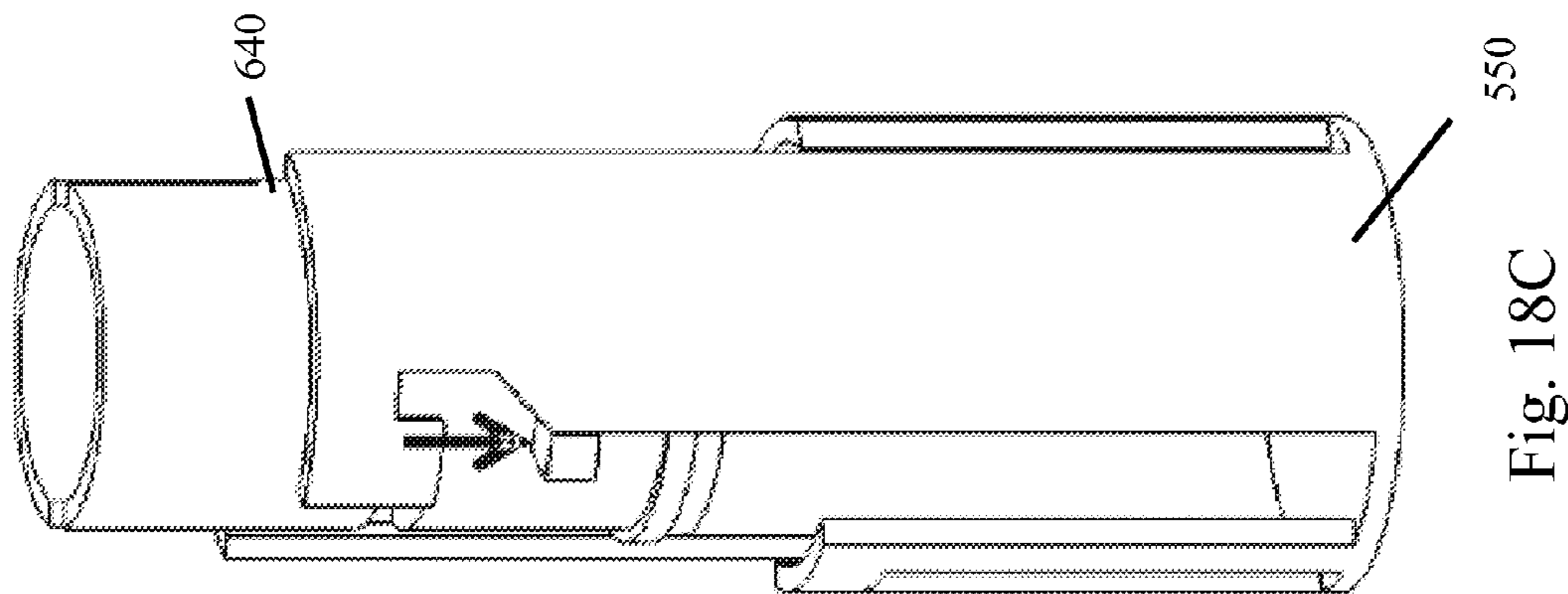

Fig. 18C

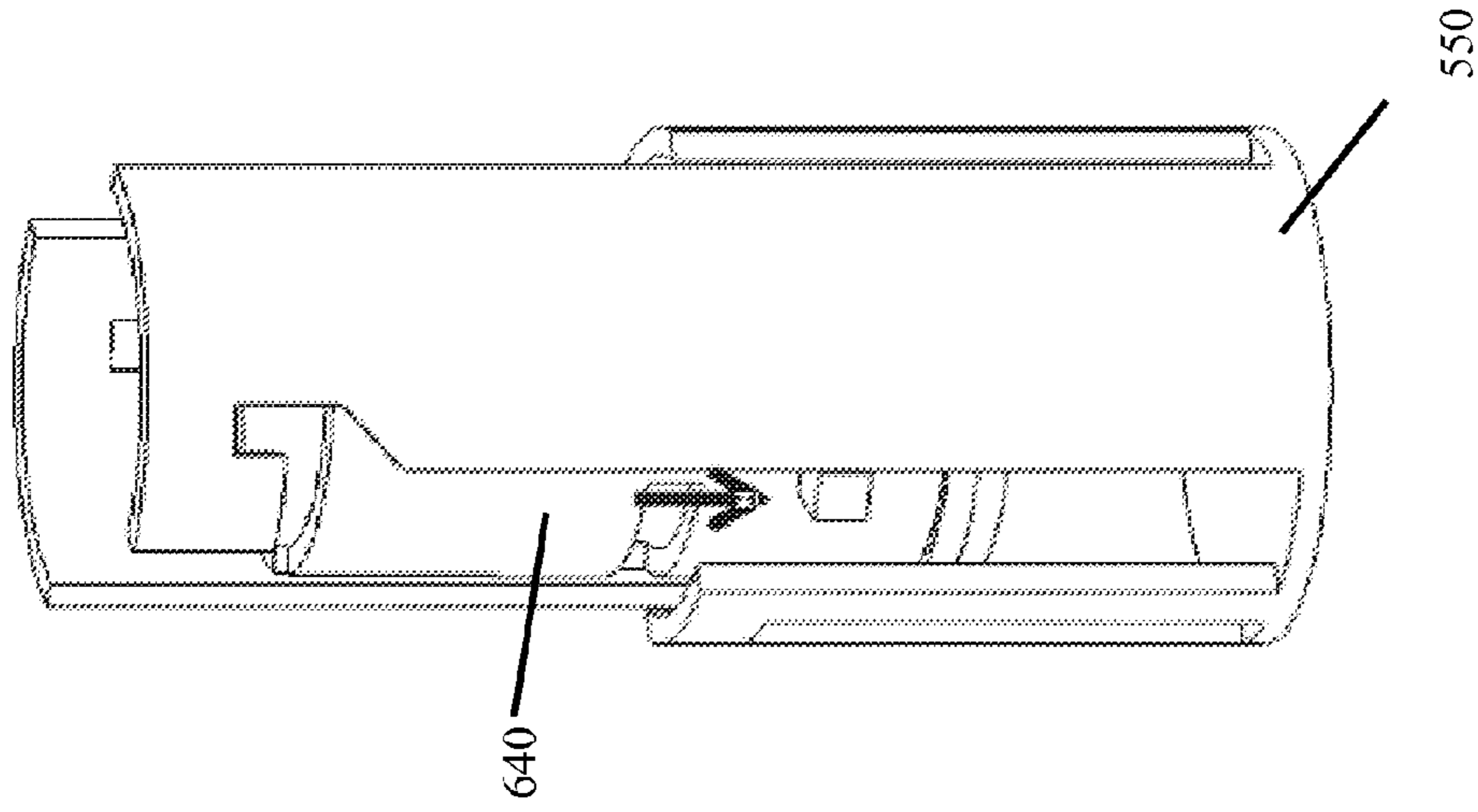

Fig. 18D



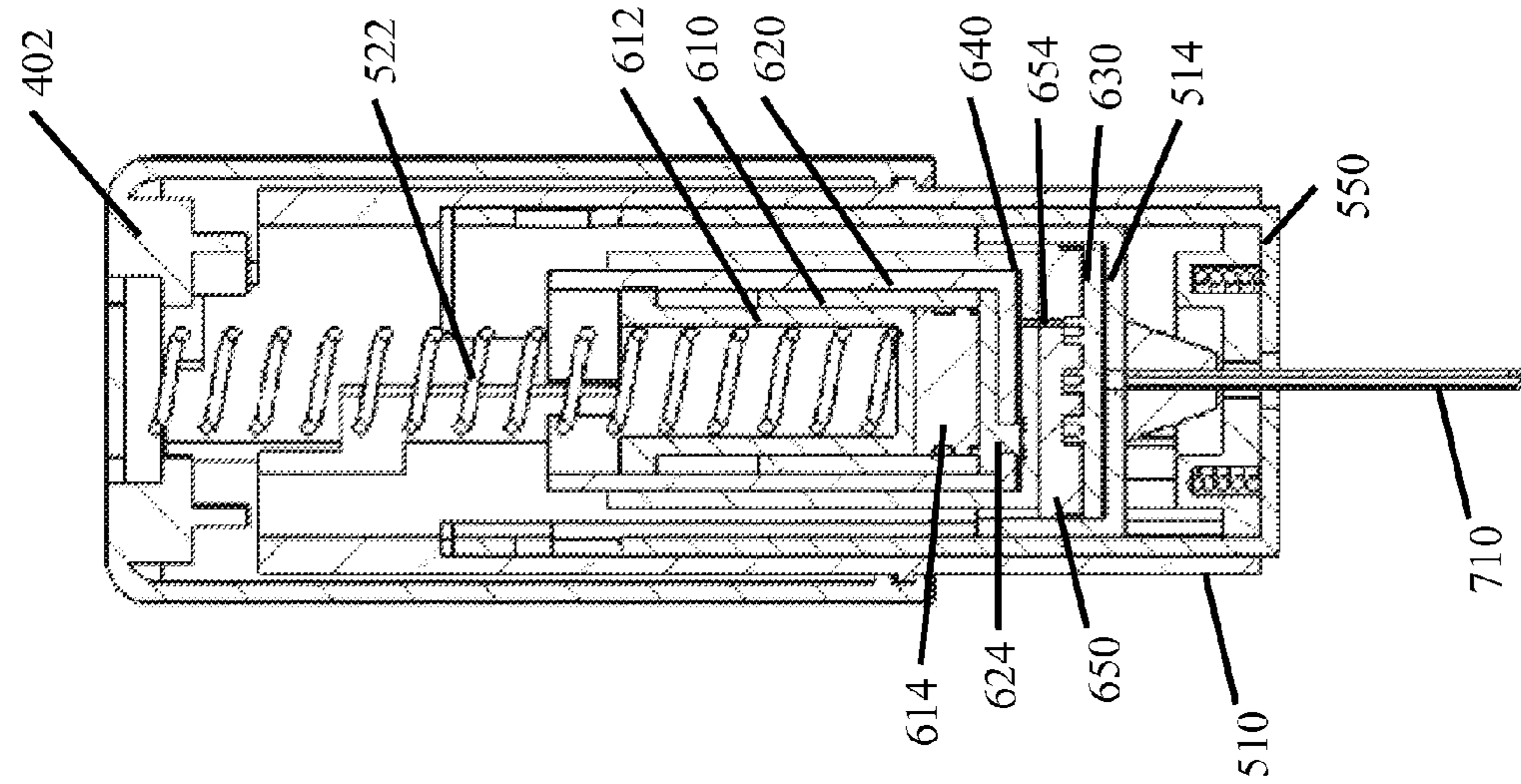

Fig. 19A

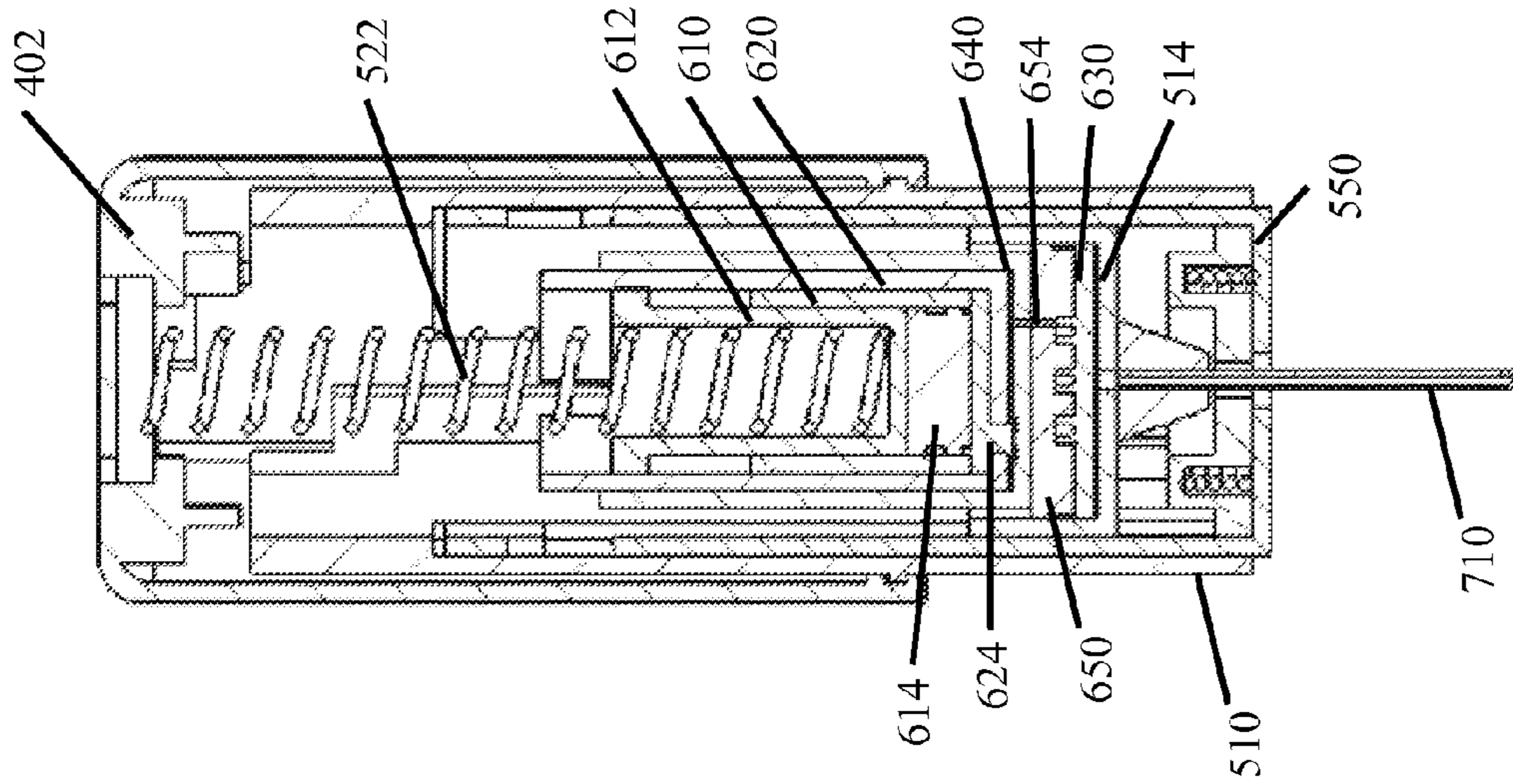

Fig. 19B

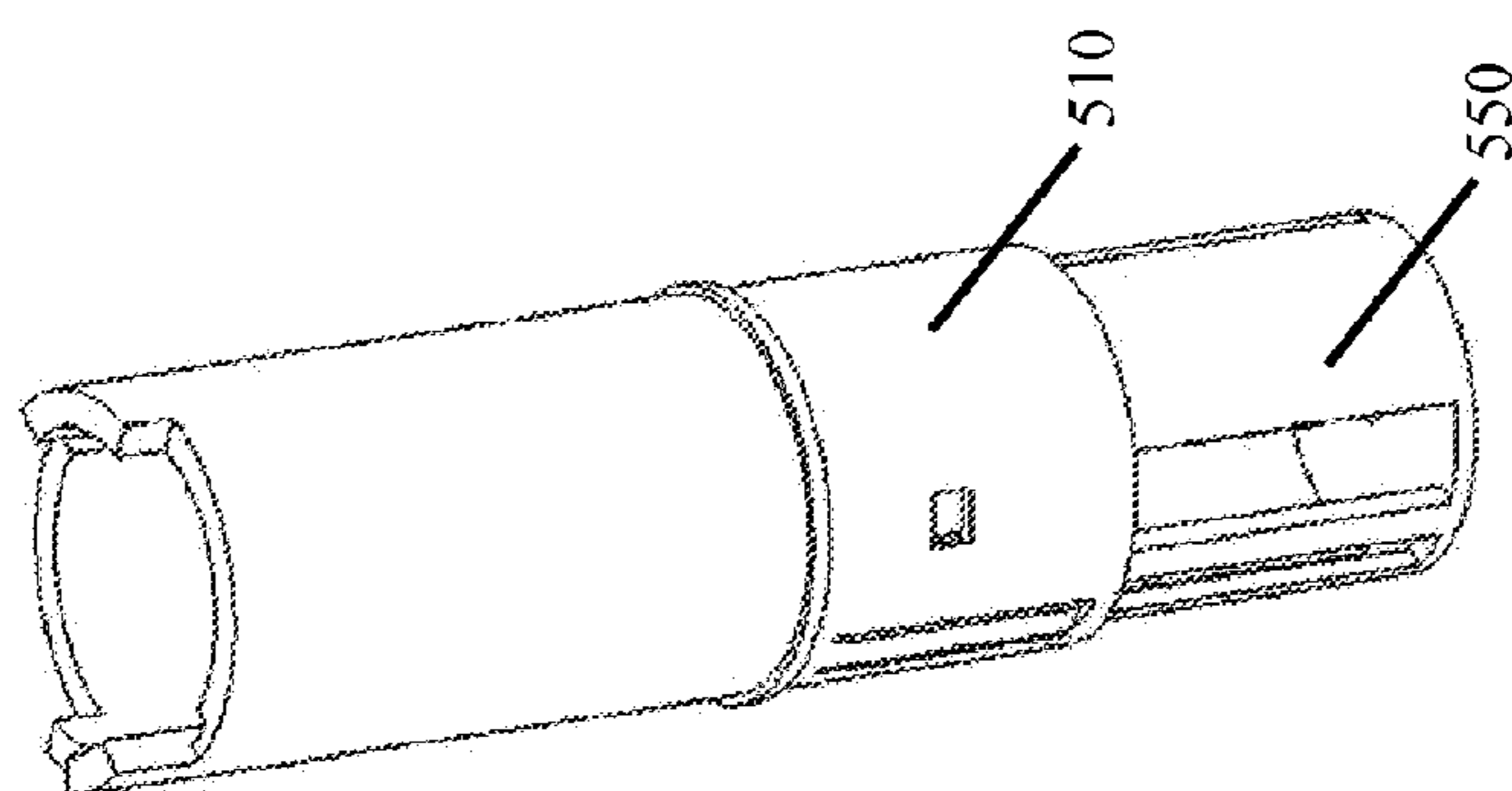

FIG. 20A

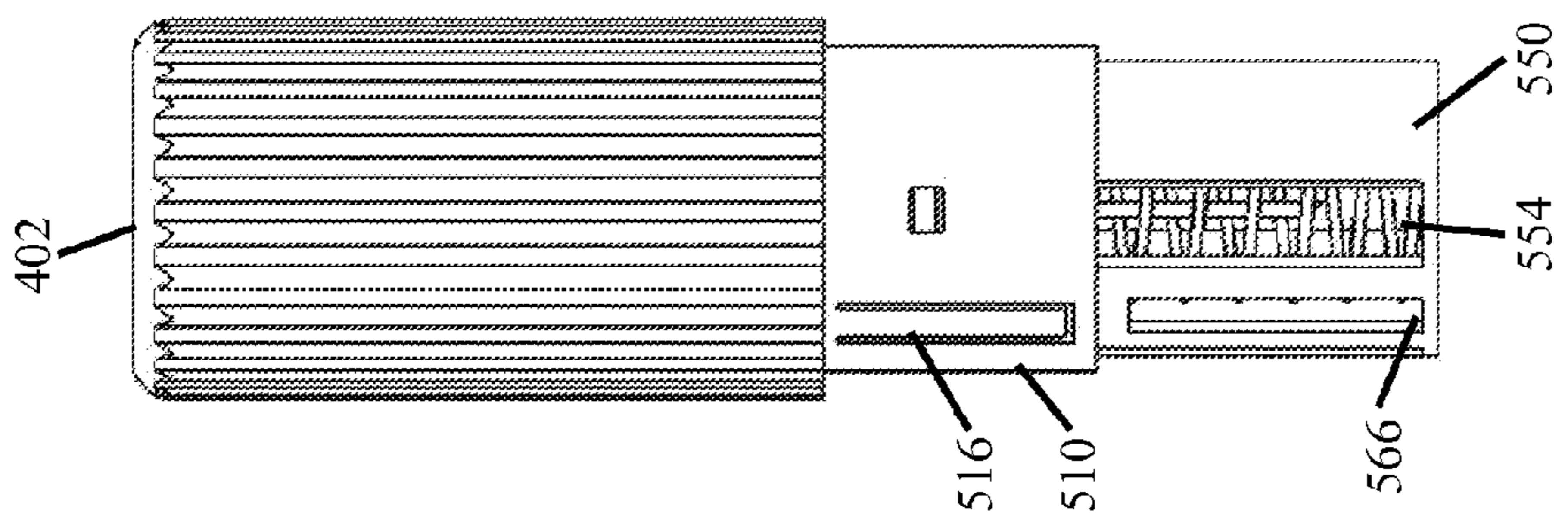

FIG. 20B

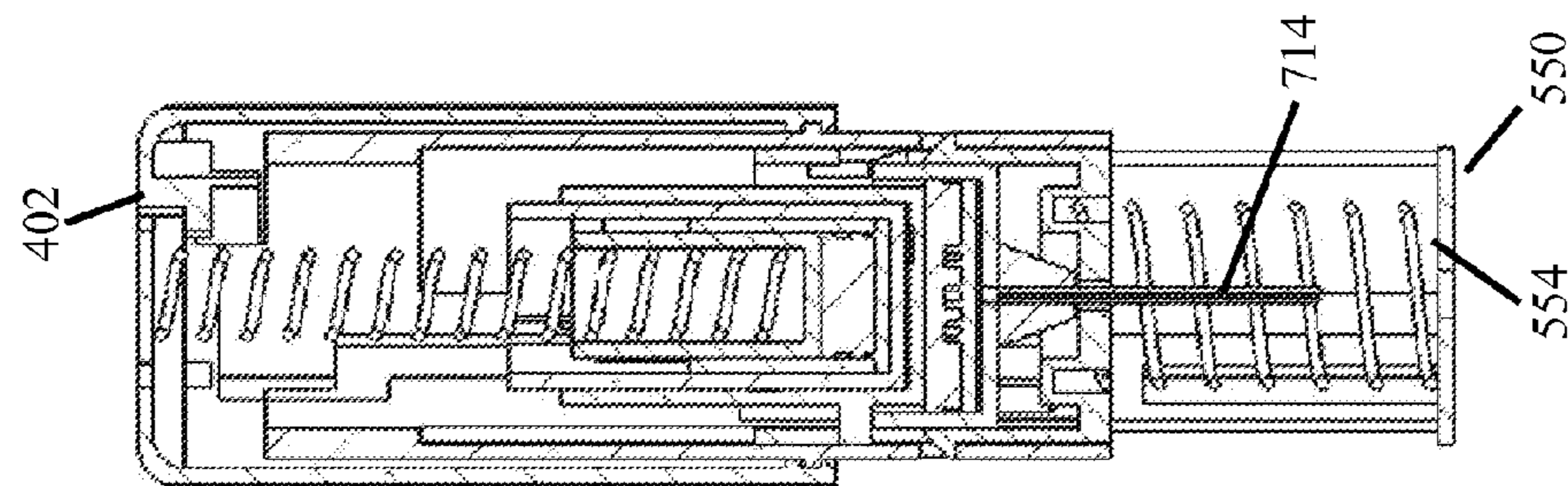

FIG. 20C

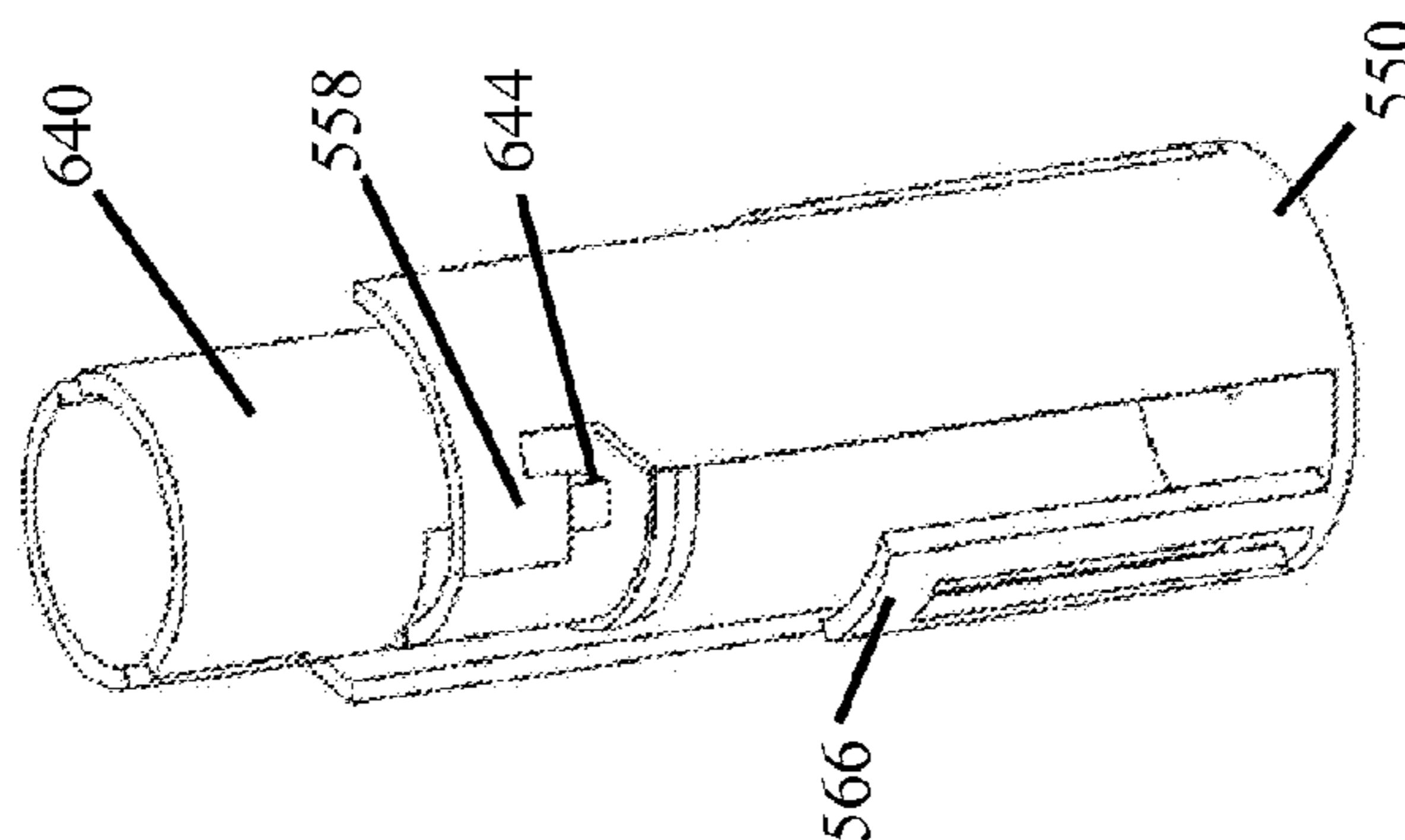

FIG. 20D

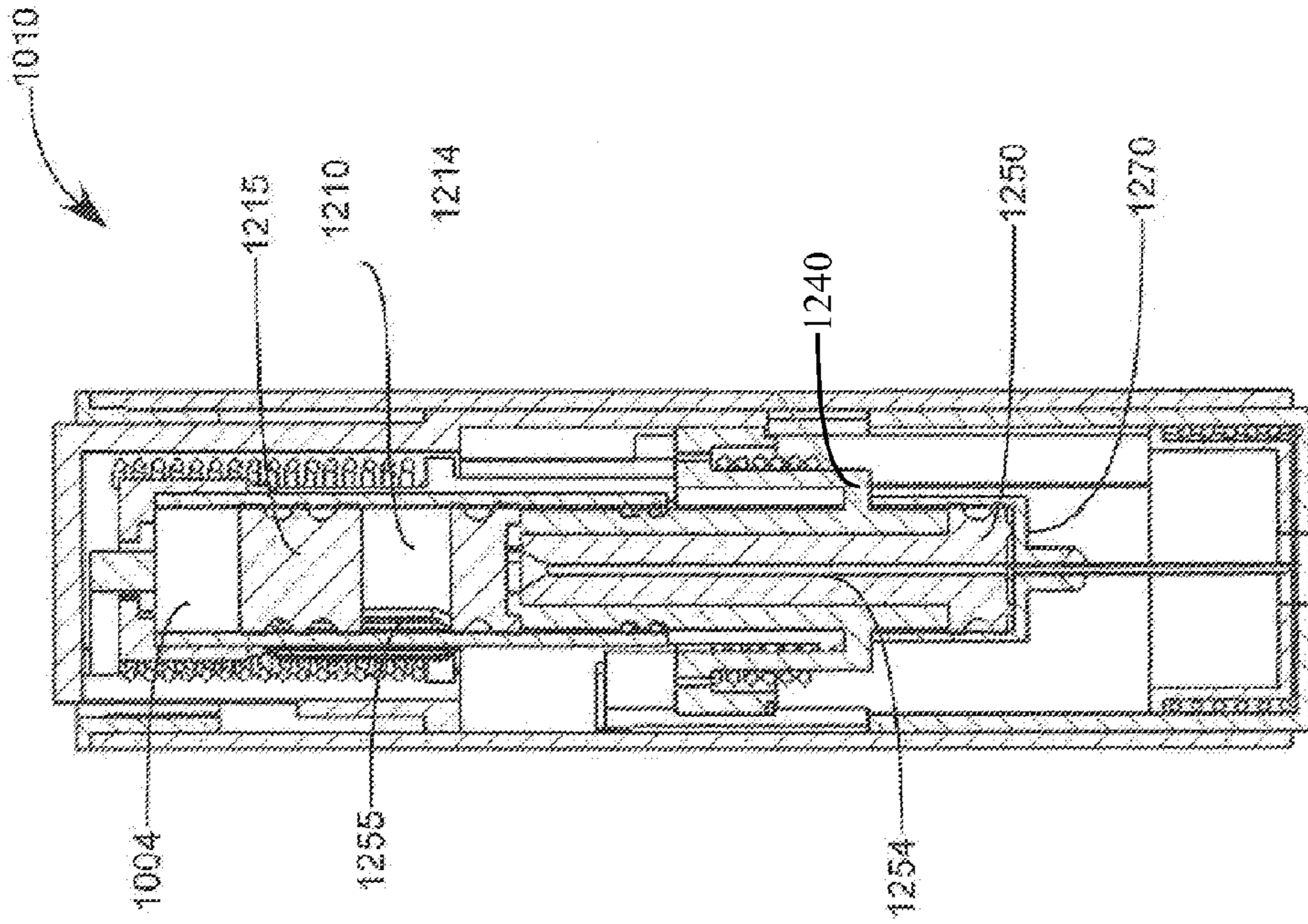

Fig. 21B

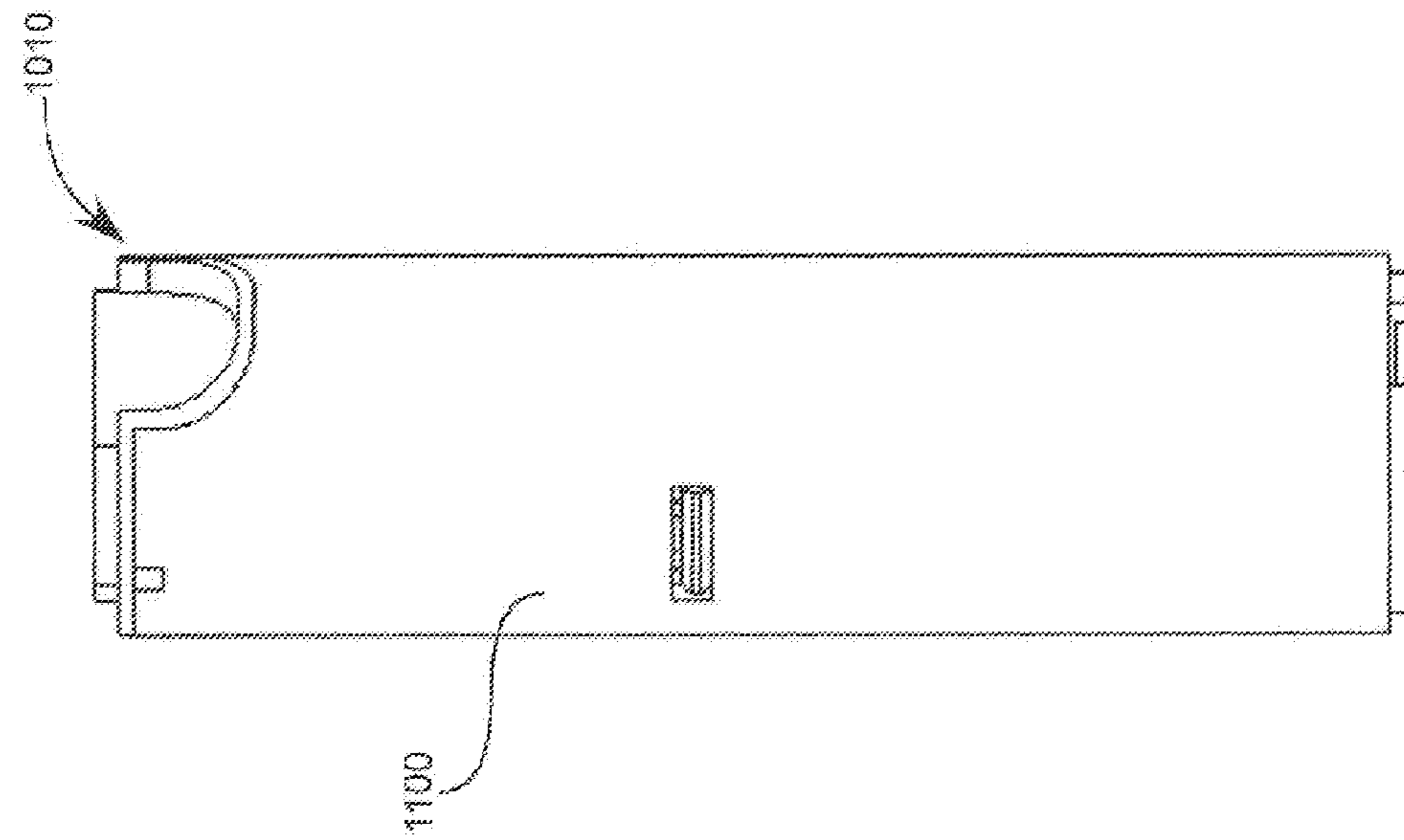

Fig. 21A

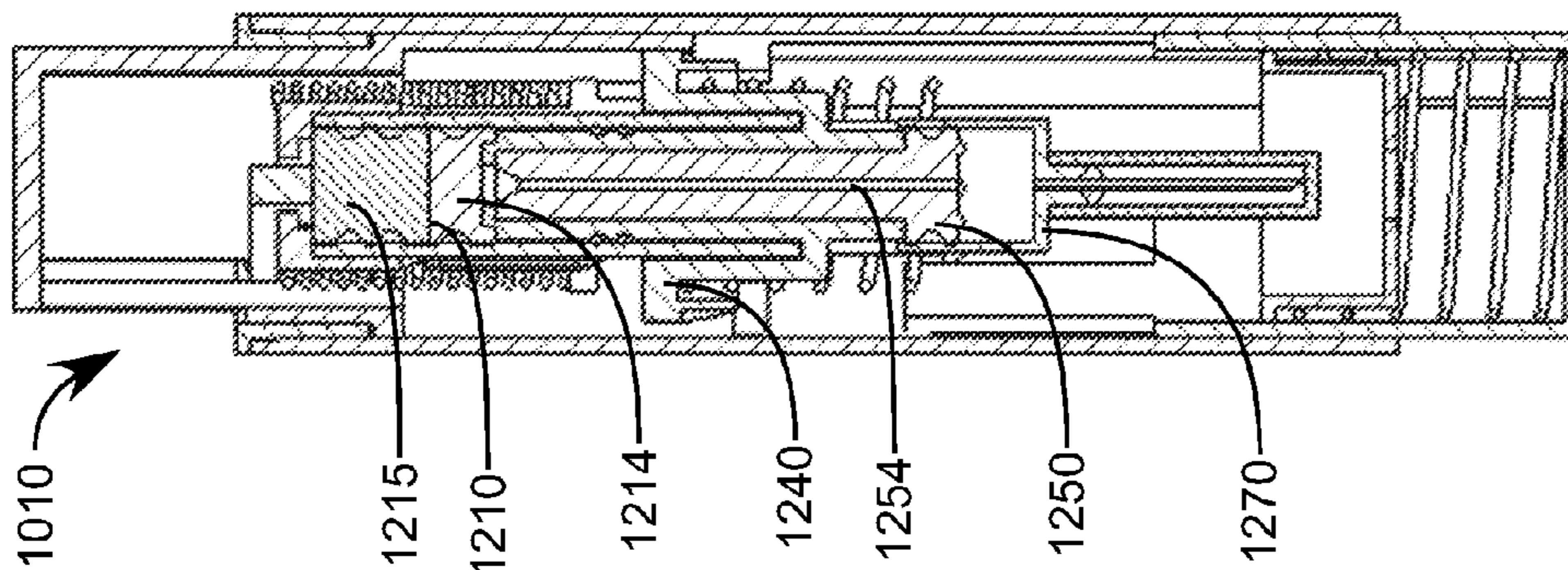

FIG. 22C

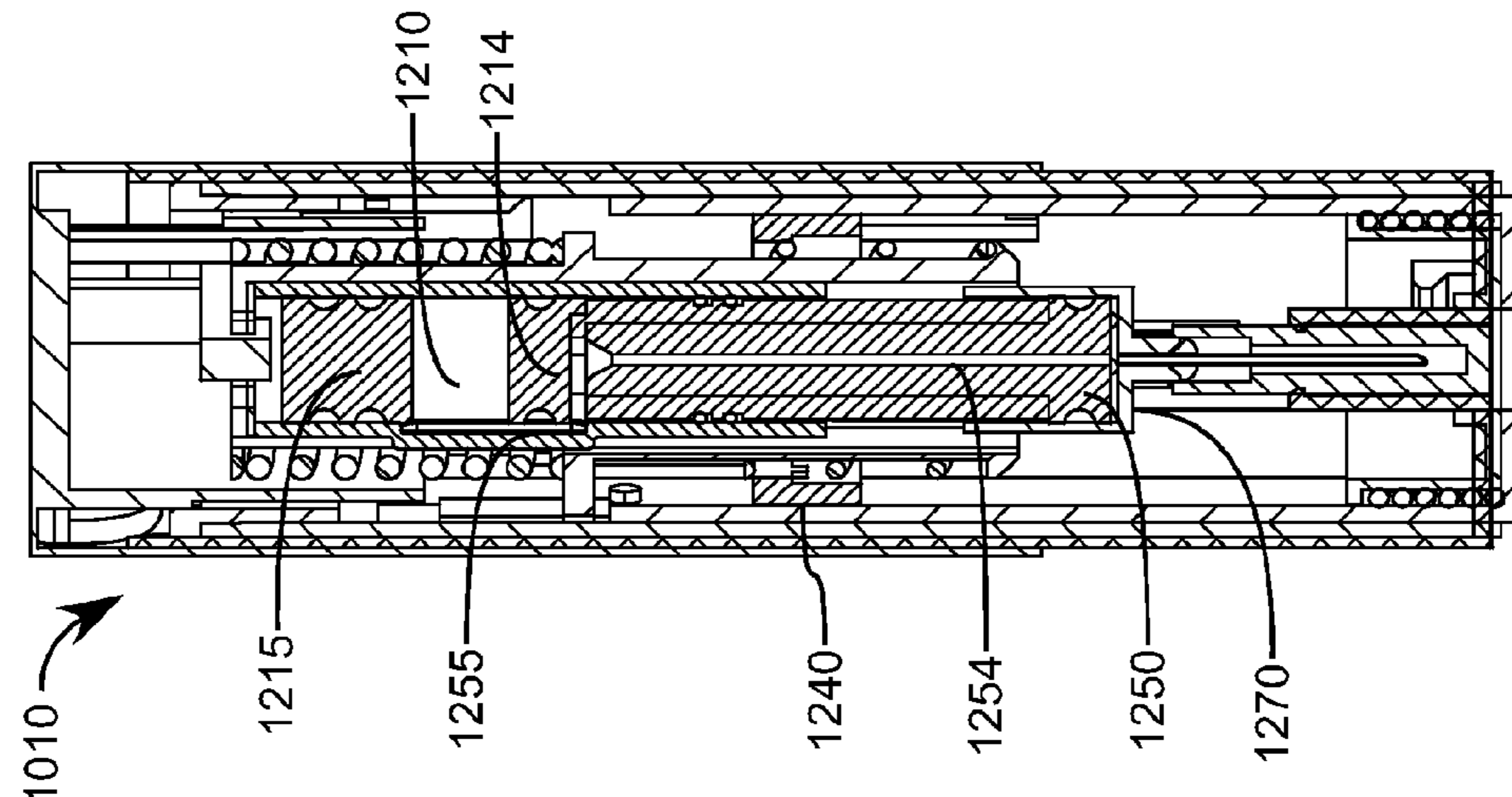

FIG. 22B

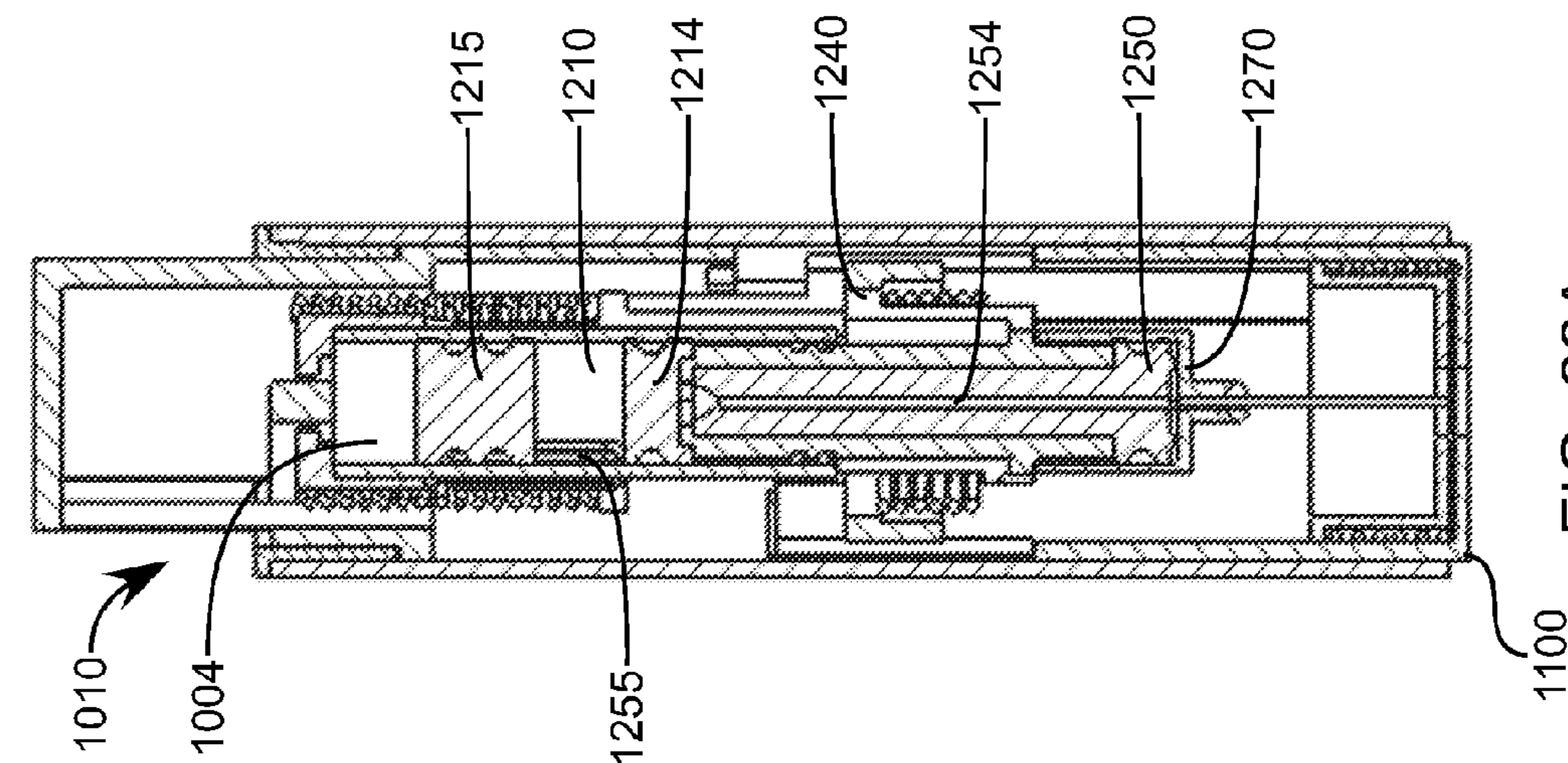

FIG. 22A

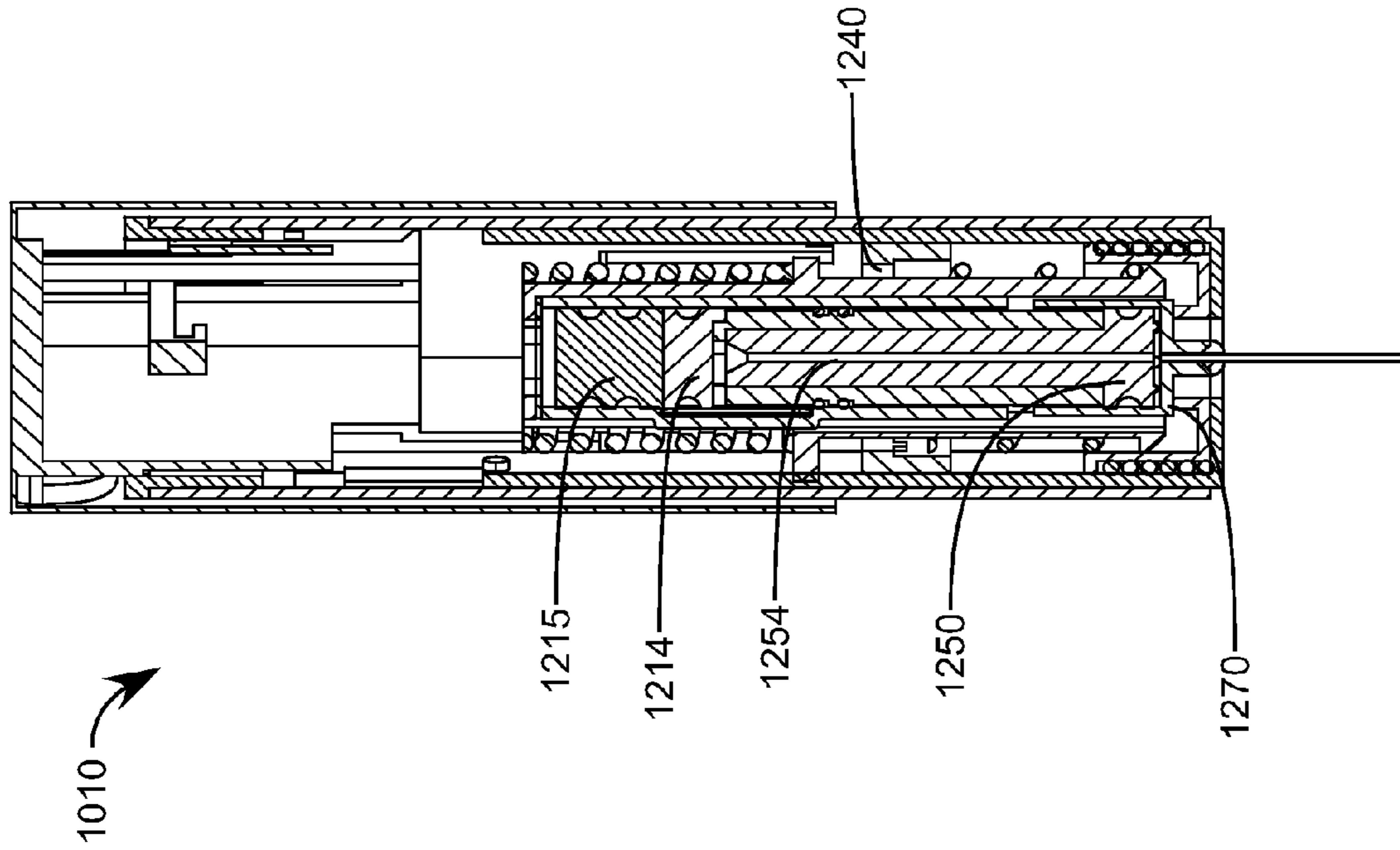

FIG. 22E

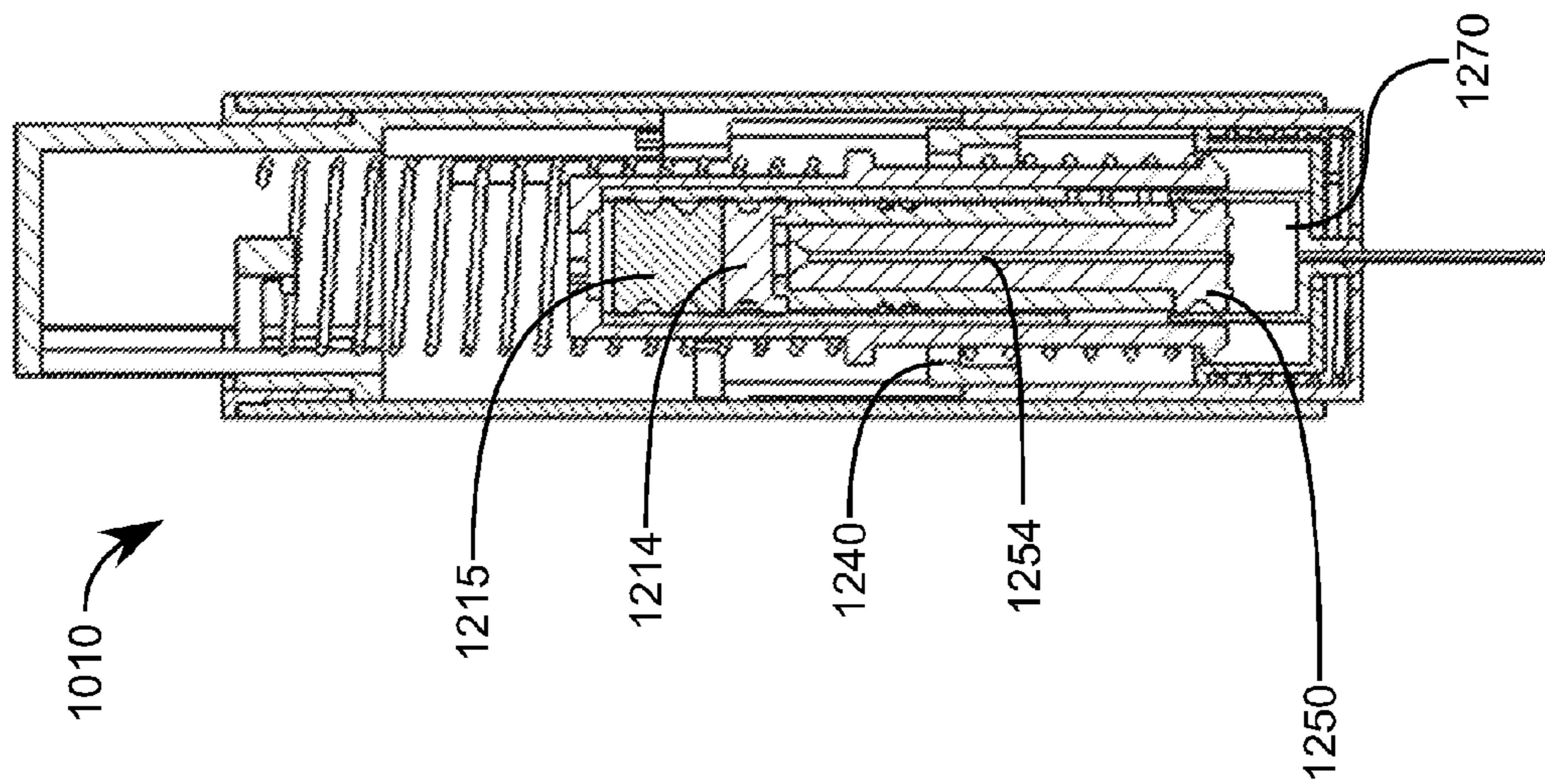

FIG. 22D

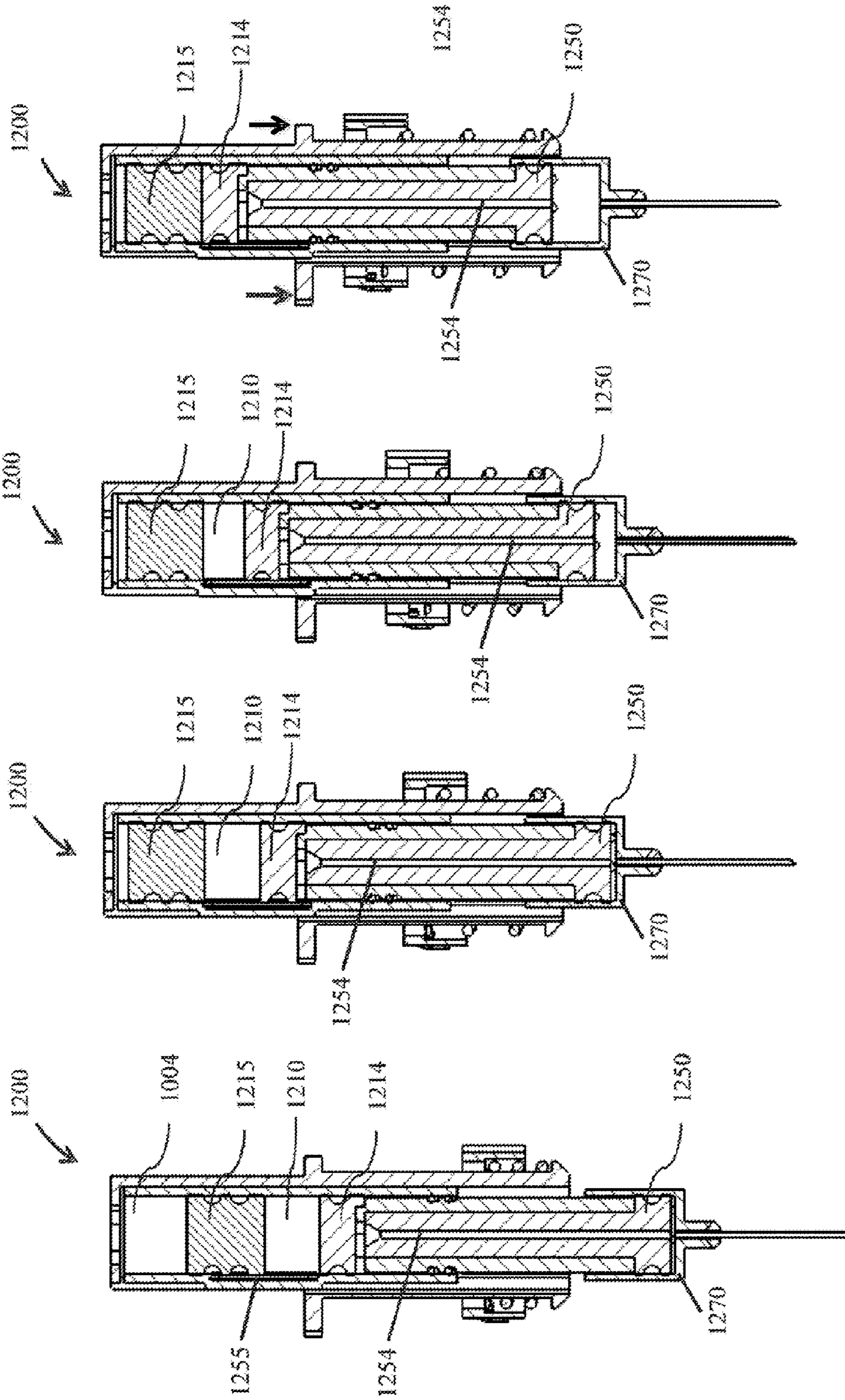

Fig. 23D

Fig. 23C

Fig. 23B

Fig. 23A

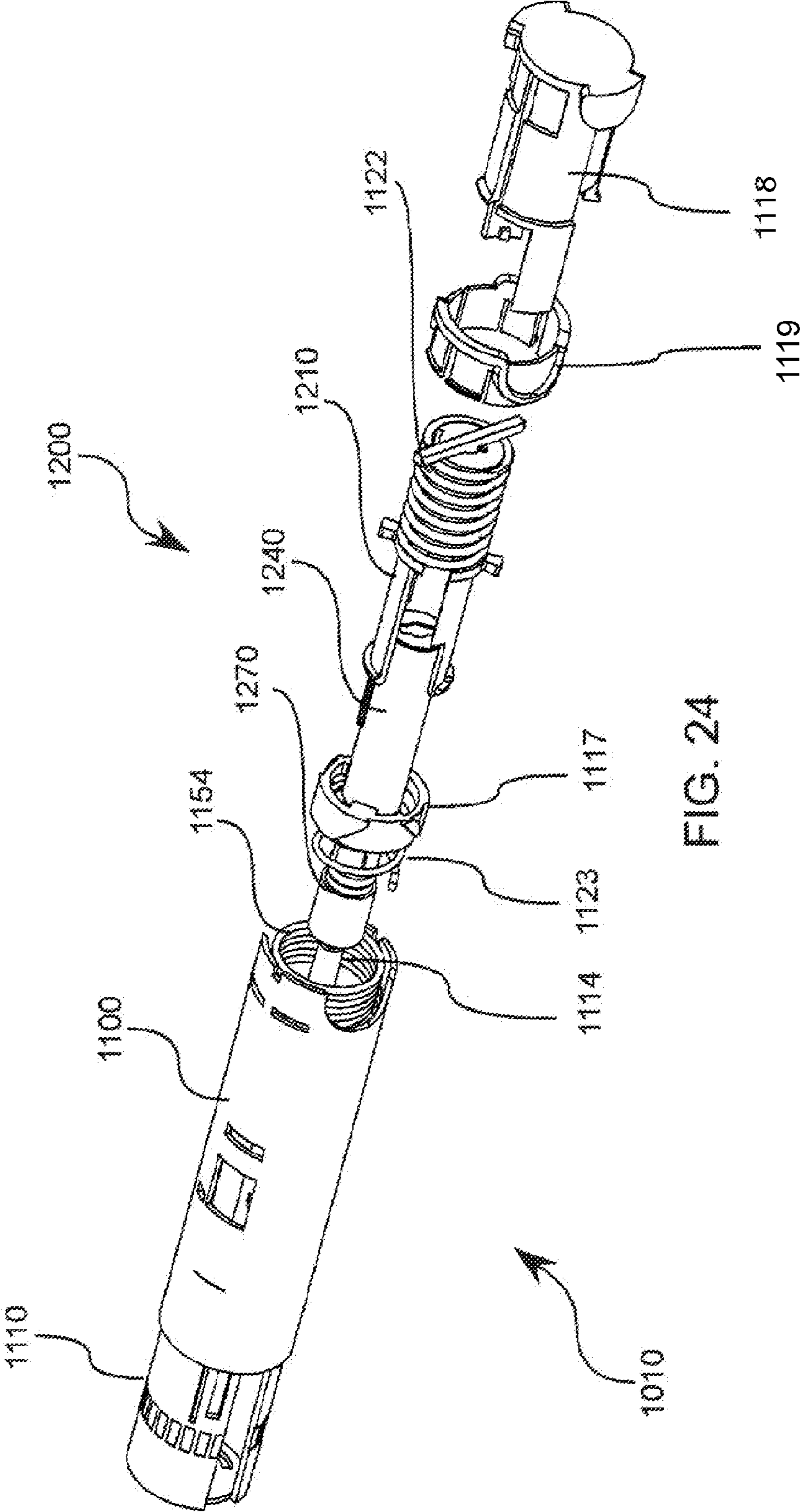

FIG. 24

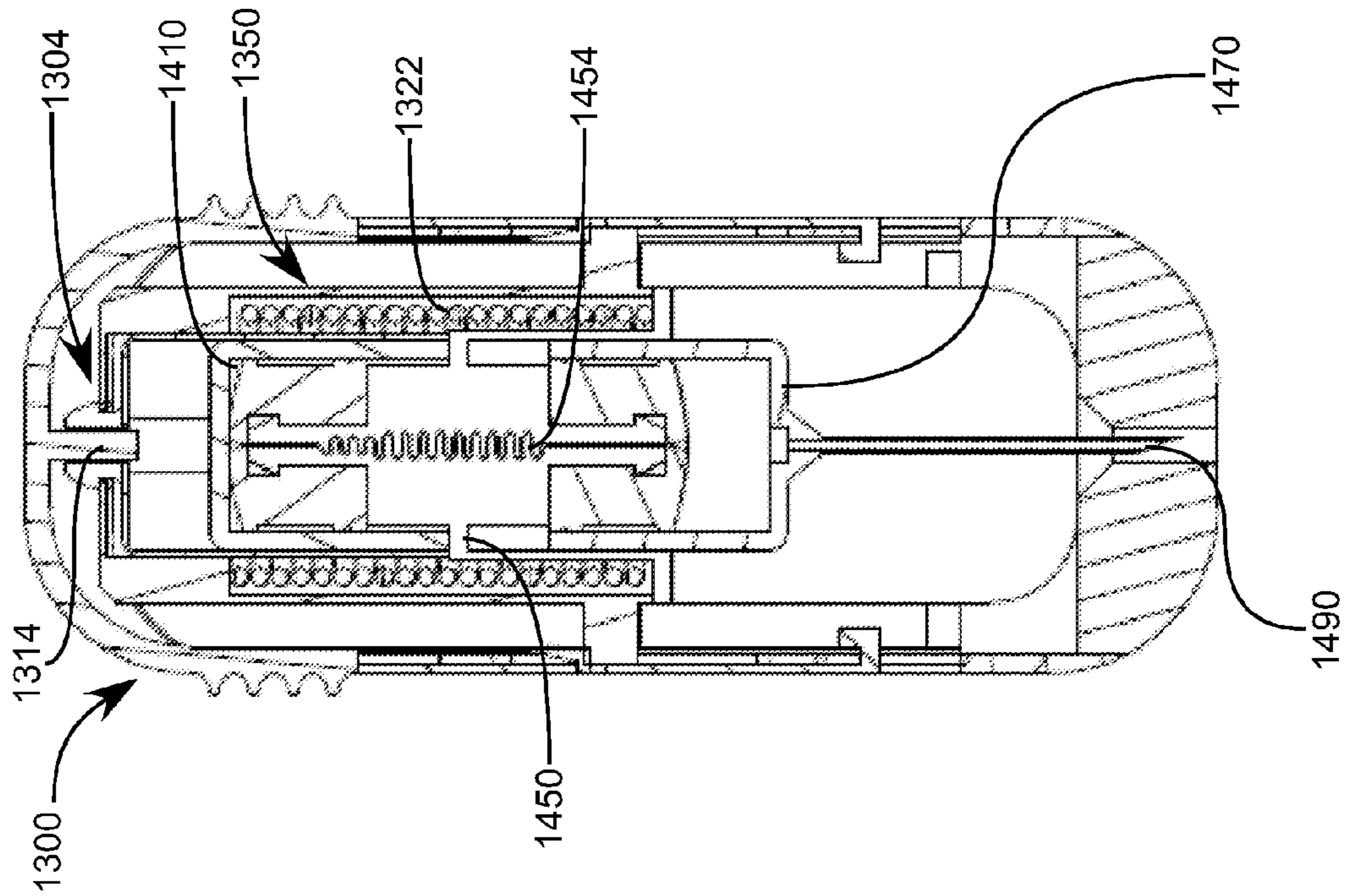

FIG. 25B

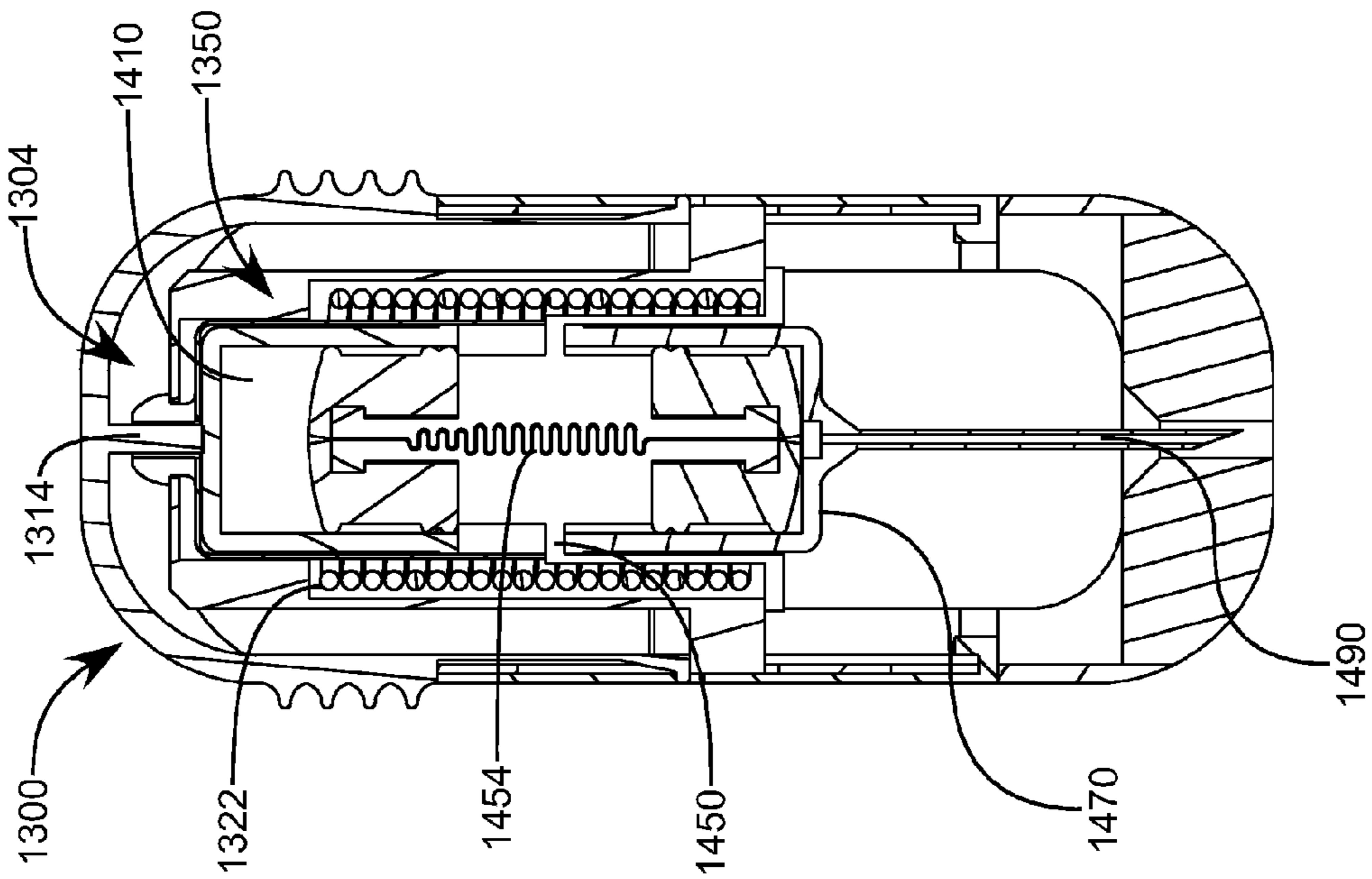

FIG. 25A



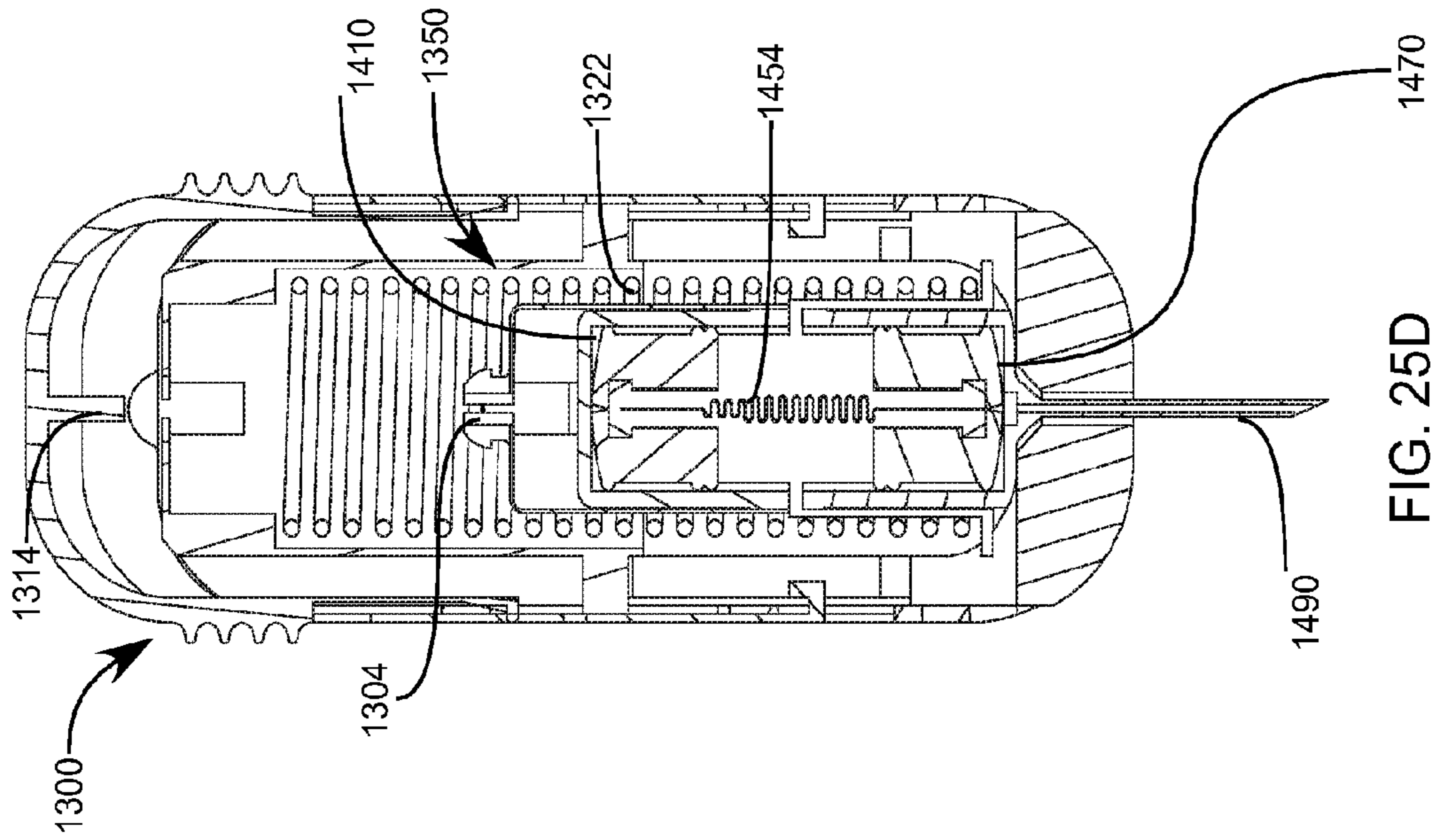

FIG. 25D

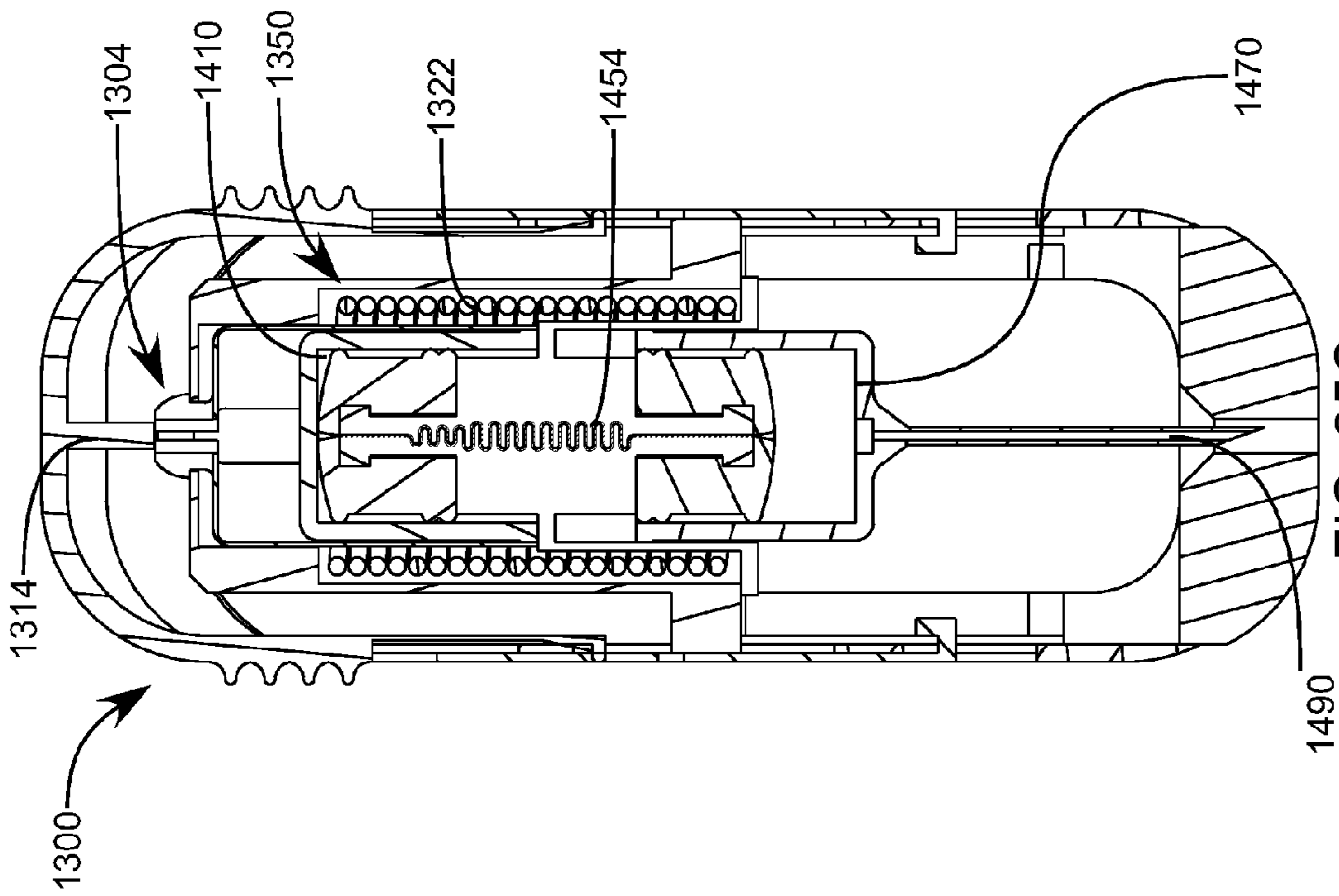

FIG. 25C

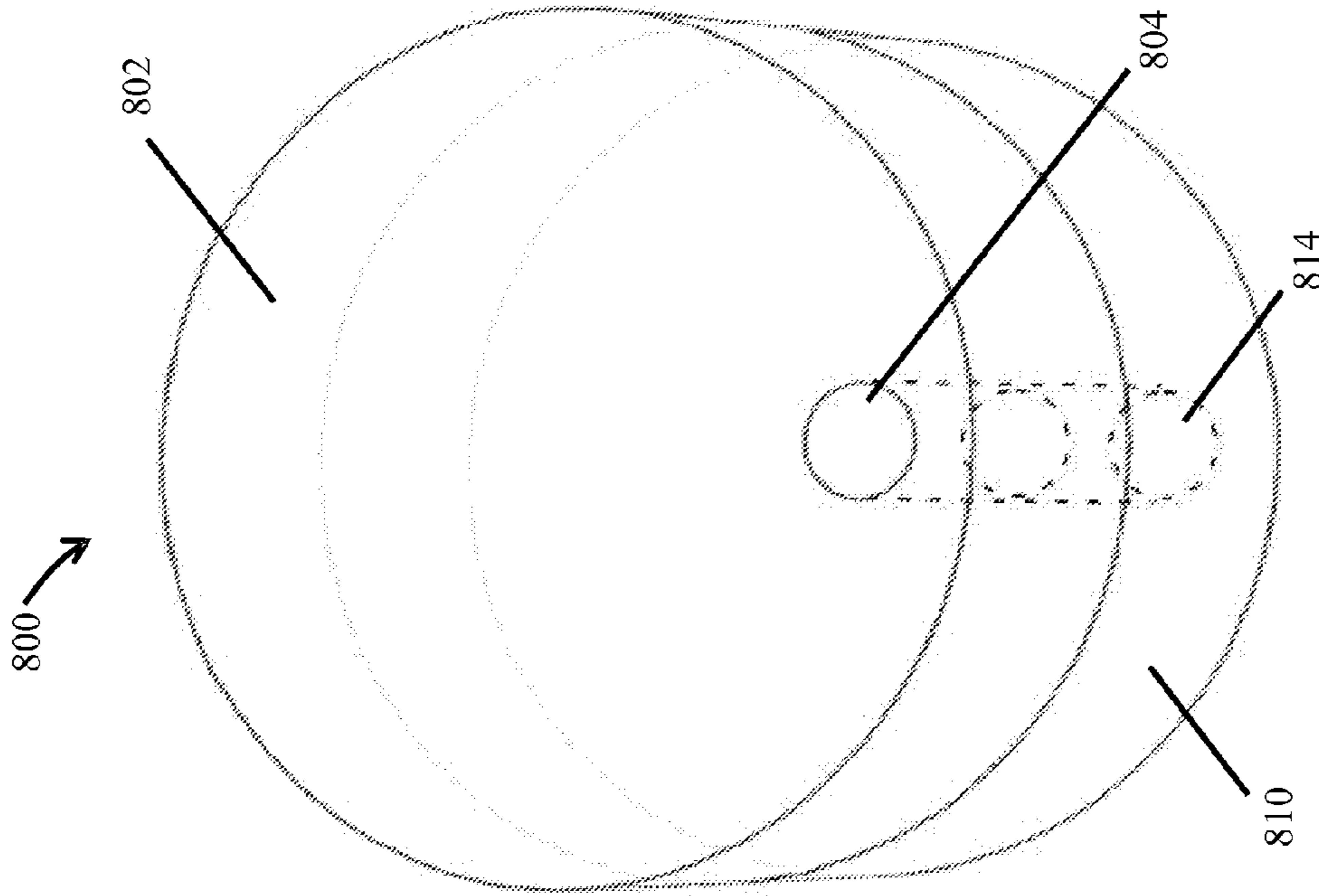

Fig. 26B

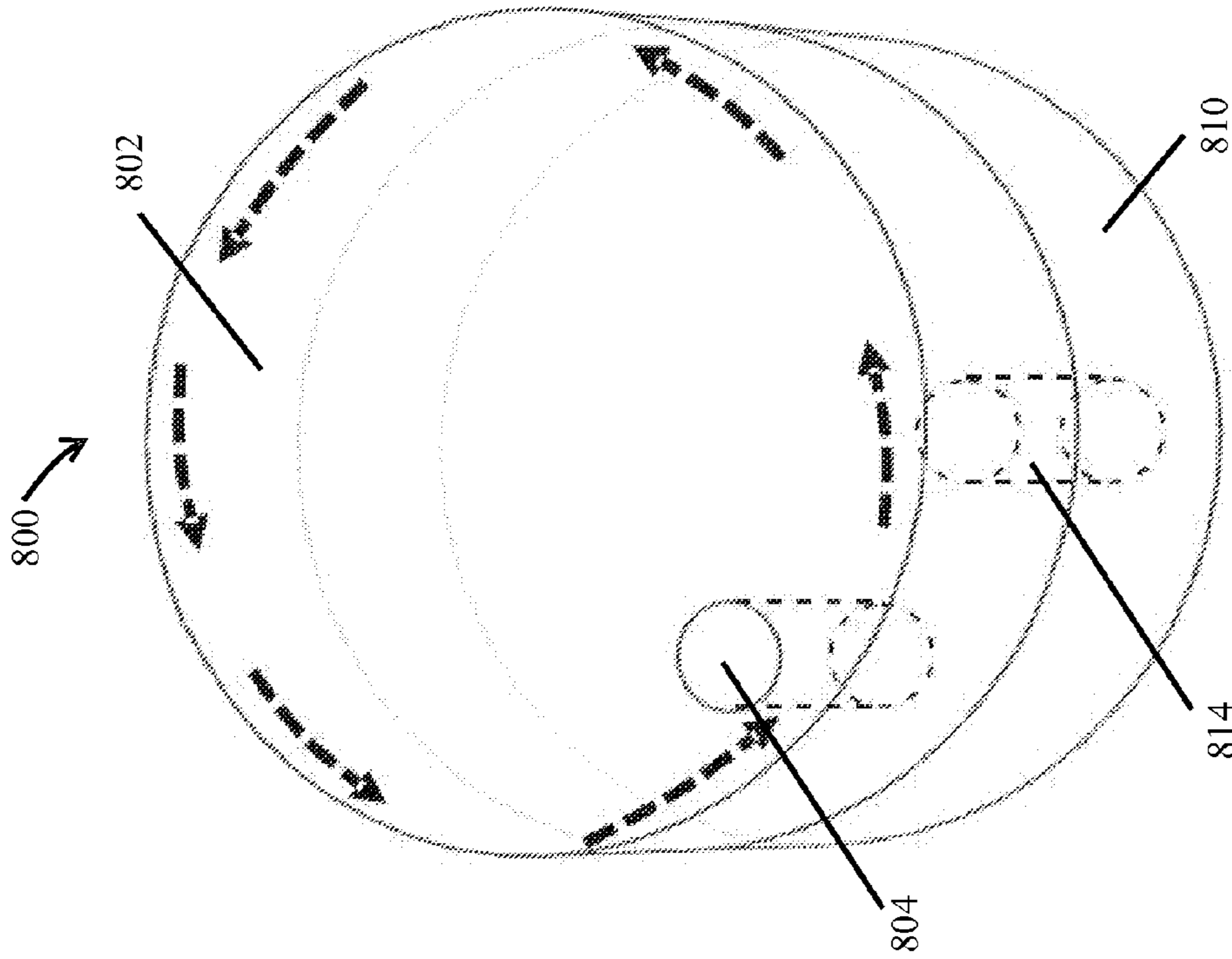

Fig. 26A

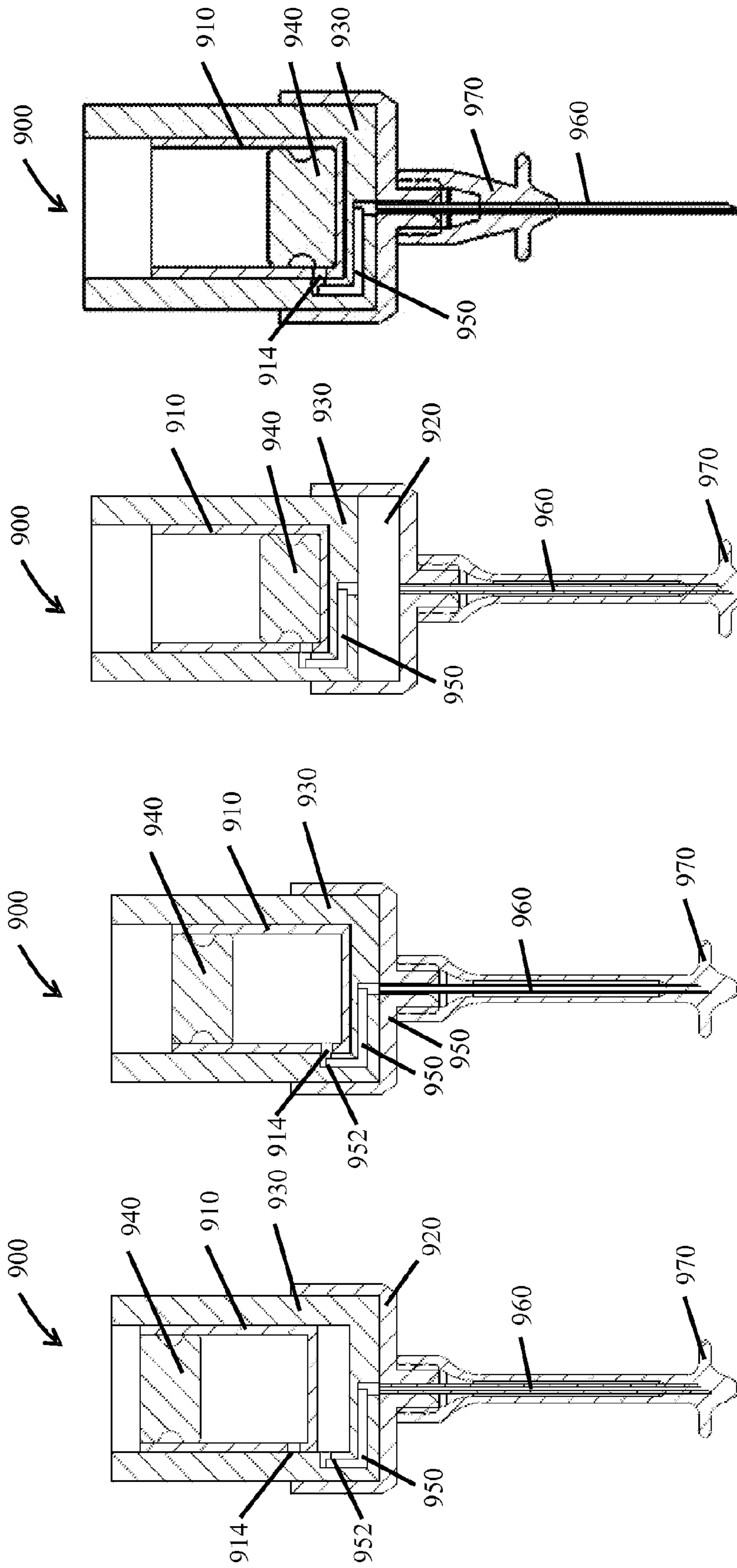

Fig. 27D

Fig. 27C

Fig. 27B

Fig. 27A

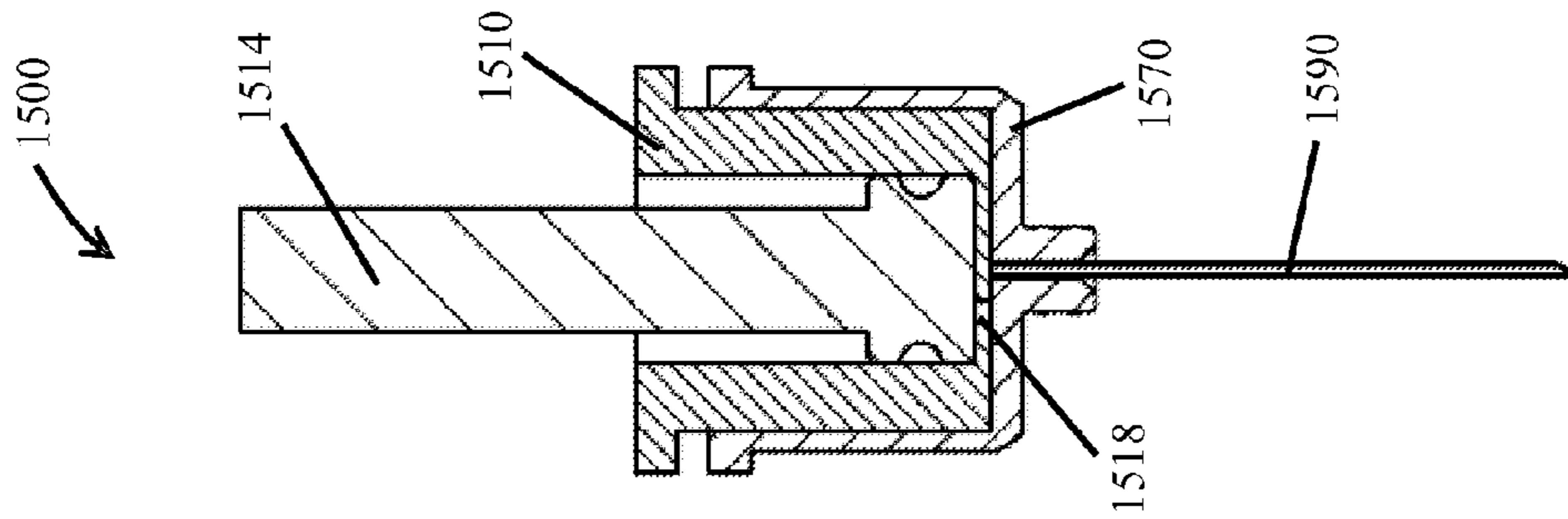

Fig. 28C

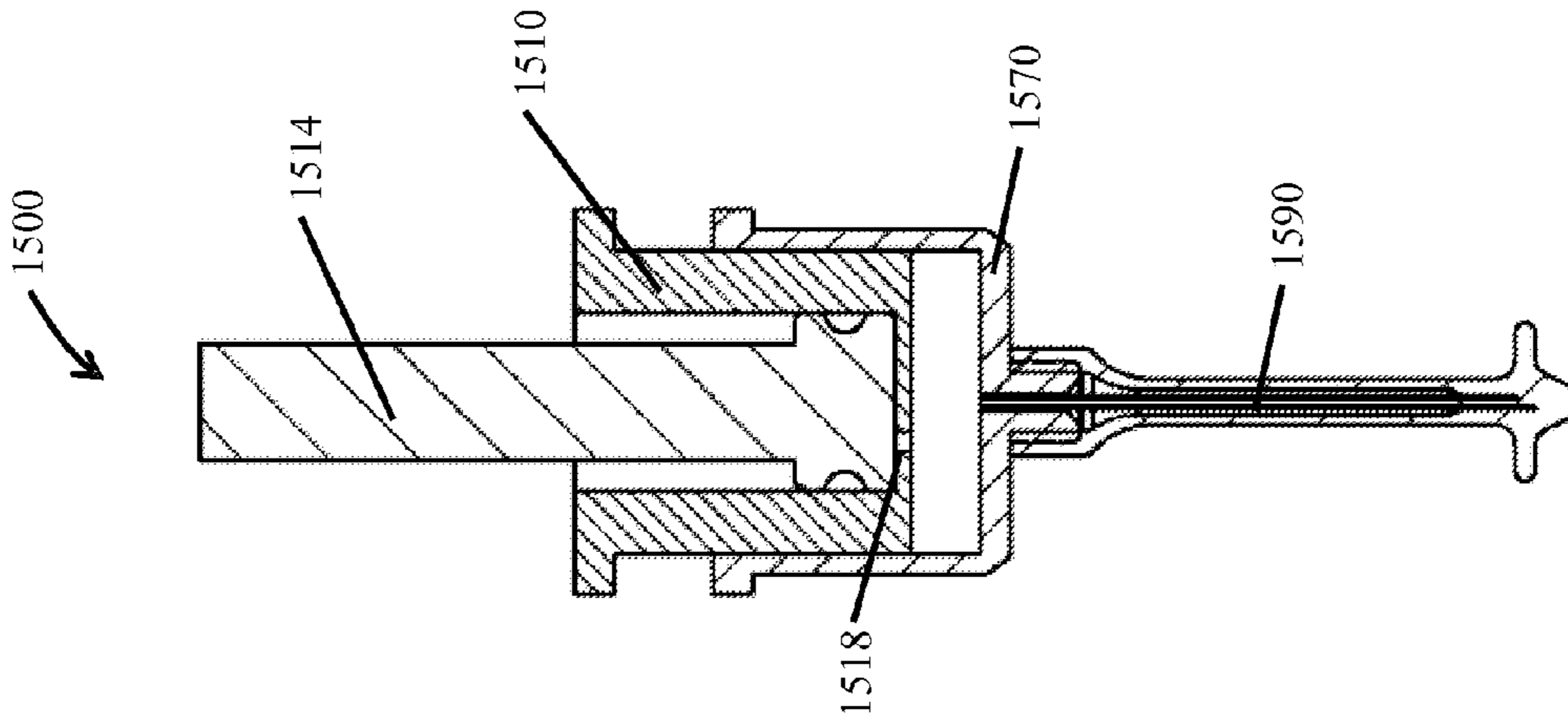

Fig. 28B

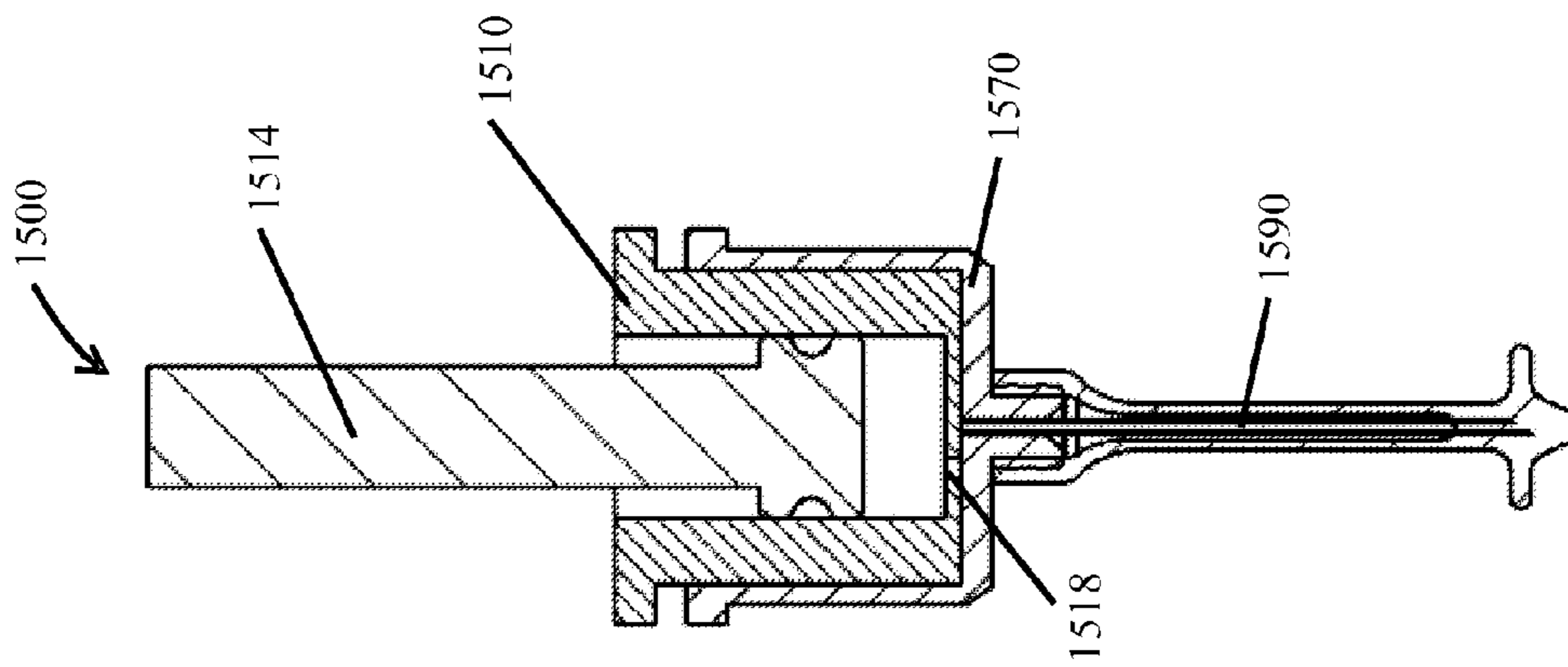

Fig. 28A

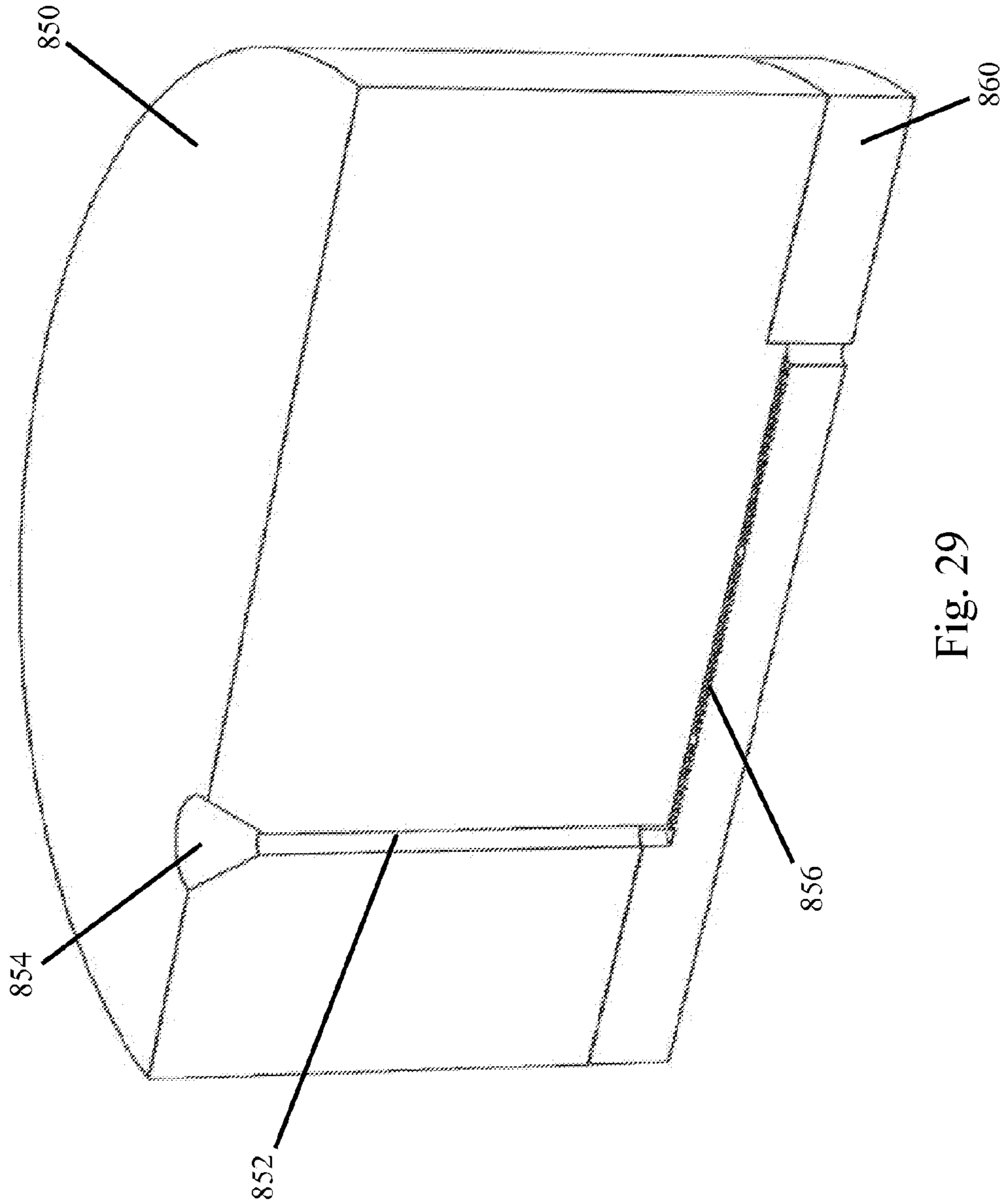

Fig. 29

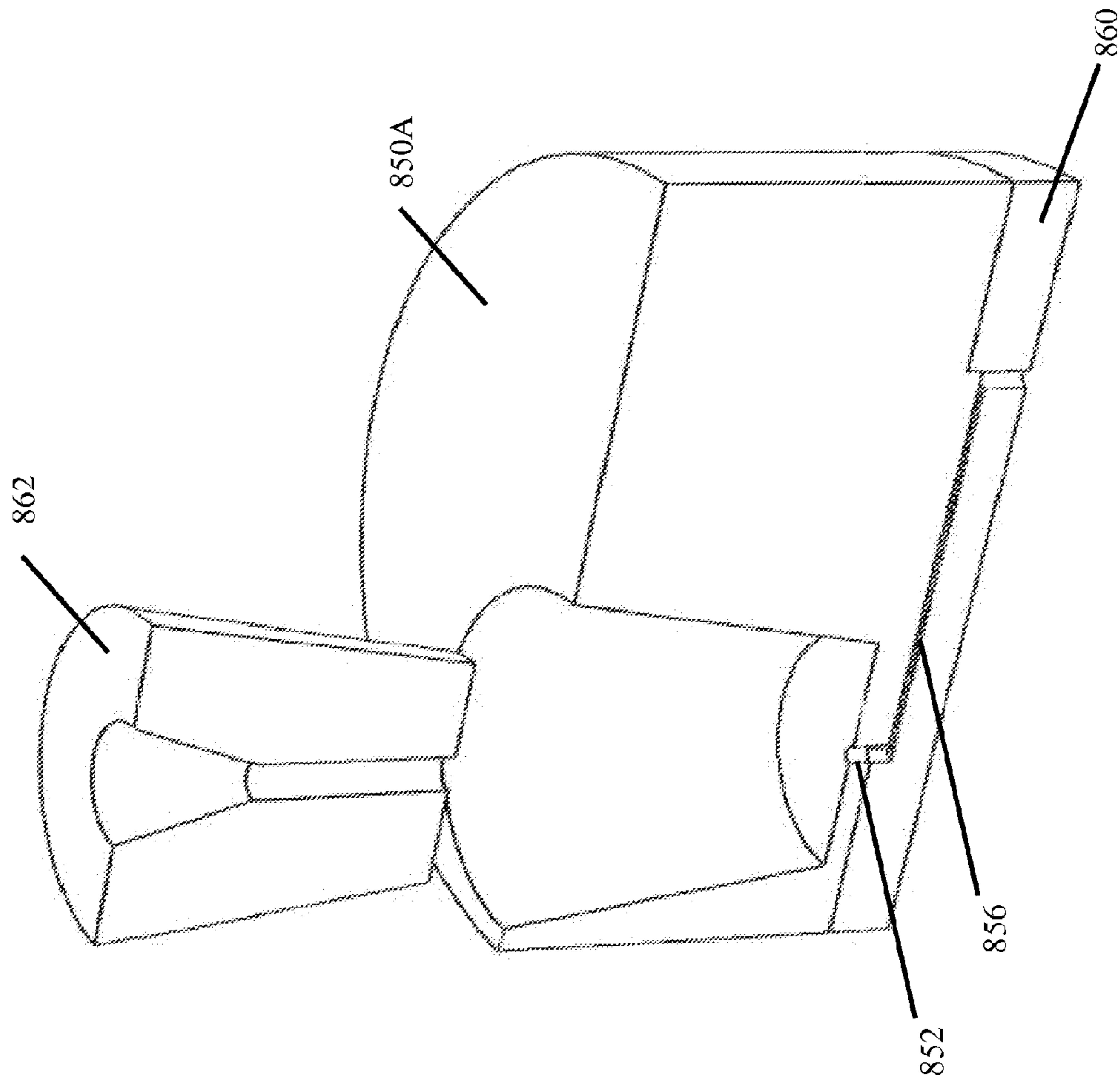

Fig. 30

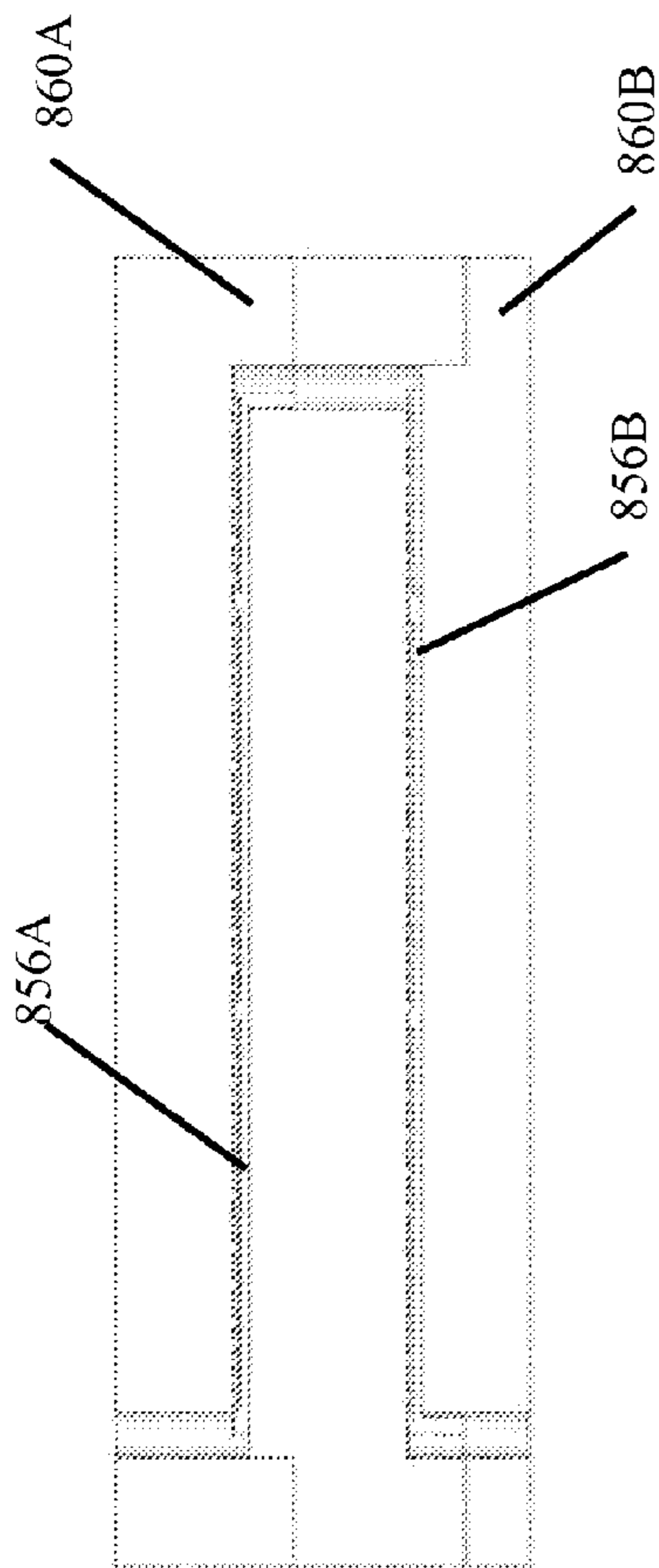

Fig. 31A

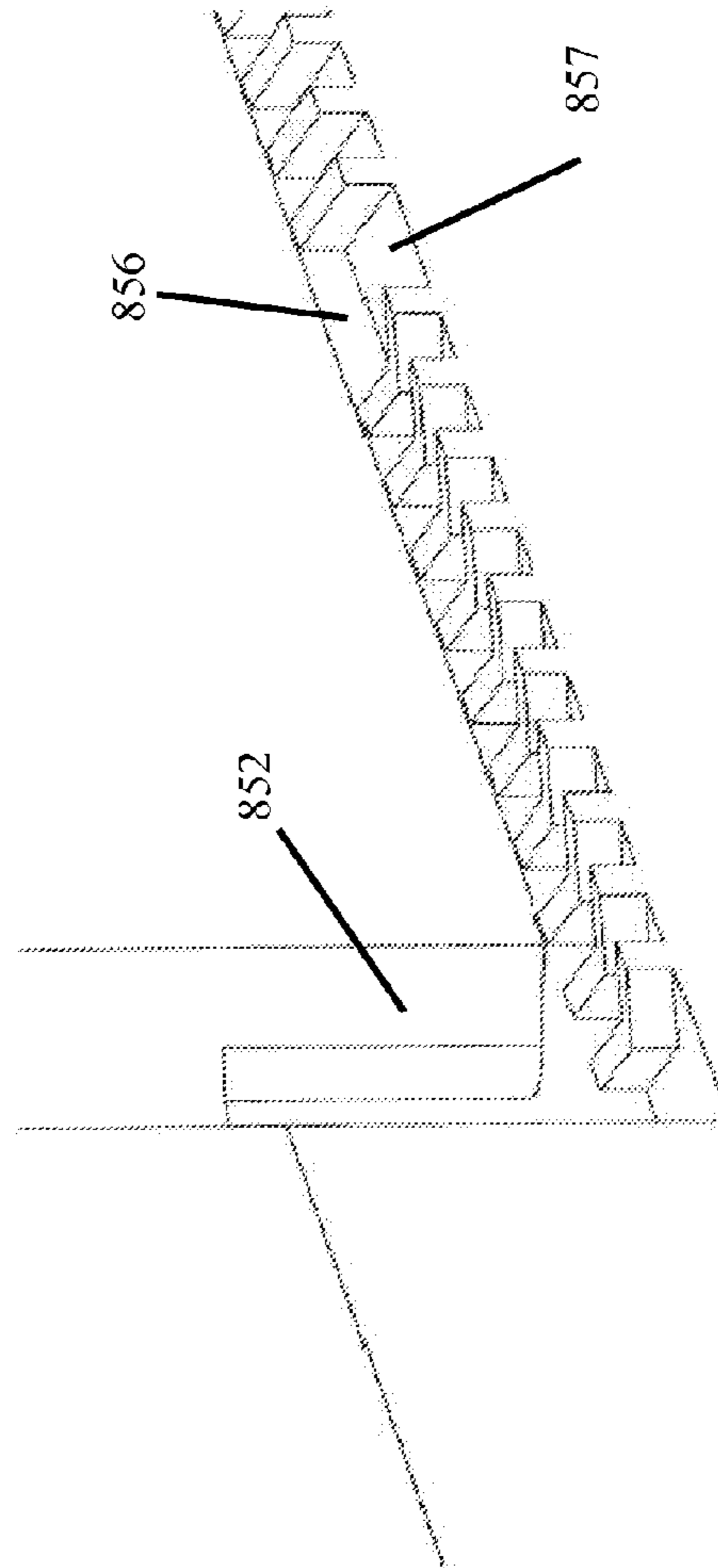
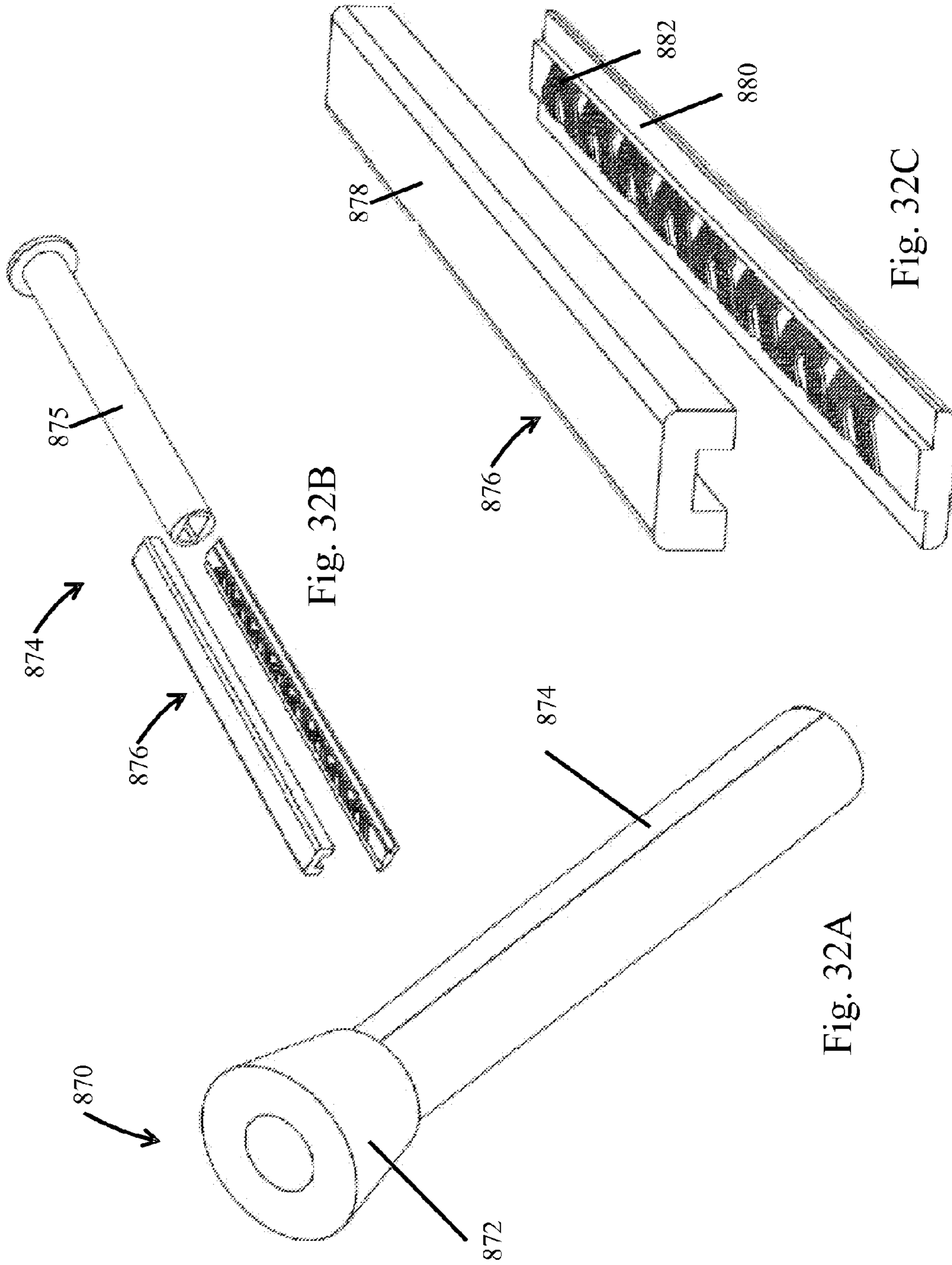

Fig. 31B





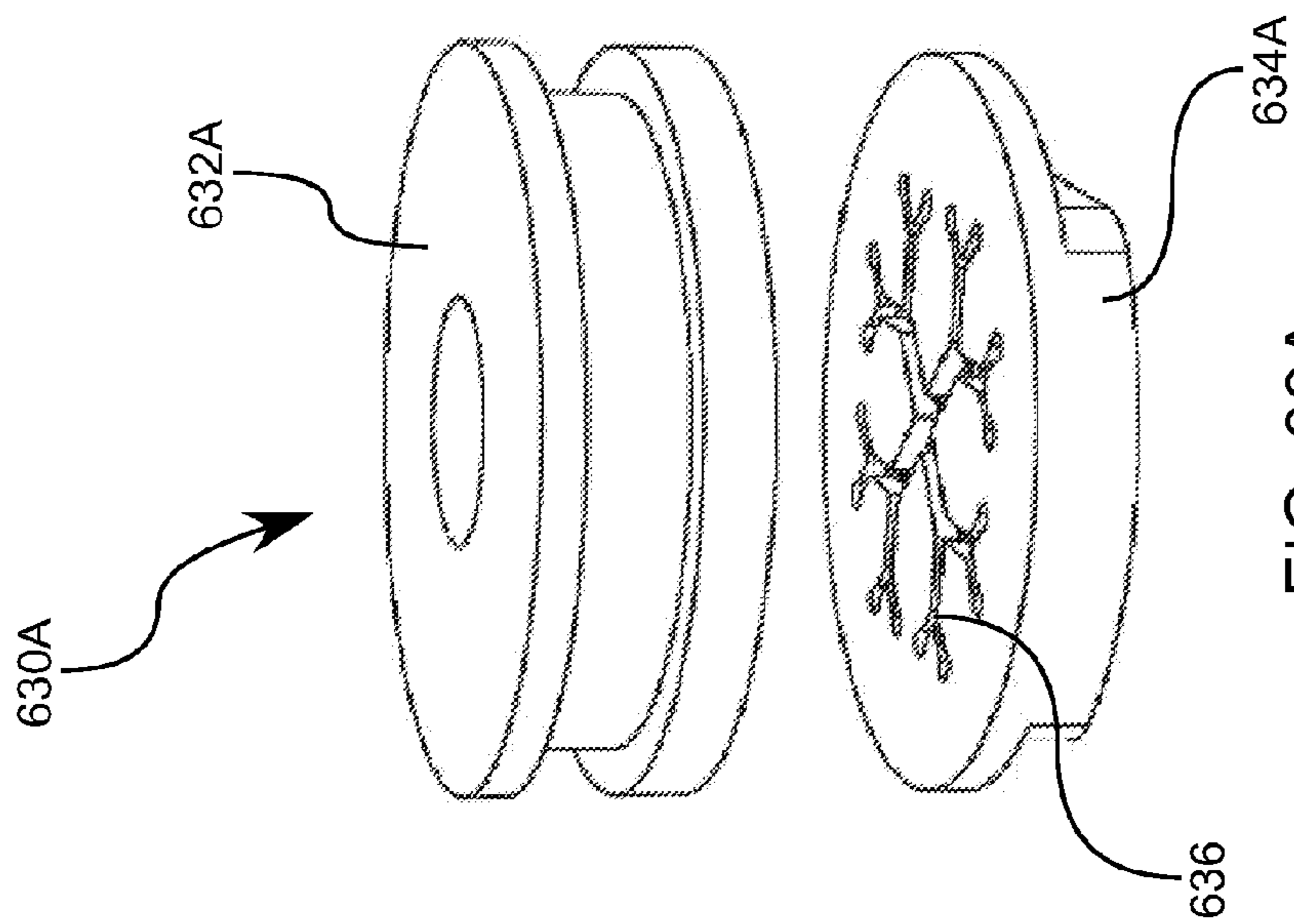

FIG. 33A

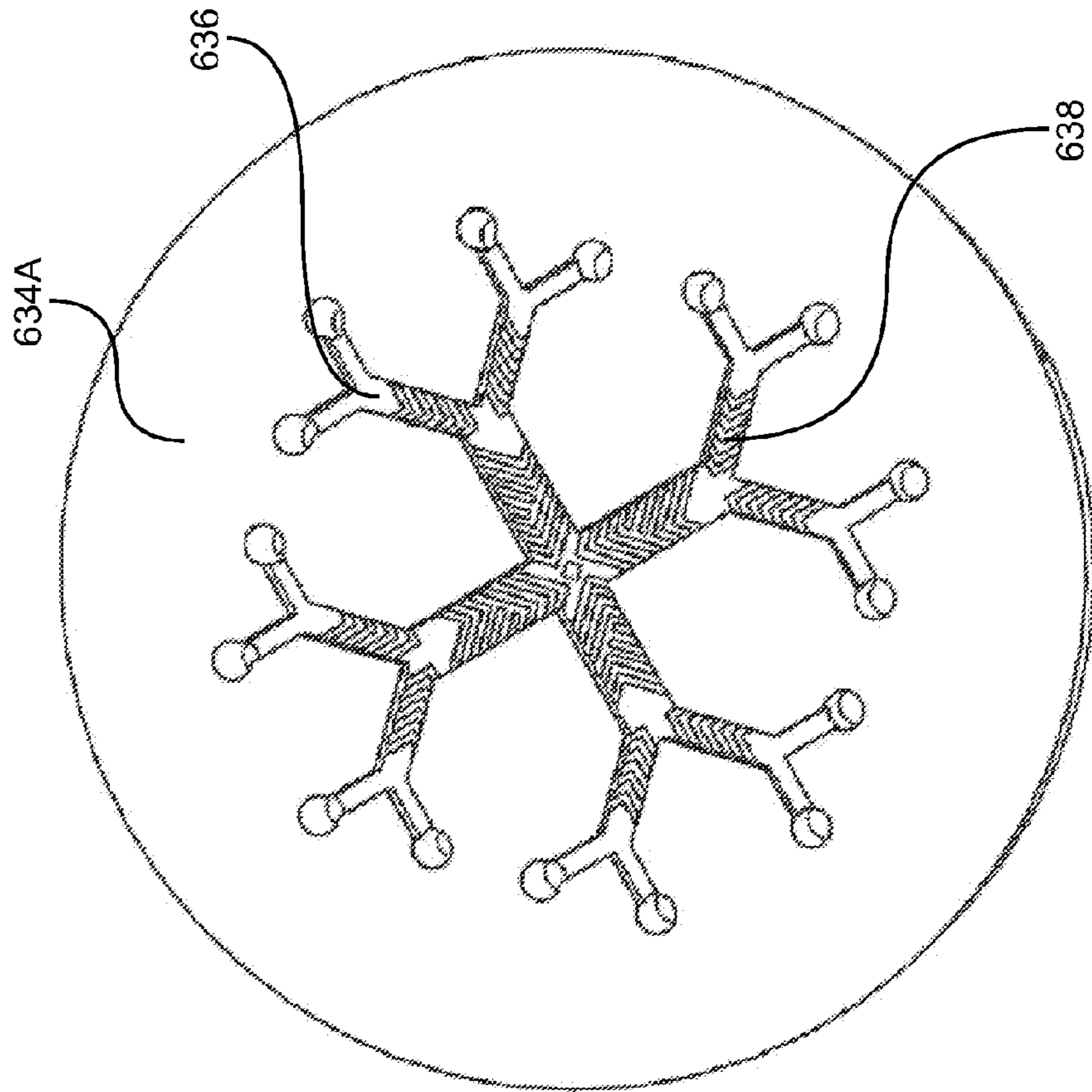

FIG. 33B

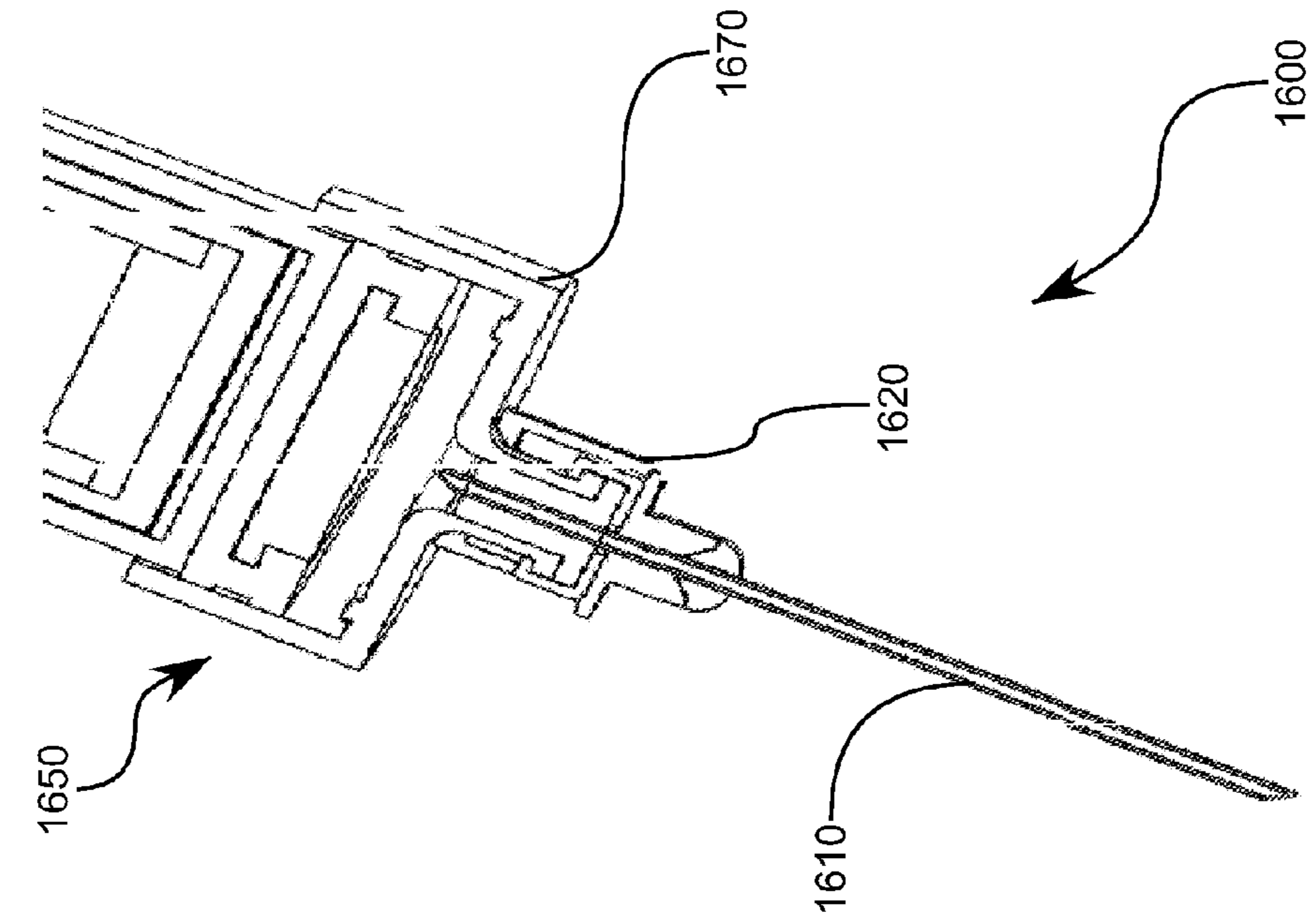

FIG. 34B

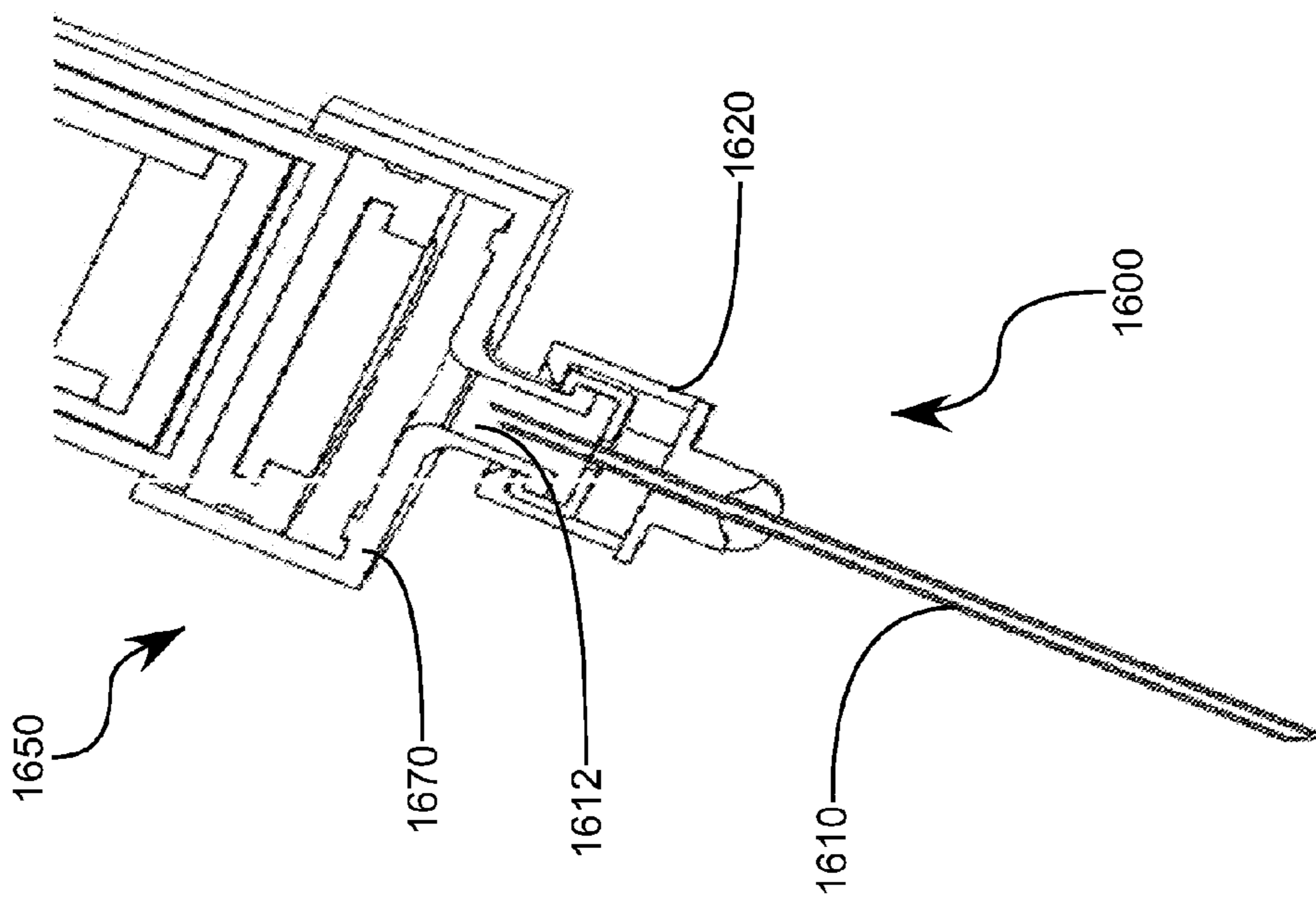

FIG. 34A

## PORTABLE DRUG MIXING AND DELIVERY DEVICE AND ASSOCIATED METHODS

### CROSS-REFERENCE TO RELATED APPLICATIONS

This application claims the benefit of U.S. Patent Application No. 62/038,386 filed on Aug. 18, 2014 and U.S. Patent Application No. 62/126,011 filed on Feb. 27, 2015, which are herein incorporated by reference in their entirety.

### FIELD OF THE INVENTION

The present invention relates generally to auto-injectors and prefilled syringes and more particularly to auto-injectors that store in a compact state and allow for formation or reconstitution of a therapeutic agent for injection.

### BACKGROUND OF THE INVENTION

Individuals who suffer from certain medical conditions are often required to keep an auto-injector or prefilled syringe nearby in order to address a medical need. A few examples of this are insulin pens for people with diabetes, epinephrine for those with food and insect stings allergies, and antidotes for soldiers at risk of exposure to chemical and/or biological toxins in the field. For example, an allergic reaction may occur in a location which is physically distant from the nearest hospital or medical facility. For example, bee stings, are more likely to occur outside than indoors. Food containing peanuts are more likely to be supplied to the individual away from a controlled home environment like at a baseball park. Having a portable epinephrine auto-injector nearby enables emergency intervention after an exposure to an allergen.

Size is an issue when it comes to auto-injectors. Many owners of the devices are hesitant to carry their injector with them if it represents a burden, by providing injectors in more compact sizes it will make it more likely that they will.

Shelf-life is also a large issue with respect to auto-injectors, which can be expensive and used fairly infrequently. For example a user who has intense allergic reactions to shellfish can go years between exposures and subsequent injections. In such a case it can be easy to forget to replace the auto-injector after expiration, whereupon in an emergency, the drugs contained therein have expired and are either ineffective or have a greatly reduced effectiveness due to decomposition of the drugs contained therein. As will be appreciated by those having skill in the art, the shelf life can be increased by storing the desired medication in an unmixed and dry state and dissolved just prior to injection. This ability to store the wet and dry components separately within the device can increase the shelf life and thus increase the likelihood that the user will have an injector with effective dosages when an emergency arises.

In such devices it is required that the mixing and reconstitution processes are consistent and complete prior to injection.

### SUMMARY OF THE INVENTION

It has been recognized that if a drug can be kept out of the liquid phase and stored as a dry medication, the shelf-life can be substantially increased and temperature susceptibility can be decreased substantially thus allowing the efficacy and potency of the drug to endure longer and through harsher environments.

It has been recognized that a smaller drug delivery device than a conventional epinephrine auto-injector, which could be attached to a key chain and/or easily fit in a person's pocket, would make the device easier to carry and more likely that the user will have it on their person when needed. Various structures are contemplated herein which address many of the problems discussed above through the use of mixing structures, and actuation devices which ensure proper storage integrity, and full mixing prior to injection.

Contemplated herein is a medication mixing and delivery device which can include a housing, a first chamber being located within the housing, the first chamber containing a first medicament component, and a second chamber located within the housing, the second chamber configured to selectively receive the first medicament component from the first chamber. A second medicament component stored can then be stored somewhere within the housing but outside the first chamber. A valve can then also be provided which is located within the housing between the first and second chamber, the valve being configurable so as to provide selective fluidic communication between the first chamber and the second chamber.

A first displacement mechanism can be provided in conjunction with the first chamber, and be configured so as to reduce the effective volume of the first chamber, the first displacement mechanism can further be configured so as to axially translate the second chamber with respect to the first chamber during a first actuation. Additionally, a second displacement mechanism configured to reduce the effective volume of the second chamber.

An actuation device having a pre-loaded energy source, such as a spring or compressed gas chamber can be utilized to drive the first and second displacement mechanisms or otherwise provide actuation of various actuation mechanisms within the housing.

In some embodiments the actuation device can be provided in mechanical communication with the valve, the actuation device being configured to change the valve between a closed state and an open state during a first actuation.

In yet alternative embodiments an intermediate support can be provided within the housing, wherein a rotation of the intermediate support about its axis effectuates the first actuation of the actuation device.

In some embodiments the first displacement mechanism can include at least one radial protrusion which is configurable to engage a channel formed in the intermediate support. In some such embodiments the channel has can include a first portion, a second portion, and an intermediate stop disposed between the first and second portions, wherein the second portion of the channel is offset from the first portion. In this manner the first actuation moves the at least one radial protrusion relative to the first portion of the channel so as to change relative states of the device.

In some embodiment a second trigger can be provided which is mechanically coupled to the at least one radial protrusion, wherein triggering the second trigger causes the at least one radial protrusion to engage with the second portion of the channel.

Also contemplated herein is a medication-mixing device which includes a housing, and a frame disposed within the housing, the frame having at least one channel on an inner surface thereof. A first chamber can then be provided which is located within the housing, the first chamber containing a first medicament component. A second chamber can then be provided which is also located within the housing, the second chamber configurable to selectively receive the first

medicament component from the first chamber. A valve can then be provided and located within the housing, the valve configured to provide selective fluidic communication between the first chamber and the second chamber upon activation of a first displacement mechanism which is configured to reduce the effective volume of the first chamber displacing the first medicament component into the second chamber and thus mix with a second medicament component stored within the housing and outside the first chamber. A second displacement mechanism can then be provided and configured so as to reduce the effective volume of the second chamber and selectively eject the mixed medicament components.

In some embodiments an actuation device can be provided which can include a pre-loaded energy source such as a spring or compressed air chamber. This actuation device can then be provided in mechanical communication with the valve, the actuation device also can be configured so as to change the valve between a closed state and an open state during a first actuation.

In this embodiment, at least one plunger protrusion can be provided and disposed about an outer circumference of the first displacement mechanism. This at least one plunger protrusion can be configured to engage the at least one channel of the frame. In such a case the first actuation can then be effectuated by moving the at least one plunger protrusion relative to and within its respective channel.

In some embodiments an intermediate support can be provided and disposed within the frame, the intermediate support can include at least one intermediate support protrusion which engages with the at least one channel of the frame.

In yet additional embodiments the frame can further include an intermediate stop formed in the at least one channel, the intermediate stop being configured to engage the intermediate support protrusion during an intermediate stage, wherein the intermediate stop temporarily prevents further actuation. In such an embodiment the plunger protrusion can be configured so as to rest upon the intermediate support protrusion in the intermediate stage.

In yet additional embodiments the mixing device can include a delivery assembly which can be configured to be in fluid communication with the second chamber during a second actuation, and wherein the delivery assembly can be extended during the second actuation of the actuation device.

In various embodiments a trigger can be provided which is in mechanical communication with the intermediate support, wherein depressing the trigger causes the intermediate support protrusion to be released from the intermediate stop in a respective channel.

In some embodiments a first actuation step can be configured so as to allow the first medicament component stored in the first chamber to be displaced by the first displacement mechanism and transfer at least partially into the second chamber, and mix with the second medicament component, and wherein a second actuation causes the second displacement mechanism to displace the mixed medicament through a delivery assembly.

Also contemplated herein is a medication mixing and delivery device which can include a housing, a first chamber being located within the housing, the first chamber containing a first medicament component, and a second chamber located within the housing, the second chamber configured to selectively receive the first medicament component from the first chamber. A second medicament component can be stored within the housing and outside the first chamber and

be configured to be received in the second chamber and mixed with the first medicament component. A valve can also be provided and located within the housing, the valve configurable so as to provide selective fluidic communication between the first chamber and the second chamber;

Each of the first and second chambers can be provided with a respective first or second displacement mechanism which can be configured so as to reduce the effective volume of its respective chamber.

An actuation device can then be provided which can include a pre-loaded energy source such as a spring or compressed air chamber can be provided and selectively actuated by the actuation device so as to drive the components of the device and thus change between various states. The actuation device can also be provided in mechanical communication with the valve, the actuation device being configured to change the valve between a closed state and an open state during a first actuation.

In some embodiments a needle shield assembly can be provided which includes a needle shield having a cam ramp provided in a sidewall of the needle shield, wherein the cam ramp is in mechanical communication with the actuation device, and wherein a depression of the needle shield causes a second actuation. In some embodiments a depressing of the needle shield can cause the second actuation of the actuation device to release a second portion of energy that extends the delivery assembly and displaces a mixed medicament in the second chamber from the second chamber through the delivery assembly.

The various embodiments herein can further include a delivery assembly which is in fluid communication with the second chamber.

In yet additional embodiments a frame and intermediate support can be provided and disposed within the housing, wherein the intermediate support has an interface to engage the cam ramp, and wherein depressing the needle shield causes the intermediate support to translate axially within the frame.

In some embodiments the needle shield can be provided as a hollow shroud having a sidewall and an aperture on one end, and where a needle may pass through the aperture when the needle shield is not in a fully-extended state. In some such embodiments the needle shield assembly can further include a secondary spring which biases the needle shield and extends the needle shield beyond the needle after the needle has been removed from an injection site. In yet alternative such embodiments the needle shield assembly can further include a locking mechanism, which is triggered after the needle shield depression, and is configured to lock in the extended position.

Also contemplated herein is yet another embodiment of a medication mixing and delivery device which can include a housing, a first chamber having an aperture, the first chamber being located within the housing, the first chamber containing a first medicament component, and a second chamber located within the housing, the second chamber configured to selectively receive the first medicament component from the first chamber. A valve can then be located within the housing, the valve being configurable so as to provide selective fluidic communication between the first chamber and the second chamber.

A first displacement mechanism can be provided which is configurable so as to reduce the effective volume of the first chamber, along with a second displacement mechanism which can be configurable so as to reduce the effective volume of the second chamber.

In some embodiments a second medicament component can be stored within the housing and outside the first chamber, such as in a fluidic channel provided between the outlet of the first chamber and the inlet of the second chamber, or alternatively within the second chamber itself. 5

In some embodiments an actuation device can be provided, which can include a pre-loaded energy source such as a spring or compressed gas chamber, wherein the actuation device is in mechanical communication with the valve, the actuation device being configurable so as to change the valve between a closed state and an open state and cause the first displacement mechanism to reduce the effective volume during a first actuation. In addition such an actuation device can additionally be configurable so as into cause the second displacement device to reduce the effective volume during a second actuation. In some such embodiments a rotatable and releasable mechanical stop can be provided and positioned within the housing so as to engage the actuation device at the end of the first actuation, and wherein the rotatable and releasable mechanical stop is configured to release the actuation device at the beginning of the second actuation. In some such embodiments a trigger assembly can be provided wherein a depression of the trigger assembly overcomes the rotatable and releasable mechanical stop so as to allow a second actuation of the actuation device. 10 15 20 25

In some such embodiments a delivery assembly can be provided which can be further selectively arranged so as to be in fluid communication with the second chamber.

In yet alternative embodiments an intermediate support can be provided and disposed within the housing and about at least a portion of an outer surface of the first chamber, wherein the intermediate support has a protrusion that forms a part of the rotatable and releasable mechanical stop. 30

Also contemplated herein is a method of mixing and delivering a medicament, the method including various steps, such as: displacing a first medicament stored in a first chamber through an outlet of the first chamber into an inlet of the second chamber through a valve, wherein the valve can alternate between a closed state and open state during a first actuation; triggering the first actuation by axially translating a first displacement device to displace a volume in a first chamber, wherein the first displacement device has a protrusion that interfaces with a channel formed in a side-wall of a frame of a housing that contains the first and second chambers; stopping the first actuation by preventing travel of the protrusion along the channel by a mechanically releasable stop; triggering a second actuation by releasing the mechanically releasable stop, wherein a first medicament displaced from the first chamber mixed with a second medicament stored outside the first chamber during the first actuation and stored in the second chamber, wherein the second actuation displaces the mixed medicament stored in the second chamber by a second displacement mechanism through a delivery assembly. 35 40 45 50

In alternative embodiments, the method can also include: extending the delivery assembly during the second actuation; and providing a needle shield assembly, wherein the needle shield assembly is formed about the delivery assembly, the needle shield assembly further including a needle shield that forms in part a trigger for triggering the second actuation. 55 60

These aspects of the invention are not meant to be exclusive and other features, aspects, and advantages of the present invention will be readily apparent to those of ordinary skill in the art when read in conjunction with the following description, appended claims, and accompanying drawings. Further, it will be appreciated that any of the 65

various features, structures, steps, or other aspects discussed herein are for purposes of illustration only, any of which can be applied in any combination with any such features as discussed in alternative embodiments, as appropriate.

#### BRIEF DESCRIPTION OF THE DRAWINGS

The foregoing and other objects, features, and advantages of the invention will be apparent from the following description of particular embodiments of the invention, as illustrated in the accompanying drawings in which like reference characters refer to the same parts throughout the different views. The drawings are not necessarily to scale, emphasis instead being placed upon illustrating the principles of the invention, wherein:

FIGS. 1A-C illustrate perspective exterior views of a medication mixing and delivery device through various actuation steps;

FIGS. 2A-B illustrate perspective exploded views of the medication mixing and delivery device and a mixing subassembly in accordance with the embodiment of FIGS. 1 A-C;

FIGS. 3A-D illustrate side cross sectional views of a medication mixing and delivery device through various actuation steps in accordance with the embodiment of FIGS. 1 A-C;

FIGS. 4A-D illustrate side cross sectional views of the mixing subassembly through various actuation steps for use in conjunction within the embodiment of FIGS. 1 A-C;

FIGS. 5A-E illustrate various exterior perspective views of the mixing subassembly through various actuation steps moving from a stowed state to a mixed state as would be effectuated using the embodiment of FIGS. 1 A-C;

FIGS. 6A-E illustrate various exterior perspective views and cross sectional views of the enlarged area of the mixing subassembly as indicated by area A in FIG. 5E;

FIGS. 7A-D illustrate various perspective and cross sectional views of a frame being used within the medication mixing and delivery device of FIGS. 1A-C;

FIGS. 8A-E illustrate various exterior perspective views of the mixing subassembly and a secondary actuation mechanism through various actuation steps moving from the mixed state to an injected state as would be effectuated using the embodiment of FIGS. 1 A-C;

FIGS. 9A-B illustrate various exterior perspective views of a needle guard and associated subassembly through various actuation steps to shield an exposed needle after injection using the embodiment of FIGS. 1 A-C;

FIGS. 10A-D illustrate perspective exterior views of an alternative embodiment of a medication mixing and delivery device through various actuation steps;

FIGS. 11A-C illustrate various perspective and cross sectional views of a cap for use in the medication mixing and delivery device of FIGS. 10A-D;

FIGS. 12A-E illustrate side exterior exploded views of the medication mixing and delivery device, a housing assembly, a mixing assembly, a delivery assembly and a needle guard assembly, respectively;

FIGS. 13A-D illustrate various exterior perspective, side, and cross sectional views of the medication mixing and delivery device as illustrated in FIGS. 10A-D in a stowed state;

FIGS. 14A-C illustrate various exterior perspective, side, and cross sectional views of the medication mixing and delivery device as embodied in FIGS. 10A-D illustrating a first actuation step so as to initiate mixing;

FIGS. 15A-C illustrate various exterior perspective, side, and cross sectional views of the medication mixing and delivery device as embodied in FIGS. 10A-D illustrating an actuated state;

FIGS. 16A-C illustrate various side, cross sectional, and partially transparent views of the medication mixing and delivery device as embodied in FIGS. 10A-D illustrating a mixed state;

FIGS. 17A-B illustrate side and cross sectional views of the medication mixing and delivery device as embodied in FIGS. 10A-D illustrating an injection ready state;

FIGS. 18A-D illustrate various perspective views of a second actuation mechanism of the medication mixing and delivery device as embodied in FIGS. 10A-D illustrating changing from the mixed state to an injected state;

FIGS. 19A-B illustrate side and cross sectional views of the medication mixing and delivery device as embodied in FIGS. 10A-D illustrating an injection complete state;

FIGS. 20A-D illustrate various perspective, side and cross sectional views of the medication mixing and delivery device as embodied in FIGS. 10A-D illustrating a needle shield lockout mechanism;

FIGS. 21A-B illustrate a perspective and cross sectional view, respectively, of yet another alternative embodiment of a medication mixing and delivery device in a stowed state;

FIGS. 22A-E illustrate various cross sectional views of the medication mixing and delivery device of FIGS. 21A-B through various actuation steps;

FIGS. 23A-D illustrate various cross sectional detailed views of a mixing assembly for use with the medication mixing and delivery device of FIGS. 21A-B through various actuation steps;

FIG. 24 illustrates a perspective exploded view of a mixing assembly for use with the medication mixing and delivery device of FIGS. 21A-B through various actuation steps;

FIGS. 25A-D illustrate various cross sectional views of yet another alternative embodiment of a medication mixing and delivery device in various actuated states;

FIGS. 26A-B illustrate principles of a rotary valve adaptable for use in any of the embodiments discussed herein;

FIGS. 27A-D illustrate principles of a sliding valve adaptable for use in any of the embodiments discussed herein;

FIGS. 28A-C illustrate various cross sectional views of yet another alternative embodiment of a medication mixing and delivery device in various actuated states which utilize chambers which are independently movable within a housing;

FIG. 29 illustrates an exemplary fluidic channel arrangement adaptable for use in any of the embodiments discussed herein;

FIG. 30 illustrates an exemplary fluidic channel and removable ferrule arrangement adaptable for use in any of the embodiments discussed herein;

FIGS. 31A-B illustrate various features and embodiments of fluidic channel arrangements adaptable for use in any of the embodiments discussed herein;

FIGS. 32A-C illustrate various additional features of yet another alternative embodiments of a fluidic channel arrangement adaptable for use in any of the embodiments discussed herein;

FIGS. 33A-B illustrates various additional features of yet another alternative embodiment of a fluidic channel arrangement adaptable for use in various embodiments discussed herein; and

FIGS. 34A-B illustrate extended and retracted states of a delivery or injection assembly adaptable for use in any of the aforementioned embodiments.

## DETAILED DESCRIPTION OF THE INVENTION

It will be appreciated by those having skill in the area of fabrication and storage of drugs, that the lifespan and effectiveness of the drug can be increased substantially by keeping the medication in a dry state. Storage in a dry state also decreases the rate of degeneration as well as the degenerative effects of temperature, for example heat exposure. By keeping the drug in a dry state the breadth of environments where the device can be stored is increased while decreasing the frequency of required replacement.

The present invention illustrates various principles and devices which allow for the storage of a device having two or more components contained therein but which can quickly and reliably reconstitute, dissolve, fluidize, and/or put into a suspension, the components, i.e. mix them, immediately prior to delivery.

As such a system and method for storing and/or mixing a dry medicament component with a wet component for delivery to a user is contemplated herein. The system can include an auto-injector having various chambers therein, wherein the components of the drug are stored separately within the various chambers in various states so as to increase longevity, i.e. a dry drug component in one chamber, and a liquid, such as a solvent, in another. When the auto-injector is needed, the system can be actuated so as to mix the components, thus reconstituting, dissolving, fluidizing, and/or suspending a deliverable mixed drug, wherein the mixed drug can then be properly delivered to a patient. Examples of delivery can include, but are not limited to nebulization for inhalation, injection through a needle or cannula, topical application, etc.

With reference to FIGS. 1-9, shown is an exemplary embodiment of an auto-injector 10 in accordance with a first embodiment. The auto-injector 10 illustrates various aspects of the present invention, each of which will be discussed in more detail below.

Referring to FIGS. 1A-C illustrate perspective views of an auto-injector which illustrates various aspects of the present invention. This embodiment illustrates an auto-injector 10 which has a housing 100 and a cap 14. The cap 14 can be in mechanical communication with a first actuation mechanism contained within the housing 100. By applying an axial torsional force between the cap 14 and the exterior housing, the actuator can cause certain components contained within the housing to initiate certain steps in the mixing process, for example open a valve between the various chambers, and move fluid contained in one chamber into the chamber containing the dry component of the medicament, which steps will be discussed in more detail below.

In certain embodiments, the cap 14 can be configured such that separation of the cap 14 from the housing 100 can be delayed until the device has moved completely from a stowed state to a completely mixed state. In this manner it can be ensured that the needle end of the auto-injector 10 is not exposed until the device is completely ready for delivery. Such mechanisms can include a threaded interface between the cap 14 and the housing 100, or the components can be keyed such that separation is not possible until a certain degree of rotation has been achieved, etc. Once the cap is removed, the injection end of the housing can then be

exposed and a second actuation device triggered so as to inject or otherwise deliver the mixed medicament to a delivery or injection site, for example by depressing the housing up against the delivery site.

In other embodiments, the delivery of the mixed medicament to the injection site can be configured in such a way that the second actuation step cannot be activated until the device has moved completely from a stowed state to a completely mixed state. In this manner it can be ensured that the needle end of the auto-injector **10**, while exposed after removal of cap **14**, cannot be activated until the device is ready. Such embodiments are enabled by features internal to the device, which will be described below. Once mixing is complete, a second actuation device can be triggered so as to inject or otherwise deliver the mixed medicament to a delivery or injection site, for example by depressing the housing up against the delivery site.

FIGS. **2A-B** illustrate an exploded view of an auto-injector **10** in accordance with one embodiment of the present invention. This exploded view illustrates the various internal components within the housing **100** and the cap **14**. The housing can include a pre-loaded energy source **122** which is shown here as a spring, or which can be embodied as a compressed air chamber, which is not shown but could be adapted by those having skill in the art. The spring can be configured to provide a driving force and counter force between an inner plunger shaft **212**, and transferred to various components of a mixing assembly **200** through various stages, as will be discussed below. The mixing assembly **200** can be contained within a frame **110** wherein individual components of the mixing assembly **200** can be configured to selectively rotate within the housing **100**.

The mixing assembly **200** can be retained within the frame using a frame cap **114** which can be formed separately or unitarily with the frame **110**. The frame cap **114** prevents the mixing assembly **200** from pushing through the frame **110** and exiting the housing **100** completely upon injection.

A needle shield **150** and needle shield spring **154** can be provided between the frame **110** and the housing **100** at an injection end of the housing **100**. The needle shield spring **154** can be configured to bias the needle shield **150** axially downward so as to continuously restrict inappropriate exposure of the needle **310** prior to, during, and after injection.

The frame **110** and portions of the mixing assembly **200** can be configured to rotate together within the housing when an axially torsional force is applied between the cap **14** and the housing **100**. The cap **14** can thus be coupled in a radially fixed manner to the frame **110** which is in turn coupled to certain components of the mixing assembly **200**, and a driver interface **118** can also be provided which is rigidly coupled to the housing **100** as well as coupled in a radially fixed manner to alternative portions of the mixing assembly **200** such as to the inner plunger shaft **212**. In this manner the axially torsional force and counter force applied between the cap and the housing can be transferred into and caused to actuate certain components of the mixing assembly **200**.

The mixing assembly can include an inner plunger shaft **212** and an inner plunger **214** which together form a first displacement mechanism. The first displacement mechanism can be configured to reduce the effective volume of the first chamber, which will initially contain the wet solvent or other liquid component of the medicament.

The plunger is configured to interface with an inner vial **210** which forms the first chamber. The inner vial can be housed within a vial sleeve **220**, or alternatively the vial sleeve **220** and the inner vial **210** can be formed unitarily of a single material.

The vial sleeve **220** can then interface with a rotational valve seal **230** which sits within an intermediate support **240**. The intermediate support **240** can have a second displacement mechanism **250**, i.e. a second plunger, which is coupled thereto, the second plunger being configured to reduce the effective volume of a second chamber located within a second vial **270**.

The second vial **270** can then be provided with a delivery assembly **300** affixed thereto which can include a needle **310** or cannula as well as a needle guard **314** or other barrier configured to maintain sterility of the delivery assembly prior to use.

FIGS. **3A-D** and **4A-D** illustrate cross sectional views of the auto-injector **10** and the mixing assembly **200** through various stages of mixing and delivery from a stowed state to a delivered state.

FIGS. **3A** and **4A** specifically illustrate a stowed configuration of the auto-injector **10** and the mixing assembly **200** contained therein. In this state the inner plunger shaft **212** is configured to rest on an upper edge of the inner frame **110** wherein the upper edge of the frame **110** is configured to prevent the pre-loaded energy source from releasing the energy stored therein and causing the plunger shaft **212** to depress and force the inner plunger **214** to move downward and reduce the effective volume of the interior of the inner vial, i.e. first chamber. Fluid communication between the first chamber and the second chamber, which is contained within the second vial **270**, has not yet been established because an outlet of the inner or first vial (not shown here) is not aligned with the fluidic channel **254**.

Dry medication can be kept in a recess **258** formed about an inlet of the second chamber within the second vial **270**, such that fluid passing through the fluidic channel passes through or at least in close proximity to the dry medication stored therein. It will be appreciated that the dry medication can also be stored in the fluidic channel connecting the first and second chambers, or merely kept in any portion of the second chamber wherein a specific recess is not provided.

In this stowed state the second chamber has its effective volume initially reduced to near zero by the second displacement device or plunger **250** so as to further decrease the space occupied by the auto-injector device **10**, which decreased space occupation aides in allowing the device to be incrementally smaller, and thus easier to carry.

In this state the needle **310** and assembly, or other deliver mechanism, is retracted so as to prevent premature injection. The needle **310** is also still within the needle guard **314** so as to preserve sterility until the auto-injector is ready for injection.

It will be appreciated that the cap is not shown in these views for purposes of simplicity, however, the cap can, and will usually be, on for the stowed state.

FIGS. **3B** and **4B** illustrate a second intermediate state wherein the rotary valve is open and fluid communication is established between the first and second chambers just prior to depressing the plunger shaft **212** and the plunger **214**. In this state a rotational force has been applied between the outer housing **100** which retains the driver interface **118** plunger shaft **212**, vial sleeve **220**, inner vial **210** and the valve seal **230** stationary with respect to the housing, then the counter force which is applied to the cap **14** can then be applied so as to twist the frame **110**, and the intermediate support **240** which carries the fluidic channel. This opposing respective rotation between the plunger shaft **212**, inner vial **210**, and the rotational valve seal **230** causes two things to occur simultaneously: First, an outlet of the inner vial is caused to align with an inlet to the fluidic channel thus

## 11

establishing fluidic communication between the inner vial **210** and the second chamber **270**; second, a set of protrusions of the plunger shaft are brought into an axially aligned channel provided in the frame **110** which allows the plunger shaft to be partially driven downward and cause displacement of the fluid contained in the inner vial through the fluidic channel and into the second vial or chamber **270**.

In this embodiment, the respective rotation causes the outlet **224** of the first chamber or inner vial **210** which outlet is formed in the rotational valve seal **230** rotate about a central axis until it is aligned with the inlet fluidic channel **254**. In some embodiments the rotational valve seal **230** can be configured to form the bottom wall of the inner vial **210**, or the inner vial **210** and rotational valve seal **230** can be formed separately and distinctly.

As seen in FIG. 2, the rotational valve seal **230** of this embodiment is keyed having protrusions and channels or apertures corresponding to protrusions and apertures in the vial sleeve such that it remains stationary with respect to the vial sleeve and does not rotate as the cap and intermediate support **240** are rotated so as to allow selective alignment and misalignment between the outlet **224** and the fluidic channel **254**. Alternatively, in embodiments being devoid a specific fluidic channel, alignment between the outlet **224** and an inlet of the second chamber so as to selectively allow or prohibit fluid communication therebetween.

In this state the second chamber still has its effective volume near zero by the second displacement device or plunger **250**. Additionally, in this state the needle **310** or other deliver mechanism and assembly is still retracted so as to prevent premature injection as mixing has not yet occurred. The needle **310** is also still within the needle guard **314** so as to preserve sterility until the auto-injector is ready for injection and the needle shield **150** is still extended to prevent premature injection.

FIGS. 3C and 4C illustrate a mixed state wherein the intermediate support **240** and frame **110** have been rotated with respect to the mixing assembly **200** such that plunger protrusions **216** of the plunger shaft **212** have been aligned with an axially aligned channel of the of the vial sleeve **220** as well as through a channel in a sidewall of the intermediate support **240**.

The axial alignment between the plunger shaft protrusions allows axial translation of the plunger shaft **212** into the inner vial **210**. Once this alignment has been achieved, the plunger shaft **212** is allowed to translate axially downward thus depressing the inner plunger **214** into the inner vial **210** which acts to displace the fluid contained therein through the outlet **224** through the fluidic channel **254** and into the second chamber contained within the second vial **270**. The second vial **270** is permitted to expand its effective volume by being free to translate downward slightly within the frame and housing. As the second chamber expands to receive the fluid being displaced from the first chamber, the fluid passes through or into the recess **258**, which contains the dry medicament, the fluid dissolves the dry component and mixes with the fluid as it enters the second chamber. In another embodiment, the fluid passes into the second chamber **270**, without a recess **258**, and with the powder being located elsewhere in the second chamber **270**. The expanding volume of the second chamber still allows for sufficient mixing with the dry medicament to achieve appropriate mixing.

In the embodiment shown the intermediate support **240** includes similar protrusions resting on an intermediate stop of the frame, and the plunger protrusions of the plunger shaft come to rest on the bottom of the intermediate support

## 12

channel which indicates full depression of the first plunger into the inner vial, which also signifies that mixing is complete and that the device is ready for the injection step.

In this state the needle **310** or other deliver mechanism and assembly is still retracted so as to prevent premature injection as mixing has not yet occurred. The needle **310** is also still within the needle guard **314** so as to preserve sterility until the auto-injector is ready for injection and the needle shield **150** is still extended to prevent premature injection. However, the needle shield **150**, which forms part of a second trigger, is ready to be depressed and thus trigger injection. The functionality of the needle shield **150** will be discussed in greater detail below.

FIGS. 3D and 4D illustrate an injected state wherein the mixing assembly **200** has been rotated another small increment within the housing **100** of the auto-injector **10** such that that protrusions of the plunger shaft **212** as well as additional protrusions, lower intermediate support protrusions **244** as seen in FIGS. 8A-E which will be discussed in more detail below, which are provided on the intermediate support **240** have been rotated around sufficiently so as to align with a second axially aligned channel, **138** as seen in FIGS. 7B-D, of the frame **110**.

Once this alignment has been achieved, a second portion of energy stored within the pre-stored energy source which causes the entire mixing assembly to be pushed downward such that the needle guard **314** comes into contact with the frame cap **114** to stop the needle guard **314** such that the needle **310** punctures needle guard **314** and is extended through the needle guard **314**. The needle **310** then extends further past the needle shield **150**, and the needle **310** is thus extended into or about a delivery site, further as the second vial or chamber **270** hits the bottom portion of the frame cap **114**, the second plunger **250** is depressed into the second vial or chamber **270** reducing its effective volume and causes the fluid to be ejected through the delivery assembly and into the patient or onto the delivery site.

FIGS. 5A-E illustrate perspective views of the mixing assembly **200** within the frame **110** which illustrate various stages of actuation through the mixing and injection process.

In particular, FIG. 5A illustrates the relative position of the mixing assembly **200** with respect to the frame **110** in a stowed state. In this state the plunger shaft **212** is provided with a plurality of plunger protrusions **216** which extend radially outward and rest on an upper lip of the intermediate support **240**. It will be appreciated that the vial sleeve **220** is also provided with a channel through which the plunger protrusions **216** extend and allow for axial translation in later steps of actuation. In this manner the plunger shaft is maintained in a non-depressed or stowed state wherein rotation of the plunger protrusions **216** into the middle support channel **248** must be effectuated before the plunger shaft **212** can translate axially and depress into the vial (not shown) contained within the vial sleeve **220**.

FIGS. 5B-D illustrate the travel of the rotated state of the plunger shaft **212** with respect to the vial sleeve **220** and intermediate support **240**. The plunger protrusions **216** are aligned with the channel **248** and are thus ready for release of a portion of energy contained in the pre-loaded energy source to depress the plunger shaft **212** into the vial sleeve **220** and the vial contained therein (not shown) so as to displace the fluid contained therein. In this embodiment, the rotation of the plunger shaft also causes rotation of the vial sleeve **220**, which rotation causes the outlet of the first chamber to align with the inlet of the fluidic channel leading to the second chamber. In this manner the alignment and thus opening of the fluidic channel occurs simultaneously



with the alignment of the protrusions **216** with the intermediate support channel and allows the pre-loaded energy source to depress the plunger shaft **212**.

FIG. **5C** illustrates an intermediate partially depressed state and FIG. **5D** illustrates a mixed configuration wherein the plunger shaft and plunger have been fully depressed into the first chamber displacing all of the liquid into the second chamber.

FIG. **5E** illustrates a fully mixed state wherein the auto-injector is fully ready for injection. The area A as illustrated in FIG. **5E** will be discussed in further detail wherein the mixing assembly **200**, which includes the intermediate support **240** together with the vial sleeve **220** and plunger shaft **212** all need to rotate a small distance into the frame **110** so as to initiate the injection step.

FIGS. **6A-E** illustrate various perspective detailed and cross sectional views of the area A as defined in FIG. **5E**. As discussed above the frame is provided with a plurality of channels. The first frame channel **130** and the intermediate stop **134** have a pair of upper support protrusions **242** of the intermediate support supported therein. After the mixing stage is complete the protrusions **216** of the plunger shaft **212** are resting on the intermediate support **240** on top of the upper support protrusions **242**.

In order to translate axially downward to eject the fluid through the delivery assembly the intermediate support **240**, vial sleeve **230** and the inner plunger must rotate together so as to be aligned with a second frame channel so as to allow for a second portion of energy to be released from the pre-loaded energy source thus driving the mixing assembly downward, with the delivery assembly affixed to the bottom end thus effectuation injection or delivery. To move from the mixed state and begin injection the upper support protrusions **242** along with the plunger shaft protrusions **216** are rotated radially into a second frame channel **138** as seen best between the positions illustrated in FIG. **6D** to FIG. **6E**.

In particular, FIGS. **6A-B** illustrate perspective exterior and cross sectional views of the interface shown by area A of FIG. **5E** wherein the auto injector and mixing assembly is in a mixed state with the plunger protrusions **216** being depressed against the intermediate support **240** and associated upper support protrusions **242**. All of which rests on the intermediate stop **134** within the first frame channel **130**.

FIGS. **6C-D** illustrate perspective exterior views of the interface shown by area A of FIG. **5E** wherein the auto injector and mixing assembly is in a mixed state but more importantly illustrating an intermediate rotation of the plunger and upper support protrusions **216** and **242** respectively with respect to the frame **110** into an aligned configuration with the second frame channel **138** just prior to injection.

FIG. **6E** illustrates the mixing assembly **200** as it is being further depressed into the frame **110** wherein the plunger shaft **212** and protrusions **216** along with the intermediate support **240** are depressed downward thus driving the delivery assembly (not shown) downward to inject the needle, until the second vial engages the lower end of the frame, stops, and the intermediate support (not shown) then drives the second plunger (not shown) into the second vial displacing the mixed drug out of the delivery assembly and into the delivery site. It is this reason, as described above, that the second actuation, which results in the translation of the mixing assembly downward, can not occur until mixing is complete. The plunger protrusions **216** can not rotate with the upper support protrusions **242** until they are able to rotate together, clear the frame and access the second frame channel **138**. If the user attempts to actuate the second

actuation mechanism prior to plunger protrusions **216** coming into contact with upper support protrusions **242**, the mixing assembly will get stopped from entering the second frame channel **138** by the frame **110**. This mechanism is helpful in preventing the second actuation step from occurring until all of the fluid from the first chamber has been transferred into the second chamber.

FIGS. **7A-D** illustrate various perspective exterior and cross sectional views of the frame **110**. These views illustrate the interior first frame channel **130** and second frame channel **138** with more clarity. These views also illustrate the intermediate stop **134** upon which the upper support protrusions of the intermediate support rests (not shown). In some embodiments the second frame channel **138** can have a tapered channel when effectively increases the width of the second frame channel **138** as the various protrusions travel downward within the second frame channel **138**. This tapering ensures that the various protrusions do not bind up during the injections step, and allow the protrusions to travel freely downward until the second vial hits the stops, signaling full needle extension and driving of the second plunger into the vial thus fully ejecting the mixed fluid and medication compound.

FIGS. **7A-D** also illustrate a safety mechanism in the form of cap rotation locks **112** which interface with an upper portion of the plunger shaft as well as the driver interface such that once the cap is rotated a certain degree, a corresponding protrusion enters into and meshes with the teeth of the cap rotation lock **112** of the frame and prevents the cap from being twisted back. In this manner, if the cap is inadvertently twisted, and a risk of premature mixing is presented by such rotation, a user cannot simply twist the cap back and place the auto-injector back into storage believing that no mixing has occurred. It will be appreciated that, once mixed, even partially, the dry drug will typically begin to degrade at an increased rate. The purpose of the lock is to prevent accidental mixing, or at least signal to the user that the drugs inside might have been previously mixed, wherein instructions on whether or not to use in the case of premature mixing can be provided.

FIGS. **8A-E** illustrate how the needle shield **150** can be configured in one embodiment to act as a bump switch and trigger the injection step by providing the slight rotation of the protrusions **216** and **242** off of the intermediate stop (not shown here) and into the second frame channel discussed above, (not shown). It will be appreciated that this view of the mixing assembly **200** and needle shield **150** are shown herein without the frame so as to better illustrate the interaction of the needle shield **150** with the mixing assembly **200**. However, it will be appreciated that the slight rotation shown here provides the rotation as illustrated in FIGS. **6C-E**.

In the embodiment shown in FIGS. **8A-E** an upward force is applied to the needle shield **150** by depressing the injection end of the auto-injector against the delivery site. In response to this depression force, the needle shield **150** translates upward within the housing and frame such that a lower support protrusion **244** is released from a needle shield hook **158**. The needle shield hook prevents premature rotation of the intermediate support off of the intermediate stop during the changing of states from the stowed state to the mixed state by rotation of the vial sleeve and inner plunger as discussed above, preventing the intermediate support from rotating with those components during mixing and thus preventing premature injection. Additionally, the shield hook can be configured so as to transfer the axially rotational force to be applied to the cap, through the frame,

and into the intermediate support, which allows for relative rotation between the rotational valve seal, as discussed above, and the fluidic channel disposed within the intermediate support so as to allow initial opening of the rotary valve.

As the needle shield **150** translates upward, the lower support protrusions **244** of the intermediate support interface with a needle shield cam ramp **162**. As the needle shield **150** continues to travel upward relative to the intermediate support, the lower support protrusions **244** slide on the needle shield cam ramps **162** and a rotation of the entire mixing assembly **200** is induced as shown in FIG. **8C**. In this embodiment the width of the needle shield cam ramps **162** corresponds with a radial distance required to move the upper support protrusions **242** and the plunger protrusions **216** off of the intermediate stop and into the second frame channel which corresponds to the released configuration as illustrated in FIG. **8D**. Whereupon, as shown by FIG. **8E** the entire mixing assembly **200** can travel downward by force applied from the pre-stored energy source and result in injection or other delivery.

FIGS. **9A-B** illustrate an extension and locking function of the needle shield **150**. It will be understood that it is of general interest to reduce the potential for inadvertent contamination or sticks of other people prior to injection, during injection, and after injection. As such the needle shield **150** of the present embodiment serves both as a bump switch as well as a protective barrier between the user, and other people from inadvertent sticks, jabs, or cuts from an exposed needle. As such, after the bump switch is activated, the needle shield hook, as discussed above, is released and a needle shield spring **154**, as shown in FIG. **2**, or other biasing mechanism, is released so as to push the needle shield outward, or axially downward after activation. The delivery assembly and needle are not ejected until the bump switch is first activated, then after injection, as the user pulls the auto-injector away from the delivery site, the needle shield is simultaneously extended until it clears past the tip of the needle, essentially eliminating the risk of secondary pricks and cross contamination of bodily fluids to other people post injection.

In the embodiment shown the frame cap **114** can be provided with a plurality of protrusions, both lock protrusions **116** for interfacing with one or more needle shield guide channels **166** and needle shield extension lock tabs **170** which interface with the interior of the frame or housing. The guide channels can have space for allowing initial depression whereupon the extension lock protrusions can slide up and then interferingly engage with the lock tabs in a fully extended state after injection. The tabs can prevent pulling the needle shield **150** completely free from the housing as well as prevent a secondary depression of the needle shield **150** which would expose the extended needle.

With reference to FIGS. **10-20**, shown is an alternative exemplary embodiment of an auto-injector **400** in accordance with a second embodiment. The auto-injector **20** illustrates additional aspects of the present invention, each of which will be discussed in more detail below.

Referring to FIGS. **10A-C** illustrate perspective views of an auto-injector **400** which illustrates various aspects of the present invention. This embodiment illustrates an auto-injector **400** which has an exterior housing **402** and a cap **414**. The cap **414** can be in mechanical communication with a first actuation mechanism contained within the exterior housing **402**. Similar to the embodiment discussed previously, by applying an axial torsional force between the cap **414** and the exterior housing **402**, the actuator can cause

certain components contained within the housing to initiate certain steps in the mixing process, for example open a valve between the various chambers, and move fluid contained in one chamber into the chamber containing the dry component of the medicament, which steps will be discussed in more detail below. The relative motion of the various components can be provided through the use of various protrusions which engage with or otherwise interact with cams or channels within the housing.

In certain embodiments, the cap **414** can be configured such that separation of the cap **14** from the housing **402** can be delayed until the device has moved completely from a stowed state to a completely mixed state. In other embodiments the cap can act merely as a contaminant barrier and actuation is effectuated after removing the cap. The embodiment shown illustrates the first, wherein removal of the cap effectuates initiation of, and completion of, the mixing step. In this manner it can be ensured that the needle end of the auto-injector **400** is not exposed until the device is completely ready for delivery.

With regard to the cap **414** and in reference to FIGS. **11A-C**, the Cap **414** can include cam protrusions on an internal portion of the housing or frame which interact with associated cam ramps **416**, wherein the cam ramps **416** allow for release through the keyway **417** after a certain degree of rotation has been achieved. In alternative embodiments, threaded interfaces can be provided between the cap **414** and the housing **400** wherein the axial relative translation of the cap and the housing can effectuate an initiation of the mixing step is also contemplated. However, in each of these embodiments once the cap is removed, the injection end of the housing can then be exposed and a second actuation device triggered so as to inject or otherwise deliver the mixed medicament to a delivery or injection site, for example by depressing the housing up against the delivery site, which acts as a bump switch which in turn initiates injection.

The cap **414** can also include a pair of retaining clips **418** which can interface with a pair of indents on the frame of housing so as to prevent premature rotation of the cap and associated activation of the auto injector.

FIGS. **12A-E** illustrate various exploded views of various internal assemblies within the auto-injector **400** in accordance with one embodiment of the present invention. These exploded views illustrate the various internal components within the housing **402** and the cap **14**. The housing **402** can include a pre-loaded energy source **522** which is shown here as a spring, or which can be embodied as a compressed air chamber, which is not shown but could be adapted by those having skill in the art. The spring can be configured to provide a driving force and counter force between an inner plunger shaft **612**, the driving force being transferred to various components of a mixing assembly **600** through various stages, as will be discussed below. The mixing assembly **600** can be contained within a frame **510** which is can be configured to rotate within the housing **402**.

A needle shield **550** and needle shield spring **554** can be provide between the frame **510** and the housing **402** at an injection end of the housing. The needle shield spring **554** can be configured to bias the needle shield axially downward so as to continuously restrict open and inappropriate exposure of the needle prior to, during, and after injection.

The frame **510** and portions of the mixing assembly **600** can be configured to rotate together within the housing when an axially torsional force is applied between the cap **414** and the housing **402**. The cap **414** can thus be coupled in a radially fixed manner to the frame **510** which is in turn

coupled to certain components of the mixing assembly 600. In this manner the axially torsional force applied between the cap 414 and the housing 510 can be transferred into and caused to actuate certain components of the mixing assembly 600 using actuation means which will be discussed in more detail below.

The mixing assembly 600 can include an inner plunger shaft 612 and an inner plunger 614 which together form a first displacement mechanism which can be configured to reduce the effective volume of the first chamber, which will initially contain the wet solvent or component of the end injectable medicament.

The plunger 614 is configured to interface with an inner vial 610 which forms the first chamber. The inner vial can be housed within a vial sleeve 620, or alternatively, the vial sleeve 620 and the inner vial 610 can be formed unitarily of a single material.

The intermediate support 640 can have a second displacement mechanism 650, i.e. a second plunger, which is coupled thereto, the second plunger being configured to reduce the effective volume of a second chamber located within a second vial 670.

The second vial 670 can have a delivery assembly 700 affixed thereto which can include a needle 710 or cannula as well as a needle guard 714 or other barrier configured to maintain sterility of the delivery assembly prior to use. The needle 710 can be affixed to the second vial 670 using a bonding interface 716, which can be provided as a crimp, adhesive, curing epoxy, or any other number of suitable interfaces.

FIGS. 13A-D illustrate various perspective, side and cross sectional views of the auto-injector 400, with the cap removed, wherein the mixing assembly is maintained in a stowed state prior to initiation.

FIGS. 14A-C illustrate various perspective, side and cross sectional views of a various states of assembly of the auto-injector 400, with the cap or housing removed which illustrates actuation of the first mixing step, wherein rotational motion of the upper portion of the mixing assembly is illustrated prior to the valve being open and energy from the pre-loaded energy source is released. In this state the inner plunger shaft 612 is resting on an upper edge of the inner frame 510 wherein the upper edge of the frame 510 is preventing the pre-loaded energy source from releasing the energy stored therein and causing the plunger shaft from depressing and forcing the inner plunger from moving downward and reducing the effective volume of the interior of the inner vial, i.e. first chamber. Fluid communication between the first chamber and the second chamber within the second vial 670 has not yet been established because an outlet (not shown here) is not aligned with the fluidic channel (not shown).

Dry medication can be kept within the fluidic channel between the two chambers, or alternatively the dry medication can be stored within the second chamber within the second vial 470.

In this state the needle 710 or other deliver mechanism and assembly is retracted so as to prevent premature injection. The needle 710 is also still within the needle guard 714 so as to preserve sterility until the auto-injector is ready for injection.

It will be appreciated that the cap is not shown in these views for purposes of simplicity, however, the cap can and will usually be on for the stowed state.

FIGS. 15A-C specifically illustrate a mixing initiated step wherein a fluidic pathway has been established between the first and second chambers just prior to release of energy

from the pre-loaded energy source to drive the fluid from the first chamber into the second chamber. In this state the rotary valve is open and fluid communication is established between the first and second chambers just prior to depressing the plunger shaft 612 and the plunger, 614 in FIG. 12C. In this state a rotational force has been applied to the outer housing 402 and the cap 414 wherein the force is applied to twist the plunger 614 and plunger shaft 612 inner vial 610 vial sleeve 620 with respect to the housing 100, the frame 510 and intermediate support 640.

This respective rotation causes an alignment of an outlet of the first chamber 610 with a fluidic channel extending into the second chamber 670.

In this state the needle 710 or other deliver mechanism and assembly is still retracted so as to prevent premature injection as mixing has not yet occurred. The needle 710 is also still within the needle guard 714 so as to preserve sterility until the auto-injector is ready for injection and the needle shield 550 is still extended to prevent premature injection.

FIGS. 16A-C and 17A-B illustrate a mixed state wherein the mixing assembly 600 has been rotated sufficiently within the housing such that protrusions, 616 from FIGS. 14A and 15A, of the plunger shaft 612 have been rotated around sufficiently so as to align with an axially aligned channel of the of the vial sleeve 620 as well as through the intermediate support 640, and has translated axially so as to rest on an intermediate stop of the frame. This axial alignment allows axial translation of the plunger shaft 612 into the inner vial 610, which acts to displace the fluid contained therein through the outlet, through the fluidic channel, and into the second chamber contained within the second vial 670 to mix with the dry medicament in the fluidic path.

In this state the needle 710 or other deliver mechanism and assembly is still retracted so as to prevent premature injection as mixing has not yet occurred. The needle 710 is also still within the needle guard 714 so as to preserve sterility until the auto-injector is ready for injection and the needle shield 550 is still extended to prevent premature injection.

However, the needle shield 550, which forms part of a second trigger, is ready to be depressed and thus trigger injection. The functionality of the needle shield 550 will be discussed in greater detail below.

FIGS. 18A-D illustrate various perspective views of a second actuation mechanism of the medication mixing and delivery device as embodied in FIGS. 10A-D illustrating changing from the mixed state to an injected state. This actuator functions similarly to the embodiment discussed above wherein the intermediate support 640 is provided with a protrusion 644 which is rotated incrementally by depressing the needle shield 550. The incremental rotation of the intermediate support 640 causes the plunger protrusions, not shown here, to rotate with the intermediate support 640 and align with a second channel of the housing or frame, and allow for injection to be initiated.

FIGS. 18A-D illustrate a bump switch which operates similarly in function to the embodiments discussed above, however the protrusions of the intermediate support are located in a slightly different configuration, as seen. In particular, the intermediate support does not have an upper protrusion and instead has channels through which the protrusions of the inner plunger can travel through and interface with the intermediate stop, thus allowing the auto-injector to stop in a mixed but non-injected state.

It will be understood that this embodiment also works using a rotational style valve which utilizes selective align-

ment of an outlet **624** of the first chamber **610** with the inlet of the fluidic channel, wherein the selective alignment corresponds with an open configuration when aligned and a closed configuration when misaligned.

FIGS. **19A-B** illustrate an injected state wherein the mixing assembly **600** has been rotated another small increment within the housing **402** of the auto-injector **400** such that that protrusions of the plunger shaft **612** have been rotated around sufficiently so as to align with a second axially aligned channel of the frame **510**, the second channel is not shown herein, but is similar in arrangement to the embodiment previously discussed in particular with reference to FIG. **7A-D**. Once this alignment has been achieved, a second portion of energy stored within the pre-stored energy source which causes the entire mixing assembly to be pushed downward wherein the second vial **670** hits a bottom portion of the frame **510** and frame cap **414** wherein the needle **710** is extended through the needle guard **714** past the needle shield **550** and extended into or about a delivery site, further as the second vial **670** hits the bottom portion of the frame **510** the second plunger **650** is depressed into the second vial **670** reducing its effective volume and causes the fluid to be ejected through the delivery assembly and into the patient or onto the delivery site.

In this state the needle **710** or other deliver mechanism and assembly are extended such that the needle **710** penetrates the needle guard **714** and is extended past the needle shield **750**.

In order to translate axially downward to eject the fluid through the delivery assembly the intermediate support **640**, vial sleeve **630** and the inner plunger **612** must rotate together so as to be aligned with a second frame channel so as to allow for a second portion of energy to be released from the pre-loaded energy source thus driving the mixing assembly downward, with the delivery assembly affixed to the bottom end thus effectuation injection or delivery. To move from the mixed state and begin injection, and as discussed above with reference to FIGS. **18A-D**, the intermediate support can be provided with one or more protrusions **644**, which can be caused to rotate similar to the previously discussed embodiment using cam ramps associated with a bump switch, which the needle shield **550** forms part.

FIGS. **20A-D** illustrate an extension and locking function of the needle shield **550**. It will be understood that it is of general interest to reduce the potential for inadvertent contamination or sticks of other people prior to injection, during injection, and after injection. As such the needle shield **550** of the present embodiment serves both as a bump switch as well as a protective barrier between the user, and other people from inadvertent sticks, jabs, or cuts from an exposed needle. As such, after the bump switch is activated, the needle shield hooks as discussed above are released and a needle shield spring **554** or other biasing mechanism which is configured to push the needle shield outward, or axially downward. The delivery assembly and needle are not ejected until the bump switch is first activated, then after injection, as the user pulls the auto-injector away from the delivery site, the needle shield is simultaneously extended until the needle clears past the tip of the needle, essentially eliminating the risk of secondary pricks and cross contamination of bodily fluids to other people post injection.

In the embodiment shown the housing **402** can be provided with a plurality of protrusions **516** for interfacing with an upper locking edge **566** of the needle shield. Once the needle shield **550** has been extended a certain degree the protrusions **516** engage with the upper locking edge **566** and prevent subsequent depression of the needle shield. The

needle shield hook **558** which previously prevented the premature rotation of the intermediate support can now act as an extension prevention mechanism and can interface with the protrusion **644** of the intermediate support **640** so as to prevent complete removal of the needle shield **550** and thus expose the contaminated needle.

FIGS. **21-24** illustrate various aspects of yet another auto-injector **1010** in accordance with yet another embodiment of the present invention. The auto-injector **1010** can include a housing **1100** which houses a plurality of chambers. The chambers can include a first wet chamber **1210** which can initially contain a wet component for reconstituting, dissolving, and/or suspending a dry medicament. The dry medicament can be contained within a second chamber **1270** or within a fluidic channel **1254** which connects the two chambers, or within a recess formed at an opening or outlet thereof. The orientation of this embodiment includes an intermediate support **1240** which pushes a first plunger **1214** upwards into the first chamber **1210**.

It will be appreciated that, with respect to gasses, most fluids are considered incompressible. In order to facilitate upward motion of the first plunger **1214** and the fluid contained within the first chamber **1210**, a third plunger **1215** and a squeeze chamber **1004** can be provided wherein a compressible gas is provided within the squeeze chamber **1004** or the gas contained therein is permitted to exit the squeeze chamber **1004**. The upward translation of the first plunger **1214** allows it to travel into a portion of the first chamber **1210** which is provided with a fluidic bypass **1255** in the sidewall. In this bypass portion, the fluidic bypass **1255** allows the first chamber **1210** to be compressed and the fluid to travel around the first plunger **1214** through the fluidic bypass **1255** and into and through a fluidic channel **1254** so as to enter into the second chamber **1270** so as to mix with the dry medicament provided within the fluidic channel **1254** or within the second chamber **1270**. In the embodiment shown, the plunger **1214** can be provided with a radially disposed slot on its bottom surface so as to allow fluid to travel from the bypass channel **1255** which is located about the perimeter of the chamber, to the inlet of the fluidic channel **1254** which is located about a central portion.

In this embodiment the intermediate support **1240** can support the second plunger **1250** such that the upward translation of the first plunger **1214** also causes the second chamber **1270** to push away from the second plunger **1250** simultaneously as the first chamber **1210** is compressed so as to expand and accordingly receive the fluid as it travels through the bypass **1255**, through a channel formed in the bottom of the first plunger **1214**, through the fluidic channel **1254**, and into the second chamber **1270**.

FIGS. **21B**, **22A-E**, and **23A-D** illustrate the various stages of the auto injector **1010** and the mixing assembly **1200** from a stowed through the various mixing stages and finally to an injected state.

FIG. **22A** and FIG. **23A** illustrate the auto-injector and mixing subassembly in a stowed state wherein the fluid is in the first chamber **1210**, the first plunger **1214**, intermediate support **1240** and the third plunger **1215** have not been translated upward.

FIG. **22B** and FIG. **23B** illustrate the auto-injector and mixing subassembly in an intermediate state wherein the intermediate support **1240** is beginning to move the first plunger **1214** and the third plunger **1215** upward so as to move the first plunger **1214** into the fluidic bypass portion along the length of the bypass fluidic channel **1255** and wherein the third plunger **1215** is beginning to compress the squeeze chamber **1004**. This position allows the fluid con-

tained in the first chamber 1210 to bypass around the first plunger 1214 through the bypass channel 1255 and through 1214 into the fluidic channel 1254 and into the second chamber 1270 which expands in effective volume as the intermediate support 1240 moves upwards.

FIGS. 22C-D and FIG. 23C illustrate the auto-injector and mixing subassembly in a mixed state wherein the intermediate support 1240 is fully depressed upwards having moved the first plunger 1214 and the third plunger 1215 completely upward so as to fully displace all of the fluid out of the first chamber 1210. In this position the fluid is completely contained in the second chamber 1270 and ready for injection. In this fully injected state the needle is extended through the housing 1100 and into or about a delivery site.

FIG. 22E illustrates the auto-injector and mixing subassembly in a fully injected state wherein the entire mixing assembly is depressed downward and into the second chamber thus displacing the mixed medication and fluid out through the delivery assembly, i.e. the needle.

FIG. 25A-D illustrates yet another embodiment of an auto-injector 1300 which has a first chamber 1410 containing a fluid component therein and a second chamber 1470 containing a dry medicament component. The auto-injector 1300 can have a movable body 1450 which has a fluidic channel 1454 provided therethrough. In one embodiment the fluidic channel can contain the dry medicament component. In another embodiment the dry medicament component can be placed just upstream from the fluidic channel. In order to displace the fluid within the first chamber 1410 into the second chamber 1470.

In one embodiment an initial tensile force can be applied at two ends of the housing so as to be pulled or telescoped axially apart thus causing a first telescoping effect which causes the movable body 1450 to be displaced upwards into the first chamber 1410 and force the fluid from the first chamber 1410, through the fluidic channel 1454 and into the second chamber 1470. This motion of the movable body upwards causes the second chamber 1470 to simultaneously expand so as to facilitate in the receipt of the fluid being displaced and thus facilitate mixing of the fluid with a dry medicament stored either within the fluidic channel 1454 or within the second chamber 1470. Once the fluid and the dry medicament are fully mixed the device can be pulled or telescoped axially apart further, which telescoping causes a pin 1314 disposed within the housing 1310 to pull away from a lock mechanism 1304, wherein a trigger device causes protrusions of the locking mechanism to translate radially inward and release through a hole, wherein translation was previously restricted by the pin 1314, wherein the trigger also allows a pre-loaded energy source 1322, i.e. a spring to be released, and push the entire mixing assembly 1350 in an axial direction toward the needle assembly. This trigger device can also be provided as a bump switch or needle guard depression switch similar to those disclosed with reference to the embodiments disclosed above. Once the needle is extended from the housing a bottom portion of the second chamber 1470 will engage the housing 1310 and cause the movable body 1450 to displace the fluid in the second chamber 1470 out through the needle 1490 and into the delivery site.

FIG. 24 illustrates a perspective exploded view of the embodiment of the auto-injector 1010 of FIGS. 21-23, which better illustrate the assembly and how many of the individual components interact with one another. A housing 1100 can contain the mixing assembly 1200, wherein the mixing assembly 1200 can be retained within the frame 1100 by the needle guard 1110 on an injection end and by a

retention clip 1119 and pull trigger 1118 on an opposing distal end. The mixing assembly 1200 can include up inner vial 1210 and an intermediate support 1240 wherein the extension of the pull trigger 1118 causes the cam ring 1117 to rotate and allow the mixing spring 1123 to discharge a torsional and axial force stored therein so as to rotate the middle stopper 1117. Rotation of the cam ring 1117 is configured to cause the intermediate support 1240 to translate upward into the inner vial 1210, open fluidic communication, and displace the fluid contained therein into the second vial 1270. It will be appreciated that cam ring 1117 and intermediate support 1240 can be separate components for purposes of assembly, or alternatively they can be unitarily formed. Then upon depressing the needle guard 1110 into the housing 1100 the main spring 1122 is discharged and the entire mixing assembly 1200 is forced downward extending a needle (not shown) through the housing. The fluid, which is now contained in vial 1270, is then displaced through the needle contained in sterility barrier 1114. It will be appreciated that sterility barrier 1114 can be configured to be removed prior to use, or penetrated during injection just prior to delivery of the mixed fluid. Once injection is completed the needle guard spring 1154 can bias the needle guard 1110 outward into an extended and locked position so as to protect inadvertent sticks by the now extended needle.

FIGS. 26A-B illustrate the principles of operation of a rotary valve 800 for use in the embodiments discussed above. A rotary valve can be formed wherein a fluidic pathway is established by rotating one aperture with another. In this exemplary illustration the aperture 804 can be provided in a bottom portion of a vial which forms a top interfacing portion 802 forming a chamber and the secondary aperture 814 provided through a bottom interfacing portion of the seal 810, which can be the inlet to the remaining portion of a fluidic channel leading to another chamber. FIG. 26A illustrates a closed configuration wherein the two apertures are misaligned and fluid communication does not exist. FIG. 26B illustrates an open configuration wherein the two apertures are aligned and fluid communication is established. It will be appreciated that in order to form a better seal, one or both of the components can be formed of a material having elastic properties such as rubber or silicone. In another embodiment, one of the components is rubber and another is hard plastic. In another embodiment each of the sealing surfaces are made up of a combination of hard plastic and elastomeric materials in one interface.

FIGS. 27A-D illustrate an alternative valve mixing assembly 900 which is effectuated by means of sliding two components axially with respect to one another so as to effectuate establishment of fluidic communication, rather than through rotation.

FIG. 27A illustrates a stowed state wherein fluid is contained in a first vial 910 by a first plunger 940, wherein the first vial 910 has an outlet 914 which is misaligned with the fluidic channel inlet 952 of the fluidic channel 950 in an axial direction, wherein the fluidic channel 950 provides fluidic communication with the second vial 920. The fluidic channel 950 is disposed in an intermediate body 930 which can double as a second plunger for the second vial. Mixing can be initiated through various cams or axially forces applied to the mixing system which cause a relative axial translation between the first vial 910 and the intermediate support 930 so as to align the outlet 914 with the fluidic channel inlet 952. The intermediate support can then be caused to translate axially with respect to the intermediate support simultaneously as the first plunger 940 is depressed

into the first vial **910** until all of the fluid has been received in the second chamber **920** and completely displaced from the first chamber **910**. Then both the first plunger and the intermediate support can be simultaneously depressed so as to displace the fluid out of the needle **960** which simultaneous depression can cause the needle to penetrate the needle guard **970**. It will be appreciated that axial translation can be achieved by translating rotational motion using ramped cam systems and corresponding protrusions, various spring mechanisms in different configurations all of which will be within the scope of the present invention and will also be within the understanding of one of ordinary skill in the art having possession of this disclosure.

For purposes of the sliding valve of FIGS. **27A-D** it will be appreciated that various effectuation means can be effectuated by various protrusions such as on the vial sleeve which can translate within channels provided in adjacent components so as to effectuate the axial translation of the first chamber, and its associated outlet, with the inlet of the fluidic channel.

FIGS. **28A-C** illustrate yet another mixing assembly **1500** adaptable for use in one or more of the auto-injectors above. This alternative valve mixing assembly **1500** is effectuated by displacing a first chamber **1510** with respect to an initially stationary plunger **1514**, the outer surface of the first chamber **1510** can be provided with a seal and function as a plunger for a second chamber **1570**. By displacing the first chamber **1510** upward, a fluid contained therein can travel through an aperture or valve **1518** so as to be displaced into the second chamber **1570**, which can contain the dry medicament therein, or the dry medicament can be stored in the fluidic channel, wherein the upward motion of the first chamber automatically expands in response to the upward motion of the first vial **1510**. The second vial **1570** can be held stationary, or be provided with independent protrusions which cause it to not be drawn upward at all, or at least not be drawn upward at the same rate as the first vial **1510** so as to facilitate proper expansion in response to the volume of fluid moving from the first chamber into the second chamber. Once mixing is complete the plunger **1514** as well as the rest of the assembly can be forced downward so as to facilitate injection. For purposes of illustration, a spring could be configured to act on the plunger after mixing is complete and provide a compressive force of the mixing assembly **1500** between the spring and an outer housing in which the mixing assembly resides so as to displace the fluid from the second chamber and out of the needle **1590**, which is effectuated by means of sliding two components axially with respect to one another so as to effectuate establishment of fluidic communication, rather than through rotation.

FIGS. **29-30** illustrate various intermediate bodies **850** and **850A** having fluidic channels **852** disposed therein. The fluidic channel **852** can have an inlet **854** for receiving a fluid and allowing the fluid to pass therethrough. In some embodiments a secondary fluidic body **860** having a secondary fluidic channel **856** can be provided which receives the fluid, the secondary fluidic body can introduce additional flow features so as to affect flow therethrough. In the embodiment shown the secondary body can be provided with a plurality of turbulence features which induce turbulent flow and increase flow speed, pressure differential, and can increase the effectiveness of mixing between the fluid and a dry medicament which can be stored therein. In another embodiment the dry medicament can be stored in **854**.

FIG. **30** illustrates an alternative intermediate body **850A** with a recess configured to receive a customizable ferrule

**862**. The ferrule can have an enlarged interior portion configured to receive an amount of dry medicament wherein a selection of ferrules can be provided having greater or smaller interior portions for adjusting the dosage of medicament for a particular end user. It will be appreciated that the intermediate bodies of these respective embodiments can be oriented in any fashion such that the inlets or outlets are switched or such that the ferrule is at either an inlet or outlet of its respective intermediate body.

FIG. **31A** illustrates additional embodiments of secondary fluidic bodies **860A** and **860B** which can introduce additional bends and passes to the various fluidic pathways **856A-B**.

FIG. **31B** illustrates a detailed perspective cross sectional view of a fluidic channel **856** and respective turbulence inducing features **857**.

FIGS. **32A-C** illustrates a fluidic channel assembly **870** which can be adapted for use with any of the embodiments discussed above. The fluidic channel assembly **870** can include a dosage ferrule **872**, which in one embodiment contains dry powder medicament, a channel sleeve **875** and a fluidic channel **876**. A fluidic channel insert **874** for use in the fluidic channel assembly **870** can be formed by coupling two separate plates **878** and **880** which are machined to form a gap when pressed together thus forming the fluidic channel **876**. By forming the fluidic channel between two separate plates, more complex internal features **882** can be formed prior to assembly. It will be appreciated that the two plates can be bonded in any suitable manner such as welding, adhesive, etc. The channel sleeve can then be provided so as to ensure a seal and reduce leakage. This fluidic channel insert **870** can be adapted for use with any of the embodiments discussed above.

FIGS. **33A-B** illustrate yet another embodiment of a proposed fluidic channel assembly **630A**. This fluidic channel assembly **630A** can be formed of a seal component **632A** which directs fluid received from an upper portion into a desired entry point on a fluidic channel component **634A**. In one embodiment, a dry powder medicament can be stored in the pocket recess in **632A**. In another embodiment, a dry powder medicament can be stored in the fluidic channels **636** and **638**. Various fluidic channel designs **636** and features **638** can be formed into an upper surface of the fluidic channel component **634A** in virtually any suitable configuration through various machining means, laser, acid etching, injection molding, or embossing or any other suitable process so as to form a desired channel configuration **636** or features **638**. The channels can ensure proper fluid dispersion, induce turbulence, or provide any other number of desired flow characteristics of the fluid passing there-through.

It will be further understood by those in possession of this disclosure that the chambers and respective plungers can be movable with respect to one another. As such, in some cases, and as shown here, translating the plunger into the vial which forms the respective chamber can be one method of reducing the effective volume and displacing fluid contained therein. In other embodiments the vials themselves can be displaced onto, or with respect to, a stationary plunger so as to provide the displacement force. In yet other embodiments a combination of the two can be utilized so as to provide the displacement effect.

FIGS. **34A-B** illustrate an injection or delivery assembly **1600** adaptable for use with any of the auto-injectors discussed above. FIG. **34A** illustrates an exemplary mixing assembly **1650**, similar to any of the mixing assemblies disclosed herein, the mixing assembly **1650** having an

expanded second chamber **1670** containing the mixed drug and liquid component just prior to injection. A septum **1612** is provided between the inlet end of the needle **1610** and separates the interior channel or cannula of the needle from introducing contaminants therethrough into the second chamber **1670** prior to injection. Additionally septum separates the needle from the interior of the second chamber so as to prevent premature leaking and full mixing of the various components prior to actuation and injection.

It will be appreciated that the needle has both a distal or injection end and a proximal end. The distal end can be configured to enter into a patient at an injection site and the proximal or inlet end being configured to pierce and ultimately penetrate the septum. It will be further appreciated that in FIG. **34A** the needle **1610** has still not yet penetrated the septum **1612**.

As shown in FIG. **34A**, the needle **1610** can be partially embedded into, but not fully penetrated through, the septum **1612** in a stowed state wherein the needle **1610** can penetrate the septum **1612** and open fluid communication out the injection end just prior to injection.

In order to provide penetration of the septum **1612** by the needle **1610**, the needle can be carried by a translating needle carrier **1620**. The needle carrier **1620** can have a translating body which is allowed to translate axially along the needle axis with respect to the second chamber **1670** and the septum **1612**. The degree of translation can be limited or controlled by providing abutting shoulders which interfere with one another at certain points along the relative travel distance between the carrier and the second chamber. In one instance the shoulders can engage to prevent the needle from being released from the system and sliding out of the auto injector entirely, and in another instance the shoulders can engage to provide the axial translation and puncture force of the needle through the septum when pushed down just prior to injection. In the cross sectional view of FIG. **34A** the needle carrier is extended to its maximum distance away from the second chamber.

FIG. **34B** illustrates the injection motion of pressing the auto injector up to an injection site. The downward force drives the needle **1610** downward with respect to the needle shield to expose the needle from the interior of the auto injector body. A shoulder or stop can be provided on the interior of the needle shield which engages with the needle carrier and pushes the proximal end of the needle through to fully penetrate through the septum. At this point a fluid pathway is established and fluid communication is provided from the second chamber into the patient's body or other

injection site. At this point a second plunger can be pushed into the second chamber thus forcing the mixed drug into the injection site.

While the principles of the invention have been described herein, it is to be understood by those skilled in the art that this description is made only by way of example and not as a limitation as to the scope of the invention. Other embodiments are contemplated within the scope of the present invention in addition to the exemplary embodiments shown and described herein. Modifications and substitutions by one of ordinary skill in the art are considered to be within the scope of the present invention.

We claim:

1. A medication mixing and delivery device, the device comprising:

a housing;

a first chamber located within the housing, the first chamber containing a first medicament component;

a second chamber located within the housing, the second chamber configured to selectively receive the first medicament component from the first chamber;

a valve located within the housing, the valve configured to provide selective fluidic communication between the first chamber and the second chamber;

a first displacement mechanism configured to reduce an effective volume of the first chamber and axially translate the second chamber with respect to the first chamber during a first actuation, wherein the first displacement mechanism is comprised of at least one radial protrusion configured to engage a channel formed in an intermediate support that is disposed in the housing, wherein the channel has a first portion, a second portion, and an intermediate stop disposed between the first and the second portions;

a second displacement mechanism configured to reduce an effective volume of the second chamber;

a second medicament component stored within the housing and outside the first chamber;

a second trigger which is mechanically coupled to the at least one radial protrusion, wherein triggering the second trigger causes the at least one radial protrusion to engage with the second portion of the channel;

wherein an actuation device is in mechanical communication with the valve, the actuation device being configured to change the valve between a closed state and an open state during the first actuation; and

wherein the first actuation moves the at least one radial protrusion relative to the first portion of the channel.

\* \* \* \* \*