



US009912464B2

(12) **United States Patent**
Jin et al.

(10) **Patent No.:** **US 9,912,464 B2**
(45) **Date of Patent:** **Mar. 6, 2018**

(54) **INTERFERENCE RELATIONSHIP CHARACTERIZATION IN FULL DUPLEX CABLE NETWORK ENVIRONMENTS**

(71) Applicant: **CISCO TECHNOLOGY, INC.**, San Jose, CA (US)

(72) Inventors: **Hang Jin**, Plano, TX (US); **John T. Chapman**, Coto de Caza, CA (US)

(73) Assignee: **Cisco Technology, Inc.**, San Jose, CA (US)

(*) Notice: Subject to any disclaimer, the term of this patent is extended or adjusted under 35 U.S.C. 154(b) by 152 days.

(21) Appl. No.: **15/052,542**

(22) Filed: **Feb. 24, 2016**

(65) **Prior Publication Data**
US 2017/0019242 A1 Jan. 19, 2017

Related U.S. Application Data

(60) Provisional application No. 62/192,924, filed on Jul. 15, 2015.

(51) **Int. Cl.**
H04L 5/14 (2006.01)
H04B 3/20 (2006.01)
H04L 12/28 (2006.01)

(52) **U.S. Cl.**
CPC **H04L 5/1461** (2013.01); **H04B 3/20** (2013.01); **H04L 12/2801** (2013.01)

(58) **Field of Classification Search**
CPC H04L 12/6456; H04L 5/1461; H04L 12/2801; H04L 25/08; H04L 25/085;
(Continued)

(56) **References Cited**

U.S. PATENT DOCUMENTS

6,725,462 B1 * 4/2004 Kaplan H04J 1/12 348/E7.07

6,912,209 B1 6/2005 Thi et al.
(Continued)

FOREIGN PATENT DOCUMENTS

EP 0182096 A2 5/1986
EP 0936781 A1 8/1999

(Continued)

OTHER PUBLICATIONS

PCT Sep. 22, 2016 International Search Report and Written Opinion of the International Searching Authority from International Application PCT/US/2016/038269.

(Continued)

Primary Examiner — Robert M Morlan
(74) *Attorney, Agent, or Firm* — Merchant & Gould P.C.

(57) **ABSTRACT**

An example method for characterizing interference relationships in full duplex cable network environments is provided and includes generating a global interfered list for a plurality of cable modems in the cable network and for a plurality of frequency ranges, generating a global interfering list for the plurality of cable modems and for the plurality of frequency ranges, assigning respective downstream reception frequency ranges and upstream transmission frequency ranges for the plurality of cable modems based on the global interfered list and the global interfering list, and transmitting to the cable modems corresponding assignment information comprising the respective assigned downstream reception frequency ranges and upstream transmission frequency ranges.

20 Claims, 26 Drawing Sheets

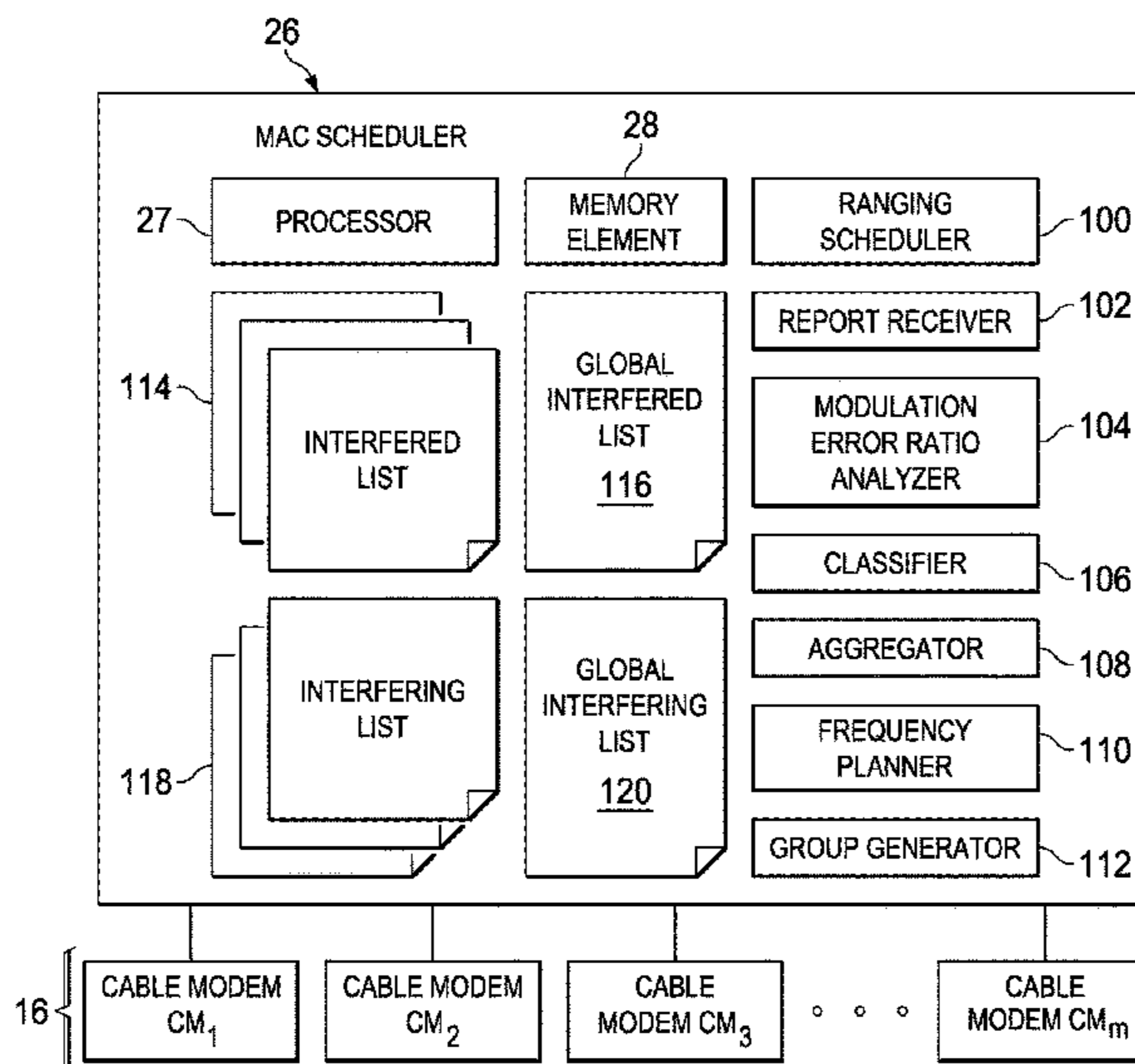

(58) **Field of Classification Search**

CPC H04L 47/829; H04L 47/78; H04L 47/781;
H04L 47/782; H04L 47/783; H04L
47/785; H04L 47/786; H04L 47/787;
H04L 47/788

See application file for complete search history.

(56) **References Cited**

U.S. PATENT DOCUMENTS

7,856,049 B2 * 12/2010 Currivan H04B 1/71
375/222

8,457,584 B2 6/2013 Currivan

8,565,266 B1 10/2013 Fox et al.

8,594,118 B2 11/2013 Cooper et al.

9,031,409 B2 5/2015 Nandiraju et al.

8,937,992 B2 6/2015 Cooper et al.

9,136,943 B2 9/2015 Thompson et al.

9,160,463 B2 10/2015 Hunter

9,172,429 B2 * 10/2015 Gerszberg H04B 3/54

9,775,116 B2 * 9/2017 Abdelmonem H04W 52/241

2002/0032004 A1 3/2002 Widrow

2006/0262722 A1 11/2006 Chapman et al.

2011/0149764 A1 * 6/2011 Wiefeldt H04W 88/06
370/252

2011/0170473 A1 7/2011 Proctor, Jr. et al.

2012/0269242 A1 10/2012 Prodan et al.

2012/0275792 A1 11/2012 Nandiraju et al.

2013/0101116 A1 4/2013 Ross et al.

2013/0114480 A1 5/2013 Chapman et al.

2013/0194984 A1 8/2013 Cheng et al.

2013/0332978 A1 12/2013 Rakib

2014/0010269 A1 1/2014 Ling et al.

2014/0022926 A1 1/2014 Ling et al.

2014/0022943 A1 1/2014 Ling et al.

2014/0133352 A1 5/2014 Chapman et al.

2015/0082363 A1 3/2015 Gomez et al.

2015/0188653 A1 7/2015 Hanks et al.

2015/0188668 A1 7/2015 Al-Banna

2015/0257165 A1 * 9/2015 Gale H04B 1/1036
370/329

2015/0382361 A1 * 12/2015 Sabapathi H04W 72/082
370/329

2017/0019146 A1 1/2017 Jin et al.

2017/0019239 A1 1/2017 Jin et al.

2017/0019241 A1 1/2017 Jin et al.

2017/0033915 A1 2/2017 McCoy et al.

2017/0085398 A1 3/2017 Liu

2017/0104506 A1 4/2017 Liu et al.

2017/0244445 A1 8/2017 Jin et al.

FOREIGN PATENT DOCUMENTS

EP 1374511 B1 1/2004

EP 1429470 A2 6/2004

EP 1705824 9/2006

EP 2879301 A1 6/2015

WO WO 2013/095386 6/2013

WO WO 2013/126297 8/2013

WO 2015021461 A1 2/2015

WO WO 2015/162104 10/2015

WO 2016033266 A1 3/2016

WO 2017011146 A1 1/2017

WO WO 2017/011142 1/2017

WO WO 2017/011143 1/2017

WO WO 2017/011144 1/2017

OTHER PUBLICATIONS

PCT Sep. 30, 2016 International Search Report and Written Opinion of the International Searching Authority from International Application PCT/US/2016/038272.

PCT Oct. 17, 2016 International Search Report and Written Opinion of the International Searching Authority from International Application PCT/US/2016/038268; 12 pages.

PCT Dec. 6, 2016 International Search Report and Written Opinion of the International Searching Authority from International Application PCT/US/2016; 17 pages.

U.S. Office Action dated Jul. 20, 2017 cited in U.S. Appl. No. 15/052,428, 22 pgs.

U.S. Office Action dated Aug. 10, 2017 cited in U.S. Appl. No. 15/052,499, 13 pgs.

U.S. Appl. No. 15/052,428, filed Feb. 24, 2016, 2016, entitled "Full Duplex Network Architecture in Cable Network Environments," Inventors: Hang Jin, et al.

U.S. Appl. No. 15/052,466, filed Feb. 24, 2016, entitled "Scheduling Mechanisms in Full Duplex Cable Network Environments," Inventors: Hang Jin, et al.

U.S. Appl. No. 15/052,499, filed Feb. 24, 2016, entitled "Interference Suppression in Full Duplex Cable Network Environments," Inventors: Hang Jin, et al.

Schnoor, Jon, et al., "Leveraging Full Band RF Capture to Improve the Customer Experience and Operational Performance", ubeeinteractive, White Paper, First Published on or about Jan. 5, 2015, 22 pages.

European Office Action dated Nov. 7, 2017 cited in Application No. 17167831.1, 7 pgs.

European Combined Search and Examination Report dated Nov. 24, 2017 cited in Application No. GB1708266.0, 7 pgs.

U.S. Office Action dated Dec. 14, 2017 cited in U.S. Appl. No. 15/052,466, 38 pgs.

* cited by examiner

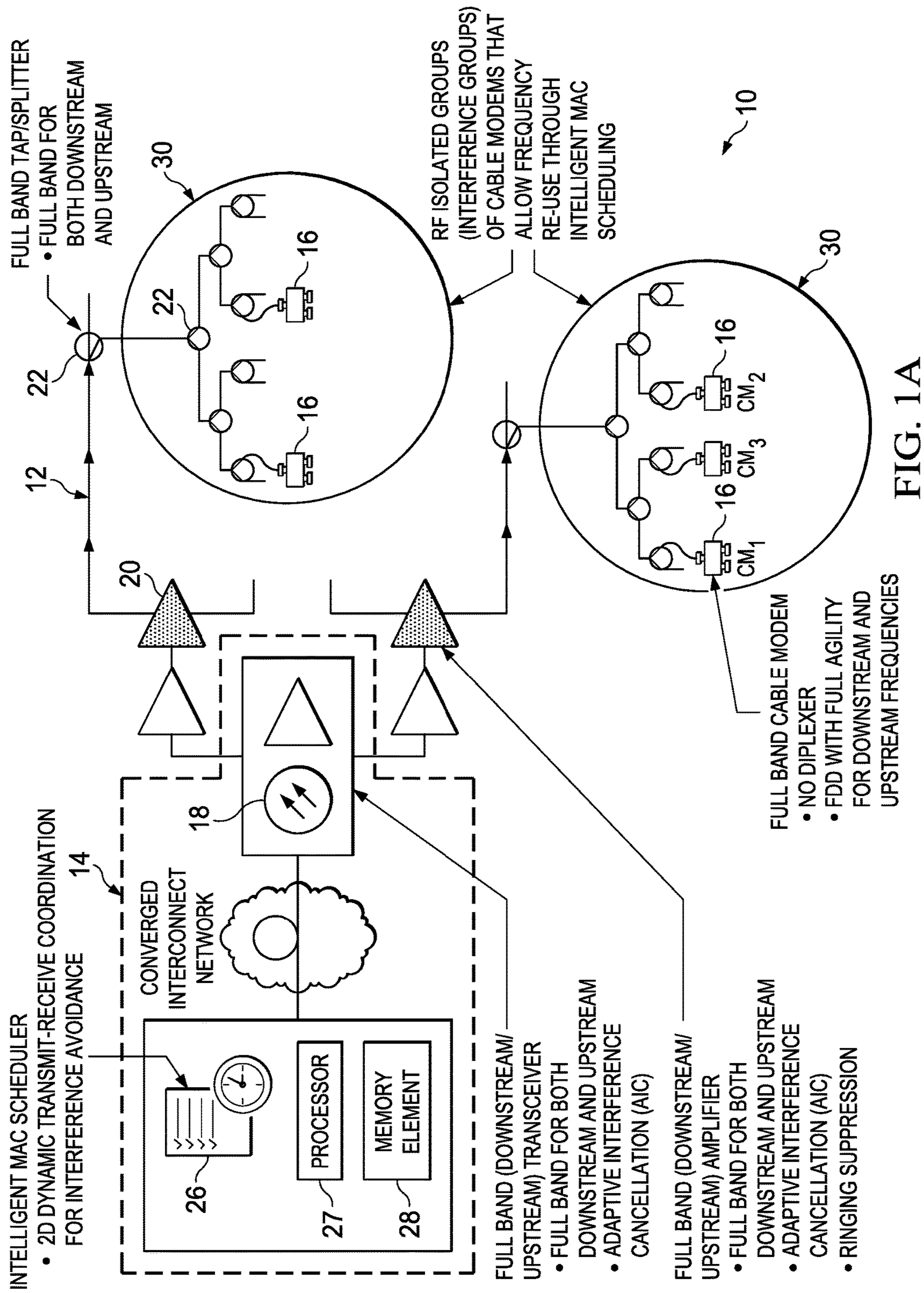

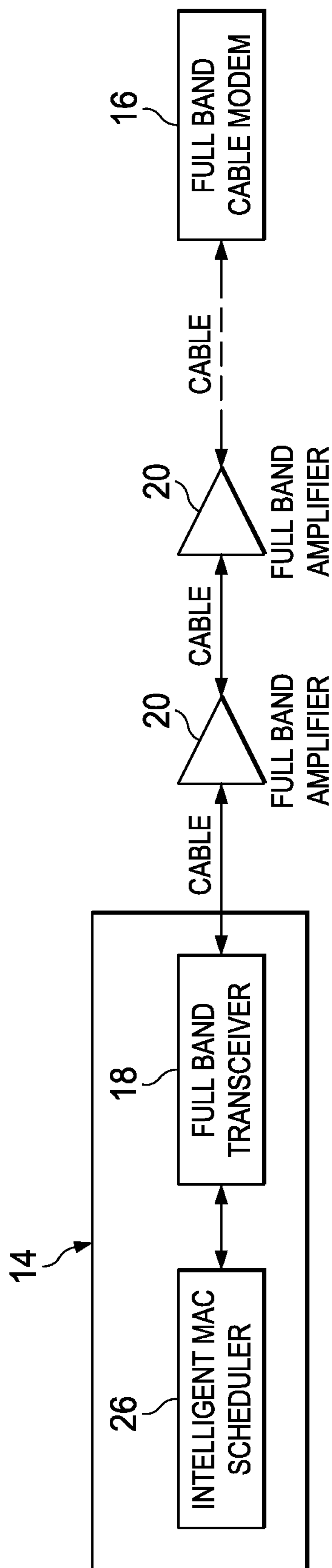

FIG. 1B

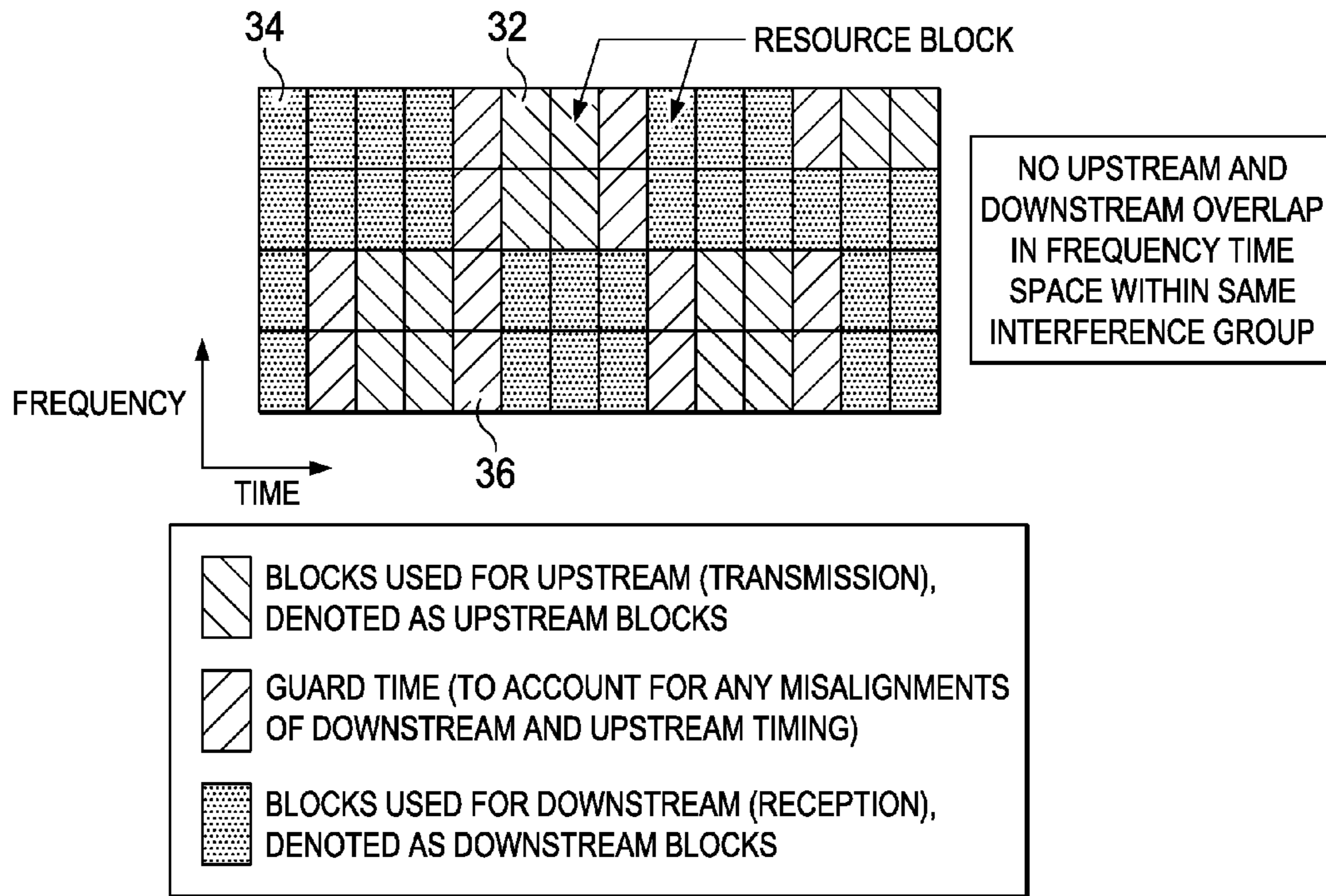
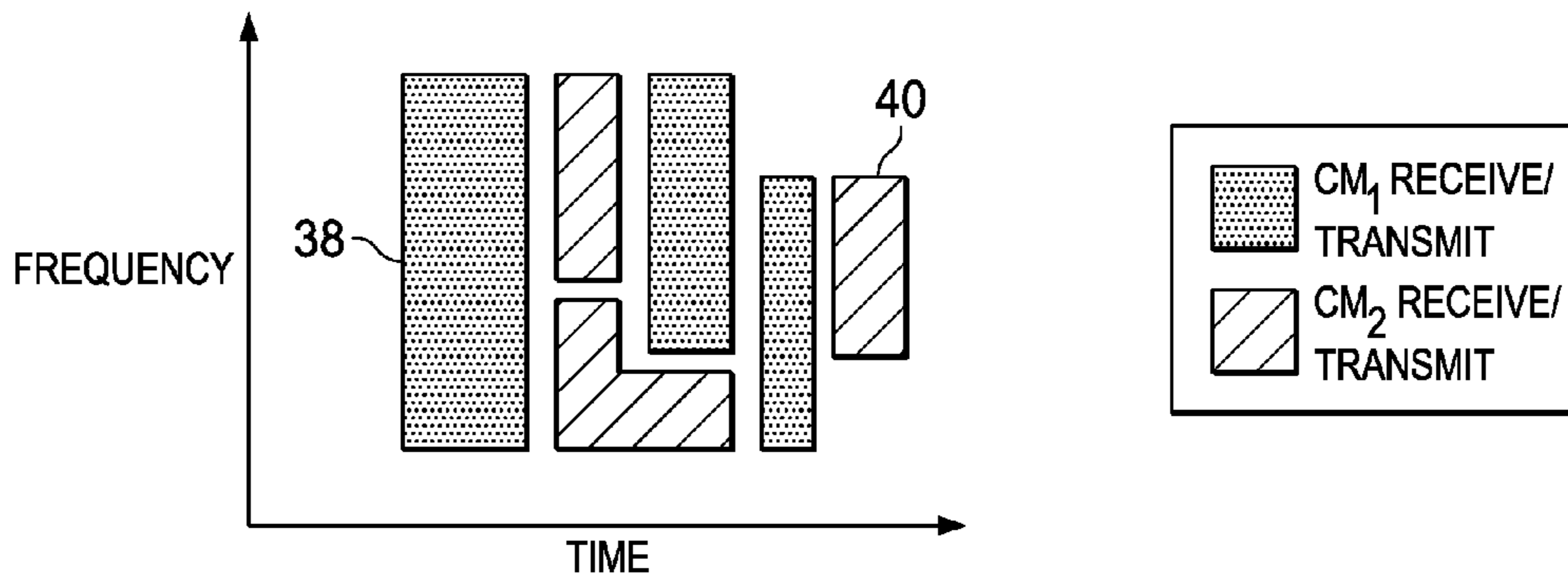

FIG. 2



- CM₁ AND CM₂ BELONG TO THE SAME INTERFERENCE GROUP
- THE INTELLIGENT MAC SCHEDULER WILL NOT SCHEDULE CM₂ TO TRANSMIT ON THE SAME FREQUENCY AND AT THE SAME TIME WHEN CM₁ IS RECEIVING

FIG. 3

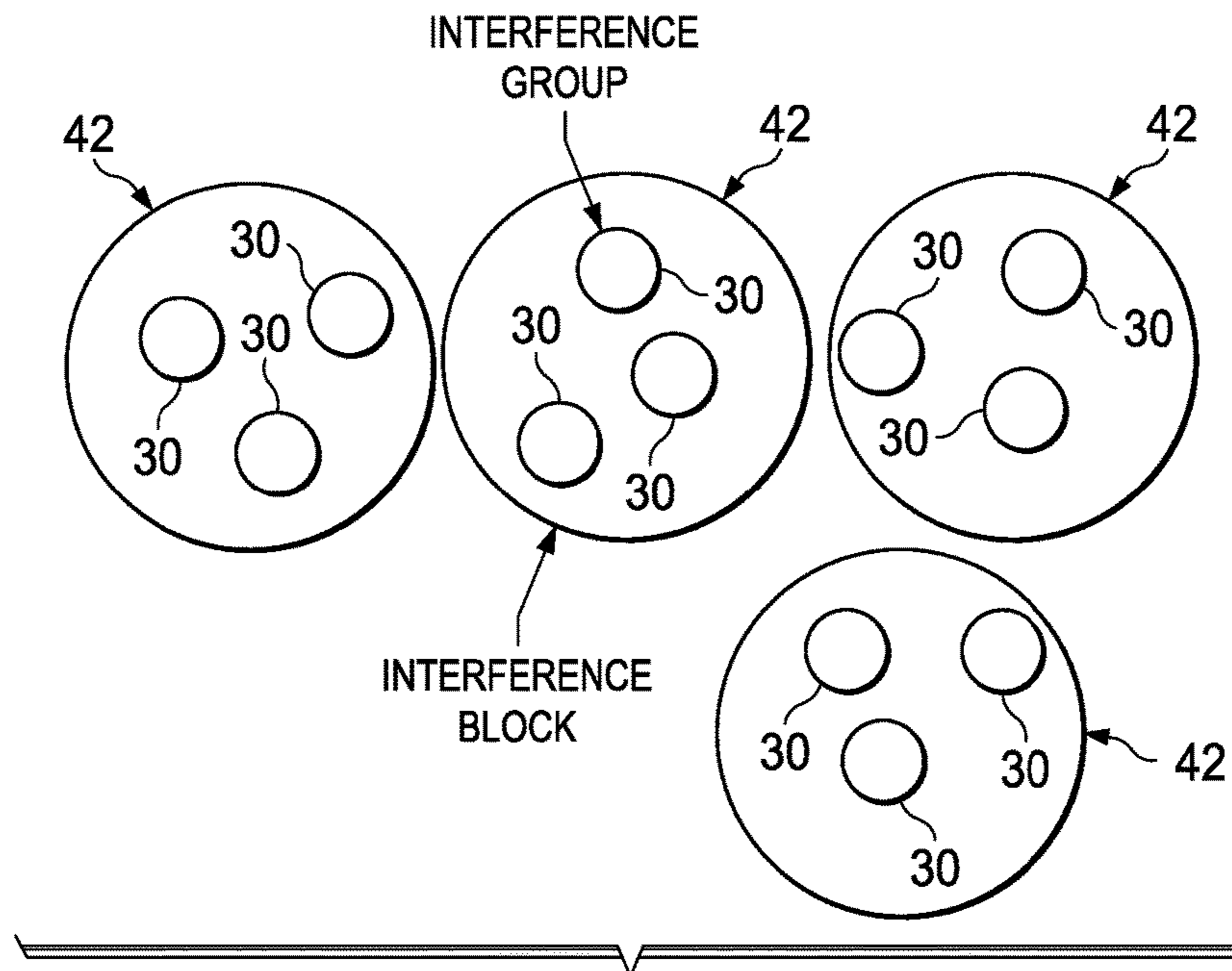

FIG. 4

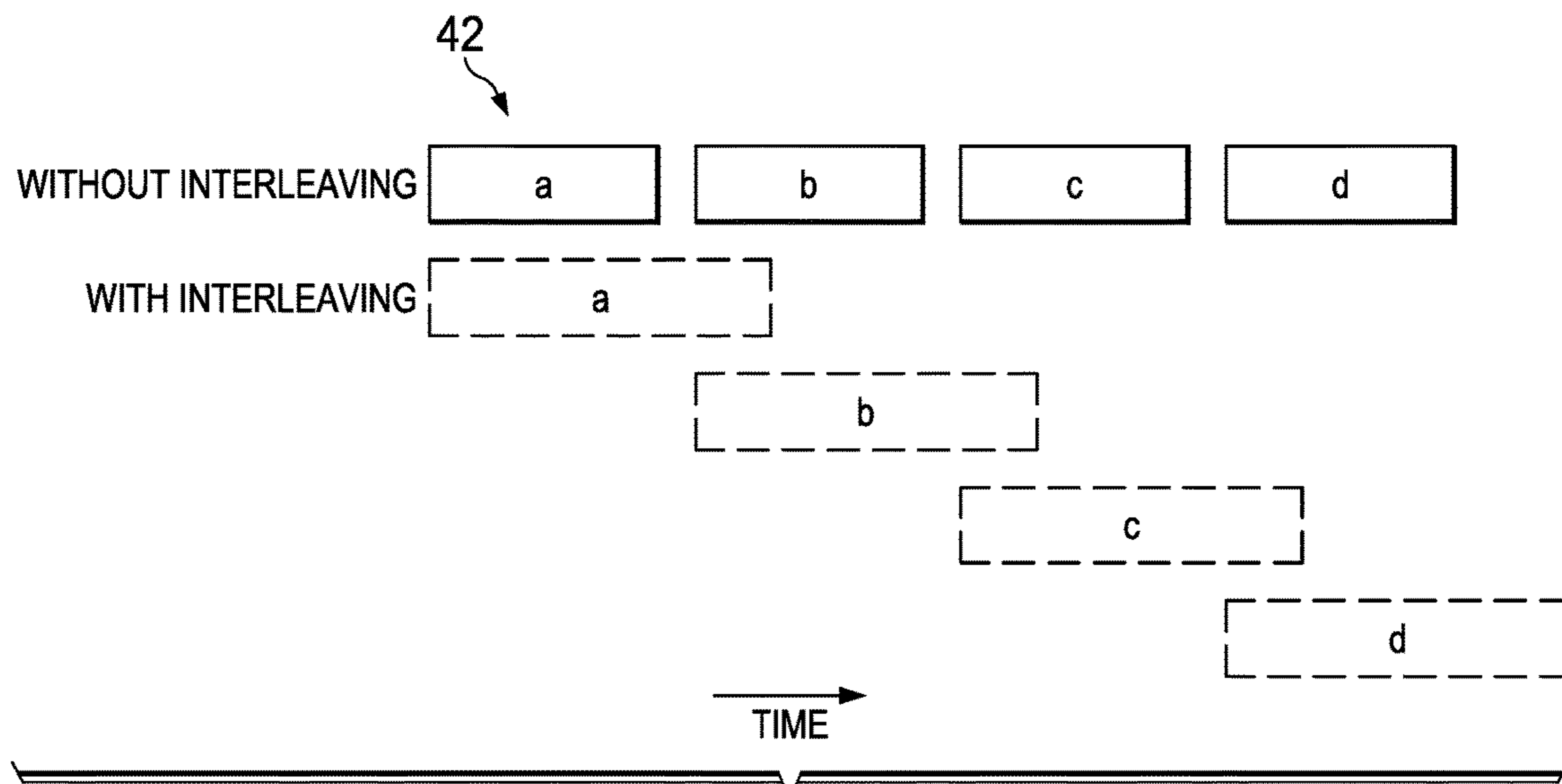
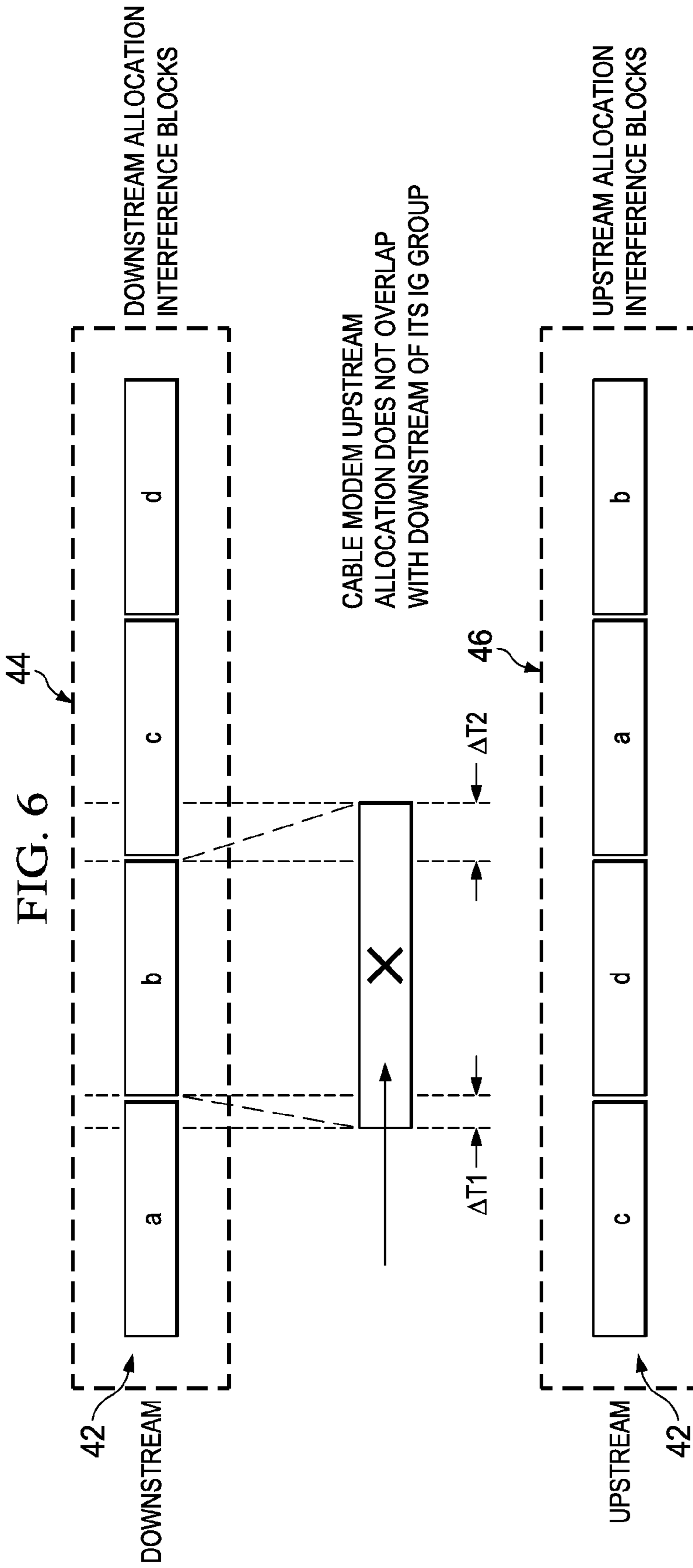

FIG. 5



$\Delta T1$, $\Delta T2$ ARE THE GUARD TIMES TO ACCOUNT FOR DELAYS AMONG CABLE MODEMS, THE DELAY BETWEEN CABLE MODEM TERMINATION SYSTEM AND CABLE MODEMS, AND THE TIME INTERLEAVING

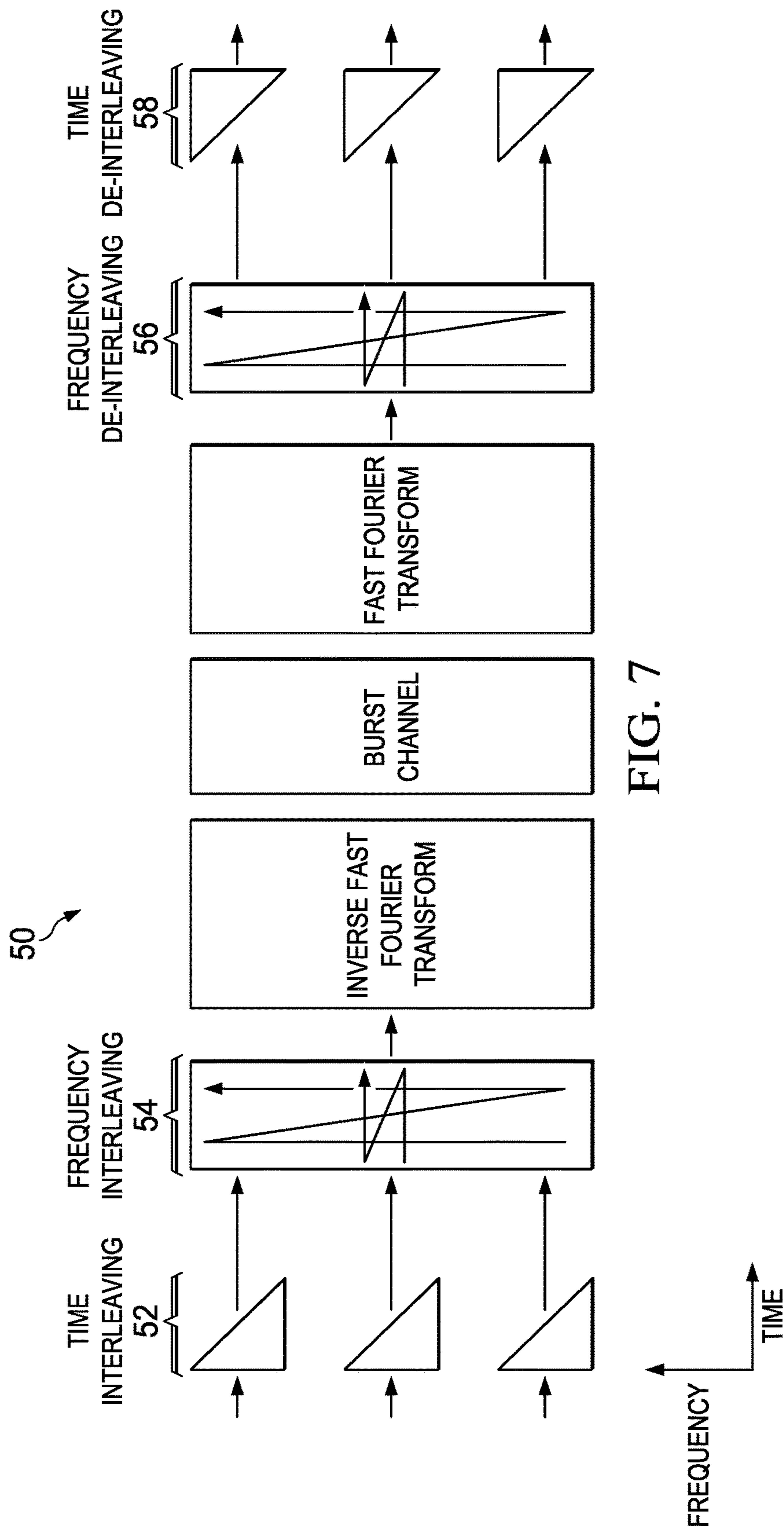

FIG. 7

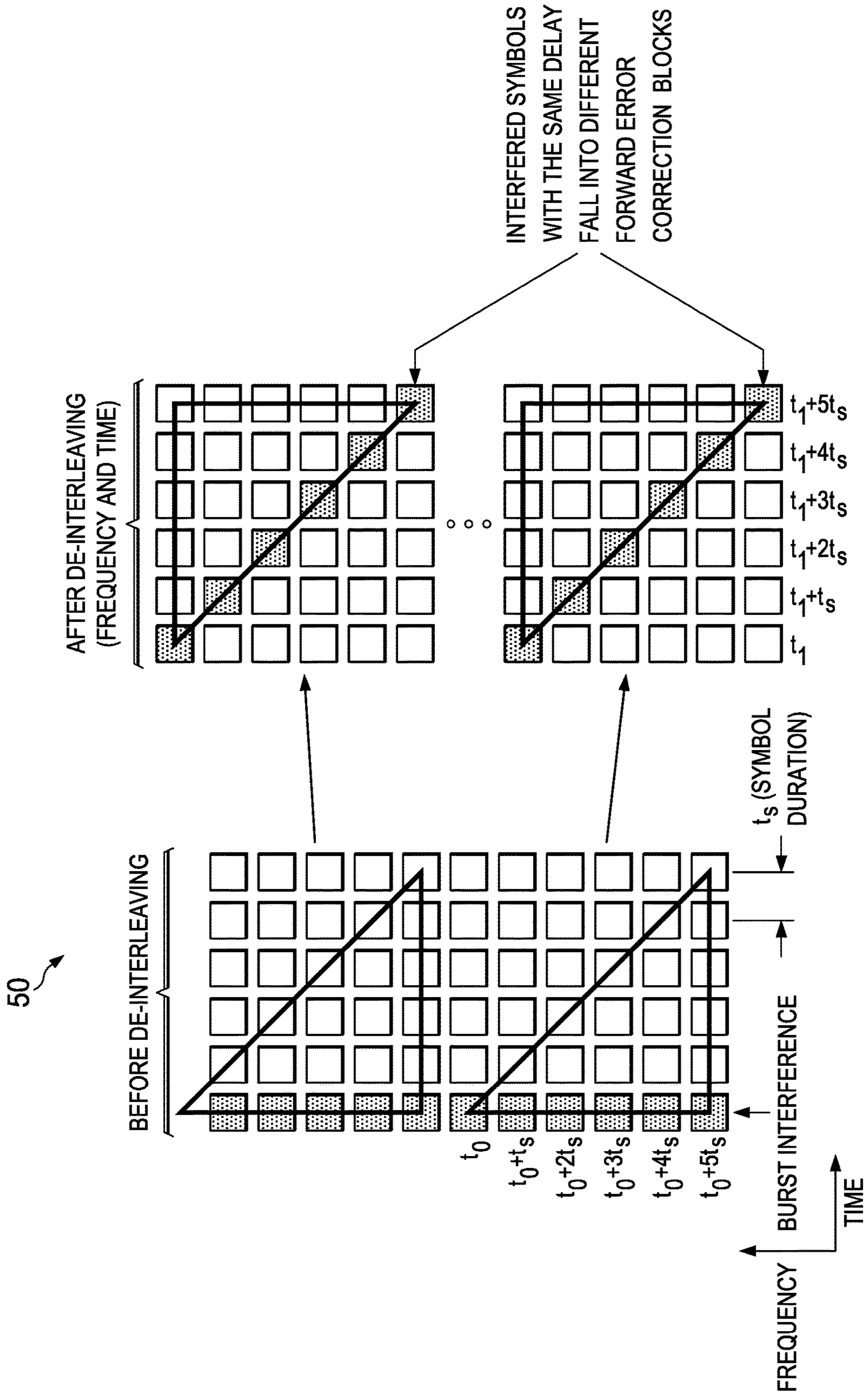

FIG. 8

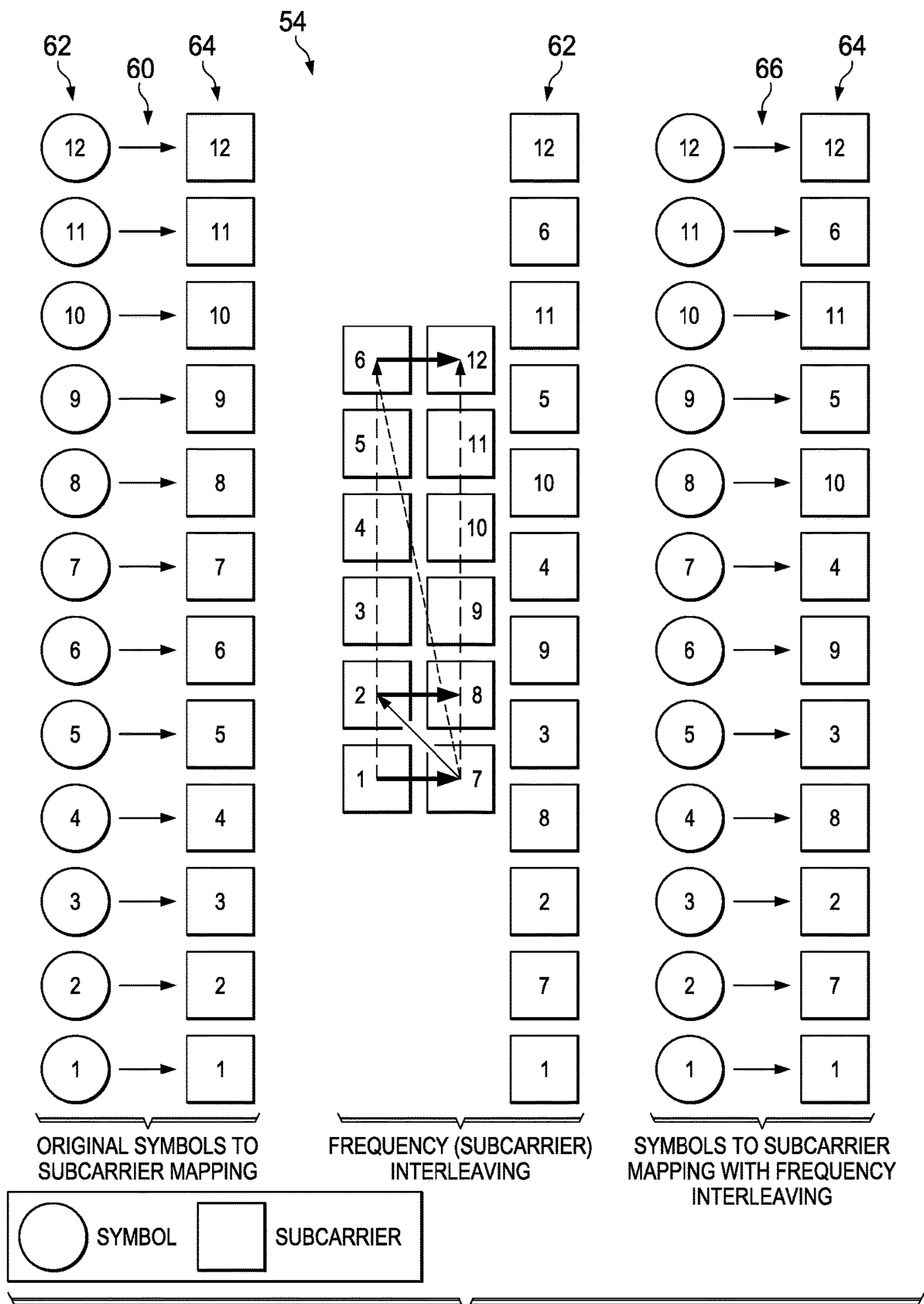

FIG. 9

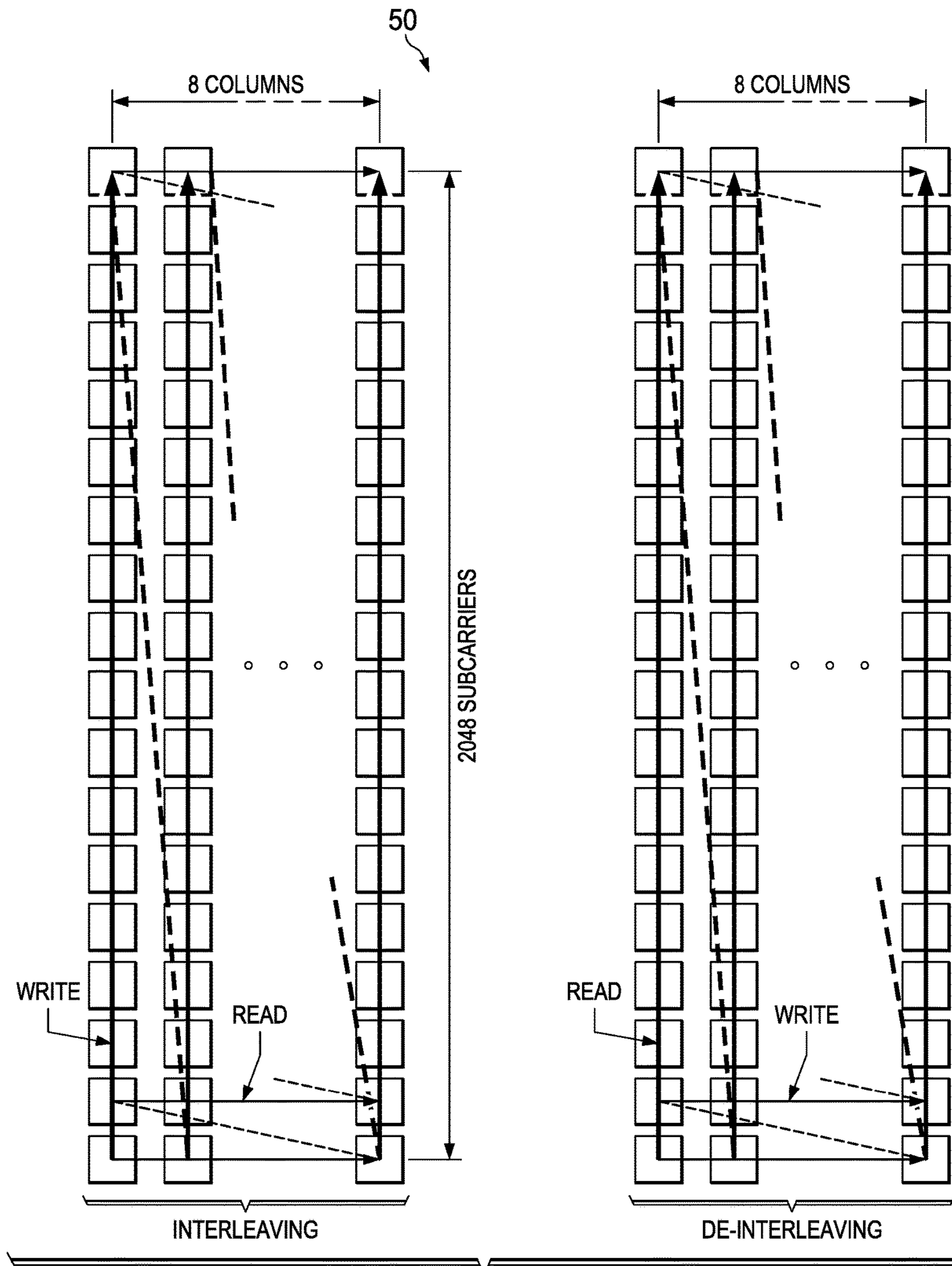

FIG. 10

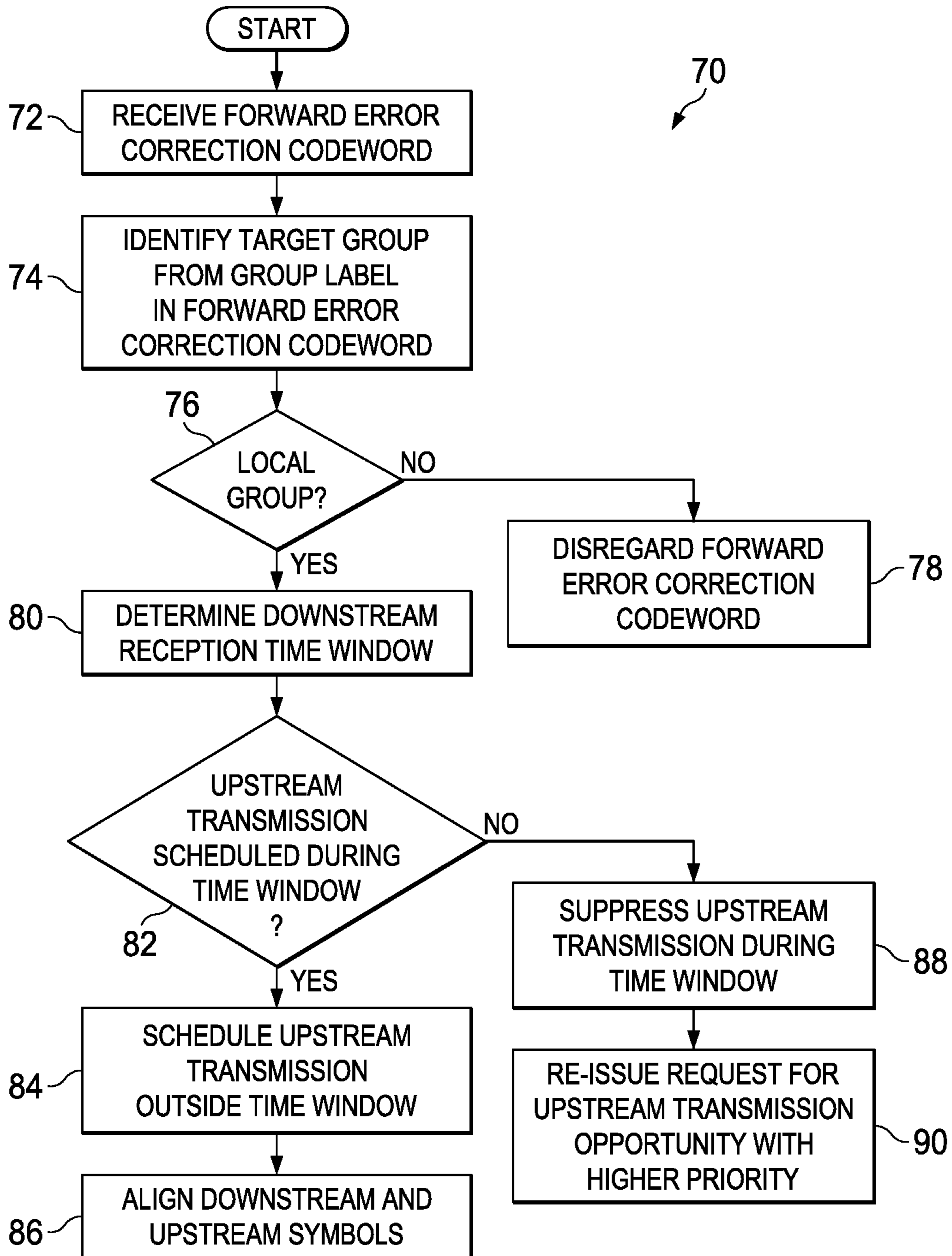

FIG. 11

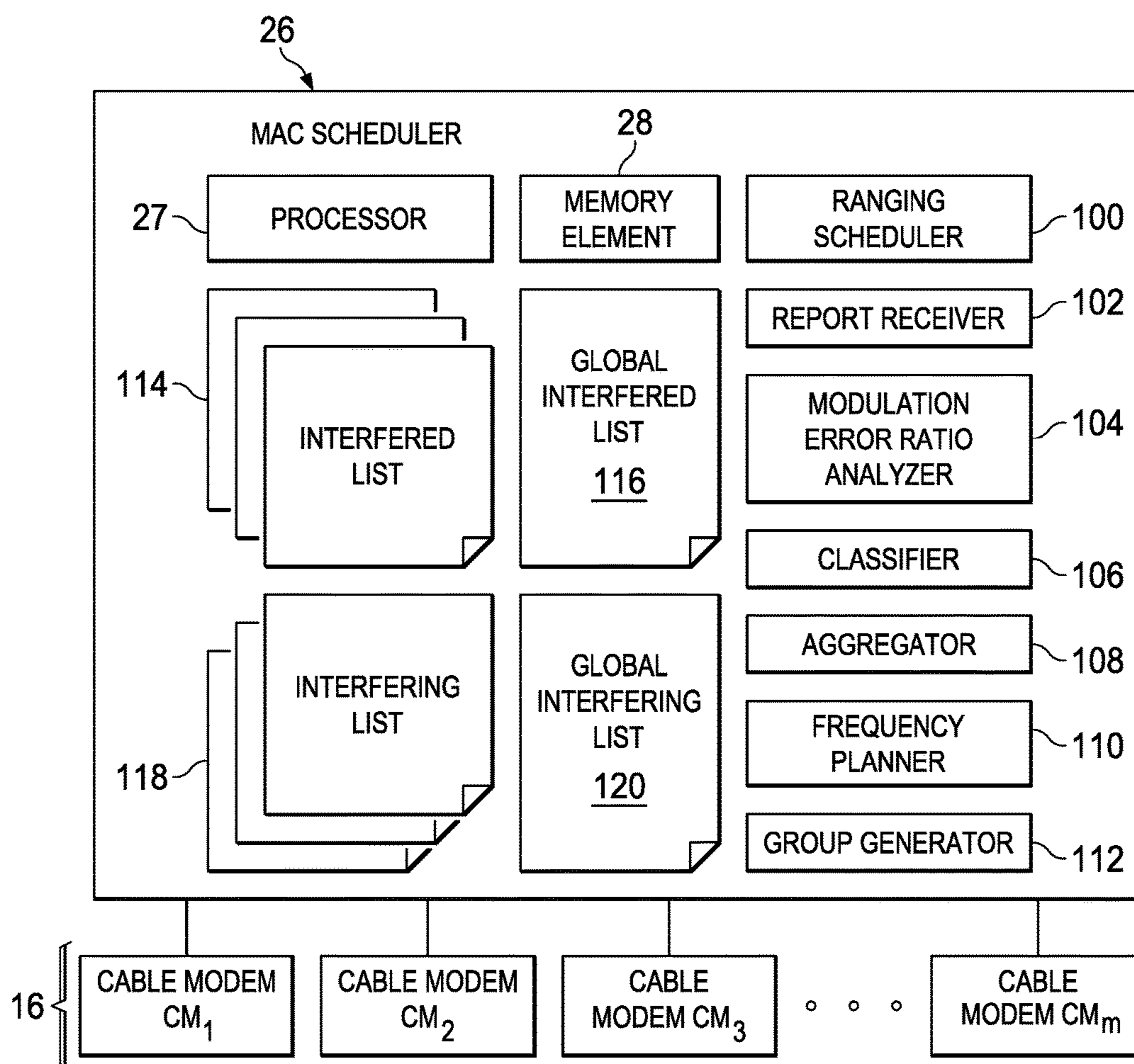
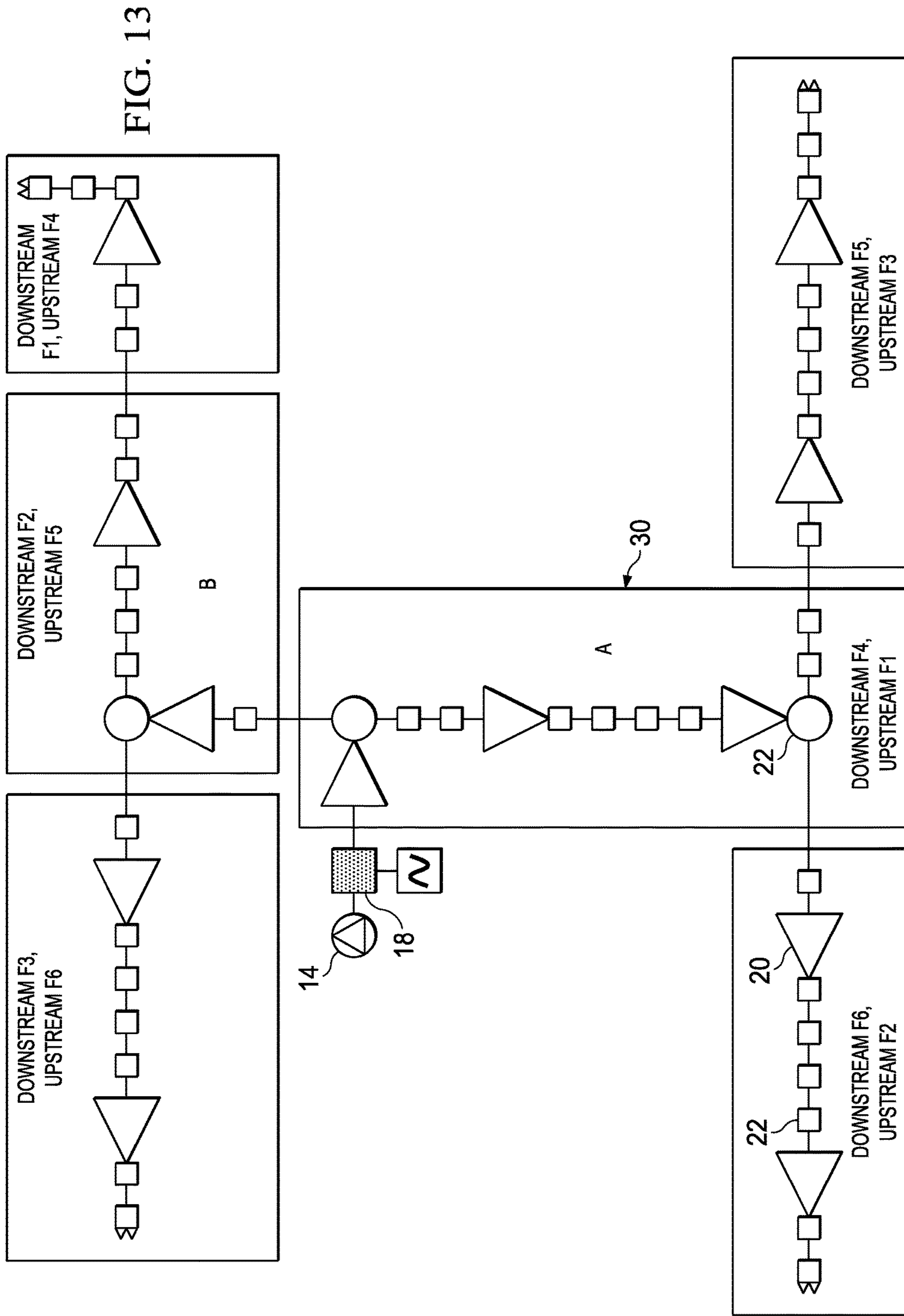

FIG. 12



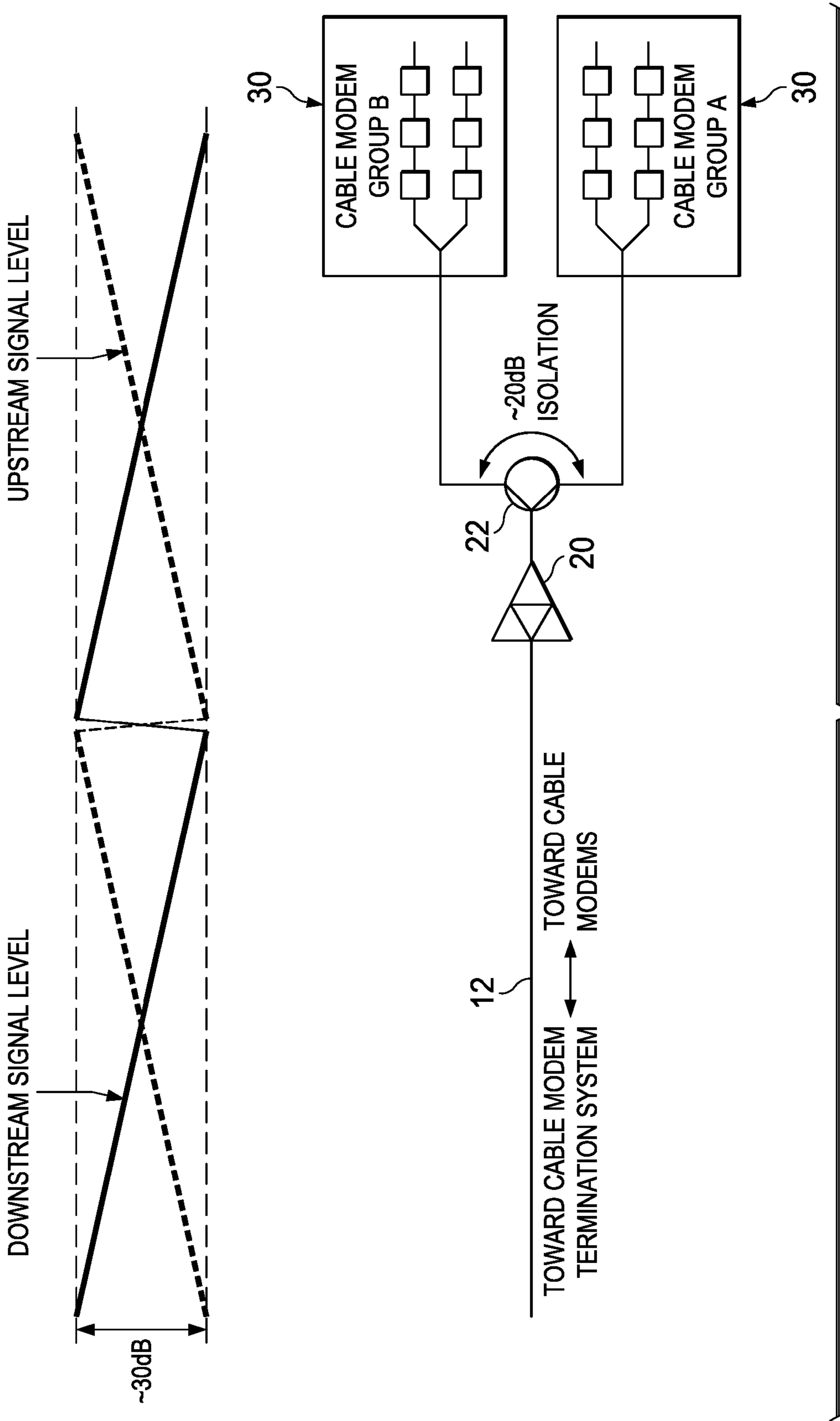

FIG. 14

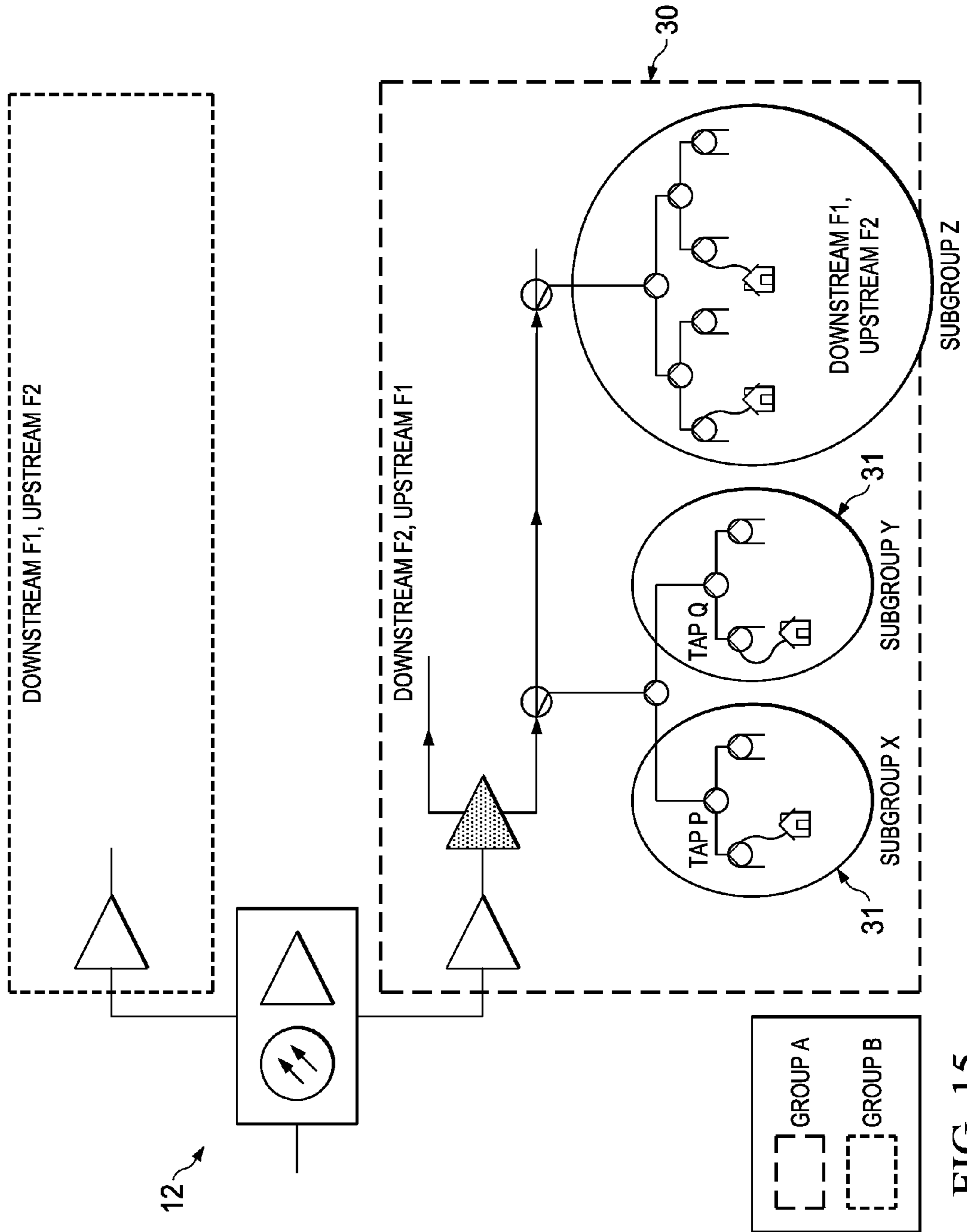

FIG. 15

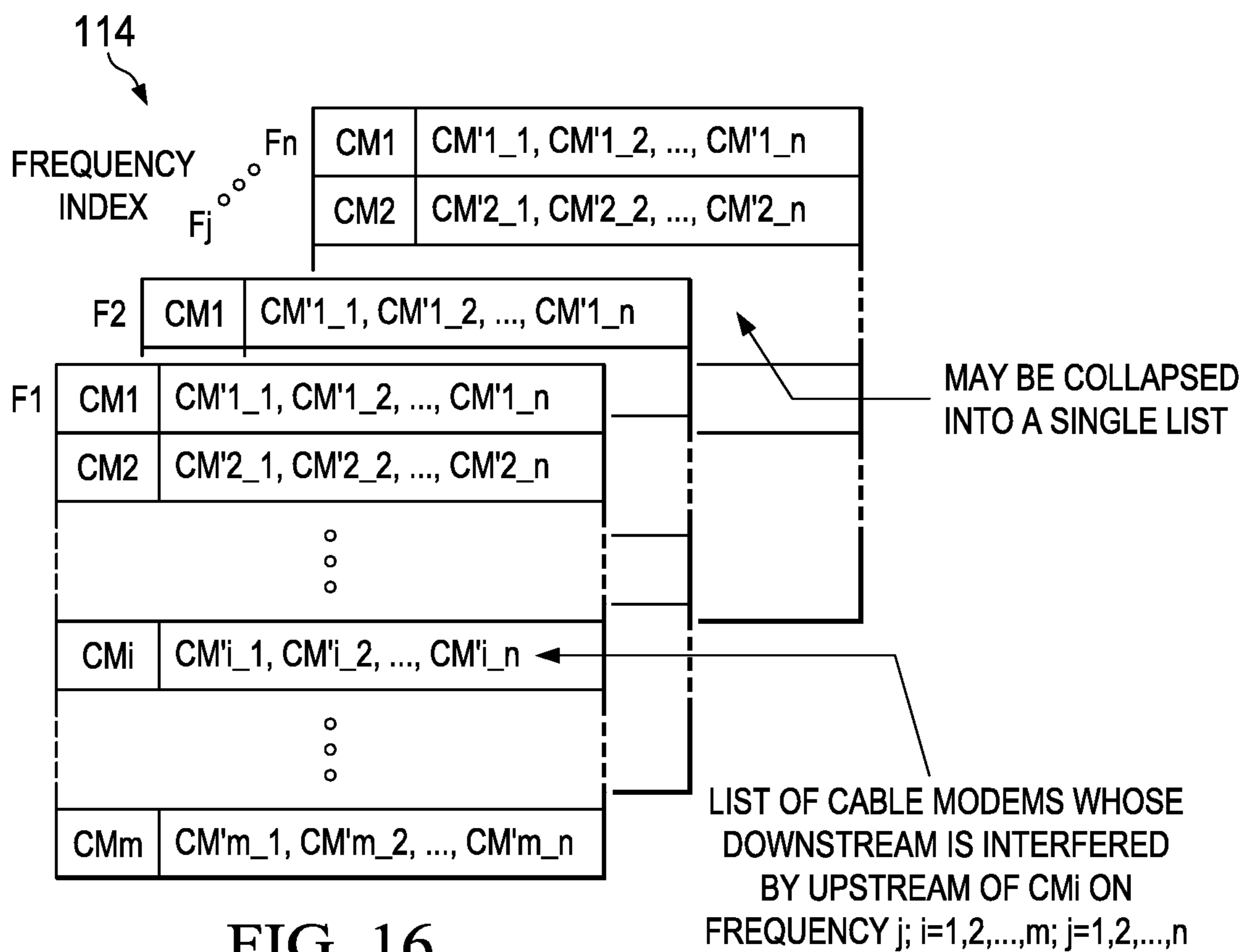
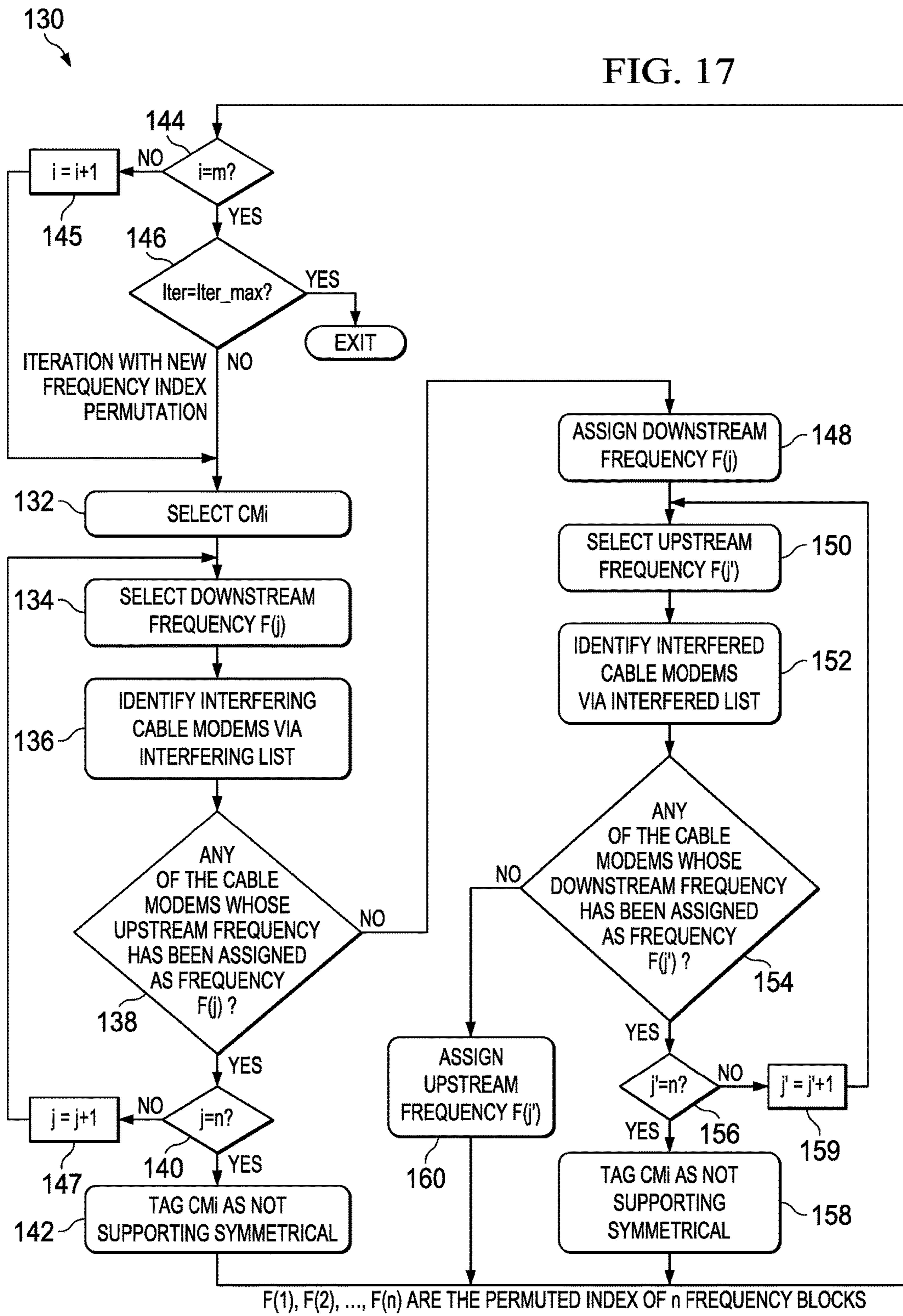

FIG. 16

FIG. 17



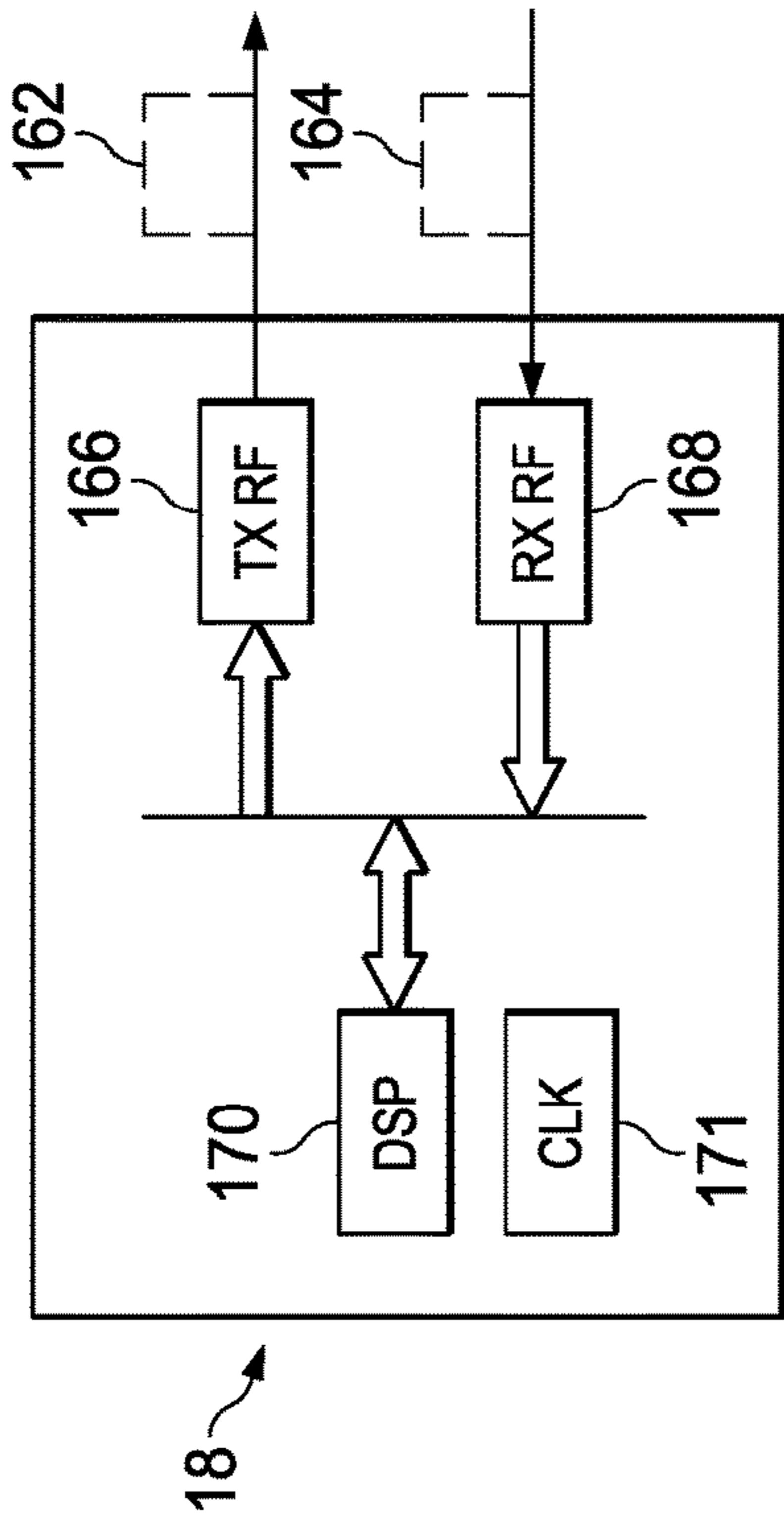

FIG. 18

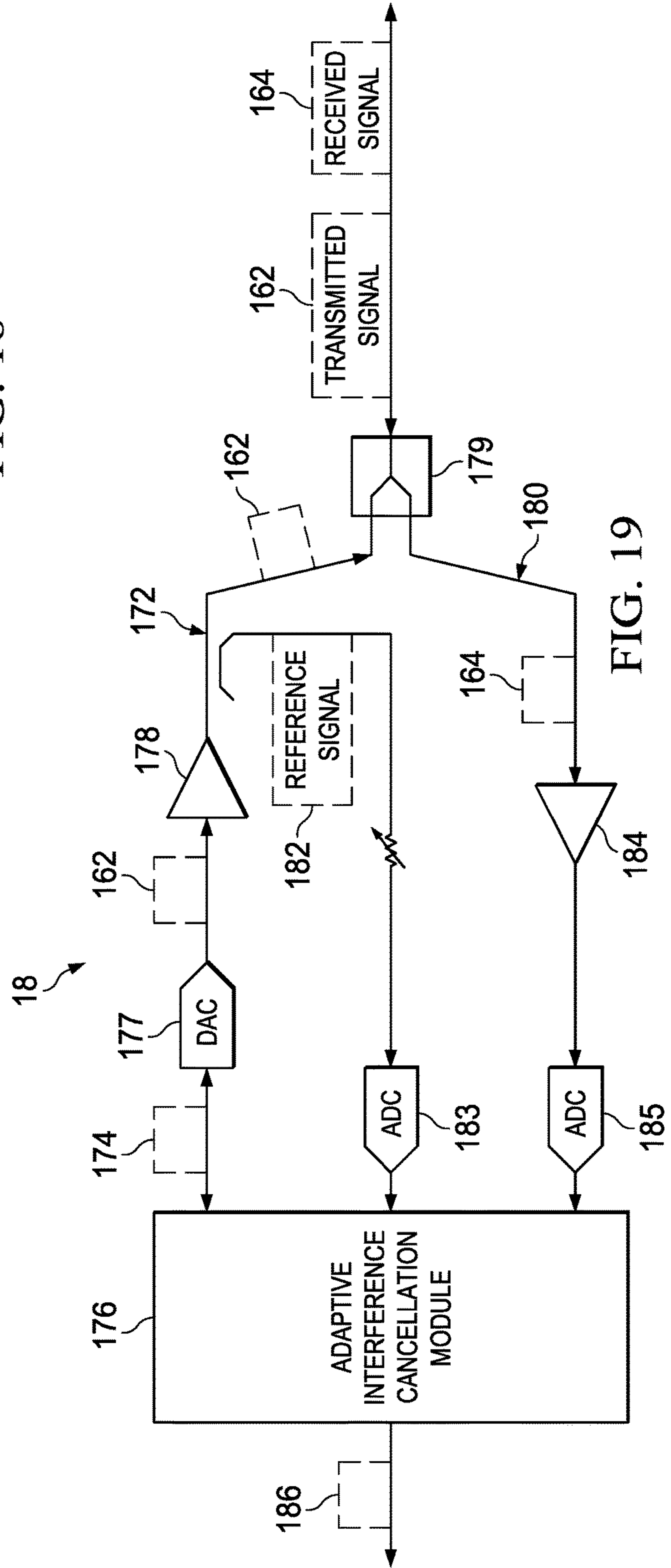
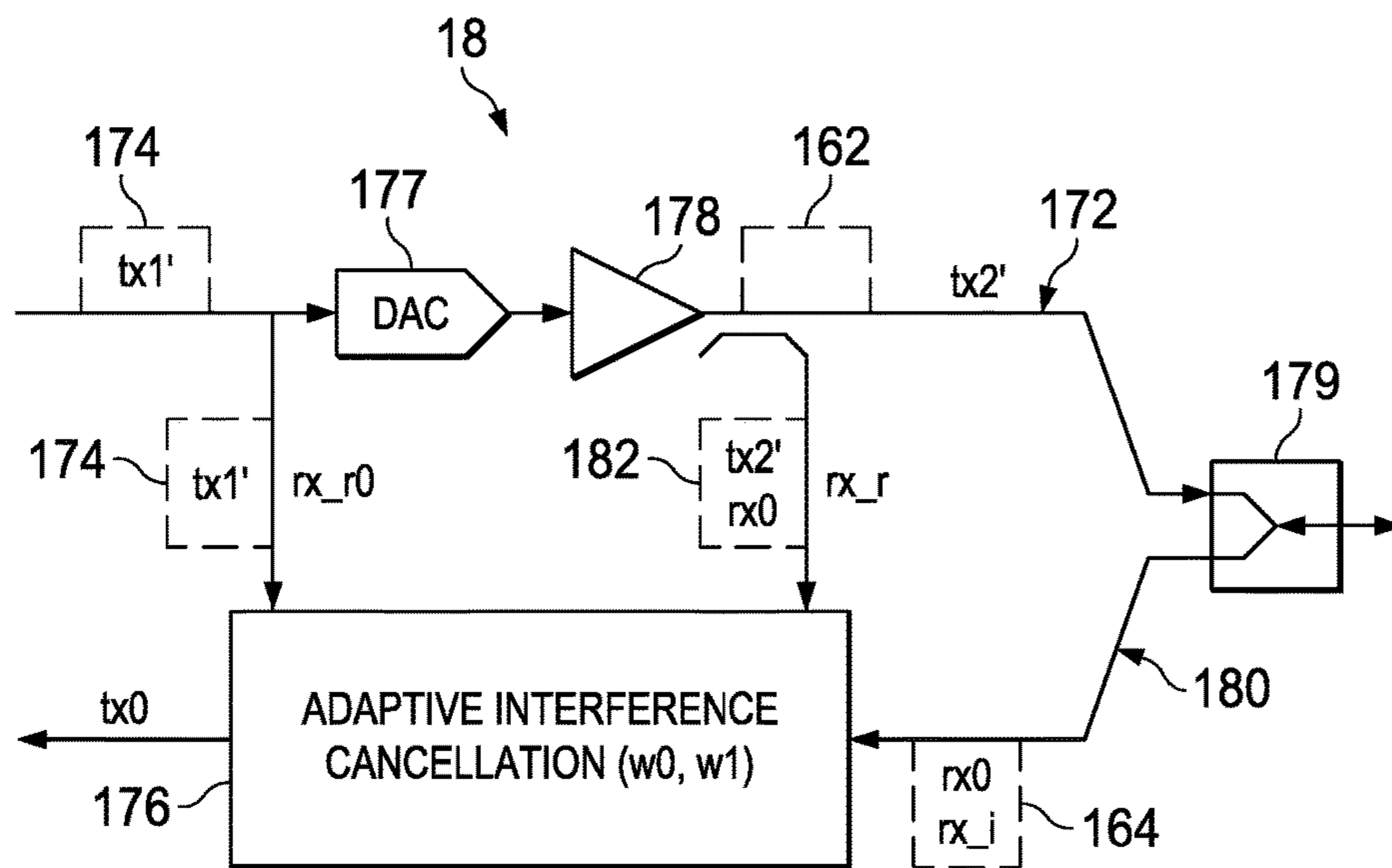

FIG. 19



$rx = rx0 + rx_i;$
 $tx0 = conv(w1, rx) - conv(w0, rx_r)$

FIG. 20

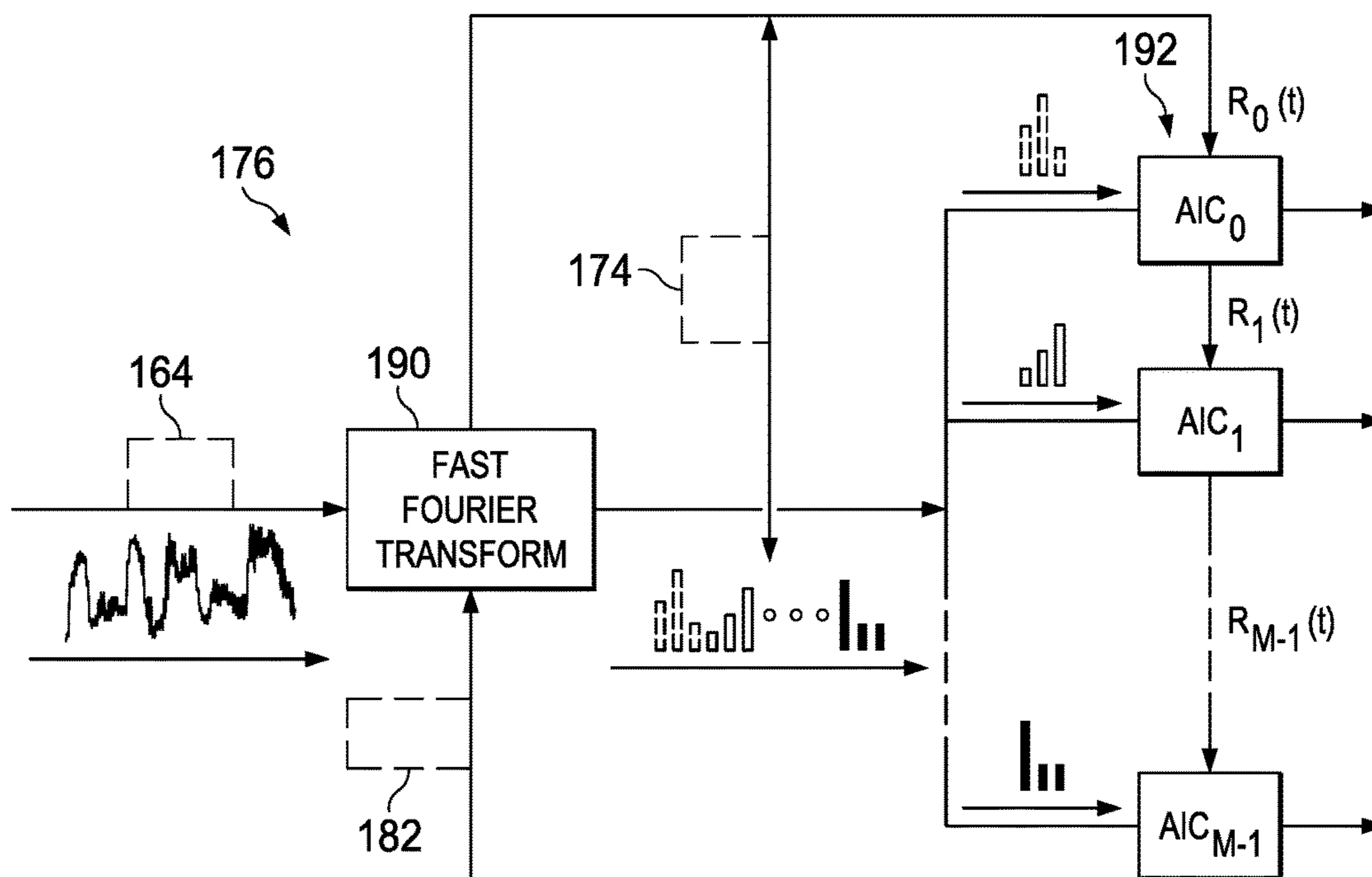

FIG. 21

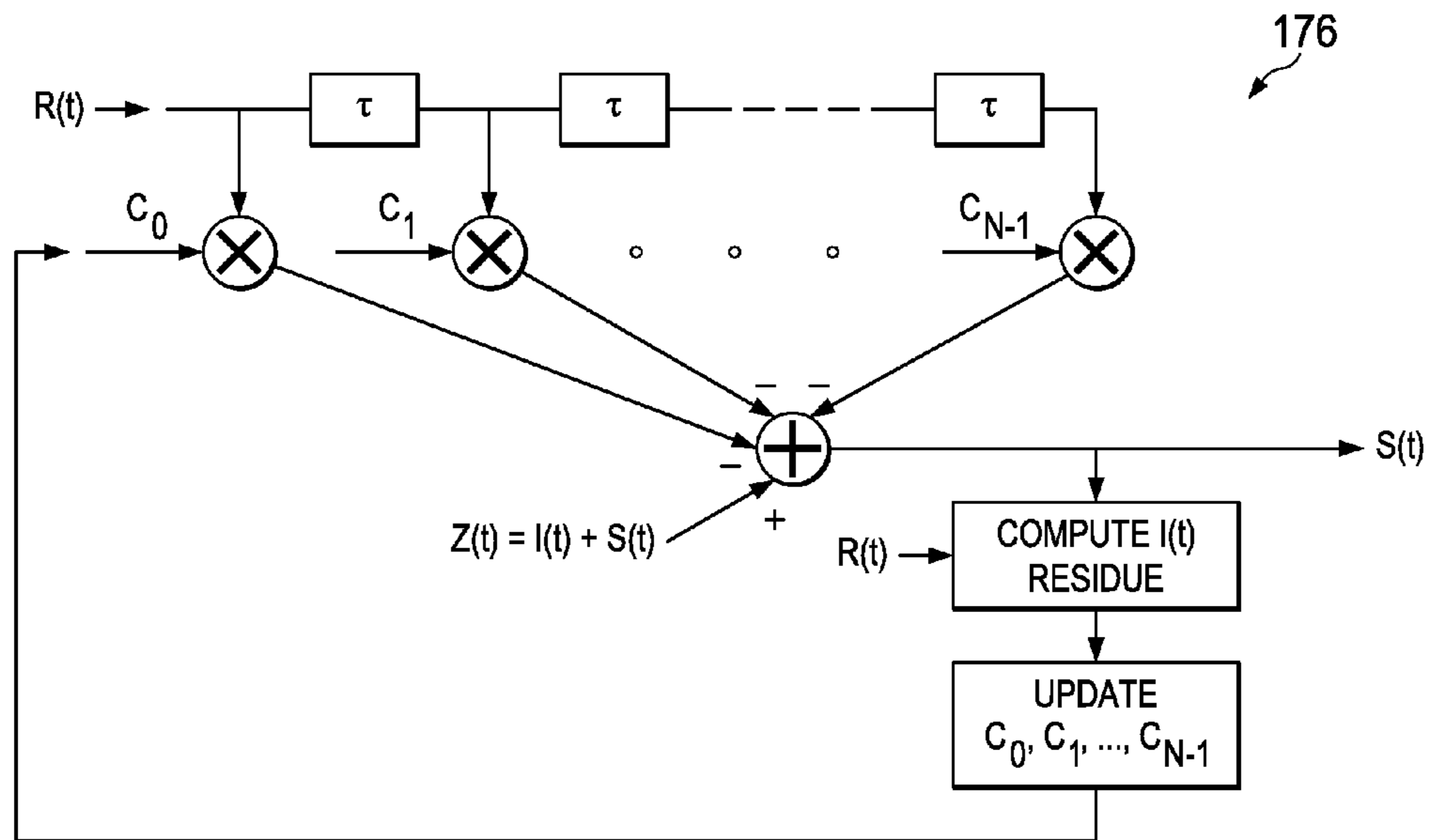

FIG. 22

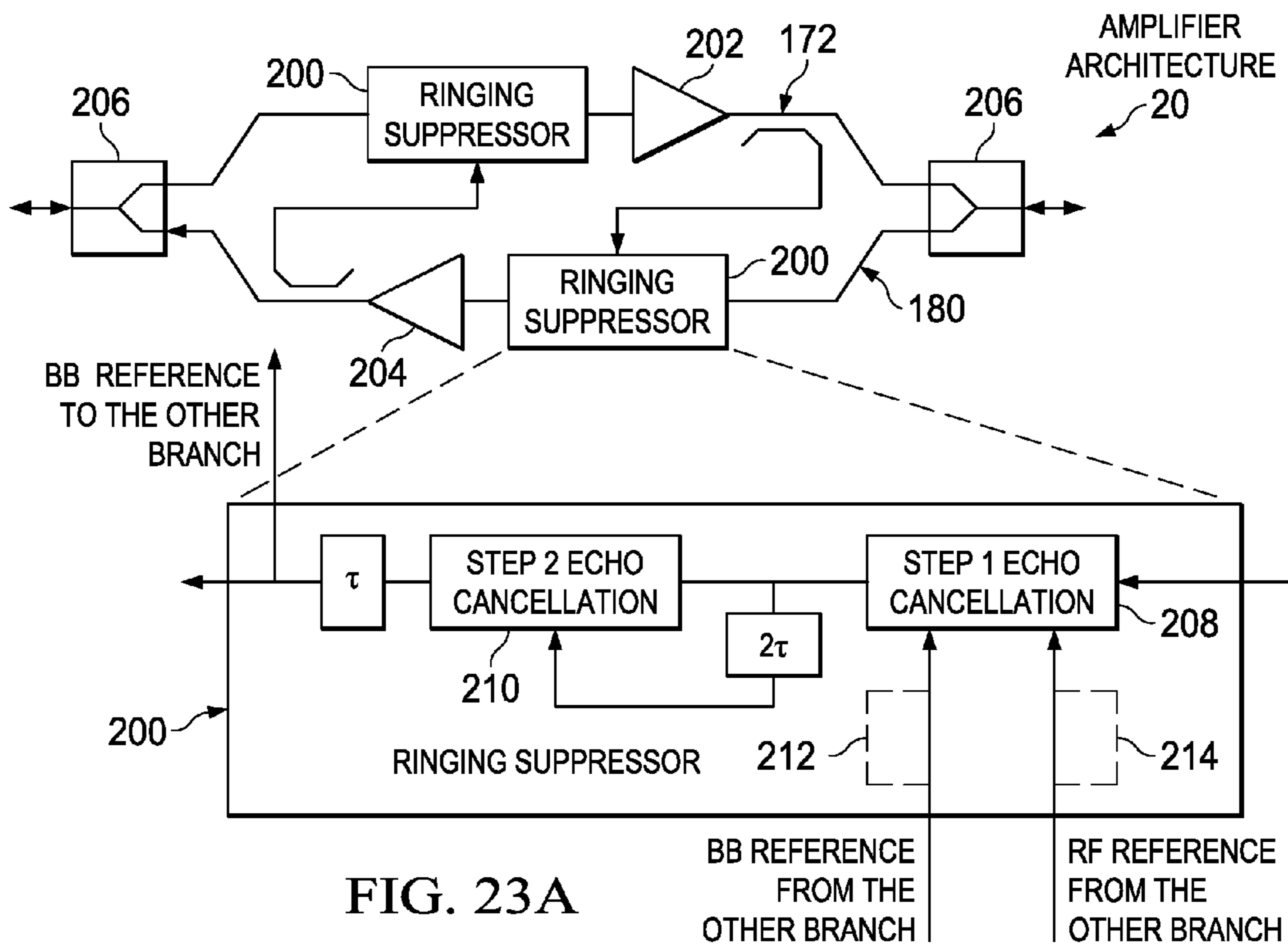

FIG. 23A

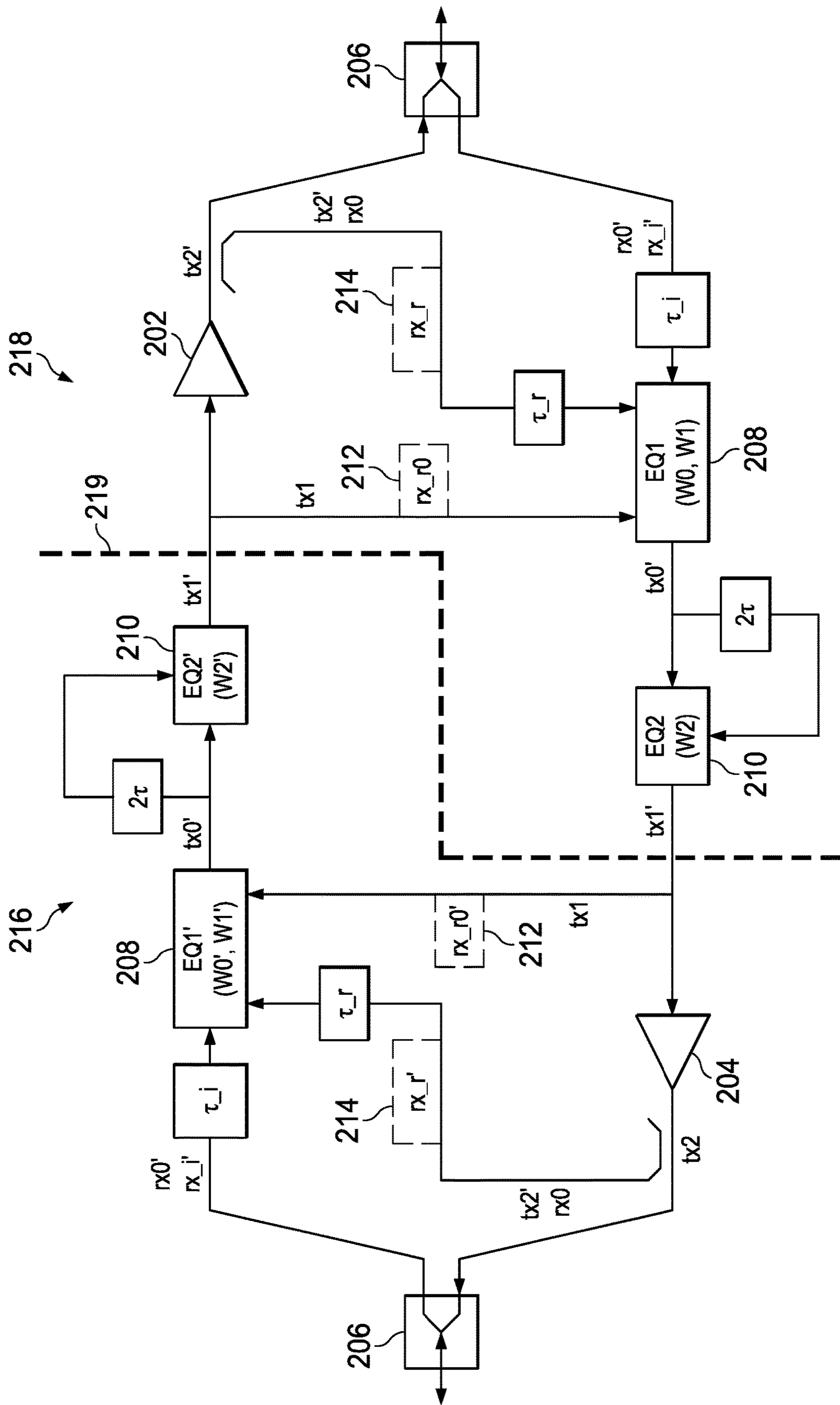

FIG. 23B

220

FIG. 24

```

% Equalizer 1
function [tx0n,U0,dq0,w0,U1,dq1,w1]=...,
    eq1(U0,dq0,w0,U1,dq1,w1,lamda0,alpha0,lamda1,alpha1,rx,rx_r,rx_r0,tau_i,tau_r)

[n0,m0]=size(U0);
m0_sect=n0/m0;
err0=rx(end-tau_i);
wa=[]; Ua=[]; dqa=[];
for i=1:m0_sect
    m_off=(i-1)*m0;
    ref0=rx_r0(end-m_off:-1:end-m_off-m0+1);
    w0t=w0(m_off+1:m_off+m0);
    U0t=U0(m_off+1:m_off+m0,:);
    dq0t=dq0(m_off+1:m_off+m0);

    [w0t,U0t,dq0t,err0]=coefficient_update(U0t,dq0t,w0t,lamda0,alpha0,err0,ref0);
    wa=[wa;w0t];
    Ua=[Ua;U0t];
    dqa=[dqa;dq0t];
end
w0=wa;
U0=Ua;
dq0=dqa;
[n1,m1]=size(U1);
m1_sect=n1/m1;
err1=rx_r(end-tau_r);
wa=[]; Ua=[]; dqa=[];
for i=1:m1_sect
    m_off=(i-1)*m1;
    ref1=rx_r0(end-m_off:-1:end-m_off-m1+1);
    w1t=w1(m_off+1:m_off+m1);
    U1t=U1(m_off+1:m_off+m1,:);
    dq1t=dq1(m_off+1:m_off+m1);

    [w1t,U1t,dq1t,err1]=coefficient_update(U1t,dq1t,w1t,lamda1,alpha1,err1,ref1);
    wa=[wa;w1t];
    Ua=[Ua;U1t];
    dqa=[dqa;dq1t];
end
w1=wa;
U1=Ua;
dq1=dqa;
aa=norm(w1);
w0_tmp = w0/aa;
w1_tmp = w1/aa;
tx0n = w1_tmp*rx(end-tau_i:-1:end-tau_i-m1_sect*m1+1)-...,
    w0_tmp*rx_r(end-tau_r:-1:end-tau_r-m0_sect*m0+1);

```

```

% Equalizer 2
function [tx1n,U2,dq2,w2,lamda2,alpha2]=eq2(U2,dq2,w2,lamda2,alpha2,tau,tx0)

[n,m2]=size(U2);
m_sect=n/m2;

err=tx0(end);

wa=[]; Ua=[]; dqa=[];

for i=1:m_sect;

    m_off=(i-1)*m2;
    ref2=tx0(end-m_off-2*tau:-1:end-m_off-2*tau-m2+1);
    w2t=w2(m_off+1:m_off+m2);
    U2t=U2(m_off+1:m_off+m2,:);
    dq2t=dq2(m_off+1:m_off+m2);

    [w2t,U2t,dq2t,err]=coefficient_update(U2t,dq2t,w2t,lamda2,alpha2,err,ref2);
    wa=[wa;w2t];
    Ua=[Ua;U2t];
    dqa=[dqa;dq2t];

end

w2=wa;
U2=Ua;
dq2=dqa;
tx1n=err;
    
```

FIG. 25

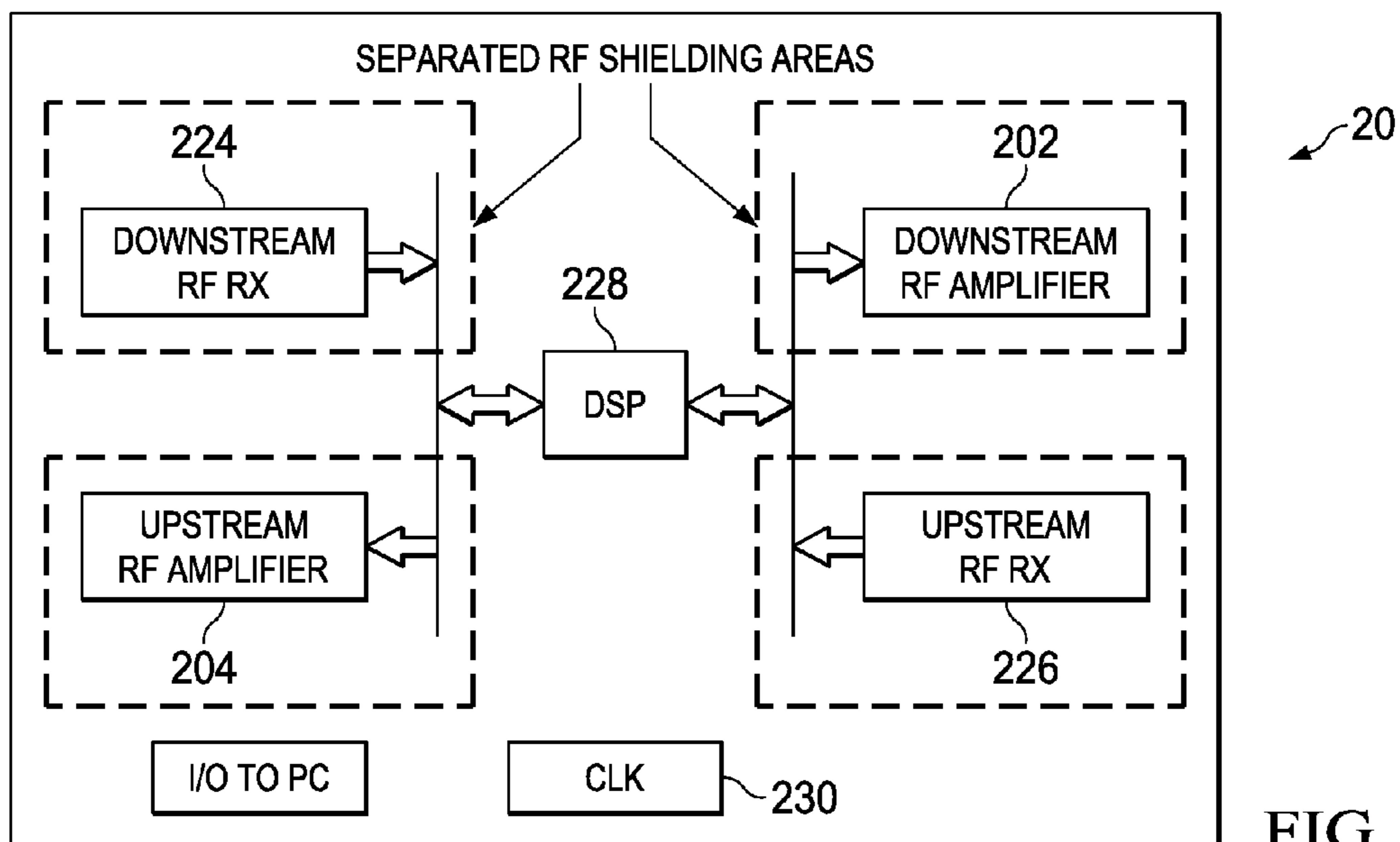
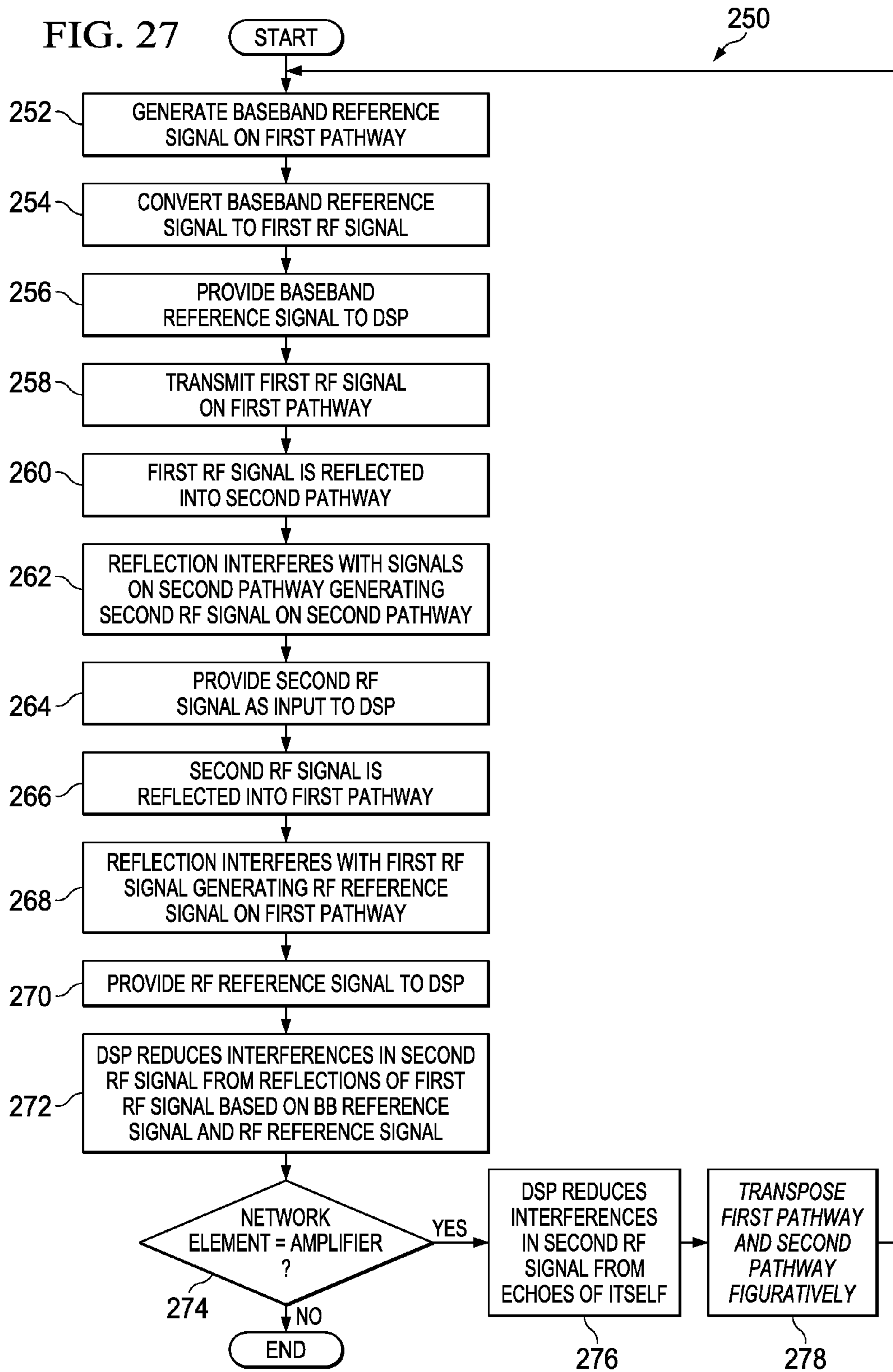

FIG. 26



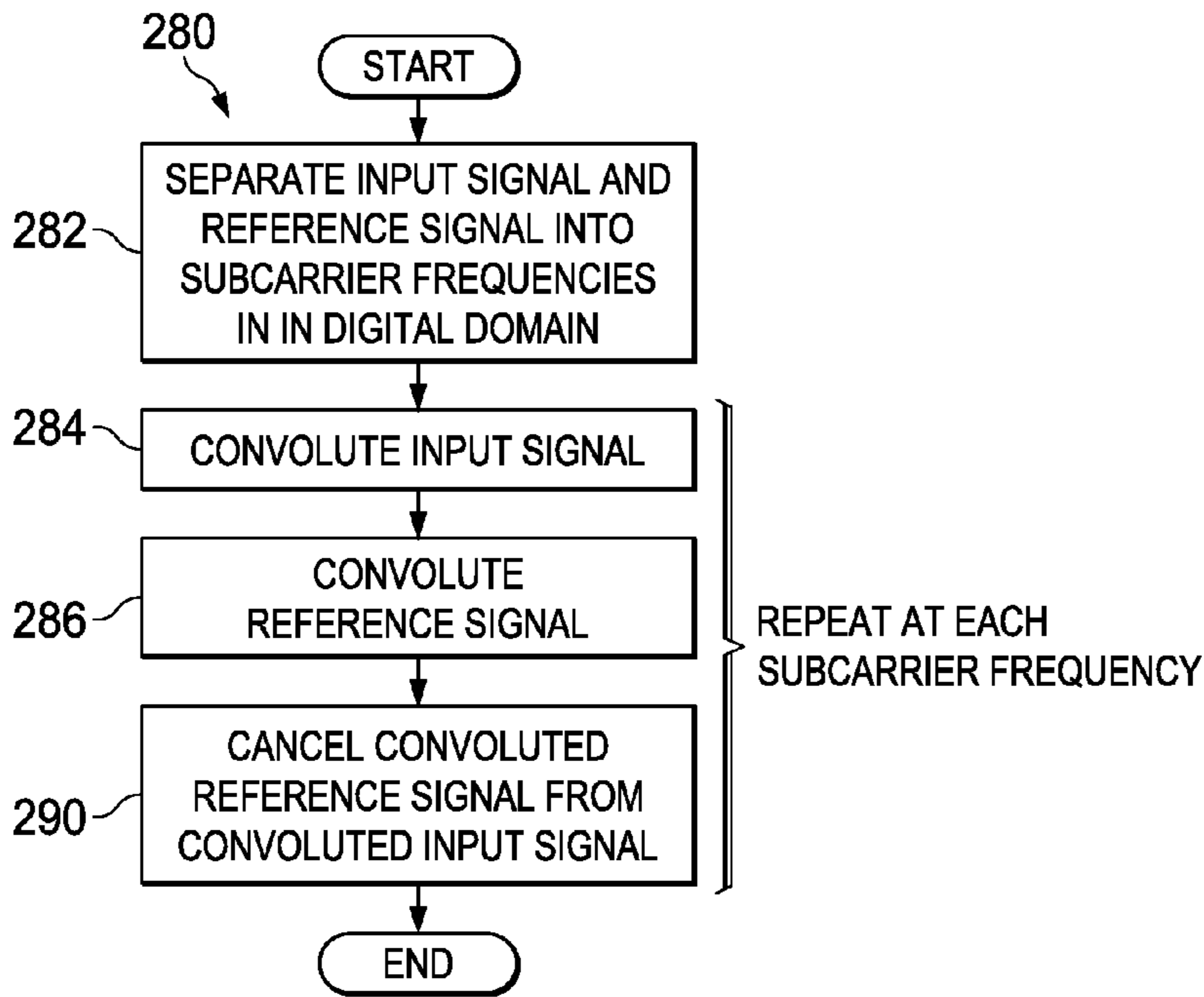

FIG. 28

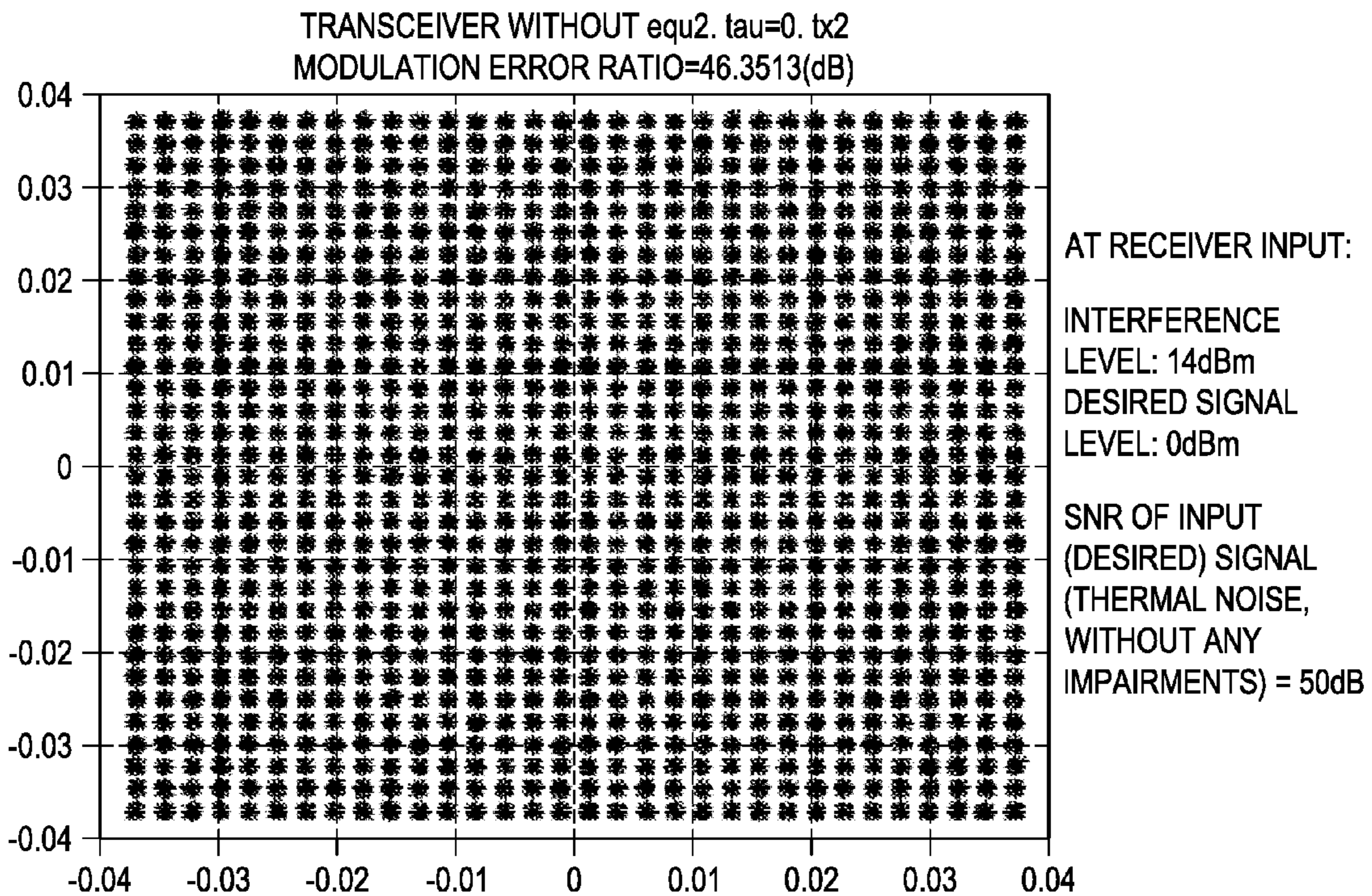

FIG. 30A

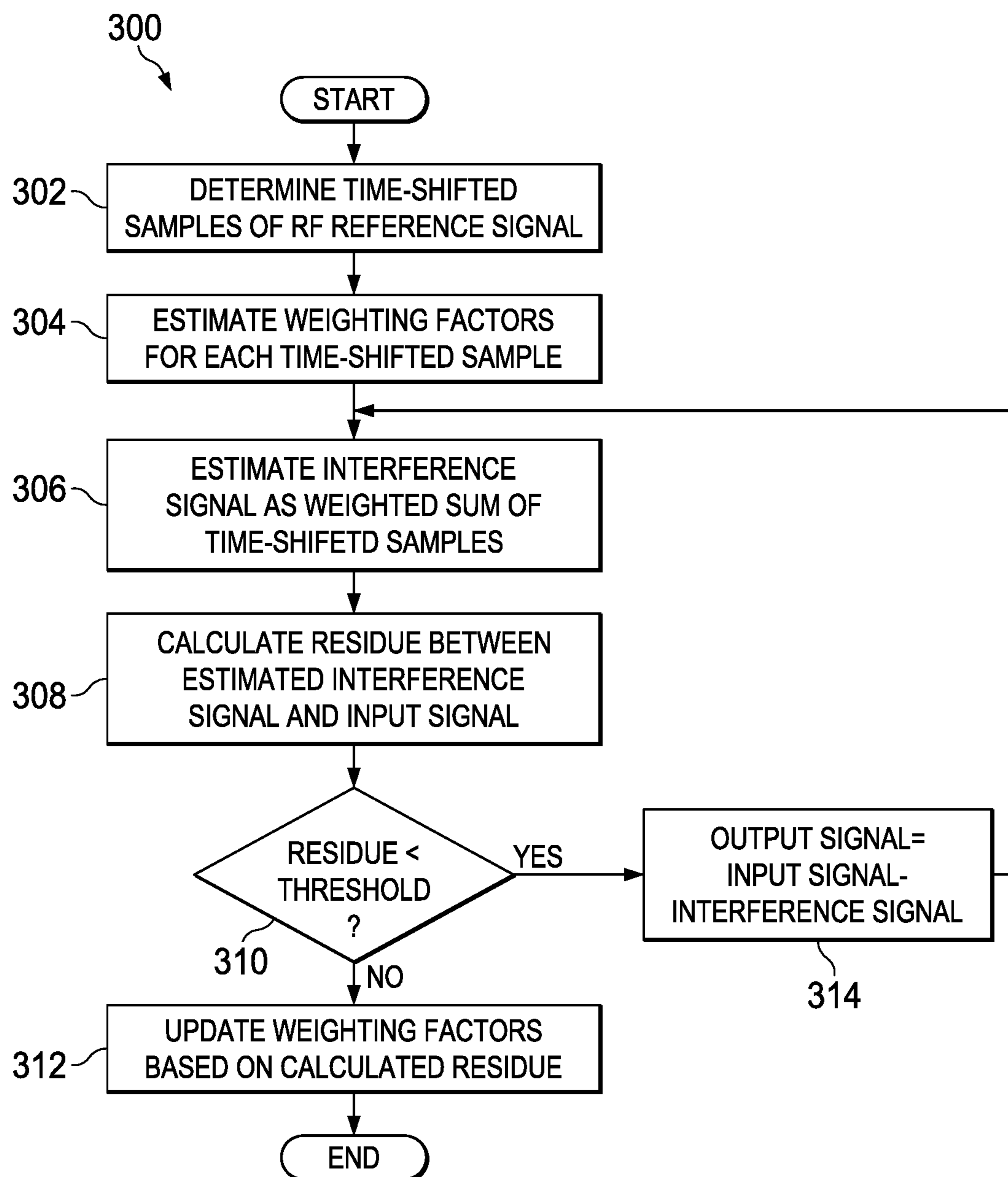

FIG. 29

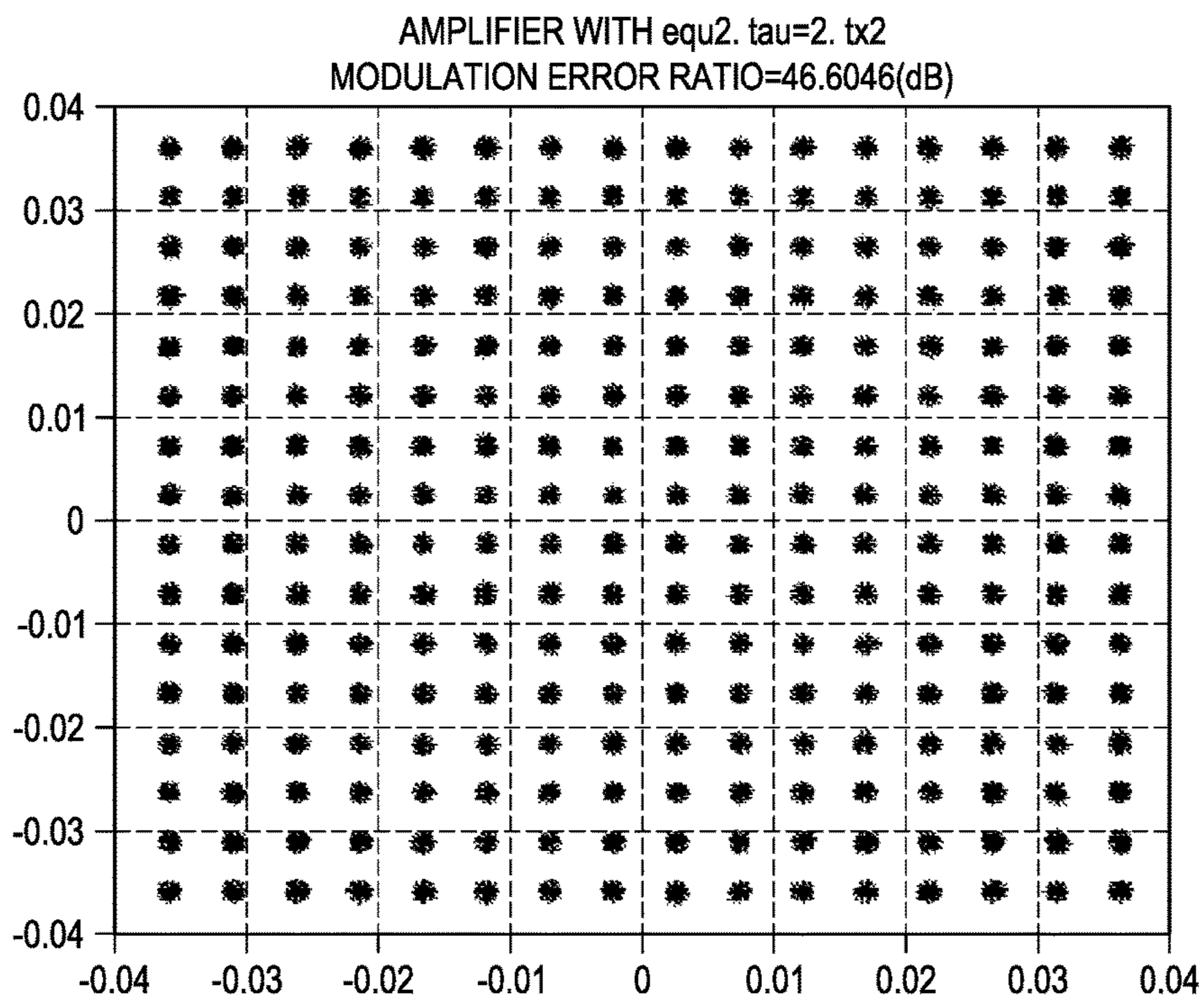

FIG. 30B

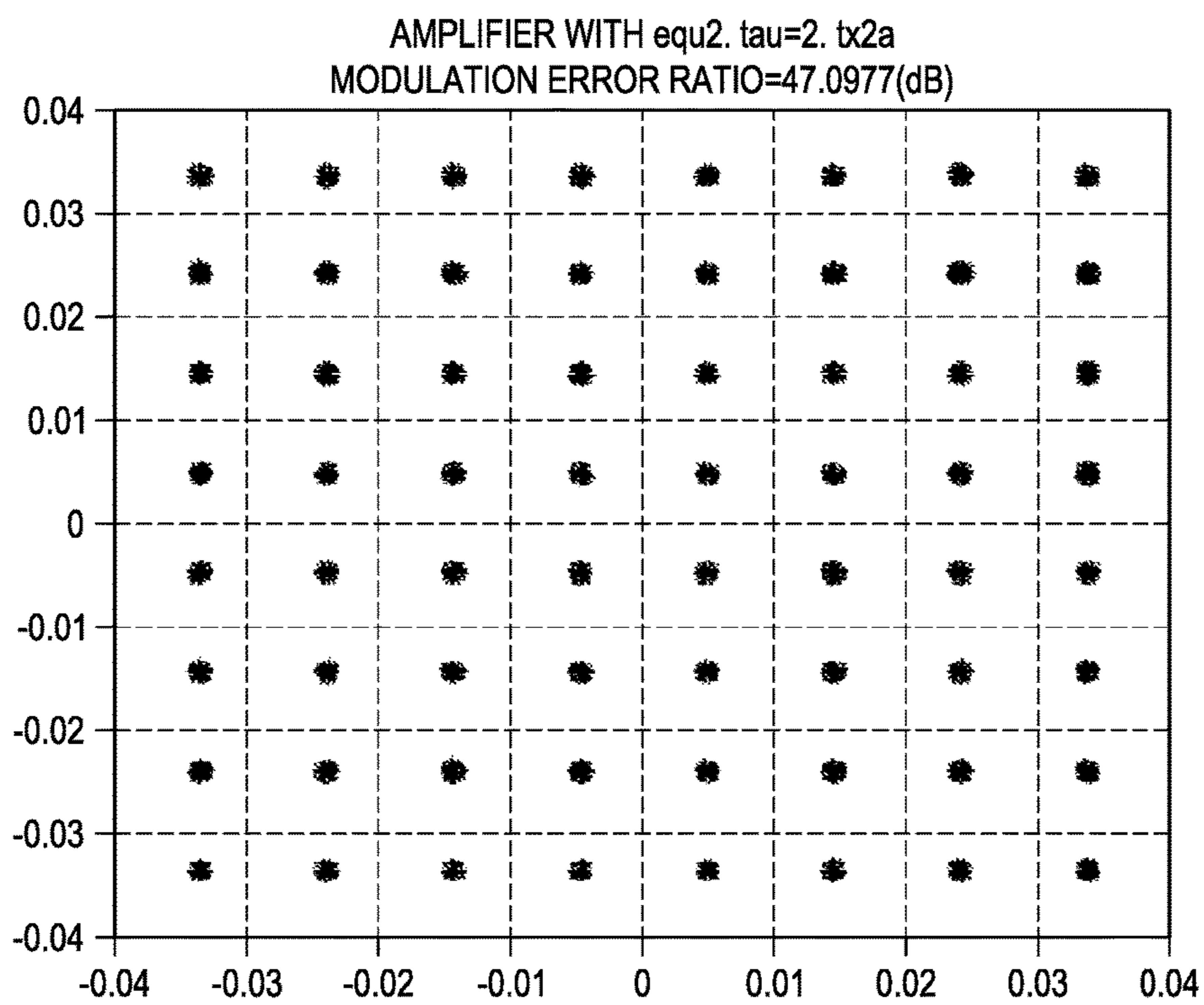

FIG. 30C

1

**INTERFERENCE RELATIONSHIP
CHARACTERIZATION IN FULL DUPLEX
CABLE NETWORK ENVIRONMENTS**

CROSS-REFERENCE TO RELATED
APPLICATION

This application claims the benefit of priority under 35 U.S.C. § 119(e) to U.S. Provisional Application Ser. No. 62/192,924 entitled "FULL DUPLEX OPERATION IN CABLE NETWORKS," filed Jul. 15, 2015, which is hereby incorporated by reference in its entirety.

TECHNICAL FIELD

This disclosure relates in general to the field of communications and, more particularly, to interference relationship characterization in full duplex cable network environments.

BACKGROUND

Consumer appetite for bandwidth continues to grow exponentially in the cable network market. In some cable network architectures, including remote physical layer (RPHY) with digital fiber, the coax fiber becomes the bottleneck in throughput, stifling increase in bandwidth. The typical multi-system operator (MSO) is out of options currently, due to the inherent technological limitations of existing cable network components. For example, the Shannon channel capacity limit (e.g., tight upper bound on rate at which information can be reliably transmitted over a communications channel) has practically been achieved already in existing cable network architectures. There is consumer driven demand to extend the frequency spectrum beyond 1.2 GHz, but a conventional extension would require extensive network upgrade. Upgrades in network components are limited by capital expenditure (CAPEX) budget limitations. All optics (fiber to the home (FTTH) have excessive CAPEX. In such scenarios, it may be desirable to offer new services with full downstream/upstream (DS/US) throughput (e.g., matching Gigabit-capable Passive Optical Networks (GPON) standard of 2.5 Gbits downstream/1 Gbits upstream ratio) with limited capital expenditure for outside plant upgrade.

BRIEF DESCRIPTION OF THE DRAWINGS

To provide a more complete understanding of the present disclosure and features and advantages thereof, reference is made to the following description, taken in conjunction with the accompanying figures, wherein like reference numerals represent like parts, in which:

FIG. 1A is a simplified block diagram illustrating a communication system comprising a full duplex network architecture in cable network environments;

FIG. 1B is a simplified block diagram illustrating example details of embodiments of the communication system;

FIG. 2 is a simplified block diagram illustrating other example details of embodiments of the communication system;

FIG. 3 is a simplified block diagram illustrating yet other example details of embodiments of the communication system;

FIG. 4 is a simplified block diagram illustrating yet other example details of embodiments of the communication system;

2

FIG. 5 is a simplified block diagram illustrating yet other example details of embodiments of the communication system;

FIG. 6 is a simplified block diagram illustrating yet other example details of embodiments of the communication system;

FIG. 7 is a simplified block diagram illustrating yet other example details of embodiments of the communication system;

FIG. 8 is a simplified block diagram illustrating yet other example details of embodiments of the communication system;

FIG. 9 is a simplified block diagram illustrating yet other example details of embodiments of the communication system;

FIG. 10 is a simplified block diagram illustrating yet other example details of embodiments of the communication system;

FIG. 11 is a simplified flow diagram illustrating example operations that may be associated with an embodiment of the communication system;

FIG. 12 is a simplified block diagram illustrating yet other example details of embodiments of the communication system;

FIG. 13 is a simplified block diagram illustrating yet other example details of embodiments of the communication system;

FIG. 14 is a simplified block diagram illustrating yet other example details of embodiments of the communication system;

FIG. 15 is a simplified block diagram illustrating yet other example details of embodiments of the communication system;

FIG. 16 is a simplified diagram illustrating example operations that may be associated with an embodiment of the communication system;

FIG. 17 is a simplified flow diagram illustrating other example operations that may be associated with an embodiment of the communication system;

FIG. 18 is a simplified block diagram illustrating yet other example details of embodiments of the communication system;

FIG. 19 is a simplified block diagram illustrating yet other example details of embodiments of the communication system;

FIG. 20 is a simplified block diagram illustrating yet other example details of embodiments of the communication system;

FIG. 21 is a simplified block diagram illustrating yet other example details of embodiments of the communication system;

FIG. 22 is a simplified block diagram illustrating yet other example details of embodiments of the communication system;

FIG. 23A is a simplified block diagram illustrating yet other example details of embodiments of the communication system;

FIG. 23B is a simplified block diagram illustrating yet other example details of embodiments of the communication system;

FIG. 24 is a simplified diagram illustrating yet other example operations that may be associated with an embodiment of the communication system;

FIG. 25 is a simplified diagram illustrating yet other example operations that may be associated with an embodiment of the communication system;

FIG. 26 is a simplified block diagram illustrating yet other example details of embodiments of the communication system;

FIG. 27 is a simplified flow diagram illustrating yet other example operations that may be associated with an embodiment of the communication system;

FIG. 28 is a simplified flow diagram illustrating yet other example operations that may be associated with an embodiment of the communication system;

FIG. 29 is a simplified flow diagram illustrating yet other example operations that may be associated with an embodiment of the communication system;

FIG. 30A is a simplified diagram illustrating yet other example details of embodiments of the communication system;

FIG. 30B is a simplified diagram illustrating yet other example details of embodiments of the communication system; and

FIG. 30C is a simplified diagram illustrating yet other example details of embodiments of the communication system.

DETAILED DESCRIPTION OF EXAMPLE EMBODIMENTS

Overview

An example method for characterizing interference relationships in full duplex cable network environments is provided and includes generating a global interfered list for a plurality of cable modems in the cable network and for a plurality of frequency ranges, generating a global interfering list for the plurality of cable modems and for the plurality of frequency ranges, assigning respective downstream reception frequency ranges and upstream transmission frequency ranges for the plurality of cable modems based on the global interfered list and the global interfering list, and transmitting to the cable modems corresponding assignment information comprising the respective assigned downstream reception frequency ranges and upstream transmission frequency ranges.

Example Embodiments

Turning to FIG. 1A, FIG. 1A is a simplified block diagram illustrating a communication system 10 enabling full duplex network communication in cable network environments in accordance with one example embodiment. FIG. 1 illustrates a cable network 12 (indicated generally by an arrow) facilitating full duplex communication between a cable modem termination system (CMTS) 14 and one or more cable modems (CMs) 16. Network 12 includes transceivers 18, amplifiers 20, and taps and splitters 22. CMTS 14 includes an intelligent media access control (MAC) scheduler 26 that enables a two-dimensional transmission-reception (T-R) coordination for interference avoidance, along with a processor 27 and a memory element 28 that facilitate executing instructions comprised in MAC scheduler 26. In various embodiments, cable modems 16 may be grouped into various interference groups 30 to enable full duplex communication with little to no interference. Groups 30 may comprise radio frequency (RF) isolated groups that allow frequency re-use through intelligent MAC scheduling.

Transceivers 18 enable full band communication for both upstream and downstream network traffic and implement dynamic interference cancellation, also referred to herein as adaptive interference cancellation (AIC). Note that as used herein, the term “upstream” refers to a communication

direction from cable modems 16 towards CMTS 14; the term “downstream” refers to a communication direction from CMTS 14 towards cable modems 16. Amplifiers 20 enable full band communication for both upstream and downstream network traffic, and implement AIC with ringing (e.g., echo) suppression. Taps and splitters 22 may enable full band communication for downstream and upstream traffic.

Each of cable modems 16 supports full band communication, but operates in simplex mode for upstream or downstream transmission. For example, each of cable modems 16 may be assigned non-overlapping frequency bands for upstream and downstream communication, yet the same set of carriers can be used for the downstream and upstream communication, yielding a doubling of throughput compared to currently existing non-full duplex systems. Communication system 10 can enable higher bandwidth (e.g., bandwidth is the maximum amount of data that can travel through a communication channel) and throughput (e.g., throughput refers to the quantity of data that actually does travel through the communication channel successfully) through full-duplex communication.

To explain generally, bandwidth limitations are solved in some communication networks through duplex communication. In a general sense, duplex communication is bidirectional, allowing both end nodes of a communication channel to send and receive data simultaneously and one at a time. Both end nodes have the ability to operate as sender and receiver at the same time, or take turns sending or receiving data. Duplex-based systems typically have dual communication channels that provide separate medium (e.g., paths) for upstream (US) (e.g., uplink, outgoing, transmitting) and downstream (DS) (e.g., downlink, incoming, receiving) communication. In full duplex mode, the node sends and receives signals simultaneously on the same frequency range.

Examples of communication techniques include frequency division duplexing (FDD) and time division duplexing (TDD). In FDD, separate frequency bands (e.g., carrier frequencies) are used at the transmitter and receiver. Because FDD uses different frequency bands for upstream and downstream operations, the upstream and downstream communication do not interfere with each other. Examples of FDD systems include the following: asymmetric digital subscriber line (ADSL) and very-high-bitrate digital subscriber line (VDSL); cellular systems, including UMTS/WCDMA Frequency Division Duplexing mode and the CDMA2000 system; IEEE 802.16 WiMax Frequency Division Duplexing mode.

In TDD, the upstream communication is separated from the downstream communication by allocation of different time slots in the same frequency range. For example, users, such as cable modems, are allocated time slots for upstream transmission and downstream reception. TDD allows asymmetric flow for upstream and downstream data transmission. TDD is advantageous in cases where upstream and downstream data rates are asymmetric. The capacities of downstream communication links and upstream communication links are altered in favor of one direction over another by providing greater time allocation through time slots to downstream reception intervals than to upstream transmission intervals.

Full duplex communication mechanisms that are not FDD or TDD have not been used in cable networks, because the inherent network architecture and communication protocols do not support such communication mechanisms. For example, cable was first introduced in the United States in

the late 1950s. For the next 30 years, nearly every mile of buried cable was half duplex; thus, the network was capable of broadband transmission in the downstream direction, from the head end to the subscriber, but not in the upstream direction—communication from the subscriber back to the head end was possible only via a telephone line. In recent years, cable operators have been investing heavily to upgrade their buried cables from half to full duplex as a necessary first step to capitalize on the demand for integrated data and voice services. However, upstream transmissions continue to be slower than downstream receptions (typically 1.5 to 3 Mbps downstream and 500 Kbps to 2.5 Mbps upstream).

Nevertheless, with a properly configured cable network architecture, such as cable network **12** of communication system **10**, full duplex communication can drastically expand available upstream spectrum (e.g., estimated 5 to 10 times upstream capacity increase). Full duplex communication can provide near symmetric downstream and upstream throughput. System capacities (e.g., bandwidth) can improve with full duplex communication. Moreover, full duplex communication may be technology-agnostic and/or standards-agnostic.

However, implementing full duplex in existing cable networks meet with certain challenges. For example, a large transmitted signal coupled back to the receiver due to reflection (e.g., self-interference from the transmit pathway into the receive pathway within one and same transceiver) at any of the network components, including CMTS **14**, cable modems **16**, transceivers **18**, amplifiers **20** and taps and splitters **22** can kill the received signal at the receiver. Moreover, upstream transmit signal from one of cable modems **16** may leak into the downstream pathway of another of cable modems **16**, causing interference. Unlike self-interference, such inter-CM interference cannot be removed with mere echo cancellation techniques because the upstream transmit signal is unknown in the downstream pathway.

Embodiments of communication system **10** can resolve such issues by enabling full duplex communication using appropriately configured components and spectrum sharing techniques. Full duplex communication can be successfully implemented by suppressing (e.g., eliminating) transmitted signals that are coupled back to the receiver (e.g., as an echo, as an upstream signal leaking into the downstream pathway and vice versa, etc.). Sufficient transmitted signal cancellation and/or elimination can be achieved by leveraging (among other parameters) state of art devices and digital signal processing technologies, high speed and high performance (e.g., high resolution) analog to digital converters (ADC), powerful devices with more signal processing capability, an AIC scheme, and advanced MAC scheduling for spectrum sharing. In various embodiments, the AIC scheme suppresses at a receiver (of transceiver **18** or amplifier **20** appropriately) a signal transmitted by a transmitter (of transceiver **18** or amplifier **20** appropriately). Further, in addition to the AIC scheme, full band amplifier **20** implements a ringing suppression scheme implementing echo cancellation.

According to embodiments of communication system **10**, MAC scheduler **26** implements a two-dimensional transmission-reception (T-R) coordination scheme among cable modems **16** in cable network **12**. According to the T-R coordination scheme, cable modems **16** are categorized into interference groups **30**, such that no cable modem of any one interference group transmits upstream in a frequency range simultaneously as another cable modem in the same inter-

ference group receives downstream in the frequency range, facilitating full duplex communication in cable network **12** across the frequency range. Cable modems **16** operate in simplex mode, while supporting full band operation for downstream reception and upstream transmission. Note that cable modems **16** in different interference groups **30** transmit upstream and receive downstream simultaneously in the frequency range. In various embodiments, CMTS **14** receives and transmits network traffic across the entire frequency range, facilitating full duplex communication in cable network **12**. In some embodiments, cable modems **16** are classified into interference groups **30** through a ranging process.

In some embodiments, MAC scheduler **26** implements the T-R coordination centrally in cable network **12**. To explain in further detail, the available frequency spectrum of communication system **10** is divided into frequency resource blocks, comprising a band of adjacent frequencies (e.g., contiguous sub-carriers). OFDM symbols in time space are grouped into the resource blocks in frequency space. According to the centrally implemented T-R coordination scheme, MAC scheduler **26** partitions resource blocks available to any one interference group into at least a first portion and a second portion; the first portion is reserved for upstream transmission, and the second portion is reserved for downstream reception, such that the first portion and the second portion do not overlap in time and frequency for any cable modem in the interference group. In other embodiments, MAC scheduler **26** implements the T-R coordination in a distributed manner in cable network **12**. According to the distributed T-R coordination scheme, cable modems **16** manage scheduling upstream transmission and downstream reception in any one interference group. MAC scheduler **26** transmits a downstream transmission map ahead of downstream transmission to cable modems **16**, and cable modems **16** schedule respective upstream transmission according to the downstream map.

In various embodiments, a cable network operator may upgrade an existing cable network operating in simplex mode to a full duplex mode by adding appropriate components supporting full duplex communication. For example, the cable network operator may implement a method for full duplex communication in cable network **12** by operating MAC scheduler **26** implementing the above-described two-dimensional T-R coordination scheme among cable modems **16**, operating full band transceiver **18** implementing the AIC scheme, and operating full band amplifier **20** implementing the AIC scheme and the ringing suppression scheme implementing echo cancellation. The cable network operator may add to cable network **12** one or more taps and splitters **22** that support full band communication in cable network **12**.

Moreover, capital expenditure for upgrading to full duplex communication may be reduced by reusing certain components. Turning to FIG. 1B, FIG. 1B shows a simplified diagram illustrating network components of network **12** that may be replaced or added in existing cable networks to enable full duplex communication. Note that in some embodiments, such as N+m architecture with m=0 (e.g., N stands for number of nodes, m stands for number of amplifiers after each node), amplifiers **20** are not used at all. In an example embodiment, a majority (e.g., 97%) of taps and splitters **22** can be re-used for full duplex operation. This may be because standard tap and splitter combiner can operate in full band (e.g., 5-1000 MHz) for both upstream and downstream, supporting full-duplex communication in the supported frequency band. Only a minority (e.g., 3%) of taps and splitters **22** that do not support full band down-

stream and upstream may have to be replaced for full duplex communication. Likewise, because cable modems **16** are not operating in full duplex mode singly, they may be reused if they support the full band (e.g., they include capability to perform FDD with full agility for upstream and downstream frequencies). Components in network **12** that include diplexers (such as transceivers **18** and amplifiers **20**) may have to be replaced entirely to support full duplex communication.

In various embodiments, intelligent MAC scheduling may be used to avoid interference among neighboring cable modems **16**. Intelligent MAC scheduling can include: (i) ranging (e.g., measuring and/or monitoring interference among cable modems **16**, for example, by establishing interference groups **30**), and (ii) T-R coordination (e.g., transmissions and receptions are coordinated through a centric or distributed scheduler to avoid interference among cable modems **16**). In some embodiments, the T-R coordination implements a two dimensional (frequency and time) interference avoidance scheme.

Ranging facilitates assigning cable modems **16** to one or more interference groups **30**. In some embodiments, during ranging, each of cable modems **16** transmits an interference pattern upstream. For example, the interference pattern could comprise a single tone at one or more frequencies. Other cable modems **16** attempt to receive the interference pattern on their downstream reception frequencies. Different frequencies and/or marked tones for the interference pattern may facilitate many cable modems **16** using the same ranging frequency interval. In some cases, one cable modem may interfere with another, which interferes with a third cable modem, yet the third cable modem may not interfere with the first cable modem. For example, there may be cases in which CM_1 interferes with CM_2 , which interferes with CM_3 , but CM_3 does not interfere with CM_1 , leading to overlapping interference groups **30**. In one example embodiment, such overlapping groups may be lumped into one overarching group, with sub-groups therein.

In some embodiments, one of cable modems **16** may be scheduled to transmit on a specific frequency in a maintenance time window, and other cable modems **16** report their downstream modulation error ratio (MER) or interference level on that frequency to MAC scheduler **26** (or CMTS **14**, or other appropriate report receiving module in cable network **12**). Based on the reported downstream MER or interference level (as the case may be), a determination may be made as to which cable modems **16** are interfered by the transmitting one of cable modems **16**. The interfered cable modems **16** are associated with the transmitting one of cable modems **16** on that frequency in a particular one of interference groups **30**. The process may be repeated for various frequencies and cable modems **16**. Interference groups **30** may not be updated often. Updating interference groups **30** comprises informing cable modems **16** categorized in respective interference groups **30** as to their membership. Membership of cable modems **16** may change due to various environmental conditions, network load balancing, bandwidth usage by particular CMs, and other factors. In some embodiments, interference groups **30** may be updated when there are changes to Hybrid fiber-coaxial (HFC); in other embodiments, interference groups **30** may be updated after a predetermined time interval (e.g., 24 hours).

In some embodiments, intelligent MAC scheduler **26** implements static frequency planning for T-R coordination. Spectrum sharing may be implemented through dynamic transmission coordination to avoid interferences. To explain interferences, consider upstream transmission from CM_1 . The upstream transmission from CM_1 may be coupled into

CM_2 at a common tap-splitter **22** with limited isolation and cause interference with downstream reception at CM_2 . The interference from CM_1 cannot be cancelled out at CM_2 as CM_2 does not have any reference signal from CM_1 (e.g., CM_2 cannot determine whether downstream reception at CM_2 is from CMTS **14** or from CM_1).

To reduce interferences at cable modems **16**, a CM frequency planning scheme is implemented in various embodiments. The frequency spectrum used in cable network **12** is divided into multiple frequency ranges that align with channel boundaries. For each one of cable modems **16** and each frequency range, those cable modems **16** are identified whose upstream transmissions interfere with downstream reception of that specific one of cable modems **16**, and those cable modems **16** whose downstream receptions are interfered by upstream transmissions of that specific one of cable modems **16**, if they operate on that same frequency (as is the case in full duplex communication). MAC scheduler **26** avoids assigning cable modems **16** to frequency ranges that cause interferences among them.

Full duplex communication affects operation of various components of cable network **12**, and the implications are different on different components. For example, the implications on CMTS **14** arise in the two areas: (a) full duplex involves CMTS **14** supporting throughputs of full band downstream traffic and upstream traffic (this is mainly a capacity specification to support the throughput); and (b) frequency planning and intelligent MAC scheduling, including establishing interfering/interfered lists according to algorithms described herein, executing frequency planning algorithms and determining frequency assignments, and T-R coordination as appropriate. In some embodiments, such functions can be integrated into MAC scheduler **26** at CMTS **14**.

In some embodiments, full duplex communication may involve a major re-design of transceiver **18**. Transceiver **18** may be reconfigured by replacing its diplexer with a 2-way combiner-splitter and other modifications. Transceiver **18** may be rewired to support full band operation for both downstream and upstream, and for high capacity to support the throughput of full band downstream and upstream. Transceiver **18** may also be changed to implement AIC algorithms. Other functions to support full duplex include: measuring interferences among cable modems **16** for frequency planning; and measuring cable modem downstream timing and upstream timing for supporting T-R coordination as appropriate.

Although cable modems **16** operate in FDD mode (e.g., downstream reception and upstream transmission on different frequencies in any one cable modem), cable modems **16** support full band FDD operation of both downstream and upstream. Full band FDD means downstream and upstream frequencies can be on any frequencies between 10 MHz to 1000 MHz (1.2 GHz) although they do not overlap each other. This means that cable modems **16** do not include any diplexer. In addition, cable modems **16** have full frequency agility, good RF fidelity (e.g., with minimized guard band between downstream and upstream), and high capacity to support full band throughput (e.g., 500 MHz DS and 500 MHz US).

Amplifier **20** may be subject to a major re-design to support full duplex communication. For example, amplifier **20** may be re-designed with no diplexer, full band operation, and digitized input signal. Interference cancellation blocks including ringing suppression may be added to existing amplification functions. Amplifier **20** implementing a two-step interference cancellation scheme can provide over 50

dB interference suppression and push the interference below the noise floor. However, some signal integrity degradation may be inevitable. For example, if the interference is suppressed to 6 dB below the system noise floor, there may be 1 dB degradation to signal's ratio of signal-to-noise ratio (SNR) to modulation error ratio (MER) (SNR/MER). In some embodiments, the maximum number of the cascaded amplifiers (including trunk, bridge and extender) may be limited to 5 (N+5, max 5 dB degradation at the end of the line), for example, to minimize signal degradation.

The optical link in HFC may be changed to support full duplex operation by providing high capacity for both DS and US to support the high throughput of coaxial network under full duplex. In a general sense, amplifiers in the coax network may be replaced. Devices with built-in diplexer (for example, reverse attenuator) in the coax network may be replaced (3% of taps, according to Cisco CATV market). System gain re-engineering/re-balance may be suitable due to the extended frequencies. Some of the devices may be replaced (with better port-to-port isolation) to enhance isolation among cable modems **16**. Occasionally, the coax network may be re-architected to enhance isolation among cable modems **16**. For example, an amplifier may be added right before a splitter to create isolated cable modem groups.

Full duplex could significantly increase cable access upstream throughput. An enabler for full duplex is interference cancellation and avoidance. Simulation results show that interference cancellation can be achieved through advanced digital signal processing algorithms. Full duplex is perpendicular to (e.g., orthogonal to, independent of, etc.) cable access technologies and high layer architectures; thus, it can work with any high level protocols and architectures. Full duplex can be used with existing access technology (CABU R-PHY shelf/node and CDBU CM), or as a candidate for next generation DOCSIS access technology. Full duplex is novel and substantial, and has business and technology impacts that may go beyond cable access (wireless, for example).

Turning to the infrastructure of communication system **10**, the network topology can include any number of cable modems, customer premises equipment, servers, switches (including distributed virtual switches), routers, amplifiers, taps, splitters, combiners and other nodes inter-connected to form a large and complex network. Network **12** represents a series of points or nodes of interconnected communication pathways for receiving and transmitting packets and/or frames of information that are delivered to communication system **10**. A node may be any electronic device, computer, printer, hard disk drive, client, server, peer, service, application, or other object capable of sending, receiving, amplifying, splitting, or forwarding signals over communications channels in a network. Elements of FIG. **1** may be coupled to one another through one or more interfaces employing any suitable connection (wired or wireless), which provides a viable pathway for electronic communications. Additionally, any one or more of these elements may be combined or removed from the architecture based on particular configuration needs.

Cable network **12** offers a communicative interface between cable network components, and may include any local area network (LAN), wireless local area network (WLAN), metropolitan area network (MAN), Intranet, Internet, Extranet, wide area network (WAN), virtual private network (VPN), or any other appropriate architecture or system that facilitates communications in a network environment. Network **12** may implement any suitable communication protocol for transmitting and receiving data packets

within communication system **10**. The architecture of the present disclosure may include a configuration capable of DOCSIS, TCP/IP, TDMA, and/or other communications for the electronic transmission or reception of signals in a network. The architecture of the present disclosure may also operate in conjunction with any suitable protocol, where appropriate and based on particular needs. In addition, gateways, routers, switches, and any other suitable nodes (physical or virtual) may be used to facilitate electronic communication between various nodes in the network.

In some embodiments, a communication link may represent any electronic link supporting a network environment such as, for example, cable, Ethernet, wireless technologies (e.g., IEEE 802.11x), ATM, fiber optics, etc. or any suitable combination thereof. In other embodiments, communication links may represent a remote connection through any appropriate medium (e.g., digital subscriber lines (DSL), coaxial fiber, telephone lines, T1 lines, T3 lines, wireless, satellite, fiber optics, cable, Ethernet, etc. or any combination thereof) and/or through any additional networks such as a wide area networks (e.g., the Internet).

Note that the numerical and letter designations assigned to the elements of FIG. **1** do not connote any type of hierarchy; the designations are arbitrary and have been used for purposes of teaching only. Such designations should not be construed in any way to limit their capabilities, functionalities, or applications in the potential environments that may benefit from the features of communication system **10**. It should be understood that communication system **10** shown in FIG. **1** is simplified for ease of illustration.

In particular embodiments, CMTS **14** may comprise a hardware appliance with appropriate ports, processors, memory elements, interfaces, and other electrical and electronic components that facilitate the functions described herein, including providing high speed data services, such as cable Internet or voice over Internet Protocol (e.g., in the form of digital, RF, or other suitable signals) to cable subscribers, such as cable modems **16**. In various embodiments, CMTS **14** comprises a Universal Broadband Router (uBR) with features that enable it to communicate with a Hybrid Fiber Coaxial (HFC) cable network via a suitable cable modem card, which provides an interface between the uBR protocol control information (PCI) bus and radio frequency (RF) signals on the DOCSIS HFC cable network.

In some embodiments, CMTS **14** may comprise a converged cable access platform (CCAP) core that transmits and receives digital signals in IP protocols, coupled with one or more physical interface (PHY) transceiver(s), such as transceiver **18** that convert the digital IP signals into RF signals, and vice versa. The PHY transceivers, such as transceiver **18**, may be co-located with the CCAP core at a common location, or may be located remote from the CCAP core and connected over a converged interconnect network (CIN). In some embodiments, CMTS **14** may comprise a single CCAP core and a plurality of PHY transceivers, such as transceiver **18**. CMTS **14** is connected (e.g., communicatively coupled, for example, through wired or wireless communication channels) to cable modems **16**, transceiver **18**, and amplifier **20** in cable network **12**.

In some embodiments, intelligent MAC scheduler **26** may comprise a hardware device or software application or combination thereof executing within CMTS **14** to facilitate spectrum sharing by cable modems **16**. In other embodiments, intelligent MAC scheduler **26** may comprise a hardware device or software application executing outside CMTS **14**, for example, in a separate appliance (e.g., fiber coaxial unit (FCU) access node, etc.), server, or other

11

network element and coupled to (e.g., connected to, in communication with, etc.) CMTS 14 in cable network 12.

Transceivers 18 may comprise suitable hardware components and interfaces for facilitating the operations described herein. In some embodiments, transceivers 18 may be embedded in or be part of another hardware component, such as a broadband processing engine comprising a motherboard, microprocessors and other hardware components. In some embodiments, transceivers 18 comprise downstream and upstream PHY modules, deployed in a Coaxial Media Converter (CMC) that supports RF functions at the PHY layer. Transceivers 18 may comprise pluggable modules (e.g., small form-factor pluggable (SFP)) that may be plugged into a network element chassis, or embedded modules that attach to cables directly. In addition to optical and electrical interfaces, transceivers 18 include a PHY chip, appropriate digital signal processors (DSPs) and application specific integrated circuits (ASICs) according to particular needs. In various embodiments, the DSPs in transceivers 18 may be adapted (e.g., programmed) to perform appropriate interference cancellation as described herein to enable full duplex communication.

Amplifiers 20 comprise RF amplifiers suitable for use in cable network 12. Amplifiers 20 are typically used at intervals in network 12 to overcome cable attenuation and passive losses of electrical signals caused by various factors (e.g., splitting or tapping the coaxial cable). Amplifiers 20 may include trunk amplifiers, distribution amplifiers, line extenders, house amplifier and any other suitable type of amplifier used in cable networks. According to various embodiments, substantially all amplifiers 20 are configured suitably as described herein to facilitate full duplex communication.

Turning to FIG. 2, FIG. 2 is a simplified diagram illustrating example details of frequency planning by MAC scheduler 26 according to an example embodiment of communication system 10. Various frequency ranges used by cable modems 16 in any one of interference groups 30 may be divided in time into resource blocks, such as upstream resource blocks 32, downstream resource blocks 34 and guard time resource blocks 36. In a general sense, the time and frequency employed to transmit an amount of data may be grouped as a resource block. In some embodiments, each resource block may comprise 8 or 16 symbols in time, and 1 subcarrier in frequency. The frequency division aligns with channel boundaries in some embodiments. In other embodiments, the frequency division has finer granularities, such as corresponding to groups of subcarriers for DOCSIS 3.1. The time division aligns with frame boundaries in some embodiments. In other embodiments, the time division aligns with mini-slots boundaries. In various embodiments, upstream resource blocks 32 and downstream resource blocks 34 in the relevant interference group do not synchronize on the time division boundaries; there is no overlap between upstream transmission and downstream receptions in frequency-time space within the same interference group.

In some embodiments, a centric scheduler algorithm may be used to achieve T-R coordination with the described resource allocation scheme. Other embodiments use a distributed scheduler algorithm for T-R coordination. With the centric scheduler algorithm, the resource scheduling in time and frequency is done centrally, for example, with MAC scheduler 26 in CMTS 14. In the distributed scheduler algorithm, the upstream scheduling is done mainly by cable modems 16 through a contention scheme. CMTS 14 assists the upstream scheduling by policing resource usage by cable modems 16 to avoid the collision. In other words, it is a

12

contention based upstream scheduling with collision avoidance. The distributed scheduler algorithm is similar in some ways to the centric scheduler algorithm, in that the distributed algorithm divides the available bandwidth into resource blocks, and follows the rule of no overlapping of downstream resource blocks 34 and upstream resource blocks 32 within any one of interference groups 30.

A simplex bi-directional signaling channel is established between CMTS 14 and cable modems 16 to exchange scheduling information. CMTS 14 broadcasts the downstream resource block allocation information comprising a downstream media access protocol (MAP) message to cable modems 16 in the signaling channel ahead of the actual allocation time. Cable modems 16 listen to the downstream MAP in the signaling channel. Based on the downstream MAP, cable modems 16 sort out upstream resource blocks 32 available for upstream transmission. In various embodiments, a specific downstream MAP message may be applicable to (e.g., correspond with) a particular one of interference groups 30. Based on queue depth (e.g., amount of data queued to be transmitted), cable modems 16 reserve upstream resource blocks 32 by sending a reservation notice to CMTS 14. CMTS 14 echoes the cable modems' reservations in a downstream signaling channel with time stamps. Each of cable modems 16 receives an echo of its own reservation and reservation of other cable modems 16, with time stamps. The specific one of cable modems 16 with the earliest time stamp for its reservation may seize upstream resource blocks 32 and start transmitting.

The downstream and upstream scheduling are not independent of each other. For a specific one of cable modems 16, MAC scheduler 26 may schedule its upstream transmission in certain upstream resource blocks 32; further, MAC scheduler 26 may ensure that other cable modems 16 from the same interference group receive their downstream receptions in downstream resource blocks 34 that do not overlap with scheduled upstream resource blocks 32 of the specific one of cable modems 16. Likewise, for the specific one of cable modems 16, MAC scheduler 26 may schedule its downstream reception in certain downstream resource blocks 34; further, MAC scheduler 26 may ensure that other cable modems 16 from the same interference group transmit upstream in upstream resource blocks 32 that do not overlap with the scheduled downstream resource blocks 34. Multicast and broadcast messages may be scheduled on specific resource blocks without upstream transmission from any cable modems 16. In the case of broadcast video, a block of downstream spectrum (e.g., frequency range) may be allocated for broadcast video, and the corresponding upstream spectrum may be idled to avoid interference to video at cable modems 16.

Turning to FIG. 3, FIG. 3 is a simplified diagram illustrating example details of T-R coordination according to an embodiment of communication system 10. Consider T-R coordination among two CMs, CM_1 and CM_2 in a particular one of interference groups 30 in cable network 12. MAC scheduler 26 may allocate resource blocks 38 to CM_1 and resource blocks 40 to CM_2 . Note that for ease of illustration, upstream resource blocks and downstream resource blocks comprised in resource blocks 38 and 40 are not explicitly shown. MAC scheduler 26 will not schedule CM_2 to transmit upstream on the same frequency at the same time when CM_1 is receiving downstream. In other words, CM_1 and CM_2 do not have overlapping resource blocks for upstream transmission or downstream reception. Such pairwise relationship holds for any pair of cable modems 16 in any one of interference groups 30.

Turning to FIG. 4, FIG. 4 is a simplified block diagram illustrating example details of an embodiment of communication system 10. In some embodiments, MAC scheduler 26 may operate centrally in cable network 12, implementing T-R coordination centrally, for example, at CMTS 14. MAC scheduler 26 categorizes cable modems 16 into interference groups 30, and schedules upstream transmissions and downstream receptions for cable modems 16 in each interference group 30, such that no cable modem of any one interference group transmits upstream in a frequency range simultaneously as another cable modem in the same interference group receives downstream in the frequency range. The scheduling can allow cable modems 16 in different interference groups 30 to transmit upstream and receive downstream simultaneously in the frequency range. MAC scheduler 26 generates scheduling information of the scheduling. The scheduling information may be comprised in appropriate MAC control messages in some embodiments. MAC scheduler 26 transmits the scheduling information to cable modems 16.

In various embodiments, downstream reception time is interleaved in a zig zag pattern such that downstream data spans multiple symbols overlapped with each other. In a general sense, “interleaving” refers to spreading data over some parameter; data spread over time is referred to as time interleaved data; data spread over frequency is referred to as frequency interleaved data. For example, data comprised in one symbol before interleaving is spread across 32 symbols after interleaving. Note that the term “symbol” has the general meaning familiar to persons with ordinary skill in the art and refers to a time interval for communicating bits of data that are modulated onto carriers at certain frequencies according to the modulation scheme used for the communication (e.g., in a single carrier modulation scheme, as higher data rates are used, the duration of one symbol becomes smaller); data is coded into the frequency domain one symbol at a time. In other words, data is carried in communication channels in cable network 12 in units of symbols in the time domain and frequency sub-carriers in the frequency domain.

Prior to interleaving, subsequent symbols containing downstream data are not overlapped; after interleaving, the downstream data spans multiple symbols and is effectively overlapped with itself. In an example, a packet of data that fits into one or two symbols occupies 32 symbols after interleaving. In various embodiments, upstream transmission time is not interleaved. In various embodiments, downstream transmission frequency is interleaved across a downstream symbol spanning a frequency range of an orthogonal frequency division multiplex (OFDM) resource block (e.g., 192 MHz) (and not the entire frequency spectrum available for cable network 12). Upstream transmission frequency is interleaved across an upstream symbol. The upstream symbol is aligned with the downstream symbol.

To facilitate interleaving in the time and frequency domain, interference groups 30 may be further sorted into interference blocks (IBs) 42. Each interference block 42 comprises a plurality of symbols including a symbol for guard time, with interleaving being implemented using interference blocks 42. In some embodiments, cable modems 16 may be sorted into interference groups 30 at initialization using a special ranging process. Interference groups 30 are sorted into interference blocks 42. Note that interference blocks 42 can comprise any suitable (e.g., convenient, appropriate) grouping of interference groups 30. In an example embodiment, interference blocks 42 may be designated by small letters a, b, c, d, for example, to

distinguish them from DOCSIS 3.1 profile designations of capital letters A, B, C, D. In an example embodiment, any one interference block 42 may equal 32 symbols (comprising the interleaved symbols) and one additional symbol for guard time, totaling 33 symbols in all. The guard time symbol may not be a dedicated symbol, but may be conveniently chosen based on the data pattern or other parameters as appropriate.

In some embodiments, a number (e.g., 100) of interference groups 30 may be mapped to a relatively much smaller number (e.g., 4) of interference blocks 42. In other embodiments, a number of interference groups 30 (e.g., 100) may be mapped to an equal or similar order of magnitude number of interference blocks 42 (e.g., 100 or 50). In the latter embodiments, each interference block 42 may serve as a guard time in downstream transmissions from CMTS 14 to cable modems 16. The upstream transmissions would ignore 3× interference block times (e.g., first interference block time during which it is supposed to receive downstream data, and two other interference blocks on either side of the first interference block time). With dynamic assignment of interference groups 30 to interference blocks 42, each interference group 30 can get 97% of the spectrum between downstream reception and upstream transmission. In a general sense, delay and timing differences within any one of interference groups 30 can be accommodated with a one symbol guard time, whereas delay and timing differences between CMTS 14 and interference groups 30 may be accommodated with additional guard time.

Turning to FIG. 5, FIG. 5 is a simplified block diagram illustrating example details according to an embodiment of communication system 10. Consider an example transmission comprising four interference blocks 42. In other words, interference groups 30 are categorized into 4 interference blocks 42 (e.g., 100 interference groups map to 4 interference blocks), namely, a, b, c, and d. Without time interleaving, interference blocks a, b, c, d may be stacked one after the other in a repeating pattern. With time interleaving, interference blocks a, b, c, and d may overlap with each other in time according to the extent of interleaving. In some embodiments, time offset may also be implemented, for example, with the next set of interference blocks 42 being some time apart from the previous set of interference blocks 42, for example, to account for time delays and other factors. Such time offset may include guard times to account for delays among cable modems 16, between CMTS 14 and cable modems 16, etc.

Turning to FIG. 6, FIG. 6 is a simplified block diagram illustrating example details according to an embodiment of communication system 10. In non-full-duplex cable networks, a cyclic prefix (CP) is different for the downstream symbol and the upstream symbol because they are at different frequencies. However, with full duplex communication, the downstream symbol and upstream symbol can be at the same frequency. In various embodiments, the CP is the same for a particular frequency, regardless of the direction (e.g., upstream or downstream) of transmission, facilitating alignment of downstream and upstream symbols per OFDM resource block. In some embodiments, the time-space alignment of downstream symbols with upstream symbols can be represented figuratively by trapezoids in the downstream lining up with rectangles in the upstream direction. The “bottom” side of the trapezoid would be different in length from the “top” side depending on the amount of time interleaving. In such a figurative representation, the top of the downstream trapezoid would be zero interleaved and can be considered a reference point.

Consider an example transmission comprising four interference blocks **42**. In other words, interference groups **30** are categorized into 4 interference blocks **42** (e.g., 100 interference groups map to 4 interference blocks), namely, a, b, c, and d. In such example embodiments, if all interference blocks **42** are of equal bandwidth, then each interference group **30** is only getting 25% of the frequency spectrum.

Each interference block **42** is 33 symbols wide in this example. Assume that interference blocks **42** allocated for downstream transmission are referred to as downstream blocks **44** in pattern a-b-c-d-repeat; interference blocks **42** allocated for upstream transmission are referred to as upstream blocks **46** in pattern c-d-a-b-repeat. Downstream blocks **44** could be lined up with the upstream blocks **46** with an offset of 2 blocks. The gap between blocks a and c is the guard time (comprising blocks b and d). The guard time is at least 32 symbols wide to accommodate downstream frequency interleaving. An extra symbol is included to allow for time differences within an interference group for a total of 33 symbols.

Turning to FIG. 7, FIG. 7 is a simplified block diagram illustrating example details according to an embodiment of communication system **10**. In a general sense, when a time domain interleaving scheme is typically implemented at the symbol level, different carriers of the OFDM symbol are delayed by different amounts. As the carrier allocation is along frequency, the interleaving in time will be effective for burst interferences; the interferences will be spread across the symbols in time axis, into multiple forward error correction (FEC) blocks. In the case where the burst interference covers many sub-carriers, the interleaving depth is large enough to minimize the numbers of interfered sub-carriers for each FEC block. However, time interleaving introduces delay, which equals the interleaving depth.

According to some embodiments, interleaving **50** takes advantage of the multiple FEC blocks along frequency at each symbol. Time interleaving **52** is performed on the symbols, and frequency interleaving **54** is added to time interleaving **52**, for example, to achieve better interleaving efficiency with minimized delay. Accordingly, symbols at each symbol time are re-arranged through a simple storage access scheme without introducing any delay. With addition of frequency interleaving **54** to time interleaving **52**, effective interleaving depth is a product of frequency interleaving depth and time interleaving depth. Interleaved data is subjected to Inverse Fast Fourier Transform (IFFT) and sent across a burst channel. At the receiver, the received data is subjected to Fast Fourier Transform (FFT) and frequency de-interleaving **56**, followed by time de-interleaving **58**.

Turning to FIG. 8, FIG. 8 is a simplified block diagram illustrating example details according to an embodiment of communication system **10**. According to the embodiments interleaving **50**, in which time interleaving **52** is added to frequency interleaving **54**, interferences fall into different FEC blocks after de-interleaving even with shallow interleaving depth along time, leading to enhanced interleaving performance with a minimum delay.

Turning to FIG. 9, FIG. 9 is a simplified block diagram illustrating example details of frequency interleaving **54** according to an embodiment of communication system **10**. Consider a hypothetical example comprising a mapping **60** between symbols **62** and sub-carriers **64**. Twelve symbols **62** are mapped to corresponding twelve sub-carriers **64** in mapping **60**. According to frequency interleaving **54**, sub-carriers **64** are arranged into two columns and are ordered in an ascending order along each of the columns (e.g., 1-6 in column 1 and 7-12 in column 2). Sub-carriers **64** are

re-ordered by reading the rows of the two columns in an ascending order (e.g., bottom to top). The final order of sub-carriers **64** after frequency interleaving **54** is no longer in a purely ascending order. Final mapping **66** between symbols **62** and sub-carriers **64** is different from mapping **60** before frequency interleaving **54**.

Turning to FIG. 10, FIG. 10 is a simplified block diagram illustrating example details of interleaving **50** according to an embodiment of communication system **10**. To explain further, consider an example with 16384 sub-carriers (192 MHz, 12.5 kHz CS). The 16384 sub-carriers are arranged into 8 columns, each column having 2048 sub-carriers. With 16200 bit-density parity-check (LDPC) and 256-Quadrature amplitude modulation (QAM), each column has one FEC codeword (CW). At the interleaving stage, mapping between symbols and sub-carrier is such a way that the symbols are written along columns, and read out along rows. At the de-interleaving stage, symbols are written along rows, and read out along columns.

Turning to FIG. 11, FIG. 11 is a simplified flow diagram illustrating example operations **70** according to an embodiment of communication system **10**. Operations **70** may be assumed to be executed at a specific one of cable modems **16**. In some embodiments, a distributed intelligent scheduling scheme is implemented by MAC scheduler **26** for T-R coordination, for example, to make the scheduling scheme more scalable. The distributed intelligent scheduling is enforced by cable modems **16** and is not centrally enforced at CMTS **14**. The distributed scheduling scheme keeps the downstream and upstream scheduling asynchronous with each other.

In general, according to the distributed scheduling scheme, cable modems **16** are divided into a large number of interference groups **30**, each having a relatively small number of cable modems **16**. Interference groups **30** are established with a ranging process. Downstream transmission in a frequency range from CMTS **14** to cable modems **16** is implemented in one or more transmission units, such as FEC CW. Each FEC CW includes a group label identifying the specific interference group that is receiving data for that FEC CW, distinguishing the downstream transmission in the frequency range to the interference group from downstream transmissions to other interference group. In an example embodiment, the FEC CW group label may be included in a FEC next codeword pointer field (NCP) according to DOCSIS 3.1 standards. At **72**, the cable modem executing operations **70** receive the FEC CW. At **74**, it identifies the target interference group from the group label in the FEC CW. At **76**, a determination is made whether the target interference group is the same as the local interference group to which the cable modem belongs. If the local interference group is not the target interference group, the FEC CW (and subsequent downstream transmission) may be disregarded at **78**.

If the local interference group is the target interference group, the cable modem determines the downstream reception time window at **80**. The group label in the FEC CW is several CW times in advance or in a separate structure so that the cable modem in the target interference group can anticipate receiving the downstream data ahead of actual reception, and schedule upstream transmission accordingly. At **82**, the cable modem makes a determination whether it has scheduled any upstream transmission during the anticipated time window. According to various embodiments, cable modems **16** in the target interference group receiving the FEC CW are not allowed to transmit upstream. Because cable modems **16** request bandwidth ahead of time of

upstream transmission, some cable modems **16** may have received a grant during the time window of downstream transmission. (CMTS **14** is not enforcing scheduling restrictions, and freely issues grants.) Thus, the determination at **82** may include identifying any grants available for use during the anticipated time window.

If no upstream transmission is scheduled, at **84**, the cable modem schedules upstream transmission outside the anticipated time window (e.g., prior to, or after, the anticipated time window). At **86**, the cable modem associates minislots or symbols times in upstream transmissions with minislots or symbols in downstream receptions, aligning upstream and downstream symbols. On the other hand, if upstream transmission is scheduled, at **88**, the cable modem suppresses upstream transmission during the anticipated time window, forfeiting the upstream transmission opportunity. At **90**, the forfeiture can be managed by re-issuing requests to CMTS **14** with higher priority. In some embodiments, CMTS **14** may poll target cable modems to which it is sending downstream transmissions to check on suppressed transmissions.

In some embodiments, downstream bandwidth per cable modem being limited, downstream bandwidth per interference group can be rate-limited in a hierarchical manner to prevent upstream transmissions from being locked out. Embodiments of communication system **10** may not require any downstream and upstream calibration and alignment at CMTS **14**. Long guard times may also be unnecessary, for example, due to large serving area sizes. The reference is local to the cable modems **16** that are close enough to impact each other. In various embodiments, cable modems **16** are “warned” ahead of time of downstream transmission of data and can suppress upstream transmission accordingly.

Each one of interference groups **30** becomes a simplex group in which transmission occurs in one direction at a time. Because the sizes (e.g., memberships) of interference groups **30** are small and there are many of them, the overall effect in cable network **12** is full duplex communication. In various embodiments, any one cable modem has an aggregate bandwidth equal to one copy of the full spectrum. The overall interference group on a node has an aggregate bandwidth equal to two times the spectrum.

In some embodiments that include the distributed intelligent scheduling, a first interference group predicts that a particular frequency range is not going to be used for upstream transmission by a second interference group and hijacks the frequency range for its own upstream transmission. Prediction may be based upon traffic to one or more cable modems in the second interference group, priorities of traffic or devices, back-up list information from CMTS **14**, set of contention REQ slots, or other suitable parameters.

Turning to FIG. **12**, FIG. **12** is a simplified block diagram showing example details of MAC scheduler **26** according to embodiments of communication system **10**. MAC scheduler **26** includes a ranging scheduler **100**, a report receiver **102**, a MER analyzer **104**, a classifier **106**, an aggregator **108**, a frequency planner **110**, and a group generator **112**. Memory element **28** may store various data, including one or more interfered list **114**, a global interfered list **116**, one or more interfering list **118**, and a global interfering list **120**.

During frequency planning and grouping, MAC scheduler **26** may generate, for a particular one of cable modems **16** (say CM_1) in cable network **12**, interfered list **114** associated with a frequency range. Interfered list **114** comprises a first list of cable modems **16** whose downstream reception in the frequency range is interfered by upstream transmissions of cable modem CM_1 in the frequency range. Assume, merely for example purposes, that the first list of cable modems

comprises cable modems CM_2 and CM_3 . In other words, interfered list **114** for CM_1 comprises CM_2 and CM_3 . MAC scheduler **26** may repeat the interfered list generating process for other cable modems **16** (e.g., $CM_1 \dots CM_m$) in cable network **12**. For example, interfered list **114** for CM_2 may comprise CM_2 and CM_m ; interfered list **114** for CM_3 may comprise $CM_1 \dots CM_m$; etc.

The interfered list generating process is repeated for other frequency ranges in the frequency spectrum used in cable network **12**. For example, the frequency spectrum may be divided into n frequency ranges (e.g., $F(1)$ to $F(n)$), and the interfered list generating process may be repeated for each one of the n frequency ranges, with separate interfered lists **114** being generated for each frequency range and each cable modem in cable network **12**. Aggregator **108** may aggregate the generated interfered lists into global interfered list **116**.

MAC scheduler **26** may further generate, for one of cable modems **16**, say CM_1 , interfering list **118** associated with the frequency range. Interfering list **118** comprises a second list of cable modems whose upstream transmissions in the frequency range interfere with downstream reception of cable modem CM_1 in the frequency range. Assume, merely for example purposes, that the second list of cable modems comprises cable modems $CM_2 \dots CM_m$. In other words, interfering list **118** for CM_1 comprises $CM_2, CM_3, \dots CM_m$. MAC scheduler **26** may repeat the interfering list generating process for other cable modems **16** (e.g., $CM_1 \dots CM_m$) in cable network **12**. For example, interfering list **118** for CM_2 may comprise CM_1 and CM_3 ; interfering list **118** for CM_3 may comprise CM_2 ; etc. The interfering list generating process is repeated for other frequency ranges $F(1)$ - $F(n)$ in the frequency spectrum used in cable network **12**. Aggregator **108** may aggregate the generated interfering lists into global interfering list **120**.

In various embodiments, to generate interfered list **114** for cable modem CM_1 for a particular frequency range, say $F(1)$, ranging scheduler **100** schedules cable modem CM_1 to transmit a ranging signal within the frequency range $F(1)$ during a maintenance window (e.g., initial ranging window; contention window; etc.). Report receiver **102** receives reports indicative of interferences on respective downstream reception at the frequency from other cable modems $CM_2 \dots CM_m$ in cable network **12**. The reports include MER values. MER analyzer **104** analyzes the received reports and identifies cable modems CM_2 and CM_3 that are interfered by the transmitting cable modem CM_1 based on the reports. The identification may be based on the value of MER exceeding a predetermined threshold (either absolute or relative). For example, CM_2 and CM_3 may have reported the highest MER values among cable modems $CM_2 \dots CM_m$. Classifier **106** adds the identified cable modems CM_2 and CM_3 to the first list and into interfered list **114** for the cable modem CM_1 .

In various embodiments, generating interfering list **118** for the cable modem CM_1 (and other cable modems **16**) comprises deriving the second list of cable modems from global interfered list **116**. For example, for cable modem CM_1 and each frequency range, from global interfered list **116**, classifier **106** looks up the cable modems that interfere with the cable modem CM_1 on that frequency range. The interfering cable modems are entered as entries for the cable modem CM_1 on that frequency range in corresponding interfering list **118**. In various embodiments, interfering list **118** and interfered list **114** are not updated often; they may be updated when changes are made to cable network **12**, for example, additional cable modems are added, or existing cable modems are removed.

Frequency planner **110** assigns respective downstream reception frequency ranges and upstream transmission frequency ranges for cable modems **16** ($CM_1 \dots CM_m$) based on global interfered list **116** and global interfering list **120**. For example, CM_1 may be assigned downstream reception frequency range $F(1)$ and upstream transmission frequency range $F(3)$; CM_2 may be assigned downstream reception frequency range $F(3)$ and upstream transmission frequency range $F(n)$; and so on. In various embodiments, the assigning is on a first-come-first serve basis. For example, downstream reception frequency range may be selected from among the frequency ranges and assigned to the first available (e.g., recognized, identified, listed, sorted, etc.) unassigned cable modem to the exclusion of other cable modems based on global interfered list **116** and global interfering list **120**.

The assigning may be based on un-aggregated lists alternatively in some embodiments. Note that the aggregation operation is merely for convenience and may be skipped without departing from the scope of the embodiments. MAC scheduler **26** transmits to cable modems **16** ($CM_1 \dots CM_m$) corresponding assignment information comprising the respective assigned downstream reception frequency ranges and upstream transmission frequency ranges.

In some embodiments, group generator **112** groups cable modems **16** into interference groups **30**, each interference group being isolated on frequency basis from other interference groups, with cable modems in each group being assigned a common downstream reception frequency range and a common upstream transmission frequency range. For example, cable modems CM_1 , CM_2 and CM_3 may be assigned to group A. Cable modems CM_1 , CM_2 and CM_3 may be assigned a common downstream reception frequency range of $F(1)$ and a common upstream transmission frequency range of $F(2)$. In some embodiments, the grouping is based on interfered list **114**. For example, the cable modem CM_1 is grouped with the first list of cable modems comprising the cable modems CM_2 and CM_3 into interference group A for the frequency range $F(1)$. In other words, when grouping is based on interfered list **114**, downstream receptions of cable modems in each interference group for the corresponding frequency range are interfered by upstream transmissions of the cable modem in the corresponding frequency range.

In some embodiments, grouping may take advantage of the natural network architecture. For example, the cable modem CM_1 is grouped into interference group A with other cable modems CM_3 and CM_m connected to a commonly coupled amplifier in cable network **12**. In some embodiments, interference groups are further divided into a plurality of sub-groups with relative isolation among the sub-groups, for example, in which each sub-group comprises cable modems attached to a corresponding common tap (which is further down the network towards the cable modems than the common amplifier of the interference group). In various embodiments, cable modems in the interference group transmit upstream at a first frequency and receive downstream at a different frequency within the frequency range. For example, the cable modem CM_1 transmits upstream at frequency F_1 and receives downstream at frequency F_2 within frequency range $F(n)$.

Turning to FIG. **13**, FIG. **13** is a simplified block diagram showing example details of CM grouping according to an embodiment of communication system **10**. In various embodiments, cable modems **16** may be grouped into various interference groups **30** to enable full duplex communication with little to no interference. For the sake of simplic-

ity and ease of illustration, cable modems **16** are not shown explicitly in the figure, but are merely represented by one (or more) taps and splitters **22**. It may be appreciated that each tap/splitter **22** may be connected to one (or more) cable modems **16**. Interference groups **30** may comprise RF isolated groups that allow frequency re-use through intelligent MAC scheduling.

Interference groups **30** provide a basis for T-R coordination in various embodiments. In a general sense, the purpose of T-R coordination is to avoid interference among cable modems **16**. T-R coordination is a 2-dimensional resource allocation scheme that ensures that no CMs from the same interference group transmit simultaneously on a frequency that is being used by other CMs to receive data, and vice versa. The two dimensions comprise frequency and time.

In various embodiments, for a specific CM, its interference group is considered to be a group of CMs whose downstream receptions are interfered by the specific CM's upstream transmission. Interference groups could be frequency dependent. For example, in interference group A, cable modems **16** transmit upstream at frequency $F1$, and receive downstream at frequency $F4$, which is different from $F1$; in interference group B, cable modems **16** transmit upstream at frequency $F5$, and receive downstream at frequency $F2$; and so on. Cable modems **16** may belong to multiple interference groups, one for each frequency (e.g., carrier). In some embodiments, the interference may not be symmetric: a specific CM may interfere with another CM, but not the other way around. In other embodiments, the interference may be symmetric, with two CMs interfering with each other. For simplicity, relevant cable modems **16** (either interfere with or are interfered by, on any frequency) could be grouped into a single interference group. Cable modems **16** within each group tend to interfere with each other, but there are no or little interferences among cable modems **16** in different groups.

CMs that are within the same interference group may interfere with each other. That is, the upstream signal may not be sufficiently attenuated to be subtracted out of the combined spectrum. In some embodiments, the interference group may comprise CMs within the same tap group. Since there is no way of exactly knowing which CM is on which tap group, this has to be measured and the resulting groupings may not align exactly with a particular (e.g., single) tap group.

In an example embodiment, the frequency spectrum of cable network **12** may be divided into multiple frequency ranges. In some embodiments, each frequency range aligns with a channel boundary. For each specific one of cable modems **16** and each frequency range, MAC scheduler **26** may identify those cable modems **16** whose upstream transmissions interfere with downstream receptions of that specific one of cable modems **16**, and those cable modems **16** whose downstream receptions are interfered by upstream transmissions of that specific one of cable modems **16**, if they operate on that same frequency. Based on such identification, MAC scheduler **26** avoids assigning cable modems **16** to frequency ranges that may cause interferences among them. Cable modems **16** operate with FDD and no neighboring cable modems **16** are assigned to overlapping downstream and upstream frequency ranges.

Turning to FIG. **14**, FIG. **14** is a simplified block diagram showing further example details of CM grouping according to an embodiment of communication system **10**. In some embodiments, frequency planning can leverage isolations resulting from natural CM grouping in cable network **12**. Note that cable network topology is largely driven by street

and house layout and may vary dramatically from one community to others. The device performances (e.g., coupling, directivities, etc.) that dictate interference among cable modems **16** also vary in a wide range. Typically, distribution cables are branched out at the output of amplifier **20** (e.g., tree architecture). Taps and splitters **22** at amplifier **20** may provide approximately 20 dB isolation among cable modems **16** of each branch (e.g., division), whereas interference between downstream and upstream signals may be approximately 30 dB, permitting CMs in different groups to interfere only minimally, if at all. CMs covered by a single branch may belong to a single group in some embodiments. For example, two groups A and B of CMs that branch off after amplifier **20** may be unlikely to interfere with each other (cable modems **16** in group A will not interfere with cable modems **16** in group B and vice versa).

Turning to FIG. **15**, FIG. **15** is a simplified block diagram showing further example details of CM grouping according to an embodiment of communication system **10**. Multiple levels of CM grouping may be implemented in cable network **12**. CMs belonging to a single one of interference groups **30** could be further divided into multiple sub-groups **31**. For example, consider CM groups A and B, with CMs in group A transmitting upstream at frequency F1 and receiving downstream at frequency F2, and with CMs in group B transmitting upstream at frequency F2 and receiving downstream at frequency F1. Some cable modems **16** in group A that are attached to tap P are assigned to sub-group X; other cable modems **16** in group B that are attached to tap Q are assigned to another sub-group Y. The interferences among CMs belonging to different sub-groups X and Y may be much less compared to interferences among CMs within the same sub-group (say, X or Y, individually).

According to various embodiments, CM grouping based on frequencies that take advantage of natural network architecture can improve isolation among cable modems **16**, and enable full duplex operation through frequency planning. CM load balancing among groups may be achieved through sub-level grouping. For example, cable modems **16** may be load balanced among groups A and B by looking into sub-level grouping, and moving sub-groups cross groups. For example, sub-group Z initially assigned to group A may be regrouped into group B based on CM load balancing concerns. In some embodiments, frequency planning is automated, with CM load balance as one of the metrics for automation.

Turning to FIG. **16**, FIG. **16** is a simplified diagram illustrating example details of interfered list **114** of a frequency planning scheme according to an embodiment of communication system **10**. As such, a stochastic simulation scheme with an abstract model for cable network **12** may be used in some embodiments to simulate the frequency planning scheme. For example, cable network **12** is modeled by two lists: interfering list **118** and interfered list **114**. Regardless of the cable topology and device performance, the frequency planning depends substantially on the two lists; in other words, relevant properties of the network topology and devices may be substantially fully captured by the two lists.

Example interfered list **114** may be generated for each cable modem and each frequency range in cable network **12**. For example, the frequency spectrum may be divided into n frequency ranges and interfered list **114** generated for each one of cable modems **16** for each of the n frequency ranges. Interfered list **114** may be sorted according to frequency ranges in some embodiments, as shown in the FIGURE. For example, for frequency range F1, downstream reception of

cable modems CM'1_1, CM'1_2, . . . CM'1_n is interfered by upstream transmission of cable modem CM **1**; downstream reception of cable modems CM'2_1, CM'2_2, . . . CM'2_n is interfered by upstream transmission of cable modem CM **2**; and so on. Similar lists may be generated for each of frequency ranges F1, F2, . . . Fn. In some embodiments, the different lists may be collapsed into a single list, such as global interfered list **116** for example, for convenience.

Turning to FIG. **17**, FIG. **17** is a simplified flow diagram illustrating example operations **130** for frequency planning that may be associated with an embodiment of communication system **10**. Initially, global interfered list **116** and global interfering list **120** are generated. The operations may start at **132**, at which a cable modem CM(i) is selected with index i initialized to 1 in the first iteration. At **134**, frequency range F(j) is selected as the downstream reception frequency range to selected CM(i), with index j initialized to 1 in the first iteration. In other words, the first available cable modem is tentatively assigned the first selected frequency range in the first iteration. At **136**, cable modems that may interfere with CM(i) is identified by looking up the corresponding entry for CM(i) in interfering list **118** for F(j).

At **138**, a determination is made whether any of the identified cable modems have been assigned F(j) as the upstream transmission frequency. If yes, at **140**, a determination is made whether the selected frequency range F(j) is the last block of available frequency ranges; that is, whether frequency index j is equal to the maximum value of number of frequency ranges, n. If yes, CM(i) is tagged at **142** as not supporting full duplex communication (symmetrical is the same as full-duplex communication as used herein). The operations step to **144**, at which a determination is made whether the selected cable modem CM(i) is the last available cable modem (in other words, whether index i is equal to the maximum value of number of cable modems, m). If not, at **145**, cable modem index i is incremented by 1, and the operations step to **132** and continue thereafter. If the selected cable modem CM(i) is the last available cable modem, a determination is made at **146** whether the iteration is the maximum number of allowed iterations. If not, the operations continue to **132** with a new frequency index permutation. Otherwise, the operations end. Turning back to **140**, if the frequency index j is not n, it is incremented by 1 at **147**, and the operations step to **134** and continue thereafter. Turning back to **138**, if no cable modems have been assigned F(j) as the upstream transmission frequency, at **148**, F(j) is assigned as the downstream reception frequency for CM(i).

At **150**, F(j') is selected as the upstream transmission frequency for cable modem CM(i), with j' initialized to 1 in the first iteration. At **152**, cable modems are identified that may be interfered by CM(i) by looking up the corresponding entry for CM(i) in interfered list **114** for F(j'). At **154**, a determination is made whether any of the identified cable modems have been assigned a downstream reception frequency range of F(j'). If yes, at **156** a determination is made whether the selected frequency range F(j') is the last block of available frequency ranges; that is, whether frequency index j' is equal to the maximum value of number of frequency ranges, n. If yes, at **158**, CM(i) is tagged as not supporting full duplex communication, and the operations step to **144** and continue thereafter. If the frequency index j' is not n, it is incremented by 1 at **159**, and the operations step to **150**. Turning back to **154**, if no cable modems have been assigned F(j') as the downstream transmission frequency

range, at **148**, $F(j)$ is assigned as the downstream reception frequency range for CM(i) at **160**. The operations step to **144** and continue thereafter.

In various embodiments, operations **130** may not be fully optimized; for example, downstream reception and upstream transmission frequency ranges are assigned on a first-come-first-serve (FCFS) basis. As different cable modems may have different interfere characteristics (e.g., some may interfere with more cable modems, some less), FCFS may not result in an optimized frequency assignment (e.g., many cable modems may fail to support full duplex communication). To more fully exploit isolations among cable modems, the frequency ranges may be assigned such that cable modems with better isolations are grouped together and assigned with the same frequency range, leaving more frequency ranges for cable modems that require different frequency ranges to avoid interferences. In some embodiments, the iterations may be performed assigning each cable modem with each of the frequency ranges $F(1) \dots F(n)$ for both downstream reception and upstream transmission, and the best combination of frequency ranges (e.g., one with the least number of interfered cable modems) may be selected as the final assignment. However, to cover all the cable modems, and all the frequencies, for both downstream reception and upstream transmission, the total number of the iterations required to final assignment is $(n \cdot m)^2$, where n is the number of frequency ranges, and m is the number of cable modems. With $n=6$, $m=128$, there will be total $1.6096e^{199}$ iterations, which may not be practical with existing processors.

In some embodiments, a sub-optimal scheme may be implemented, in which the frequency index is permuted, and the frequency assignments are based on first-come-first-serve with respect to the cable modems, but with the permuted frequency index. The frequency assignment iterations are executed multiple times, each time with different, randomly selected frequency ranges, and the best combination of downstream and upstream frequency ranges are selected from the completed iterations. Simulations show that an optimal performance can be achieved with approximately 200 frequency permutations. The frequency planning (with the optimization step) can be tedious, but it may occur infrequently (e.g., frequency assignment may be performed only if there are changes to the network, such as addition of new taps, cable modems, etc.). In some embodiments, the frequency assignment may be performed offline, for example, with a software designed networking (SDN) application.

Turning to FIG. **18**, FIG. **18** is a simplified block diagram illustrating example details of transceiver **18** according to an embodiment of communication system **10**. In various embodiments, each of downstream and upstream signals uses the complete frequency spectrum during full duplex communication. As a result, a transmitted signal **162** (comprising downstream data from CMTS **14** to cable modems **16**) and a received signal **164** (comprising upstream data from cable modems **16** to CMTS **14**) overlap in frequency and time at transceiver **18**. Typically, transmitted signal **162** has a higher signal level (e.g., with more power) than received signal **164**, and can completely wipe out received signal **164** if there is not sufficient isolation between a transmitter portion **166** and a receiver portion **168** of transceiver **18**. In various embodiments, to enable full duplex communication in cable network **12**, interferences from transmitter portion **166** may be suppressed at receiver portion **168** using an AIC algorithm implemented in a DSP **170** in transceiver **18**. DSP **170** includes a memory element for

storing instructions and data appropriately. A clock module **171** facilitates timing functions for the AIC algorithm. In various embodiments, clock module **171** may be embedded in DSP **170**. DSP **170** may be configured to perform FFT/IFFT or other standard DSP operations. Embedded processors for control operations and I/O operations, with support for floating point operations may also be included in DSP **170**.

Interference is a limiting factor in quality of full duplex communications. Different from background noise, distortion effect of self-interference cannot be mitigated by increasing transmission power because the amount of interference is directly proportional to the signal power itself. OFDM scheme suffers from interference especially when time variation exists in the channel between transmitter portion **166** and receiver portion **168**.

In various embodiments, interferences coupled to receiver portion **168** arise from transmitter portion **166** due to full duplex communication, in which downstream and upstream frequencies overlap. In theory, transmitted signal **162** is known to, or can be accessed by, receiver portion **168** in transceiver **18**; ideally, a copy of transmitted signal **162** may be used as a reference signal to cancel out interferences at receiver portion **168**. However, the copy of transmitted signal **162** received by receiver portion **168** as the reference is an "ideal" transmitted signal, without any channel effect (e.g., micro-reflections), whereas the actual interference coupled through receiver portion **168** has channel effects. In various embodiments, the AIC algorithm executing in DSP **170** estimates the channel effects of transmitted signal **162** through a channel estimation algorithm. Receiver portion **168** imposes the estimated channel effects onto the ideal copy of transmitted signal **162**, and uses the modified copy of transmitted signal **162** to cancel out the interference.

Turning to FIG. **19**, FIG. **19** is a simplified block diagram illustrating example details of transceiver **18** according to an embodiment of communication system **10**. On a downstream pathway **172**, an OFDM signal baseband generator (not shown) generates a baseband reference signal. In an example embodiment, the baseband reference signal comprises a pseudo-random binary sequence (PRBS) signal with a bandwidth of 12.8 MHz, at a clock rate of 20.48 MHz with OFDM characteristics including subcarrier spacing of 20 kHz, Fast Fourier size of 1024, and a cyclic prefix up to 1.2207 μ s (e.g., 25 time-domain samples). In some embodiments, an external interface with an external OFDM signal generator inputs data to be transmitted in the OFDM baseband reference signal. In some embodiments, the baseband signal with data is up sampled by 20 times to 409.6 MHz, for example, to tune to any desired location in a frequency spectrum from 0 MHz to 150 MHz. The 20 time oversamples are split into 3 steps of 5 times, 2 times and 2 times, respectively, with half band harmonics suppression filtering. A quadrature modulator modulates the oversampled signal to generate a digital baseband OFDM signal **174** (for the sake of brevity, digital baseband (BB) OFDM signal may alternatively be referred to as simply BB signal).

BB signal **174** is provided as a reference signal to an AIC module **176** (e.g., implemented in DSP **170**). AIC module **176** comprises a block of instructions implementing an appropriate AIC algorithm. BB signal **174** is further converted to RF signal **162** at a digital to analog converter (DAC) **177**; an amplifier **178** amplifies RF signal **162**. A two-way combiner-splitter **179** transmits amplified RF signal **162** out of transceiver **18** on downstream pathway **172**.

Transmitted RF signal **162** may be reflected back to transceiver **18** on an upstream pathway **180** in one or more

frequencies that overlap with those of signals in upstream pathway **180** due to full duplex operation. Upstream pathway **180** refers to portions of transceiver **18** that include communication pathway of upstream signals (to CMTS **14** from cable modems **16**). Thus, the reflected signal may interfere with another upstream transmission (e.g., from cable modems **16**) on upstream pathway **180**, generating RF signal **164**, comprising the upstream transmission interfered by the reflected signal. In various embodiments, it may be desirable to extract the upstream transmission without the interferences from the reflected signal.

RF signal **164** may be received at two-way combiner-splitter **179**. A portion of received RF signal **164** may be reflected back on downstream pathway **172**, interfering with RF signal **162** generating an RF reference signal **182**, which is provided to AIC module **176** as a digital signal after conversion by an analog-to-digital converter (ADC) **183**. On upstream pathway **180**, received RF signal **164** is amplified by an amplifier **184**, converted to a digital signal by an ADC **185** and fed to AIC module **176**.

AIC module **176** reduces interferences in RF signal **164** from the reflected signal based on BB reference signal **174** and RF reference signal **182**, producing desired signal **186** as output. In a general sense, a channel impulse response can be measured from BB reference signal **174** and RF reference signal **182**. In various embodiments, AIC module **176** executes the AIC algorithm and cancels out interferences in received RF signal **164** from transmitted RF signal **162**. In some embodiments, prior to interference cancellation, RF signal **164** may be processed through a quadrature demodulator and subjected to decimation, at which the received 409.6 intermediate frequency (IF) signal is decimated by 20 times to a 20.48 MHz base band signal. In some embodiments, the 20 time decimations are split into three steps of 2 times, 2 times and 5 times respectively, with half band aliasing filtering. Harmonic suppression filters used at over sampling is reused as anti-aliasing filters.

In various embodiments, interference-canceled signal **186** is subjected to demodulation and fed to an OFDM signal receptor (not shown). OFDM signal reception after interference cancellation may include the following features: time tracking, frequency tracking (e.g., which may not be used if transmitter portion **166** and receiver portion **168** share the same system clock **171**), channel estimation, cyclic prefix removal, Inverse Fast Fourier Transform (IFFT), constellation computation and MER computations. In some embodi-

ments, the OFDM signal processing portion of receiver portion **168** may be implemented offline in an external computing device. The interference-canceled signal may be sent to the external computing device and post-processed with appropriate post processing algorithms.

Turning to FIG. **20**, FIG. **20** is a simplified block diagram illustrating example details of transceiver signal flows and interference cancellation according to an embodiment of communication system **10**. Transmitted RF signal **162** on downstream pathway **172** can loop back via multiple pathways. In general, transmitted RF signal **162** is reflected back to transceiver **18** from cable network **12**. For example, one of the reflections may be through port coupling of two-way combiner-splitter **179**; other reflections may occur at taps/splitters **22** from signal ringing at the respective taps/splitters **22**. The reflected signal comprises time-shifted samples of transmitted RF signal **162**, each time-shifted sample attenuated by differing amounts relative to transmitted RF signal **162**.

Assume the gain of amplifier **176** is ~30 dB, and isolation between two output ports of 2-way combiner-splitter **177** is ~30 dB. The feedback signal through combiner port coupling may be 30 dB below the main signal, which, comparing to the interference resulting from the signal ringing, contributes only a small portion of the total interference. The feedback through signal ringing could be more dominant. Assume the nominal return loss of a tap is ~20 dB, with an additional 4 dB loss of cable/combiner, the reflected portion of transmitted signal **162** may be 6 dB above the desired signal on upstream pathway **180** of transceiver **18**. For mathematical simplicity, interference from signal ringing (e.g., reflection of transmitted signal **162** into upstream pathway **180** and reflection of received signal **164** into downstream pathway **172**) may be more dominant than reflections from outside transceiver **18**.

For purposes of explaining mathematically, BB reference signal **174** is referred to in the figure as tx1' or alternatively as rx_r0; RF reference signal **182** comprises tx2' (referring to transmitted signal **162**) and rx0 (comprising a portion of received RF signal **164**) and is referred to, for mathematical convenience, as rx_r; τ corresponds to delay, with τ_i being delay on upstream pathway **180**, and τ_r being delay on downstream pathway **172**. Explanations of the mathematical symbols (e.g., notations) in the figure described herein are presented in the following table:

Symbol	Relationship	Note	Channel
rx0	received signal	received signal on upstream pathway	ideal BB signal, HFC channel
rx_i	$rx_i = tx2'$	received interference on upstream pathway (approximated to be same as transmitted RF signal merely for simplicity of explanation)	2:1 combiner + HFC channel
rx	$rx = rx0 + c1*rx_i$	total received signal on upstream pathway; c1 is scaling factor	
rx_r	$rx_r = tx2' + c2*rx0$	RF reference signal; c2 is scaling factor (reflection of received signal on downstream pathway approximated to be a scaled factor of received signal merely for simplicity of explanation)	hardware channel
rx_r0	$rx_r0 = tx1'$	BB reference signal	no additional channel
tx0	$tx0 = conv(w1, rx) - conv(w0, rx_r)$	received signal on upstream pathway after interference cancellation; conv refers to convolution function; w0 and w1 are convolution coefficients	no additional channel
tx1'		transmitted BB signal on downstream pathway	no additional channel
tx2'	Fcn(tx1')	transmitted RF signal on downstream	nonlinear channel,

Symbol	Relationship	Note	Channel
		pathway; Fcn refers to noise, amplification and DAC functions	noise

AIC module **176** performs numerous iterations according to the AIC algorithm to reduce interference. In some embodiments, the AIC algorithm comprises calculating values of scaling factors c_1 and c_2 , and convolution coefficients w_1 , w_0 , which are used to compute and cancel interferences of the transmitted and received signals. AIC module **176** performs interference calculations using various mathematical functions, including convolution. In a general sense, convolution is a mathematical operation on two functions, producing a third function that is typically viewed as a modified version of one of the original functions. For example, convolution is the integral of the product of the two functions after one is reversed and shifted. Mathematically, convolution of functions $f(t)$ and $g(t)$ can be written as $(f*g)(t)$ to be:

$$(f*g)(t) = \int_0^{\infty} f(t-\tau)g(\tau)d\tau$$

Convolution is applicable because interferences can appear due to time-shifting or time lag between transmitted signals and reflected signals (e.g., signal at time t interfered by reflection of transmitted signal at time $t-\tau$; and so on). In a general sense, convolution in the time domain can be represented by multiplication in the frequency domain. The AIC algorithm performs convolutions on received RF signal **164** and RF reference signal **182**, followed by a cancellation of the convoluted RF reference signal from the convoluted received RF signal. The AIC algorithm uses convolution coefficients w_0 and w_1 on time-shifted samples of received RF signal **164** and RF reference signal **182** that account for time delays in reflection, the time-shifted samples being weighted with scaling factors c_1 and c_2 (e.g., to account for attenuations). The AIC algorithm iteratively calculates convolution coefficients w_0 and w_1 and scaling factors c_1 and c_2 .

Turning to FIG. **21**, FIG. **21** is a simplified block diagram illustrating example details of AIC module **176** according to an embodiment of communication system **10**. AIC module **176** includes a FFT module **190** for separating incoming signals (e.g., RF signals **164** and **182**) into a plurality of subcarriers (e.g., M subcarriers). A plurality of AIC blocks **192** (e.g., $AIC_0, AIC_1, \dots, AIC_{M-1}$) corresponding to the plurality of subcarriers perform AIC iterations on the respective signals. RF reference signal **182** is provided to FFT module **190** after converting to a digital signal (e.g., by ADC **183**); likewise received RF signal **164** is input to FFT module **190** after converting to a digital signal (e.g., by ADC **185**). Because full duplex communication implies a common frequency range for upstream and downstream, BB reference signal **174** and RF reference signal **182** can indicate the common channel impulse response for both upstream and downstream communication. The transformed signals from FFT module **190** may be separated out into individual subcarrier frequencies based on information of the plurality of subcarrier frequencies comprised in digital reference signal **174**. Each AIC block **192** may separately execute the AIC algorithm to reduce interferences.

Turning to FIG. **22**, FIG. **22** is a simplified block diagram illustrating example details of AIC module **176** according to an embodiment of communication system **10**. $R(t)$ is RF

reference signal **182** input into AIC module **176**; $I(t)$ is the interference signal coupled with desired signal **186**; $Z(t)$ is input RF signal **164**, and comprises a combination of interference signal $I(t)$ and desired signal $S(t)$. AIC algorithms may execute assuming interference from signals during a time interval divided into n periods. For example, the interference may comprise reference signal $R(t), R(t-\tau), R(t-2\tau) \dots R(t-(n-1)\tau)$. Each time-shifted sample $R(t-\tau), R(t-2\tau) \dots R(t-(n-1)\tau)$ may be attenuated suitably. The attenuation may be captured as weighting factors c_0, c_1, \dots, c_{N-1} , corresponding to the n periods. For example, estimated interference signal based on the reference signal comprises $c_0R(t)+c_1R(t-\tau)+ \dots +c_{N-1}R(t-(n-1)\tau)$. In an example embodiment, the weighting factors may comprise a combination of scaling factors c_1 and c_2 and convolution coefficients w_0 and w_1 .

The estimated interference signal may be compared with the input signal and a residue, comprising the difference, computed. The residue may be used to update values of weighting factors c_0, c_1, \dots, c_{N-1} suitably. The residue can indicate that further iterations are in order, and values of weighting factors c_0, c_1, \dots, c_{N-1} may be updated and the operations repeated until an acceptable residue is obtained. The AIC algorithm can converge and take full effect within seconds. The channels in cable network **12** being quasi-static (i.e., no mobility), the AIC algorithm can maintain tracking of channel variations caused by various parameters such as temperature variations, environment changes, or device aging.

Note that in some embodiments, AIC module **176** executes the AIC algorithm as described herein separately for each subcarrier frequency. In such embodiments, $R(t), Z(t), I(t)$ and $S(t)$ correspond to the portion of the respective signals (e.g., RF reference signal **182**, RF signal **164**, interference signal, and desired signal **186**) corresponding to the particular subcarrier frequency at which the AIC algorithm is being executed. For example, if AIC algorithm at subcarrier frequency i is being executed, $R_i(t), Z_i(t), I_i(t)$ and $S_i(t)$ correspond to portions of RF reference signal **182**, RF signal **164**, interference signal, and desired signal **186** at subcarrier frequency i .

Turning to FIGS. **23A** and **23B**, FIGS. **23A** and **23B** are simplified block diagrams illustrating an example amplifier **20** according to an embodiment of communication system **10**. Note that amplifier **20** is more complicated than transceiver **18**, but the basic DSP building function blocks are similar. Amplifier **20** includes a ringing suppressor **200** each on downstream pathway **172** and upstream pathway **180**; a downstream amplifier **202**; an upstream amplifier **204**; and a two-way combiner-splitter **206** on each end. The DSP algorithm in ringing suppressor **200** is similar to AIC module **176** of transceiver **18**, with some modifications for echo cancellation. In a general sense, discontinuities (e.g., limited return loss of tap/splitter, etc.) are inevitably present in cable network **12**, and cause signal bouncing, resulting in signal ringing. Signal ringing can be the main source of the interferences between downstream pathway **172** and upstream pathway **180** in full duplex operation.

Signal flows on downstream pathway 172 enter amplifier 20 through two-way combiner-splitter 206 on one end, flows through ringing suppressor 200 on downstream pathway 172, is amplified at downstream amplifier 202, and exits out through two-way combiner-splitter 206 on the other end. Signal flows on upstream pathway 180 enter amplifier 20 through two-way combiner-splitter 206 on one end, flows through ringing suppressor 200 on upstream pathway 180, is amplified at upstream amplifier 204, and exits out through two-way combiner-splitter 206 on the other end. The signal flows on downstream pathway 172 and upstream pathway 180 can be considered to be mirror images of each other; as such, ringing suppressor 200 on downstream pathway 172 can be identical with ringing suppressor 200 on upstream pathway 180.

In some embodiments, two steps of echo cancellations are implemented in ringing suppressor 200. At step 1, the AIC algorithm of transceiver 18 is implemented with a relaxed cancellation specification (e.g., suppressing interferences to a few dB below the desired signal). Some of the interference residue out of this step may loop back to the other pathway of amplifier 20 where it is suppressed in step 2, and some of the interference residue may proceed to transceiver 18 where it is cancelled at AIC module 176 of transceiver 18. In step 2, echoes from the same pathway may be cancelled. The echo cancellation algorithm at step 2 comprises a modified AIC algorithm with the reference signal being the output signal of the previous step on the same pathway. To enable the echo cancellation, a delay may be added on each pathway to ensure that the reflections are distinct in time from the main signal so they can be suppressed with the echo cancellation algorithm.

To explain further, ringing suppressor 200 includes two echo cancellation modules 208 and 210. Input to echo cancellation module 208 includes BB reference signal 212 and RF reference signal 214 from the other pathway (e.g., for ringing suppressor 200 on upstream pathway 180, BB reference signal 212 and RF reference signal 214 are from downstream pathway 172; and vice versa). Unlike transceiver 18, amplifier 20 requires echo cancellation on each pathway from its own signal. To this end, echo cancellation module 210 performs echo cancellation on signals output from echo cancellation module 208. The reference signal to echo cancellation module 210 may comprise a time-shifted output signal from echo cancellation module 208. In an example embodiment, the time shifting may be by two time periods (2τ). The digital portion of the output from echo cancellation module 210 may be fed as BB reference signal 212 to ringing suppressor 200 on the other pathway.

Turning to FIG. 23B, FIG. 23B shows example mathematical details of amplifier 20 according to an embodiment of communication system 10. Amplifier 20 can be considered to comprise mirror images 216 and 218 around imaginary separator 219. Each portion 216 and 218 comprises an amplifier, a signal flowing through downstream pathway 172, another signal flowing through upstream pathway 180, and two echo cancellation modules 208 and 210. For the sake of simplicity, echo cancellation module 208 is referred to as equalizer 1 (EQ1), and echo cancellation module 210 is referred to as equalizer 2 (EQ2). EQ1 computes convolution coefficients w_0 , and w_1 ; EQ2 computes convolution coefficient w_2 . The various symbols and notations in the figure are explained in the following table:

Signals	Relationship	Note	Channel
rx0	received signal	received signal on upstream pathway	ideal BB signal, HFC channel
rx_i	$rx_i = tx2'$	received interferences on upstream pathway	2:1 combiner + HFC channel
rx	$rx = rx0 + c1*rx_i$	total received signal on upstream pathway; $c1$ is a scaling factor	
rx_r	$rx_r = tx2' + c2*rx0'$	received RF reference signal on upstream pathway; $c2$ is a scaling factor	hardware channel
rx_r0	$rx_r0 = tx1'$	received BB reference signal on upstream pathway	no additional channel
tx0	$tx0 = \text{conv}(w1, rx(t - \tau_i)) - \text{conv}(w0, rx_r(t - \tau_r))$	transmitted signal after first interference cancellation on upstream pathway; $1 \leq \tau \leq \min(\tau_i, \tau_r)$, τ corresponding to delay, with τ_i being the delay on the upstream pathway, and τ_r being the delay on the downstream pathway	no additional channel
tx1	$tx1 = tx0 - \text{conv}(w2, tx0(t - 2\tau_i))$	transmitted signal after second interference cancellation on upstream pathway	no additional channel
tx2	$Fcn(tx1)$	transmitted RF signal on upstream pathway; Fcn refers to noise, amplification and DAC functions	nonlinear channel, noise
rx0'	received signal	received signal on downstream pathway	ideal BB signal, HFC channel
rx_i'	$rx_i' = tx2$	received interferences on downstream pathway	2:1 combiner + HFC channel
rx'	$rx' = rx0' + c1'*rx_i'$	total received signal on downstream pathway; $c1'$ is a scaling factor	hardware channel
rx_r'	$rx_r' = tx2 + c2'*rx0$	received RF reference signal on downstream pathway; $c2'$ is a scaling factor	hardware channel
rx_r0'	$rx_r0' = tx1$	received BB reference signal on downstream pathway	no additional channel
tx0'	$tx0' = \text{conv}(w1', rx'(t - \tau_i)) - \text{conv}(w0', rx_r'(t - \tau_r))$	transmitted signal after first interference cancellation on downstream pathway	no additional channel

-continued

Signals	Relationship	Note	Channel
tx1'	$tx1' = tx0' - \text{conv}(w2', tx0'(t - 2\tau_i))$	transmitted signal after second interference cancellation on downstream pathway	no additional channel
tx2'	Fcn(tx1')	transmitted RF signal on downstream pathway; Fcn refers to noise, amplification and DAC functions	nonlinear channel, noise

Each pathway generates 4 signals (e.g., rx, tx0, tx1, and tx2 on upstream pathway and rx', t0', tx1' and tx2' on downstream pathway), and receives three signals, rx_i, rx_r, rx_r0, from the other pathway. c1, c2, c1', and c2' are constants (scaling factors)

Turning to FIG. 24, FIG. 24 is a simplified diagram showing an example AIC algorithm 220 for computing convolution coefficients according to an example embodiment. Equalizer 208 (EQ1) of amplifier 20, and AIC module 176 of transceiver 18 execute algorithm 220 and determines values of convolution coefficients w0 and w1. AIC algorithm 220 presented herein is in MATLAB language. However, it will be appreciated by persons with skill in the art that any suitable programming language may be used to implement AIC algorithm 220 within the broad scope of the embodiments.

Turning to FIG. 25, FIG. 25 is a simplified diagram showing an example echo cancellation algorithm 222 for computing convolution coefficients according to an example embodiment. Equalizer 210 (EQ2 or EQ2') of amplifier 20 executes echo cancellation algorithm 222 and determines values of convolution coefficient w2. Echo cancellation algorithm 222 presented herein is in MATLAB language. However, it will be appreciated by persons with skill in the art that any suitable programming language may be used to implement echo cancellation algorithm 222 within the broad scope of the embodiments.

Turning to FIG. 26, FIG. 26 is a simplified block diagram illustrating example details of a hardware implementation of amplifier 20 according to an embodiment of communication system 10. Amplifier 20 may include downstream amplifier 202, upstream amplifier 204, a downstream receive module 224 and an upstream receive module 226. Each receive module 224 may be similar to receiver portion 168 of transceiver 18. A DSP 228 may execute AIC algorithm 220 and echo cancellation algorithm 222. In some embodiments, ringing suppressor 200 may be implemented in DSP 228. A clock 230 may facilitate timing operations of DSP 228. Various modules, such as downstream amplifier 202, upstream amplifier 204, downstream receive module 224 and upstream receive module 226 may be RF shielded from each other appropriately.

Turning to FIG. 27, FIG. 27 is a simplified flow diagram illustrating example operations 250 associated with interference cancellation according to an embodiment of communication system 10. At 252, a BB reference signal (e.g., tx1') is generated on a first pathway (e.g., downstream pathway 172 or upstream pathway 180) of a network element. As used herein, the term "network element" encompasses a transceiver (e.g., transceiver 18), an amplifier (e.g., amplifier 20), or other network component of cable network 12 supports full duplex communication, and through which signals flow in an upstream direction and downstream direction in overlapping frequency ranges. If the network element is a transceiver, the BB reference signal tx1' may be generated at transceiver 14; if the network element is an amplifier, the BB reference signal may be provided from a second pathway (e.g., if the first pathway is downstream pathway 172, the second pathway is upstream pathway 180, and vice versa).

At 254, the BB reference signal tx1' is converted to a first RF signal tx2'. At 256, the BB reference signal tx1' is provided to a signal processor (e.g., DSP 170, DSP 228) as BB reference signal rx_r0. At 258, the first RF signal tx2' is transmitted on the first pathway. At 260, the first RF signal tx2' is reflected into the second pathway. At 262, the reflection (e.g., rx_i) interferes with signals (e.g., rx0) on the second pathway generating a second RF signal rx ($rx=rx0+c1*rx_i$) on the second pathway. At 264, the second RF signal rx is provided as input to the signal processor (e.g., after suitably amplifying and converting to digital domain). At 266, the second RF signal is reflected into the first pathway. At 268, the reflection interferes with first RF signal tx2' generating RF reference signal rx_r on the first pathway ($rx_r=tx2'+c2*rx0$). At 270, the RF reference signal rx_r is provided to the signal processor (e.g., after suitably amplifying and converting to digital domain). At 272, the signal processor reduces interferences in the second RF signal rx from reflections of the first RF signal tx2' based on the BB reference signal rx_r0 and RF reference signal rx_r to generate output tx0. At 274, if the network element is an amplifier (e.g., as opposed to a transceiver), the signal processor further reduces interferences in the second RF signal rx from echoes of itself to generate output tx1; in effect a time-shifted sample of tx0 is fed as the reference signal for echo cancellation purposes. In some embodiments, the time-shifting is equal to two time periods (e.g., 2τ) at 276. Operations 252 to 276 described so far comprise interference cancellations on the second pathway due to reflections from the first pathway.

At 278, the first branch and the second branch are transposed figuratively. In other words, the output tx1 comprises the BB signal on the second pathway, which is fed into the AIC module of the first pathway as the BB reference signal for interference cancellation on the first pathway. Operations 252 to 276 are repeated for interference cancellations on the first pathway due to reflections from the second pathway. Note that the transceiver does not have parallel mirror-image pathways and is less complex than the amplifier in regards to interference cancellation operations.

Turning to FIG. 28, FIG. 28 is a simplified flow diagram illustrating example operations 280 that may be associated with AIC operations according to an example embodiment of communication system 10. At 282, the input signal (rx, rx') and the reference signal (e.g., rx_r, rx_r') provided to the signal processor (e.g., DSP 170, DSP 228) may be separated into subcarrier frequencies in the digital domain (e.g., after FFT, and comparison with BB reference signal rx_r0, rx_r0'). The input signal refers to the signal to be processed to remove interferences. At 284, the input signal is subjected to a convolution function. For example, the convolution function may result in a signal comprising weighted time-shifted samples of the input signal. At 286, the reference signal is subjected to another convolution function. For example, the another convolution function may result in

another signal comprising weighted time-shifted samples of the reference signal. At **290**, the convoluted reference signal is cancelled (e.g., subtracted) from the convoluted input signal. Operations **284-290** may be repeated at each subcarrier frequency.

Turning to FIG. **29**, FIG. **29** is a simplified flow diagram illustrating example operations **300** that may be associated with AIC operations according to an example embodiment of communication system **10**. At **302**, time-shifted samples of RF reference signal ($R(t)$) is determined (e.g., at time t , $t-\tau$, $t-2\tau$, . . . $t-(n-1)\tau$). At **304**, weighting factors (e.g., C_1 , C_2 , . . . C_{N-1}) is estimated. At **306**, an interference signal is estimated as a weighted sum of the time-shifted samples (e.g., $\sum_0^{n-1} R(t-i\tau)$). At **308**, a residue is calculated between the estimated interference signal and the input signal ($Z(t)$). At **310**, a determination is made whether the calculated residue is less than a predetermined threshold. If not, at **312**, the weighting factors are updated based on the calculated residue and the operations loop back to **306**, and continue thereafter in successive iterations. If the residue is less than the predetermined threshold, at **314**, the output signal ($S(t)$) is determined to be the input signal without interferences (e.g., $S(t)=Z(t)-I(t)$).

Turning to FIGS. **30A**, **30B**, and **30C**, FIGS. **30A**, **30B**, and **30C** show simulation results with various amplifier types. FIG. **30A** shows received signal constellations with amplifier **20** that does not include echo cancellation module **210** (e.g., without EQ2). At receiver input, the interference level is 14 dBm, and desired signal level is 0 dBm. The SNR of desired signal (thermal noise, without impairments) is 50 dB. FIG. **30B** shows signal quality of signal tx2, and FIG. **30C** shows signal quality of signal tx2'.

Note that in this Specification, references to various features (e.g., elements, structures, modules, components, steps, operations, characteristics, etc.) included in "one embodiment", "example embodiment", "an embodiment", "another embodiment", "some embodiments", "various embodiments", "other embodiments", "alternative embodiment", and the like are intended to mean that any such features are included in one or more embodiments of the present disclosure, but may or may not necessarily be combined in the same embodiments. Furthermore, the words "optimize," "optimization," and related terms are terms of art that refer to improvements in speed and/or efficiency of a specified outcome and do not purport to indicate that a process for achieving the specified outcome has achieved, or is capable of achieving, an "optimal" or perfectly speedy/perfectly efficient state.

In example implementations, at least some portions of the activities outlined herein may be implemented in software in, for example, CMTS **14**, MAC scheduler **26**, amplifier **20**, and transceiver **18**. In some embodiments, one or more of these features may be implemented in hardware, provided external to these elements, or consolidated in any appropriate manner to achieve the intended functionality. The various components may include software (or reciprocating software) that can coordinate in order to achieve the operations as outlined herein. In still other embodiments, these elements may include any suitable algorithms, hardware, software, components, modules, interfaces, or objects that facilitate the operations thereof.

Furthermore, CMTS **14**, MAC scheduler **26**, amplifier **20**, and transceiver **18** described and shown herein (and/or their associated structures) may also include suitable interfaces for receiving, transmitting, and/or otherwise communicating data or information in a network environment. Additionally, some of the processors and memory elements associated

with the various nodes may be removed, or otherwise consolidated such that a single processor and a single memory element are responsible for certain activities. In a general sense, the arrangements depicted in the FIGURES may be more logical in their representations, whereas a physical architecture may include various permutations, combinations, and/or hybrids of these elements. It is imperative to note that countless possible design configurations can be used to achieve the operational objectives outlined here. Accordingly, the associated infrastructure has a myriad of substitute arrangements, design choices, device possibilities, hardware configurations, software implementations, equipment options, etc.

In some of example embodiments, one or more memory elements (e.g., memory element **28**) can store data used for the operations described herein. This includes the memory element being able to store instructions (e.g., software, logic, code, etc.) in non-transitory media, such that the instructions are executed to carry out the activities described in this Specification. A processor can execute any type of instructions associated with the data to achieve the operations detailed herein in this Specification. In one example, processors (e.g., processor **27**, DSP **170**, DSP **228**) could transform an element or an article (e.g., data) from one state or thing to another state or thing. In another example, the activities outlined herein may be implemented with fixed logic or programmable logic (e.g., software/computer instructions executed by a processor) and the elements identified herein could be some type of a programmable processor, programmable digital logic (e.g., a field programmable gate array (FPGA), an erasable programmable read only memory (EPROM), an electrically erasable programmable read only memory (EEPROM)), an ASIC that includes digital logic, software, code, electronic instructions, flash memory, optical disks, CD-ROMs, DVD ROMs, magnetic or optical cards, other types of machine-readable mediums suitable for storing electronic instructions, or any suitable combination thereof.

These devices may further keep information in any suitable type of non-transitory storage medium (e.g., random access memory (RAM), read only memory (ROM), field programmable gate array (FPGA), erasable programmable read only memory (EPROM), electrically erasable programmable ROM (EEPROM), etc.), software, hardware, or in any other suitable component, device, element, or object where appropriate and based on particular needs. The information being tracked, sent, received, or stored in communication system **10** could be provided in any database, register, table, cache, queue, control list, or storage structure, based on particular needs and implementations, all of which could be referenced in any suitable timeframe. Any of the memory items discussed herein should be construed as being encompassed within the broad term 'memory element.' Similarly, any of the potential processing elements, modules, and machines described in this Specification should be construed as being encompassed within the broad term 'processor.'

It is also important to note that the operations and steps described with reference to the preceding FIGURES illustrate only some of the possible scenarios that may be executed by, or within, the system. Some of these operations may be deleted or removed where appropriate, or these steps may be modified or changed considerably without departing from the scope of the discussed concepts. In addition, the timing of these operations may be altered considerably and still achieve the results taught in this disclosure. The preceding operational flows have been offered for purposes of

example and discussion. Substantial flexibility is provided by the system in that any suitable arrangements, chronologies, configurations, and timing mechanisms may be provided without departing from the teachings of the discussed concepts.

Although the present disclosure has been described in detail with reference to particular arrangements and configurations, these example configurations and arrangements may be changed significantly without departing from the scope of the present disclosure. For example, although the present disclosure has been described with reference to particular communication exchanges involving certain network access and protocols, communication system **10** may be applicable to other exchanges or routing protocols. Moreover, although communication system **10** has been illustrated with reference to particular elements and operations that facilitate the communication process, these elements, and operations may be replaced by any suitable architecture or process that achieves the intended functionality of communication system **10**.

Numerous other changes, substitutions, variations, alterations, and modifications may be ascertained to one skilled in the art and it is intended that the present disclosure encompass all such changes, substitutions, variations, alterations, and modifications as falling within the scope of the appended claims. In order to assist the United States Patent and Trademark Office (USPTO) and, additionally, any readers of any patent issued on this application in interpreting the claims appended hereto, Applicant wishes to note that the Applicant: (a) does not intend any of the appended claims to invoke paragraph six (6) of 35 U.S.C. section 112 as it exists on the date of the filing hereof unless the words “means for” or “step for” are specifically used in the particular claims; and (b) does not intend, by any statement in the specification, to limit this disclosure in any way that is not otherwise reflected in the appended claims.

What is claimed is:

1. A method comprising:
 - generating a global interfered list for a plurality of cable modems in a cable network, the global interfered list comprising an aggregation of a plurality of interfered lists corresponding to a plurality of frequency ranges, each interfered list comprising cable modems whose downstream receptions are interfered by upstream transmissions of other cable modems in the corresponding frequency range;
 - generating a global interfering list for the plurality of cable modems, the global interfering list comprising an aggregation of a plurality of interfering lists corresponding to the plurality of frequency ranges, each interfering list comprising cable modems whose upstream transmissions interfere with downstream receptions of other cable modems in the corresponding frequency range;
 - assigning respective downstream reception frequency ranges and upstream transmission frequency ranges for the plurality of cable modems based on the global interfered list and the global interfering list; and
 - transmitting to the cable modems corresponding assignment information comprising the respective assigned downstream reception frequency ranges and upstream transmission frequency ranges.
2. The method of claim **1**, wherein generating the global interfered list comprises:
 - generating, for a particular cable modem in the cable network, a respective interfered list associated with a particular one of the plurality of frequency ranges, the

- respective interfered list comprising a first list of cable modems whose downstream reception in the frequency range is interfered by upstream transmissions of the particular cable modem in the frequency range;
 - repeating generating the interfered list for other cable modems in the plurality of cable modems and for other frequency ranges in the plurality of frequency ranges; and
 - aggregating the generated interfered lists into the global interfered list.
3. The method of claim **2**, wherein generating the respective interfered list for the particular cable modem comprises:
 - during a maintenance window, scheduling the particular cable modem to transmit a ranging signal within the particular one of the plurality of frequency ranges;
 - receiving reports indicative of interferences on respective downstream reception in the particular one of the plurality of frequency ranges from other cable modems in the cable network;
 - identifying cable modems that are interfered by the transmitting cable modem based on the reports; and
 - adding the identified cable modems to the first list.
 4. The method of claim **2**, wherein the particular cable modem is grouped with the first list of cable modems into an interference group for the frequency range.
 5. The method of claim **2**, wherein the particular cable modem is grouped into a plurality of interference groups corresponding to the plurality of frequency ranges, wherein downstream receptions of cable modems in each interference group for the corresponding frequency range are interfered by upstream transmissions of the cable modem in the corresponding frequency range.
 6. The method of claim **1**, wherein generating the global interfering list comprises:
 - generating, for a particular cable modem in the cable network, a respective interfering list associated with a particular one of the plurality of frequency ranges, the respective interfering list comprising a second list of cable modems whose upstream transmissions in the frequency range interfere with downstream reception of the particular cable modem in the frequency range;
 - repeating generating the interfering list for other cable modems in the plurality of cable modems and for other frequency ranges in the plurality of frequency ranges; and
 - aggregating the generated interfering lists into the global interfering list.
 7. The method of claim **6**, wherein generating the respective interfering list for the particular cable modem comprises deriving the second list of cable modems from the global interfered list.
 8. The method of claim **1**, wherein assigning respective downstream reception frequency ranges and upstream transmission frequency ranges comprises grouping cable modems into groups, each group being isolated on frequency basis from other groups, wherein cable modems in each group are assigned a common downstream reception frequency range and a common upstream transmission frequency range.
 9. The method of claim **1**, wherein the cable modems are grouped into interference groups with other cable modems connected to a commonly coupled amplifier in the cable network.
 10. The method of claim **9**, wherein the interference group is further divided into a plurality of sub-groups with relative

isolation among the sub-groups, wherein each sub-group comprises cable modems attached to a corresponding common tap.

11. The method of claim **9**, wherein cable modems in the interference group transmit upstream at a first frequency and receive downstream at a different frequency within the frequency range.

12. Non-transitory tangible computer-readable media that includes instructions for execution, which when executed by a processor, is operable to perform operations comprising: generating a global interfered list for a plurality of cable modems in a cable network, the global interfered list comprising an aggregation of a plurality of interfered lists corresponding to a plurality of frequency ranges, each interfered list comprising cable modems whose downstream receptions are interfered by upstream transmissions of other cable modems in the corresponding frequency range;

generating a global interfering list for the plurality of cable modems, the global interfering list comprising an aggregation of a plurality of interfering lists corresponding to the plurality of frequency ranges, each interfering list comprising cable modems whose upstream transmissions interfere with downstream receptions of other cable modems in the corresponding frequency range;

assigning respective downstream reception frequency ranges and upstream transmission frequency ranges for the plurality of cable modems based on the global interfered list and the global interfering list; and

transmitting to the cable modems corresponding assignment information comprising the respective assigned downstream reception frequency ranges and upstream transmission frequency ranges.

13. The media of claim **12**, wherein generating the global interfered list comprises:

generating, for a particular cable modem in the cable network, a respective interfered list associated with a particular one of the plurality of frequency ranges, the respective interfered list comprising a first list of cable modems whose downstream reception in the frequency range is interfered by upstream transmissions of the particular cable modem in the frequency range;

repeating generating the interfered list for other cable modems in the plurality of cable modems and for other frequency ranges in the plurality of frequency ranges; and

aggregating the generated interfered lists into the global interfered list.

14. The media of claim **13**, wherein generating the respective interfered list for the particular cable modem comprises: during a maintenance window, scheduling the particular cable modem to transmit a ranging signal within the particular one of the plurality of frequency ranges;

receiving reports indicative of interferences on respective downstream reception in the particular one of the plurality of frequency ranges from other cable modems in the cable network;

identifying cable modems that are interfered by the transmitting cable modem based on the reports; and adding the identified cable modems to the first list.

15. The media of claim **12**, wherein generating the global interfering list comprises:

generating, for a particular cable modem in the cable network, a respective interfering list associated with a particular one of the plurality of frequency ranges, the respective interfering list comprising a second list of

cable modems whose upstream transmissions in the frequency range interfere with downstream reception of the particular cable modem in the frequency range; repeating generating the interfering list for other cable modems in the plurality of cable modems and for other frequency ranges in the plurality of frequency ranges; and

aggregating the generated interfering lists into the global interfering list.

16. The media of claim **12**, wherein assigning respective downstream reception frequency ranges and upstream transmission frequency ranges comprises grouping cable modems into groups, each group being isolated on frequency basis from other groups, wherein cable modems in each group are assigned a common downstream reception frequency range and a common upstream transmission frequency range.

17. An apparatus, comprising:

a memory for storing data; and

a processor operable to execute instructions associated with the data, wherein the processor and the memory cooperate, such that the apparatus is configured for:

generating a global interfered list for a plurality of cable modems in a cable network, the global interfered list comprising an aggregation of a plurality of interfered lists corresponding to a plurality of frequency ranges, each interfered list comprising cable modems whose downstream receptions are interfered by upstream transmissions of other cable modems in the corresponding frequency range;

generating a global interfering list for the plurality of cable modems, the global interfering list comprising an aggregation of a plurality of interfering lists corresponding to the plurality of frequency ranges, each interfering list comprising cable modems whose upstream transmissions interfere with downstream receptions of other cable modems in the corresponding frequency range;

assigning respective downstream reception frequency ranges and upstream transmission frequency ranges for the plurality of cable modems based on the global interfered list and the global interfering list; and

transmitting to the cable modems corresponding assignment information comprising the respective assigned downstream reception frequency ranges and upstream transmission frequency ranges.

18. The apparatus of claim **17**, wherein assigning respective downstream reception frequency ranges and upstream transmission frequency ranges comprises grouping cable modems into groups, each group being isolated on frequency basis from other groups, wherein cable modems in each group are assigned a common downstream reception frequency range and a common upstream transmission frequency range.

19. The apparatus of claim **17**, wherein generating the global interfered list comprises:

generating, for a particular cable modem in the cable network, a respective interfered list associated with a particular one of the plurality of frequency ranges, the respective interfered list comprising a first list of cable modems whose downstream reception in the frequency range is interfered by upstream transmissions of the particular cable modem in the frequency range;

repeating generating the interfered list for other cable modems in the plurality of cable modems and for other frequency ranges in the plurality of frequency ranges; and

aggregating the generated interfered lists into the global interfered list.

20. The apparatus of claim **19**, wherein generating the respective interfered list for the particular cable modem comprises:

5 during a maintenance window, scheduling the particular cable modem to transmit a ranging signal within the particular one of the plurality of frequency ranges;
receiving reports indicative of interferences on respective downstream reception in the particular one of the 10 plurality of frequency ranges from other cable modems in the cable network;
identifying cable modems that are interfered by the transmitting cable modem based on the reports; and
15 adding the identified cable modems to the first list.

* * * * *