



(12) **United States Patent Court**

(10) **Patent No.: US 9,848,002 B2**  
(45) **Date of Patent: \*Dec. 19, 2017**

(54) **ALLOWING FIRST MODULE OF COMPUTER CODE TO MAKE USE OF SERVICE PROVIDED BY SECOND MODULE WHILE ENSURING SECURITY OF SYSTEM**

(71) Applicant: **Guest Tek Interactive Entertainment Ltd., Calgary (CA)**

(72) Inventor: **Gary R. Court, Calgary (CA)**

(73) Assignee: **Guest Tek Interactive Entertainment Ltd., Calgary (CA)**

(\* ) Notice: Subject to any disclaimer, the term of this patent is extended or adjusted under 35 U.S.C. 154(b) by 0 days.

This patent is subject to a terminal disclaimer.

(21) Appl. No.: **15/290,791**

(22) Filed: **Oct. 11, 2016**

(65) **Prior Publication Data**

US 2017/0034180 A1 Feb. 2, 2017

**Related U.S. Application Data**

(63) Continuation of application No. 14/702,729, filed on May 3, 2015, now Pat. No. 9,489,539, which is a (Continued)

(51) **Int. Cl.**  
*H04L 29/06* (2006.01)  
*G06F 9/46* (2006.01)  
(Continued)

(52) **U.S. Cl.**  
CPC ..... *H04L 63/102* (2013.01); *G06F 9/468* (2013.01); *G06F 21/53* (2013.01); *G06F 21/60* (2013.01);  
(Continued)

(58) **Field of Classification Search**  
CPC ..... H04L 63/102  
See application file for complete search history.

(56) **References Cited**

**U.S. PATENT DOCUMENTS**

6,138,235 A \* 10/2000 Lipkin ..... G06F 9/468 380/255

6,775,668 B1 8/2004 Goel  
(Continued)

**OTHER PUBLICATIONS**

Google-Caja, "A source-to-source translator for securing Javascript-based web content", <http://code.google.com/p/google-caja/>, downloaded Nov. 15, 2010. (5 pages).

(Continued)

*Primary Examiner* — Shawnochoy Rahman

(74) *Attorney, Agent, or Firm* — ATMAC Patent Services Ltd.; Andrew T. MacMillan

(57) **ABSTRACT**

A system for integrating modules of computer code may include a sandbox validator for receiving a first module and verifying that the first module complies with one or more sandbox constraints. A computing device may execute the first module within a runtime environment. A module integrator may operate within the runtime environment for receiving a request from the first module to access a service provided by a second module and only allowing the first module to access the service when the first module is authorized to access the service according to a service authorization table. The sandbox validator may ensure the first module correctly identifies itself when requesting a service provide by another module and that the first module includes runtime policing functions for non-deterministic operations. A service authorizer may generate an authorization policy for the first module, which is sent to the computing device along with the first module.

**20 Claims, 10 Drawing Sheets**

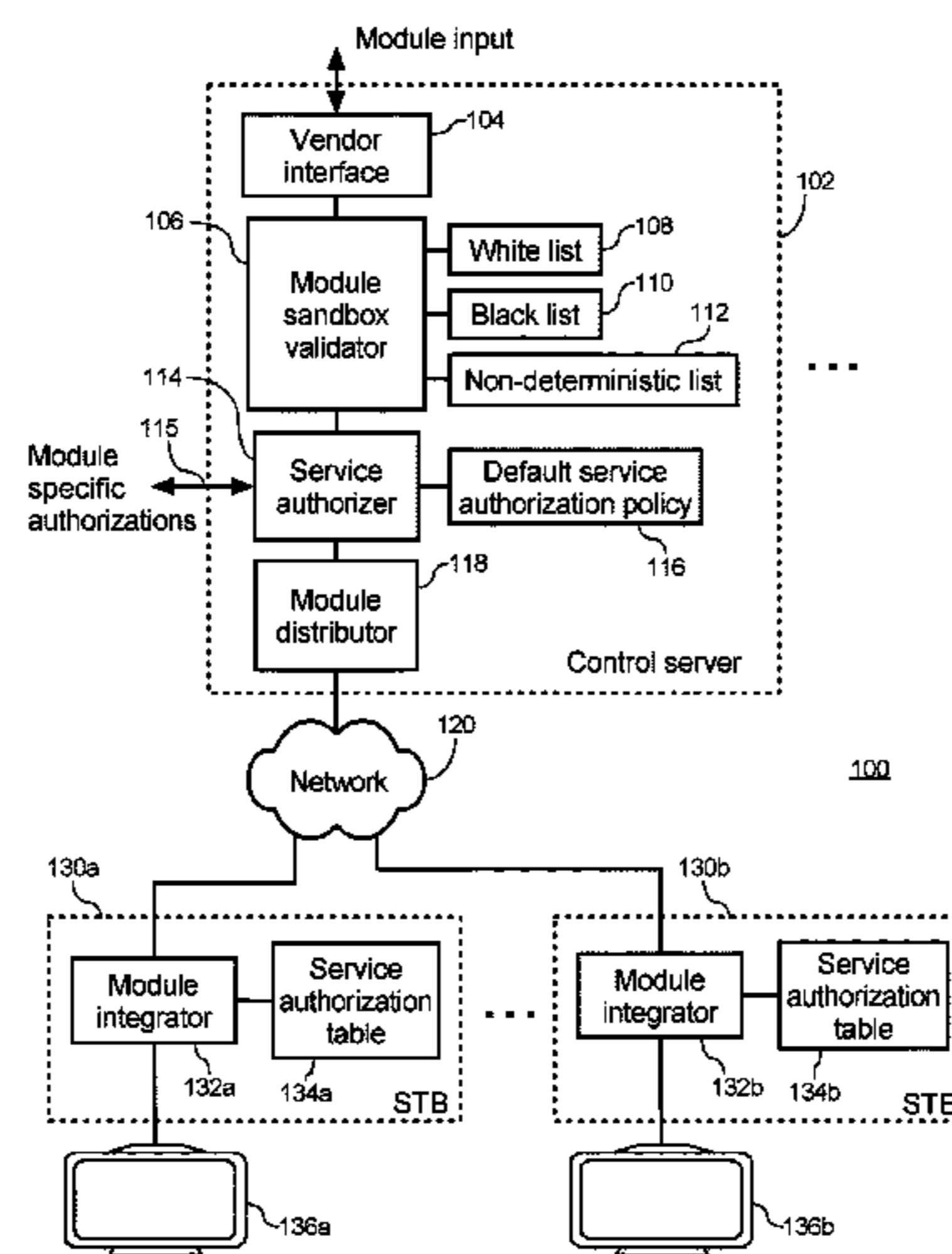

**Related U.S. Application Data**

continuation of application No. 14/063,172, filed on Oct. 25, 2013, now Pat. No. 9,027,150, which is a continuation of application No. 13/108,167, filed on May 16, 2011, now Pat. No. 8,689,344.

(51) **Int. Cl.**

**G06F 21/53** (2013.01)  
**G06F 21/62** (2013.01)  
**G06F 21/60** (2013.01)

(52) **U.S. Cl.**

CPC ..... **G06F 21/629** (2013.01); **G06F 21/6218** (2013.01); **H04L 63/20** (2013.01); **G06F 2221/033** (2013.01); **G06F 2221/2141** (2013.01); **G06F 2221/2149** (2013.01)

(56) **References Cited**

U.S. PATENT DOCUMENTS

6,873,988	B2	3/2005	Herrmann et al.	
7,093,122	B1 *	8/2006	Susser .....	G06F 9/468 713/153
7,650,627	B1	1/2010	Stancheva et al.	
7,836,303	B2	11/2010	Levy et al.	
7,926,086	B1 *	4/2011	Violleau .....	G06F 21/629 713/161
8,011,006	B2	8/2011	Suzuki et al.	
8,136,149	B2	3/2012	Freund	
8,438,640	B1	5/2013	Vaish et al.	

8,689,344	B2	4/2014	Court	
8,806,646	B1	8/2014	Daswani et al.	
9,027,150	B2	5/2015	Court	
9,189,375	B1	11/2015	Bastien et al.	
9,262,628	B2 *	2/2016	Wolfe .....	G06F 11/302
9,489,539	B2	11/2016	Court	
2002/0099944	A1 *	7/2002	Bowlin .....	G06F 21/6218 713/185
2004/0107360	A1	6/2004	Herrmann et al.	
2008/0134310	A1	6/2008	Borde et al.	
2010/0105332	A1	4/2010	McHenry et al.	
2011/0202902	A1	8/2011	Whelan	
2012/0036220	A1	2/2012	Dare et al.	
2012/0204250	A1	8/2012	Anderson et al.	
2014/0344334	A1	11/2014	Trachtenberg et al.	
2015/0007142	A1 *	1/2015	Biffle .....	G06F 21/53 717/126
2015/0235044	A1	8/2015	Cohen et al.	

OTHER PUBLICATIONS

Adsafe, "Making JavaScript Safe for Advertising", <http://www.adsafe.org/>, downloaded Nov. 15, 2010. (4 pages).  
Wikipedia, "Capability-based security", [http://en.wikipedia.org/wiki/Capability-based\\_security](http://en.wikipedia.org/wiki/Capability-based_security), downloaded Nov. 15, 2010. (5 pages).  
Wikipedia, "Object-capability model", [http://en.wikipedia.org/wiki/Object-capability\\_model](http://en.wikipedia.org/wiki/Object-capability_model), downloaded Nov. 15, 2010. (4 pages).  
Corradi, Antonio, et al. "A flexible access control service for Java mobile code." Computer Security Applications, 2000. ACSAC'00. 16th Annual Conference. IEEE, 2000.

\* cited by examiner

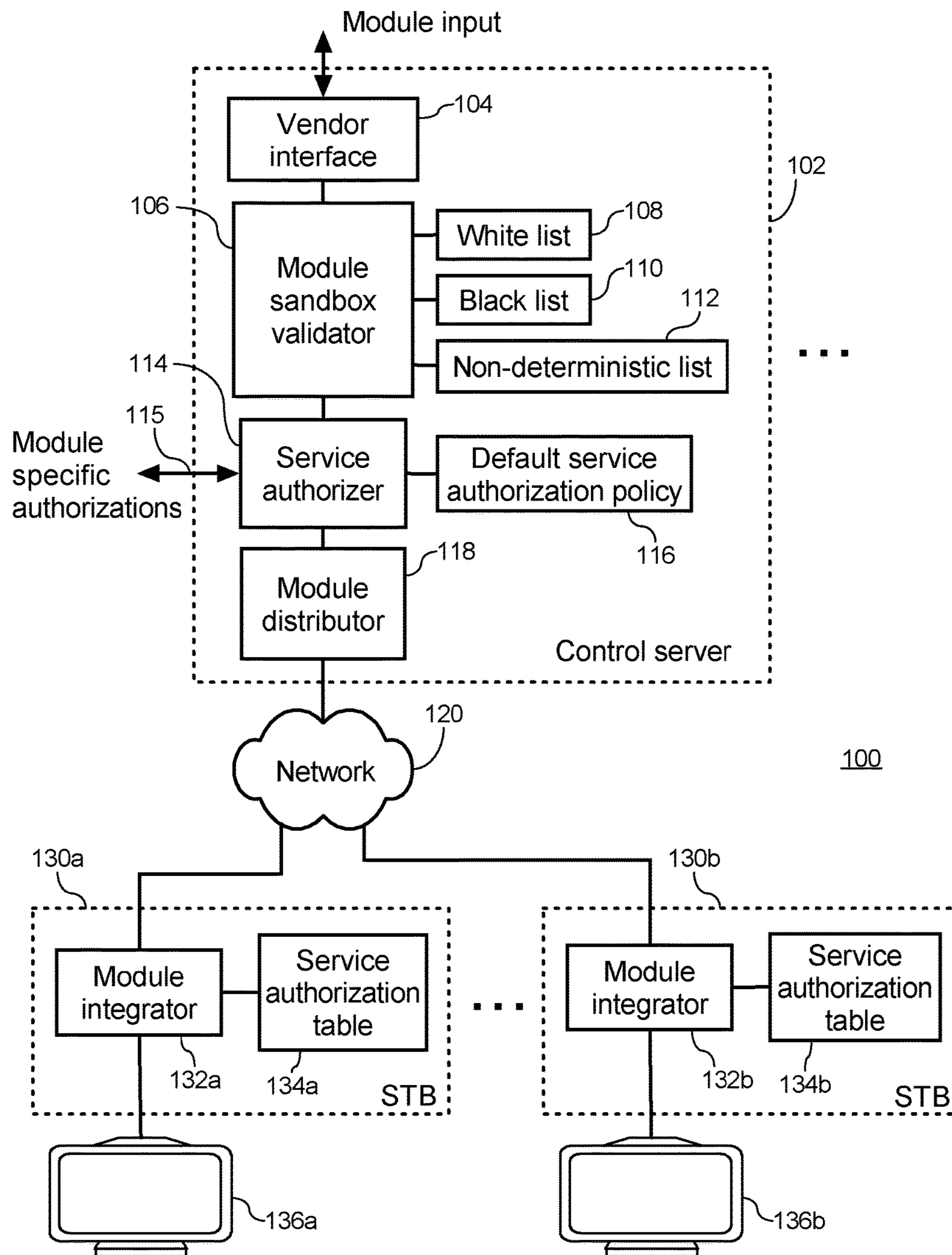

FIG. 1

108

<b>White list</b>	
1	Read / execute-only access to global variables of any of the following types: Math Array Boolean Number String RegExp Date
2	[ ] subscript operators when the subscript is a positive numeric literal or string literal

FIG. 2

110

<b>Black list</b>	
1	Access to global variables
2	The <code>eval</code> function and <code>with</code> statement
3	The use of any of the following names as properties: arguments callee caller constructor eval prototype stack unwatch valueOf watch
4	Property names that start or end with <code>_</code>
5	<code>[]</code> subscript operators

FIG. 3

112

<b>Non-deterministic list</b>	
<p><b>Non-deterministic language features</b></p> <p style="text-align: center; padding: 10px 0;">this</p> <p style="text-align: center; padding: 10px 0;">arguments</p> <p style="text-align: center; padding: 10px 0;"><b>Loops:</b> for while</p>	<p style="text-align: center;"><b>Ensure wrapped with policing function</b></p> <p style="text-align: center; padding: 10px 0;">check(this)</p> <p style="text-align: center; padding: 10px 0;">toArray(arguments)</p> <p style="text-align: center; padding: 10px 0;">loopTimer({loop code})</p>

FIG. 4

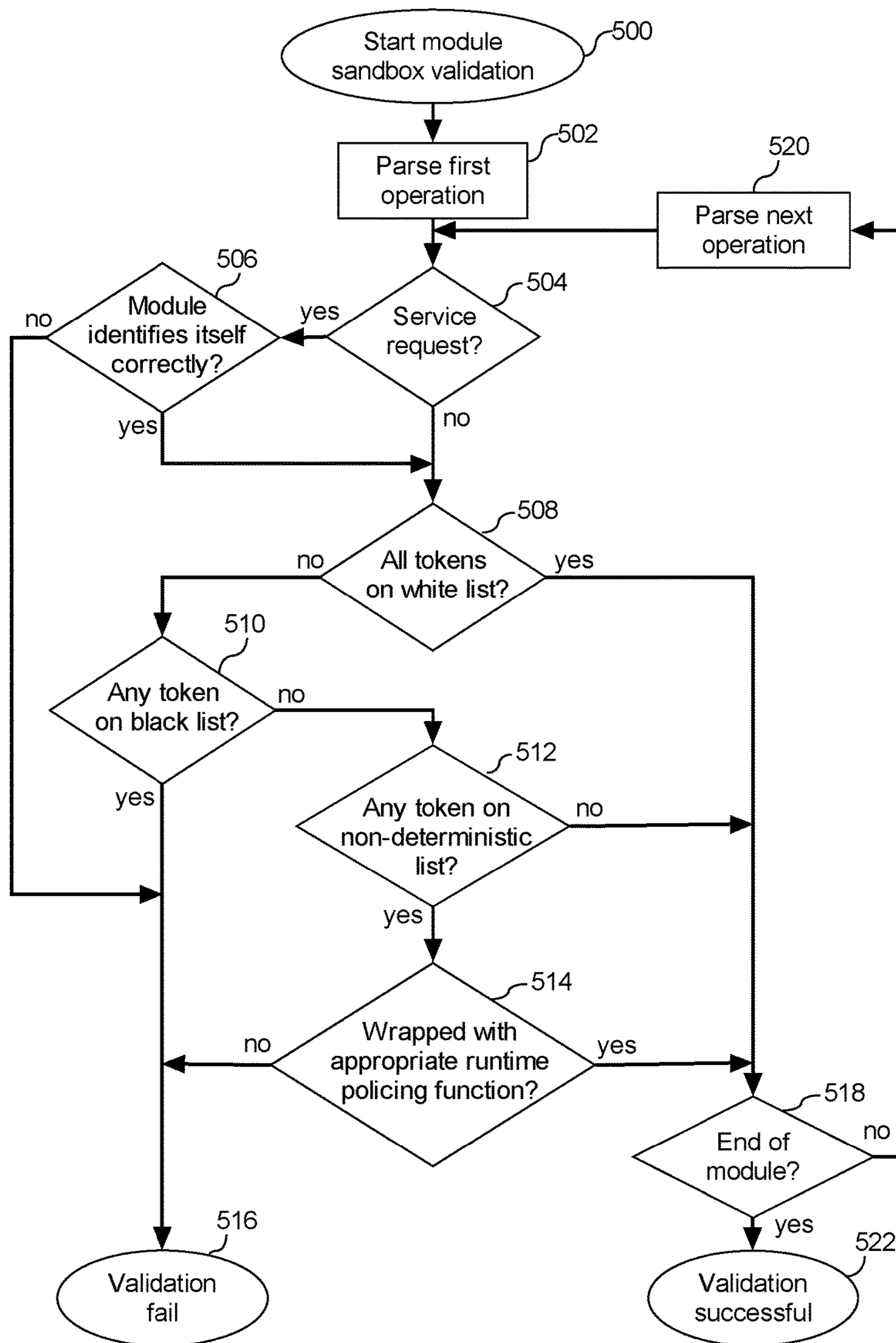

FIG. 5

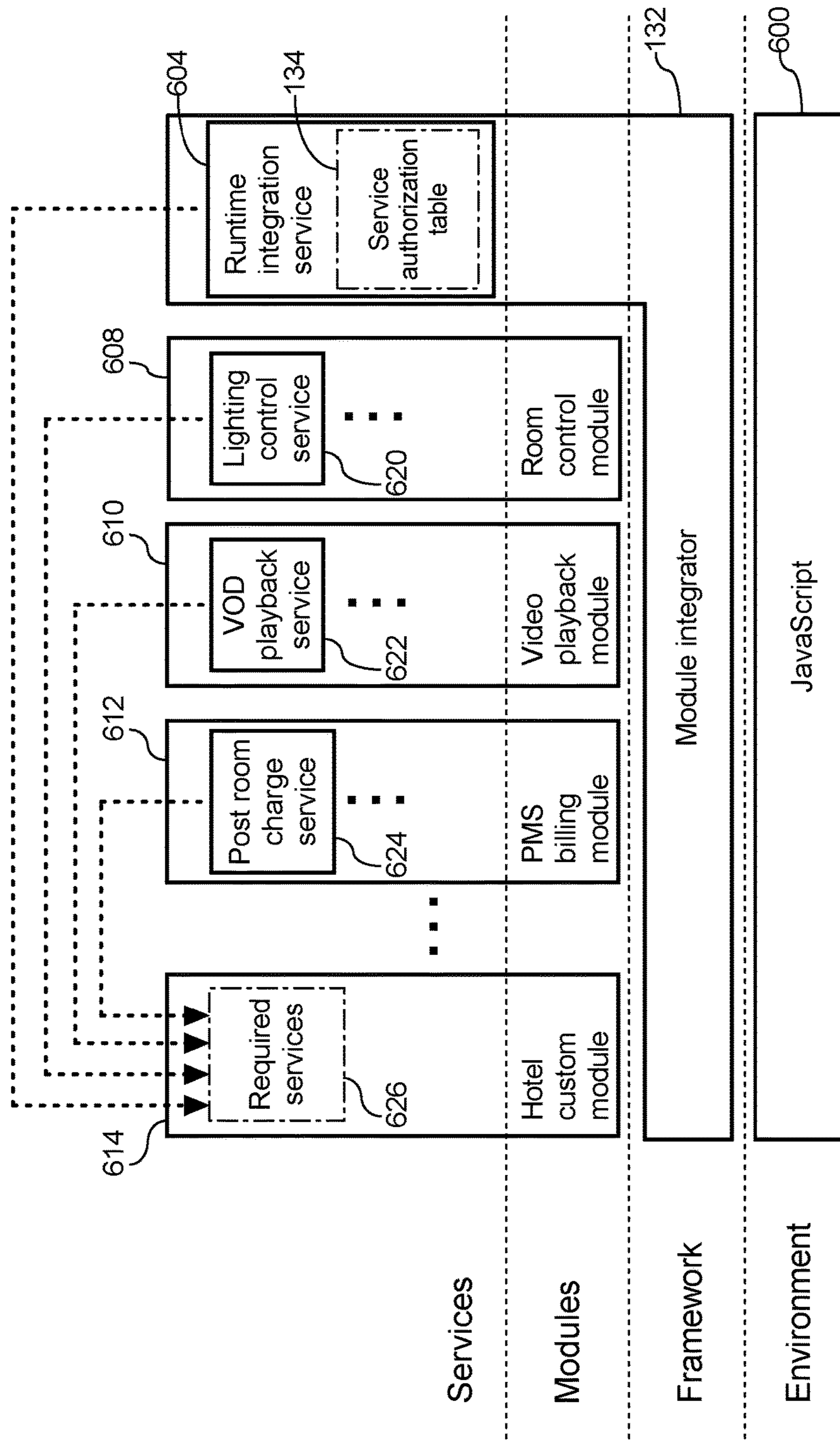

FIG. 6



134

<b>Service authorization table</b>	
<b>Module</b>	<b>Authorized service(s)</b>
Hotel custom	<ul style="list-style-type: none"> <li>● Post room charge</li> <li>● VOD playback</li> <li>● Lighting control</li> </ul>
Video playback	<ul style="list-style-type: none"> <li>● Post room charge</li> </ul>
PMS billing	none
Room control	none

FIG. 7

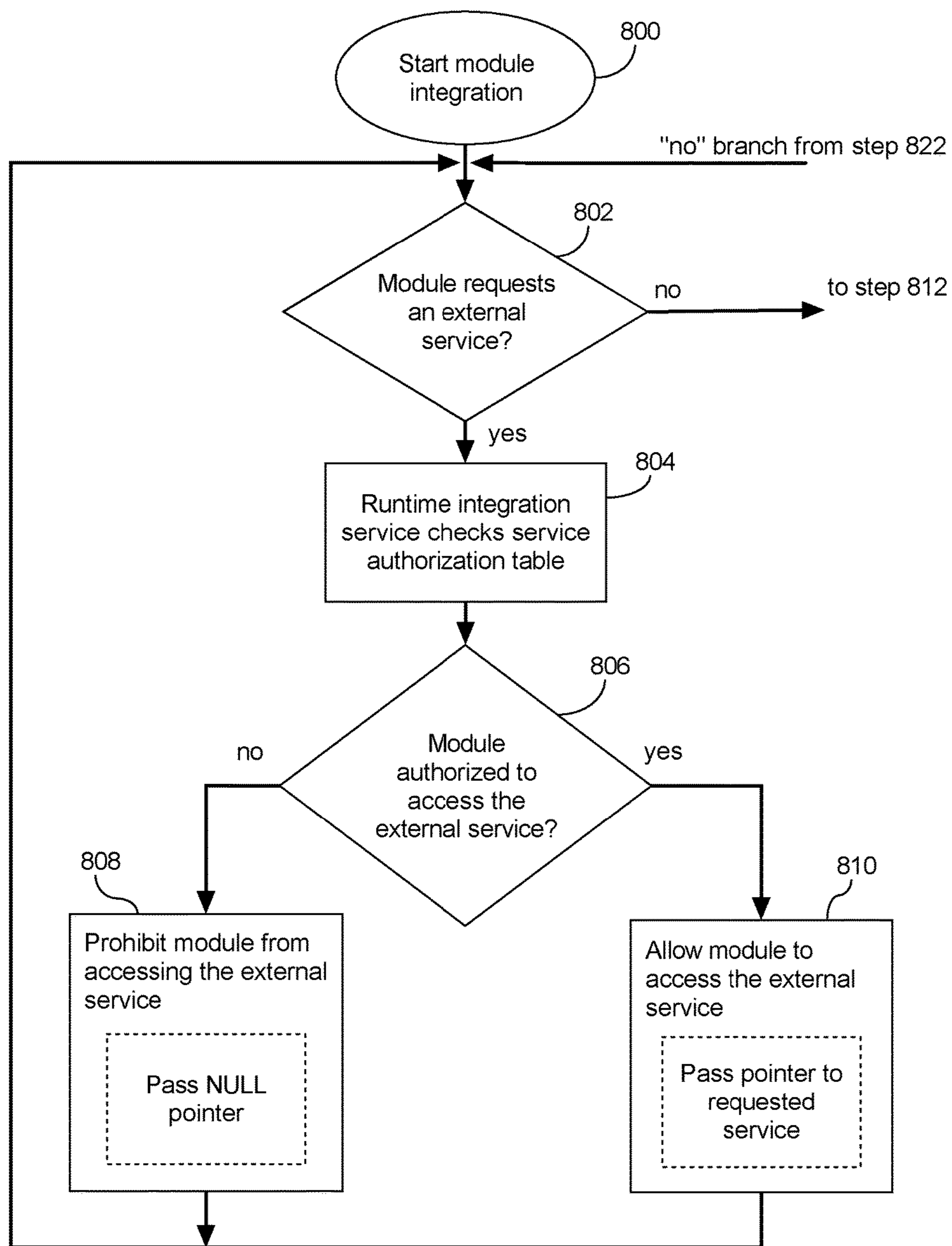

FIG. 8

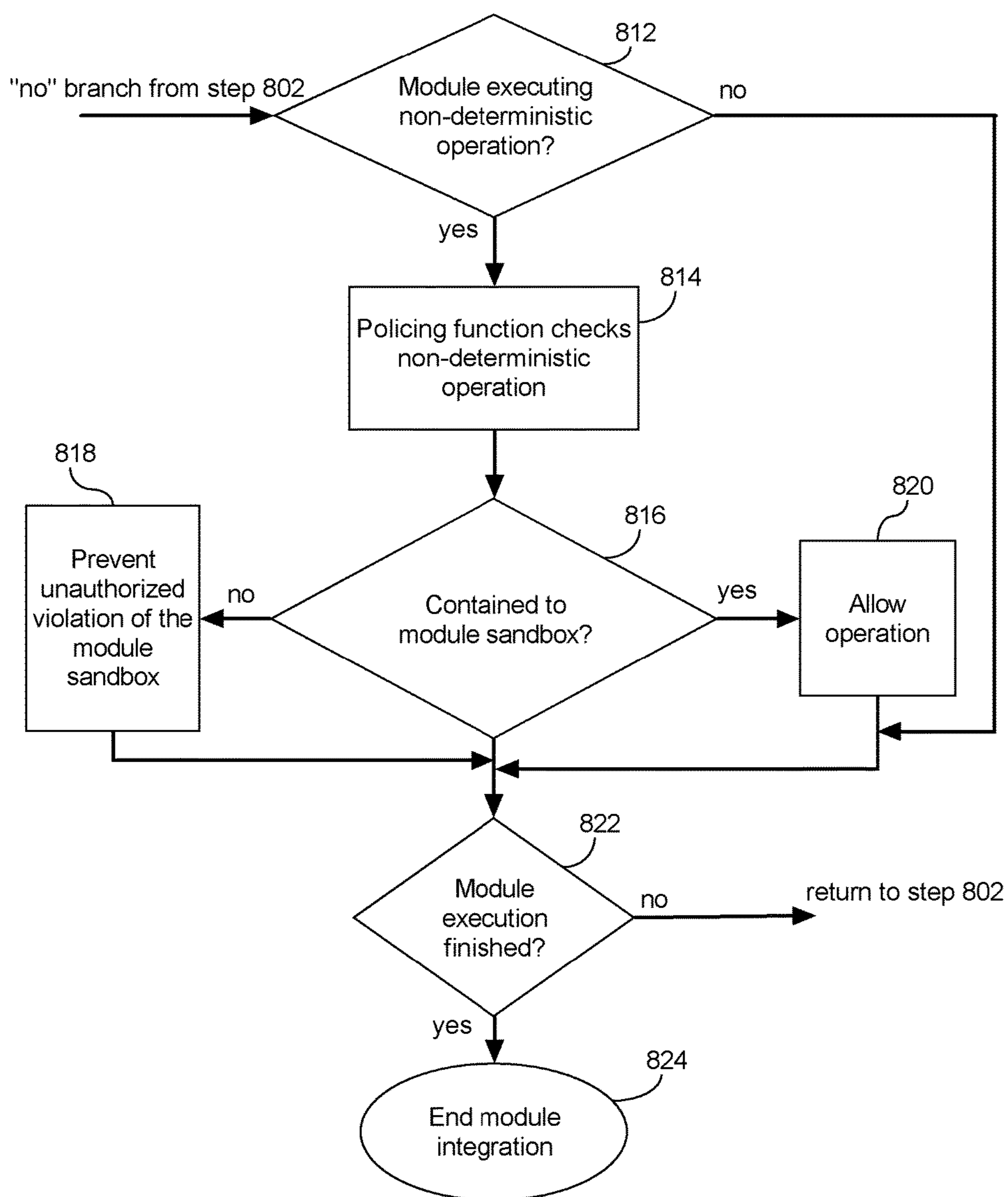

FIG. 9

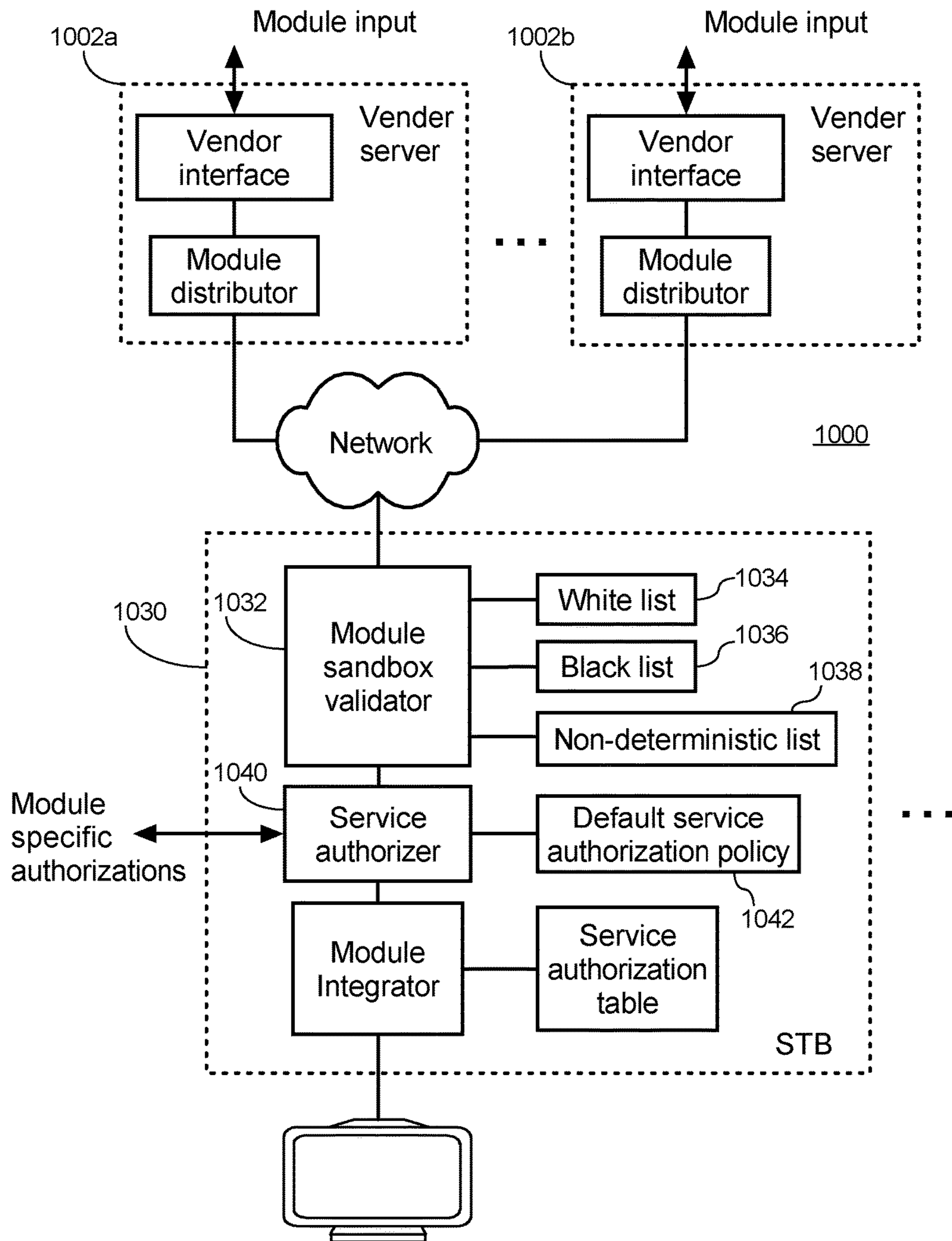

FIG. 10

**ALLOWING FIRST MODULE OF  
COMPUTER CODE TO MAKE USE OF  
SERVICE PROVIDED BY SECOND MODULE  
WHILE ENSURING SECURITY OF SYSTEM**

CROSS-REFERENCE TO RELATED  
APPLICATIONS

This application is a continuation of U.S. patent application Ser. No. 14/702,729 filed May 3, 2015, which is a continuation of U.S. patent application Ser. No. 14/063,172 filed Oct. 25, 2013, which is a continuation of U.S. patent application Ser. No. 13/108,167 filed May 16, 2011. All of these applications are incorporated herein by reference.

BACKGROUND OF THE INVENTION

1. Field of the Invention

The invention pertains generally to integrating modules of computer code for execution on a computing device. More specifically, the invention relates to containing each module within a sandbox and controlling during runtime the ability of each module to access services provided by other modules.

2. Description of the Related Art

Hotels often purchase in-room entertainment and control systems from one or more outside vendors. Typically, a primary vendor handles the overall system and deals directly with the hotel owners while subcontracting various sub-portions to secondary vendors who may or may not have direct contact with the hotel owners. For example, a primary vendor may provide high speed Internet access (HSIA) and video-on-demand (VOD) servers and in-room set-top boxes (STBs) while subcontracting a secondary vendor to design an electronic control system for controlling various aspects of the guest rooms. The primary vendor and secondary vendor may work together to integrate their portions of the system such as to allow a guest to utilize a single infrared remote control device and an in-room television to browse the Internet, watch television (TV) and movies, and operate the in-room air-conditioner, lights, windows, and curtains.

After the system goes live, hotel management often desire to further customize and enhance the system. For example, management may wish to include a new feature unique to the hotel to distinguish the hotel from other hotels. In this situation, management typically contacts the primary vendor of the entertainment system to request incorporation of a special request or to add one or more new functions. Often the requested functions are very specific to the particular hotel and would not be useful or desirable to incorporate at other hotels. In addition to making direct changes to the system, the primary vendor may need to contact one or more secondary vendors if the requested feature involves interfacing with a secondary vendor's portion of the system.

It is inconvenient for hotel management to have to make these feature requests and to be limited to dealing only with the primary vendor. It would be beneficial if hotel management could simply make the changes to the system themselves such as by allowing a technical consultant or other third-party access to add a new feature to the installed entertainment system. It is likewise a financial and time burden on the primary and secondary vendors to handle these one-off feature requests for different hotels.

However, allowing the hotel or a third-party vendor to directly modify or add new features could cause stability problems since third-parties may not understand the system as whole. For example, in order to add a function to an

in-room STB, a JavaScript program that controls the functions of the STB may need to be modified. Executing third-party JavaScript code on the in-room STB is risky both in terms of stability and security. Bugs may be inadvertently (or deliberately) introduced, and a malfunctioning third-party script has the potential to crash an in-room STB or interfere with the rest of the system. Security of guest data, hotel data, and media content is also a concern because each script running on the STB has unlimited access to the network and other valuable data within the STB. Content providers such as Hollywood studios have strict rules regarding encryption keys and content protection, and the primary system vendor must protect media assets such as pay-per-view and VOD content at all times. Giving untrusted third-party vendor code unlimited access to all functions of the STB is unacceptable under these rules.

Sandboxing is a well-known computer security technique utilized to isolate running computer programs from each other. Although JavaScript is a very insecure programming language, it is possible to "sandbox" a particular script by limiting the instructions and commands executable by the script according to the object-capability model. Generally speaking there are two approaches to using this capability-based security model to perform sandboxing on JavaScript: verification and translation.

The verification approach involves automatically checking before execution that a script is written entirely using a limited subset of the JavaScript language including only "safe" commands and language features that ensure the script is sandboxed. The original script is not changed at all during the verification process so verified scripts run at their native speed and with exactly their intended behavior. Only scripts that first pass the verification process are ensured to be isolated within their own sandbox and are allowed to be run. Scripts including one or more unsafe commands that could be used to act on or modify any information outside the sandbox fail the verification and cannot be run. ADsafe™ is an example of a nondestructive JavaScript verification tool that can be utilized to verify that a script is sandboxed at any stage of the deployment pipeline or after delivery as part of compliance testing.

The translation approach involves automatically translating a potentially unsafe original script file into a translated script file, which utilizes only code and language features that can be guaranteed at runtime to stay within the confines of a given set of sandbox rules. The Google™ Caja project is an example of a source-to-source JavaScript translator for securing JavaScript-based web content using this type of translation approach. Caja provides a compiler called a "cajoler" that generates a "cajoled" web application from a fail-stop subset of JavaScript that includes almost the entire JavaScript language except for a few error-prone constructs. Caja further allows for a wide range of flexible security policies including allowing a containing page to grant authority for an embedded application to access a particular web service.

Although the above verification and translation approaches are both viable options for including active content from untrusted third-parties into regular web sites, neither is optimal in an embedded environment such when running scripts on a STB in a hotel entertainment system. Due to limiting each script to its own sandbox, the verification approach impedes sharing functionality and information between scripts provided by different vendors. In this way, the verification approach is useful for inserting stand-alone active content such as advertisements or independent features that are not closely integrated with the existing

system; however, hotel management may wish to add a new script to provide a feature on the STB that requires close integration with data and/or services provided by code already existing on the STB. Caja allows granting and denying authority to web services by passing and denying access to objects; however, a downside is the significantly increased length of the cajoled (i.e., translated) web applications and the resulting computational power requirements by devices executing the cajoled scripts. Caja is designed for web browsers running on modern personal computers, which may be orders of magnitude faster than a STB or other in-room embedded device typical found in a hotel entertainment system. In addition to running slower, the translated script file may also have new bugs or unexpected behaviors introduced by the Caj a translation process itself, which further complicates testing and quality assurance efforts.

#### SUMMARY OF THE INVENTION

According to an exemplary embodiment of the invention there is disclosed a system for integrating a plurality of modules of computer code. The system includes a sandbox validator configured to receive a first module of computer code and parse the computer code of the first module in order to verify that the first module complies with one or more sandbox constraints. The sandbox constraints include requiring that the first module does not include computer code attempting to access variables having a global scope and does not include computer code attempting to access information from outside the first module that is not directly passed to the first module. The system also includes a computing device configured to execute the first module within a runtime environment. A module integrator operates within the runtime environment and is configured to receive a request from the first module to access a service provided by a second module of computer code available on the computing device; allow the first module to access the service when the first module is authorized to access the service according to a service authorization table; and prevent the first module from accessing the service when the first module is not authorized to access the service according to the service authorization table.

According to another exemplary embodiment of the invention there is disclosed a method of integrating a plurality of modules of computer code. The method includes receiving a first module of computer code at a sandbox validator; and parsing, by the sandbox validator, the computer code of the first module in order to verify that the first module complies with one or more sandbox constraints. The sandbox constraints include requiring that the first module does not include computer code attempting to access variables having a global scope and does not include computer code attempting to access information from outside the first module that is not directly passed to the first module. The method further includes executing the first module within a runtime environment on a computing device; and receiving, by a module integrator operating within the runtime environment, a request from the first module to access a service provided by a second module of computer code available on the computing device. The method further includes allowing, by the module integrator, the first module to access the service when the first module is authorized to access the service according to a service authorization table; and preventing, by the module integrator, the first module from accessing the service when the first module is not authorized to access the service according to the service authorization table.

According to another exemplary embodiment of the invention there is disclosed a system for integrating a plurality of modules of computer code for execution. The system includes a control server configured to provide functionality of a sandbox validator. The sandbox validator receives a first module of computer code and parses the computer code of the first module in order to verify that the first module complies with one or more sandbox constraints. The sandbox constraints at least require that the first module does not include computer code attempting to access variables having a global scope and does not include computer code attempting to access information from outside the first module that is not directly passed to the first module. The system further includes a computing device coupled to the control server via a computer network. The computing device receives the first module from the control server via the computer network and executes the first module within a runtime environment. The computing device is also configured to provide functionality of a module integrator operating within the runtime environment. The module integrator receives a request from the first module to access a service provided by a second module of computer code available on the computing device, allows the first module to access the service when the first module is authorized to access the service according to a service authorization table, and prevents the first module from accessing the service when the first module is not authorized to access the service according to the service authorization table.

According to another exemplary embodiment of the invention there is disclosed a system for integrating a plurality of modules of computer code. The system includes a computer server having one or more processors coupled to memory and a network interface. By the one or more processors executing instructions loaded from the memory, the one or more processors are configured to provide a vendor interface accessible via the network interface, the vendor interface operable to receive a first module of computer code from a vendor; a sandbox validator operable to parse the computer code of the first module in order to verify that the first module complies with one or more sandbox constraints; a service authorizer operable to generate a service authorization policy for the first module, the service authorization policy indicating which services provided by a second module of computer code are allowed to be accessed by the first module; and a module distributor operable to send the first module along with the service authorization policy to a computing device that already includes the second module. The system further includes the computing device. When executing the first module, a module integrator running on the computing device only allows the first module to access a particular service provided by the second module when the first module is authorized to access the particular service according to the service authorization policy.

According to another exemplary embodiment of the invention there is disclosed a method of integrating a plurality of modules of computer code. The method includes providing a vendor interface accessible via a network interface of a computer server; receiving a first module of computer code from a vendor via the vendor interface; and parsing, by a sandbox validator, the computer code of the first module in order to verify that the first module complies with one or more sandbox constraints. The method further includes generating, by a service authorizer, a service authorization policy for the first module, the service authorization policy indicating which services provided by a second module of computer code are allowed to be accessed by the

5

first module; and sending the first module along with the service authorization policy to a computer device that already includes the second module. When the computing device executes the first module, a module integrator running on the computing device only allows the first module to access a particular service provided by the second module when the first module is authorized to access the particular service according to the service authorization policy.

According to another exemplary embodiment of the invention there is disclosed a system for integrating a plurality of modules of computer code. The system includes a memory storing a plurality of instructions and one or more sandbox constraints, a communication interface, and one or more processors coupled to the memory and the communication interface. By the one or more processors executing the instructions loaded from the memory, the one or more processors are configured to provide a sandbox validator operable to parse computer code of a first module received via the communication interface in order to verify that the first module complies with the one or more sandbox constraints. The one or more processors further provide a service authorizer operable to generate a service authorization policy for the first module. The service authorization policy indicating which services provided by a second module of computer code are allowed to be accessed by the first module. The one or more processors further provide a module integrator operable to only allow the first module to access a particular service provided by the second module when the first module is authorized to access the particular service according to the service authorization policy.

According to another exemplary embodiment of the invention there is disclosed a method of integrating a plurality of modules of computer code. The method includes receiving a first module of computer code from via a communications interface, and parsing, by a sandbox validator, the computer code of the first module in order to verify that the first module complies with one or more sandbox constraints. The method further comprises generating, by a service authorizer, a service authorization policy for the first module. The service authorization policy indicating which services provided by a second module of computer code are allowed to be accessed by the first module. The method further comprises only allowing, by a module integrator, the first module to access a particular service provided by the second module when the first module is authorized to access the particular service according to the service authorization policy.

According to another exemplary embodiment of the invention there is disclosed a non-transitory computer readable storage medium comprising instructions that when executed by one or more processors cause the one or more processors to perform any of the above-described methods.

One advantageous use of the present invention is to allow third-party vendors to add advanced functionality to a hotel's entertainment system in a secure and safe manner. A further advantage is new computer code modules may be added with limited involvement of one or more vendors originally responsible for the system.

These and other embodiments and advantages of the embodiments of the present invention will become apparent from the following detailed description, taken in conjunction with the accompanying drawings, illustrating by way of example the principles of the invention.

#### BRIEF DESCRIPTION OF THE FIGURES

FIG. 1 illustrates a block diagram of a system for integrating a plurality of modules of computer code according to an exemplary configuration of the present invention.

6

FIG. 2 shows an exemplary white list of FIG. 1 including allowed JavaScript operations and language features.

FIG. 3 shows an exemplary black list of FIG. 1 including operations and language features that are prohibited from use by vendor modules.

FIG. 4 illustrates an exemplary non-deterministic list of FIG. 1 including a list of non-deterministic operations and their appropriate policing functions.

FIG. 5 is a flowchart of operations that may be performed by the sandbox validator of FIG. 1 to verify that a module complies with a set of sandbox constraints.

FIG. 6 illustrates an exemplary architectural view of execution layers running on a STB of FIG. 1.

FIG. 7 illustrates an example service authorization table that could be used to support the hotel custom module shown in FIG. 6.

FIG. 8 and FIG. 9 together illustrate an exemplary operational flowchart of steps that may be performed by the module integrator of FIG. 1 at runtime to ensure the operations of a vendor module comply with the sandbox constraints and to control the ability of the module to access one or more services offered by other modules.

FIG. 10 illustrates a block diagram of a system for integrating a plurality of modules of computer code according to another exemplary configuration of the present invention.

#### DETAILED DESCRIPTION

FIG. 1 illustrates a block diagram of a system 100 for integrating a plurality of modules of computer code according to an exemplary configuration of the present invention. In this configuration, one or more control servers 102 are coupled via a network 120 to a plurality of computing devices such as set-top boxes (STBs) 130. Each STB 130 includes a web browser application operating within the STB for executing interpreted computer code such as JavaScript modules to provide hotel entertainment and control system functions to the guest. In one example, the control server 102 may be installed at the hotel and communicate with a plurality of STBs 130 installed in various guest rooms via the hotel's local area network (LAN) 120. In another example, the control server 102 may be installed at a central location such as an Internet connected data center and communicate with a plurality of STBs 130 installed in guest rooms in a plurality of hotels via network 120 formed by the Internet and/or hotel LANs. The control server 102 may validate a newly added vendor module, generate a service authorization policy for the new module, centrally store the module and service authorization policy, and distribute the module and its associated service authorization policy to the various STBs 130/hotels/other computing devices when required. As shown in FIG. 1, it is also possible to have more than one control server 102 each validating, authorizing, and/or distributing different modules.

In this configuration, the control server 102 includes a vendor interface unit 104, a module sandbox validator unit 106, a service authorizer unit 114, and a module distributor unit 118. Vendors utilize the vendor interface 104 to add their own modules to the system 100. To ensure security, the vendor interface 104 may require user authentication before allowing the vendor to add their code modules. Vendors may also utilize the vendor interface 104 to retrieve information regarding the status of their module(s) or to receive data returned from their module(s) such as from individual STBs 130. For example, some vendors may wish to implement

interactive functions that will require the user to input data at the STB 130, which may be received by the vendor utilizing the vendor interface 104. Besides a physical console available to vendors, the vendor interface 104 may also be implemented in a virtual manner such as a web based portal or networked application programming interface (API) allowing vendors to remotely interact with the control server 102 through a computer network such as the Internet.

When an external vendor module is added, object capability restrictions are used to verify the code of the module is sandboxed and will not affect or access anything outside its sandbox except external services for which it requests access at runtime. In this configuration, these checks are done by the module sandbox validator 106 before the module code is sent to the STBs 130 for execution. A benefit of performing these checks in advance at a central control server 102 is that the burden on each STB 130 is reduced. The STBs 130 typically run an interpreted language such as JavaScript and have minimal system resources. This means there are no sandboxing capabilities built-in to each STB 130, and implementing a full sandbox in JavaScript or some other interpreted language on the STB 130 would run too slowly.

In this configuration, the sandbox validator 106 does not modify the code of the incoming vendor modules while performing the above mentioned checks. Instead, the module sandbox validator 106 verifies vendor modules comply with a set of sandbox constraints including a white list 108 of allowable JavaScript operations, a black list 110 of prohibited JavaScript operations, and a non-deterministic list 112 of JavaScript operations that may be permitted but cannot be determined safe before runtime. Each line of module code may be parsed to ensure that only an approved subset of language constructs are utilized. The three lists 108, 110, 112 may be predefined and published in advance so the external vendors know to use the approved commands and not prohibited commands. For example, FIG. 2 shows an exemplary white list 108 including allowed JavaScript operations and language features, FIG. 3 shows an exemplary black list 110 including operations and language features that are prohibited from use by vendor modules, and FIG. 4 illustrates an exemplary non-deterministic list 112 including a list of non-deterministic operations and their required runtime policing functions.

Because the lists 108, 110, 112 may be provided to the vendor in advance, if the full computer language provides many ways to perform a desired task, the vendor will choose an implementation technique using the approved sub-set of the language in compliance with the lists 108, 110, 112. This avoids the inefficiencies caused by computer translation such as when an automatic translator takes unsafe but efficient code and translates it into safe but inefficient code.

The approved subset of operations may not include all the capabilities of the full language. For example, a “reboot STB” operation may not be allowed to be performed by a particular external vendor module whereas a “print text on screen” operation may be allowed. When a forbidden operation or command is encountered, the sandbox validator 106 may return an error with debug information to the external vendor via the vendor interface 104 so they can fix the problem. This information could be displayed in real time as a part of the interface 104 that the vendors use to submit their code, or could be done at a later time and then passed back to the vendor such as via email or allowing the vendor to log in to a web site acting as the vendor interface 104 to see the results.

The module sandbox validator 106 may also ensure that non-deterministic operations included on the non-deterministic list 112 are wrapped within an appropriate policing function. The policing functions are provided by the module integrator 132 during execution and confirm non-deterministic operations behave in a way that is compliant with the sandbox rules for the module.

In the example shown in FIG. 4, the special JavaScript variables `this` and arguments must be wrapped with policing functions as `check(this)` and `toArray(arguments)`, respectively. The check function is provided by the module integrator 132 to confirm at runtime that the variable `this` is not the global object having global scope; if it is, the check function throws an error and prevents the module from performing that operation. The reason for this policing function is to prevent the special variable `this` from being utilized to access information outside the scope of the module sandbox. Similarly, the `toArray` function converts the special arguments variable into a simple array only including the parameters that were passed as arguments and none of the other information that is normally also included in the arguments variable. This ensures a module cannot access information from outside its scope that was not deliberately passed to the module. Additionally, loops are wrapped by a `loopTimer` function to prevent infinite (and long duration) loops by timing the duration of the loop and aborting the loop if the time exceeds a predetermined duration.

In this configuration, the module undergoing validation is not modified by the sandbox validator 106. Therefore, the vendor must ensure the proper policing functions (e.g., `check`, `toArray`, `loopTimer`) are utilized and the validator 106 simply verifies the functions are in place according to the non-deterministic list 112. One benefit of having the vendor include the policing functions in the module rather than having the sandbox validator 106 automatically add them is that successfully validated modules will not have been modified by the sandbox validator 106. The code for the policing function can be made available to the vendor, and, in this way, the vendor will be able to accurately test the module before integration with the system 100 because it includes the policing functions during both testing and deployment. In another configuration where this benefit is not required or as a backup in case the vendor forgets to add a particular policing function, the sandbox validator 106 may be configured to automatically modify the module to include the appropriate policing functions where needed.

It should be noted that the three policing functions (`check`, `toArray`, `loopTimer`) are described to show useful examples; however, the invention is not limited to only these three policing functions. Likewise, the white list 108 and black list 110 are not limited to only the approved and prohibited JavaScript language features shown, respectively. These lists 108, 110, 112 may be modified according to design requirements such as the computer language used to implement vendor modules. Additionally, the sandbox validator 106 may automatically utilize different lists 108, 110, 112 or automatically apply features on each list only to certain vendor modules such that some modules have tighter sandbox constraints than others. Modules names or other identifiers may be utilized by the sandbox validator 106 to determine the applicable sandbox constraints to validate for each module.

Ensuring each module correctly identifies itself when requesting access to services is another function of the module sandbox validator 106 in this example. As this function is closely related to runtime module integration,



before understanding the significance of this verification, it is helpful to first understand how the module integrator **132** functions during execution on the STB **130** to permit and deny modules from accessing services provided by other modules. According to the present invention, modules may be authorized at runtime to access services provided by other modules. Services may be utilized to receive data from existing aspects of the hotel's entertainment system, to provide data to other parts of the system, to call functions and procedures (which are types of services) related to other modules, and/or to provide functions and procedures to the other modules. During module execution by the STB **130**, a module may request access to one or more services provided by other modules on the STB **130**. The access request may be performed by calling a runtime integration service provided by the module integrator **132**. Module integrator **132** either grants or denies the request according to a service authorization table **134**. In one configuration, the request may be made at load time of the module by specifying the name of the requesting vendor module and the names of the desired external services as follows:

---

```
runtime_integration ("Module_Name",      |
["Requested_service_name_1"],          |
["Requested_service_name_2"], . . . ,  |
function(Pointer_to_requested_service_1, |
Pointer_to_requested_service_2, . . . ) |
{ code }                                |
```

---

where: `runtime_integration` is a service provider by the module integrator **132** utilized to provide execution pointers so modules can call services provided by other modules, `Module_Name` is the name of the current module (i.e., the module making the request), `Requested_service_name_N` are the names of the requested services as provided by other modules, `Pointer_to_requested_service_N` are pointers returned by the module integrator **132** being either a valid pointer to the execution addresses of the requested service when the module is authorized to access that service or an invalid pointer when the module is not authorized, and `{code}` is the JavaScript code of the vendor module being a series of operations executed as a function and utilizing the service pointers received from the module integrator **132**.

In the code section, the module may also define one or more services that may be made available to other modules running on the STB **130** using a similar process. These vendor provided services may be registered with the module integrator **132** using a `register_service` function so that module integrator **132** will record the name of the service and a valid execution addresses in order to pass a pointer to other modules that are authorized to use this service. An example of registering a service with the module integrator **132** in JavaScript is as follows:

```
register_service ("Service_name", {service code})
```

where: `register_service` is the registration service provided by the module integrator **132**, `Service_name` is the name of the service provided by the vendor module and that may be used by other modules if they are authorized according to the service authorization table **134**, and `service_code` is the JavaScript code of the service. In this way, all modules may both request access to external services and provide services to other modules. The module integrator **132** utilizes the service authorization table **134** to determine which modules may access which services and then authorizes and denies access by passing valid and invalid pointers accordingly.

Returning again to the module sandbox validator unit **106**, because different module names may be authorized to access different services, during module validation, the module sandbox validator **106** ensures that the `Requesting_Module_Name` correctly identifies the name of the module being validated. This may be done by either failing validation if the module reports another module's name or by inserting the module's correct name. In addition to module names, other types of module identifiers associated with the module may be used for this purpose, for example, unique serial numbers, module names or addresses, and/or vendor codes. The result is the sandbox validator **106** ensures the module does not forge another module's identifier in order to gain unauthorized access to one or more services at runtime.

FIG. **5** is a flowchart of operations performed by the module sandbox validator unit **106** to verify that a module complies with a set of sandbox constraints defined by the white list **108**, black list **110**, and non-deterministic list **112** shown in FIG. **1** according to one exemplary configuration. The steps of the flowchart are not restricted to the exact order shown, and, in other configurations, shown steps may be omitted or other intermediate steps added. In this configuration, the module sandbox validator unit **106** performs the following operations:

**Step 500:** The module sandbox validation process begins when the sandbox validator **106** receives a new module. For example, this may occur when a hotel or third-party vendor submits a new JavaScript module file for execution on one or more STBs **130** using the vendor interface **104**.

**Step 502:** The sandbox validator **106** automatically parses the first operation of the incoming module into one or more tokens. Tokens may be pieces of a command, the command itself, or properties of the commands such as whether it operates on global variables, forms a loop, uses a particular reserved word, etc. For example, all the various JavaScript language features included on the lists **108**, **110**, **112** of FIG. **2**, FIG. **3**, FIG. **4** are examples of tokens that may be detected at this step.

**Step 504:** Is the current operation attempting to request access to an external service? This may be determined if one of the tokens corresponds to a request to the `runtime_integration` service described above, for example. If yes, control proceeds to step **506**; otherwise, control proceeds to step **508**.

**Step 506:** When requesting access to the external service, does the module correctly identify itself to the runtime integration service? For example, does the `Module_Name` reported by the module when calling the `runtime_integration` service match the name of the module undergoing validation? If yes, control proceeds to step **508**; otherwise, control proceeds directly to step **516** to fail validation and prevent the module from impersonating another module at runtime.

**Step 508:** Are all the tokens of the current operation on the white list **108**? Specific matches of tokens on the white list **108** may correspond to exceptions of prohibited commands that are blocked by the black list **110**. For example, FIG. **2** shows an example of a white list **108** utilized to allow deterministic and safe uses of JavaScript that cannot escape a module sandbox. If all tokens of the current operation are on the white list **108**, control proceeds to step **518**; otherwise, control proceeds to step **510**.

**Step 510:** Are any tokens of the current operation on the black list **110**? Matches in this step indicate prohibited language features and control proceeds directly to step **516** to fail the validation. For example, FIG. **3** shows an example of black list **110** utilized to prohibit unsafe uses of JavaScript that may be utilized to escape a module sandbox. When the

## 11

current command does not correspond to any of the tokens listed on the black list **110**, control proceeds to step **512**.

Step **512**: Are any tokens of the current operation on the non-deterministic list **112**? The non-deterministic list **112** is utilized to detect commands that are permitted on the condition that they are wrapped with a runtime policing function because they may be unsafe or violate the module sandbox if used improperly and the only way to check them is at runtime. For example, FIG. **4** shows an example of the non-deterministic list **112** listing several non-deterministic tokens. If any token matches the non-deterministic list **112**, control proceeds to step **514**; otherwise, control proceeds to step **518**.

Step **514**: In order to ensure these non-deterministic operations are utilized properly, the sandbox validator **106** checks to see that the non-deterministic operation or token is wrapped with the appropriate runtime policing function. For example, FIG. **4** shows an example of non-deterministic list **112** showing non-deterministic JavaScript language features that are allowed as long as they are wrapped with the corresponding policing function. If the non-deterministic operations are properly wrapped with the corresponding policing function, control proceeds to step **518**; otherwise, control proceeds to step **516** to fail the validation.

Step **516**: Validation fails because the module does not comply with its sandbox constraints.

Step **518**: Is the current operation the last command of the module? If yes, control proceeds to step **522**; otherwise, control proceeds to step **520**.

Step **520**: The sandbox validator **106** automatically parses the next operation of the incoming module into one or more tokens and returns to step **504**.

Step **522**: Validation succeeds because all operations of the module comply with the sandbox constraints defined by the white, black, and non-deterministic lists **108**, **110**, **112** according to the name of the module undergoing validation.

Although in a preferred configuration the sandbox validator **106** does not modify the module code in any way so that validated modules run with exactly the same behavior and speed as they did during testing by the vendor, in another configuration, the validator may automatically modify the module code as required to enforce the above rules. For example, at step **506** the validator **106** may insert the module's correct identifier and in step **514** the module may wrap the non-deterministic operation with the required policing function.

The service authorizer **114** generates a service authorization policy for the vendor module according to either a default service authorization policy **116** and/or module specific authorizations **115** that may be received from an administrator for one or more specific modules. The service authorization policy specifies which external services the module is authorized to access during execution on one or more STBs **130**.

An existing service provided at each STB **130** may provide the name of the guest currently staying in the associated hotel room, and, by default, all vendor modules may be authorized to access this service according to the default service authorization policy **116**. The default service authorization policy **116** may contain a list of system-wide pre-authorized services applicable to all modules. In another example, the same on-screen user interface (UI) services may be authorized for all modules to allow a vendor module to position buttons and controls on the screen using the same UI skin (look and feel) as what the media system **100** currently uses. A hotel guest interacts with the STB **130** using a UI displayed on an in-room television **136** and

## 12

controlled by an infrared remote control device. Guests operating each STB **130** may not even necessarily know that some functions were implemented by different vendor modules.

An administrator may also configure the service authorizer **114** to either deny a particular module from accessing one or more services on the default policy **116** or may further authorize a particular module to access one or more services other than those listed on the default policy **116**. The service authorizer **114** may automatically generate a different service authorization policy for each vendor module according to the name or other identifier of the vendor module and module specific authorizations **115**. Then, the module and its associated service authorization policy are passed to the module distributor **118** for distribution. An administrator may be presented with lists of the modules in the system **100** and services requested by a new vendor module in order to configure module specific authorizations **115**. The service authorizer **114** may generate an updated service authorization policy for a module at any time. Upon receiving the updated service authorization policy, STBs **130** may update their service authorization tables **134** accordingly.

The module distributor **118** automatically transfers the module and its associated service authorization policy to one or more STBs **130** in the hotel. It is not necessary that all STBs **130** run the same modules; for instance, a first STB **130a** may operate using a set of modules different than a second STB **130b**. The module distributor **118** may be implemented as a web server from which the STBs **130** request and download a JavaScript program including a plurality of modules dynamically selected according to an identifier associated with the STB such as a room number. Alternatively, the module distributor **118** may push one or more modules and/or updated service authorization policies to one or more STBs **130**.

FIG. **6** illustrates an exemplary architectural view of execution layers running on a STB **130**. A first layer is formed by a regular JavaScript execution environment **600** such as may be provided within a web browser running on each STB **130**. The module integrator **132** operates within the JavaScript environment **600** as the framework for performing runtime policing functions and controlling each module's ability to access services provided by other modules. In this configuration, the module integrator **132** is itself a module executed by the JavaScript environment **600** and provides the runtime integration service **604**. The module integrator **132** may also provide other services (not shown) such as those required to run the various policing functions shown in FIG. **4** and a registration service allowing modules to offer to provide services to other modules, for example.

As explained earlier, the runtime integration service **604** authorizes the other modules **608**, **610**, **612**, **614** to integrate their services according to a service authorization table **134**. In this example, four modules **608**, **610**, **612**, **614** are illustrated including a room control module **608** provided a lighting control service **620**, a video playback module **610** providing a video-on-demand (VOD) playback service **620**, a property management billing module **612** providing a post room charge service **624**, and a hotel custom module **614**. The hotel custom module **614** is the vendor module in this example and includes a list of required services **626** in the form of a request to the runtime integration service **604** to access externally provided services **624**, **622**, **620**.

To help illustrate a beneficial usage of the present invention, in this example, the purpose of the hotel custom module **614** is to provide a feature movie experience as designed by hotel management. When a guest selects the feature movie

on a menu displayed on the in-room television **136**, the post room charge service **624** is utilized to automatically bill the guest by adding a charge to the room bill using the hotel's property management system (PMS), the VOD playback service **622** is utilized to automatically begin playback of the feature movie on the television **136**, and the lighting control service **620** is utilized to automatically dim the room lights at the beginning of the movie and then automatically flash the lights for effect at particular times during the movie such as during explosions. As can be seen from this simplified example, besides the runtime integration service, the hotel custom module **614** needs to access at least three services **620**, **622**, **624** provided by other modules **608**, **610**, **612**, respectively. The other modules **608**, **610**, **612** may be under the control of a different vendor or provider. Additionally, although not shown in FIG. 6, the hotel custom module **614** may also provide one or more services to other modules.

FIG. 7 illustrates an example service authorization table **134** that could be used to support the hotel custom module **614** shown in FIG. 6. The same service authorization table **134** may be present on all STBs **130** or different STBs **130a**, **130b** may have different service authorization tables **134a**, **134b** allowing modules access to different services. Different service authorization tables **134a**, **134b** may be automatically formed when the module distributor **118** sends different modules and service authorization policies to each STB **130** based on the type of hotel room such as standard, deluxe, penthouse, etc. In one configuration, each row of the service authorization table may correspond to that module's service authorization policy as generated by the service authorizer **114**. In this example, if the module distributor **118** does not send the hotel custom module **614** to a STB **130**, that STB **130** will not have the hotel custom module row in its service authorization table **134**. When the module distributor **118** sends the hotel custom module **614** and its associated service authorization policy to a STB **130**, that STB **130** will include row in the service authorization table **134**.

Each module may be authorized to access any number of services provided by other modules. In the example illustrated in FIG. 7, the hotel custom module **614** is authorized to access the post room charge service **624**, the VOD playback service **622**, and the lightening control service **620**. More than one module may be authorized to access a single service such as the post room charge service **624** being authorized for use by both the hotel custom module **614** and the video playback module **610**. Additionally, some modules, for example, the PMS billing module **612** and the room control module **608** in this example, may not be authorized to access any external modules, although these modules **608**, **612** may themselves provide services authorized to be accessed by other modules.

FIG. 8 and FIG. 9 together illustrate an exemplary operational flowchart of steps that may be performed by the module integrator **132** at runtime to ensure the operations of a vendor module comply with its sandbox constraints and to control the ability of the module to access one or more services offered by other modules. The steps of the flowchart are not restricted to the exact order shown, and, in other configurations, shown steps may be omitted or other intermediate steps added. In this configuration, the module integrator **132** operates within the runtime JavaScript environment **600** on each STB **130** and performs the following steps:

Step **800**: Module integration may start upon loading a module for execution on the STB **130**. In another configuration, module integration may occur and/or continue to

occur while the modules are executing. For illustration purposes, in this flowchart description, the phrase "the module" generally refers to a vendor module, and "another module" generally refers to a module different from the vendor module. For example, to help understand the flowchart with reference to the example shown in FIG. 6 and FIG. 7, the hotel custom module **614** may be considered "the module" and the video playback module **610** may be considered "another module". However, it should be noted that the module integrator **132** may be simultaneously utilized with a plurality of different modules in order to ensure sandboxing and service authorizations are maintained for a plurality of modules. By handling external service access requests, service registrations, and policing functions, all of which were verified as being properly included in the code of the module by the module sandbox validator **106**, the module integrator **132** is capable of dynamically controlling sandboxing and integration between any number of modules.

Step **802**: Is the module requesting an external service? The phrase "external service" in this flowchart refers to a service such as a function or procedure provided by another module. For example, with reference to the dashed lines in FIG. 6, the hotel custom module **614** may include a request to the runtime integration service **604** identifying itself as the hotel custom module **614** and asking the runtime integration service **604** to return valid pointers for the post room charge service **624**, VOD playback service **622**, and lighting control service **620**.

Step **804**: The runtime integration service **604** receives the request from the module and checks the service authorization table **134** to see if the module is authorized to access the requested service.

Step **806**: When the module is authorized to access the requested service according to the service authorization table **134**, control proceeds to step **810**; otherwise, control proceeds to step **808**. As mentioned, because the sandbox validator **106** has previously ensured that the module has correctly identified itself each time it requests access to an external service, it is not possible that the module could forge another module's name in order to obtain greater access to external services.

Step **808**: Because the module has requested access to a service for which it is not authorized, the runtime integration service **604** prevents the module from accessing the prohibited service by passing an invalid pointer such as NULL pointer as the execution address for the service.

Step **810**: Because the module is authorized to access the requested service, the runtime integration service **604** allows the module to access the external service by passing a valid pointer to the service's execution address in the JavaScript environment **600**.

Step **812**: Is the module executing a non-deterministic operation wrapped with a policing function? If yes, control proceeds to step **814**; otherwise, control proceeds to step **822**. As mentioned, in a preferred configuration, the sandbox validator **106** has already ensured the module code includes the appropriate policing function; however, in another configuration the module integrator **132** may automatically detect non-deterministic operations and wrap them with the appropriate policing function, for example, in advance or in real-time.

Step **814**: The policing function performs a runtime check to ensure the non-deterministic operation complies with the sandbox constraints.

Step **816**: Is the non-deterministic operation contained to the module sandbox **816**?

Step **818**: The policing function prevents execution of the non-deterministic operation when the runtime check determines that the non-deterministic operation does not comply with the sandbox constraints.

Step **820**: The policing function allows execution of the non-deterministic operation when the runtime check determines the non-deterministic operation complies with the sandbox constraints.

Step **822**: Is the module execution finished? If yes, control proceeds to the step **824** to end module integration; otherwise, control returns to step **802**.

Step **824**: Module integration is finished.

At steps **812** to **820**, in addition to functionality described for check, toArray, loopTimer illustrated in FIG. **4**, the policing functions may involve code that will check at runtime that a vendor's particular operation will not modify or read any variables for which it is not allowed. For example, reading a location specified by a pointer may be a non-deterministic operation if the sandbox validator **106** is unable to determine to where the pointer will point before runtime. Therefore, the read operation may be wrapped with a policing function that will check where the pointer points at runtime before allowing the operation to actually be executed.

If the policing function finds that the operation will access only memory and variables created by the vendor module code then it will allow the operation to execute on the STB **130**. Otherwise, it will halt the execution and branch control away from the vendor module. For example, the policing function may branch to a suitable error message to be displayed on the STB **130** at this point to help the external vendor debug the problem. Alternately, the policing function may branch to a section of code that returns status of the failed operation and any other debug information to the vendor via the hotel's network **120** and ultimately to the vendor interface **104**. For example, the error message could be sent to the vendor interface **104** that vendors use to access information received from STBs **130**. This way, the third-party vendors may collect bug information from all the STBs **130** throughout the hotel without having to physically go to the rooms to read error messages displayed by individual STBs **130** or to contact other vendors responsible for other portions of the entertainment system.

FIG. **10** illustrates a block diagram of a system **1000** for integrating a plurality of modules of computer code according to another exemplary configuration of the present invention. Units having the same names as used in the example of FIG. **1** generally behave similar to as previously described for FIG. **1**; however, the order and the location of the units are modified in FIG. **10**. In system **1000**, one or more vendor servers **1002** are coupled to each computing device, illustrated as STBs **1030** in this example. The vendor servers **1002** may be untrusted and therefore the module sandbox validator **1032**, the related lists **1034**, **1036**, **1038**, the service authorizer **1040**, and the default service authorization policy **1042** are located at each STB **1030**. Although, this increases the workload on each STB **130** and means that a single vendor module sent from a vendor server **1002** to a plurality of STB **130** will under go validation at each STB **130**, this configuration may be advantageous, for example, when providing a distributed software-as-a-service (SaaS) architecture because no central control server **102** need be utilized.

One advantageous use of the present invention is to allow third-party vendors to add advanced functionality to a hotel's entertainment system in a secure and safe manner. The third-party vendors may be provided information on an

allowed subset of the JavaScript language, required policing functions defined by the lists of FIG. **2**, FIG. **3**, and FIG. **4**, and services available from other modules in the system. The third party module may include a request to access one or more services provided within the hotel entertainment system. A primary vendor responsible for the system as a whole may configure or customize a service authorization policy for the new module to allow it access to its required services and no other services. In this way, new computer code modules may be added with limited involvement of one or more vendors originally responsible for the system. Further, because the modules do not undergo inefficient translation process in one configuration, they continue to run at full speed and with their intended behavior.

In summary, a system for integrating modules of computer code may include a sandbox validator for receiving a first module and verifying that the first module complies with one or more sandbox constraints. A computing device may execute the first module within a runtime environment. A module integrator may operate within the runtime environment for receiving a request from the first module to access a service provided by a second module and only allowing the first module to access the service when the first module is authorized to access the service according to a service authorization table. The sandbox validator may ensure the first module correctly identifies itself when requesting a service provide by another module and that the first module includes runtime policing functions for non-deterministic operations. A service authorizer may generate an authorization policy for the first module, which is sent to the computing device along with the first module.

Although the invention has been described in connection with a preferred embodiment, it should be understood that various modifications, additions and alterations may be made to the invention by one skilled in the art without departing from the spirit and scope of the invention. For example, with reference to FIG. **1** and FIG. **10**, although it is beneficial to locate the module sandbox validator unit **106**, **1032** prior to the service authorizer unit **114**, **1040** to avoid unnecessary processing by the service authorizer **114** should the module code fail validation, this is not a requirement and the order may be interchanged or performed in parallel. JavaScript has been utilized to illustrate one example of the invention; however, this is not a limitation and other languages may utilized to code the modules and the same principles of the invention apply in a similar manner. When describing how policing function are "wrapped" around non-deterministic operations, this language is also intended to include adding the policing functions either in advance by the module author or automatically by the sandbox validator and at any position in the vendor module to allow the required runtime check and error handling. Additionally, module storage (long term and temporary) may be included at any stage in the system **100**, **1000** in order to store modules for later distribution and/or execution.

It should also be noted that in the above description illustrative words such as vendor, administrator, owner, hotel management, third-party, etc are simply meant as examples of different types of users to help provide an understanding of one beneficial application of the invention; however, in other applications, other types of users may equally apply. Examples of other applications include but are not limited to usage at hotels, motels, resorts, hospitals, apartment/townhouse complexes, restaurants, retirement centres, cruise ships, busses, airlines, shopping centres, passenger trains, etc. Although, particularly beneficial when integrating vendor modules authored by different entities, in

practice all modules may be authored by a same entity. For example, a single corporation may utilize the invention to integrate modules all written in-house, in a safe and secure manner. STBs **130** are chosen as the computing device to help illustrate one beneficial usage of the present invention; however, the described technology is equally applicable to other types of computing devices. Examples of other types of computing devices include but are not limited to set-top boxes, televisions, displays, mobile phones, laptop computers, notebook computers, desktop computers, tablet computers, personal digital assistants (PDAs), embedded devices, etc.

The above description describes elements of a system **100, 1000** that may include one or more units, some of which are explicitly shown in the figures, others that are not. As used herein, the term “unit” may be understood to refer to computing software, firmware, hardware, and/or various combinations thereof. It is noted that the units are exemplary. For example, one or more processors (not shown) may operate pursuant to instructions stored on a storage medium to provide the functions as described for the units. The units may also be combined, integrated, separated, and/or duplicated to support various applications. Also, a function described herein as being performed at a particular unit may be performed at one or more other units and/or by one or more other devices instead of and/or in addition to the function performed at the particular unit. Further, the units may be implemented across multiple devices and/or other components local or remote to one another, and the units may be moved from one device and added to another device, and/or may be included in both devices. In addition to a dedicated physical computing device, the word “server” may also mean a service daemon on a single computer, virtual computer, or shared physical computer, for example. The expression “at runtime” includes the state of a module at the time execution starts and also during execution by one or more processors of a computing device. Additionally, all combinations and permutations of the above described features, configurations, and examples may be utilized in conjunction with the invention.

What is claimed is:

**1.** A system for integrating a plurality of modules of computer code, the system comprising:

a memory storing a plurality of instructions and one or more sandbox constraints;

a communication interface; and

one or more processors coupled to the memory and the communication interface;

wherein, by the one or more processors executing the instructions loaded from the memory, the one or more processors are configured to provide:

a sandbox validator operable to parse computer code of a first module received via the communication interface in order to verify that the first module complies with the one or more sandbox constraints;

a service authorizer operable to generate a service authorization policy for the first module, the service authorization policy indicating which services provided by a second module of computer code are allowed to be accessed by the first module; and

a module integrator operable to only allow the first module to access a particular service provided by the second module when the first module is authorized to access the particular service according to the service authorization policy.

**2.** The system of claim **1**, wherein the sandbox constraints at least require that the first module does not include

computer code attempting to access variables having a global scope and does not include computer code attempting to access information from outside the first module that is not directly passed to the first module.

**3.** The system of claim **1**, wherein the module integrator is further configured to:

allow the first module to access the particular service by passing to the first module a pointer to an execution address of the particular service when the first module is authorized to access the particular service according to the service authorization policy; and

prevent the first module from accessing the particular service by passing to the first module an invalid pointer as the execution address of the particular service when the first module is not authorized to access the particular service according to the service authorization policy.

**4.** The system of claim **1**, wherein, when parsing the computer code of the first module, the sandbox validator is further operable to ensure when the first module requests access to the particular service provided by the second module that the first module correctly identifies itself with a module identifier associated with the first module.

**5.** The system of claim **1**, wherein:

the sandbox validator is further operable to automatically parse each operation of the first module into one or more tokens and ensure that a non-deterministic operation is checked with a policing function, the non-deterministic operation corresponding to an operation having at least one token listed on a non-deterministic list; and

the module integrator is further configured to provide the policing function during execution of the first module to perform a runtime check of the non-deterministic operation, allow execution of the non-deterministic operation when the runtime check determines the non-deterministic operation complies with the sandbox constraints, and prevent execution of the non-deterministic operation when the runtime check determines that the non-deterministic operation does not comply with the sandbox constraints.

**6.** The system of claim **1**, wherein the service authorizer is operable to automatically generate the service authorization policy according to a default system-wide service authorization policy.

**7.** The system of claim **1**, wherein the service authorizer is operable to automatically generate the service authorization policy according to a module-specific authorization policy and an identifier of the first module.

**8.** The system of claim **1**, wherein the first and the second modules are written in JavaScript.

**9.** The system of claim **1**, wherein the service authorizer is further operable to dynamically update the service authorization policy for the first module.

**10.** The system of claim **1**, wherein the system is a media entertainment system.

**11.** A method of integrating a plurality of modules of computer code, the method comprising:

receiving a first module of computer code from via a communications interface;

parsing, by a sandbox validator, the computer code of the first module in order to verify that the first module complies with one or more sandbox constraints;

generating, by a service authorizer, a service authorization policy for the first module, the service authorization

## 19

policy indicating which services provided by a second module of computer code are allowed to be accessed by the first module; and

only allowing, by a module integrator, the first module to access a particular service provided by the second module when the first module is authorized to access the particular service according to the service authorization policy.

12. The method of claim 11, wherein the sandbox constraints include requiring that the first module does not include computer code attempting to access variables having a global scope and does not include computer code attempting to access information from outside the first module that is not directly passed to the first module.

13. The method of claim 11, further comprising:

allowing the first module to access the particular service by passing from the module integrator to the first module a pointer to an execution address of the particular service when the first module is authorized to access the service according to the service authorization policy; and

preventing the first module from accessing the particular service by passing from the module integrator to the first module an invalid pointer as the execution address of the particular service when the first module is not authorized to access the particular service according to the service authorization policy.

14. The method of claim 11, further comprising ensuring by the sandbox validator when parsing the computer code of the first module that when the first module requests access to the particular service provided by the second module that the first module correctly identifies itself with a module identifier associated with the first module.

15. The method of claim 11, further comprising:

automatically parsing by the sandbox validator each operation of the first module into one or more tokens; ensuring by the sandbox validator that a non-deterministic operation is checked with a policing function, the non-deterministic operation corresponding to an operation having at least one token listed on a non-deterministic list;

providing by the module integrator the policing function during execution of the first module to perform a runtime check of the non-deterministic operation;

## 20

allowing by the module integrator execution of the non-deterministic operation when the runtime check determines the non-deterministic operation complies with the sandbox constraints; and

preventing by the module integrator execution of the non-deterministic operation when the runtime check determines that the non-deterministic operation does not comply with the sandbox constraints.

16. The method of claim 11, further comprising automatically generating the service authorization policy by the service authorizer according to a default system-wide service authorization policy.

17. The method of claim 11, further comprising automatically generating the service authorization policy by the service authorizer according to a module-specific authorization policy and an identifier of the first module.

18. The method of claim 11, wherein the first module and the second module are written in JavaScript.

19. The method of claim 11, further comprising dynamically updating, by the service authorizer, the service authorization policy for the first module.

20. A non-transitory computer readable storage medium comprising instructions that when executed by one or more processors cause the one or more processors to perform a method of integrating a plurality of modules of computer code, the method comprising:

receiving a first module of computer code from via a communications interface;

parsing, by a sandbox validator, the computer code of the first module in order to verify that the first module complies with one or more sandbox constraints;

generating, by a service authorizer, a service authorization policy for the first module, the service authorization policy indicating which services provided by a second module of computer code are allowed to be accessed by the first module; and

only allowing, by a module integrator, the first module to access a particular service provided by the second module when the first module is authorized to access the particular service according to the service authorization policy.

\* \* \* \* \*