

US009827426B2

(12) **United States Patent**
Reddy

(10) **Patent No.:** **US 9,827,426 B2**
(45) **Date of Patent:** ***Nov. 28, 2017**

(54) **SYSTEMS AND METHODS FOR FIXATING TRANSVENOUSLY IMPLANTED MEDICAL DEVICES**

(71) Applicant: **Cardiac Pacemakers, Inc.**, St. Paul, MN (US)
(72) Inventor: **G. Shantanu Reddy**, Minneapolis, MN (US)
(73) Assignee: **Cardiac Pacemakers, Inc.**, St. Paul, MN (US)

(*) Notice: Subject to any disclaimer, the term of this patent is extended or adjusted under 35 U.S.C. 154(b) by 513 days.
This patent is subject to a terminal disclaimer.

(21) Appl. No.: **14/336,308**

(22) Filed: **Jul. 21, 2014**

(65) **Prior Publication Data**
US 2014/0336668 A1 Nov. 13, 2014

Related U.S. Application Data

(63) Continuation of application No. 13/338,924, filed on Dec. 28, 2011, now Pat. No. 8,798,770, which is a (Continued)

(51) **Int. Cl.**
A61N 1/05 (2006.01)
A61N 1/372 (2006.01)
(Continued)

(52) **U.S. Cl.**
CPC *A61N 1/37217* (2013.01); *A61N 1/056* (2013.01); *A61N 1/057* (2013.01);
(Continued)

(58) **Field of Classification Search**
CPC ... *A61N 1/37217*; *A61N 1/056*; *A61N 1/057*;
A61N 1/0573; *A61N 1/362*;
(Continued)

(56) **References Cited**
U.S. PATENT DOCUMENTS
5,000,190 A * 3/1991 Petre *A61B 5/029*
600/374
5,387,233 A 2/1995 Alferness et al.
(Continued)

FOREIGN PATENT DOCUMENTS
JP 59111748 A 6/1984
JP 08206222 A 8/1996
(Continued)

OTHER PUBLICATIONS
International Search Report and Written Opinion issued in PCT/US2008/063542, dated Aug. 21, 2008, 14 pages.

Primary Examiner — Michael Carey
(74) *Attorney, Agent, or Firm* — Seager, Tufte & Wickhem LLP

(57) **ABSTRACT**
A transvenously implantable medical device (TIMD) includes an electrical lead and a control module. The electrical lead includes one or more electrodes and is adapted for transvenous implantation. The electrical lead is also pre-biased to expand from a collapsed state to an expanded state to mechanically engage an internal wall of a blood vessel. The control module is secured to and in electrical communication with the electrical lead. The control module includes a signal management component and a power component disposed in a housing adapted for implantation into the blood vessel. The control module is adapted for at least one of stimulating and sensing a physiologic response using the one or more electrodes of the electrical lead.

12 Claims, 5 Drawing Sheets

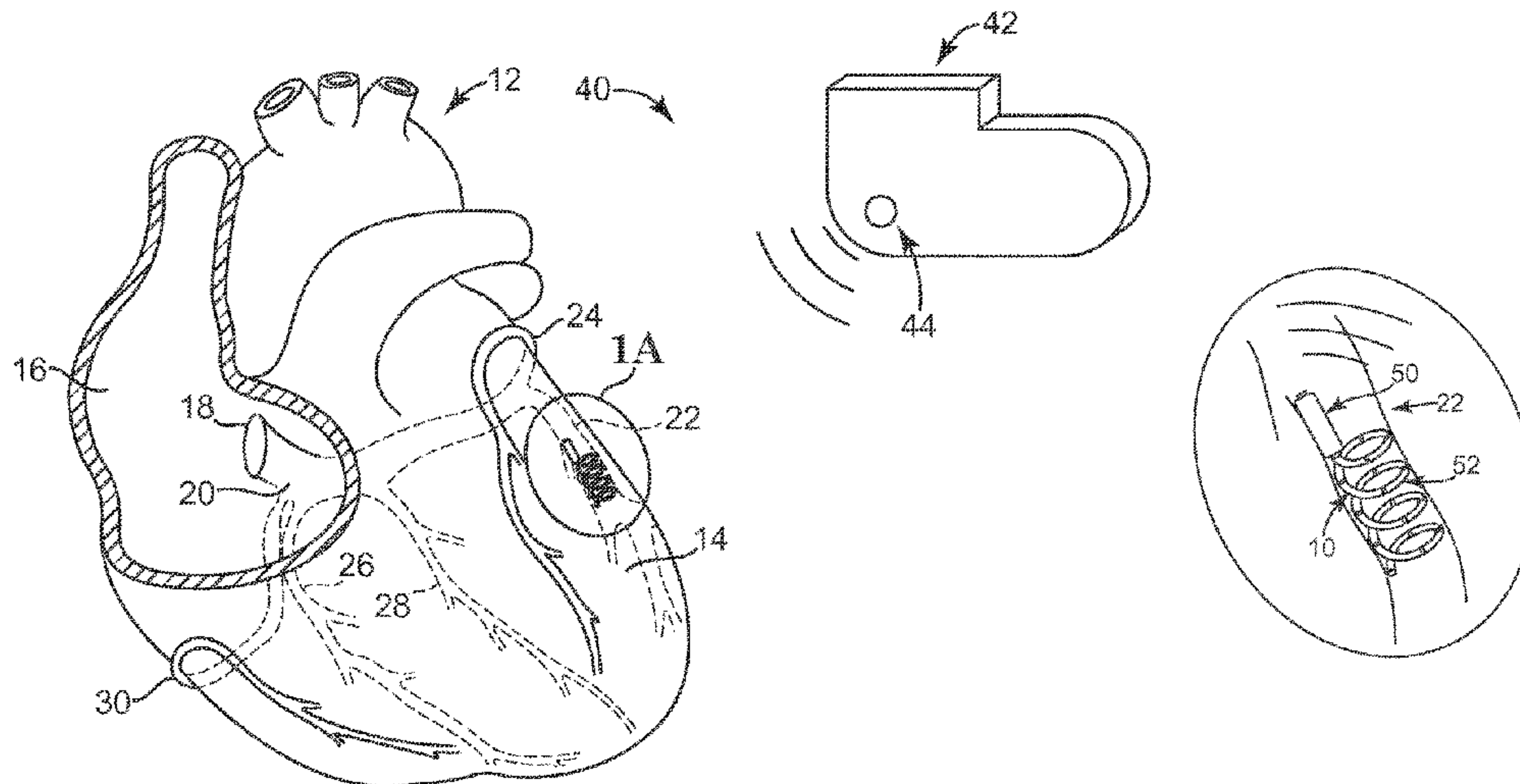

Related U.S. Application Data

continuation of application No. 11/750,185, filed on May 17, 2007, now Pat. No. 8,103,359.

(51) **Int. Cl.**

A61N 1/375 (2006.01)
A61N 1/362 (2006.01)
A61N 1/37 (2006.01)

(52) **U.S. Cl.**

CPC *A61N 1/0573* (2013.01); *A61N 1/362* (2013.01); *A61N 1/3702* (2013.01); *A61N 1/375* (2013.01); *A61N 1/3756* (2013.01); *A61N 1/37205* (2013.01); *A61N 2001/0585* (2013.01)

(58) **Field of Classification Search**

CPC *A61N 1/3702*; *A61N 1/375*; *A61N 1/3756*; *A61N 1/37205*; *A61N 2001/0585*
 USPC ... 607/122, 1, 115, 116, 119, 123, 126, 127, 607/128

See application file for complete search history.

(56)

References Cited

U.S. PATENT DOCUMENTS

5,476,498 A 12/1995 Ayers
 5,925,073 A 7/1999 Chastain et al.
 6,442,413 B1 8/2002 Silver

6,445,953 B1	9/2002	Bulkes et al.	
6,584,362 B1	6/2003	Scheiner et al.	
6,654,638 B1	11/2003	Sweeney	
6,882,887 B1	4/2005	Shelchuk et al.	
7,003,350 B2	2/2006	Denker et al.	
7,725,197 B2	5/2010	Soltis et al.	
7,747,334 B2	6/2010	Bly et al.	
8,103,359 B2 *	1/2012	Reddy	<i>A61N 1/057</i> 600/375
8,798,770 B2 *	8/2014	Reddy	<i>A61N 1/057</i> 600/375
2002/0128546 A1	9/2002	Silver	
2002/0183791 A1	12/2002	Denker et al.	
2003/0158584 A1	8/2003	Cates et al.	
2003/0236557 A1	12/2003	Whitehurst et al.	
2006/0085039 A1	4/2006	Hastings et al.	
2006/0085041 A1	4/2006	Hastings et al.	
2006/0085042 A1	4/2006	Hastings et al.	
2006/0136004 A1	6/2006	Cowan et al.	
2006/0241732 A1	10/2006	Denker et al.	
2007/0106357 A1 *	5/2007	Denker	<i>A61N 1/362</i> 607/116

FOREIGN PATENT DOCUMENTS

JP	2000350705 A	12/2000
JP	2008521554 A	6/2008
WO	WO2006045073 A1	4/2006
WO	WO2006045074 A2	4/2006
WO	WO2006045075 A1	4/2006
WO	WO2006069215 A2	6/2006

* cited by examiner

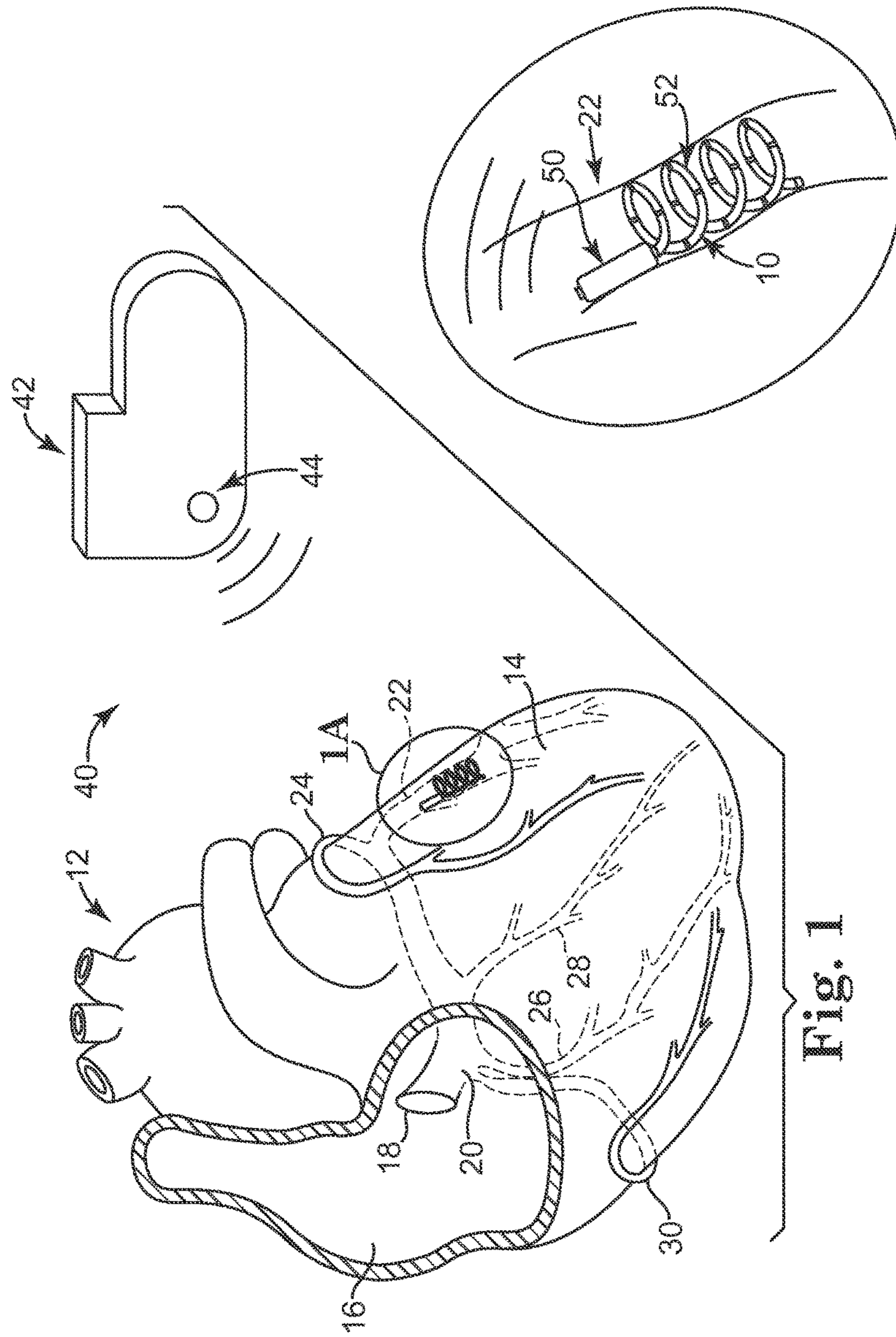

Fig. 1

Fig. 1A

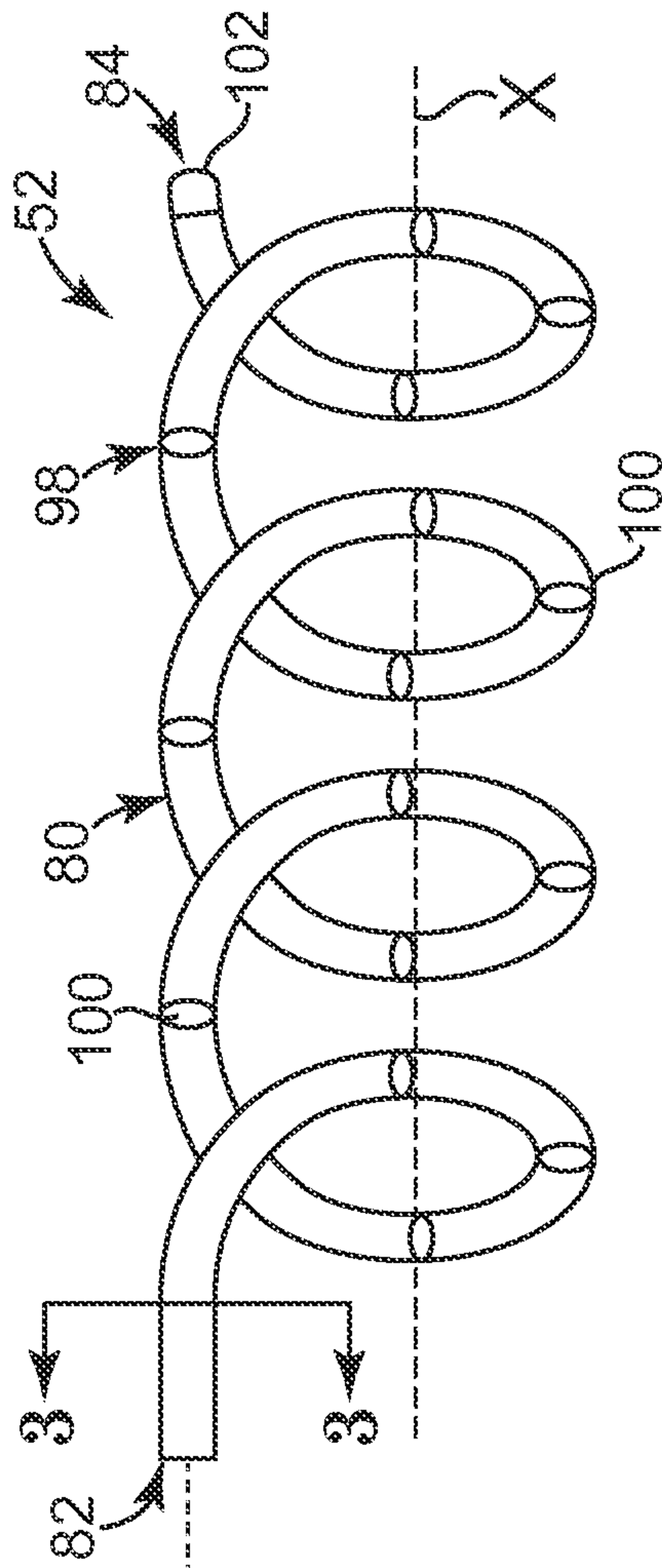
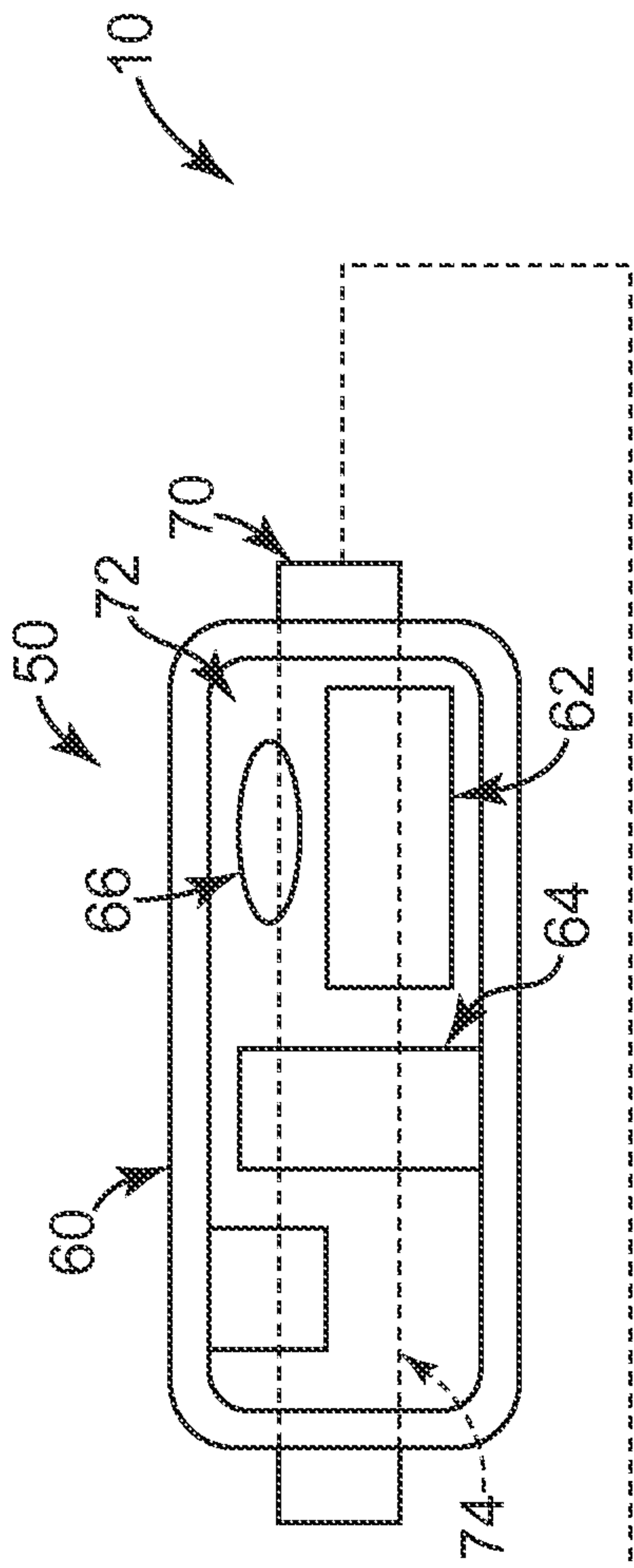

Fig. 2

Fig. 3

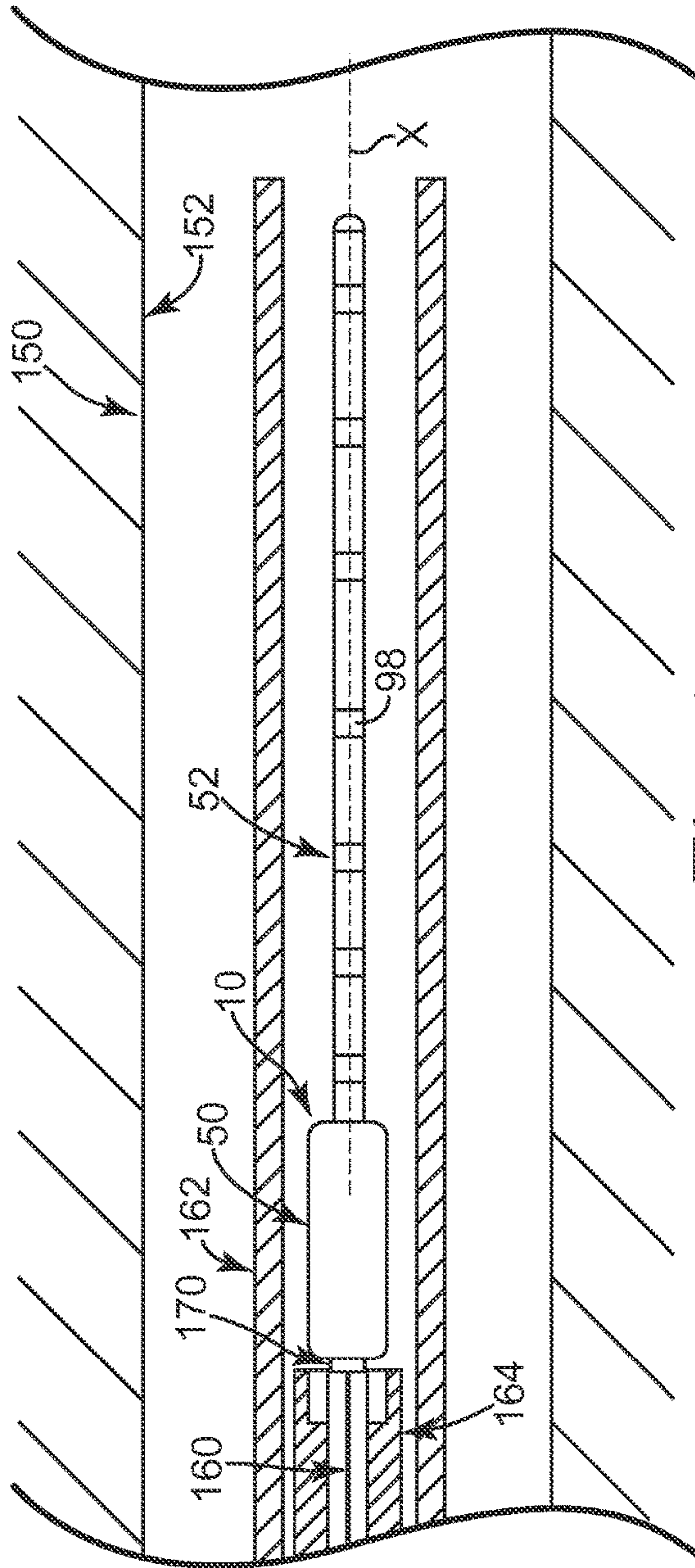

Fig. 4

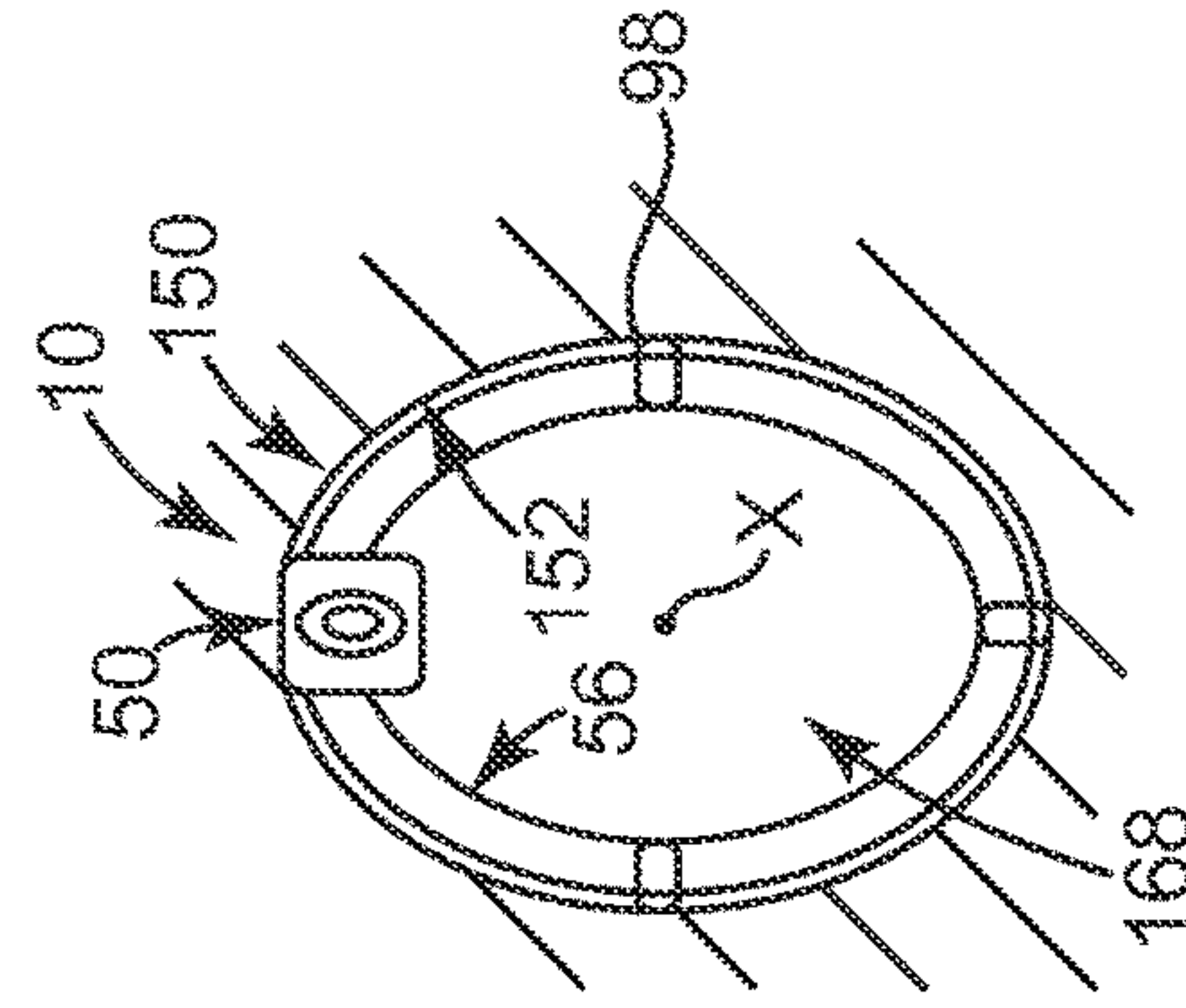

Fig. 6

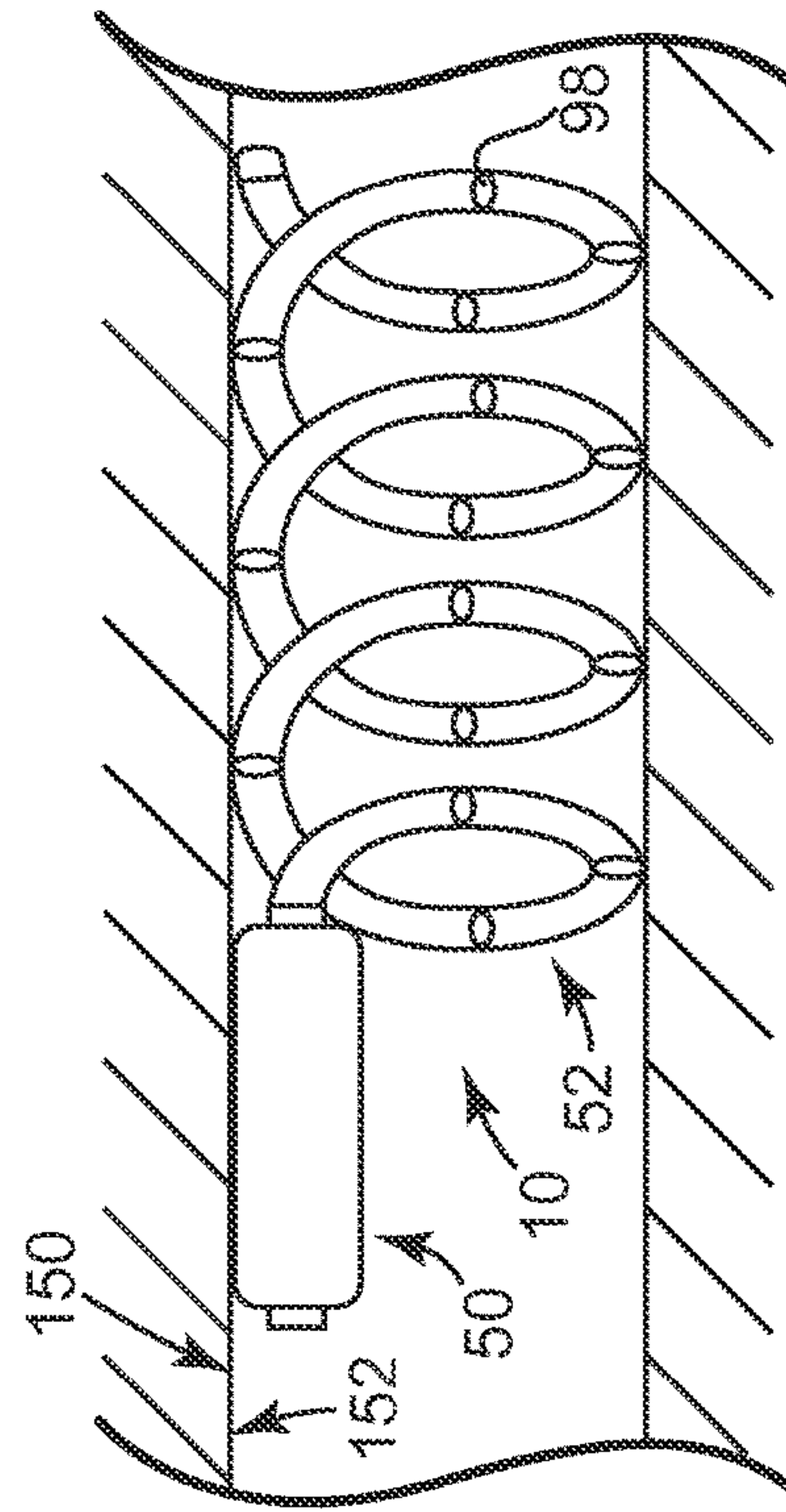

Fig. 5

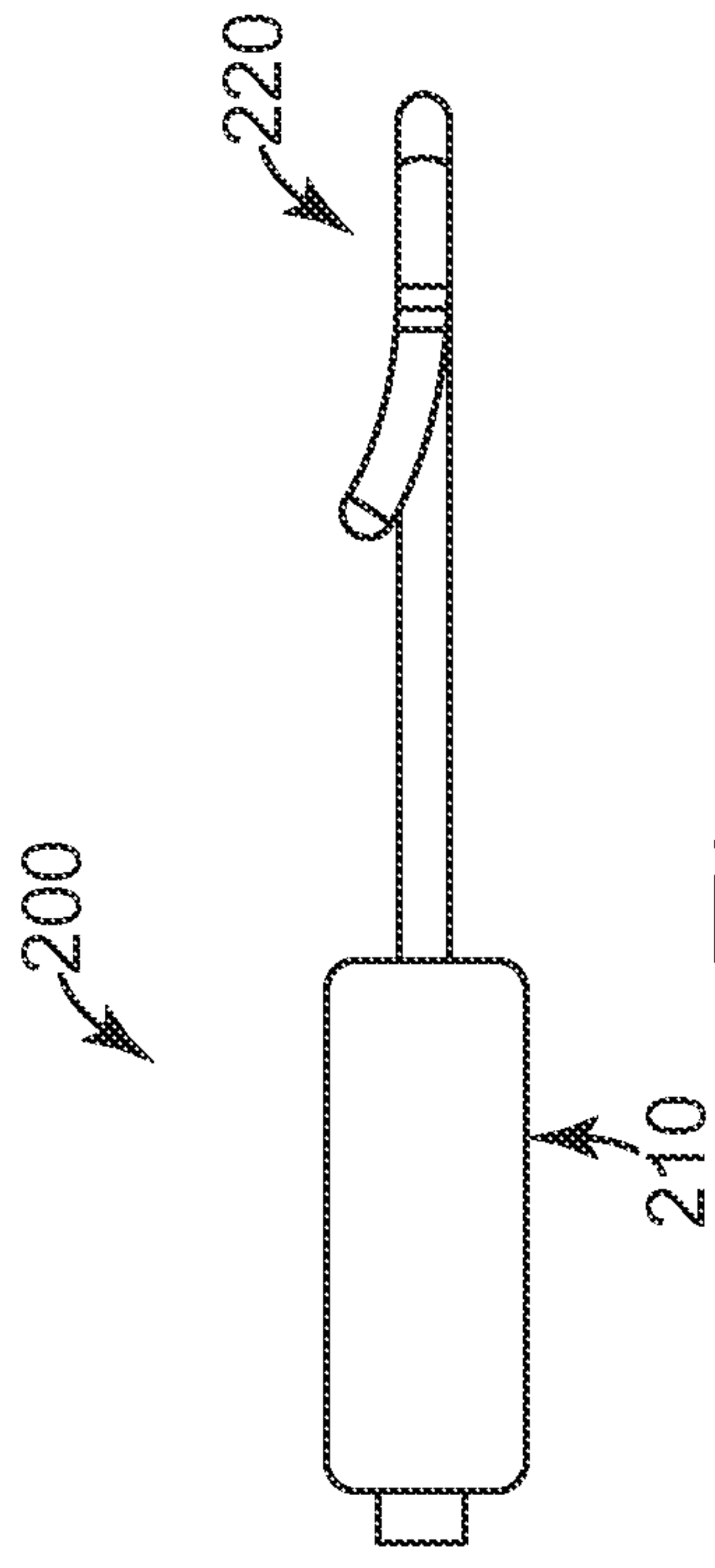

Fig. 7

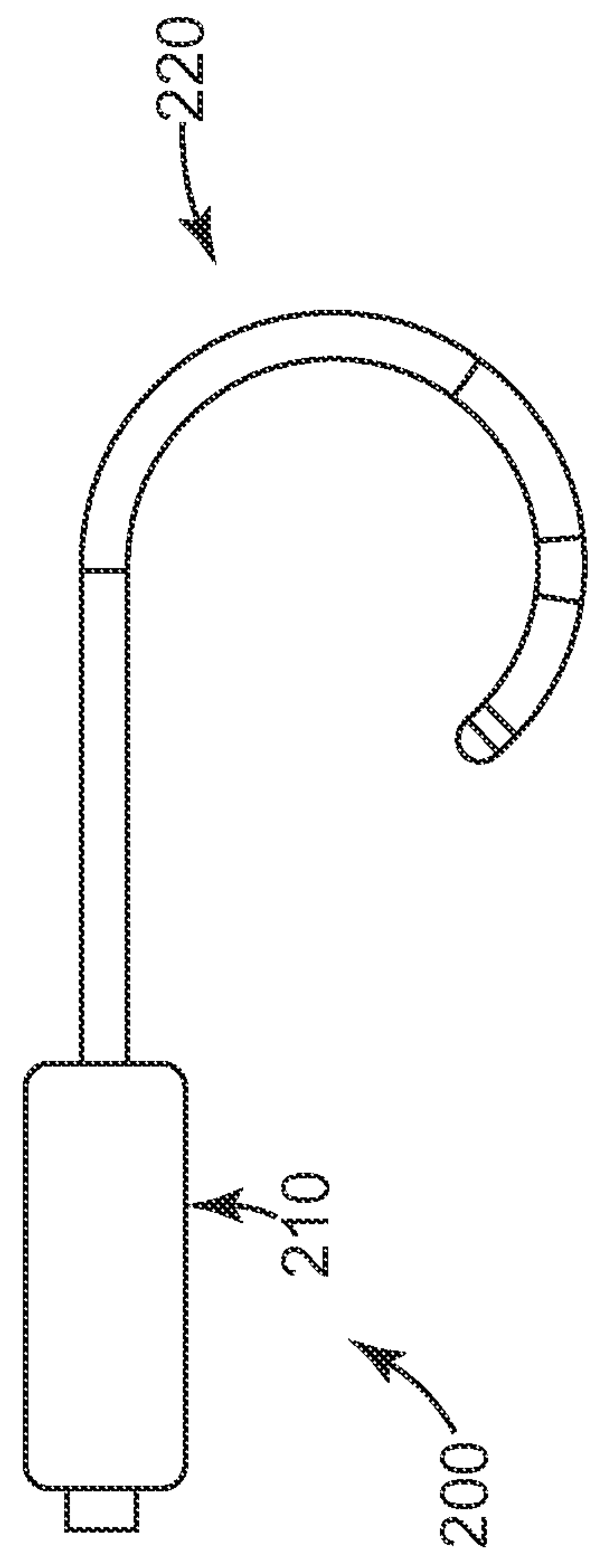

Fig. 8

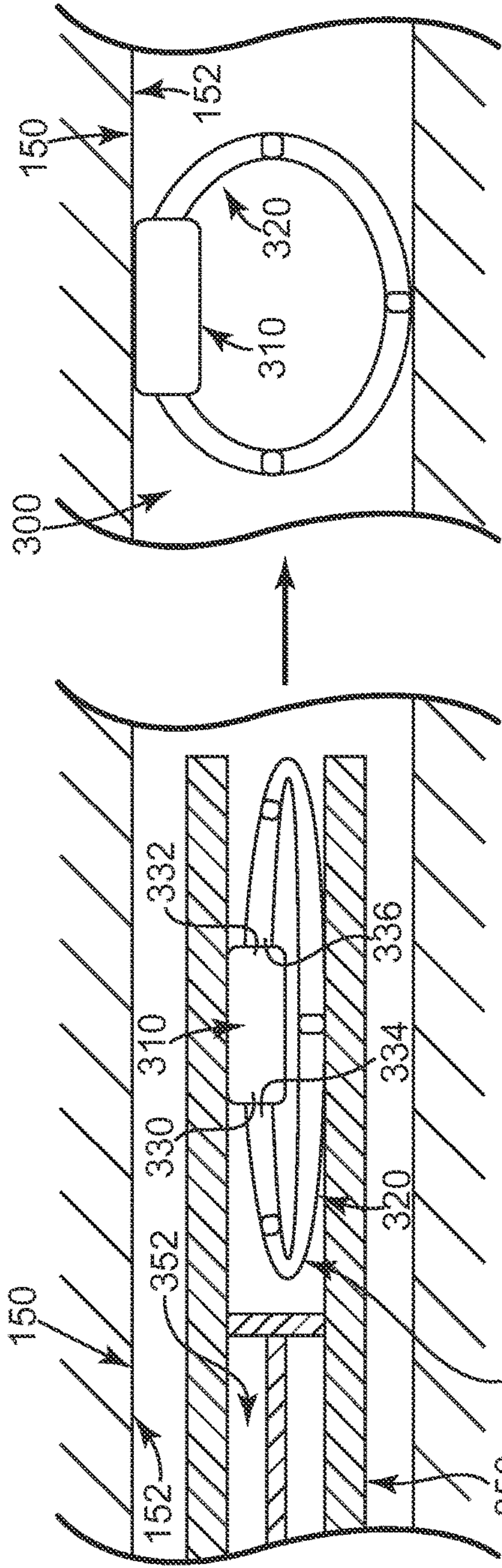

Fig. 9

Fig. 10

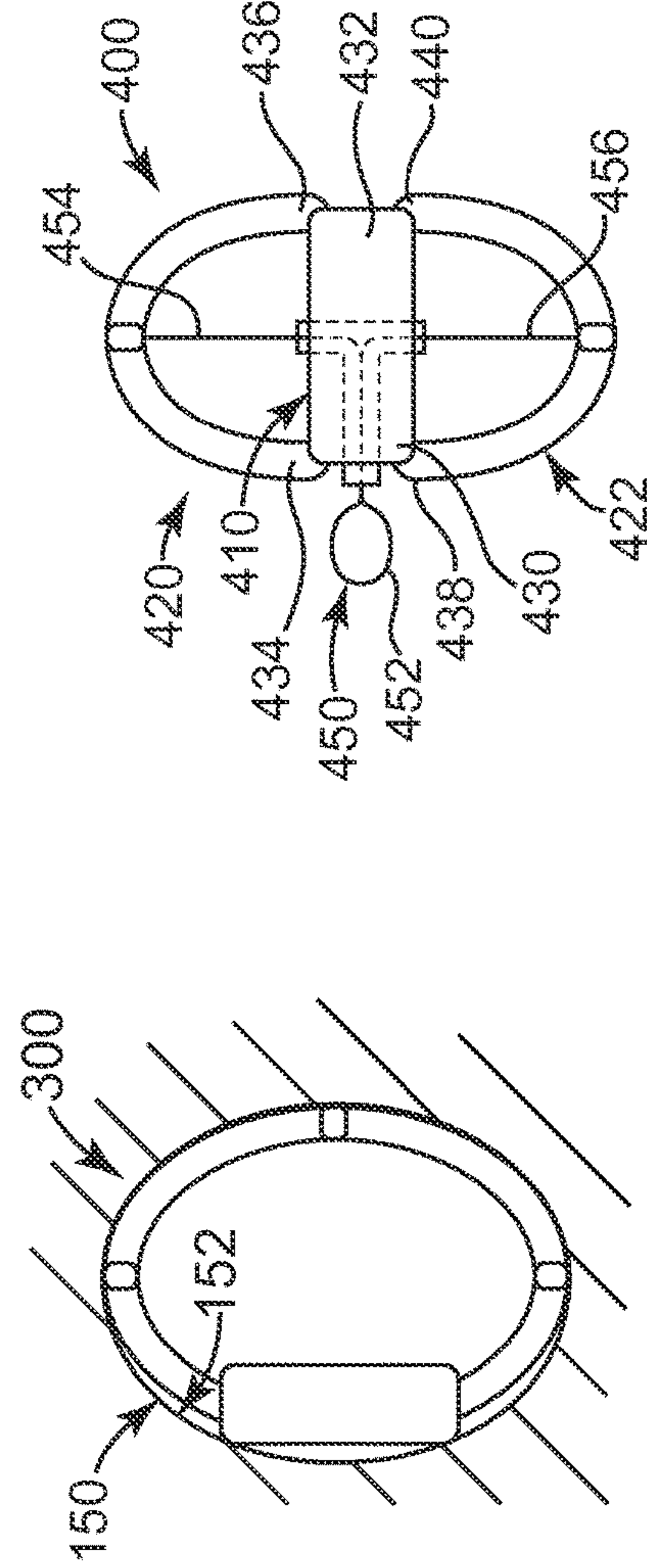

Fig. 11

Fig. 12

SYSTEMS AND METHODS FOR FIXATING TRANSVENOUSLY IMPLANTED MEDICAL DEVICES

CROSS-REFERENCE TO RELATED APPLICATIONS

This application is a continuation of U.S. application Ser. No. 13/338,924, filed Dec. 28, 2011, now U.S. Pat. No. 8,798,770, which is a continuation of U.S. application Ser. No. 11/750,185, filed May 17, 2007, now U.S. Pat. No. 8,103,359, issued Jan. 24, 2012, all of which are herein incorporated by reference in their entirety.

TECHNICAL FIELD

The present invention relates to management of physiological functions utilizing wireless implants. More specifically, the invention relates to transvenously implanting and fixating a wireless implant within vasculature of a person.

BACKGROUND

Various physiological functions can be managed utilizing minute, wireless implants that operate individually or as part of a larger system. Wireless implants can provide sensing or stimulating functionality to assist with a person's health. For example, wireless implants have been discussed in association with cardiac management, including wireless electrodes used to stimulate cardiac muscle for assisted cardiac pacing. Wireless implant configuration, deployment, and fixation within the body provide an array of both recognized and yet-to-be realized problems.

SUMMARY

One embodiment of a transvenously implantable medical device (TIMD) includes an electrical lead and a control module. The electrical lead includes one or more electrodes and is adapted for transvenous implantation. The electrical lead is also pre-biased to expand from a collapsed state to an expanded state to mechanically engage an internal wall of a blood vessel. The control module is secured to and in electrical communication with the electrical lead. The control module includes a signal management component and a power component disposed in a housing adapted for implantation into the blood vessel. The control module is adapted for at least one of stimulating and sensing a physiologic response using the one or more electrodes of the electrical lead.

One embodiment of a method of transvenous implantation includes collapsing a first lead, the first lead including an elongate lead body secured to a control module and at least one electrode in electrical communication with the control module. The control module and the first lead are transvenously implanted into a blood vessel. The first lead is expanded to engage an inner wall of the blood vessel such that the control module and the first lead are anchored in the blood vessel.

While multiple embodiments are disclosed, still other embodiments of the present invention will become apparent to those skilled in the art from the following detailed description, which shows and describes illustrative embodiments of the invention. Accordingly, the drawings and detailed description are to be regarded as illustrative in nature and not restrictive.

BRIEF DESCRIPTION OF THE DRAWINGS

FIG. 1 shows an exemplary transvenously implantable medical device (TIMD) accessing a patient's heart according to embodiments of the present invention.

FIG. 1A is an enlarged view showing the TIMD of FIG. 1 in greater detail.

FIG. 2 is a schematic of the TIMD of FIG. 1.

FIG. 3 shows a cross-section of a portion of a lead of the TIMD of FIG. 1.

FIGS. 4-6 are illustrative of an exemplary method of transvenously implanting the TIMD of FIG. 1 in a blood vessel according to embodiments of the present invention.

FIGS. 7 and 8 show another exemplary TIMD according to embodiments of the present invention.

FIGS. 9 and 10 show another exemplary TIMD and method of transvenously implanting the TIMD according to embodiments of the present invention.

FIG. 11 is illustrative of another method of transvenously implanting the TIMD of FIGS. 9 and 10 according to embodiments of the present invention.

FIG. 12 shows another exemplary TIMD according to embodiments of the present invention.

While the invention is amenable to various modifications and alternative forms, specific embodiments have been shown by way of example in the drawings and are described in detail below. The intention, however, is not to limit the invention to the particular embodiments described. On the contrary, the invention is intended to cover all modifications, equivalents, and alternatives falling within the scope of the invention as defined by the appended claims.

DETAILED DESCRIPTION

FIGS. 1 and 1A show a transvenously implantable medical device (TIMD) 10 according to embodiments of the present invention, where FIG. 1A is an enlarged view showing the TIMD 10 in greater detail. The TIMD 10 is adapted to be implanted transvenously at a desired location within the vasculature of the patient. In some embodiments, the TIMD 10 is implanted within vasculature of the heart 12 to provide cardiac sensing and/or stimulation functionality. For example, the TIMD 10 can be used to sense various physiological characteristics of the heart 12 and/or to transmit a stimulating pulse of energy to tissue of the heart 12, such as the tissue forming the left ventricle 14.

In some embodiments, the TIMD 10 is adapted to be implanted into the right atrium 16, through the coronary sinus ostium 18 and into the coronary sinus 20 of the heart 12. As is subsequently described, catheter-based implantation is contemplated in association with the TIMD 10. The TIMD 10 is implantable within the left marginal vein 22 (as shown), or any other branch vein of the coronary sinus 20, including any of those known in the art of cardiac management. For example, the TIMD 10 is optionally implanted within the great cardiac vein 24, the middle cardiac vein 26, the left posterior ventricular vein 28, the small cardiac vein 30, or others.

Although the TIMD 10 is implanted in vasculature of the heart 12 in some embodiments, the TIMD 10 can also be implanted at other intravenous locations and/or to perform other functions. For example, the TIMD 10 is optionally implanted in vasculature of the neck, such as one of the jugular veins. The TIMD 10 can perform various functions from the jugular veins, such as cardiac rhythm management via vagal nerve stimulation, for example. As another example, the TIMD 10 is optionally implanted in peripheral

vasculature and is adapted for acquiring diagnostic information, blood pressure for example, and then storing the diagnostic information, transmitting the diagnostic information to another implanted medical device (IMD), and/or transmitting the diagnostic information to an external device.

In some embodiments, the TIMD 10 is usable with a wireless electrode system 40 that includes a control system 42 having a transmitter 44 for communicating with one or more wireless electrodes, such as the TIMD 10. In one embodiment, the transmitter 44 is an inductive coil used to inductively charge the TIMD 10 with power and/or trigger delivery of stimulating energy from the TIMD 10 to the heart 12. In other embodiments, the transmitter 44 is a radiofrequency communication device, an acoustic communication device, or other device for communicating with the TIMD 10.

In some embodiments, the control system 42 directly controls stimulation via the TIMD 10 from outside of the body (externally, for example worn about the neck) or from within the body (internally, for example implanted similarly to a conventional pacemaker) using inductive communication/power transmission. The control system 42 can also use other types of communication to directly control stimulation or sensing functionality administered with the TIMD 10 in addition to or as an alternative to inductive transmission. For example, radiofrequency, optical, or acoustic communication between the TIMD 10 and the control system 42 are also contemplated. Examples of various wireless electrode systems usable in association with the TIMD 10 are described in U.S. Patent App. Pub. 2006/0085039, "Leadless Cardiac Stimulation Systems," and U.S. Patent App. Pub. 2003/0158584, "Chronically-Implanted Device for Sensing and Therapy," the entire contents of each of which are incorporated herein by reference.

In some embodiments, the control system 42 and the TIMD 10 are optionally deployed in a satellite-planet configuration, where the control system 42 acts as a planet device and the TIMD 10, or a plurality of devices similar to the TIMD 10, act as one or more satellite device(s). The TIMD 10 and control system 42 can have varying degrees of control over sensing/stimulating operation of the TIMD 10. In some embodiments, the TIMD 10 is programmed to manage cardiac stimulation for a substantial period of time. Examples of wireless, implanted electrodes that are programmable to control stimulating or sensing functionality, as well as examples of satellite-planet device configurations are described in previously-incorporated U.S. Patent App. Pub. 2003/0158584.

FIG. 2 is a schematic view of the TIMD 10 in an unassembled state. The TIMD 10 includes a control module 50 and an electrical lead 52 providing means for fixating the control module 50 within vasculature. The control module 50 includes a housing 60 and various electrical components, including a signal management component 62, a power component 64, and a communication component 66. Various components of the control module 50, including components 62, 64, 66 can be arranged as discrete devices, combined devices having shared circuits and/or processing capabilities, or according to other arrangements.

The housing 60 is adapted for transvenous delivery and implantation in human vasculature, including vasculature associated with the heart 12. The housing 60 is formed of metallic, polymeric, or other biocompatible materials. In one embodiment, the housing 60 is substantially oblong and forms a terminal connector 70 adapted to be secured to the lead 52, a hermetically sealed interior compartment 72

adapted to house and protect the components 62, 64, 66, and an inner lumen 74 (shown in dotted lines) extending longitudinally through the housing 60. The inner lumen 74 is generally adapted to facilitate implantation of the TIMD 10, as described subsequently in greater detail. In some embodiments, the housing 60 includes drug delivery features, e.g., a steroid collar, drug eluting coating, or other therapeutic agents, or others. The housing 60 also optionally includes stimulating and/or sensing features, e.g., one or more electrodes associated with the housing 60.

The signal management component 62 includes circuitry for managing operation of the TIMD 10. In some embodiments, the signal management component 62 controls delivery of stimulating energy from the TIMD 10. The signal management component 62 is optionally adapted to be programmed to execute various stimulation or sensing programs. In other embodiments, the signal management component 62 is a hardwired circuit configured to deliver set stimulation or sensing programs upon initiation by a remote controller, such as the control system 42 (FIG. 1).

The power component 64 operates to provide power to the signal management component 62 and/or the communication component 66. In various embodiments, the power component 64 is a battery, a coil for receiving a charge through inductance, or other type of power source for providing energy to the TIMD 10. In some embodiments, power is transmitted to the control module 50 from an outside source, including those internal or external to the body, such as the control system 42 (FIG. 1). If desired, the power component 64 is optionally integrated with the communication component 66 and data being transmitted to and received by the control module 50 is encoded into the power transmission as a modulation of the power signal from the control system 42. Examples of integrated power/communication arrangements are described in previously incorporated U.S. Patent App. Pub. 2003/0158584.

The communication component 66 serves to provide a communication link between the TIMD 10 and one or more other devices, such as the control system 42 (FIG. 1), that are internal and/or external to the patient. The communication component 66 includes circuitry and/or other structures for providing communication between the chronically-implanted device and another device using radio-frequency (RF) waves, acoustics, or inductance, for example. In some embodiments, the communication component 66 includes an acoustic transmitter for transmitting an acoustic signal to another device, such as the control system 42. For example, the control system 42 is optionally an implanted cardiac stimulus device, such as a pacemaker and the communication component 66 is adapted to provide bidirectional communication between the TIMD 10 and the control system 42.

The lead 52 defines a central longitudinal axis X and includes a lead body 80 extending from a terminal connector end 82 to a distal end 84. FIG. 3 shows a cross-section of a portion of the lead 52 along the line 3-3 shown in FIG. 2. As shown in FIGS. 2 and 3, the lead body 80 includes an outer, insulating sheath 88, an inner, conductive core 90, an inner, insulating sheath 92, and one or more electrodes 98. The electrodes 98 include a plurality of ring electrodes 100 disposed circumferentially about the lead body 80 and a tip electrode 102 located at the distal end 84.

The conductive core 90 is sandwiched between the outer and inner insulating sheaths 88, 92 and is optionally of a coiled design. The inner sheath 92 defines a lumen 104 that is open at the terminal connector end 82. As shown, the electrodes 98 are positioned along the lead body 80. The electrodes 98 are in electrical communication with the

conductive core **90**, providing an electrical pathway between the electrodes **98** and the control module **50**. In some embodiments, the core **90** is a coiled core, although other configurations are contemplated. For example, in other embodiments, the core **90** is a cable or ribbon conductor. The conductive core **90** can be made of any electrically conductive materials.

In some embodiments, the lead **52** includes no lumens or greater number of lumens **104**, a non-coiled conductive core **90**, or other features associated with electrical leads. For example, in some embodiments, a steroid collar is employed with the lead **52** to help ensure proper pacing and/or as a therapeutic agent, including anti-inflammatories, antithrombotics, antiproliferatives, or other types of therapeutic agents. Examples of various electrical lead features contemplated for use with the lead **52** are described in U.S. Pat. No. 6,584,362, "Leads for Pacing and/or Sensing the Heart from within the Coronary Veins," the entire contents of which are incorporated herein by reference.

The electrodes **98** can be substantially the same as known electrodes for pacing and/or defibrillation leads. The electrodes **98** are formed of an electrically conductive material such as an alloy of platinum and iridium which is highly conductive and highly resistant to corrosion. In operation, the conductive core **90** carries electrical current between the control module **50** and the electrodes **98**. As shown, the lead **52** is unipolar with a single conductor. In other embodiments, the lead **52** is bipolar where one or more of the electrodes **98** are each in electrical communication with a plurality of separate conductors (not shown).

The lead **52** is pre-biased to define a first shape in an expanded state (FIG. 2) and can be transitioned, or collapsed, to define a second shape in a collapsed state (FIG. 4). As shown in FIG. 2 and FIG. 4, the lead **52** has a substantially larger maximum outer dimension in the expanded state than in the collapsed state. In different terms, the lead **52** defines a larger profile relative to the central longitudinal axis X of the lead **52** when the lead is in the expanded state in comparison to when the lead **52** is in the collapsed state.

As shown in FIG. 2, in the expanded state, the lead **52** naturally extends through an arcuate path to define a substantially helical, or coiled shape. As will be described in greater detail, other expanded state shapes are also contemplated, including generally arcuate shapes, undulating shapes, sinusoidal shapes, circular shapes, and others. The lead **52** is pre-formed, or otherwise pre-biased to the shape exhibited in the expanded state via heat-setting, materials selection, plastic deformation of the conductive core **90**, or using another technique known in the art.

As shown in FIG. 4, the lead **52** is straighter, or more linear, in the collapsed state than in the expanded state according to some embodiments. Various collapsed state shapes are contemplated, including helical shapes having a smaller transverse profile than in the expanded state.

One manner of assembling the control module **50** to the lead **52** is described with reference to FIGS. 2, 3, and 4. In particular, the control module **50** is assembled to the lead **52** by securing the terminal connector end **82** of the lead **52** to the terminal connector **70** of the control module **50**. Upon assembly, the conductive core **90** (FIG. 3) of the lead **52** is placed in electrical communication with the components of the control module **50** such that the signal management component **62** (FIG. 2) of the module **50** can send a stimulation signal to, or receive a sensing signal from, the electrodes **98** through the conductive core **90** of the lead **52**. Additionally, the inner lumen **104** (FIG. 3) of the lead **52** is coaxially aligned to the inner lumen **74** (FIG. 2) of the

control module **50** to form a longitudinal passageway through the control module **50** into the lead **52**. In one embodiment, the lead **52** has specific biases to facilitate placement and retention of the lead **52** in the coronary sinus **20** (FIG. 1) or a branch vessel thereof.

FIGS. 4-6 are illustrative of one embodiment method of transvenously implanting the TIMD **10** in a blood vessel **150** having a vessel wall **152**. FIG. 4 shows the TIMD **10** with the lead **52** in a collapsed state. In particular, a straightening member **160**, such as a stylet or a guidewire having sufficient stiffness to straighten and maintain the lead **52** in the collapsed state, is inserted through the inner lumen **74** of the control module **50** into the lead **52** to collapse the lead **52**.

The TIMD **10** and straightening member **160** are delivered to a desired transvenous implantation site, for example in the coronary sinus **20** (FIG. 1) or a branch vein thereof. In some embodiments, the TIMD **10** and the straightening member **160** are delivered through a guide catheter **162** as shown in FIG. 4. When the guide catheter **162** is used, the TIMD **10** is deployed from the guide catheter **162** once the TIMD **10** is delivered proximate a desired location within the blood vessel **150**. In other embodiments, the TIMD **10** is delivered directly to the desired implantation site using the straightening member **160** and in the absence of the guide catheter **162** in a manner substantially similar to an over-the-wire lead delivery technique.

The straightening member **160** is then removed from the TIMD **10**. If desired, a secondary member **164** can be deployed over the straightening member **160** to press against the TIMD **10** to assist with deployment of the TIMD **10** from the guide catheter **162** and/or removal of the straightening member **160** from the TIMD **10**. In some embodiments, the secondary member **164** is catheter-like in construction and formed according to catheter-based manufacturing methods.

As the straightening member **160** is removed, the lead **52** transitions from the collapsed state to the expanded state shown in FIGS. 5 and 6 to contact the vessel wall **152**. The lead **52** provides means for anchoring or fixating the TIMD **10** in the blood vessel **150**. In particular, the maximum outer dimension of the lead **52**, for example the transverse diameter defined by the helical shape of the lead **52**, is selected such that the lead **52** will mechanically engage the vessel wall **152**. The mechanical engagement between the lead **52** and the vessel wall **152** is used to place one or more of the electrodes **98** in electrical communication with the vessel wall **152** and to anchor or otherwise fixate the TIMD **10** in position within the blood vessel **150**. In various embodiments, the lead **52** includes coatings, e.g., fibrosis encouraging coatings, or surface features to enhance frictional engagement with the vessel wall **152**. In other embodiments, the lead **52** includes anti-fibrosis coatings or treatments to discourage fibrosis and facilitate lead extraction. As shown in FIG. 6, upon expansion the TIMD **10** defines a central passage **168** through the expanded shape of the TIMD **10**. In some embodiments, the central passage **168** facilitates blood flow past the TIMD **10**.

Once disposed within the blood vessel **150**, the TIMD **10** is used for sensing or stimulation according to various embodiments. For example, the blood vessel **150** is optionally the coronary sinus **20** (FIG. 1) or one of the branch vessels thereof. The electrodes **98** of the TIMD **10** can then be used to transmit a pulse of stimulating energy through the vessel wall **152** to surrounding tissue of the heart **12**.

According to some methods of transvenous implantation, the TIMD **10** is re-collapsible following transvenous implantation to remove or reposition the TIMD **10**. For example, the secondary member **164** can be used to grip the

control module **50** following implantation of the TIMD **10**. In some embodiments, a vacuum is applied through the secondary member **164**, which secures the control module **50** to the secondary member **164**. The control module **50** optionally includes a proximal seal **170** that is able to be engaged by the secondary member **164**. In one embodiment, the proximal seal **170** facilitates coupling of the control module **50** to the secondary member **164** via application of negative pressure through the secondary member **164** by forming a better seal between the control module **50** and the secondary member **164**.

In other embodiments, the secondary member **164** includes gripping elements (not shown), somewhat like jaws of a pliers, for gripping the control module **50** or associated structures. In still other embodiments, the control module **50** includes a wire loop (not shown) and the secondary member **164** includes a hook (not shown) for grasping the loop. Other means for securing the control module **50** relative to the secondary member **164** are also contemplated, including detents, magnets, adhesives, male and female threads, and others.

Once the secondary member **164** is secured to the control module **50**, the straightening member **160** is reinserted into the lumen **104** of the lead **52** through the inner lumen **74** of the control module **50**. As the straightening member **160** is reintroduced into the lead **52**, the lead **52** transitions to the collapsed state, and out of mechanical engagement with the vessel wall **152**. Once the lead **52** has been partially or fully collapsed, the TIMD **10** is able to be removed or repositioned as desired.

FIGS. **7** and **8** show another TIMD **200** according to some embodiments of the invention. The TIMD **200** includes a control module **210** and an electrical lead **220** providing means for fixating the control module **210** within vasculature. In some embodiments, the control module **210** and the lead **220** include substantially similar components as the control module **50** and the lead **52** of the TIMD **10**. The lead **220** extends through an arcuate path and is curved or biased, being adapted to expand from a collapsed state (not shown), for example substantially straight, to an expanded state, for example having the curvatures shown in FIGS. **7** and **8**. Similarly to the TIMD **10**, the lead **220** of the TIMD **200** defines a substantially larger maximum outer dimension in the expanded state than in the collapsed state.

As shown in FIG. **7**, the curvature of the lead **220** is primarily in two dimensions, or within a single plane. As shown in FIG. **8**, the curvature of lead **220** also includes a non-planar component, with a second bend or curve in a second plane. The lead **220** is pre-formed, or otherwise pre-biased to the expanded state via heat-setting, materials selection, plastic deformation, or others. In some embodiments, the lead **220** is constructed and arranged for fixation in the coronary sinus **20**, and is pre-biased to facilitate placement and retention in the coronary sinus **20**, or a branch vessel thereof. Various examples of structures and methods for providing such pre-biased, curved shapes are described in co-pending U.S. patent application Ser. No. 11/277,326, filed Mar. 23, 2006, and entitled "Left Ventricular Lead Shapes," the entire contents of which are incorporated herein by reference.

In some embodiments, the TIMD **200** is transvenously implanted in a similar manner to the TIMD **10**, for example using the guide catheter **162** (FIG. **4**), the secondary member **164** (FIG. **4**), and/or the straightening member **160** (FIG. **4**) as previously described. Once implanted, the lead **220** is transitioned from the collapsed state to the expanded state to contact the vessel wall **152** (FIG. **4**). The maximum outer

dimension of the lead **220**, for example the outer diameter defined by the arcuate shape of the lead **52**, is selected such that the lead **52** will mechanically engage the vessel wall **152** to anchor the TIMD **200** in the blood vessel **150**. The TIMD **200** can also be removed from the blood vessel **150** in a similar manner to that described in association with the TIMD **10** according to some embodiments.

FIGS. **9** and **10** show another TIMD **300** according to some embodiments of the invention and are illustrative of one method of transvenously implanting the TIMD **300**. The TIMD **300** includes a control module **310** and an electrical lead **320** providing means for fixating the control module **310** within vasculature. The lead **320** is adapted to transition between a collapsed state and an expanded state. In some embodiments, the control module **310** and the lead **320** include substantially similar components as the control module **50** and the lead **52** of the TIMD **10**. The control module **310** optionally includes one or more electrodes **315** for performing sensing and/or stimulating functions similar to those previously described. In some embodiments, the electrode **315** is used in conjunction with one or more electrodes of the lead **320**.

As shown in FIGS. **9** and **10**, the control module **310** has a proximal end **330** and distal end **332** and the lead **320** has a first end **334** and a second end **336**. The first end **334** of the lead **320** is secured to the proximal end **330** of the control module **310** while the second end **336** of the lead **320** is secured to the distal end **332** of the control module **310**. The lead **320** extends through an arcuate shape from the proximal end **330** to the distal end **332** of the control module **310**.

FIG. **9** shows the lead **320** in the collapsed state, where the lead **320** has been pressed into a more compact, linear shape than in the expanded state (FIG. **10**). FIG. **10** shows the lead **320** in the expanded state, where the lead **320** defines a greater height, or outer diameter in the expanded state than in the collapsed state. In different terms, in the expanded state the lead **320** has a substantially larger maximum outer dimension than in the collapsed state. The lead **320** is pre-formed, or otherwise pre-biased to the shape exhibited in the expanded state via heat-setting, materials selection, plastic deformation to impart a curvature, or others.

One method of transvenously implanting the TIMD **300** is also generally illustrated in FIGS. **9** and **10**. As shown in FIG. **9**, the lead **320** is maintained in the collapsed state within a catheter **350**. The catheter **350** is guided to a desired position within the blood vessel **150**. Once the TIMD **300** is positioned proximate to the desired position for implantation, a pusher **352** is used to eject the TIMD **300** from the catheter **350**. Once the external force of the catheter **350** is removed from the TIMD **300**, the TIMD **300** transitions to the expanded state as shown in FIG. **10** to engage the vessel wall **152** and anchor the TIMD **300** in place. Although the TIMD **300** is shown oriented "sideways" within the blood vessel **150**, other orientations are also contemplated. For example, the TIMD **300** is optionally transvenously implanted as shown in FIG. **11**, where the TIMD **300** is oriented substantially coaxially with the blood vessel **150**.

FIG. **12** shows another exemplary TIMD **400** according to embodiments of the present invention. The TIMD **400** includes a control module **410**, a first electrical lead **420**, and a second electrical lead **422**, the first and second leads **420**, **422** providing means for fixating the control module **410** within vasculature. The first and second leads **420**, **422** are adapted to transition between a collapsed state and an expanded state. In some embodiments, the control module

410 and the leads 420, 422 generally include substantially similar components as the control module 50 and the lead 52 of the TIMD 10 (FIG. 1).

As shown in FIG. 12, the control module 410 has a proximal end 430 and distal end 432. The first lead 420 has a first end 434 and a second end 436. The second lead 422 has a first end 438 and a second end 440. The first ends 434, 438 of the leads 420, 422 are secured to the proximal end 430 of the control module 410 while the second ends 436, 440 of the leads 420, 422 are secured to the distal end 432 of the control module 410. The first and second leads 420, 422 extend through opposing, arcuate paths relative to the control module 410 to define a pair of semi-circular shapes.

The leads 420, 422 are transitionable between an expanded state and a more compact, collapsed state. FIG. 12 shows the leads 420, 422 in the expanded state. As described in association with other embodiments, the leads 420, 422 are pre-biased to the expanded state such that they will expand outwardly to the shape shown generally in FIG. 12. The leads 420, 422 are sufficiently flexible to be compressed to a collapsed state where the leads 420, 422 define a more linear, compact shape. In particular, the leads 420, 422 are pressed inwardly toward the control module 410 in the collapsed state. As described in association with other embodiments, the leads 420, 422 define a greater height, or overall outer diameter in the expanded state than in the collapsed state. The leads 420, 422 are pre-biased to the expanded state shape via heat-setting, materials selection, plastic deformation, or others.

The TIMD 400 can also include means for transitioning the TIMD 400 to the collapsed state. In some embodiments, the TIMD 400 includes a filament 450 that can be tensioned to collapse the first and second leads 420, 422 toward the control module 410. The filament 450 includes a loop 452 at the proximal end 430 of the control module 410. The filament 450 extends from the loop 452 through the control module 410 and splits into a first leg 454 and a second leg 456. The first leg 454 is secured to the first lead 420 while the second leg 456 is secured to the second lead 422. In operation, the loop 452 is pulled, which in turn tensions the first and second legs 454, 456, collapsing the leads 420, 422.

The TIMD 400 is transvenously implanted in a similar manner as that described in association with the TIMD 300. For example, the catheter 350 is optionally used to maintain the TIMD 400 in the collapsed state. The pusher 352 is then optionally used to eject the TIMD 400 from the catheter 350. Once the external force of the catheter 350 is removed from the TIMD 400, the TIMD 400 transitions to the expanded state as shown in FIG. 12 to engage the vessel wall 152 and anchor the TIMD 400 in place.

In some embodiments, the TIMD 400 is removed from the blood vessel 150 (FIG. 10) by fully or partially collapsing the leads 420, 422 toward the control module 410 using the filament 450. For example, a catheter or other device (not shown) having gripping jaws or a hook is used to pull the filament 450 by hooking, or grasping the loop 452 and pulling on the loop 452. Upon tensioning the filament 450, the TIMD 400 is transitioned to the collapsed state and is repositioned as desired or removed entirely from the blood vessel 150. The various TIMD embodiments previously described can also include a filament forming a loop similar to the filament 450 and loop 452 to provide means for grasping and/or collapsing the TIMDs associated with those embodiments.

Various modifications and additions can be made to the exemplary embodiments discussed without departing from the scope of the present invention. For example, while the

embodiments described above refer to particular features, the scope of this invention also includes embodiments having different combinations of features and embodiments that do not include all of the described features. Accordingly, the scope of the present invention is intended to embrace all such alternatives, modifications, and variations as fall within the scope of the claims, together with all equivalents thereof.

What is claimed is:

1. An implantable medical device system comprising:

a straightening member adapted for facilitating delivery of an implantable medical device into a vein of the coronary sinus of a heart;

the implantable medical device comprising:

a power component disposed within a housing adapted for implantation in the vein of the coronary sinus of the heart;

a conductor adapted for implantation in the vein, secured to and in electrical communication with the power component and extending distally from the power component;

a plurality of electrodes coupled to the conductor such that each electrode is in electrical connection with the conductor;

an elongate member disposed about the conductor and including a lumen configured to receive the straightening member, wherein at least a portion of the elongate member is configured to transition from an arcuate, expanded shape to a non-arcuate, non-expanded shape when the straightening member is inserted in the lumen of the elongated member in order to facilitate delivery of the implantable medical device into the vein of the coronary sinus of the heart, and to transition from the non-arcuate, non-expanded shape to the arcuate, expanded shape when the straightening member is withdrawn from the lumen of the elongated member in order to facilitate anchoring of the implantable medical device within the vein of the coronary sinus of the heart after delivery.

2. The implantable medical device system of claim 1, wherein the arcuate, expanded shape of the elongate member is a helical shape.

3. The implantable medical device system of claim 1, wherein the arcuate, expanded shape of the elongate member is a coiled shape.

4. The implantable medical device system of claim 1, wherein the arcuate, expanded shape of the elongate member is one of an undulating shape, a sinusoidal shape and a circular shape.

5. The implantable medical device system of claim 1, wherein the elongate member is adapted to form the arcuate expanded shape within the vein such that one or more of the plurality of electrodes are placed in electrical communication with a wall of the vein.

6. The implantable medical device system of claim 1, wherein the plurality of electrodes includes a tip electrode.

7. The implantable medical device system of claim 1, wherein the straightening member is configured to straighten and maintain the elongate member in the non-expanded shape while the straightening member remains within the lumen of the elongated member.

8. A method for delivering an implantable medical device, wherein the implantable medical device includes a power component disposed within a housing configured for implantation in a vein of a patient, a conductor configured for implantation in the vein of the patient and secured to and in electrical communication with the power component and

11

extending distally from the power component, a plurality of electrodes coupled to the conductor such that each electrode is in electrical connection with the conductor, and an elongate member disposed about the conductor and including a lumen, wherein at least a portion of the elongate member is configured to transition between an arcuate, expanded shape and a non-arcuate, non-expanded shape, the method comprising:

with a straightening member inserted in the lumen of the elongated member to maintain the elongate member in the non-arcuate, non-expanded shape, positioning the power component, the elongated member and the conductor within a vein of a coronary sinus of a heart; a; and

withdrawing the straightening member from the lumen of the elongated member to transition the elongated member from the non-arcuate, non-expanded shape to the arcuate, expanded shape to facilitate anchoring of the implantable medical device within the vein with one or more of the plurality of electrodes placed in electrical contact with a wall of the vein.

12

9. The method of claim **8**, further comprising inserting the straightening member into the lumen of the elongated member before positioning the power component, the elongated member and the conductor within the vein of the coronary sinus of the heart.

10. The method of claim **8**, wherein withdrawing the straightening member comprises proximally moving the straightening member relative to the elongated member.

11. The method of claim **8**, further comprising using a secondary member to press against the implantable medical device while the straightening member is withdrawn from the lumen of the elongated member.

12. The method of claim **8**, wherein positioning the power component, the elongated member and the conductor within the vein of the coronary sinus of the heart comprises deploying together the power component, the elongated member, the conductor and the straightening member from a distal end of a guide catheter.

* * * * *