



US009826944B2

(12) **United States Patent**
Kobayashi

(10) **Patent No.:** **US 9,826,944 B2**
(45) **Date of Patent:** **Nov. 28, 2017**

(54) **RADIATION DETECTOR AND X-RAY CT APPARATUS PROVIDED THEREWITH**

(71) Applicant: **Hitachi, LTD.**, Tokyo (JP)
(72) Inventor: **Hiroyuki Kobayashi**, Tokyo (JP)
(73) Assignee: **HITACHI, LTD.**, Tokyo (JP)

(*) Notice: Subject to any disclaimer, the term of this patent is extended or adjusted under 35 U.S.C. 154(b) by 4 days.

(21) Appl. No.: **14/773,562**

(22) PCT Filed: **Mar. 4, 2014**

(86) PCT No.: **PCT/JP2014/055347**

§ 371 (c)(1),

(2) Date: **Sep. 8, 2015**

(87) PCT Pub. No.: **WO2014/136734**

PCT Pub. Date: **Sep. 12, 2014**

(65) **Prior Publication Data**

US 2016/0015334 A1 Jan. 21, 2016

(30) **Foreign Application Priority Data**

Mar. 7, 2013 (JP) 2013-045147

(51) **Int. Cl.**

A61B 6/03 (2006.01)

A61B 6/06 (2006.01)

(Continued)

(52) **U.S. Cl.**

CPC **A61B 6/06** (2013.01); **A61B 6/032** (2013.01); **A61B 6/4233** (2013.01);

(Continued)

(58) **Field of Classification Search**

CPC A61B 6/03; A61B 6/032; A61B 6/035; A61B 6/4233; A61B 6/4291; G01T 1/20;

(Continued)

(56) **References Cited**

U.S. PATENT DOCUMENTS

4,560,877 A * 12/1985 Hoffman G01T 1/2018
250/366

5,965,893 A * 10/1999 Tonami G01T 1/1648
250/370.11

(Continued)

FOREIGN PATENT DOCUMENTS

JP 2004-151007 A 5/2004
JP 2008-168110 A 7/2008
JP 2010-223837 A 10/2010

Primary Examiner — Thomas R Artman

(57) **ABSTRACT**

An X-ray detector and an X-ray CT apparatus that facilitate collimator plate arrangement are characterized by comprising radiation detection element arrays in which a plurality of radiation detection elements detecting a radiation generated from a radiation source are arranged in a first direction and a second direction orthogonal to the first direction, collimator plates that are arranged along the first direction on the radiation source side of the radiation detection element arrays to remove scattered radiations, and collimator plate support members that have grooves supporting the collimator plate and are arranged along the second direction between the radiation detection elements.

6 Claims, 9 Drawing Sheets

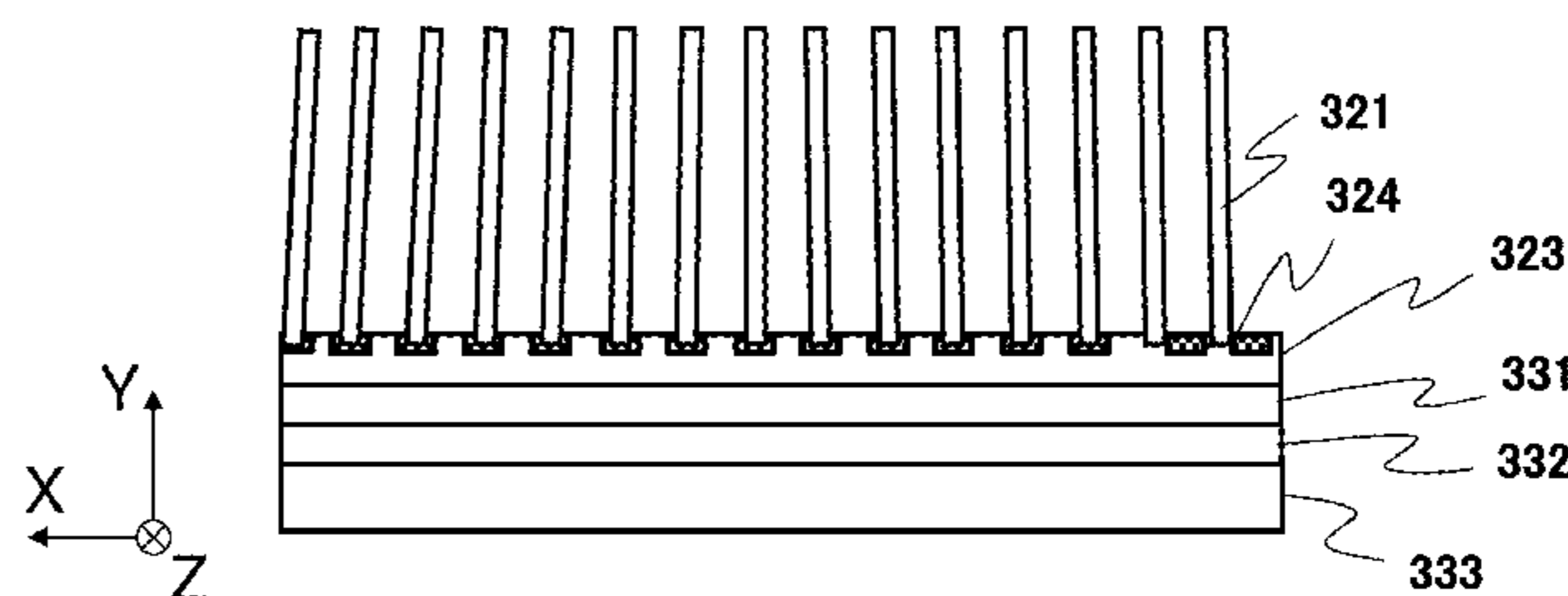
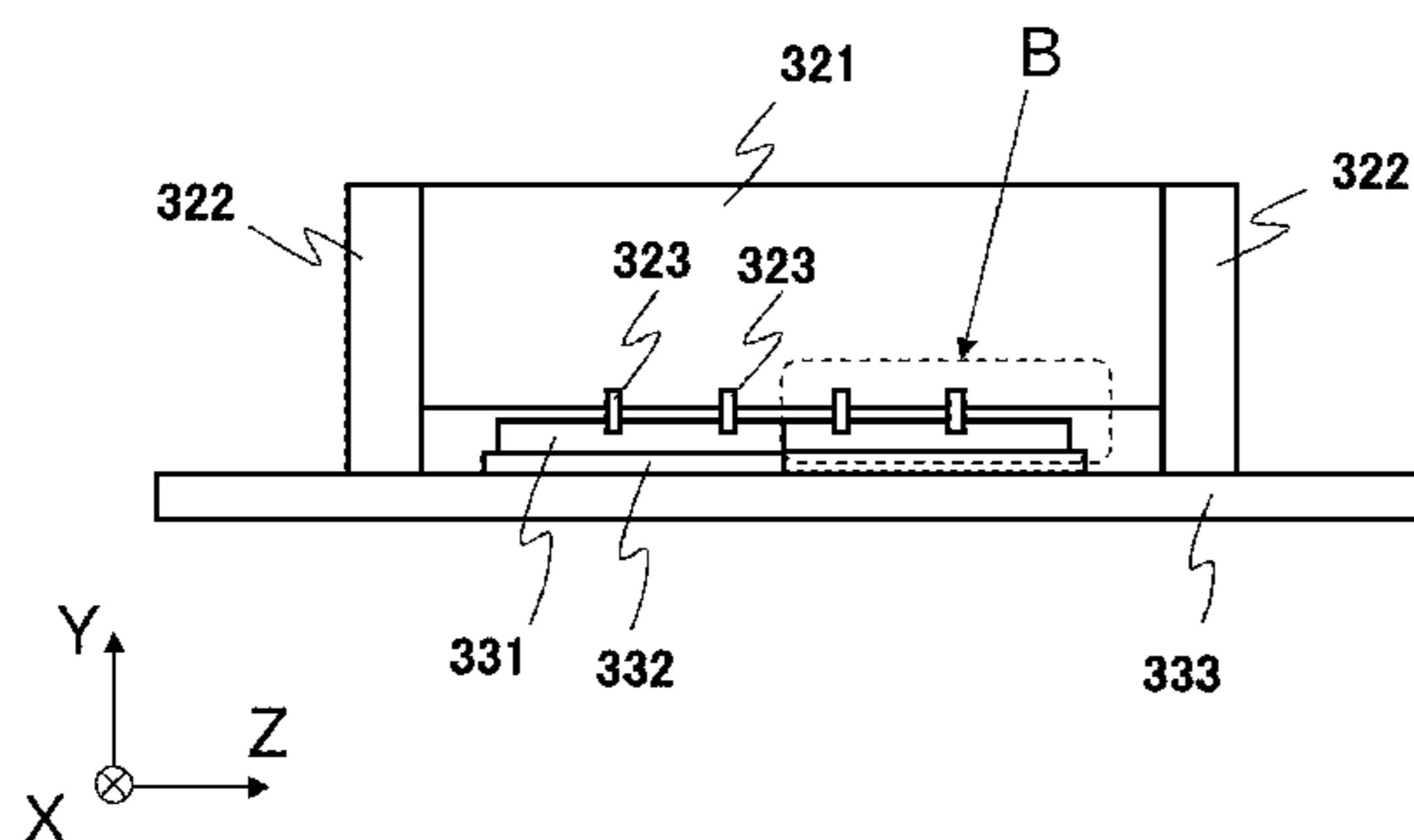

US 9,826,944 B2

Page 2

(51)	Int. Cl.		6,181,767	B1 *	1/2001	Harootian	A61B 6/4291		
	<i>A61B 6/00</i>	(2006.01)						378/154		
	<i>G01T 1/29</i>	(2006.01)	6,587,538	B2 *	7/2003	Igarashi	A61B 6/06		
	<i>G21K 1/02</i>	(2006.01)						250/367		
(52)	U.S. Cl.		7,356,124	B2 *	4/2008	Freund	G01N 23/046		
	CPC	8,817,946	B2 *	8/2014	Kobayashi	A61B 6/032		
		<i>A61B 6/4266</i> (2013.01); <i>A61B 6/4291</i>						250/366		
		(2013.01); <i>A61B 6/4435</i> (2013.01); <i>A61B</i>	8,873,705	B2 *	10/2014	Konno	A61B 6/032		
		<i>6/461</i> (2013.01); <i>G01T 1/2985</i> (2013.01);						378/19		
		<i>A61B 6/5205</i> (2013.01); <i>G21K 1/025</i>	2002/0064252	A1 *	5/2002	Igarashi	A61B 6/06		
		(2013.01)						378/19		
(58)	Field of Classification Search		2006/0291617	A1 *	12/2006	Freund	G01N 23/046		
	CPC ...	G01T 1/2002; G01T 1/2006; G01T 1/2018;						378/19		
		G01T 1/24; G01T 1/244; G01T 1/2928;	2008/0101542	A1 *	5/2008	Ikhlef	G21K 1/025		
		G01T 1/2971; G21K 1/02; G21K 1/025;						378/147		
		G01N 23/046	2011/0129069	A1 *	6/2011	Freund	G21K 1/025		
	See application file for complete search history.							378/147		
			2012/0093280	A1 *	4/2012	Konno	A61B 6/032		
(56)	References Cited							378/7		
	U.S. PATENT DOCUMENTS		2014/0158543	A1 *	6/2014	Chen	C25D 1/02		
								205/50		
	5,991,357 A *	11/1999	Marcovici	2016/0015334	A1 *	1/2016	Kobayashi	A61B 6/06
										378/4

* cited by examiner

FIG. 1

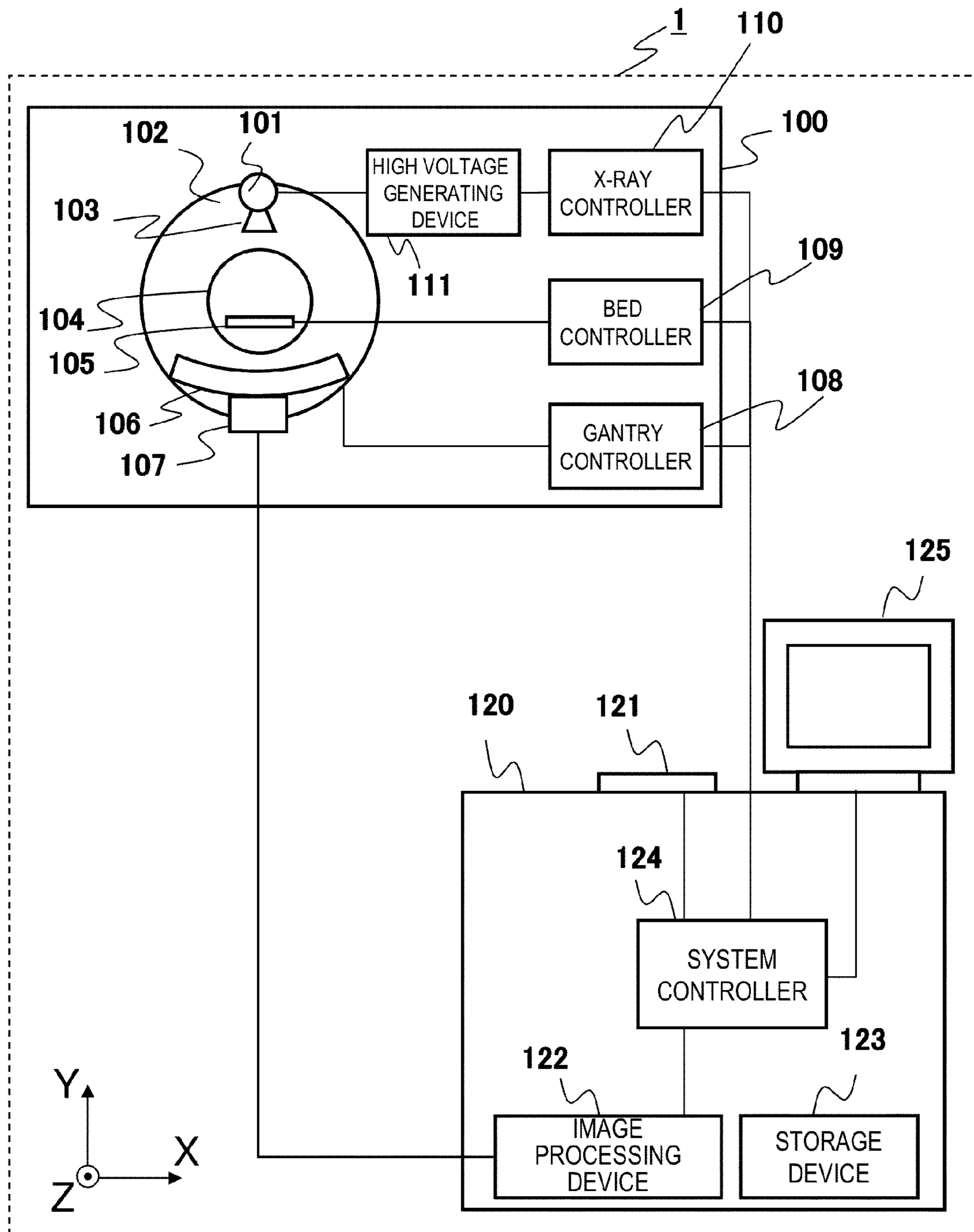

FIG. 2

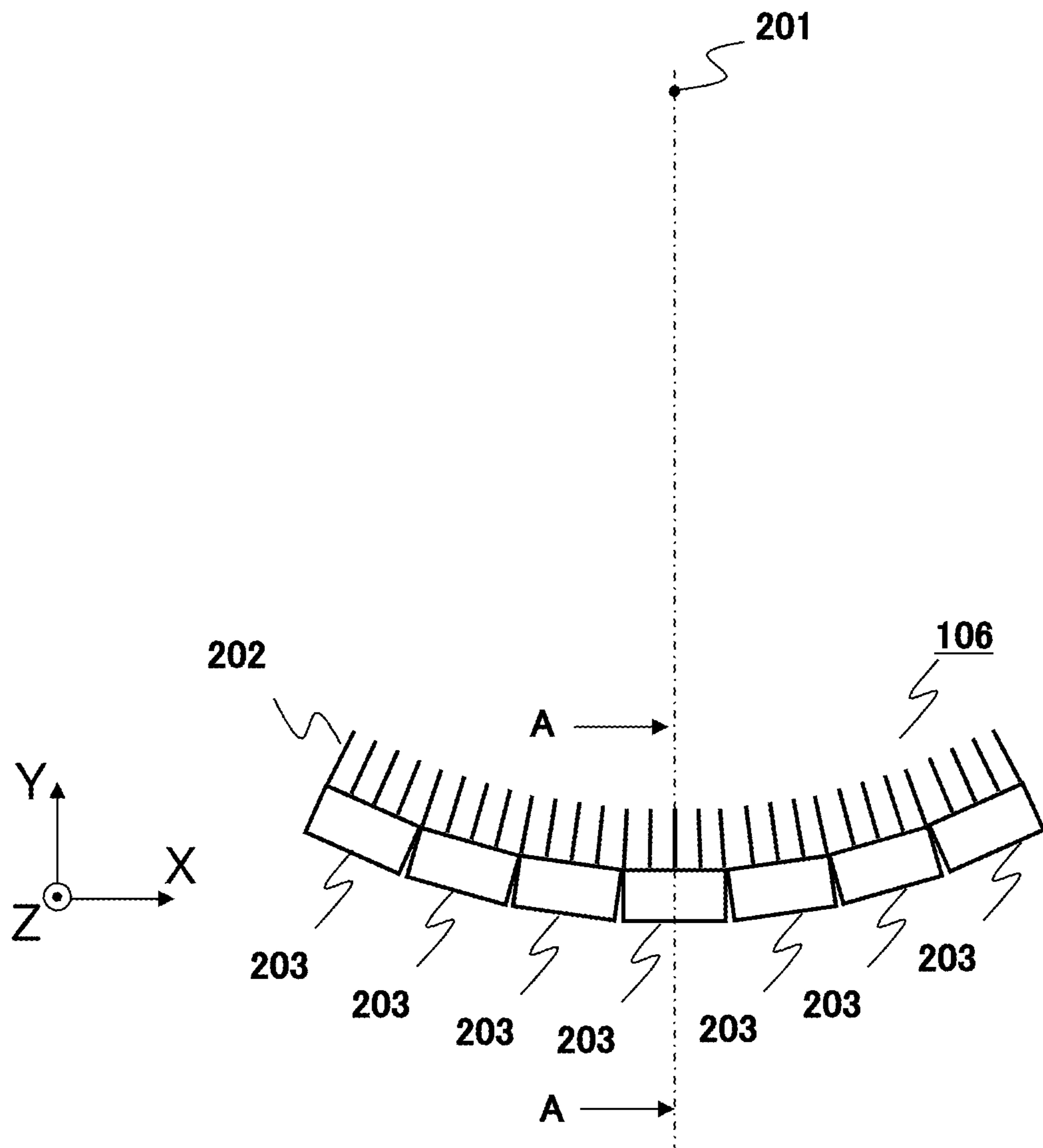

FIG. 3

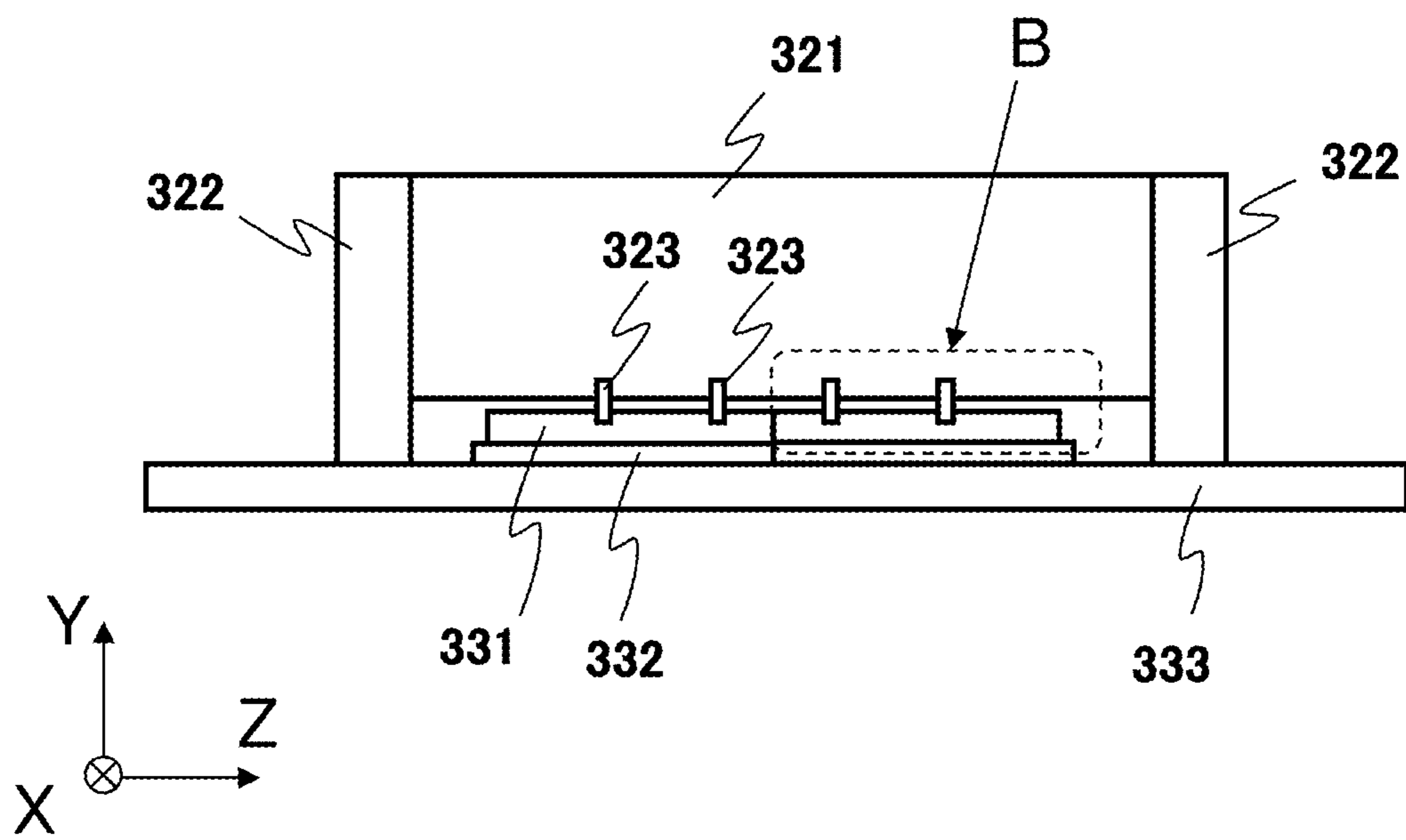

FIG. 4

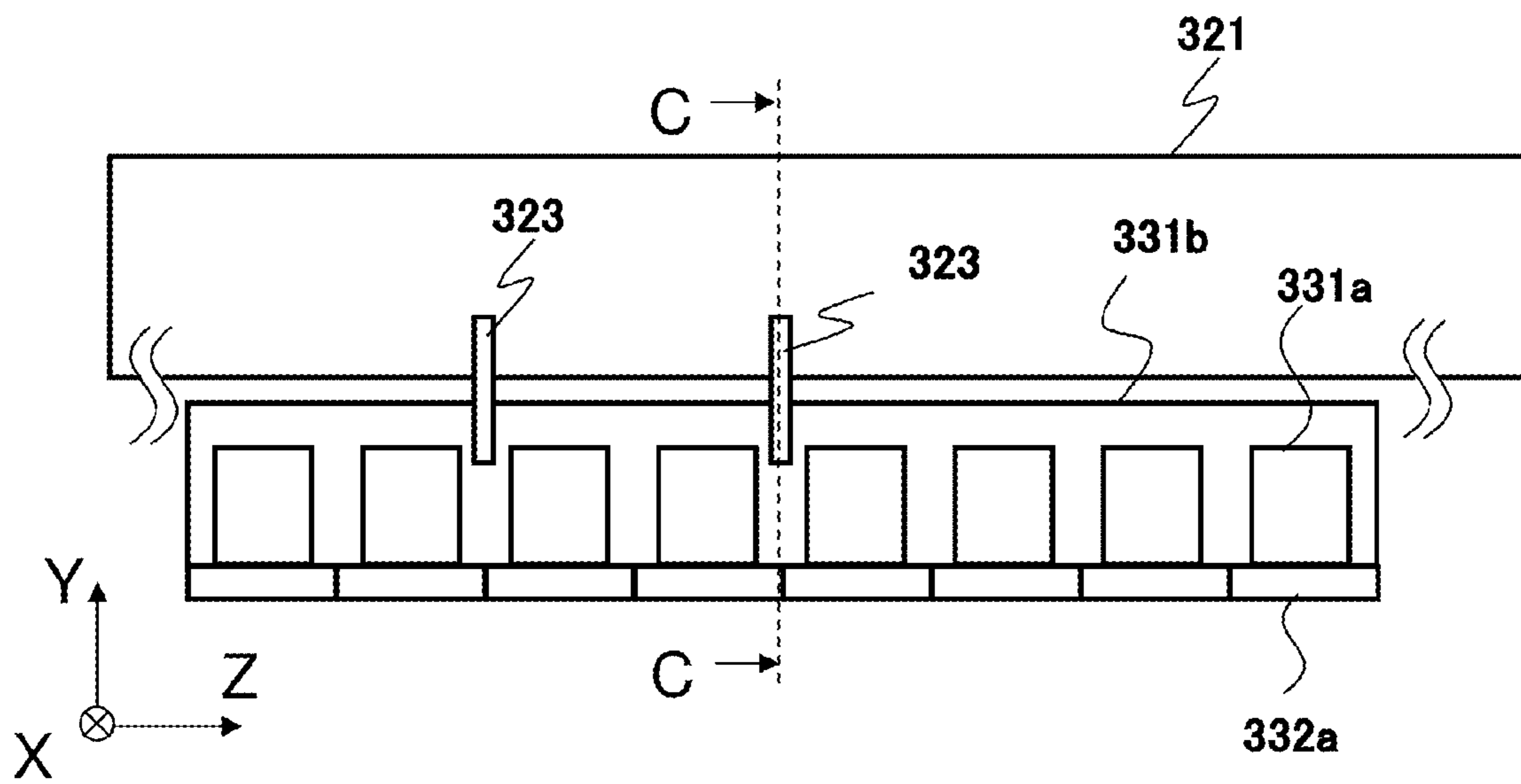

FIG. 5

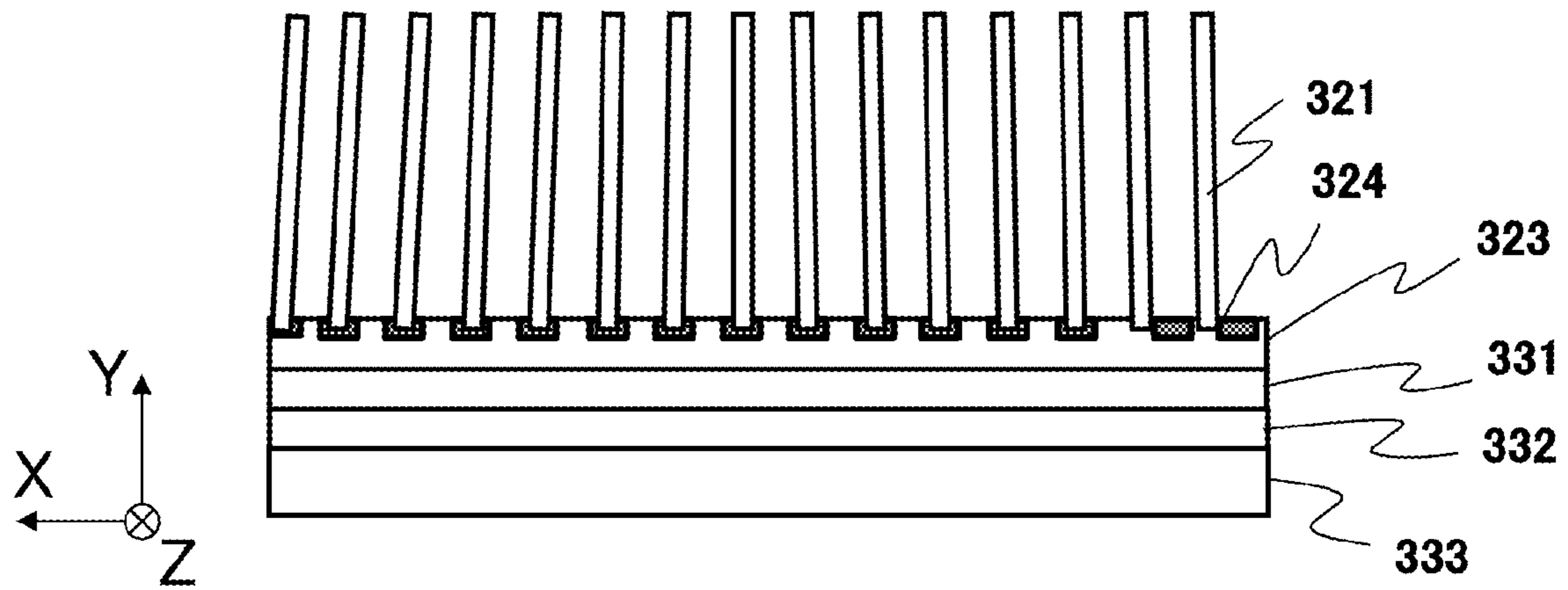
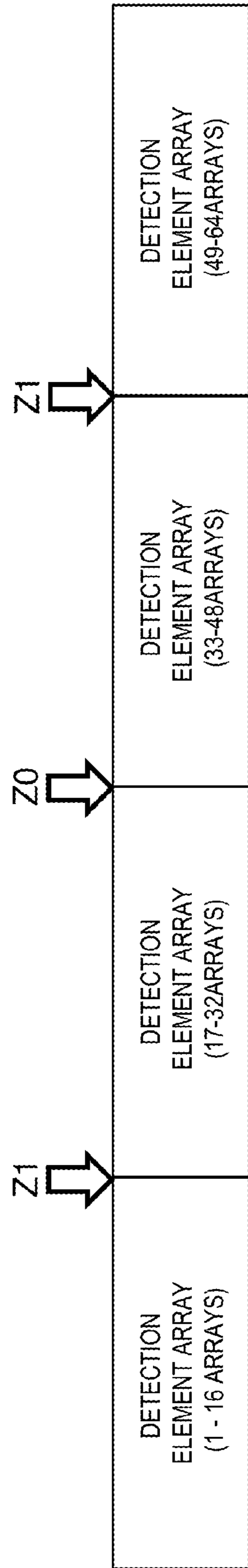
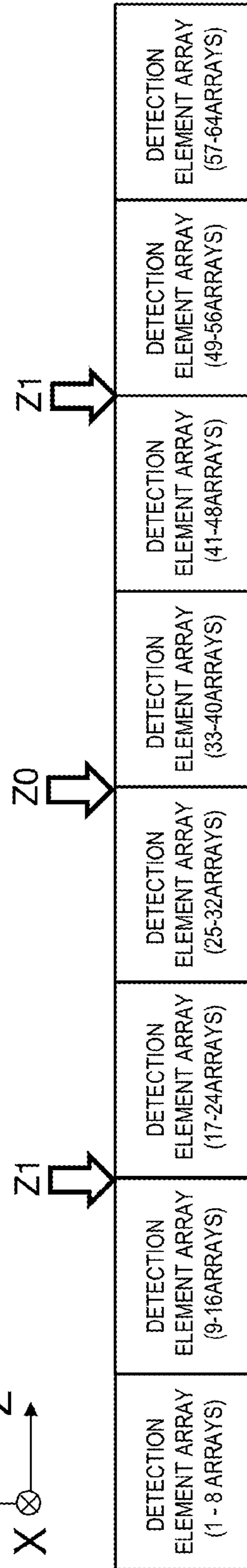
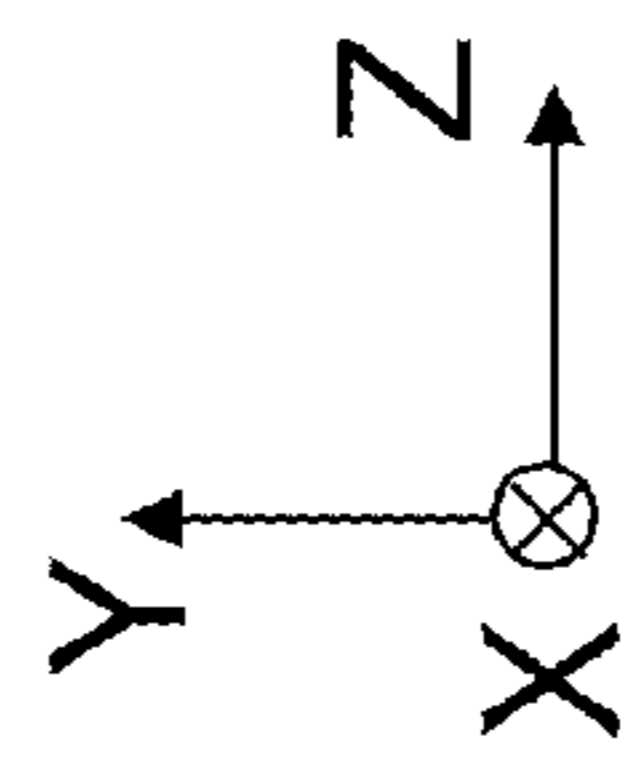

FIG. 6



(a)



(b)

FIG. 7

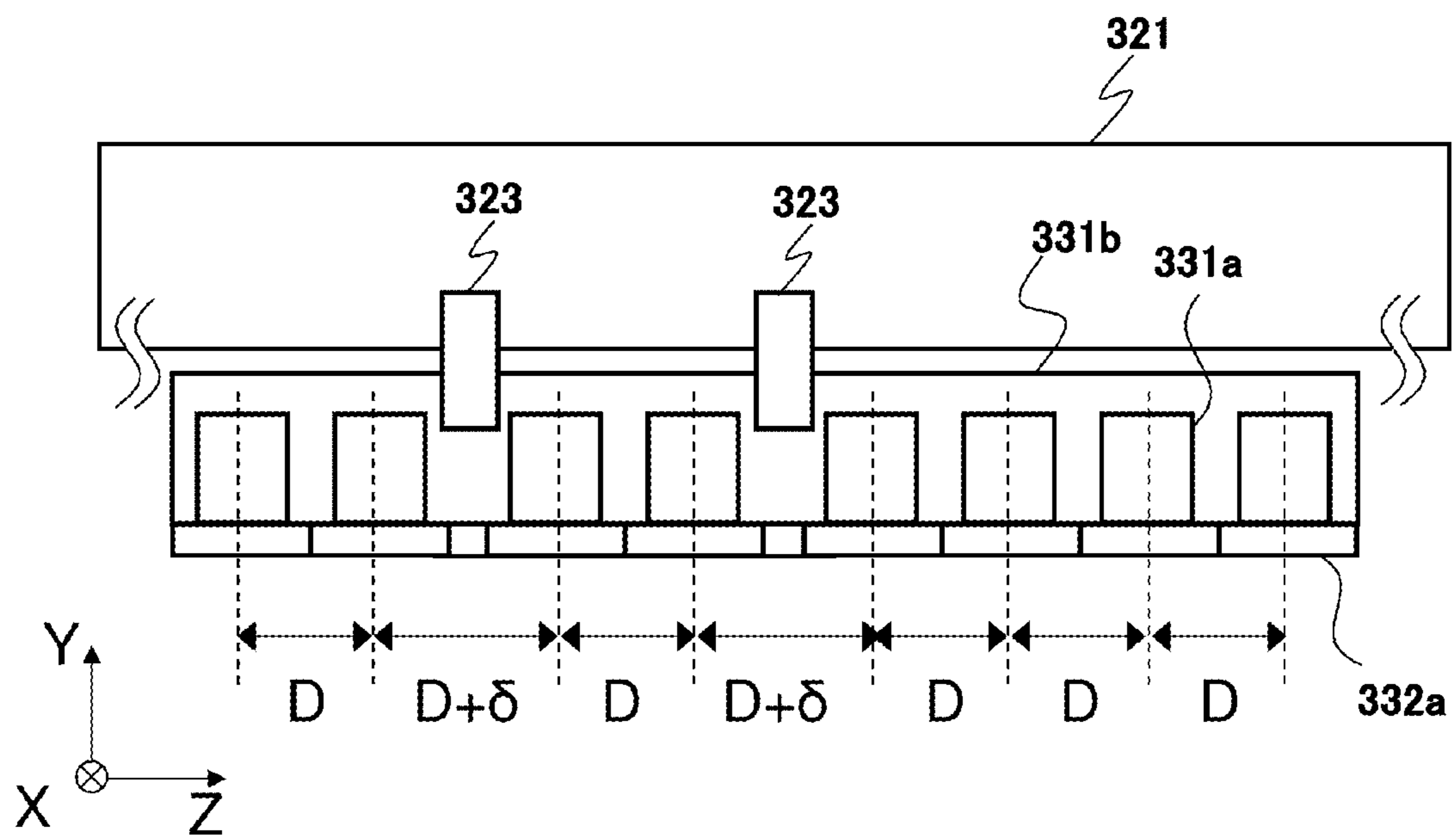

FIG. 8

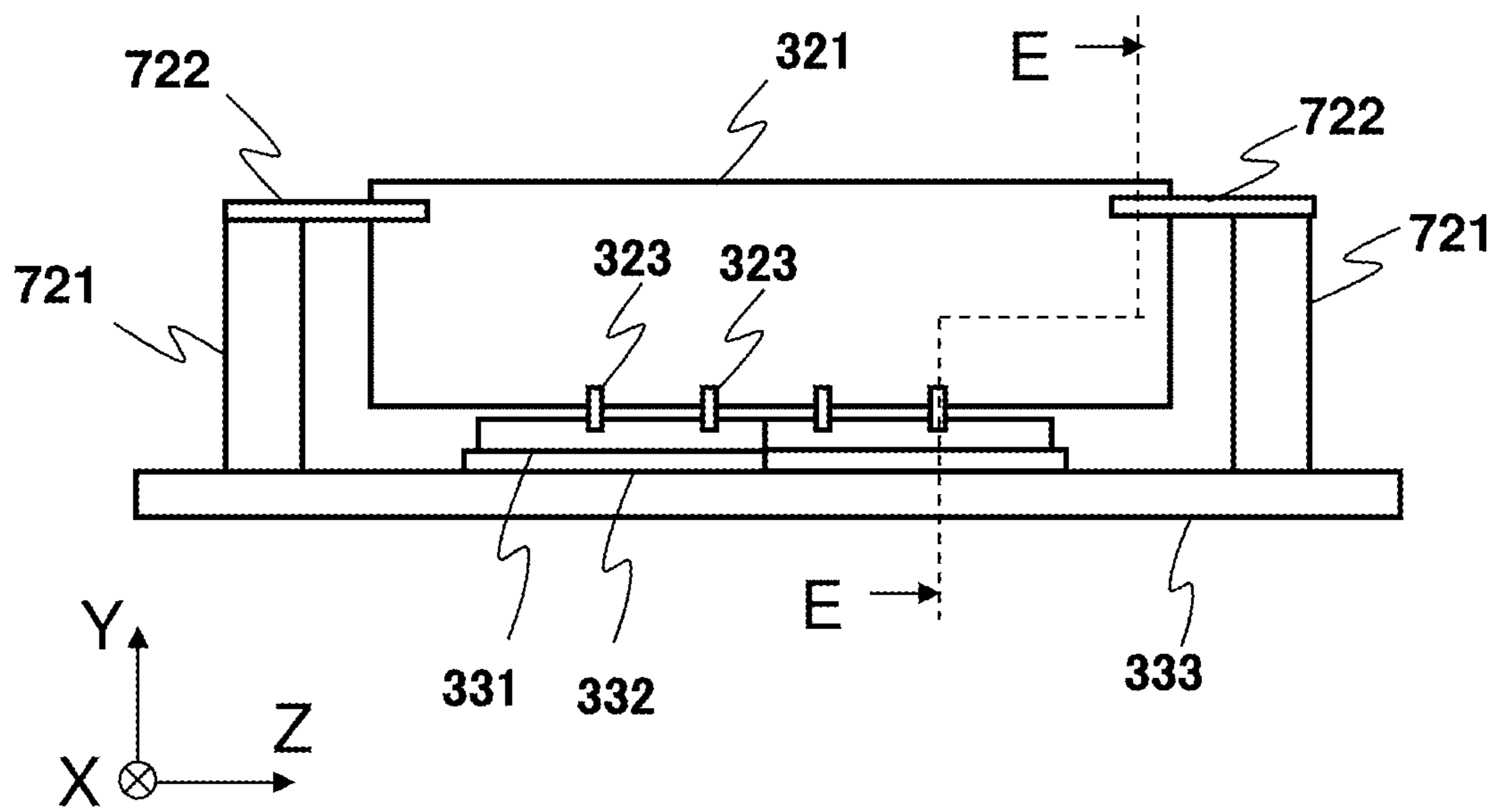
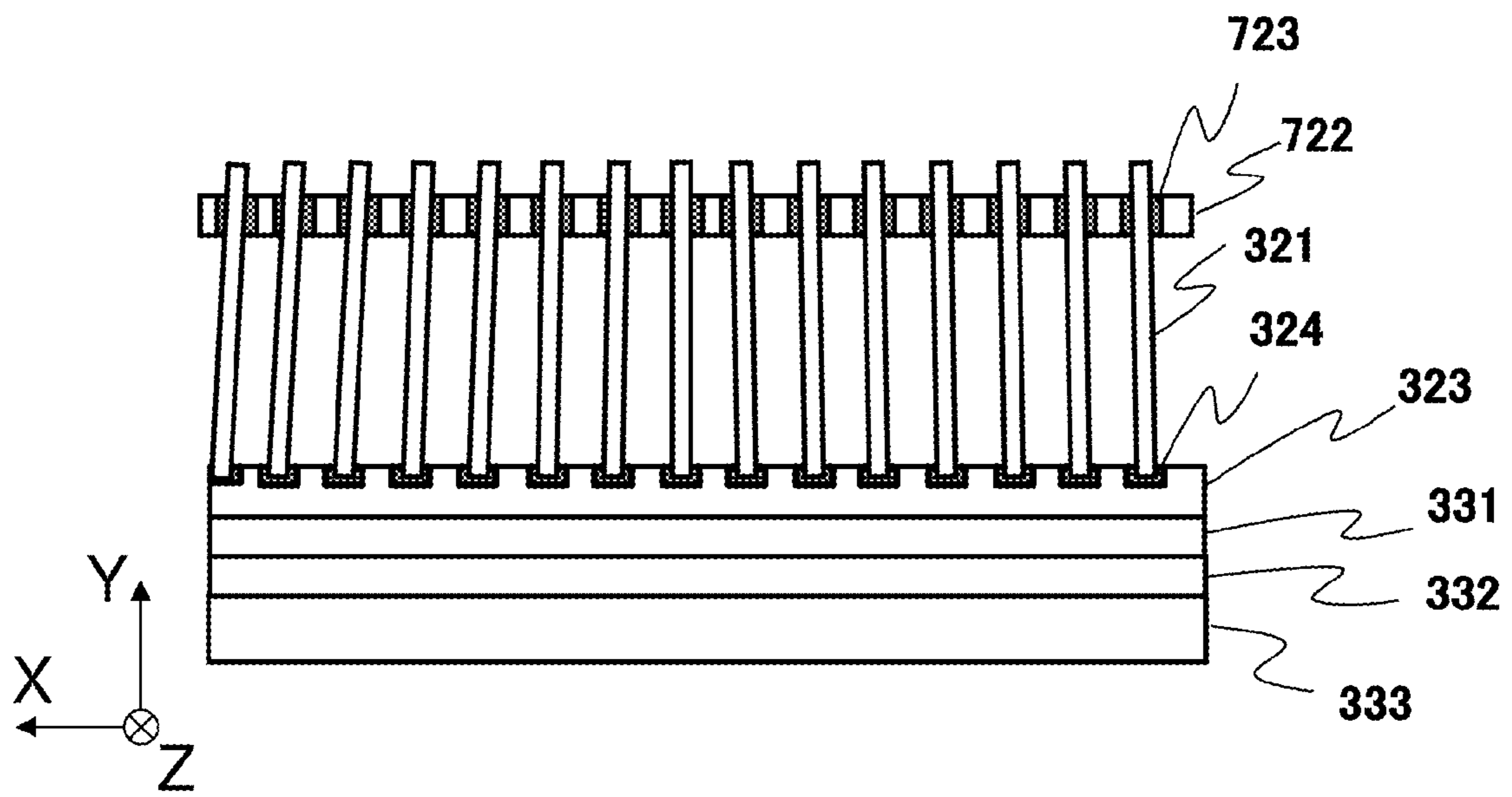

FIG. 9



RADIATION DETECTOR AND X-RAY CT APPARATUS PROVIDED THEREWITH

TECHNICAL FIELD

The present invention relates to a radiation detector detecting an X-ray, y-ray, etc., and particular to a support member supporting a collimator plate to be provided on the radiation source side of the radiation detector in order to remove scattered radiations. The present invention relates also to an X-ray Ct apparatus provided with such a radiation detector.

BACKGROUND ART

An X-ray CT (Computed Tomography) apparatus that is one of medical image diagnostic apparatuses reconstructs a tomographic image of an object using projection data from multiple angles that can be obtained by rotating an X-ray tube device irradiating an X-ray to the object and an X-ray detector detecting distribution of the X-ray dose transmitted through the object as the projection data around the object to display the reconstructed tomographic image. The image to be displayed on the X-ray CT apparatus draws organ shapes inside the object and is used for image diagnosis.

As a radiation detector represented by an X-ray detector used for an X-ray CT apparatus, an indirect-conversion-type detector, which is provided with a detection element in which a phosphor element such as a ceramic scintillator and a light detecting element such as a photodiode are combined, is used mainly. Also, a direct-conversion-type detector, which is provided with a semiconductor element as a detection element, has been recently used. In either type of the radiation detector, a structure in which approximately one thousands of detection elements are arranged on an arc around an X-ray focus in the rotation plane and a plurality of the detection element arrays are further arranged in the rotation axis direction is adopted. Also, a number of collimator plates are provided along the rotation axis direction on the X-ray tube device side of the X-ray detector in order to remove a scattered X-ray from an X-ray transmitted through an object. The collimator plates are made of thin metal plates that can shield an X-ray sufficiently and arranged radially toward the X-ray focus.

In a modern X-ray CT apparatus, it is promoted that the rotation speed and the number of detection element arrays are increased mainly in order to shorten an examination time. Increasing the rotation speed increases a centrifugal force applied to a collimator plate, and increasing the number of detection element arrays extends a length of a collimator plate in the rotation axis direction, which results in reducing the collimator plate strength. Therefore, as the rotation speed and the number of detection element arrays are increased, a collimator plate can be easily deformed during CT scanning. The deformed collimator plate changes an amount of X-ray incident on a detection element, which causes artifact generation on a tomographic image. The patent literature 1 discloses an X-ray detector capable of reducing the collimator plate deformation and an X-ray CT apparatus therewith.

CITATION LIST

Patent Literature

PTL 1: International Patent No. 2011/074470

SUMMARY OF INVENTION

Technical Problem

In PTL 1, there is a groove provided on a resin support plate disposed parallel to an X-ray incident plane of an X-ray detector, and one end of a collimator plate is connected by engaging it in the groove provided along the rotation axis direction. In such a structure, as the number of the detection element arrays increases, the collimator plate and the groove extend the lengths in the rotation axis direction, which makes it difficult to engage the collimator plate in the groove.

Therefore, the purpose of the present invention is to provide a radiation detector and an X-ray CT apparatus in which collimator plates can be easily arranged.

Solution to Problem

In order to achieve the above purpose, the present invention is characterized by comprising radiation detection element arrays in which a plurality of radiation detection elements detecting a radiation generated from a radiation source are arranged in a first direction and a second direction orthogonal to the first direction, collimator plates arranged along the first direction on the radiation source side of the radiation detection element arrays to remove scattered radiations, and collimator plate support members that have grooves supporting the collimator plate and are arranged along the second direction between the radiation detection elements.

Advantageous Effects of Invention

According to the present invention, it can provide a radiation detector and an X-ray CT apparatus in which collimator plates can be easily arranged.

BRIEF DESCRIPTION OF DRAWINGS

FIG. 1 is a block diagram showing the overall configuration of the X-ray CT apparatus 1 of the present invention.

FIG. 2 is a diagram explaining the positional relationship between the X-ray focus 201 and the X-ray detector 106.

FIG. 3 is a diagram showing the configuration of the first embodiment and the A-A cross-sectional diagram of FIG. 2.

FIG. 4 is a diagram showing the main part of the first embodiment and the enlarged view in B of FIG. 3.

FIG. 5 is a diagram showing the main part of the first embodiment and the C-C cross-sectional diagram of FIG. 4.

FIG. 6 is a diagram showing an example of positions where the collimator plate support members 323 are arranged.

FIG. 7 is a diagram showing the main part of the second embodiment.

FIG. 8 is a diagram showing the configuration of the third embodiment and the A-A cross-sectional diagram of FIG. 2.

FIG. 9 is a diagram showing the main part of the third embodiment and the E-E cross-sectional diagram of FIG. 7.

DESCRIPTION OF EMBODIMENTS

The radiation detector related to the present embodiment is characterized by comprising radiation detection element arrays in which a plurality of radiation detection elements detecting a radiation generated from a radiation source are arranged in a first direction and a second direction ortho-

nal to the first direction, collimator plates arranged along the first direction on the radiation source side of the radiation detection element arrays to remove scattered radiations, and collimator plate support members that have grooves supporting the collimator plate and are arranged along the second direction between the radiation detection elements.

Also, there are even numbers of the collimator plate support members, and they are characterized by being provided in symmetric positions on the basis of the central position in the first direction.

Also, a width between radiation detection elements where the collimator plate support members are arranged is characterized by being wider than a width between radiation detection elements where the collimator plate support members are not arranged.

Also, the radiation detection elements are characterized by that they are composed of scintillator elements for generating a visible light when a radiation is incident as well as light detection elements for outputting an electrical signal when the visible light is incident, that reflectors for reflecting the visible light are provided between scintillator elements, and that the collimator plate support members are composed of the same material as the reflectors.

Also, the X-ray CT apparatus related to the present embodiment is characterized by comprising the radiation source, the described radiation detector disposed opposite to the radiation source to detect a radiation transmitted through an object, a rotating disk equipped with the radiation source and the radiation detector and rotating around the object, an image reconstruction device for reconstructing a tomographic image of the object based on a transmitted radiation amount detected by the radiation detector from multiple angles, and an image display device for displaying the tomographic image reconstructed by the image reconstruction device.

Also, a position where collimator plate support members of the radiation detector are arranged is characterized by being a joint position of a maximum slice thickness during image reconstruction.

Hereinafter, the radiation detector and the X-ray CT apparatus of the present invention will be described in detail using the diagrams. Additionally, the repeated explanations of the components with the same functions are omitted by providing the same symbols in the following descriptions and the attached diagrams. Also, in order to help find a direction of each diagram, the XYZ coordinate system is shown in the lower left of each diagram.

(First Embodiment)

First, the overall configuration of the X-ray CT apparatus of the present invention that is an example of medical image diagnostic apparatuses will be described using FIG. 1. FIG. 1 is a block diagram showing the overall configuration of the X-ray CT apparatus 1. As shown in FIG. 1, the X-ray CT apparatus 1 comprises the scan gantry unit 100 and the operation unit 120.

The scan gantry unit 100 comprises the X-ray tube device 101, the rotating disk 102, the collimator 103, the X-ray detector 106, the data collection device 107, the bed device 105, the gantry controller 108, the bed controller 109, the X-ray controller 110, and the high voltage generating device 111.

The X-ray tube device 101 is a device for irradiating an X-ray to an object placed on the bed device 105. The collimator 103 is a device for restricting a radiation range of an X-ray irradiated from the X-ray tube device 101. The rotating disk 102 is equipped with the X-ray tube device 101

and the X-ray detector 106, comprises the opening 104 for accommodating the object placed on the bed device 105, and rotates around the object.

The X-ray detector 106 is a device for measuring spatial distribution of transmitted X-rays by detecting an X-ray transmitted through an object placed opposite to the X-ray tube device 101, in which many X-ray detection elements are arranged in two dimensions of the circumferential direction in the rotation plane (XY plane) of the rotating disk 102 and the rotation axis direction (parallel to the Z axis). Additionally, the details of the X-ray detector 106 will be described later.

The data collection device 107 is a device for collecting an X-ray amount detected by the X-ray detector 106 as digital data. The gantry controller 108 is a device for controlling the rotation of the rotating disk 102. The bed controller 109 is a device for controlling up, down, left, right, back, and forth movements of the bed device 105. The high voltage generating device 111 is a device for generating a high voltage to be applied to the X-ray tube device 101. The X-ray controller 110 is a device for controlling the output of the high voltage generating device 111.

The operation console 120 comprises the input device 121, the image calculation device 122, the display device 125, the storage device 123, and the system controller 124. The input device 121 is a device for inputting an object name, an examination date, scanning conditions, etc. and is specifically a keyboard or a pointing device. The image calculation device 122 is a device for performing a calculation process for measurement data sent from the data collection device 107 to reconstruct a CT image. The display device 125 is a device for displaying a CT image generated by the image calculation device 122 and is specifically a CRT (Cathode-Ray Tube), a liquid crystal display, or the like. The storage device 123 is a device for storing data collected by the data collection device 107 and image data of the CT image generated by the image calculation device 122 and is specifically an HDD (Hard Disk Drive) or the like. The system controller 124 is a device for controlling these devices, the gantry controller 108, the bed controller 109, and the X-ray controller 110.

The X-ray controller 110 controls the high voltage generating device 111 based on scanning conditions input from the input device 121, such as a tube voltage and a tube current particularly, which supplies predetermined electric power from the high voltage generating device 111 to the X-ray tube device 101. The X-ray tube device 101 irradiates an X-ray according to the scanning conditions to an object using the supplied electric power. The X-ray detector 106 detects an X-ray irradiated from the X-ray tube device 101 and transmitted through the object using many X-ray detection elements to measure distribution of the transmitted X-ray. The rotating disk 102 is controlled by the gantry controller 108 and rotates based on scanning conditions input from the input device 121, such as a rotation speed particularly. The bed device 105 is controlled by the bed controller 109 and operates based on scanning conditions input from the input device 121, such as a helical pitch particularly.

By repeating an X-ray irradiation from the X-ray tube device 101 and a measurement of distribution of transmitted X-rays using the X-ray detector 106 together with rotation of the rotating disk 102, projection data from various angles are acquired. The projected data is associated with a view that shows each angle and a channel (ch) number as well as an array number that are detection element numbers of the X-ray detector 106. The acquired projection data from

various angles is transmitted to the image processing device **122**. The image processing device **122** performs a back projection process for the transmitted projection data from various angles to reconstruct a CT image. The CT image acquired by the reconstruction is displayed on the display device **125**.

The X-ray detector **106** will be described using FIG. 2. FIG. 2 is a diagram showing the positional relationship between the X-ray focus **201** and the X-ray detector **106**. The X-ray detector **106** comprises the scattered radiation remover **202** and the detection element modules **203**.

The scattered radiation remover **202** removes scattered radiations generated by an object or the like and is configured so that the metal thin plates which can sufficiently shield an X-ray are disposed radially toward the X-ray focus **201** as described later. When an X-ray including scattered radiations is detected by the X-ray detector **106**, an X-ray amount reduced by the object is not measured properly, which deteriorates the image quality of the reconstructed tomographic image.

The detection element modules **203** measures spatial distribution of an X-ray transmitted through the scattered radiation remover **202** and configured so that X-ray detection elements measuring an X-ray amount are arranged on a flat plate two-dimensionally. The X-ray detector **106** is provided with a plurality of the detection element modules **203**, and the respective detection element modules **203** are arranged so as to be a polygonal shape formed by tangent lines of the arc around the X-ray focus **201** on the rotating plane (XY plane) of the rotating disk **102**. By thus arranging the respective detection element modules **203**, X-ray detection elements are almost arranged on the arc around the X-ray focus **201**. Additionally, although the only seven detection element modules **203** are drawn in FIG. 2 in order to simplify the diagram, the number of the detection element modules **203** is not limited to seven.

The scattered radiation remover **202** and the detection element modules **203** will be described using FIGS. 3 to 5. FIG. 3 is the A-A cross-sectional diagram in FIG. 2, and the left and right direction is the rotation direction (parallel to the Z axis) of the rotating disk **102**. FIG. 4 is the enlarged view in B of FIG. 3. FIG. 5 is the C-C cross-sectional diagram in FIG. 4, and the direction perpendicular to a plane where the diagram is drawn is the rotation axis direction (parallel to the Z axis) of the rotating disk **102**.

The detection element module **203** comprises the substrate **333**, the light detection element array **332**, and the scintillator element array **331**. The scattered radiation remover **202** comprises the collimator plate **321**, the grooved pillar **322**, and the collimator plate support members **323**.

The substrate **333** holds the light detection element array **332** and the grooved pillar **322** and is made of glass epoxy or the like.

The light detection element array **332** is installed on the upper plane of the substrate **333**, on which the light detection elements **332a** detecting light emission of the scintillator element array **331** are arranged two-dimensionally. For example, a photodiode is used for the light detection elements **332a**.

The scintillator element array **331** is installed on the upper plane of the light detection element array **332**, on which the scintillator elements **331a** emitting visible lights in an amount according to the X-ray amount by receiving an X-ray light are partitioned with the light reflectors **331b** and arranged two-dimensionally. The scintillator elements **331** and the light detection elements **332a** are respectively asso-

ciated as a pair, and one X-ray detection element is composed of a pair of the scintillator element **331** and the light detection element **332a**. The light reflector **331b** reflects a visible light emitted by the scintillator element **331a** and is formed by fixing white powder such as titanium oxide with a transparent adhesive such as epoxy resin. The thicker the thickness of the light reflector **331b** is or the denser the concentration of the white powder in the light reflector **331b** is, the more the leakage of a visible light to an adjacent X-ray detection element can be reduced.

As the number of X-ray detection elements to be arrayed is increased for the light detection element array **332** and the scintillator element array **331**, the yield rate of the components is reduced, or the assembly difficulty is increased. Therefore, in order to avoid these problems, the number of the X-ray detection elements to be arrayed may be increased by dividing and combining at least one of the light detection element array **332**, the scintillator element array **331**, and the substrate **333**. FIG. 3 shows a configuration example where the light detection element array **332** and the scintillator element array **331** are respectively divided into two in the rotation axis direction and combined on one substrate **333**. The division mode is not limited to FIG. 3.

The collimator plate **321** is a thin metal plate that can shield an X-ray sufficiently and is formed with a plate member of a heavy metal such as tungsten and molybdenum. The collimator plates **321** are arranged so that shadows formed by the collimator plates **321** when the X-ray detector **106** is viewed from the X-ray focus **201** locate along the rotation axis direction (parallel to the Z axis between X-ray detection elements almost arranged on an arc. Specifically, the collimator plates **321** are arranged radially toward the X-ray focus **201** on the rotating plane (XY plane) of the rotating disk **102** or parallel to the rotation axis direction (parallel to the Z axis). By thus arranging the collimator plates **321**, direct radiations from the X-ray focus **201** are incident on the X-ray detection elements, scattered radiations generated by an object shielded are shielded by the collimator plates **321**, which prevents from being incident on the X-ray detection elements.

The grooved pillars **322** support the collimator plate **321** at the end of the rotation axis direction (parallel to the Z axis), have grooves on the sides that are not shown in the diagram, and are installed on the substrate **333**. The grooves of the grooved pillars **322** are formed radially toward the X-ray focus **201** in the rotation plane (XY plane). By inserting the collimator plate **321** in the grooves of the grooved pillars **322**, the collimator plates **321** are arranged radially toward the X-ray focus **201** in the rotation plane (XY plane). The collimator plate **321** and the grooved pillars **322** may be fixed by an adhesive.

The collimator plate support members **323** support the collimator plate **321** from the X-ray detector **106** side and is installed on the scintillator element array **331**. The collimator plate support members **323** are arranged between X-ray detection elements aligned along the rotation axis direction (parallel to the Z axis) and have the grooves **324** to insert the collimator plates **321**. The grooves **324** are formed between the X-ray detection elements almost aligned on an arc in the rotation plane (XY plane). The shape of the groove **324** may not be limited unless the shape does not hinder the collimator plates **321** to be inserted from being arranged radially toward the X-ray focus **201**. Also, the collimator plate **321** inserted in the grooves **324** may be fixed by an adhesive.

The thickness of the collimator plate support member **323** is formed thinner than a gap between X-ray detection elements aligned along the rotation axis direction so that the

collimator plate support member **323** does not come into contact with the scintillator element **331** forming an X-ray detection element. In order to reduce absorption of an X-ray by the collimator plate support members **323**, it is desirable that the material of the collimator plate support members **323** is, for example, an epoxy resin or the like whose X-ray absorption rate is low. Also, in order to reduce an amount of which the collimator plate support members **323** absorb a visible light generated from the scintillator element **331a**, it is desirable that the material of the collimator plate support members **323** is the same as that of the light reflector **331b**.

Although the collimator plate support members **323** may be arranged in any positions between X-ray detection elements aligned along the rotation axis direction, the collimator plate support members **323** should be desirably arranged in symmetrical positions based on the central position of the X-ray detector in the rotation axis direction. The collimator plate support members **323** are arranged in symmetrical positions in the rotation axis direction, which can support the collimator plates **321** more uniformly.

Additionally, the collimator plate support members **323** are arranged desirably in joint positions of the maximum slice thickness in the rotation axis direction during image reconstruction. A multi-slice detector in which a plurality of X-ray detection element arrays are aligned in the rotation axis direction can reconstruct an image for each X-ray detection element array as well as acquire an image with a thick slice by adding plural arrays of measurement data. For example, a 64-array multi-slice detector can acquire 64 images in one measurement as well as acquire four images at a 16-time thickness by adding 16 arrays of measurement data. By the way, if there is a foreign substance like the collimator plate support member **323** in a slice thickness, the image quality of the image with the said slice thickness can be deteriorated.

Therefore, in order to prevent such image quality deterioration, it is desirable that the collimator plate support members **323** are arranged in joint positions of the maximum slice thickness during image reconstruction. A specific arrangement example will be described using FIG. 6. FIG. 6 is the schematic diagram of the 64-array multi-slice detector, FIG. 6(a) shows a case of adding 16 arrays of measurement data, and FIG. 6(b) shows a case of adding 8 arrays of measurement data. In a case of forming the maximum slice thickness by 16 arrays in the multi-slice detector of FIG. 6, the Z0 and Z1 positions in the diagram are joint positions of the maximum slice thickness. If the collimator plate support members **323** are arranged in these positions, the collimator plate support members **323** do not exist in a said slice thickness whatever the thickness is.

That is, not only when adding 16 arrays of measurement data shown in FIG. 6(a), but also when adding 8 arrays of measurement data shown in FIG. 6(b), or even when adding 4 or 2 arrays of measurement data that is not shown in the diagram, there is no foreign substance like the collimator plate support member **323** in a slice thickness, which can prevent image quality deterioration.

Additionally, it may be configured so that the collimator plate support members **323** are arranged out of the center position of the X-ray detector in the rotation axis direction. The center position of the X-ray detector in the rotation axis direction, i.e. the Z0 position in FIG. 6 is a position where a high-quality tomographic image is easily acquired because an X-ray incident on the X-ray detection element is approximately orthogonal to the incident plane. If there is a foreign substance like the collimator plate support member **323** in

such a position, the image quality of the high-quality tomographic image can be deteriorated.

Therefore, it may be configured so that the collimator plate support members **323** are arranged out of the center position of the X-ray detector in the rotation axis direction. By thus arranging the collimator plate support members **323**, the image quality deterioration in a position where a high-quality tomographic image is easily acquired can be prevented.

According to the configuration described above, even if the number of detection element arrays increases, the collimator plates **321** can be easily inserted in the grooves **324** of the collimator plate support members **323**, which can provide a radiation detector facilitating arrangement of the collimator plates **321** as well as an X-ray CT apparatus equipped with such a radiation detector.

Also, by selecting a material of the collimator plate support member **323** properly, output reduction of the X-ray detector due to the collimator plate support members **323** can be reduced. Additionally, image quality deterioration can be prevented by arranging the collimator plate support members **323** in appropriate positions.

(Second Embodiment)

The second embodiment will be described using FIG. 7. The point different from the first embodiment is that X-ray detection elements have irregular gaps partly in the rotation axis direction (parallel to the Z axis), and the same descriptions will be omitted because the others are the same as the first embodiment. Additionally, FIG. 7 can be substituted for FIG. 4 of the first embodiment.

Depending on the material and the number of the collimator plate support members **323**, there is a case of lacking the mechanical strength of the collimator plate support members **323** formed thinner than gaps between X-ray detection elements aligned along the rotation axis direction to support the collimator plates **321**. In order to supplement the insufficient mechanical strength of the collimator plate support members **323**, the thickness of the collimator plate support members **323** should be increased. However, if the collimator plate support members **323** are thicker than the gaps between the X-ray detection elements aligned along the rotation axis direction, the collimator plate support members **323** interfere with the X-ray detection elements, which results in lowering output signals of the X-ray detection elements adjacent to the collimator plate support members **323**.

Therefore, in the present embodiment, the widths between the X-ray detection elements where the collimator plate support members **323** are arranged are made wider than those between the X-ray detection elements where the collimator plate support members **323** are not arranged so that the collimator plate support members **323** do not interfere with the X-ray detection elements even when the thickness of the collimator plate support members **323** is increased to supplement the insufficient mechanical strength. Specifically, as shown in FIG. 7, the widths between the X-ray detection elements where the collimator plate support members **323** are arranged are expressed as $D+\delta$ ($\delta \neq 0$) while the widths between the X-ray detection elements where the collimator plate support members **323** are not arranged are expressed as D . Additionally, in case of such a configuration, because the X-ray detection elements have irregular gaps partly in the rotation axis direction, the image calculation device **122** performs a process to correct a positional shift in the rotation axis direction for measurement data sent from the data collection device **107** before an inverse projection process is performed.

According to the configuration described above, even if the number of detection element arrays increases, the collimator plates **321** can be easily inserted in the grooves **324** of the collimator plate support members **323**, which can provide a radiation detector facilitating arrangement of the collimator plates **321** as well as an X-ray CT apparatus equipped with such a radiation detector. Additionally, the radiation detector can be configured without causing insufficient mechanical strength of the collimator plate support members **323**.

(Third Embodiment)

The third embodiment will be described using FIGS. **8** and **9**. The point different from the first embodiment is that the pillars **721** and the grooved flat plates **722** are used instead of the grooved pillars **322**, and the same descriptions will be omitted because the others are the same as the first embodiment. Additionally, FIG. **8** can be substituted for FIG. **3** of the first embodiment. Also, FIG. **9** is the E-E cross-sectional diagram in FIG. **8** and can be substituted for FIG. **5** of the first embodiment.

The pillars **721** support the grooved flat plates **722** and are installed on the substrate **333**. The height of the pillars **721** is lower than the height of which the light detection element array **332**, the scintillator element array **331**, the collimator plate support members **323**, and the collimator plate **321** are assembled.

The grooved flat plates **722** support the collimator plate **321** from the rotation axis direction and are installed on the upper ends of the pillars **721**. The grooved flat plate **722** has the groove **723** to insert the collimator plate **321**, and the position of the groove **723** is between X-ray detection elements in the rotation plane (XY plane). The gap between the respective grooves **723** is slightly narrower than that between the grooves **324** provided for the collimator plate support members **323**, and the grooves **723** as well as the grooves **324** are provided so that the collimator plates **321** are arranged radially toward the X-ray focus **201**. The shape of the groove **723** may not be limited unless the shape does not hinder the collimator plates **321** from being arranged radially toward the X-ray focus **201**. Also, the collimator plate **321** inserted in the grooves **723** may be fixed by an adhesive.

In case of the grooved flat plates **722** having such a structure, a groove process can be simultaneously performed for a plurality of accumulated flat plates, which can reduce the processing cost. Also, in the directions between the X-ray focus **201** and the respective detection elements, the length of the groove **723** of the grooved flat plate **722** is shorter than that of the groove of the grooved pillar **322** in the first embodiment, which can insert the collimator plate **321** easily.

According to the configuration described above, even if the number of detection element arrays increases, the collimator plates **321** can be easily inserted in the grooves **324** of the collimator plate support members **323**, which can provide a radiation detector facilitating arrangement of the collimator plates **321** as well as an X-ray CT apparatus equipped with such a radiation detector. Additionally, the collimator plates **321** can be easily inserted in the grooves **723** of the grooved flat plate **722**.

Additionally, the embodiments described above are not for limiting the structure of the present invention but examples showing specific embodiments, and the present invention can be achieved even in the other embodiments having the same effect. For example, although an indirect conversion type of detector in which the scintillator element array **331** and the light detection element array **332** are

combined are described in the above embodiments, the present invention can be achieved also by a direct conversion type of detector in which the combination of the scintillator element array **331** and the light detection element array **332** is replaced with a semiconductor element array.

Also, although the embodiments are described by taking an X-ray detector as an example, the present invention also includes a radiation detector such as a detector detecting a y ray. Also, although an X-ray tube device is described as an example of a radiation source, a y ray generating source using an isotope may be used.

DESCRIPTION OF REFERENCE NUMERALS

- 1**: X-ray CT apparatus
- 100**: scan gantry unit
- 101**: X-ray tube device
- 102**: rotating disk
- 103**: collimator
- 104**: opening
- 105**: bed device
- 106**: X-ray detector
- 107**: data collection device
- 108**: gantry controller
- 109**: bed controller
- 110**: X-ray controller
- 111**: high voltage generating device
- 120**: operation console
- 121**: input device
- 122**: image calculation device
- 123**: storage device
- 124**: system controller
- 125**: display device
- 201**: X-ray focus
- 202**: scattered radiation remover
- 203**: detection element module
- 321**: collimator plate
- 322**: grooved pillar
- 323**: collimator plate support member
- 324**: groove
- 331**: scintillator element array
- 331a**: scintillator element
- 331b**: light reflector
- 332**: light detection element array
- 332a**: light detection element
- 333**: substrate
- 721**: pillar
- 722**: grooved flat plate
- 723**: groove

The invention claimed is:

1. A radiation detector, comprising:
 - radiation detection element arrays in which a plurality of radiation detection elements detecting a radiation generated from a radiation source are arranged in a first direction and a second direction orthogonal to the first direction;
 - collimator plates that are arranged along the first direction on the radiation source side of the radiation detection element arrays to remove scattered radiations; and
 - collimator plate support members that have grooves supporting the collimator plate and are arranged along the second direction between the radiation detection elements;
- wherein a width between radiation detection elements where the collimator plate support members are

11

arranged is wider than a width between radiation detection elements where the collimator plate support members are not arranged.

2. The radiation detector according to claim 1, wherein there are even numbers of the collimator plate support members, and they are provided in symmetric positions on the basis of the central position in the first direction.
3. The radiation detector according to claim 1, wherein the radiation detection elements are composed of scintillator elements for generating a visible light when a radiation is incident as well as light detection elements for outputting an electrical signal when the visible light is incident, reflectors for reflecting the visible light are provided between the scintillator elements, and the collimator plate support members are composed of the same material as the reflectors.
4. An X-ray CT apparatus, comprising: the radiation source; the radiation detector according to claim 1, that is disposed opposite to the radiation source

12

to detect a radiation transmitted through an object; a rotating disk that is equipped with the radiation source and the radiation detector and rotating around the object; and image reconstruction device for reconstructing a tomographic image of the object based on a transmitted radiation amount detected by the radiation detector from multiple angles; and an image display device for displaying the tomographic image reconstructed by the image reconstruction device.

5. The X-ray CT apparatus according to claim 4, wherein the X-ray CT apparatus has a predetermined maximum slice thickness for image reconstruction, and wherein a position where collimator plate support members of the radiation detector are arranged is a joint position of the maximum slice thickness.
6. The radiation detector according to claim 1, wherein the collimator plate support members include an epoxy resin.

* * * * *