



US009812757B2

(12) **United States Patent**
Srirattana et al.

(10) **Patent No.:** **US 9,812,757 B2**
(45) **Date of Patent:** **Nov. 7, 2017**

(54) **RF COUPLER HAVING COUPLED LINE WITH ADJUSTABLE LENGTH**

(56) **References Cited**

(71) Applicant: **SKYWORKS SOLUTIONS, INC.**,
Woburn, MA (US)
(72) Inventors: **Nuttapong Srirattana**, Billerica, MA
(US); **David Scott Whitefield**, Andover,
MA (US); **David Ryan Story**, Ladera
Ranch, CA (US); **Zhiyang Liu**,
Dunstable, MA (US)
(73) Assignee: **SKYWORKS SOLUTIONS, INC.**,
Woburn, MA (US)

U.S. PATENT DOCUMENTS

3,611,199 A * 10/1971 Safran H01P 1/185
333/109
3,868,594 A 2/1975 Cornwell et al.
4,460,875 A 7/1984 Harman
4,677,399 A 6/1987 Le Dain et al.
4,764,740 A * 8/1988 Meyer H01P 1/185
333/103
5,038,112 A * 8/1991 O'Neill H03G 7/00
330/207 P
5,222,246 A 6/1993 Wolkstein
5,276,411 A 1/1994 Woodin, Jr. et al.
(Continued)

(*) Notice: Subject to any disclaimer, the term of this
patent is extended or adjusted under 35
U.S.C. 154(b) by 0 days.

FOREIGN PATENT DOCUMENTS

EP 2503701 A2 9/2012
JP S62-159502 A 7/1987
(Continued)

(21) Appl. No.: **14/745,213**

(22) Filed: **Jun. 19, 2015**

OTHER PUBLICATIONS

(65) **Prior Publication Data**
US 2016/0172740 A1 Jun. 16, 2016

Invitation to Pay Additional Fees from the International Searching
Authority for corresponding International Application No. PCT/
US2015/064444 dated Apr. 1, 2016.
(Continued)

Related U.S. Application Data

(60) Provisional application No. 62/090,015, filed on Dec.
10, 2014, provisional application No. 62/110,248,
filed on Jan. 30, 2015.

Primary Examiner — Dean Takaoka
(74) *Attorney, Agent, or Firm* — Lando & Anastasi, LLP

(51) **Int. Cl.**
H01P 5/18 (2006.01)
H01P 5/12 (2006.01)
(52) **U.S. Cl.**
CPC *H01P 5/185* (2013.01)
(58) **Field of Classification Search**
CPC H01P 5/18
USPC 333/109–112, 116
See application file for complete search history.

(57) **ABSTRACT**
Aspects of this disclosure relate to a radio frequency coupler
with a multi-section coupled line. In an embodiment, an
apparatus includes a radio frequency coupler that includes a
power input port, a power output port, a coupled port, a
multi-section coupled line, and a switch configured to adjust
an effective length of the multi-section coupled line electri-
cally connected to the coupled port.

22 Claims, 27 Drawing Sheets

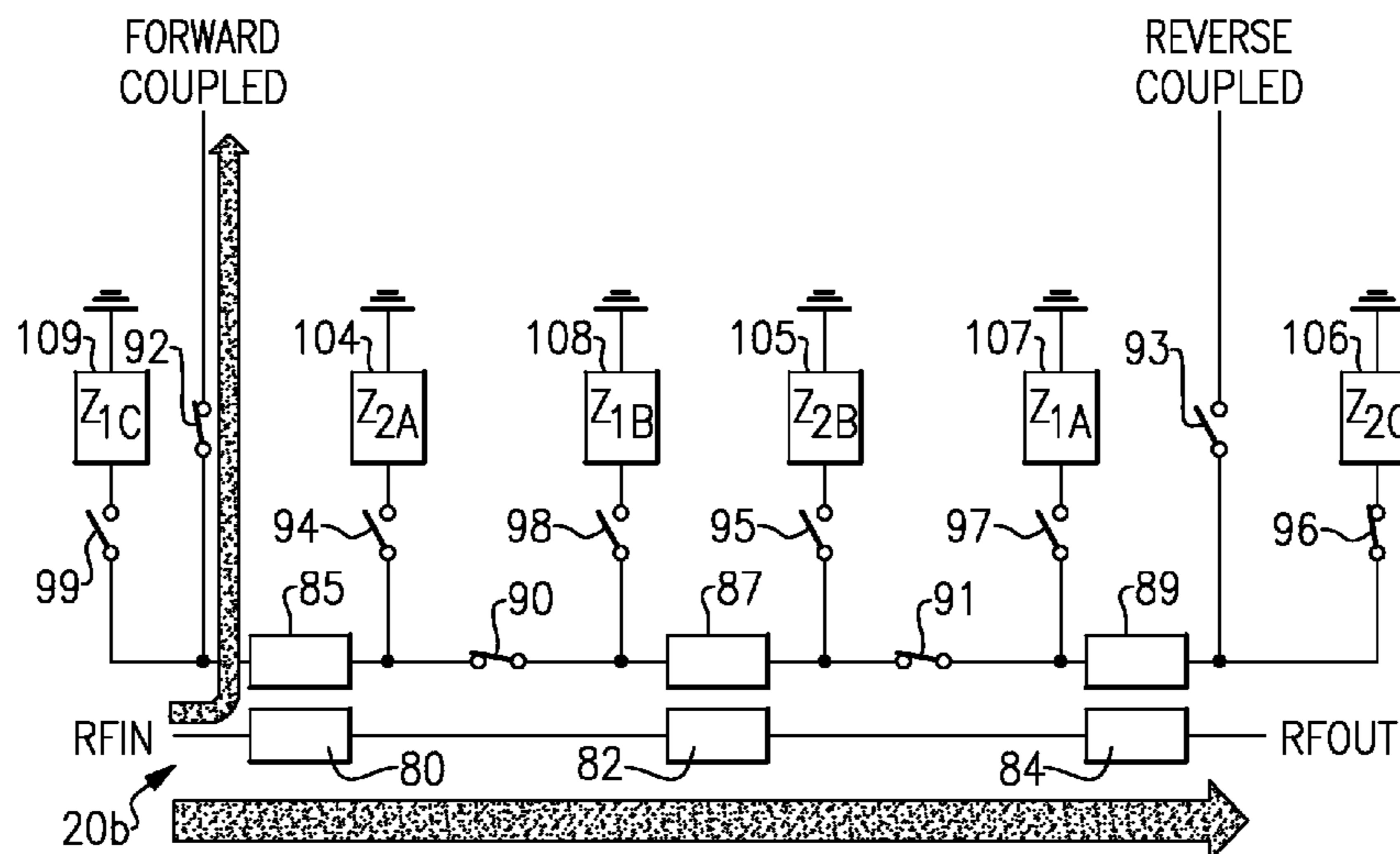

(56)

References Cited

U.S. PATENT DOCUMENTS

5,363,071 A * 11/1994 Schwent H01P 5/04
333/111

5,487,184 A 1/1996 Nagode

5,745,016 A * 4/1998 Salminen G01R 1/24
324/95

6,020,795 A 2/2000 Kim

6,078,299 A 6/2000 Scharfe, Jr.

6,108,527 A 8/2000 Urban et al.

6,329,880 B2 * 12/2001 Akiya 330/207 P

6,496,708 B1 12/2002 Chan et al.

6,771,141 B2 8/2004 Iida et al.

6,972,640 B2 12/2005 Nagamori et al.

7,042,309 B2 5/2006 Podell

7,305,223 B2 12/2007 Liu et al.

7,319,370 B2 1/2008 Napijalo

7,336,142 B2 2/2008 Vogel

7,493,093 B2 2/2009 Boerman et al.

7,538,635 B2 * 5/2009 Fukuda H01P 5/227
333/111

7,546,089 B2 * 6/2009 Bellantoni H01P 5/04
333/101

7,966,140 B1 6/2011 Gholson, III et al.

8,175,554 B2 5/2012 Camuffo et al.

8,248,302 B2 * 8/2012 Tsai H01P 1/18
333/117

8,289,102 B2 * 10/2012 Yamamoto H01P 5/184
333/116

8,315,576 B2 11/2012 Jones

8,417,196 B2 4/2013 Kitching et al.

8,606,198 B1 12/2013 Wright

9,014,647 B2 4/2015 Kitching et al.

9,214,967 B2 12/2015 Reisner et al.

9,356,330 B1 5/2016 Donoghue et al.

2002/0113666 A1 8/2002 Yamazaki et al.

2002/0139975 A1 10/2002 Lewis et al.

2004/0127178 A1 7/2004 Kuffner

2005/0040912 A1 2/2005 Pelz

2005/0146394 A1 7/2005 Podell

2005/0170794 A1 * 8/2005 Koukkari H01P 1/22
455/120

2005/0239421 A1 10/2005 Kim et al.

2006/0232359 A1 10/2006 Fukuda et al.

2007/0159268 A1 7/2007 Podell

2008/0070519 A1 3/2008 Okabe

2008/0112466 A1 5/2008 Sasaki

2009/0134953 A1 5/2009 Hunt et al.

2009/0278624 A1 11/2009 Tsai et al.

2009/0280755 A1 11/2009 Camuffo et al.

2009/0322313 A1 12/2009 Zhang et al.

2011/0057746 A1 3/2011 Yamamoto et al.

2011/0063044 A1 3/2011 Jones

2011/0199166 A1 8/2011 Carrillo-Ramirez

2011/0279192 A1 11/2011 Nash et al.

2011/0298559 A1 12/2011 Kitching et al.

2012/0019332 A1 1/2012 Hino et al.

2012/0071123 A1 3/2012 Jones et al.

2012/0243579 A1 9/2012 Premakanthan et al.

2013/0005284 A1 1/2013 Dalipi

2013/0113575 A1 5/2013 Easter

2013/0194054 A1 8/2013 Presti

2013/0207741 A1 8/2013 Presti

2013/0293316 A1 11/2013 Kitching et al.

2013/0307635 A1 11/2013 Kase et al.

2014/0266499 A1 * 9/2014 Noe H01P 5/04
333/111

2014/0368293 A1 12/2014 Mukaiyama

2015/0002239 A1 1/2015 Tanaka

2015/0043669 A1 2/2015 Ell et al.

2015/0200437 A1 7/2015 Solomko et al.

2015/0349742 A1 12/2015 Chen et al.

2016/0028147 A1 1/2016 Srirattana et al.

2016/0028420 A1 1/2016 Srirattana et al.

2016/0043458 A1 2/2016 Sun et al.

2016/0065167 A1 * 3/2016 Granger-Jones H01F 38/14
333/112

2016/0079649 A1 * 3/2016 Ilkov H03H 7/383
343/853

2016/0079650 A1 * 3/2016 Solomko H03H 7/48
333/103

2016/0172737 A1 * 6/2016 Srirattana H01P 5/184
333/111

2016/0172738 A1 6/2016 Srirattana et al.

2016/0172739 A1 * 6/2016 Srirattana H01P 5/184
333/111

2016/0172740 A1 * 6/2016 Srirattana H01P 5/184
333/111

FOREIGN PATENT DOCUMENTS

JP 2000-077915 A 3/2000

JP 2001127664 A 5/2001

JP 2013126067 A * 6/2013 H04B 1/40

KR 20040037465 A 5/2004

KR 20110118289 A 10/2011

WO 2005018451 A1 3/2005

WO 2015020927 A2 2/2015

OTHER PUBLICATIONS

International Search Report and Written Opinion from corresponding PCT Application No. PCT/US2015/064444 dated Jun. 6, 2016.

* cited by examiner

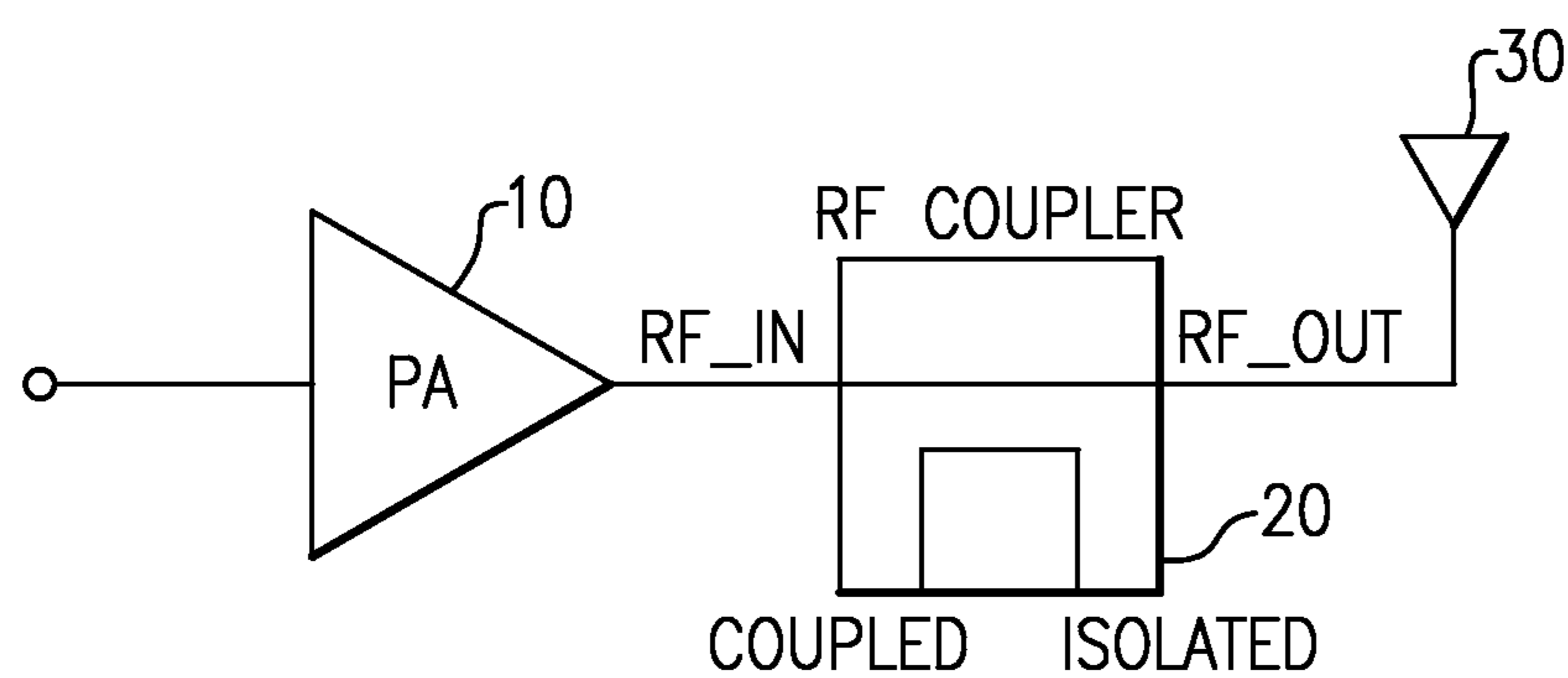

FIG.1

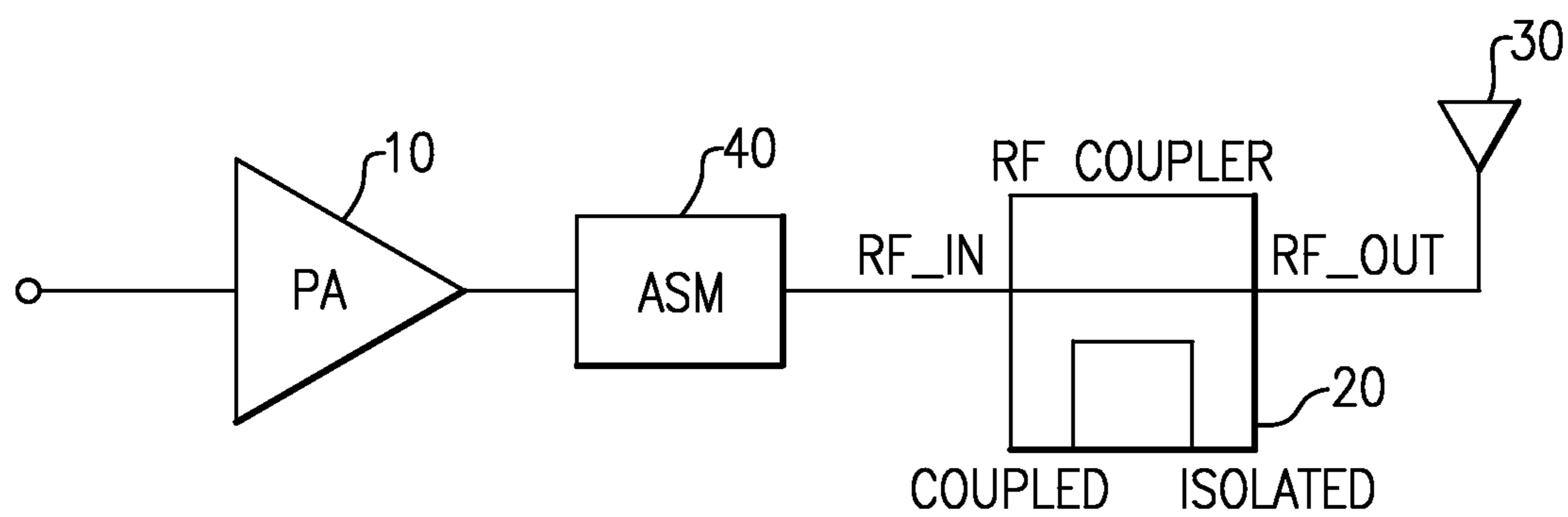

FIG.2

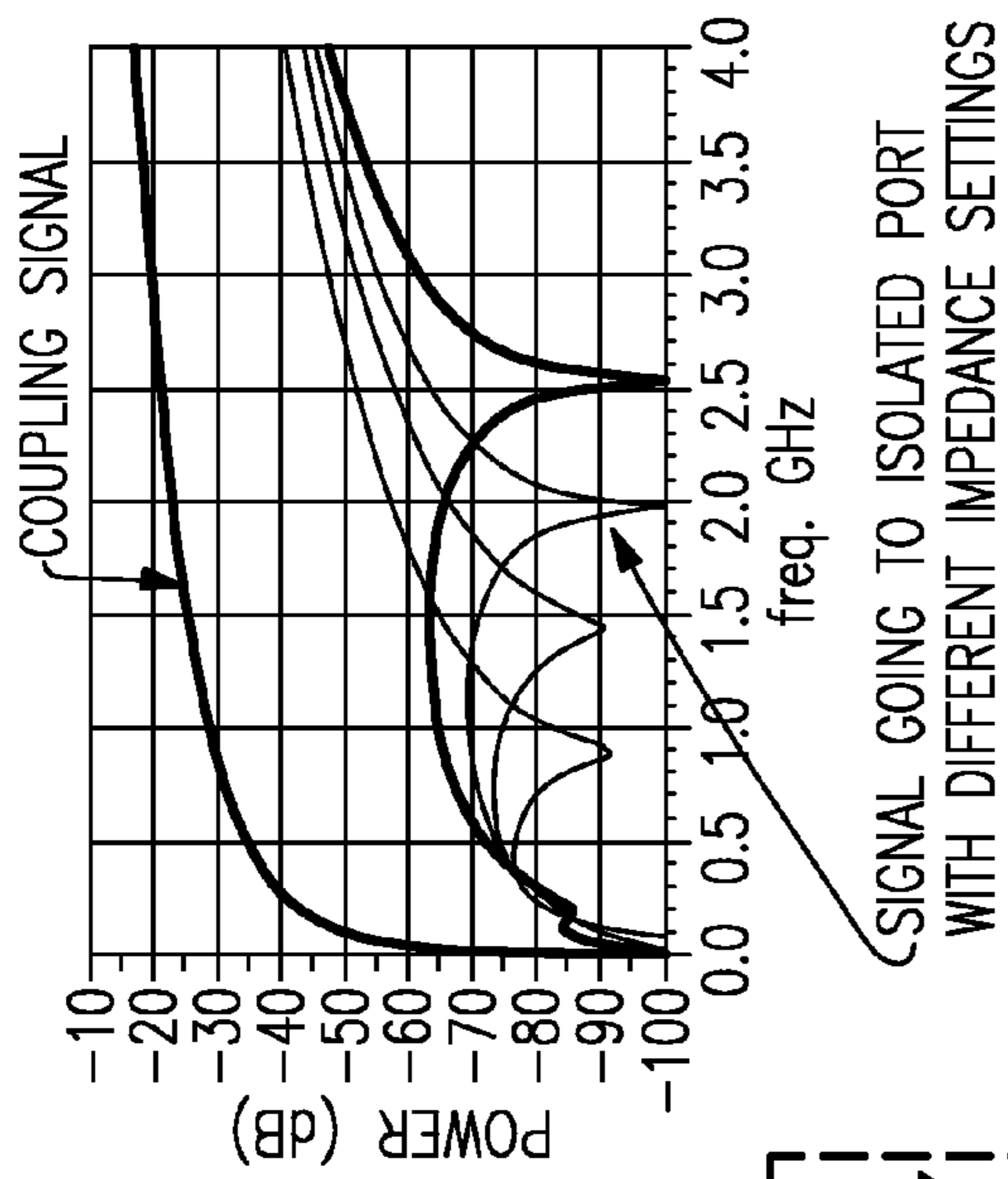

FIG. 3B

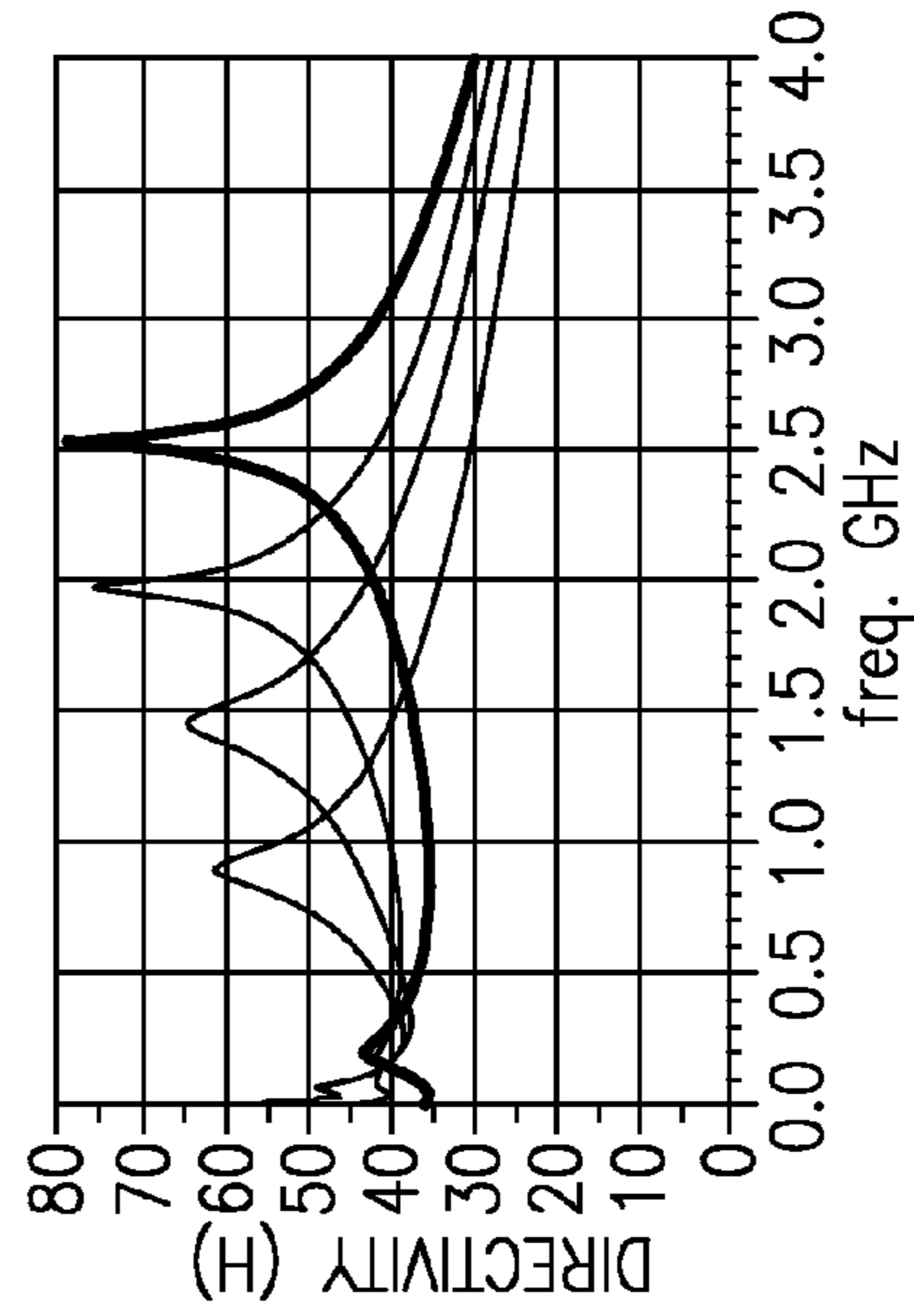

FIG. 3C

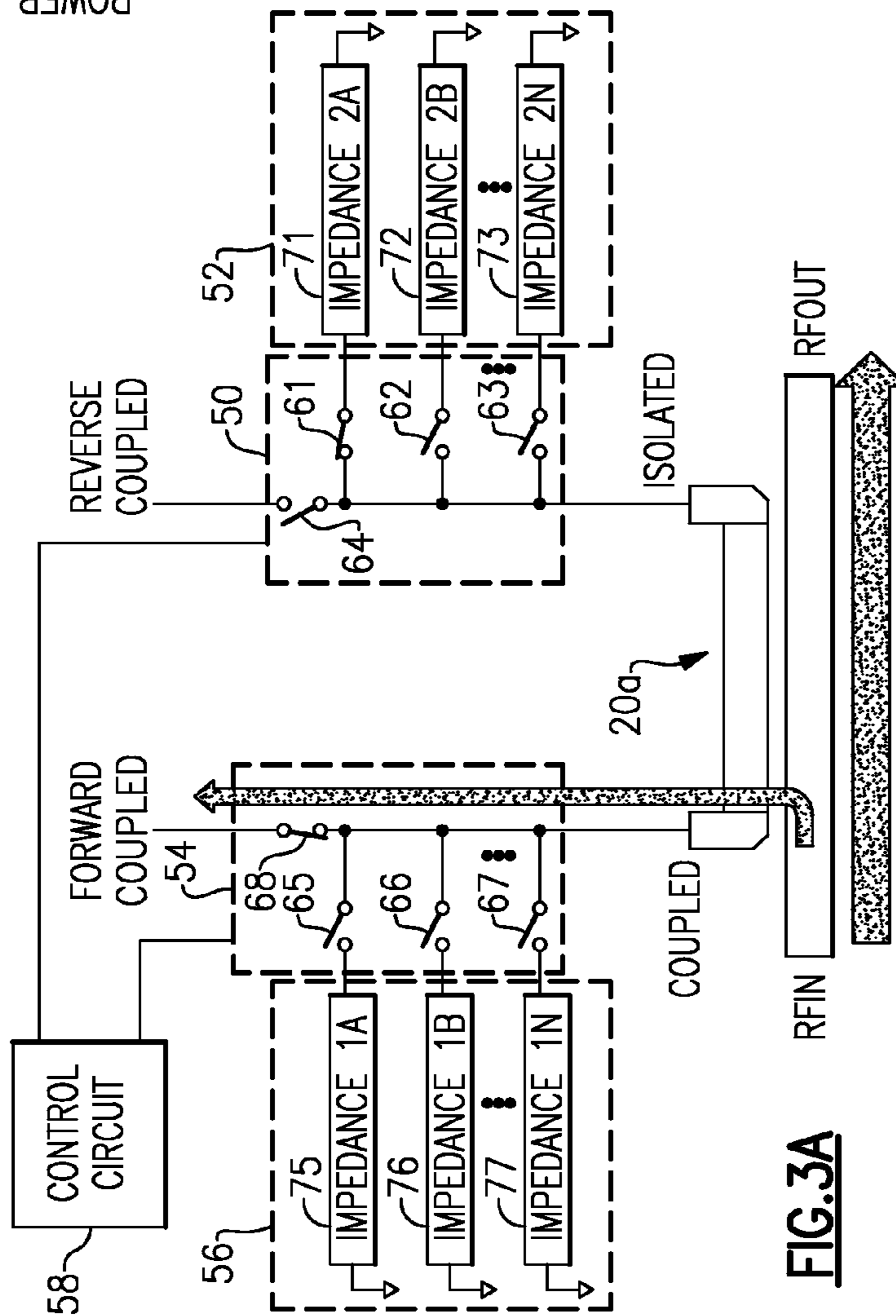

FIG. 3A

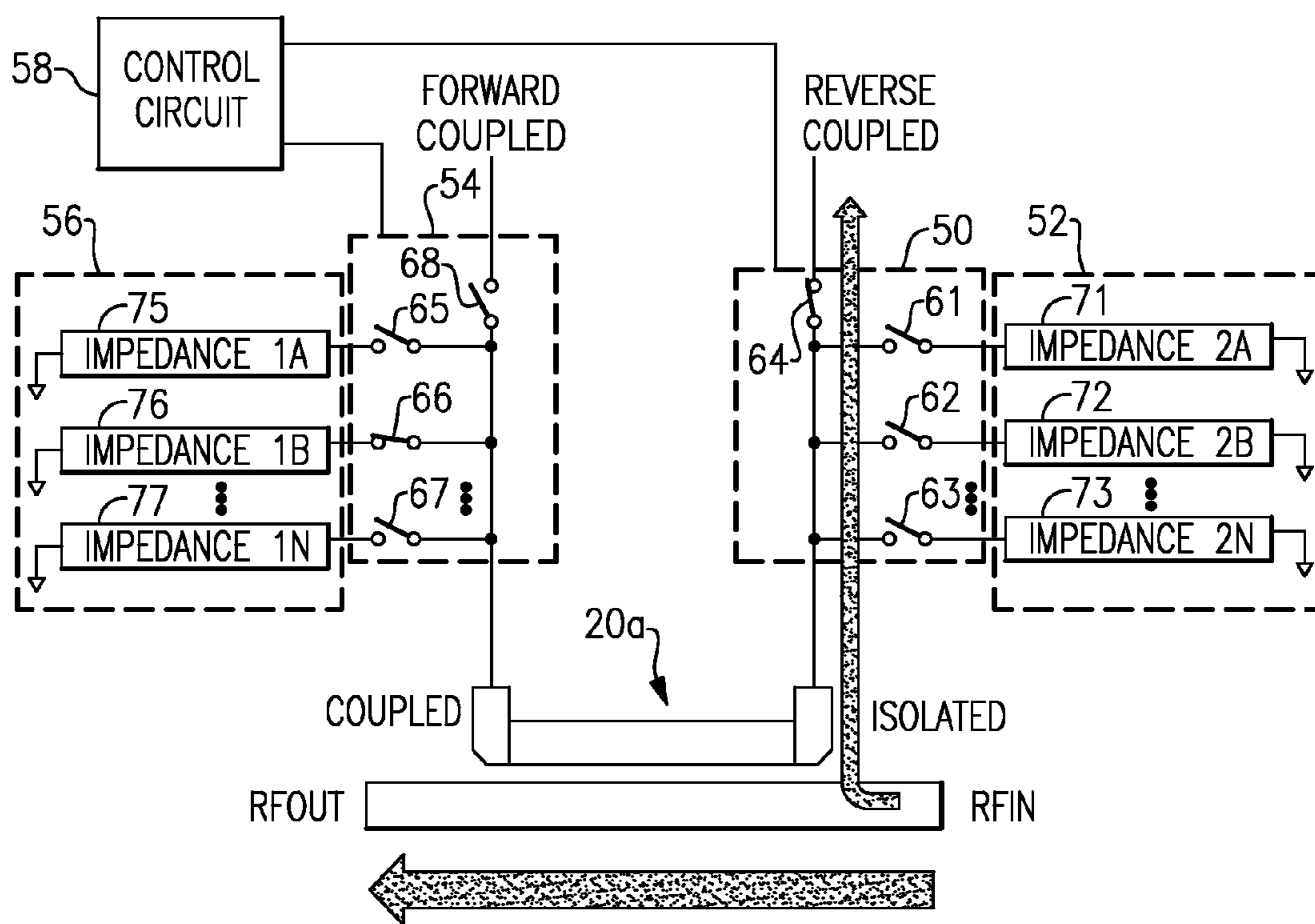

FIG. 4

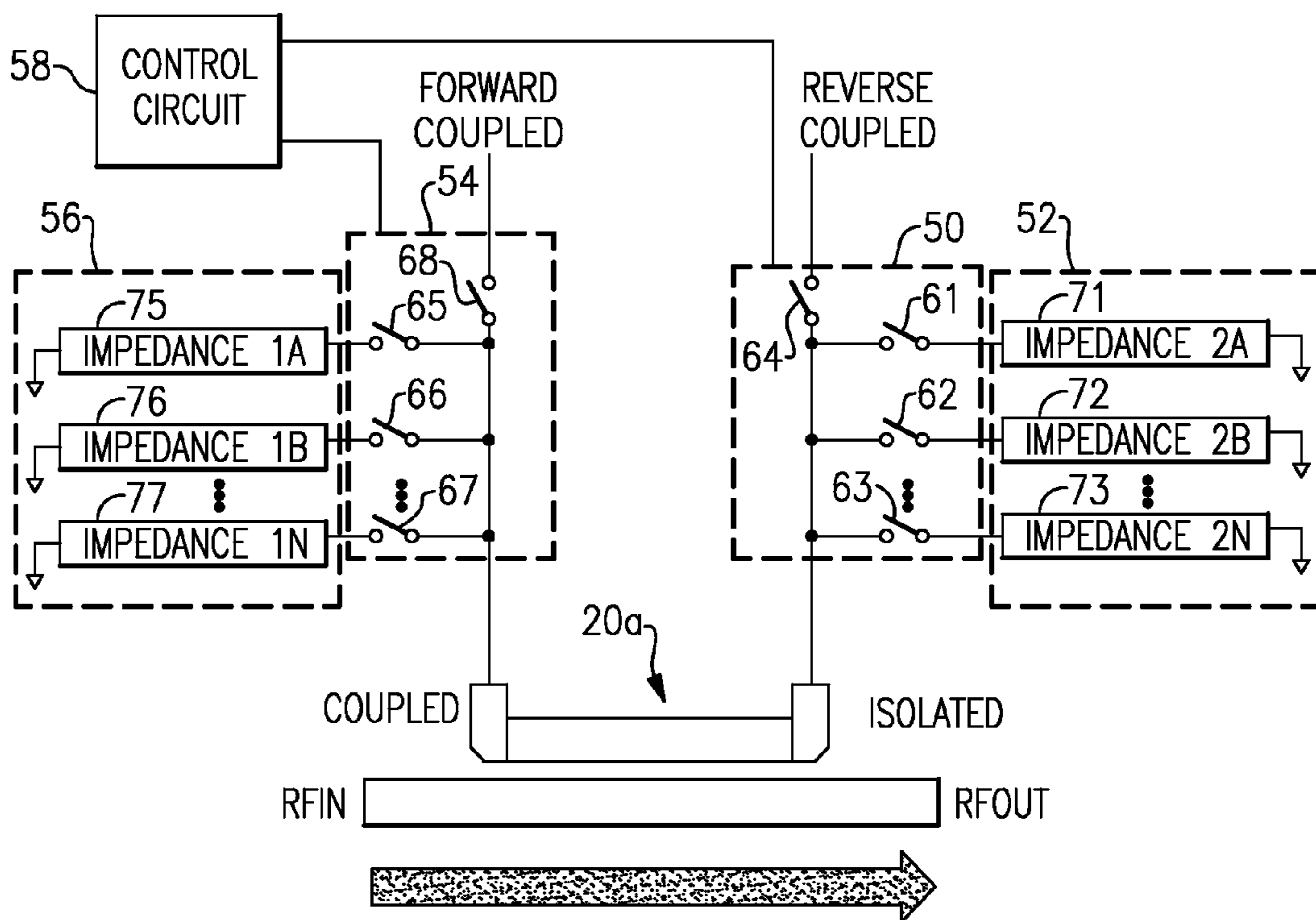

FIG. 5

FIG. 6A

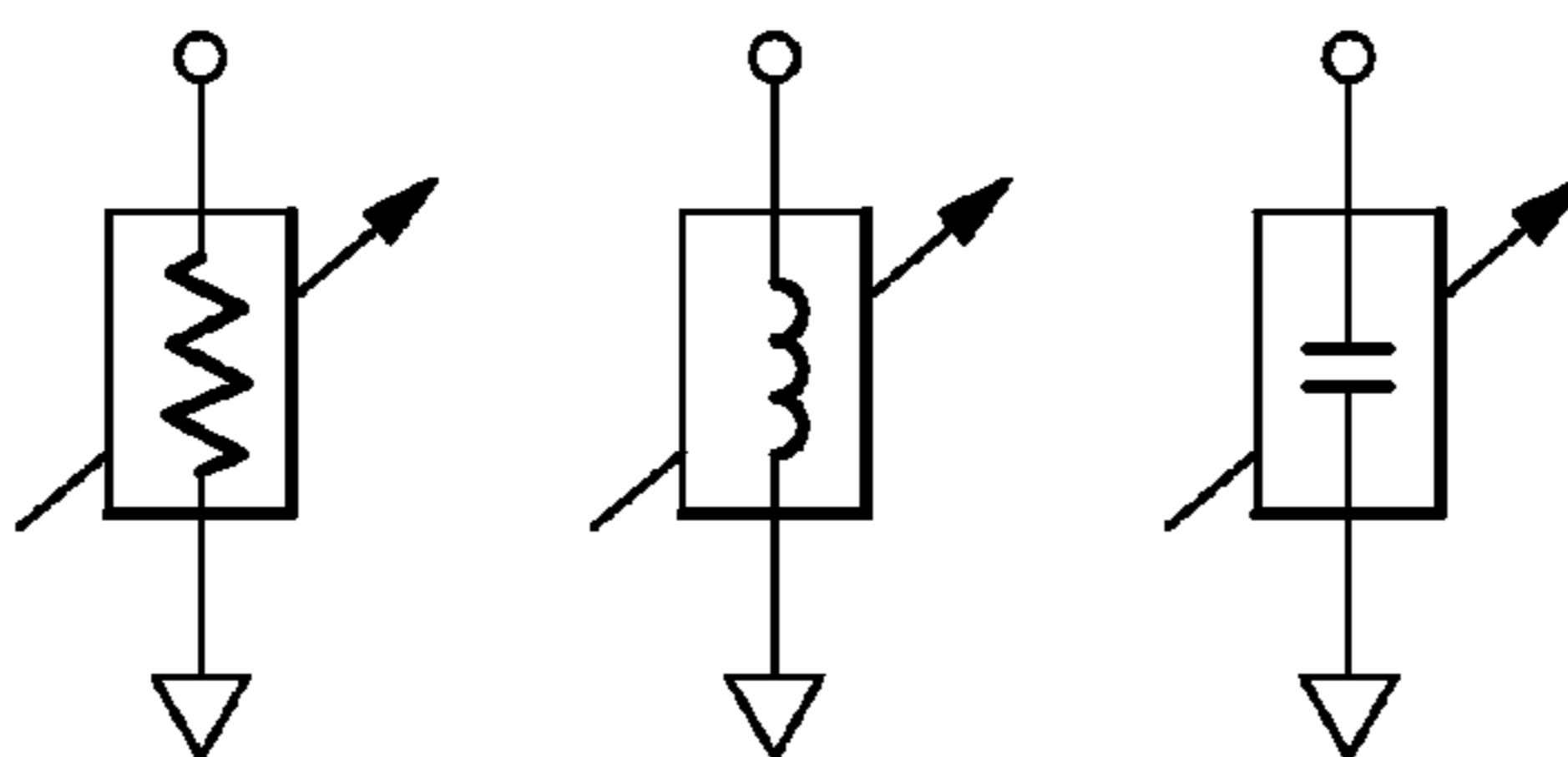
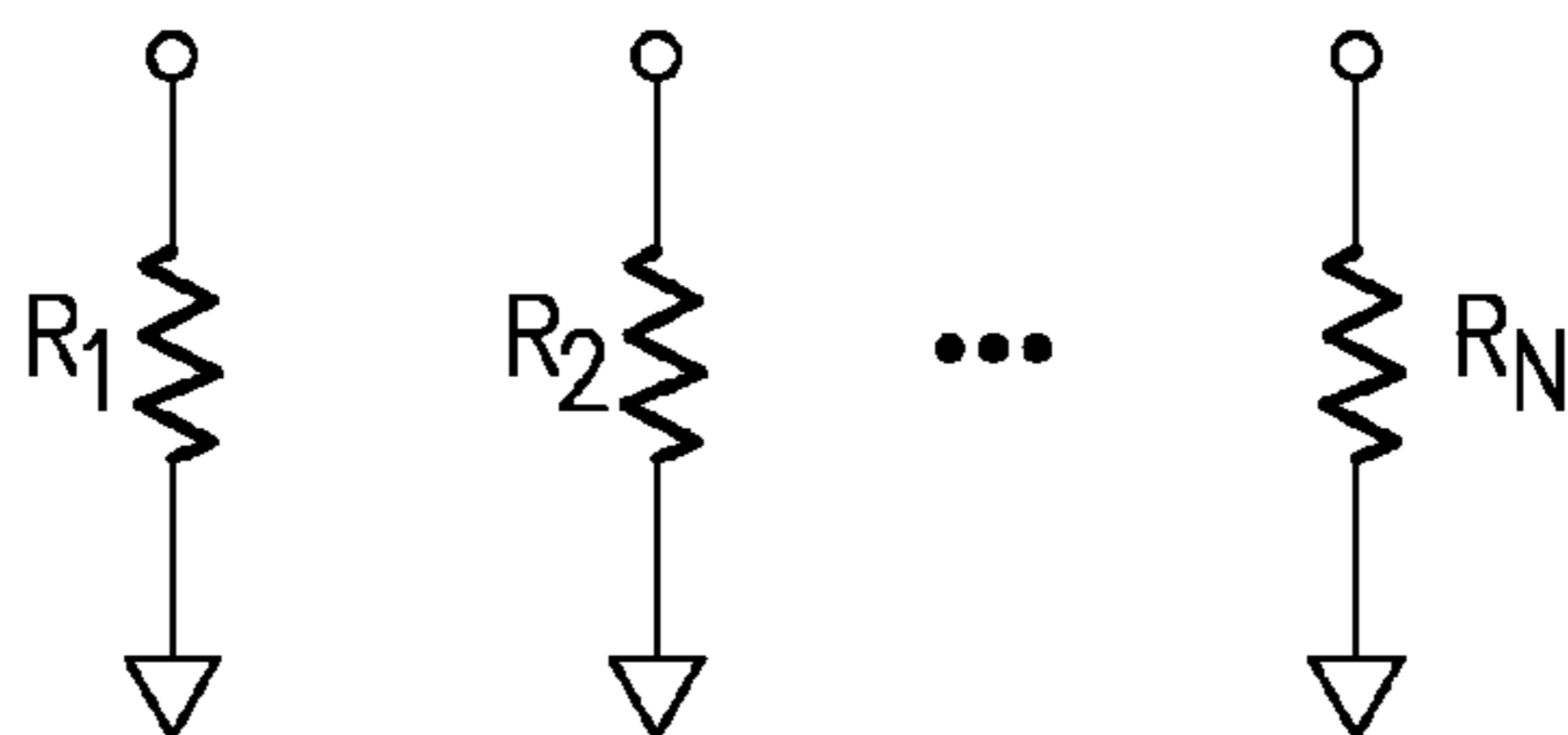
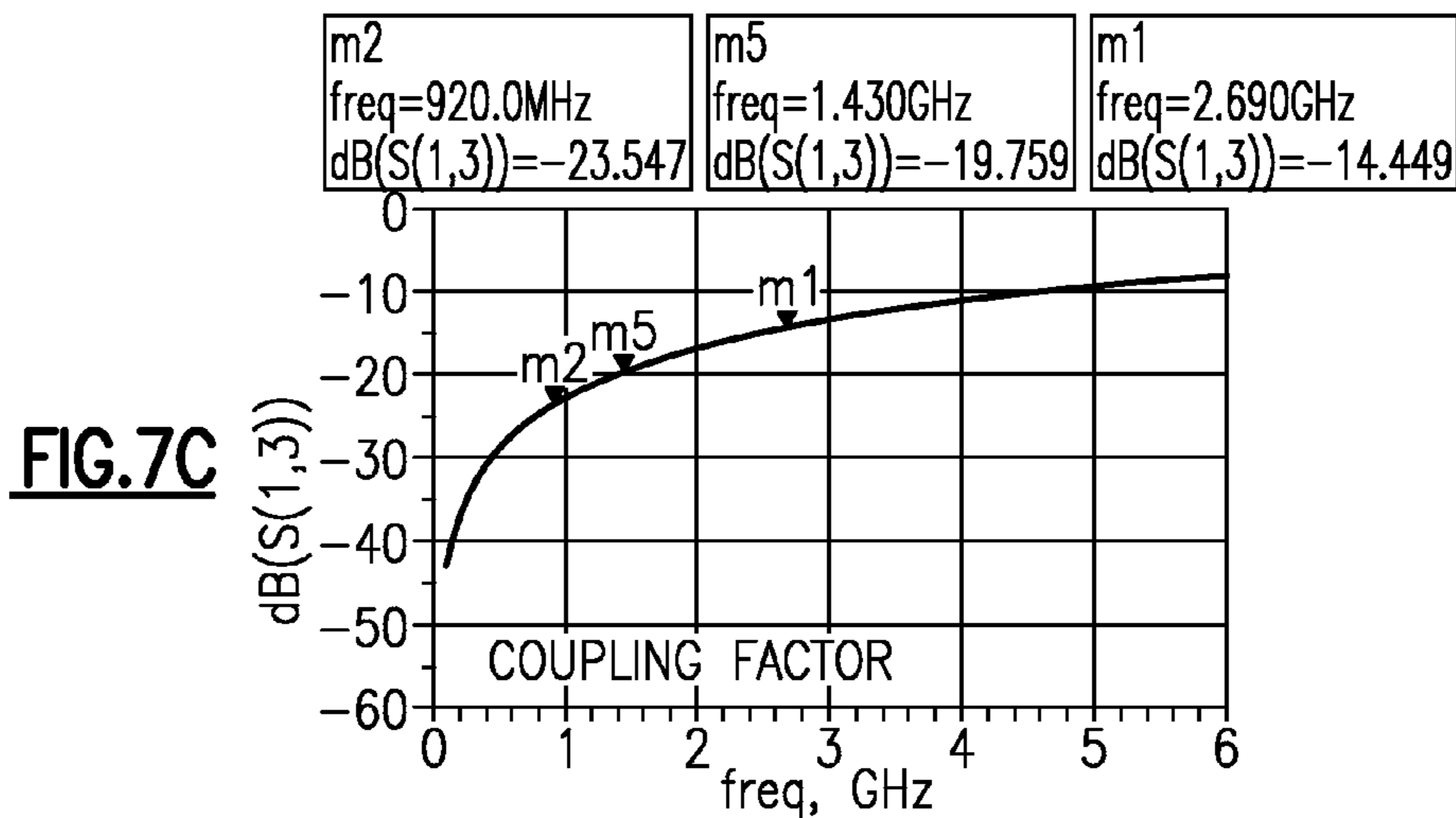
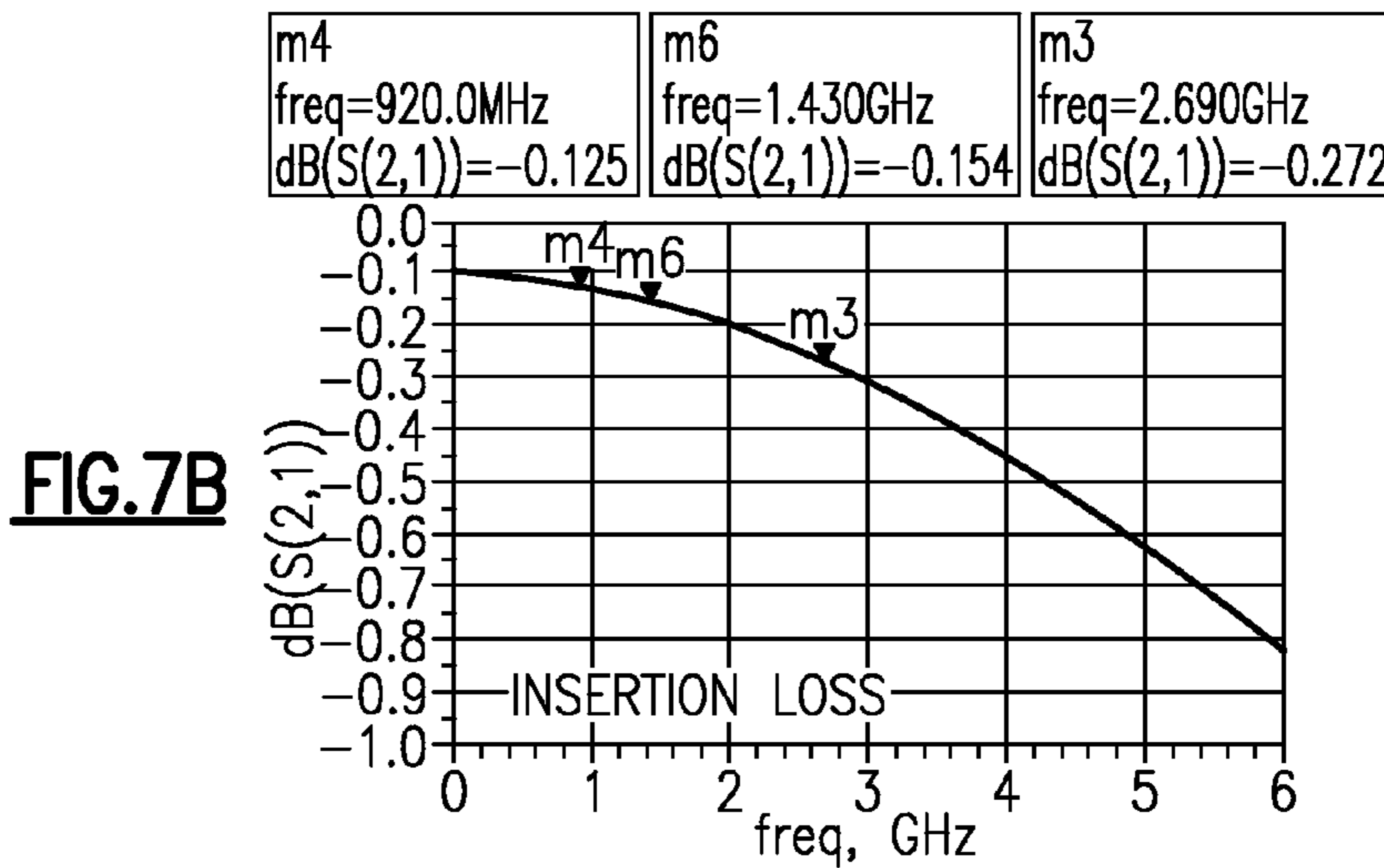
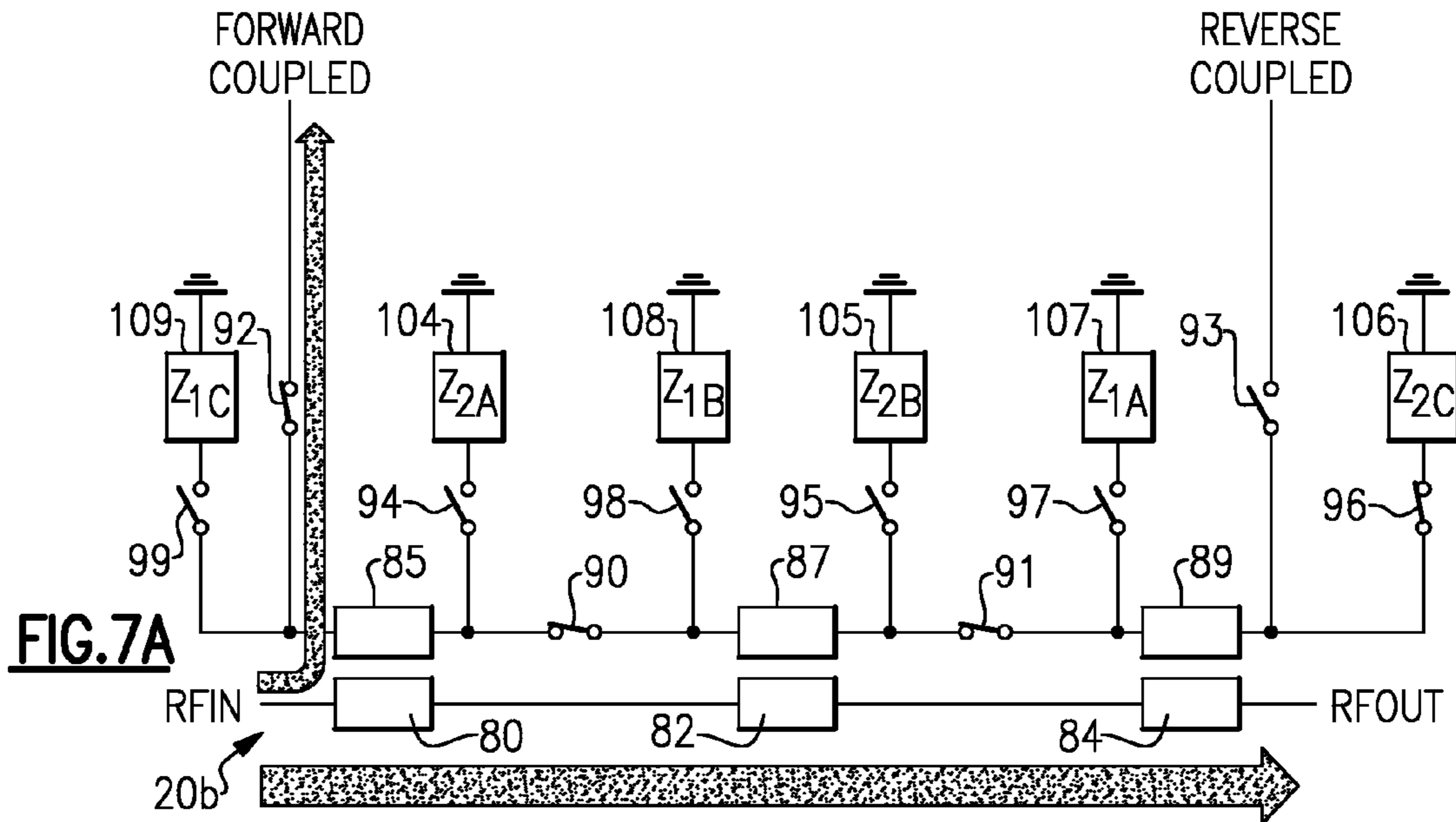
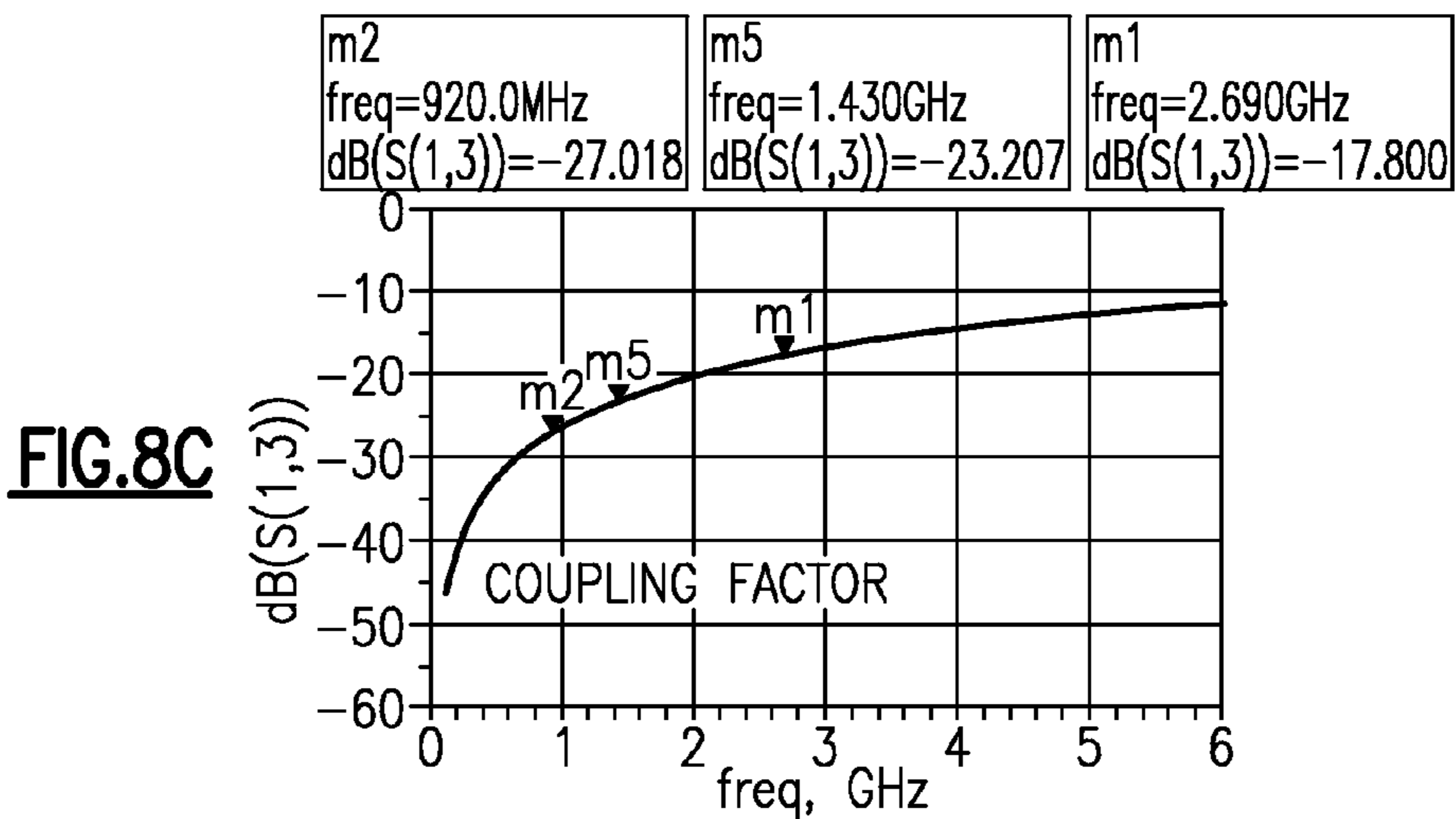
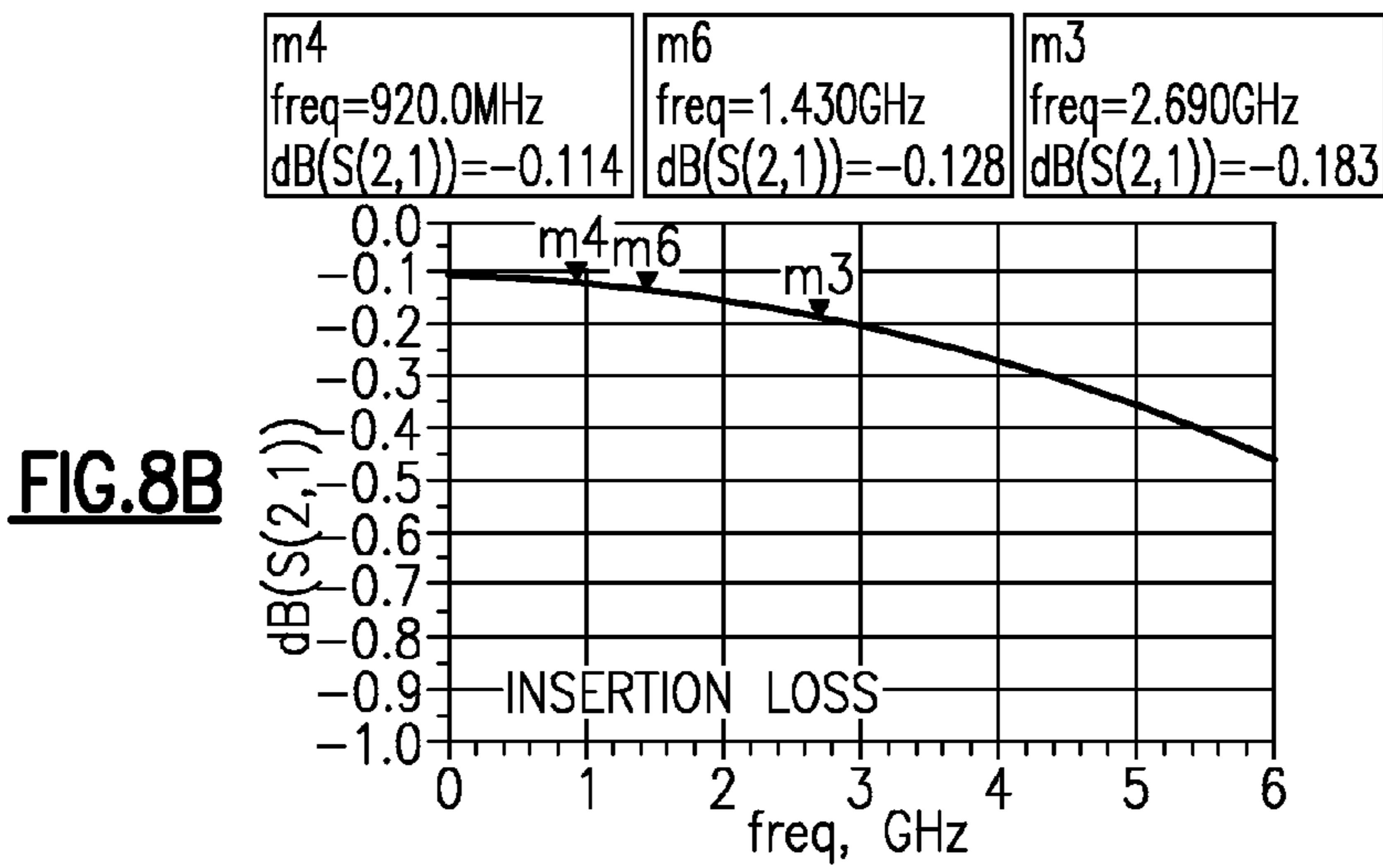
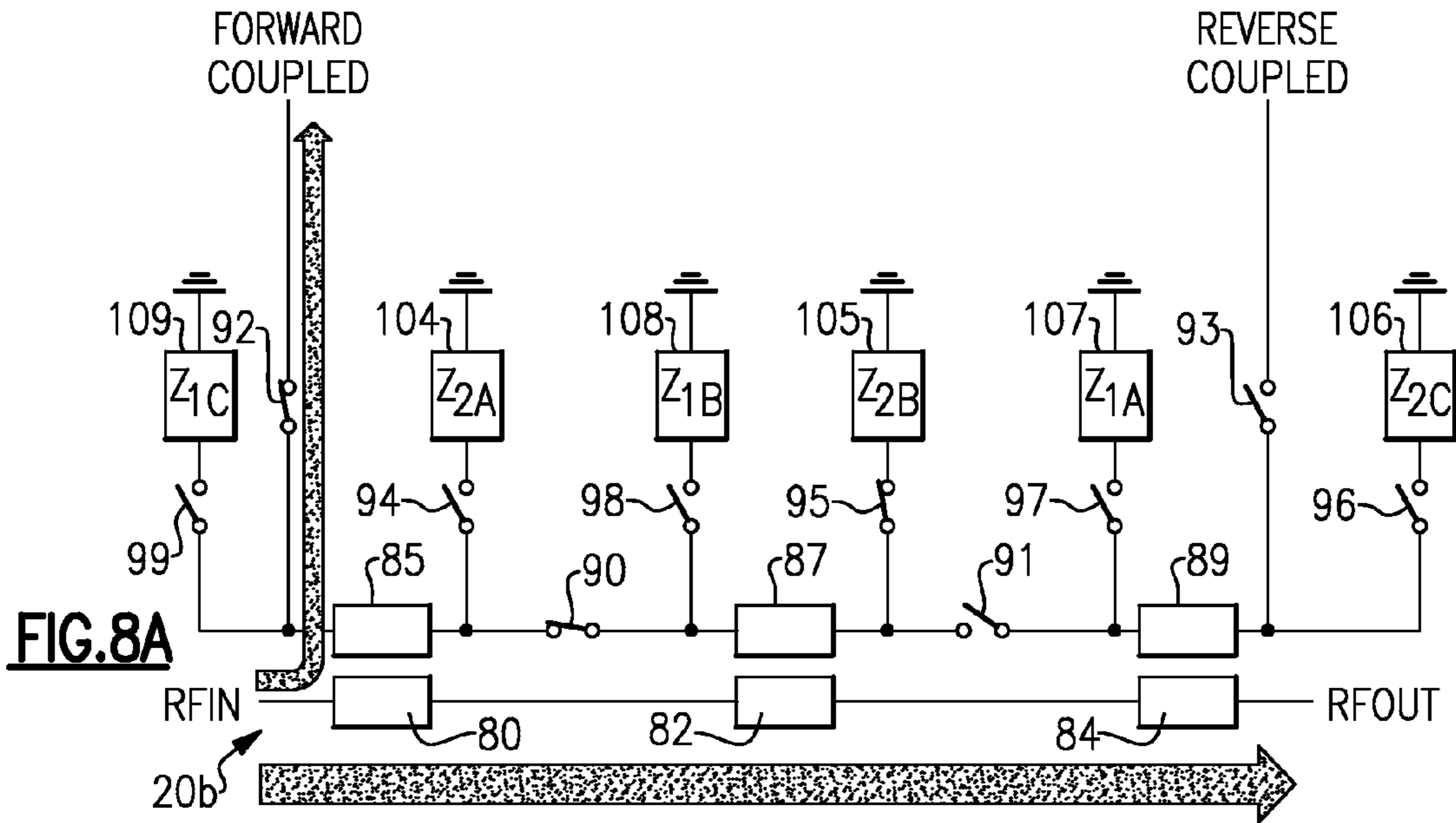

FIG. 6B







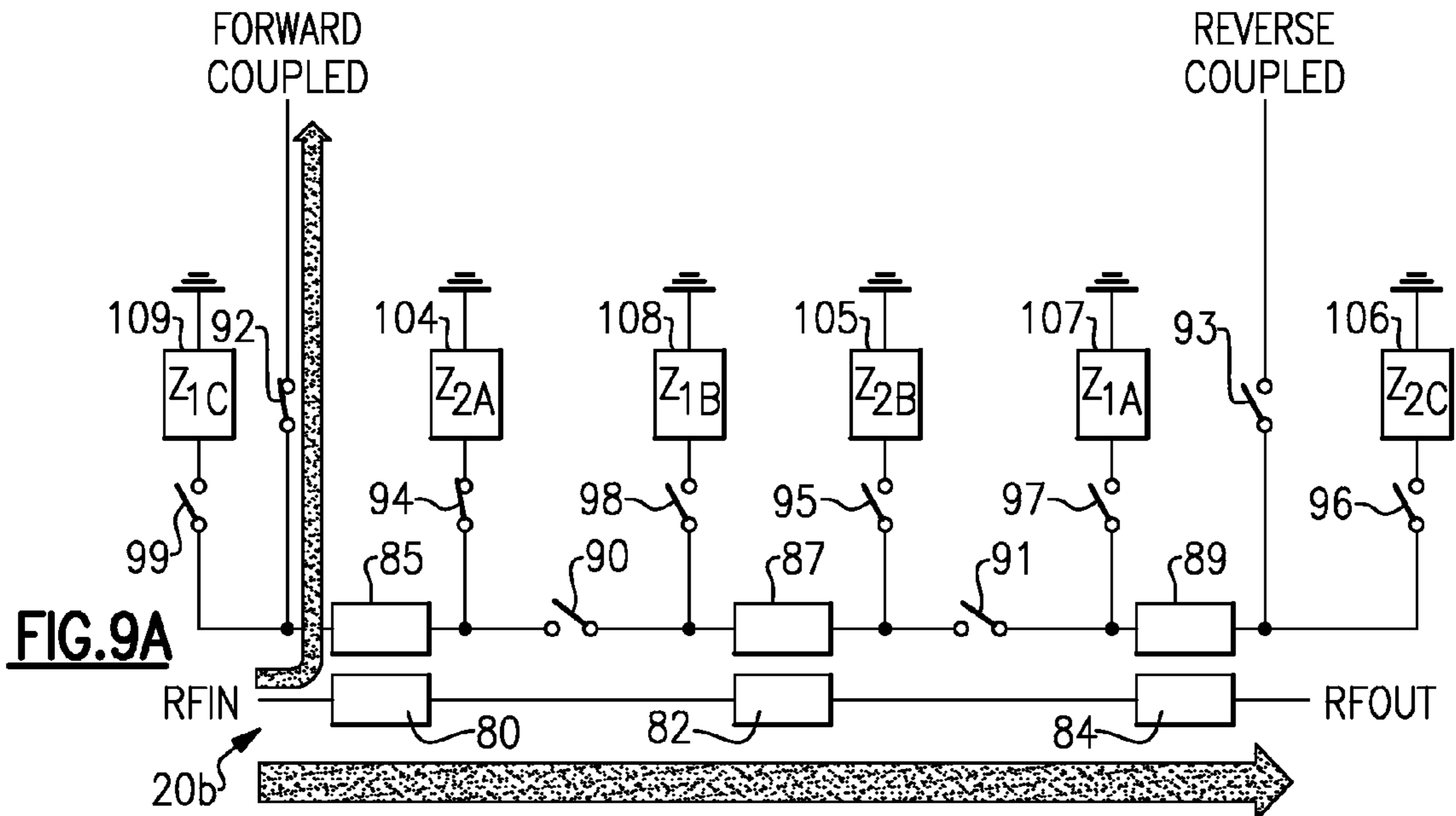

FIG. 9B

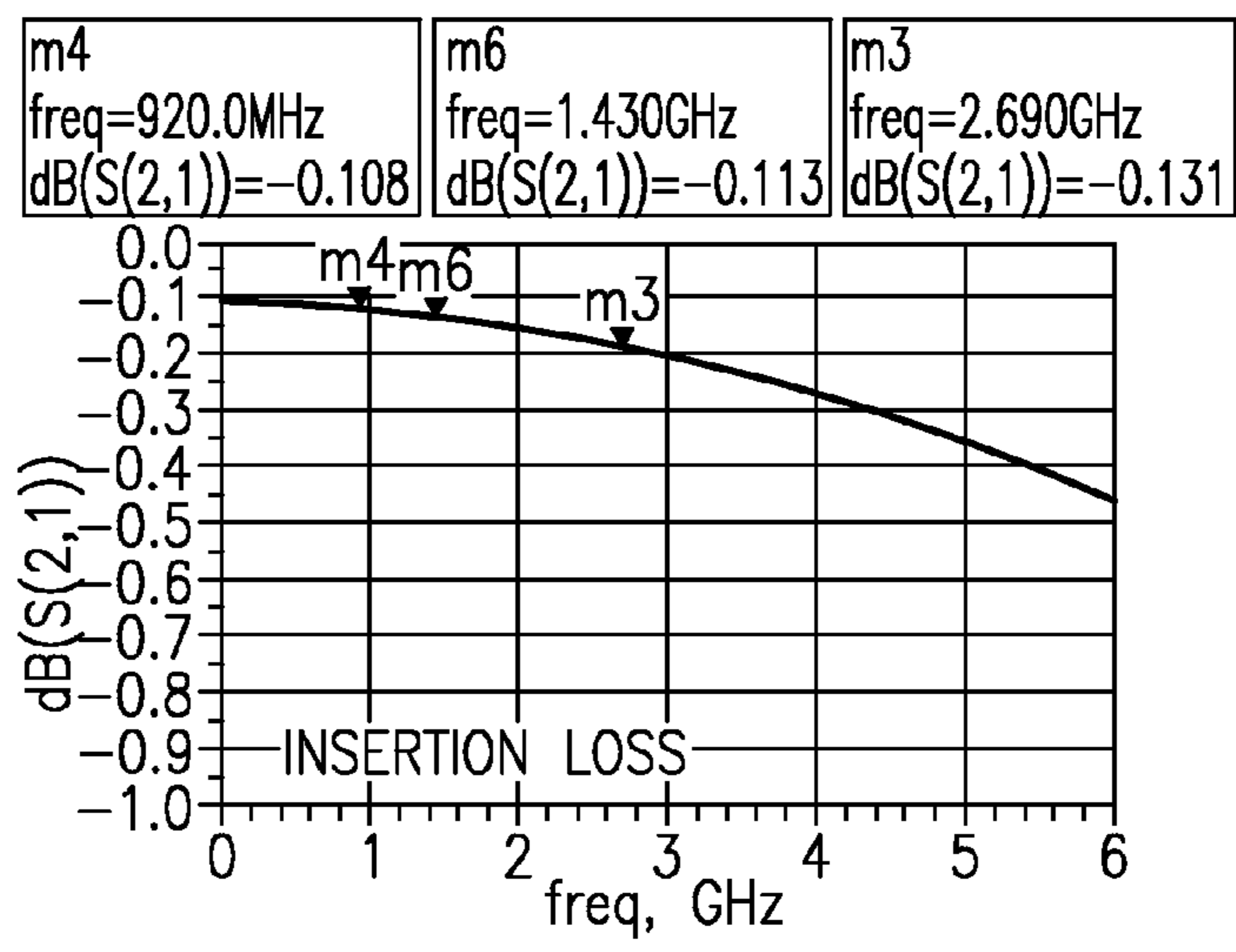
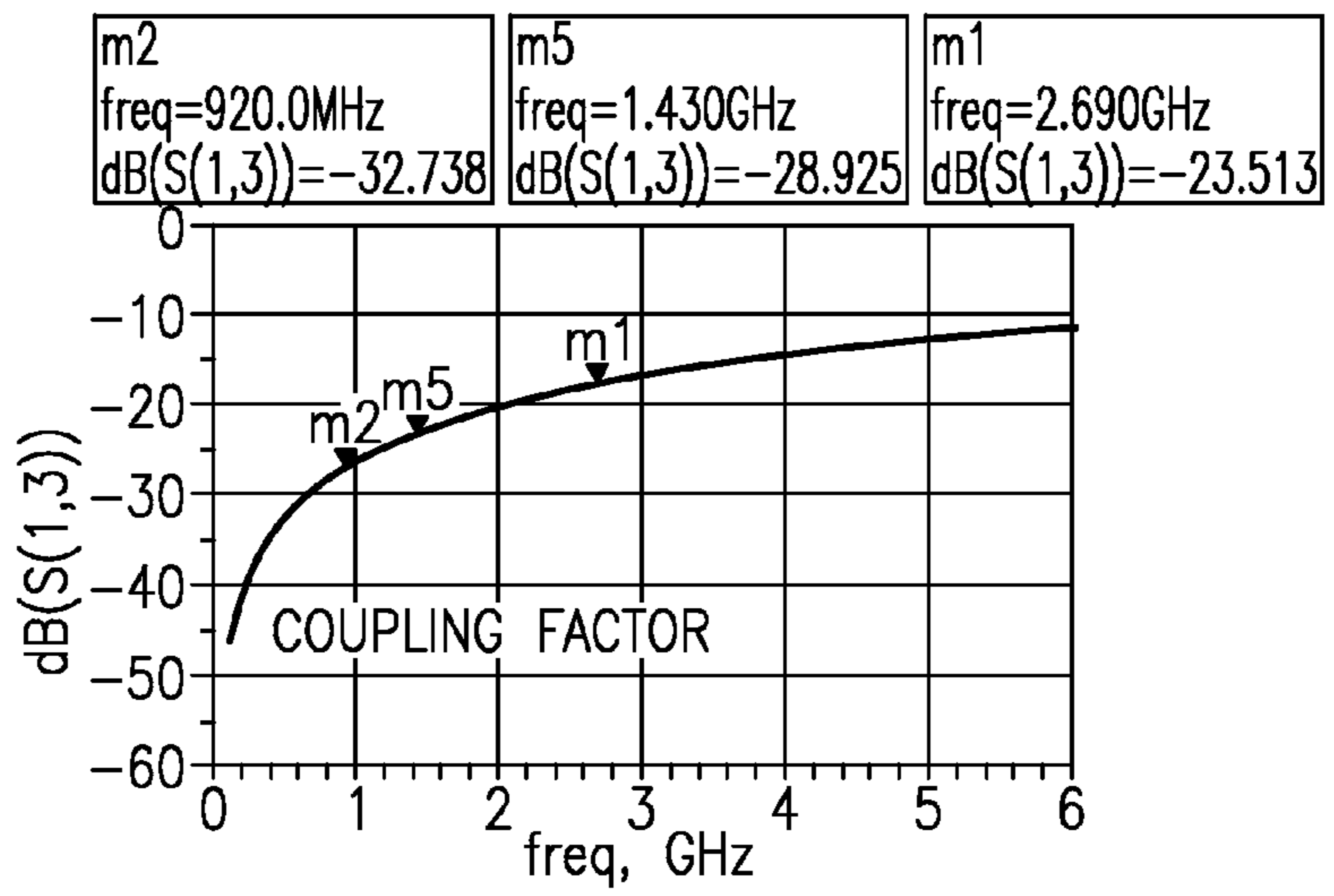

FIG. 9C



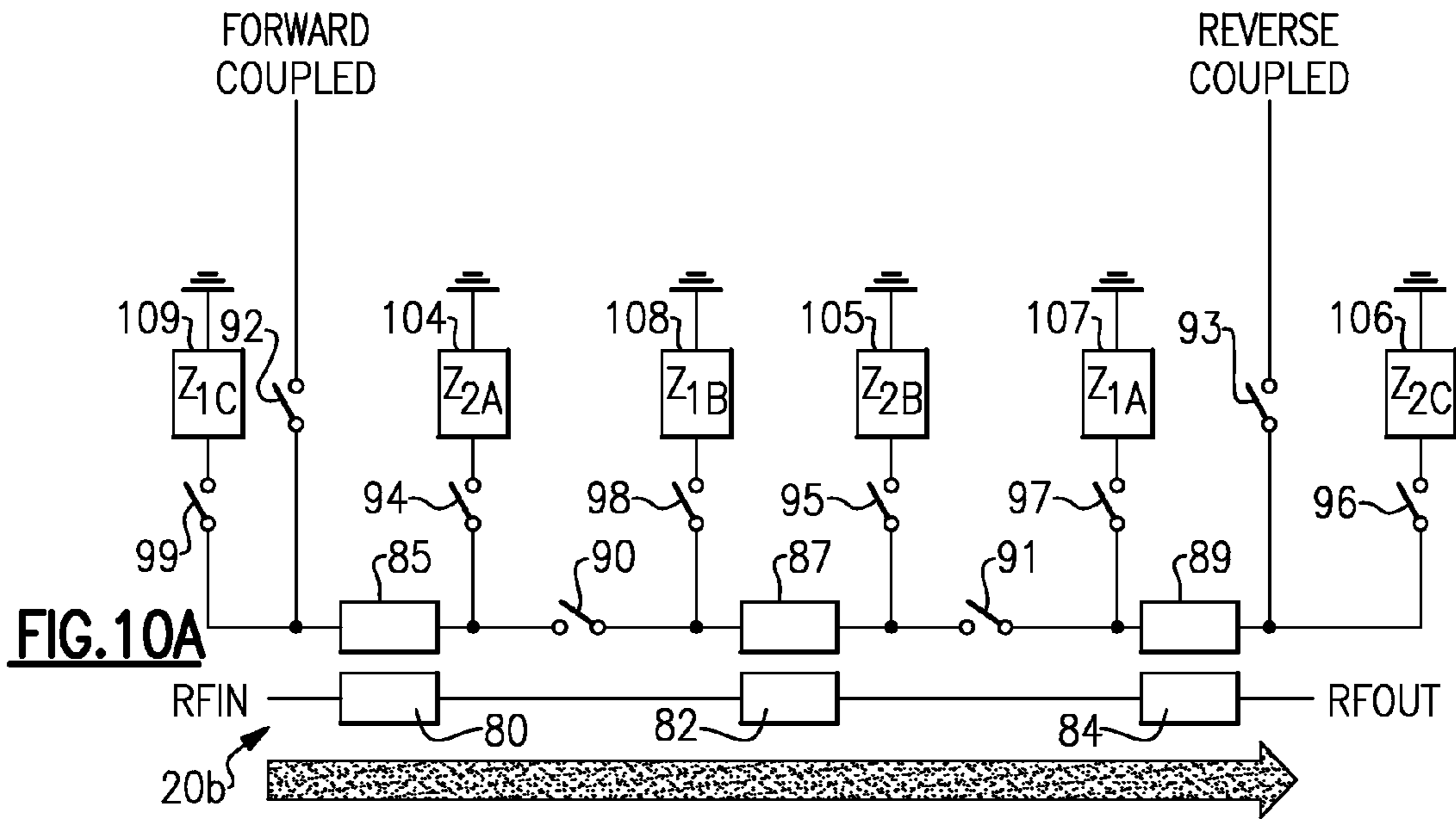
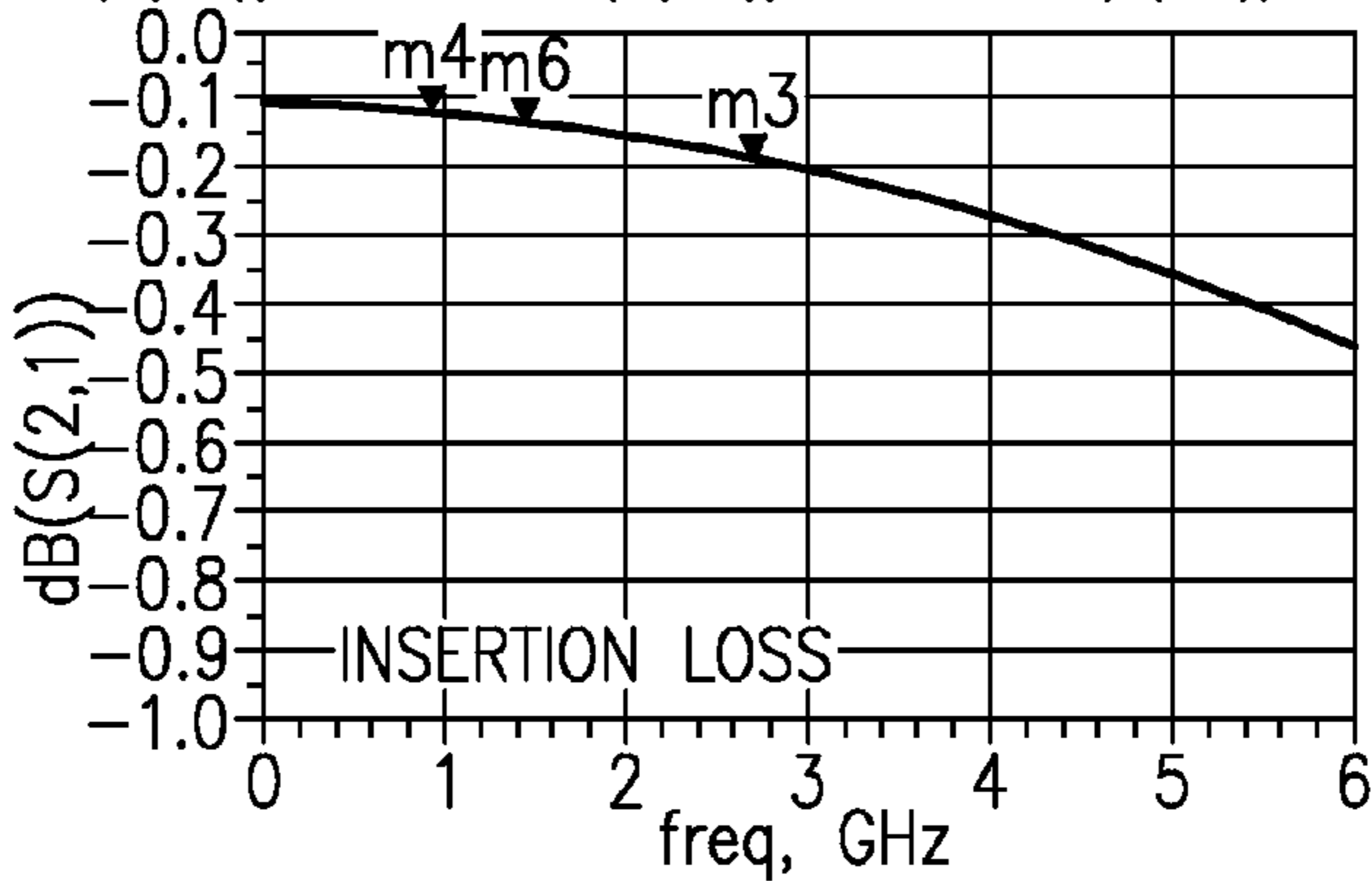

FIG. 10A

| | | |
|--|--|--|
| m4 freq=920.0MHz dB(S(2,1))=-0.106 | m6 freq=1.430GHz dB(S(2,1))=-0.109 | m3 freq=2.690GHz dB(S(2,1))=-0.116 |
|--|--|--|

FIG. 10B



| | | |
|--|--|--|
| m2 freq=920.0MHz dB(S(1,3))=-100.097 | m5 freq=1.430GHz dB(S(1,3))=-100.079 | m1 freq=2.690GHz dB(S(1,3))=-100.008 |
|--|--|--|

FIG. 10C

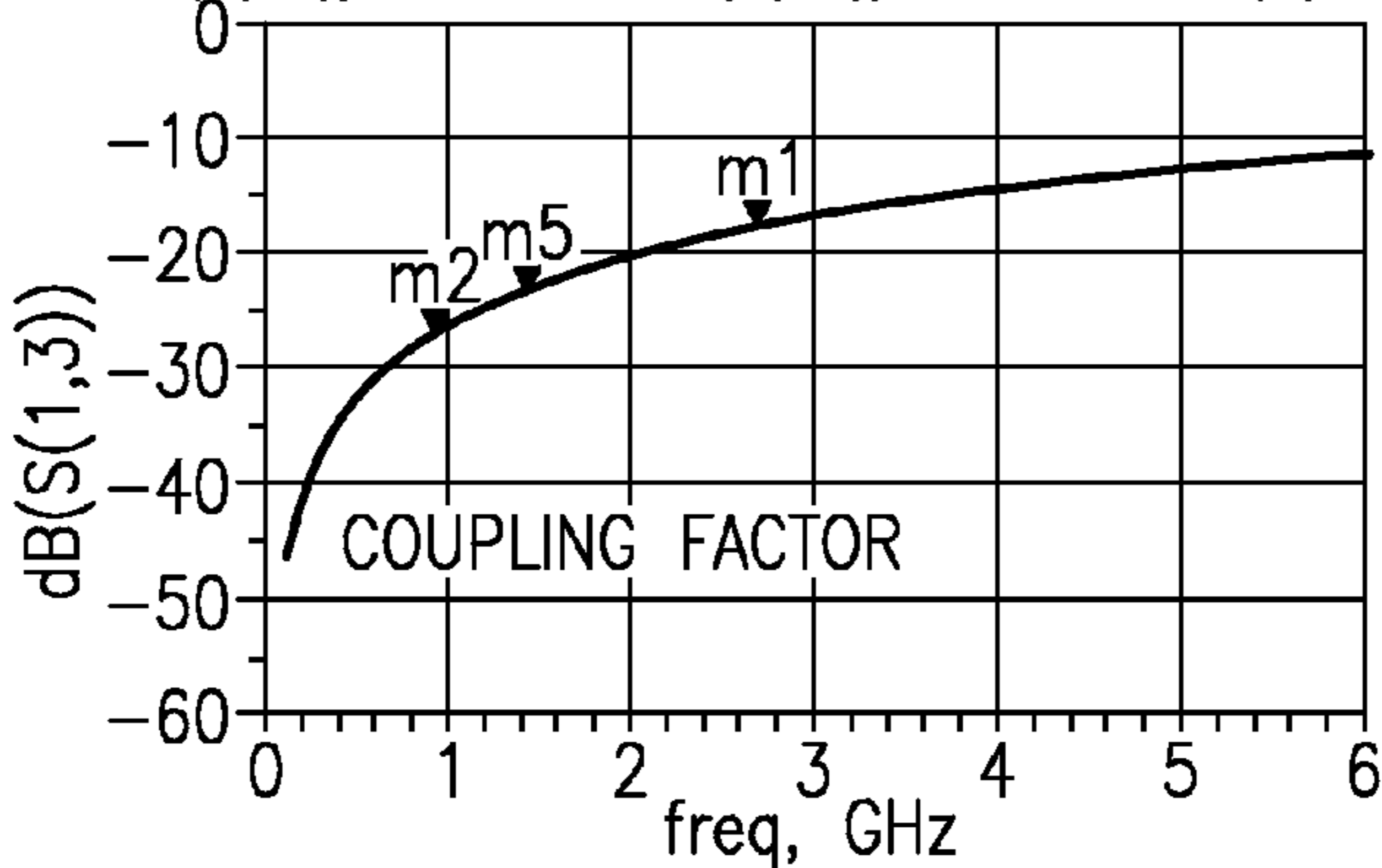

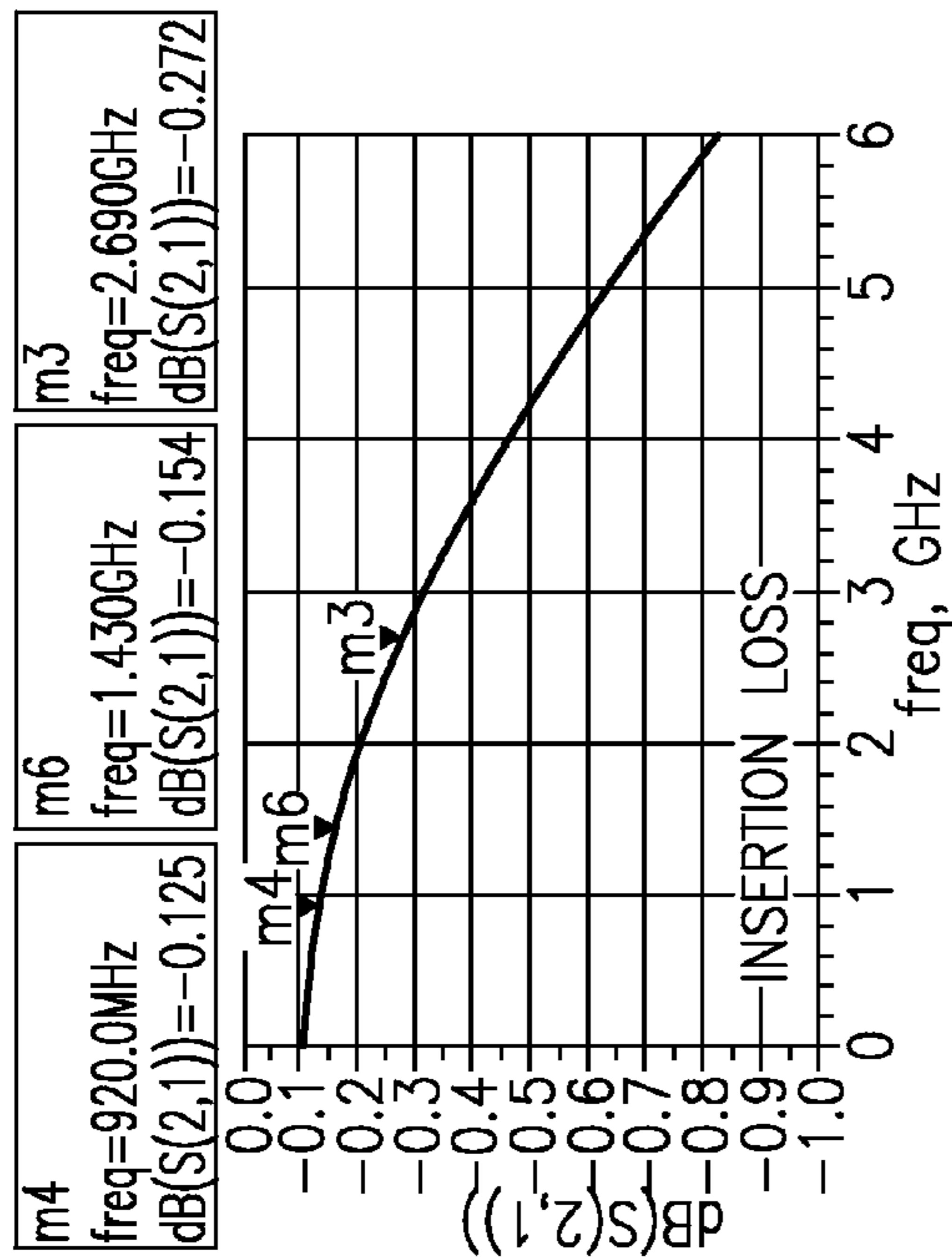

FIG.11A

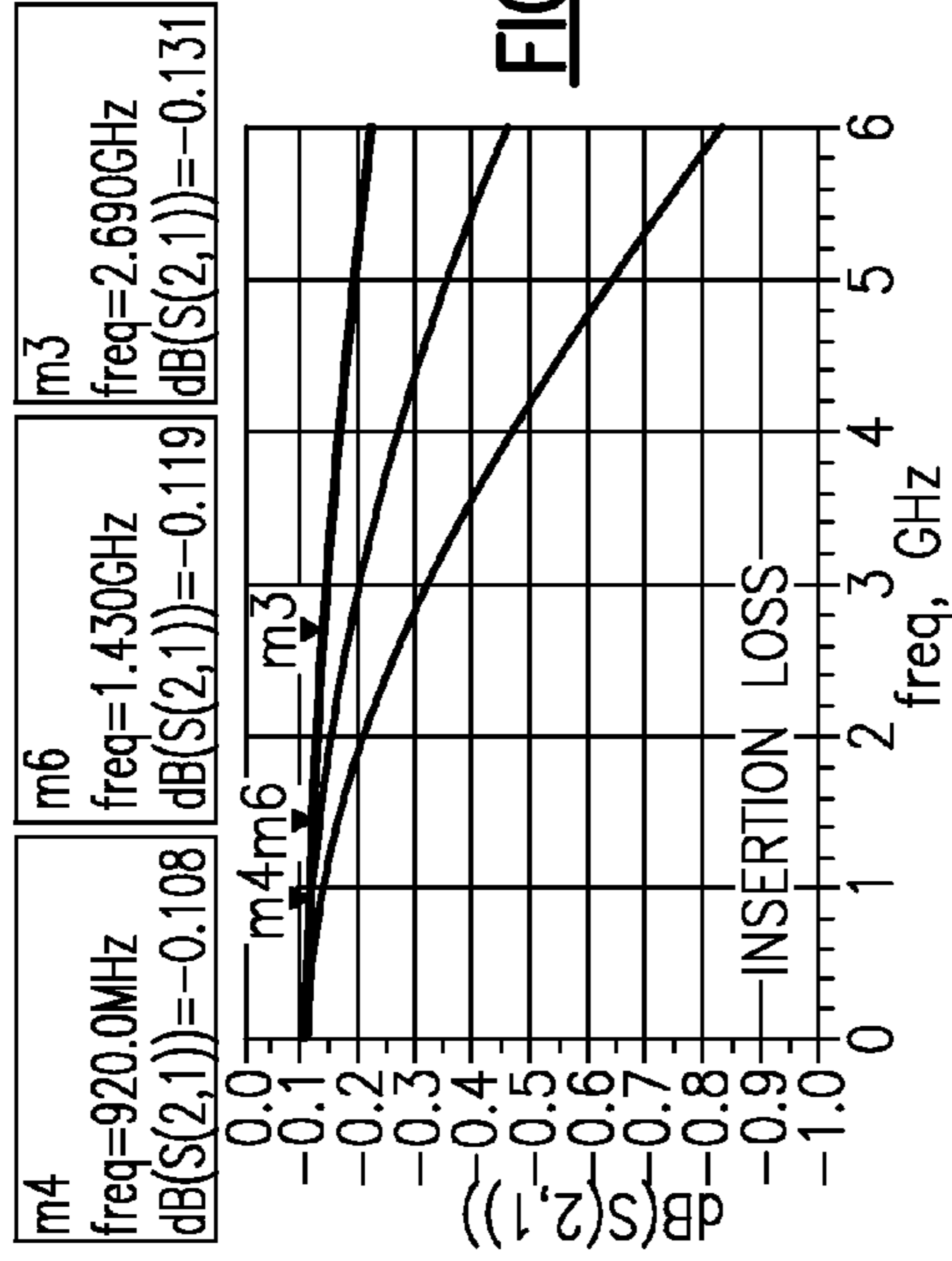

FIG.11B

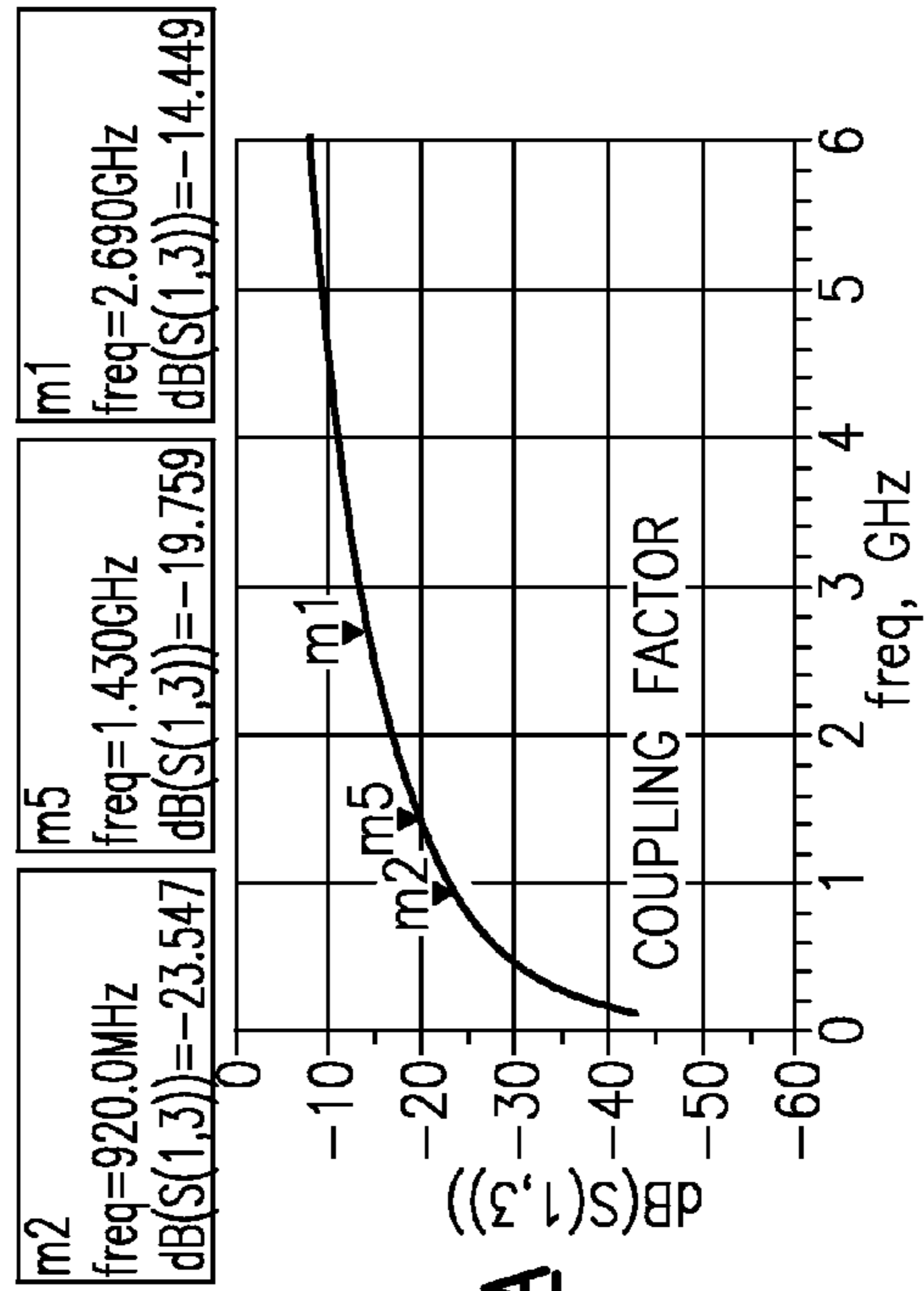

FIG12A

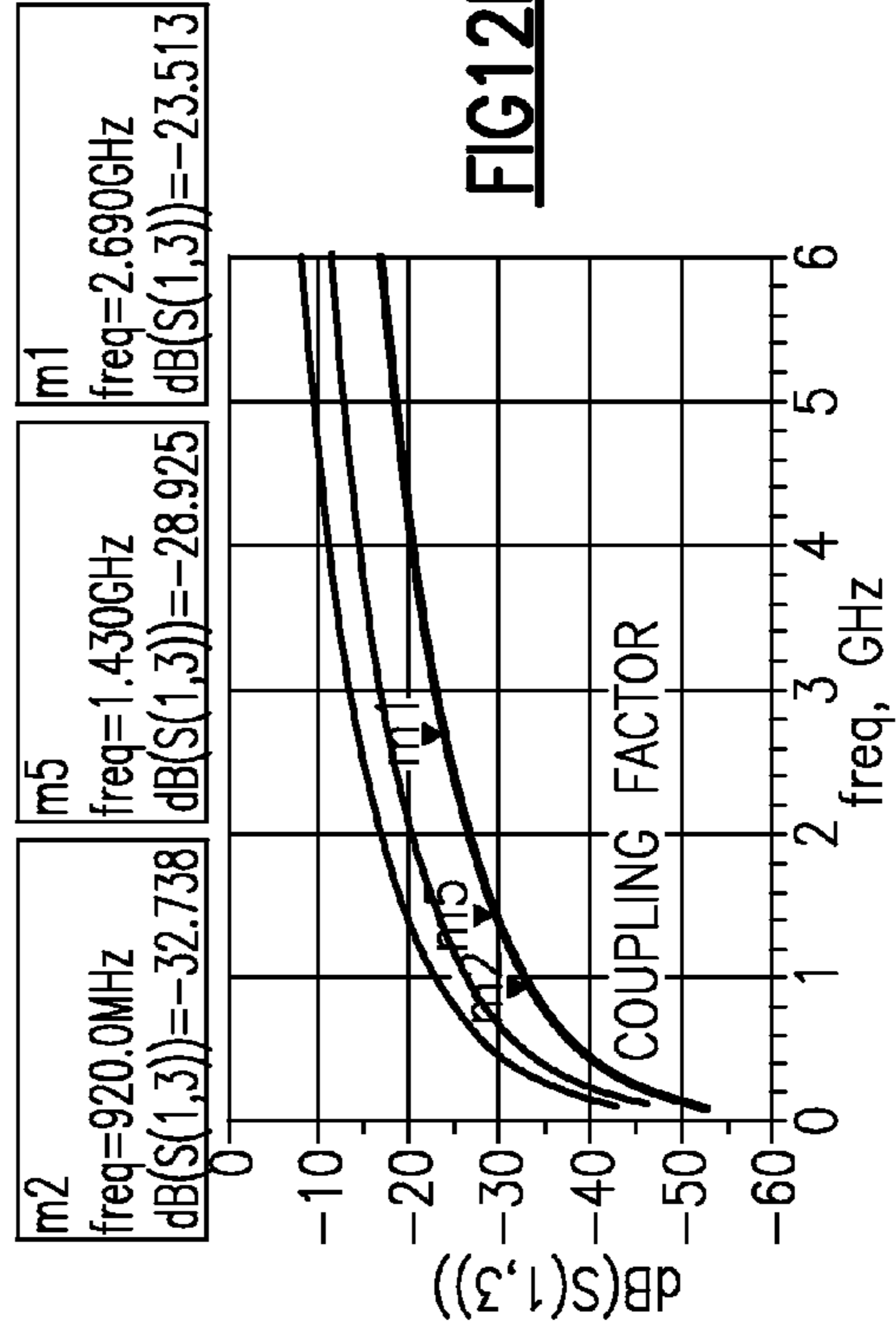

FIG12B

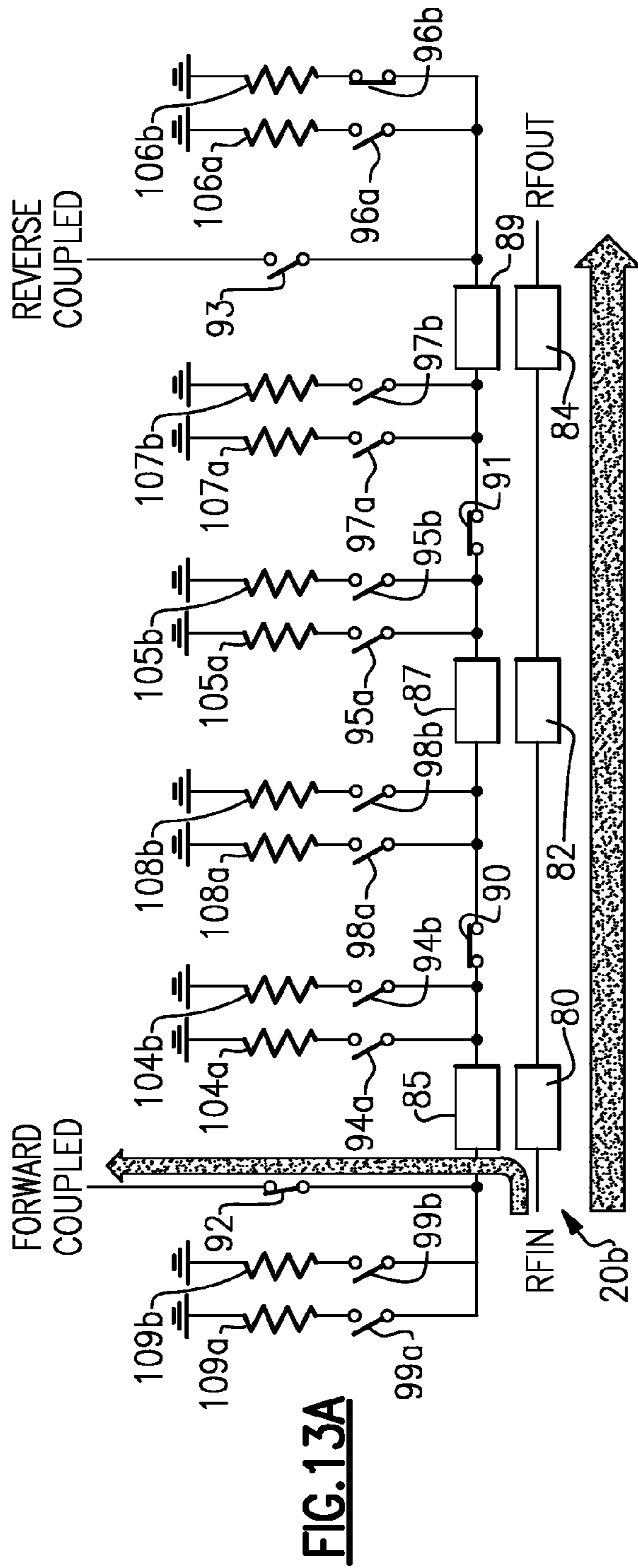

FIG. 13A

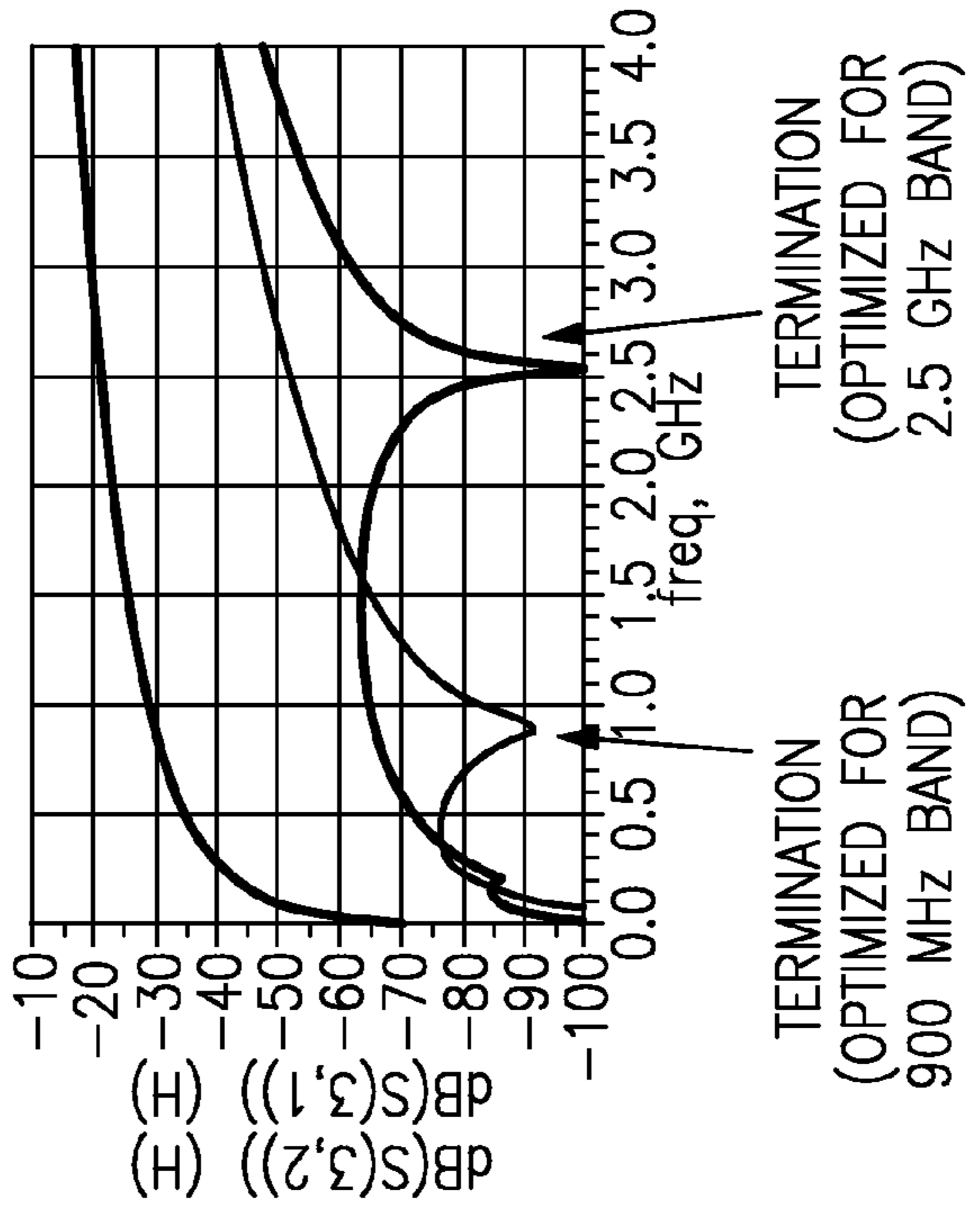

FIG. 13B

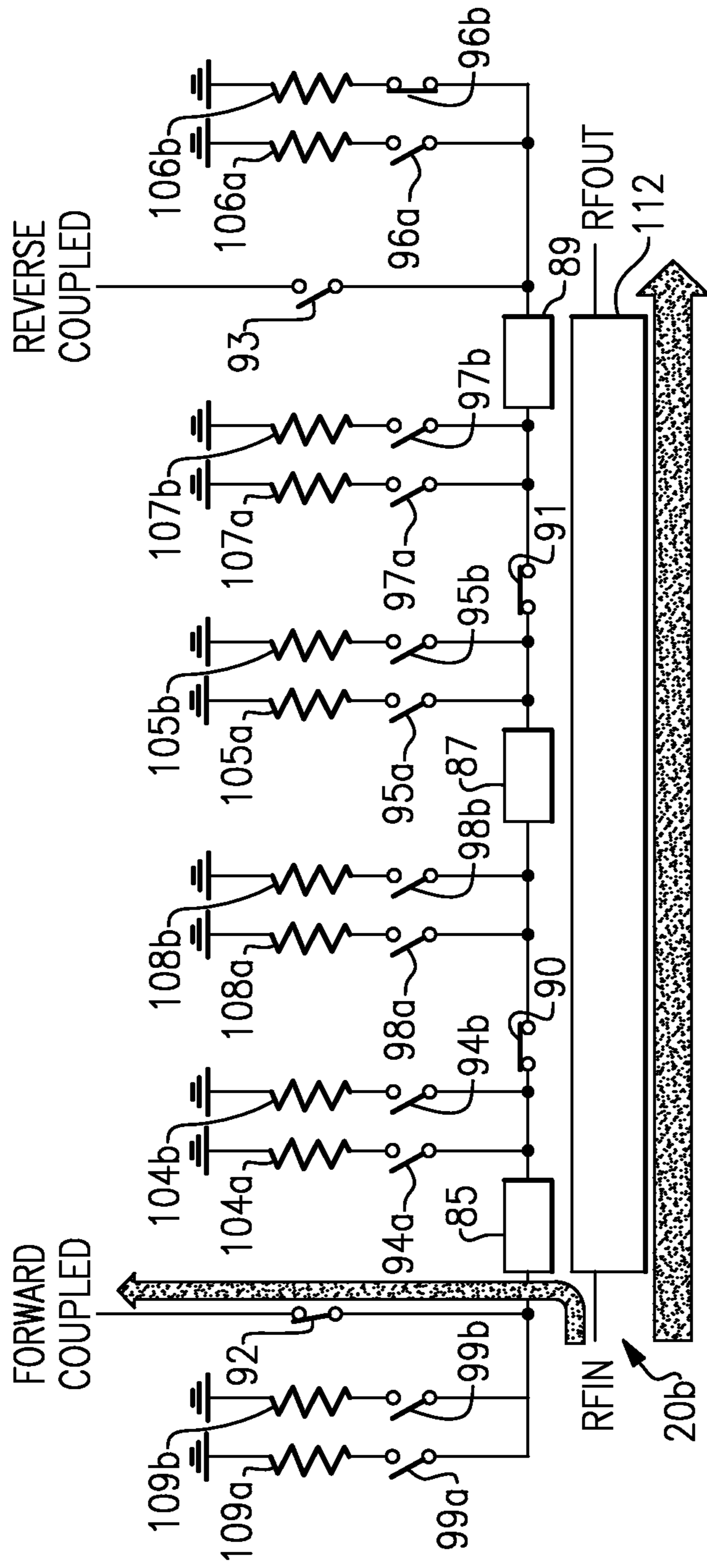
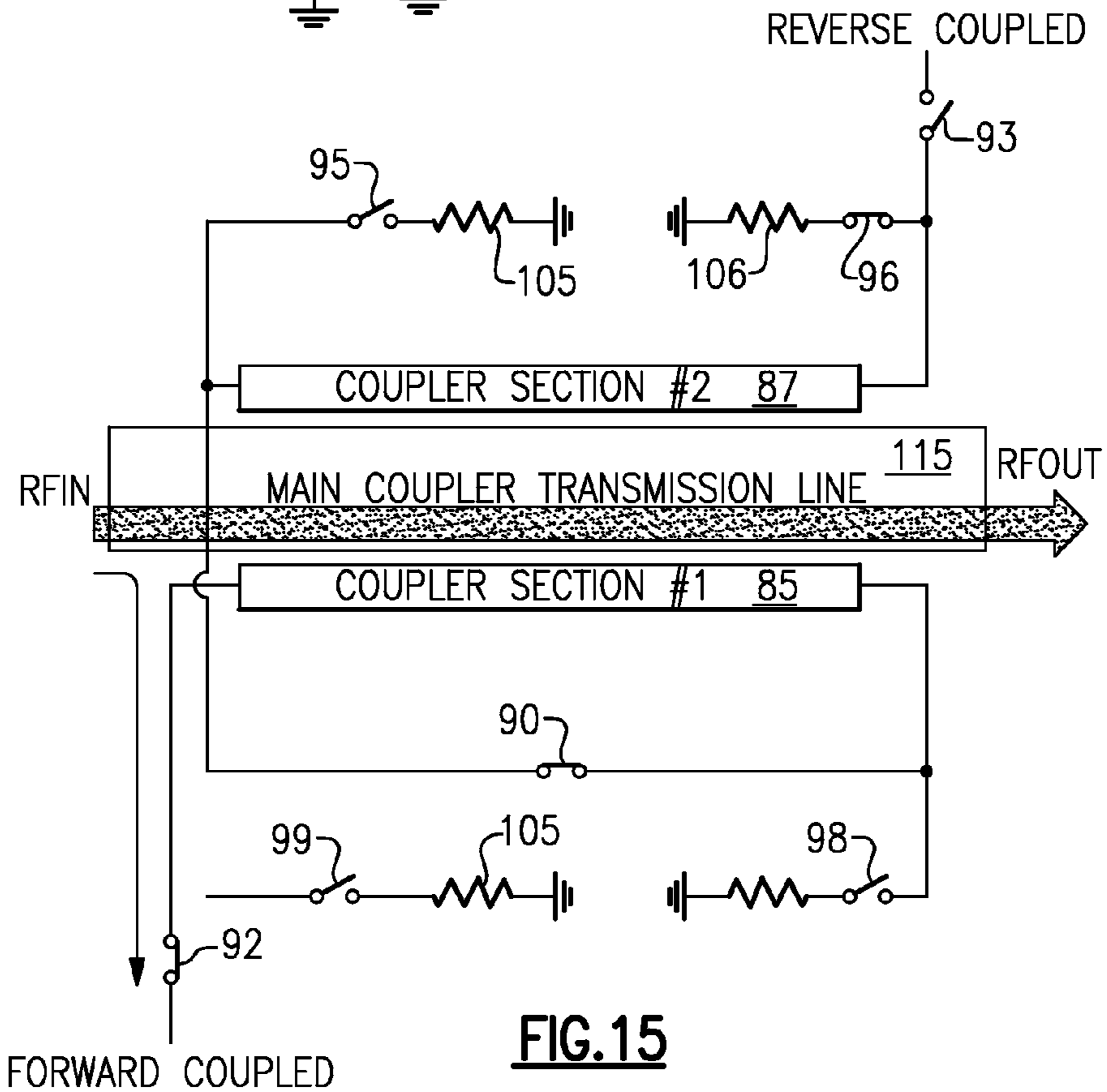
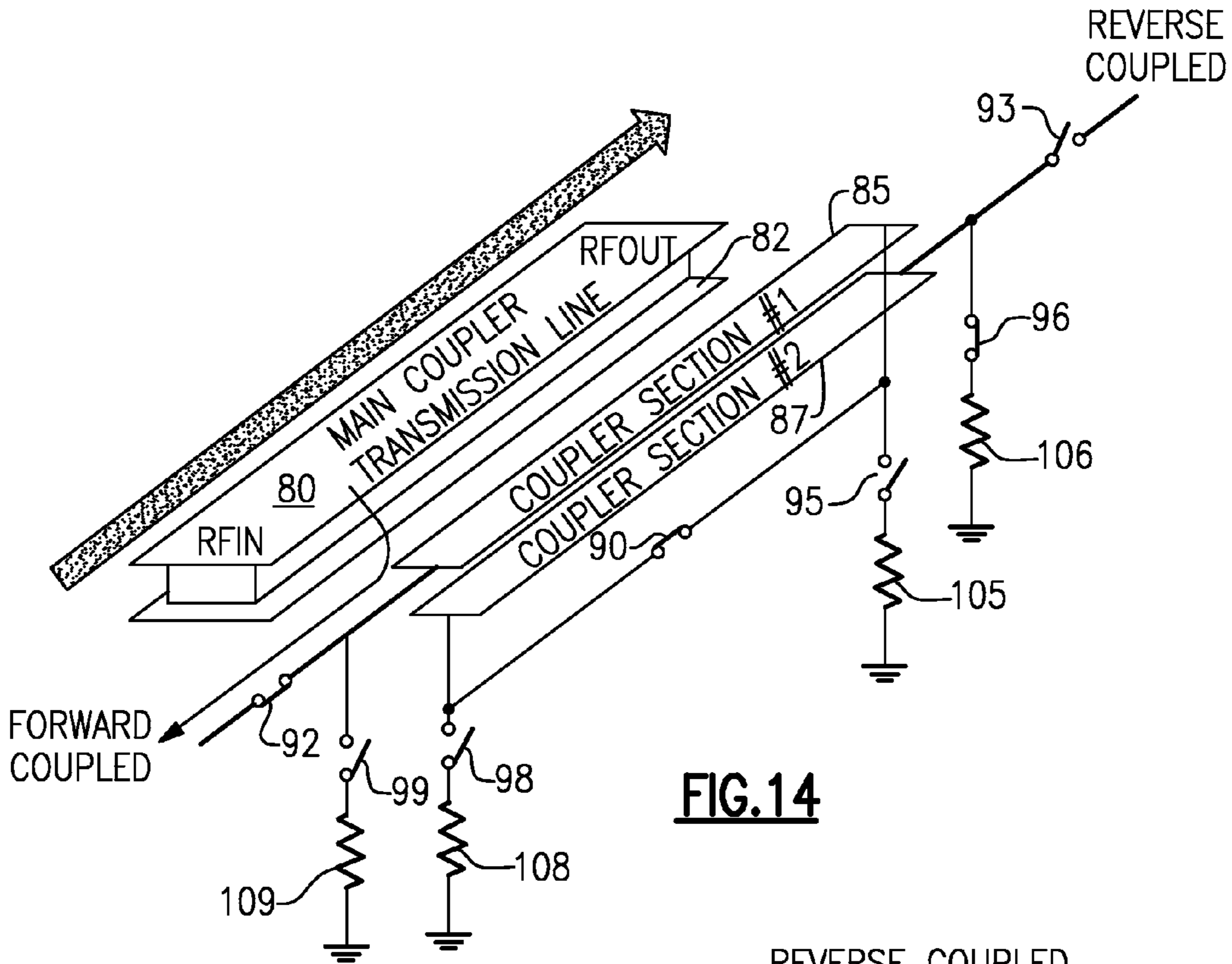

FIG. 13C



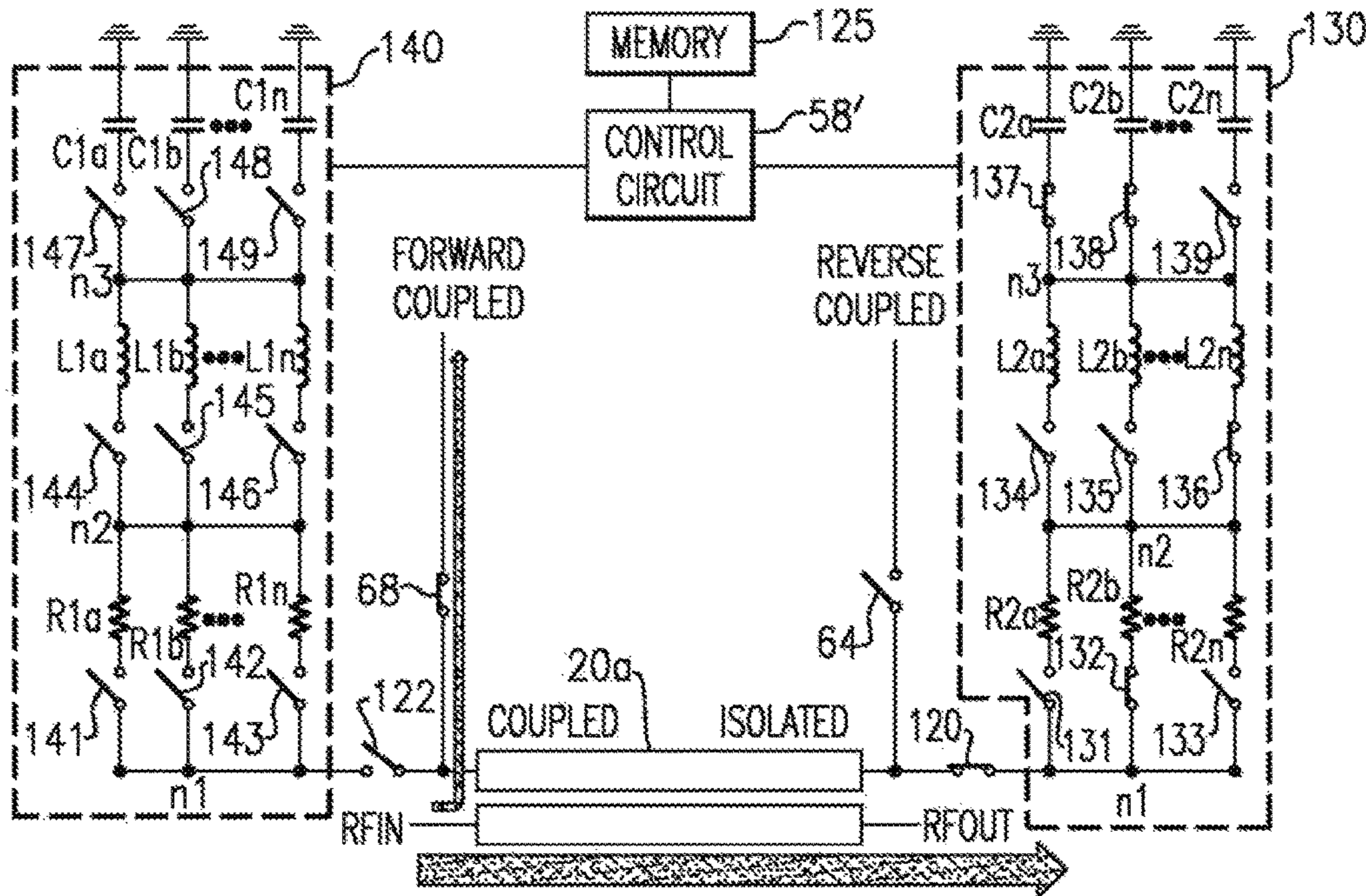

FIG. 16A

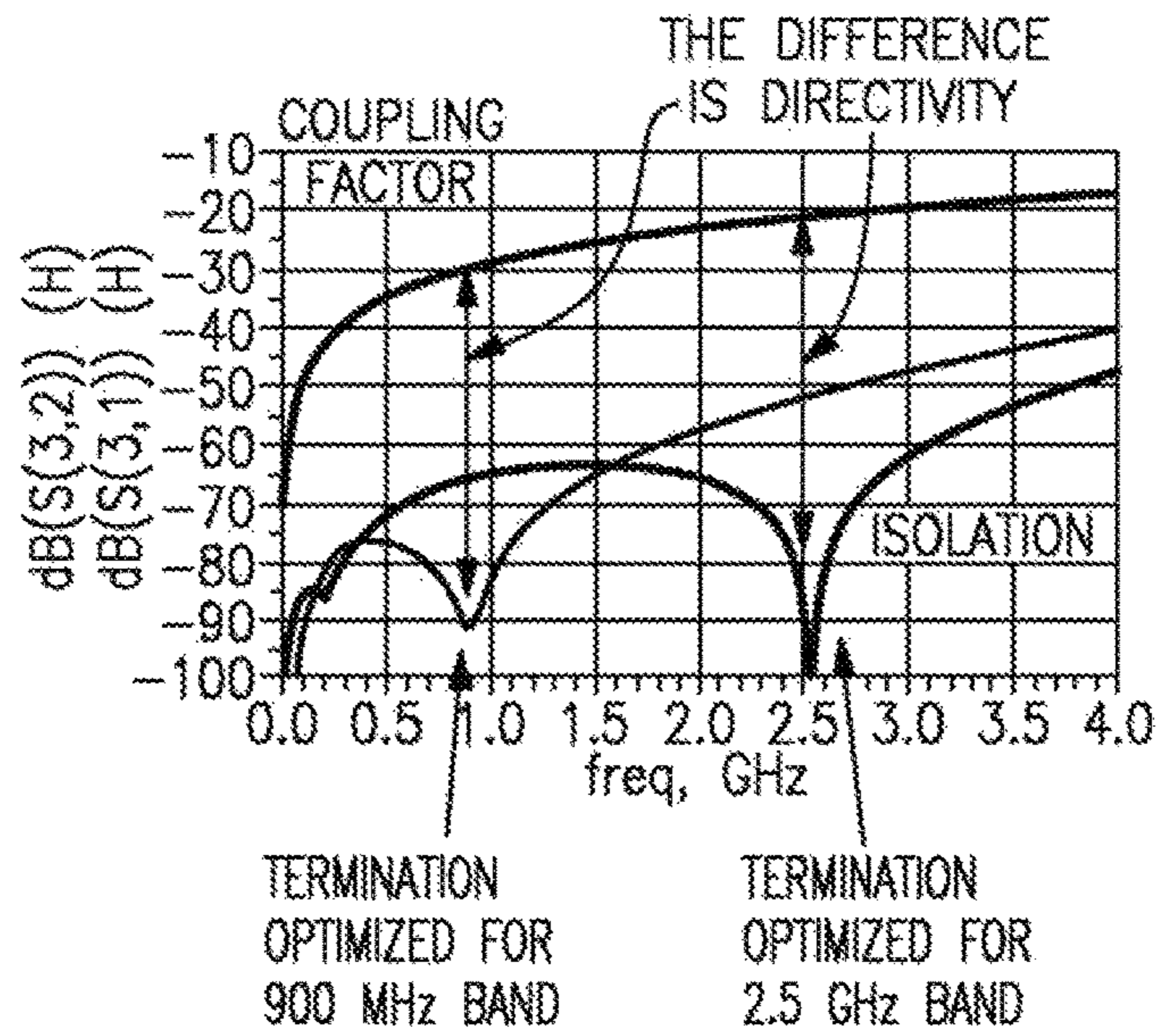

FIG. 16B

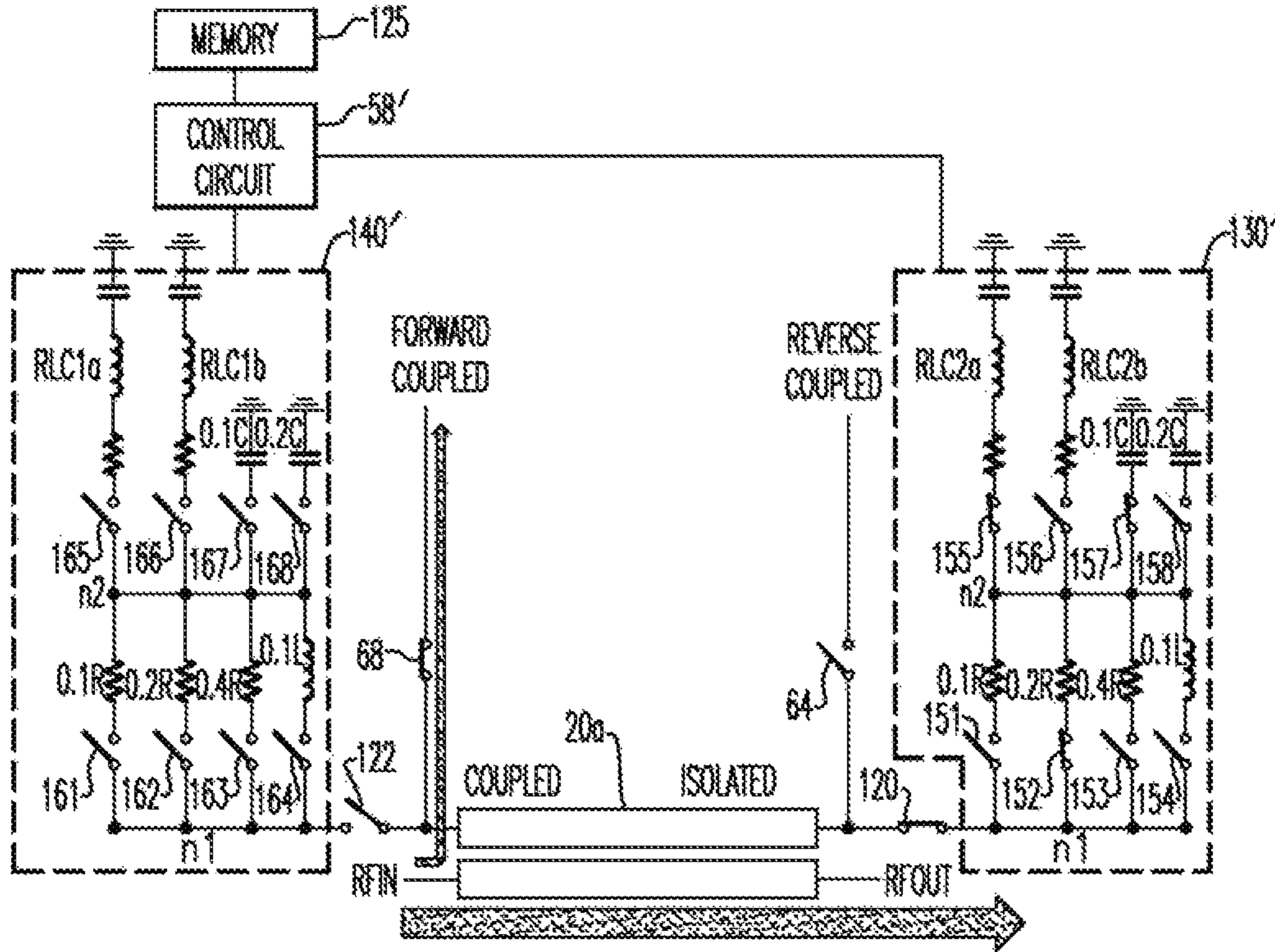

FIG.17A

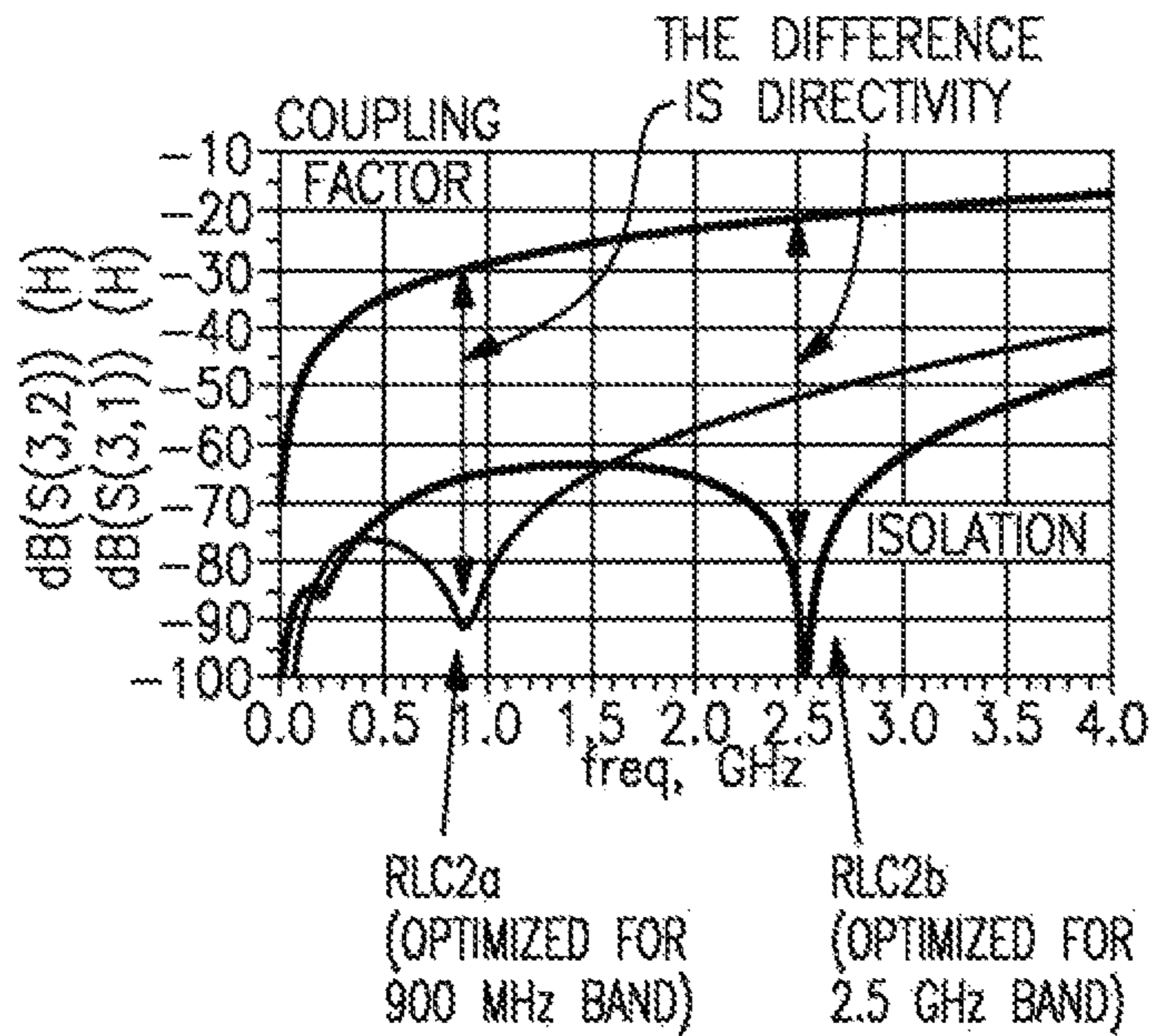
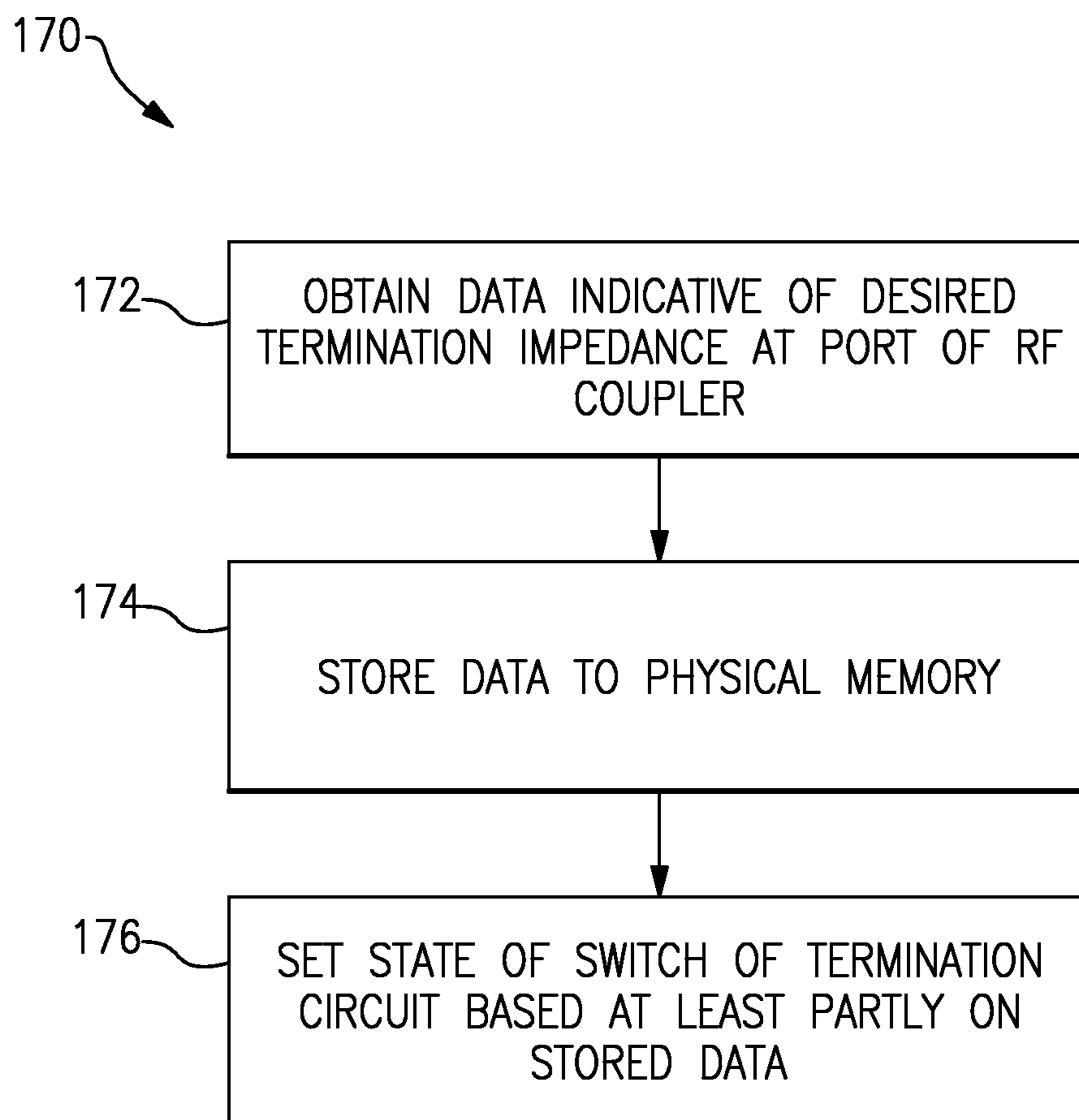

FIG.17B

**FIG.18**

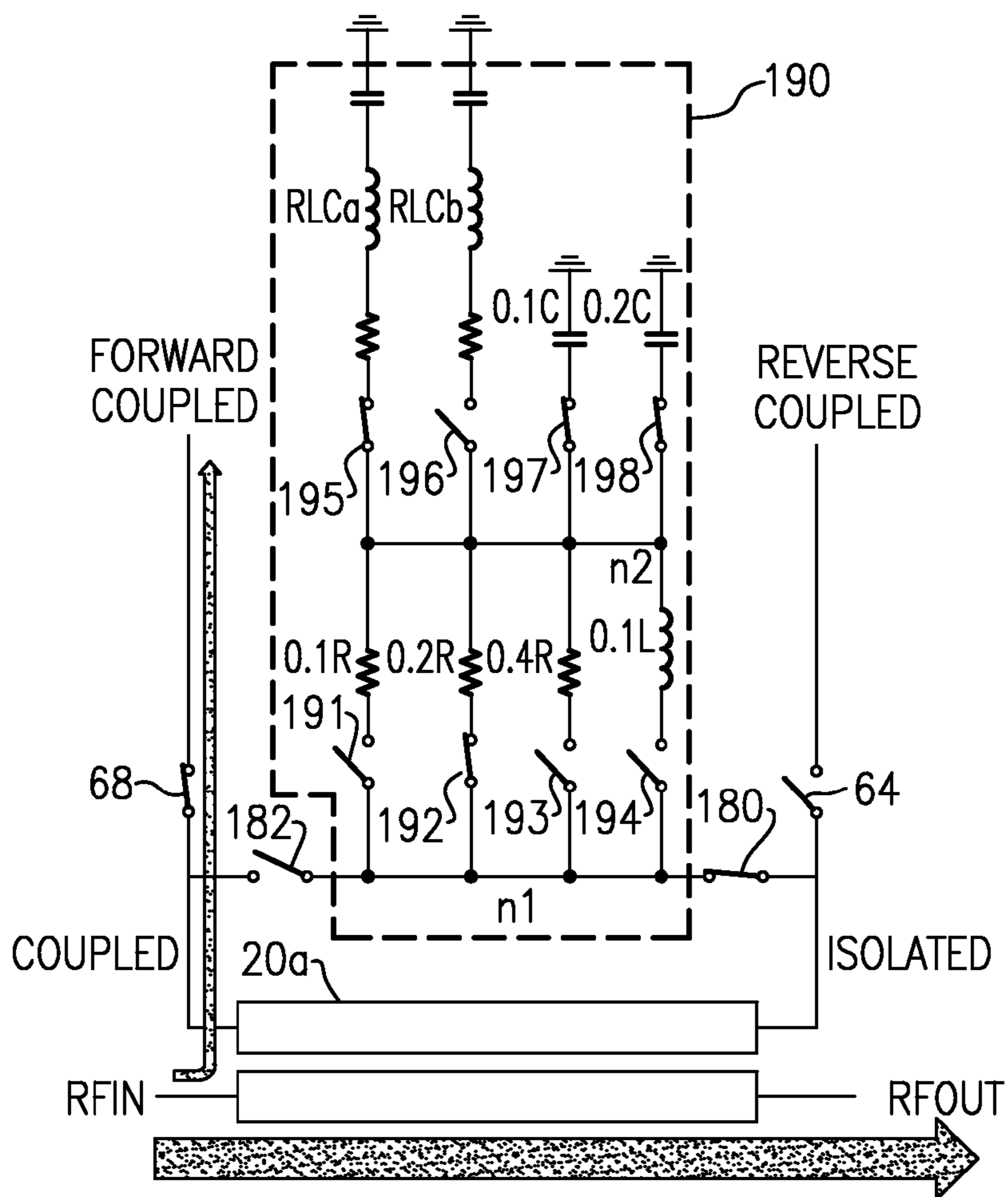

FIG. 19A

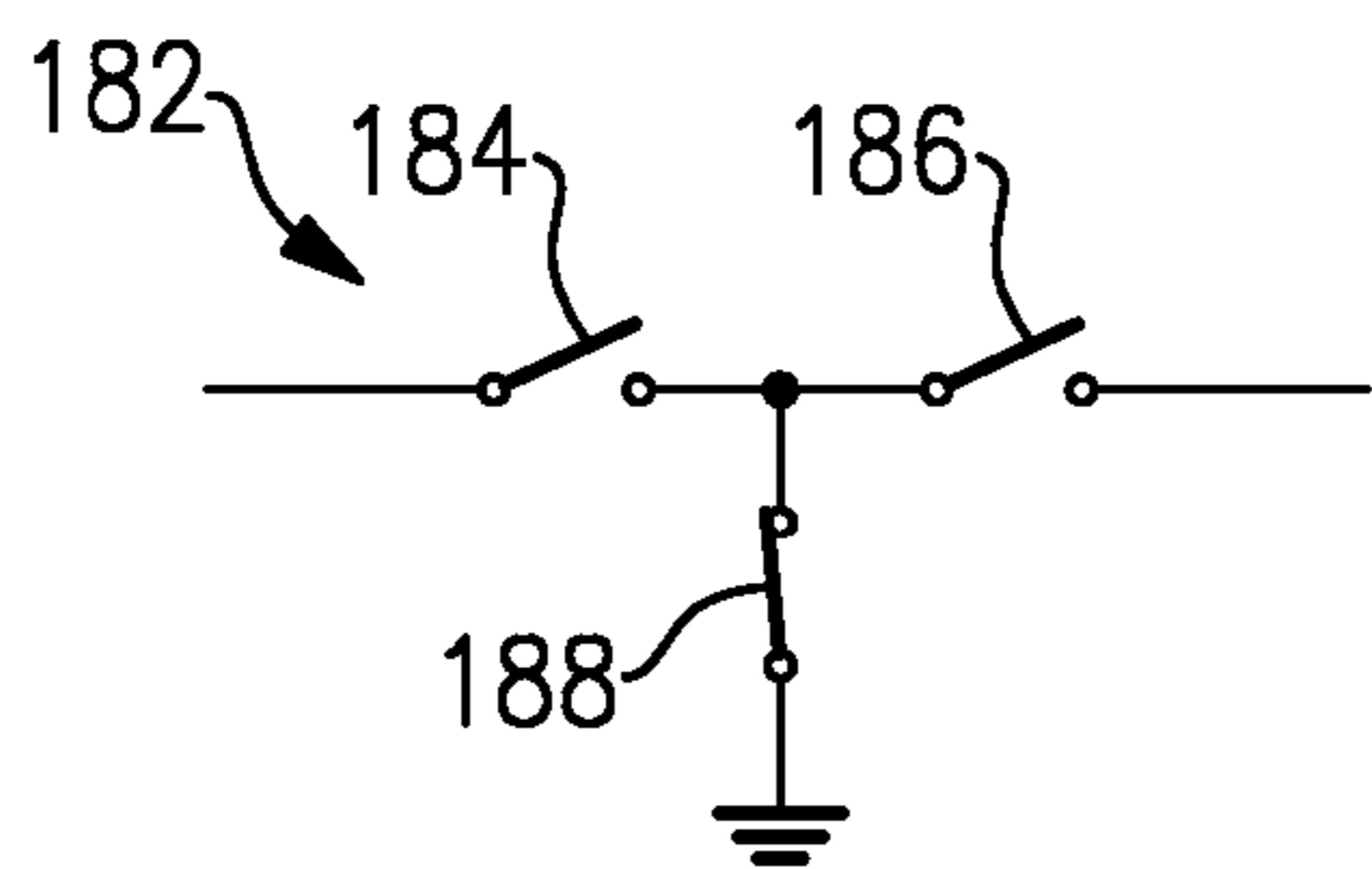

FIG. 19B

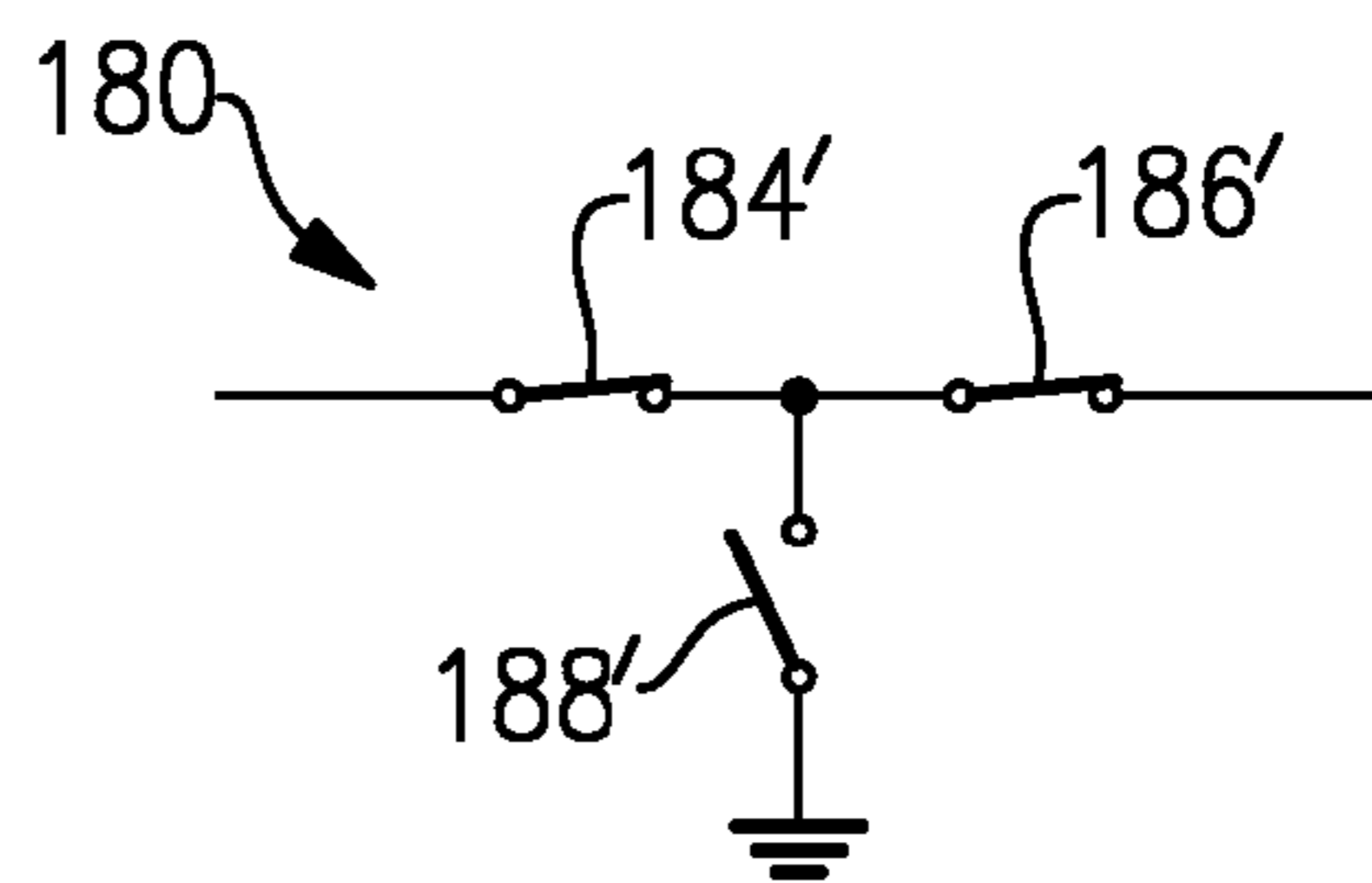

FIG. 19C

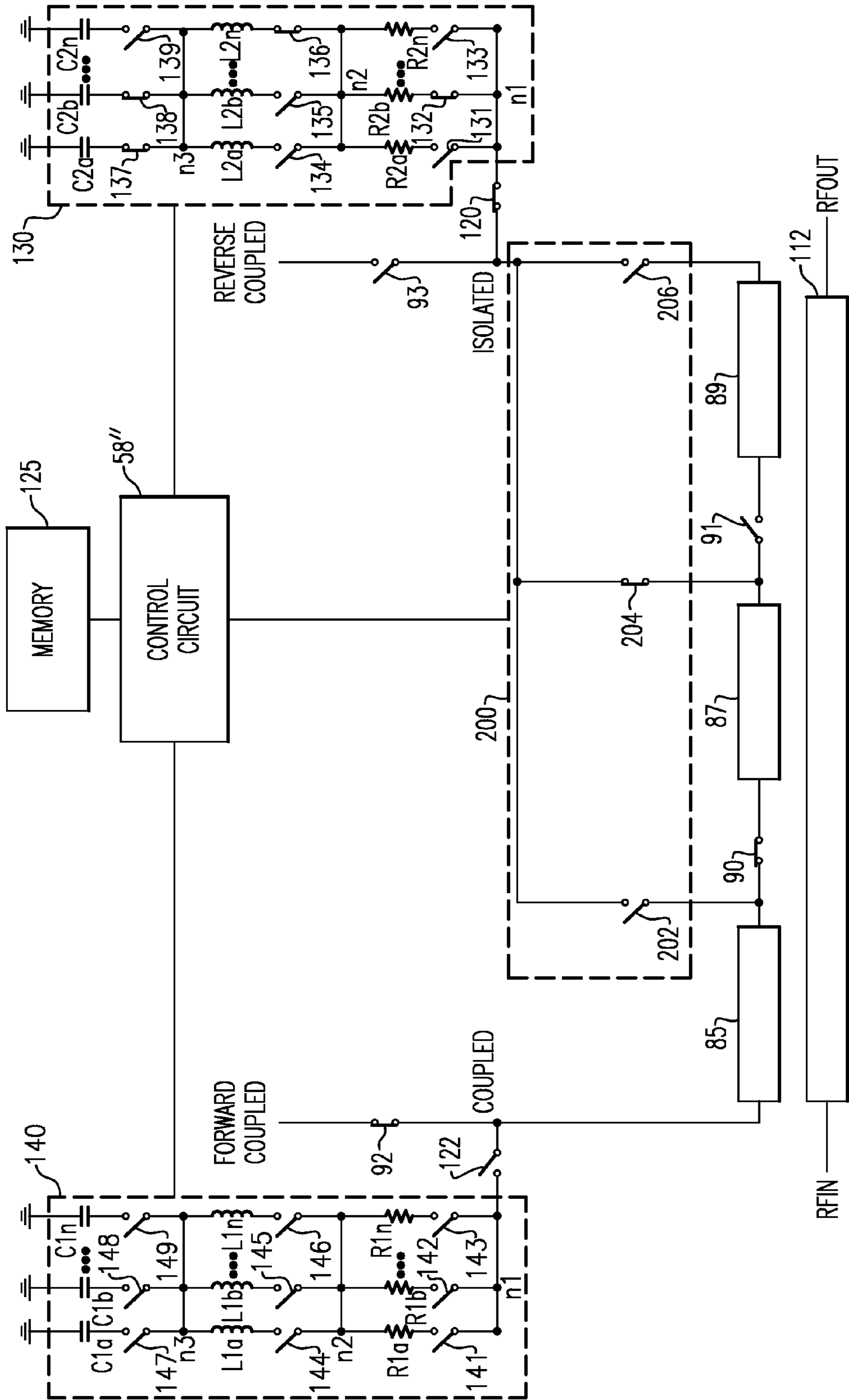

FIG.20

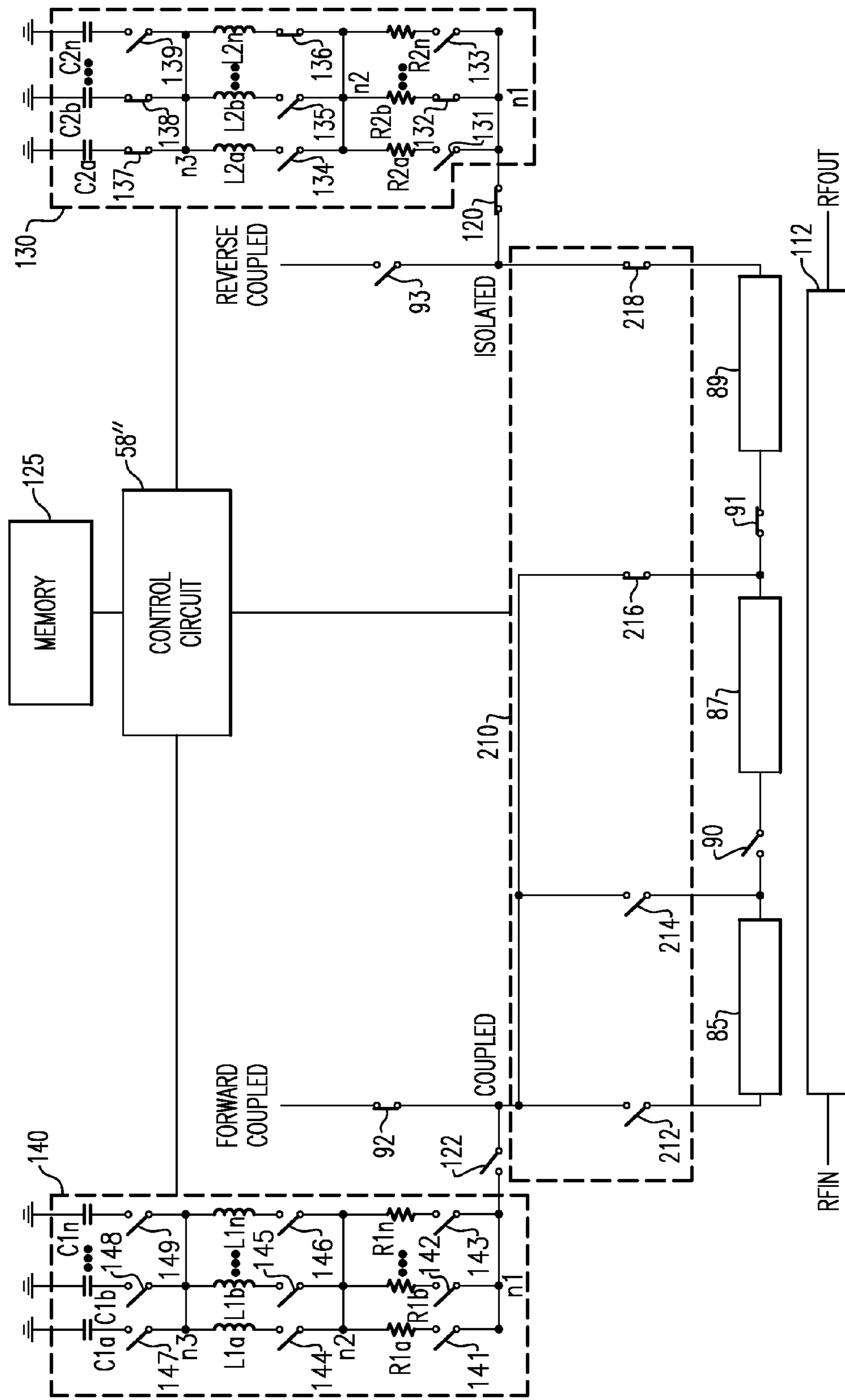
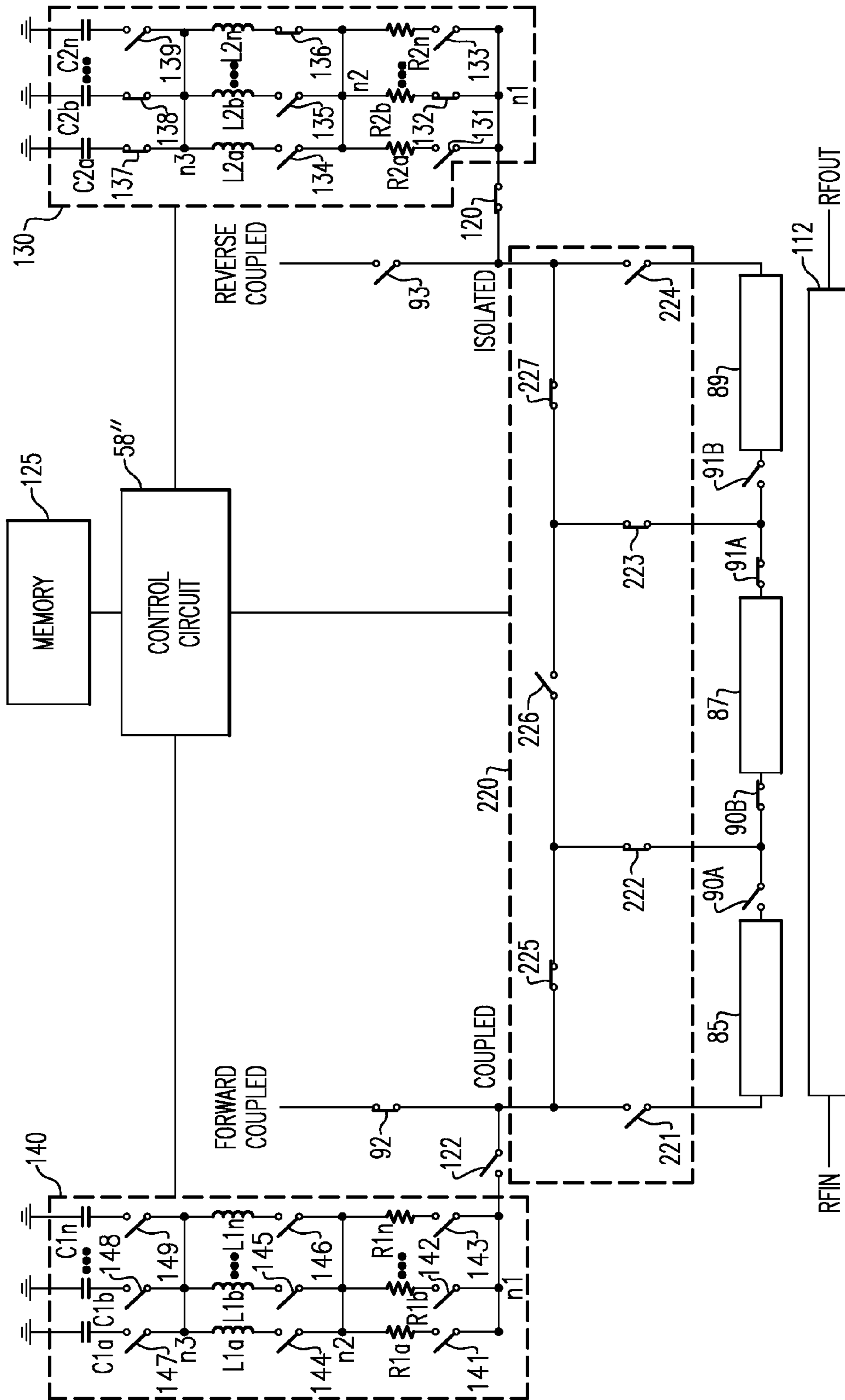

FIG.21



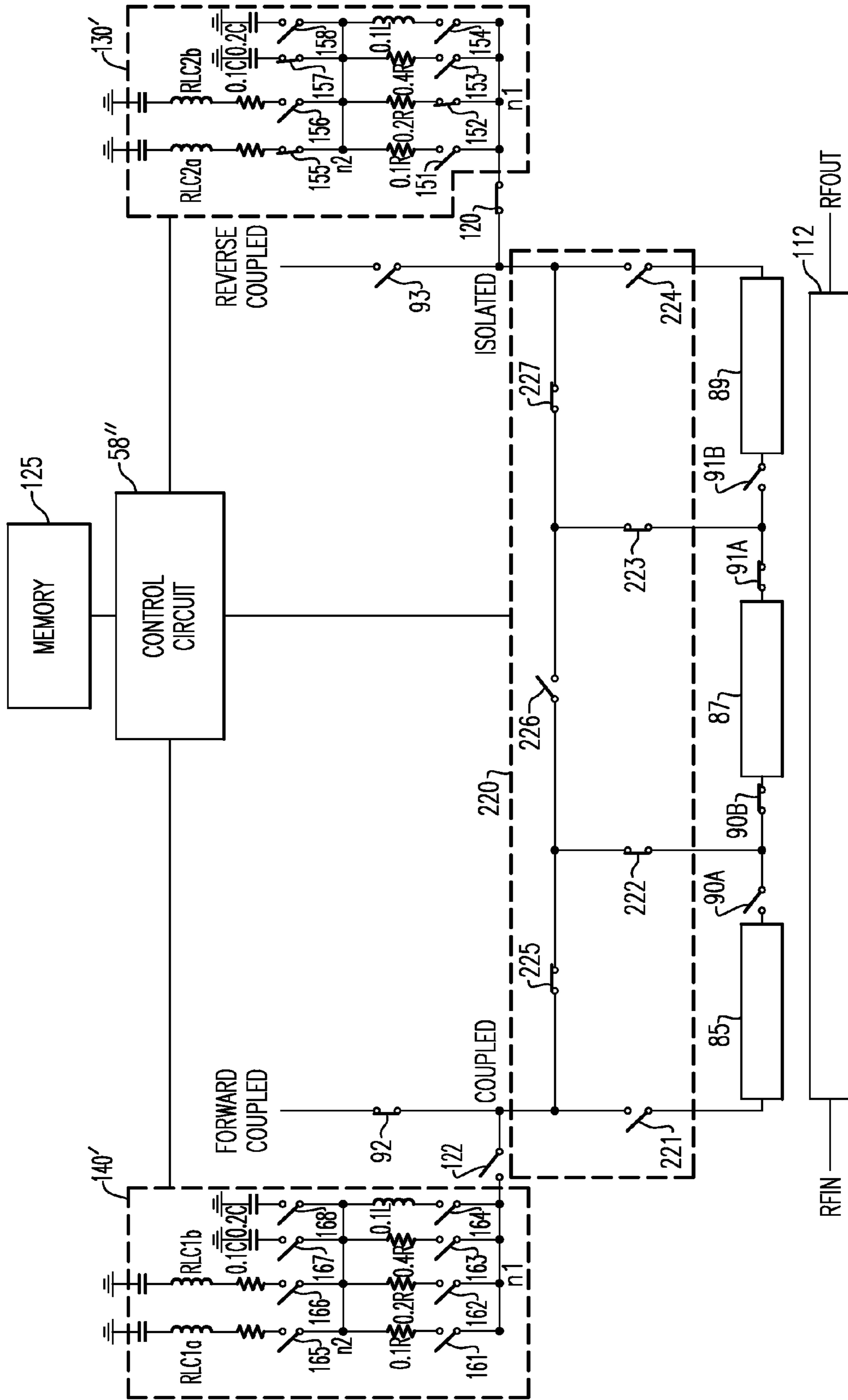

FIG. 22B

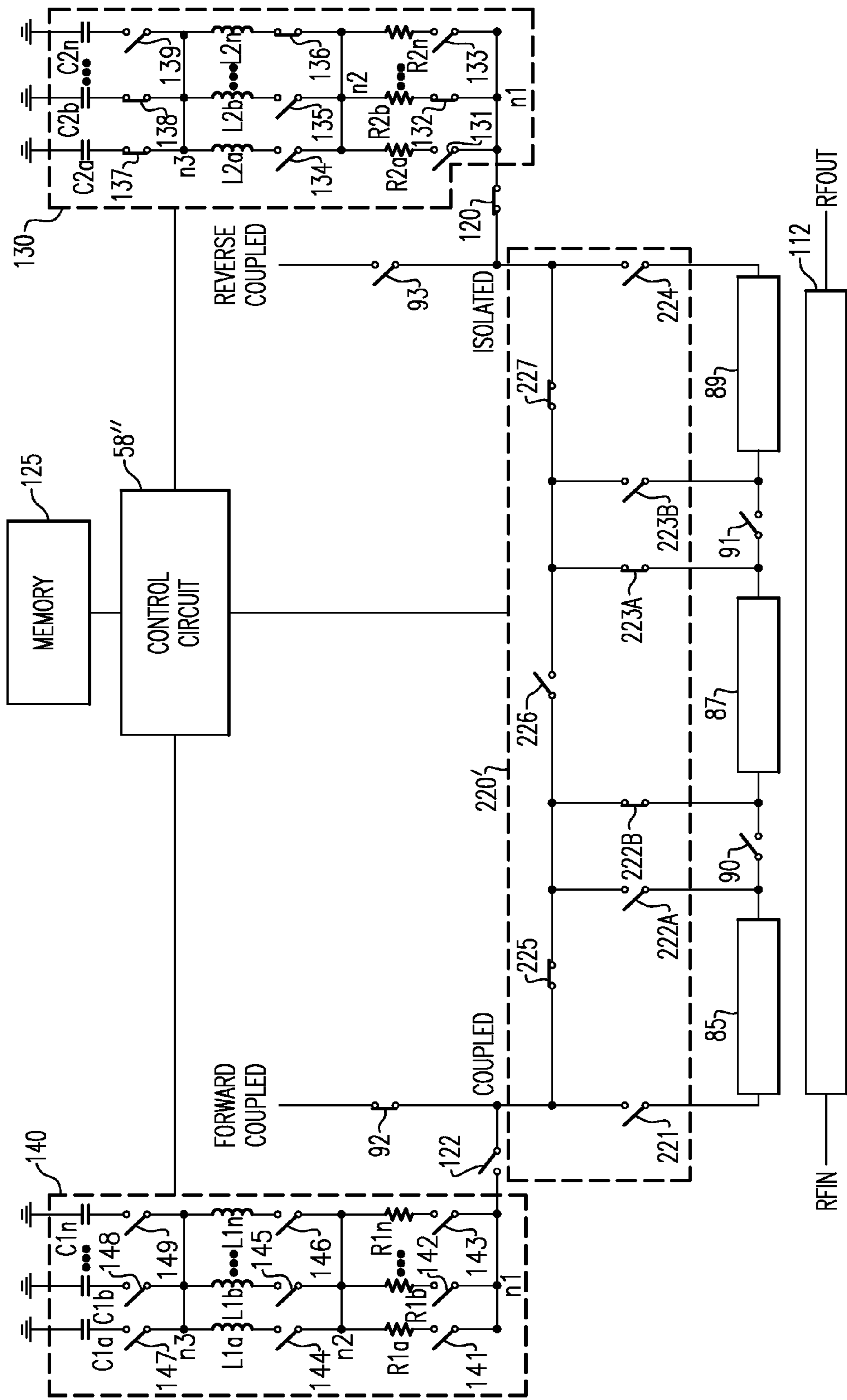

FIG. 22C

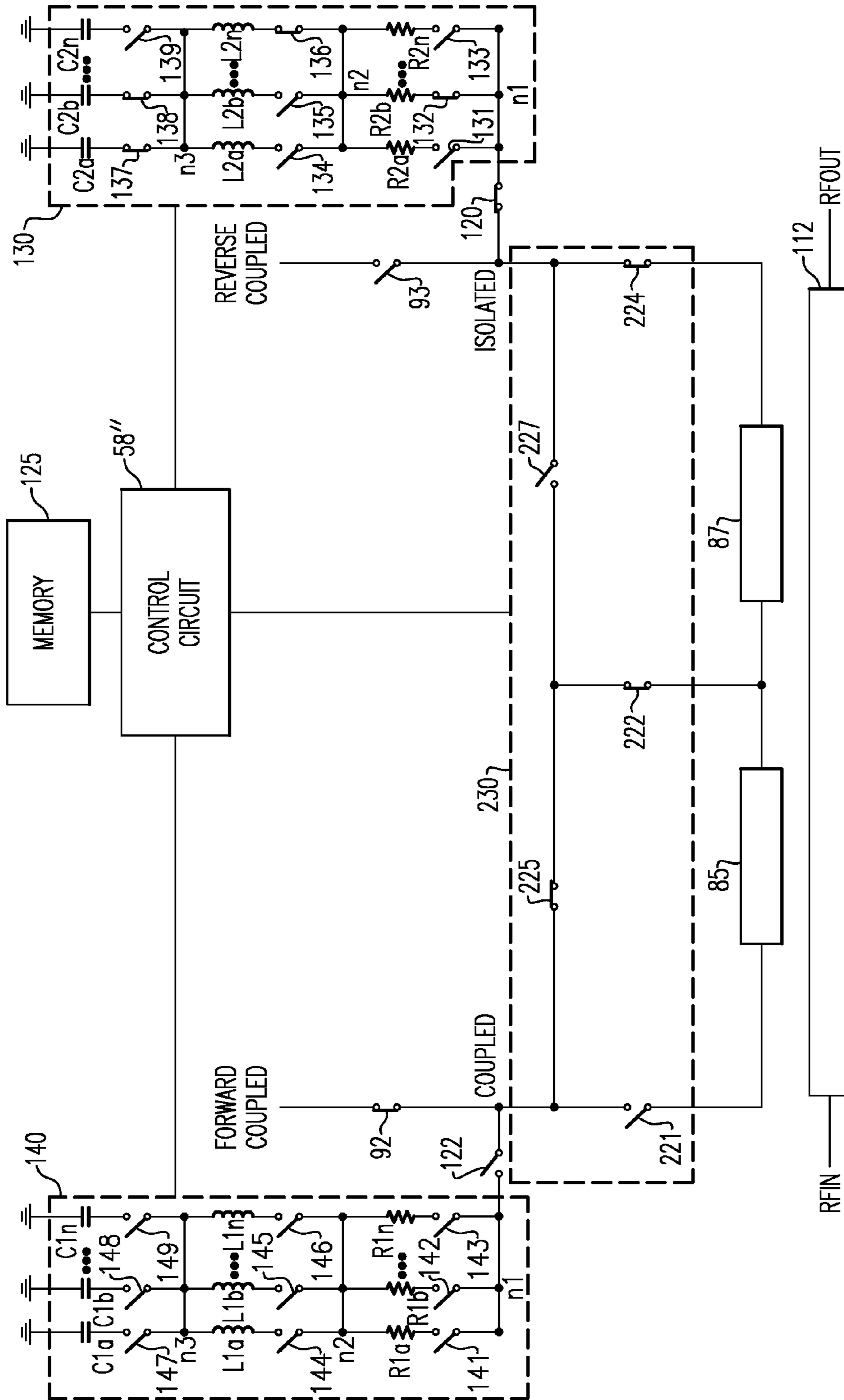

FIG. 23A

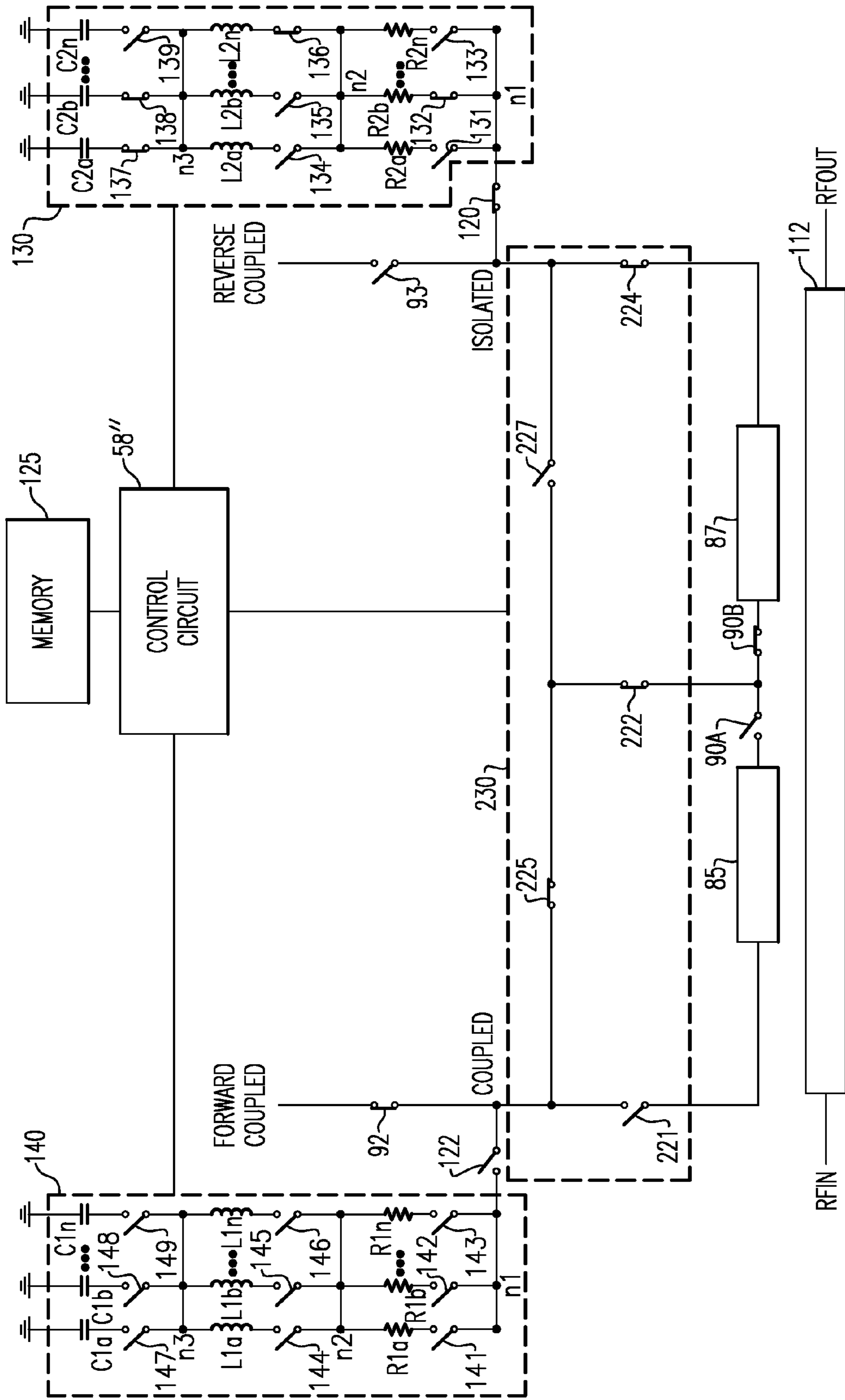

FIG. 23B

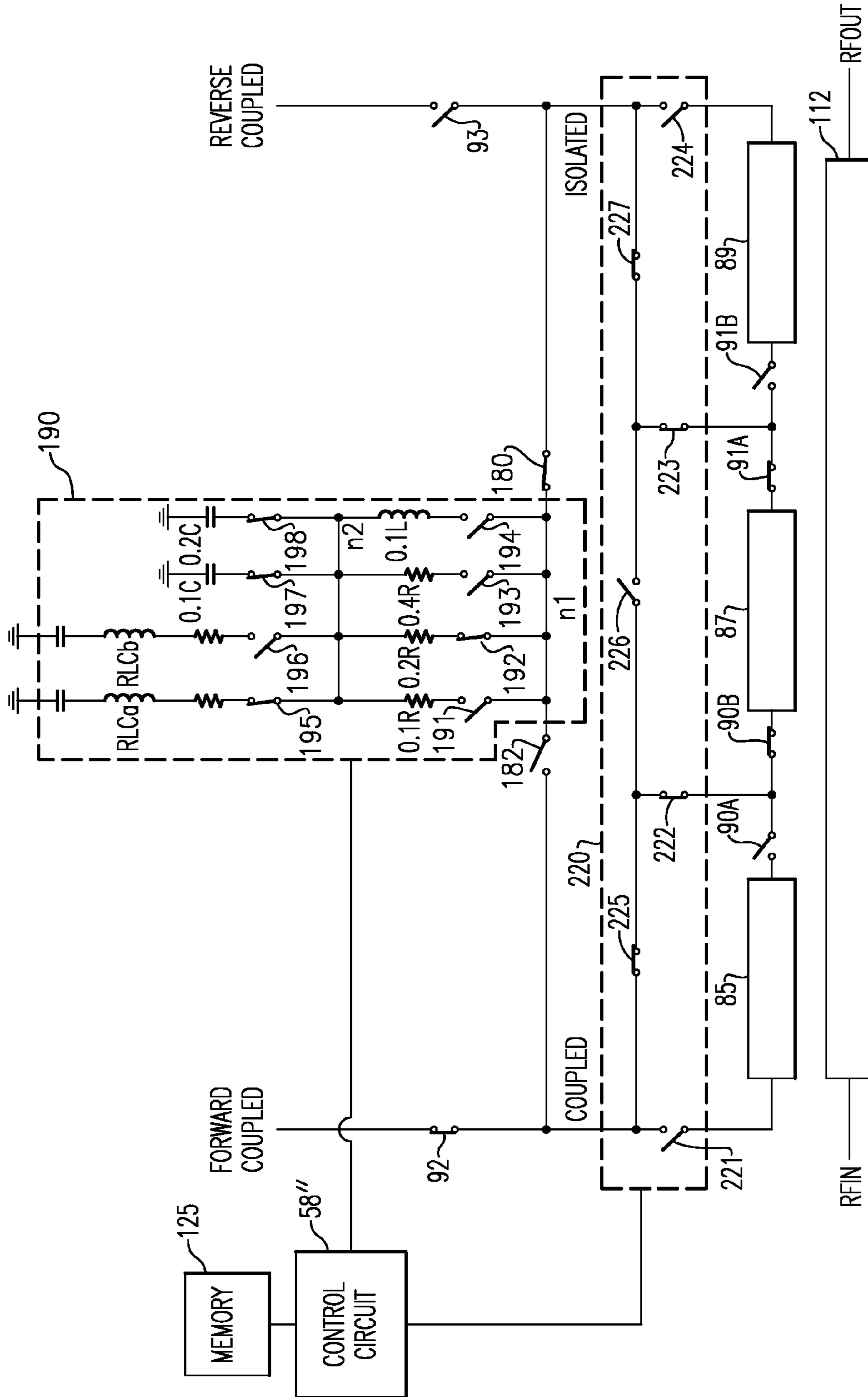

FIG. 24

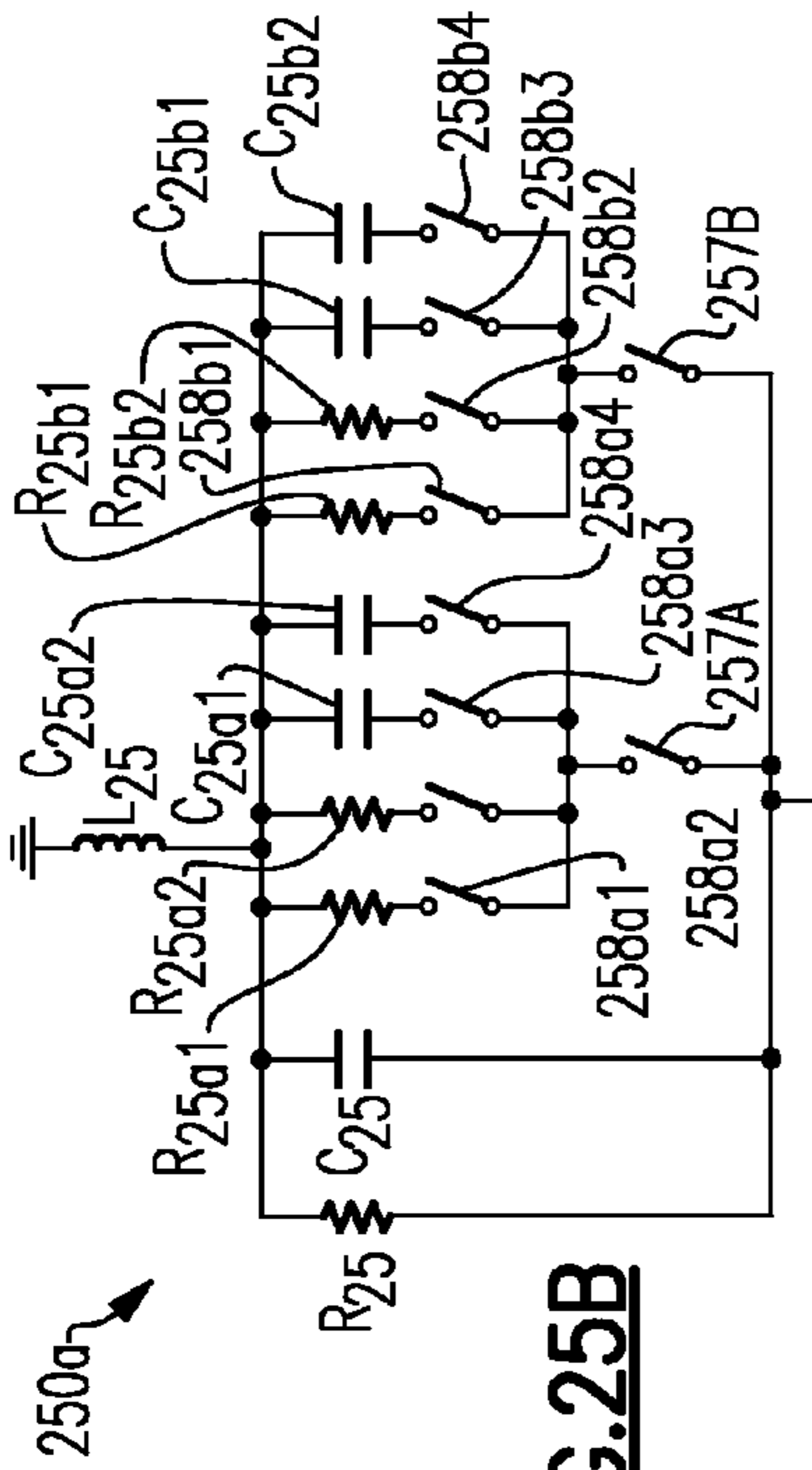

FIG. 25B

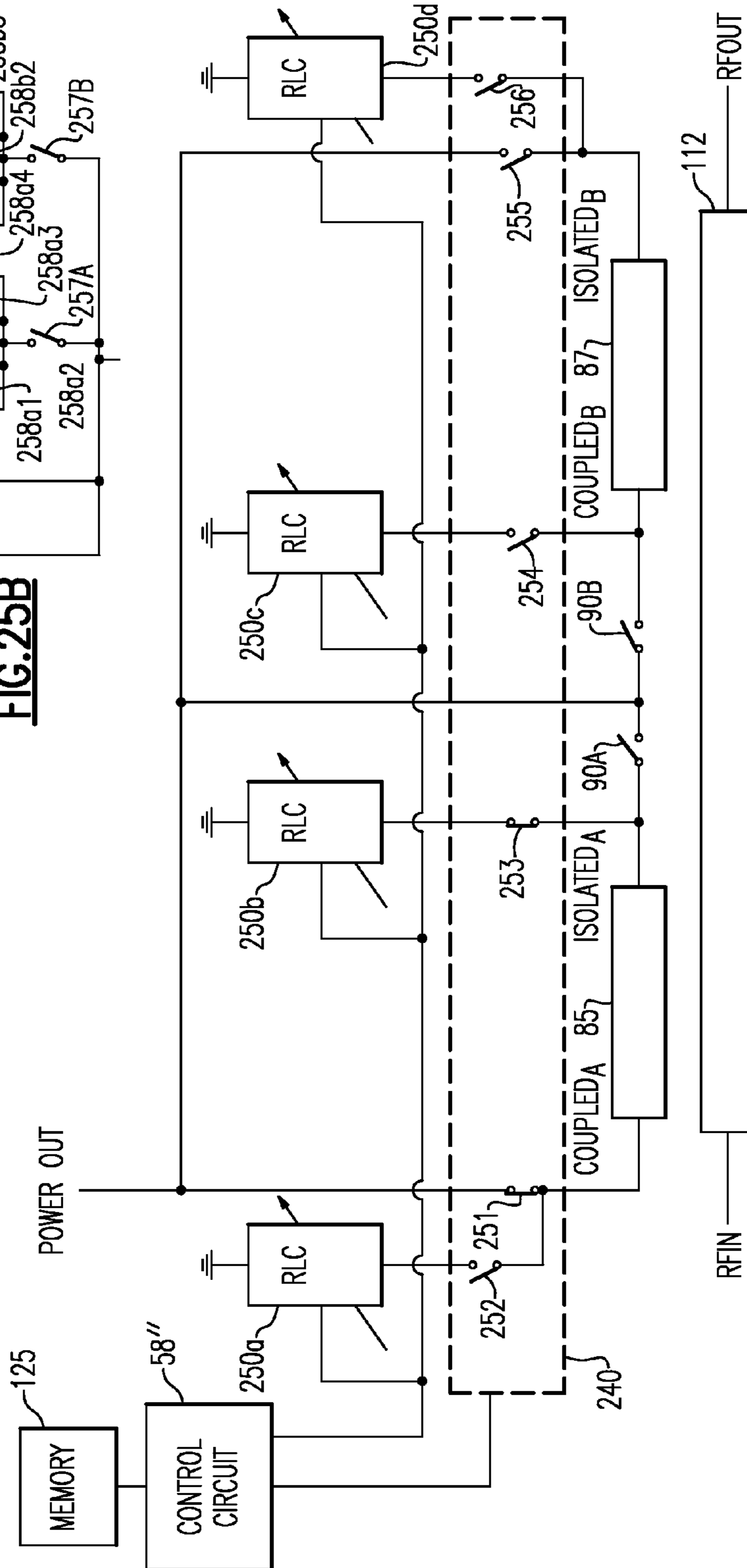
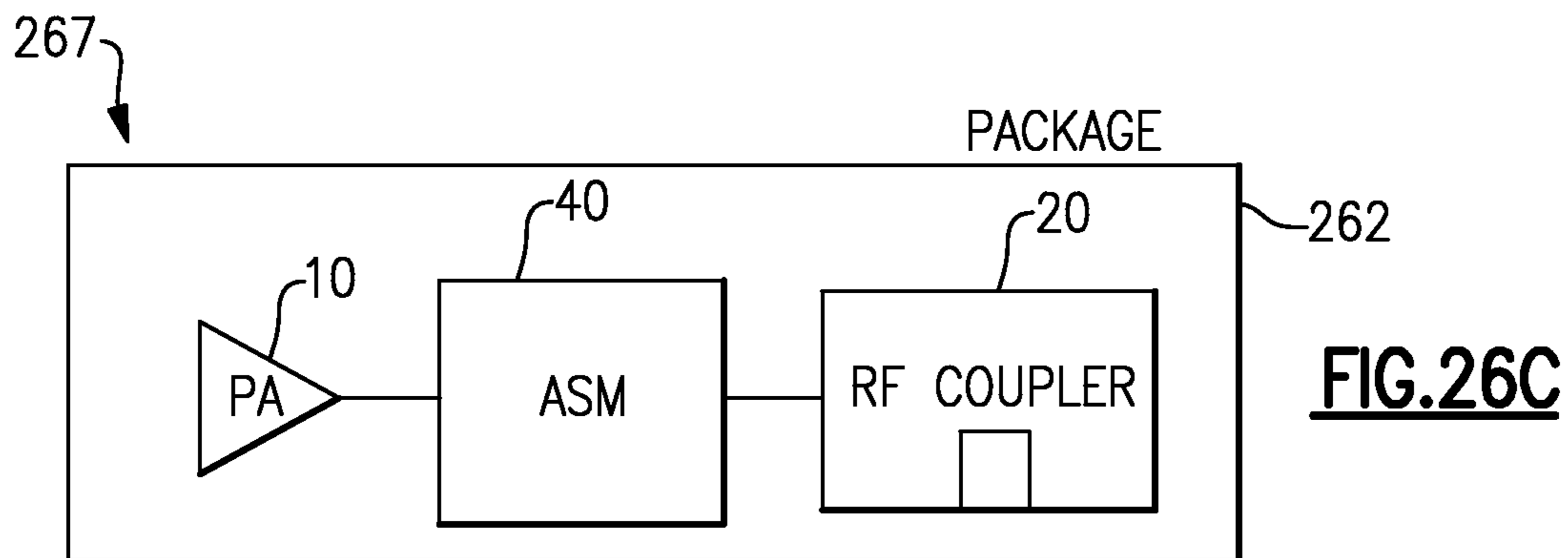
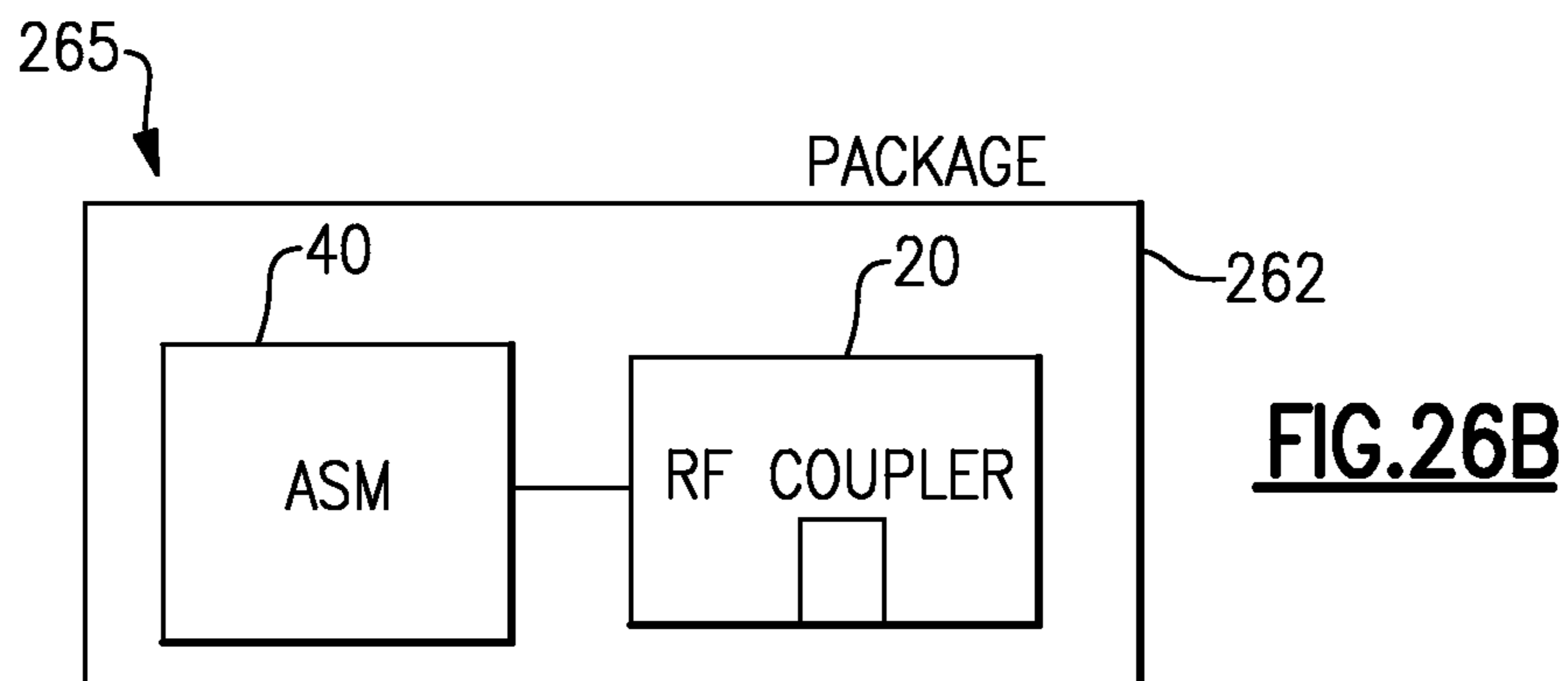
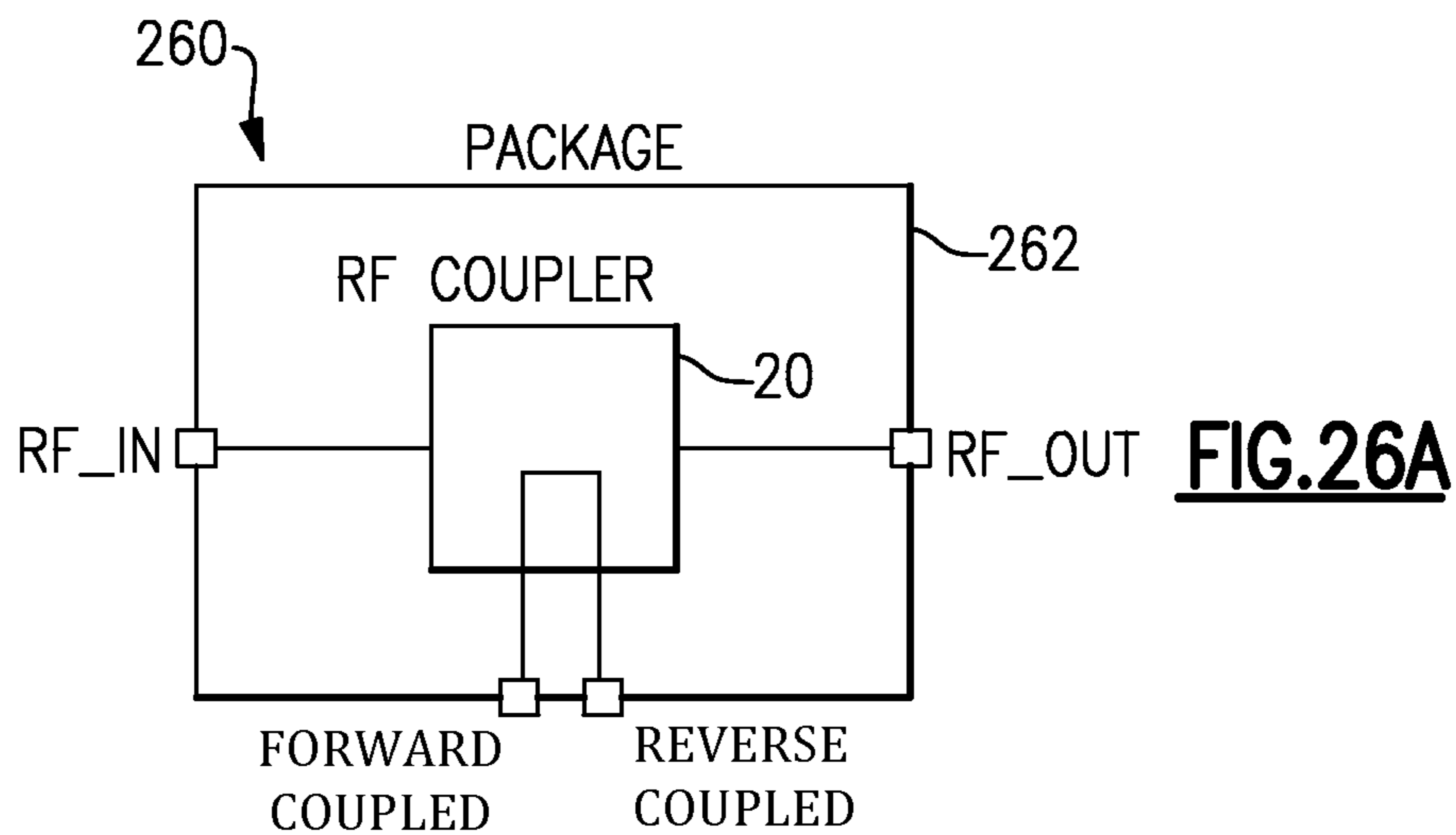

FIG. 25A



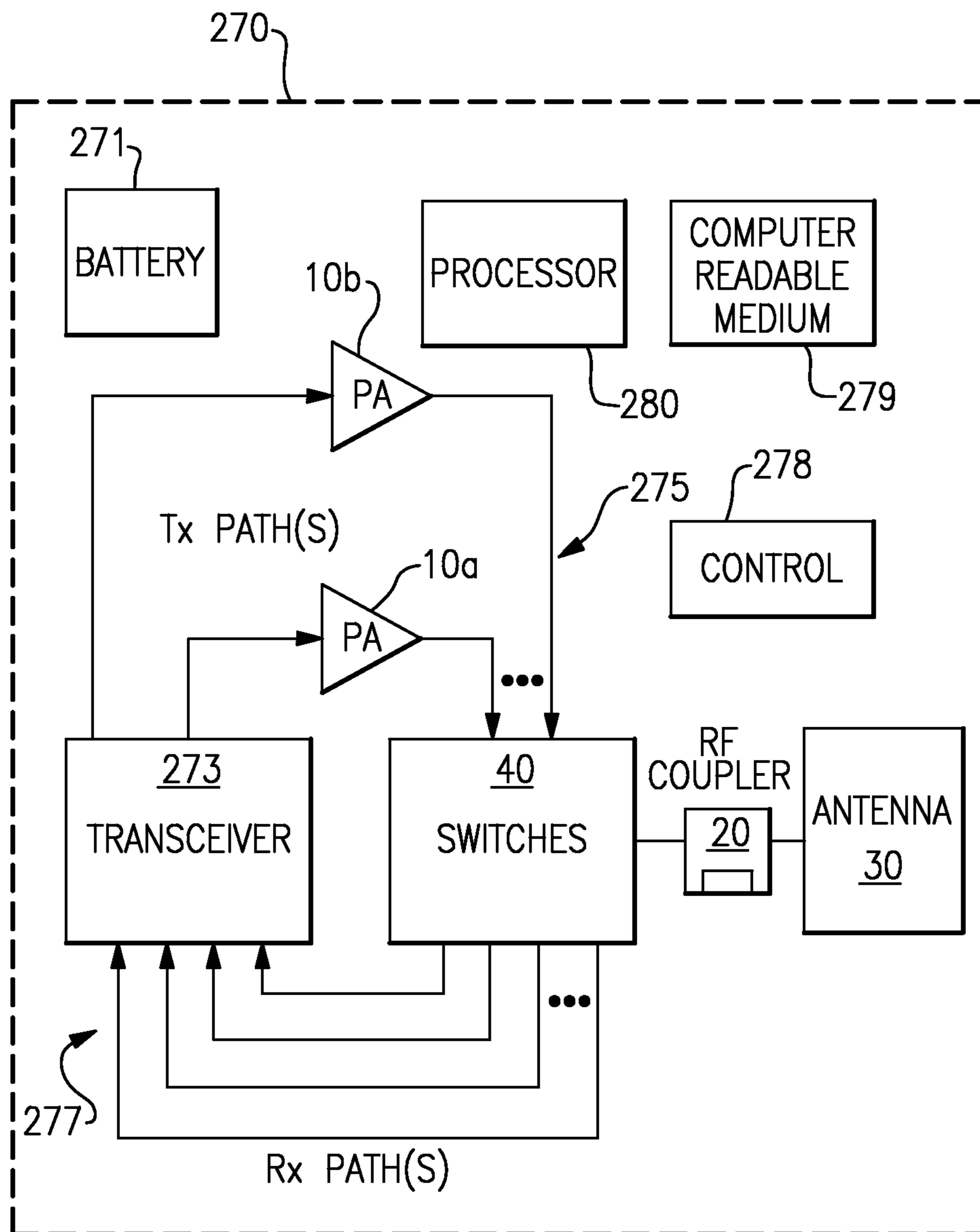

FIG.27

RF COUPLER HAVING COUPLED LINE WITH ADJUSTABLE LENGTH

CROSS-REFERENCE TO RELATED APPLICATIONS

This application claims the benefit of priority under 35 U.S.C. §119(e) of U.S. Provisional Patent Application No. 62/090,015, filed Dec. 10, 2014 and titled "RADIO FREQUENCY COUPLER", the entire disclosure of which is hereby incorporated by reference in its entirety herein. This application also claims the benefit of priority under 35 U.S.C. §119(e) of U.S. Provisional Patent Application No. 62/110,248, filed Jan. 30, 2015 and titled "RADIO FREQUENCY COUPLERS", the entire disclosure of which is hereby incorporated by reference in its entirety herein.

The present disclosure relates to U.S. patent application Ser. No. 14/745,145, titled "RF COUPLER WITH DECOUPLED STATE," U.S. patent application Ser. No. 14/745,210, titled "RF COUPLER WITH SWITCH BETWEEN COUPLER PORT AND ADJUSTABLE TERMINATION IMPEDANCE CIRCUIT," and U.S. patent application Ser. No. 14/745,154, titled "RF COUPLER WITH ADJUSTABLE TERMINATION IMPEDANCE," each filed on Jun. 19, 2015, and the disclosure of each of which is hereby incorporated by reference herein in its entirety.

BACKGROUND

Technical Field

This disclosure relates to electronic systems and, in particular, to radio frequency (RF) couplers.

Description of the Related Technology

Radio frequency (RF) sources, such as RF amplifiers, can provide RF signals. When an RF signal generated by an RF source is provided to a load, such as to an antenna, a portion of the RF signal can be reflected back from the load. An RF coupler can be included in a signal path between the RF source and the load to provide an indication of forward RF power of the RF signal traveling from the RF amplifier to the load and/or an indication of reverse RF power reflected back from the load. RF couplers include, for example, direction couplers, bi-directional couplers, multi-band couplers (e.g., dual-band couplers), etc.

An RF coupler can have a coupled port, an isolated port, a power input port, and a power output port. When a termination impedance is presented to the isolated port, an indication of forward RF power traveling from the power input port to the power output port can be provided at the coupled port. When a termination impedance is presented to the coupled port, an indication of reverse RF power traveling from the power output port to the power input port can be provided at the isolated port. The termination impedance has been implemented by a 50 Ohm shunt resistor in a variety of conventional RF couplers.

An RF coupler has a coupling factor, which can represent how much power is provided to the coupled port of the RF coupler relative to the power of an RF signal at the power input port. RF couplers typically cause an insertion loss in an RF signal path. Thus, an RF signal received at the power input port of an RF coupler can have a lower power when provided at the power output port of the RF coupler. Insertion loss can be due to a portion of the RF signal being

provided to the coupled port (or to the isolated port) and/or to losses associated with the main transmission line of the RF coupler.

SUMMARY OF CERTAIN INVENTIVE ASPECTS

The innovations described in the claims each have several aspects, no single one of which is solely responsible for its desirable attributes. Without limiting the scope of the claims, some prominent features of this disclosure will now be briefly described.

One aspect of this disclosure is an apparatus that includes a radio frequency coupler. The radio frequency coupler includes a power input port, a power output port, a coupled port, a multi-section coupled line, and a switch configured to adjust an effective length of the multi-section coupled line.

The effective length of the multi-section coupled line can be a length of the coupled line electrically connected between the coupled port and a termination impedance. The multi-section coupled line can include at least a first section and a second section, and the switch is disposed in series between the first section and the second section. The radio frequency coupler can further include a second switch, the multi-section coupled line can include a third section, and the second switch can be configured to selectively electrically connect the third section to the coupled port.

The apparatus can further include a first termination impedance element electrically coupleable to a first section of the multi-section coupled line and a second termination impedance element electrically coupleable to a second section of the multi-section coupled line.

The apparatus can further include an adjustable termination impedance circuit electrically connectable to a section of the multi-section coupled line, in which the adjustable termination impedance circuit is configured to provide a termination impedance to the section of the multi-section coupled line.

The apparatus can further include an adjustable termination impedance circuit and a switch network, in which the switch network is configured to selectively electrically couple the adjustable termination impedance circuit to a first section of the multi-section coupled line and to selectively electrically couple the adjustable termination impedance circuit to a second section of the multi-section coupled line.

The radio frequency coupler can include a main line implemented by a continuous conductive structure electrically connecting the power input port and the power output port. The radio frequency coupler can be configured to operate in a decoupled state in which each section of the multi-section coupled line is decoupled from a main line electrically connecting the power input port and the power output port.

The apparatus can further include a switch network arranged to configure the radio frequency coupler into a first state to provide an indication of forward power and into a second state to provide an indication of reflected power.

The apparatus can include a control circuit configured to adjust the state of the switch. The apparatus can further include a switch network configured to electrically couple a first impedance element to a first end of a first section of the multi-section coupled line and electrically couple a second end of the first section of the multi-section coupled line to a power output in a first state, and to electrically couple a second impedance element to a first end of a second section of the multi-section coupled line and electrically couple a

second end of the second section of the multi-section coupled line to the power output in a second state.

The apparatus can further include a package enclosing the radio frequency coupler. The apparatus can further include an antenna switch module in communication with the radio frequency coupler, in which the antenna switch module enclosed within the package. The apparatus can further include a power amplifier configured to provide a radio frequency signal to the radio frequency coupler by way of the antenna switch module, in which the power amplifier is enclosed within the package.

Another aspect of this disclosure is an apparatus that includes a radio frequency coupler that includes a power input port, a power output port, a port configured to provide an indication of power of a radio frequency signal traveling between the power input port and the power output port, and a coupled line. The coupled line includes at least a first section and a second section. The radio frequency coupler further includes a switch electrically connected to a node in a path between the first section of the coupled line and the second section of the coupled line. The switch is configured to adjust a length of the coupled line electrically connected between the port configured to provide the indication of power and a termination impedance.

The port configured to provide the indication of power of a radio frequency signal traveling between the power input port and the power output port can be a coupled port that provides an indication of power traveling from the power input port to the power output port. The port configured to provide the indication of power of a radio frequency signal traveling between the power input port and the power output port can be an isolated port that provides an indication of power traveling from the power output port to the power input port. The switch can be disposed in series between the first section and the second section. The radio frequency coupler can further include a third section of the coupled line and a second switch disposed in series between the second section and the third section, in which the second switch is configured to selectively electrically connect the third section to the port configured to provide the indication of power of the radio frequency signal traveling between the power input port and the power output port.

Another aspect of this disclosure is an apparatus that includes a radio frequency coupler. The radio frequency coupler includes a power input port, a power output port, a coupled port, and a coupled line having an adjustable effective length that contributes to a coupling factor of the radio frequency coupler.

The coupled line can include a plurality of sections electrically connectable in series with each other, in which each section of the plurality of sections is selectively electrically coupleable to the coupled port. The radio frequency coupler can further include a switch disposed between two adjacent sections of the plurality of sections, in which the switch is configured to selectively electrically couple the two adjacent sections to each other responsive to a control signal.

Another aspect of this disclosure is an apparatus that includes a radio frequency (RF) coupler and a switch network. The RF coupler has at least a power input port, a power output port, a coupled port, and an isolated port. The switch network is configurable into at least a first state and a second state. The switch network is configured to electrically connect a termination impedance to the isolated port in the first state, and the switch network is configured to decouple an RF signal traveling between the power input

port and the power output port from the isolated port and the coupled port in the second state.

The RF coupler can further include at least one coupling factor switch configured to adjust an effective length of a multi-section coupled line of the RF coupler that is electrically connected to the coupled port. The coupling factor switch can be configured to electrically isolate two adjacent sections of the multi-section coupled line while the switch network operates in the second state.

The switch network can be configured to adjust the termination impedance electrically coupled to the isolated port. The switch network can be configured to adjust the termination impedance electrically coupled to the isolated port responsive to a signal indicative of a selected frequency band.

The apparatus can include a control circuit configured to transition the switch network from the first state to the second state. Alternatively or additionally, the control circuit can be configured to adjust the termination impedance that is electrically connected to the isolated termination based at least partly on a control signal. The control signal can be indicative of at least one of a power mode or a frequency band of operation of the apparatus.

The apparatus can include a termination impedance circuit having a connection node, the switch network can be configurable into a third state, the switch network can be configured to electrically connect the isolated port to the connection node in the first state to electrically connect the termination impedance to the isolated port, and the switch network can be configured to electrically connect the connection node to the coupled port in a third state. The termination impedance can be implemented by at least two switches and at least two passive impedance elements in series between the isolated port and a reference potential.

Another aspect of this disclosure is an apparatus that includes a radio frequency (RF) coupler and a switch network. The RF coupler has at least a power input port, a power output port, a coupled port, an isolated port, a main line, and a coupled line. The switch network is configurable into at least a first state and a second state. The switch network is configured to electrically connect a termination impedance to one of the isolated port or the coupled port in the first state. The switch network is configured to decouple the coupled line from the main line in the second state.

The apparatus can include the termination impedance. The switch network can be configurable into a third state, in which the switch network is configured to electrically connect another termination impedance to the other of the isolated port or the coupled port in the third state. Alternatively, the switch network can be configurable into a third state, in which the switch network is configured to electrically connect the termination impedance to the other of the isolated port or the coupled port in the third state.

The apparatus can include a control circuit in communication with the switch network, and the control circuit can be configured to control the switch network to transition from the first state to the second state.

The apparatus can be configured as a packaged module that includes a package enclosing the RF coupler and the switch network.

The coupled line can include at least a first section and a second section, and the RF coupler can further include a coupling factor switch configured to electrically connect the first section to the second section when on and to electrically decouple the first section from the second section when off.

Another aspect of this disclosure is a radio frequency (RF) coupler, a switch network, and a control circuit. The RF

coupler has at least a power input port, a power output port, a coupled port, an isolated port, a main line electrically connecting the power input port and the power output port, and a coupled line electrically connecting the coupled port and the isolated port. The control circuit is configured to control the switch network to electrically decouple the isolated port and the coupled port from one or more termination impedances in a first mode of operation to decouple the coupled line from the main line. The control circuit is further configured to control the switch network to electrically connect one of the coupled port or the isolated port to at least one of the one or more termination impedances in a second mode of operation to provide an indication of power of the radio frequency signal traveling between the power input port and the power output port in the second mode of operation.

The control circuit can be configured to control the switch network to electrically connect the isolated port to the one of the one or more termination impedances in the second mode of operation, and the indication of power of the radio frequency signal can be representative of forward radio frequency power traveling from the power input port to the power output port. The control circuit can be further configured to control the switch network to electrically connect the coupled port to another of the one or more termination impedances in a third mode of operation to provide an indication of power of the radio frequency signal traveling from the power output port to the power input port.

Another aspect of this disclosure is an apparatus that includes a radio frequency (RF) coupler, a termination impedance circuit, and a switch circuit. The RF coupler has at least a power input port configured to receive an RF signal, a coupled port and an isolated port. The RF coupler is configured to provide an indication of forward RF power of the RF signal at the coupled port in a forward power state and to provide an indication of reverse RF power of the RF signal at the isolated port in a reverse power state. The termination impedance circuit is configured to provide an adjustable termination impedance. The switch circuit is configured to electrically connect the termination impedance circuit to the isolated port in the forward power state and to electrically isolate the termination impedance circuit from the isolated port of the RF coupler in the reverse power state.

The apparatus can include a second termination impedance circuit configured to provide a second adjustable termination impedance, and the switch circuit can be configured to selectively electrically connect the second termination impedance circuit to the coupled port of the RF coupler and to selectively electrically isolate the second termination impedance circuit from the coupled port of the RF coupler.

The switch circuit can be configured to electrically connect the termination impedance circuit to the coupled port when the switch circuit isolates the isolated port from the termination impedance circuit.

The apparatus can include a memory and a control circuit, the control circuit arranged to configure at least a portion of the termination impedance circuit based on data stored in the memory. The apparatus can have a decoupled state in which a coupled line of the RF coupler is decoupled from a transmission line of the RF coupler.

Another aspect of this disclosure is an apparatus that includes a radio frequency (RF) coupler, a termination impedance circuit, and an isolation switch. The RF coupler has at least a power input port, a power output port, a coupled port, and an isolated port. The termination impedance circuit is configured to provide an adjustable termina-

tion impedance. The isolation switch is disposed between the isolated port and the termination impedance circuit. The isolation switch is configured to electrically connect the isolated port to the termination impedance circuit when the isolation switch is on such that the coupled port provides an indication of RF power traveling from the power input port to the power output port. The isolation switch is configured to electrically isolate the isolated port from the termination impedance circuit when the isolation switch is off.

The isolation switch can be a single pole, single throw switch. The isolation switch can include a series-shunt-series circuit topology.

The apparatus can include a second termination impedance circuit configured to provide a second adjustable termination impedance and a second isolation switch, in which the second isolation switch is disposed between the second termination impedance circuit and the coupled port.

The apparatus can include a second isolation switch disposed between the termination impedance circuit and the coupled port, in which the second isolation switch is configured to electrically connect the coupled port to the termination impedance circuit when the second isolation switch is on such that the isolated port provides an indication of RF power traveling from the power output port to the power input port, and the second isolation switch is configured to electrically isolate the coupled port from the termination impedance circuit when the second isolation switch is off.

The termination impedance circuit can include a plurality of switches and a plurality of passive impedance elements. The isolation switch and at least one of the plurality of switches can be in series between each of the plurality of passive impedance elements and the isolated port.

Another aspect of this disclosure is an apparatus that includes a radio frequency (RF) coupler, a termination impedance circuit, and a switch circuit. The RF coupler has at least a power input port configured to receive an RF signal, a coupled port and an isolated port. The RF coupler is configured to provide an indication of forward RF power of the RF signal at the coupled port in a forward power state and to provide an indication of reverse RF power of the RF signal at the isolated port in a reverse power state. The termination impedance circuit is configured to provide an adjustable termination impedance. The switch circuit is configured to selectively electrically connect the termination impedance circuit to a selected port of the RF coupler and to selectively electrically isolate the termination impedance circuit from the selected port of the RF coupler, in which the selected port is the isolated port or the coupled port.

The apparatus can include a second termination impedance circuit configured to provide a second adjustable termination impedance, the selected port being the isolated port, and the switch circuit can be configured to selectively electrically connect the second termination impedance circuit to the coupled port of the RF coupler and to selectively electrically isolate the second termination impedance circuit from the coupled port of the RF coupler.

The selected port can be the isolated port and the switch circuit can be configured to electrically connect the termination impedance circuit to the coupled port when the switch circuit isolates the isolated port from the termination impedance circuit. The apparatus can include a control circuit configured to adjust the adjustable termination impedance based at least partly on an indication of a frequency of the RF signal. The apparatus can include a memory and a control circuit, in which the control circuit is arranged to

configure at least a portion of the termination impedance circuit based on data stored in the memory.

The termination impedance circuit can include a switch disposed between the switch circuit and a passive impedance element. The termination impedance circuit can include at least two switches and at least two passive impedance elements, in which the two switches and the two passive impedance elements are disposed in series between the switch circuit and ground. The termination impedance circuit can include a switch bank of switches disposed in parallel with each other and passive impedance elements, in which each of the switches of the switch bank being disposed between the switch circuit and a respective passive impedance element of the passive impedance elements.

Another aspect of this disclosure is an apparatus that includes a radio frequency (RF) coupler and a termination impedance circuit. The RF coupler has at least a power input port, a power output port, a coupled port, and an isolated port. The termination impedance circuit is configured to provide an adjustable termination impedance. The termination impedance circuit includes two switches and a passive impedance element which are in series between a reference potential and a selected port of the RF coupler. The selected port of the RF coupler is one of the isolated port of the RF coupler or the coupled port of the RF coupler.

The selected port can be the isolated port. The two switches and a passive impedance element are also in series between the coupled port and the reference potential. The reference potential can be ground. The selected port can be the coupled port. The passive impedance element can be coupled in series between the two switches. At least one of the two switches can be configured to change state responsive to a control signal indicative of at least one of a process variation or a frequency band of operation.

The termination impedance circuit can include a second passive impedance element, in which the two switches, the passive impedance element, and the second passive impedance element can be in series between the reference potential and the selected port of the RF coupler. The passive impedance element can be a resistor and the second passive impedance element can be an inductor. Alternatively, the passive impedance element can be a capacitor and the second passive impedance element can be an inductor. As another alternative, the passive impedance element can be a resistor and the second passive impedance element can be a capacitor.

The termination impedance circuit can include a resistor, a capacitor, and an inductor. The termination impedance circuit can include a plurality of passive impedance elements and a bank of switches, in which the plurality of passive impedance elements include the passive impedance element, the bank of switches includes one of the two switches, and the termination impedance circuit includes series combinations of each of the switches of the bank of switches and a respective passive impedance element of the plurality of passive impedance elements arranged in parallel with each other.

Another aspect of this disclosure is a radio frequency (RF) coupler and a termination impedance circuit. The RF coupler has at least a power input port, a power output port, a coupled port, and an isolated port. The termination impedance circuit is configured to provide an adjustable termination impedance. The termination impedance circuit includes a resistor, a switch, and a passive impedance element arranged in series between a reference potential and a selected port of the RF coupler. The selected port is one of the isolated port of the RF coupler or the coupled port of the

RF coupler. The passive impedance element includes at least one of a capacitor or an inductor.

The apparatus can include a second switch, in which the second switch is arranged in series with the switch between the reference potential and the selected port of the RF coupler. The RF coupler can be configured to provide an indication of forward power at the coupled port in a first state and to provide an indication of reflected power at the isolated port in a second state.

Another aspect of this disclosure is an apparatus that includes a radio frequency (RF) coupler and a termination impedance circuit. The RF coupler has at least a power input port, a power output port, a coupled port, and an isolated port. The termination impedance circuit includes passive impedance elements and switches. The switches are configured to selectively electrically connect a subset of the passive impedance elements between the isolated port and ground responsive to one or more control signals. The subset of the passive impedance elements includes two passive impedance elements electrically connected in series with each other between the isolated port and ground. The two passive impedance elements include at least one of a resistor or an inductor.

The subset of passive impedance elements can include at least two of a resistor, a capacitor, or an inductor. At least one of the one or more control signals can be indicative of at least one of a process variation or a frequency band of operation. The apparatus can include an isolation switch disposed between the termination impedance circuit and the isolated port of the RF coupler.

Another aspect of this disclosure is an apparatus that includes a radio frequency (RF) coupler, a termination circuit, a memory, and a control circuit. The RF coupler has at least a power input port, a power output port, a coupled port, and an isolated port. The termination circuit is configured to provide an adjustable termination impedance to at least one of the isolated port or the coupled port. The termination circuit includes switches and passive impedance elements. The memory is configured to store data to set a state of one or more of the switches of the termination circuit. The control circuit is in communication with the memory. The control circuit is configured to provide one or more control signals to set the state of the one or more switches based at least partly on the data stored in the memory.

The data stored in the memory can be indicative of a process variation. Alternatively or additionally, the data stored in the memory can be indicative of an application parameter. The memory can include persistent memory elements, such as fuse elements. the memory can be embodied on same die as at least one of the control circuit or the termination circuit. The apparatus can include a package enclosing the memory and the RF coupler. The apparatus can include a switch disposed between the termination circuit and the RF coupler. The termination impedance circuit can be coupleable to the isolated port in a first state and coupleable to the coupled port in a second state.

Another aspect of this disclosure is an electronically-implemented method that includes: obtaining data indicative of a desired termination impedance at a port of a radio frequency (RF) coupler; and storing the data to physical memory such that the stored data is accessible to a control circuit, in which the control circuit is arranged to configure at least a portion of a termination circuit electrically connected to the port of the RF coupler based at least partly on the data stored to the memory.

The data stored to the physical memory is indicative of a process variation and/or an application parameter. The physical memory can be a persistent memory. The physical memory can include fuse elements. The port can be an isolated port of the RF coupler. Alternatively, the port can be a coupled port of the RF coupler.

The control circuit can be configured to set a state of one or more switches of a termination circuit electrically connected to the port of the RF coupler based at least partly on the data stored to the memory. The method can include setting the state of the one or more switches of the termination circuit based at least partly on the data stored to the memory.

Another aspect of this disclosure is an apparatus that includes a bi-directional radio frequency (RF) coupler, a termination impedance circuit, and a switch circuit having at least a first state and a second state. The switch circuit is configured to electrically connect the termination impedance circuit to different ports of the bi-directional RF coupler in different states.

The different ports can include an isolated port of the RF coupler and a coupled port of the RF coupler.

Another aspect of this disclosure is an apparatus that includes a bi-directional radio frequency (RF) coupler having at least a power input port, a power output port, a coupled port, and an isolated port. The apparatus also includes one or more termination adjustable impedance circuits configured to present a first impedance to the isolated port in a first mode of operation and to present a second termination impedance to the coupled port in a second mode of operation.

The apparatus can include a control circuit configured to cause the one or more termination adjustable circuits to change state.

The one or more adjustable termination circuits can include a first termination impedance circuit to present the first termination impedance and a second termination impedance circuit to present the second termination impedance. Alternatively, the one or more adjustable termination circuits can include a shared termination impedance circuit to present the first termination impedance and the second termination impedance.

The one or more termination adjustable circuits can include a switch network and passive impedance elements configured to provide the first termination impedance. The passive impedance elements can include a plurality of resistors each having a first end electrically connected to a respective switch of the switch network and a second end electrically connected to ground.

The one or more termination adjustable circuits can include at least one of an adjustable resistance, an adjustable capacitance, or an adjustable inductance. The one or more adjustable termination impedance circuits can be configured to present the first impedance with at least two switches and at least two passive impedance elements in series between the isolated port and ground.

The one or more termination adjustable circuits can be configured to adjust the second termination impedance based at least partly on a control signal indicative of a frequency band of a radio frequency signal provided to the RF coupler. Alternatively or additionally, the one or more termination adjustable circuits can be configured to adjust the second termination impedance based at least partly on a control signal indicative of a power mode of the apparatus.

The apparatus can include an isolation switch disposed between the one or more adjustable termination impedance circuits and the isolated port, in which the isolation switch

is configured to electrically connect the isolated port to at least one of the one or more adjustable impedance circuits when on and to electrically isolate the isolated port from the one or more adjustable impedance circuits when off. The apparatus can further include a second isolation switch disposed between the one or more adjustable termination impedance circuits and the coupled port, in which the second isolation switch is configured to electrically connect the coupled port to at least one of the one or more adjustable termination impedance circuits when on and to electrically isolate the coupled port from the one or more adjustable termination impedance circuits when off.

Another aspect of this disclosure is an apparatus that includes a bi-directional RF coupler, a termination impedance circuit, and a switch circuit. The bi-directional RF coupler has at least a power input port, a power output port, a coupled port, and an isolated port. The switch circuit has at least a first state and a second state. The switch circuit is configured to electrically connect the termination impedance circuit to the isolated port in the first state and to electrically connect the termination impedance circuit to the coupled port in the second state.

The termination impedance circuit can be configured to provide an adjustable termination impedance. The termination impedance circuit can include a plurality of switches and a plurality of passive impedance elements. At least one of the switches of the termination impedance circuit and at least one switch of the switch circuit are in series between the isolated port of the RF coupler and each of the passive impedance elements of the termination impedance circuit.

Another aspect of this disclosure is an apparatus that includes a bi-directional radio frequency (RF) coupler, a first adjustable termination impedance circuit, and a second adjustable termination impedance circuit that is separate from the first adjustable termination impedance circuit. The bi-directional RF coupler has at least a power input port, a power output port, a coupled port, and an isolated port. The first adjustable termination impedance circuit is configured to provide a first termination impedance to the isolated port when a portion of RF power traveling from the power input port to the power output port is being provided to the coupled port. The first adjustable impedance termination circuit is configured to change state to adjust the first termination impedance. The second adjustable termination impedance circuit is configured to provide a second termination impedance to the coupled port when a portion of RF power traveling from the power output port to the power input port is being provided to the isolated port. The second adjustable termination impedance circuit is configured to change state to adjust the second termination impedance.

The first adjustable termination impedance circuit can include a first switch network and a first termination impedance circuit to provide the first termination impedance. The first adjustable termination impedance circuit can include at least one of an adjustable resistance, an adjustable capacitance, or an adjustable inductance. The second adjustable termination impedance circuit can be configured to adjust the second termination impedance based at least partly on a control signal indicative of at least one of a frequency band of a radio frequency signal provided to the RF coupler or a power mode of the apparatus.

For purposes of summarizing the disclosure, certain aspects, advantages and novel features of the inventions have been described herein. It is to be understood that not necessarily all such advantages may be achieved in accordance with any particular embodiment of the invention. Thus, the inventions may be embodied or carried out in a

11

manner that achieves or optimizes one advantage or group of advantages as taught herein without necessarily achieving other advantages as may be taught or suggested herein.

BRIEF DESCRIPTION OF THE DRAWINGS

Embodiments of this disclosure will now be described, by way of non-limiting example, with reference to the accompanying drawings.

FIG. 1 is a schematic block diagram in which a radio frequency coupler is configured to extract a portion of power of a radio frequency signal traveling between a power amplifier and an antenna.

FIG. 2 is a schematic block diagram in which a radio frequency coupler is configured to extract a portion of power of a radio frequency signal traveling between an antenna switch module and an antenna.

FIG. 3A is a schematic diagram of an electronic system that includes a radio frequency coupler and an adjustable termination impedance circuit according to an embodiment. FIG. 3B is a graph illustrating a coupling signal at a coupled port and a signal at an isolated port for different termination impedance settings of the radio frequency coupler illustrated in FIG. 3A. FIG. 3C is a graph illustrating a relationship of directivity over frequency for different termination impedance settings of the radio frequency coupler illustrated in FIG. 3A.

FIG. 4 is a schematic diagram illustrating the electronic system of FIG. 3A configured in a different state than in FIG. 3A. In FIG. 4, the electronic system is configured to extract a portion of power of a radio frequency signal traveling in an opposite direction than in FIG. 3A.

FIG. 5 is a schematic diagram illustrating the electronic system of 3A configured in a different state than in FIG. 3A. In FIG. 5, the electronic system is configured in a decoupled state.

FIG. 6A is a schematic diagram illustrating that the termination impedance circuit of FIG. 3A can be implemented by an adjustable resistance circuit, an adjustable capacitance circuit, and/or an adjustable inductance circuit. FIG. 6B is a schematic diagram illustrating that the termination impedance circuit of FIG. 3A can include a plurality of resistors.

FIG. 7A is a schematic diagram of a radio frequency coupler having a coupled line with an adjustable length electrically connected to a coupled port according to an embodiment. FIG. 7B is a graph illustrating an insertion loss curve for the radio frequency coupler shown in FIG. 7A. FIG. 7C is a graph illustrating a coupling factor curve for the radio frequency coupler shown in FIG. 7A.

FIG. 8A is a schematic diagram of the radio frequency coupler of FIG. 7A configured in a second state in which two of three sections of the coupled line are electrically connected to the coupled port. FIG. 8B is a graph illustrating an insertion loss curve for a radio frequency coupler in the state shown in FIG. 8A. FIG. 8C is a graph illustrating a coupling factor curve for the radio frequency coupler in the state shown in FIG. 8A.

FIG. 9A is a schematic diagram of the radio frequency coupler of FIG. 7A configured in a third state in which one of three sections of the coupled line is electrically connected to the coupled port. FIG. 9B is a graph illustrating an insertion loss curve for a radio frequency coupler in the state shown in FIG. 9A. FIG. 9C is a graph illustrating a coupling factor curve for the radio frequency coupler in the state shown in FIG. 9A.

12

FIG. 10A is a schematic diagram of the radio frequency coupler of FIG. 7A configured in a fourth state in which the coupled line is decoupled from a main line. FIG. 10B is a graph illustrating an insertion loss curve for a radio frequency coupler in the state shown in FIG. 10A. FIG. 10C is a graph illustrating a coupling factor curve for the radio frequency coupler in the state shown in FIG. 10A.

FIG. 11A is graph with a curve of insertion loss over frequency for an RF coupler having a continuous coupled line. FIG. 11B is a graph with curves of insertion loss over frequency for an RF coupler having a multi-section coupled line.

FIG. 12A is graph with a curve of coupling factor over frequency for an RF coupler having a continuous coupled line. FIG. 12B is a graph with curves of coupling factor over frequency for an RF coupler having a multi-section coupled line.

FIG. 13A is a schematic diagram of a radio frequency coupler with a multi-section coupled line having a plurality of termination impedances coupleable to each section, according to an embodiment. FIG. 13B is a graph illustrating curves associated with the radio frequency coupler of FIG. 13A corresponding to two different termination impedances. FIG. 13C is a schematic diagram of a radio frequency coupler with a multi-section coupled line having a plurality of termination impedances coupleable to each section, according to another embodiment.

FIG. 14 is a schematic diagram of a radio frequency coupler having cascaded sections in a coupled line, according to an embodiment.

FIG. 15 is a schematic diagram of a radio frequency coupler having multiple layers in which multiple coupled line sections can share the same main line, according to an embodiment.

FIG. 16A is a schematic diagram of a radio frequency coupler, a termination impedance circuit configured to provide an adjustable termination impedance, and an isolation switch coupled between the radio frequency coupler and the termination impedance circuit, according to an embodiment. FIG. 16B is a graph illustrating a coupling signal at a coupled port and a signal at an isolated port optimized for two different frequencies for the radio frequency coupler illustrated in FIG. 16A.

FIG. 17A is a schematic diagram of a radio frequency coupler, a termination impedance circuit configured to provide an adjustable termination impedance, and an isolation switch coupled between the radio frequency coupler and the termination impedance circuit, according to another embodiment. FIG. 17B is a graph illustrating a coupling signal at a coupled port and a signal at an isolated port optimized for two different frequencies for the radio frequency coupler illustrated in FIG. 17A.

FIG. 18 is a flow diagram of an illustrative process of setting a state of a switch in a termination impedance circuit, according to an embodiment.

FIG. 19A is a schematic diagram of a radio frequency coupler and a termination impedance circuit electrically coupleable to an isolated port or a coupled port of the radio frequency coupler by way of switches, according to an embodiment. FIGS. 19B and 19C are schematic diagrams of switches of FIG. 19A according to certain embodiments.

FIG. 20 is a schematic diagram of an electronic system that includes a radio frequency coupler having a multi-section coupled line, termination impedance circuits, and switches configured to selectively electrically connect one of the termination impedance circuits to a selected section of the multi-section coupled line, according to an embodiment.

13

FIG. 21 is a schematic diagram of an electronic system that includes a radio frequency coupler having a multi-section coupled line, termination impedance circuits, and switches configured to selectively electrically connect one of the termination impedance circuits to a selected section of the multi-section coupled line, according to another embodiment.

FIG. 22A is a schematic diagram of an electronic system that includes a radio frequency coupler having a multi-section coupled line, termination impedance circuits, and switches configured to selectively electrically connect a selected termination impedance circuit of the termination impedance circuits to a selected section of the multi-section coupled line, according to another embodiment.

FIG. 22B is a schematic diagram of an electronic system that includes a radio frequency coupler having a multi-section coupled line, termination impedance circuits, and switches configured to selectively electrically connect a selected termination impedance circuit of the termination impedance circuits to a selected section of the multi-section coupled line, according to another embodiment.

FIG. 22C is a schematic diagram of an electronic system that includes a radio frequency coupler having a multi-section coupled line, termination impedance circuits, and switches configured to selectively electrically connect a termination impedance circuit to a selected section of the multi-section coupled line, according to another embodiment.

FIG. 23A is a schematic diagram of an electronic system that includes a radio frequency coupler having a multi-section coupled line, termination impedance circuits, and switches configured to selectively electrically connect a selected termination impedance circuit of the termination impedance circuits to a selected section of the multi-section coupled line, according to another embodiment.

FIG. 23B is a schematic diagram of an electronic system that includes a radio frequency coupler having a multi-section coupled line, termination impedance circuits, and switches configured to selectively electrically connect a selected termination impedance circuit of the termination impedance circuits to a selected section of the multi-section coupled line, according to another embodiment.

FIG. 24 is a schematic diagram of an electronic system that includes a radio frequency coupler having a multi-section coupled line, a shared termination impedance circuit, and switches configured to selectively electrically connect the shared termination impedance circuit to a selected section of the multi-section coupled line, according to another embodiment.

FIG. 25A is a schematic diagram of an electronic system that includes a radio frequency coupler having a multi-section coupled line, a plurality of termination impedance circuits, and a switch network, according to an embodiment. FIG. 25B illustrates an example termination impedance circuit of FIG. 25A, according to an embodiment.

FIGS. 26A to 26C illustrate example modules that can include any of the radio frequency couplers discussed herein. FIG. 26A is a block diagram of a packaged module that includes a radio frequency coupler. FIG. 26B is a block diagram of a packaged module that includes a radio frequency coupler and an antenna switch module. FIG. 26C is a block diagram of a packaged module that includes a radio frequency coupler, an antenna switch module, and a power amplifier.

FIG. 27 is a schematic block diagram of an example wireless device that can include any of the radio frequency couplers discussed herein.

14

DETAILED DESCRIPTION OF CERTAIN EMBODIMENTS

The following detailed description of certain embodiments presents various descriptions of specific embodiments. However, the innovations described herein can be embodied in a multitude of different ways, for example, as defined and covered by the claims. In this description, reference is made to the drawings where like reference numerals can indicate identical or functionally similar elements. It will be understood that elements illustrated in the figures are not necessarily drawn to scale. Moreover, it will be understood that certain embodiments can include more elements than illustrated in a drawing and/or a subset of the elements illustrated in a drawing. Further, some embodiments can incorporate any suitable combination of features from two or more drawings.

Conventional radio frequency (RF) couplers can have limitations related to a fixed coupling factor at a given frequency. The fixed coupling factor at frequency F can be represented by the coupling factor at frequency A plus $20 \log(A/F)$. For smaller absolute coupling factors, greater coupling effects can be present. At higher frequencies, the coupling effects can be greater. Conventional RF couplers can also have a fixed insertion loss at a given frequency. Insertion loss can be a function of the coupling factor plus resistive loss of the main transmission line of the RF coupler that electrically connects a power input port to a power output port.

Directivity of an RF coupler can be dependent on termination impedance at the isolated port. In conventional RF couplers, termination impedance is typically at a fixed impedance value that provides a desired directivity for only a particular frequency bandwidth. However, with a fixed termination impedance, the radio frequency coupler will not have a desired directivity when an RF signal is outside of the particular frequency band. Thus, when operating in a different frequency band outside of the particular frequency band, directivity will not be optimized.

Flattening a coupling factor over frequency can be desirable. Flattening the coupling factor over frequency has been implemented by inserting a post-RF coupler RLC network to offset and/or compensate for an increased coupling slope of the RF coupler. This brute-force method can flatten coupling factor over a relatively wide frequency range. However, this method can adversely impact insertion loss in a main signal path since the RLC network can be lossy. As a result, for a desired coupling factor, it may be desirable for the RF coupler to have even more coupling to compensate for the loss of the RLC network. Thus, the insertion loss can be increased in the main signal path.

In addition, traditional RF couplers add insertion loss to a signal path even when unused. This can degrade an RF signal even when the RF coupler is not being used to detect power.

Performance of an RF coupler can be impacted by a variety of factors, such as process variations and/or variations in source impedance. As discussed above, typically a termination impedance used to terminate the isolated port of a conventional RF coupler is a fixed impedance that is not adjustable. Accordingly, a desired level of directivity may only be achieved for a selected frequency band and/or for a certain bandwidth with a fixed termination impedance. Process variations and/or variations in source impedance can be problematic with fixed termination impedances. Moreover, to avoid variation in semiconductor parameters, some termination impedance circuits have been implemented by

external passive impedance elements formed by a non-semiconductor process. While such external passive impedance elements can lead to reduced variation in termination impedance values, these external passive impedance elements can be expensive and/or consume a larger area relative to semiconductor based passive impedance elements.

Process variations can impact performance of an RF coupler. For instance, the directivity of an RF coupler, such as a bi-directional RF coupler, can be dependent on the termination impedance at an isolated port of the coupler and a source impedance presented to a power input port of the coupler. Due to imperfections in semiconductor manufacturing processes, there can be process variations present in a termination impedance circuit for providing a termination impedance to a port of an RF coupler. Process variations can affect values of a resistance, a capacitance, an inductance, or any combination thereof in the termination impedance circuit. Such process variations in a termination impedance circuit can include, for example, variations in semiconductor field effect transistor (FET) on resistance and/or off capacitance, polysilicon resistor resistance, metal-insulator-metal (MIM) capacitor capacitance, inductor inductance, the like, or any combination thereof. Alternatively or additionally, process variations can affect a width of a coupled line and/or a spacing of the coupled line to the main line, which can change a characteristic of the RF coupler. Such variations in the coupled line can affect performance of the RF coupler and/or a termination impedance circuit. Typically, a distribution of process variations in the termination impedance circuit and/or coupled line can be approximated by a normal distribution with 3-sigma being about 10% to about 15%.

Variations in source impedance can impact performance of an RF coupler. For instance, the source impedance can deviate from a particular value for which a termination impedance circuit is configured to optimize directivity. When an RF coupler is in communication with another component (e.g., an RF power amplifier, an antenna switch, a diplexer, or a filter, etc.) configured to provide an RF signal to the RF coupler, the source impedance presented to the RF coupler may deviate from 50 Ohms. Such deviation can reduce directivity of the RF coupler relative to a 50 Ohm source impedance when the RF coupler is optimized for a 50 Ohm source impedance.

Aspects of this disclosure relate to adjusting a termination impedance electrically connected to a radio frequency coupler and/or adjusting an effective length of a coupled line electrically connected to a port of a radio frequency coupler. A variety of termination impedance circuits configured to provide adjustable termination impedances are disclosed. Such circuits can implement desired characteristics of an RF coupler, such as a desired directivity. Switches can adjust a coupling factor of an RF coupler by adjusting an effective length of a multi-section coupled line that is electrically connected to a coupled port of the RF coupler. RF couplers disclosed herein can be configured into a decoupled state to cause insertion loss associated with such RF couplers to be reduced when the RF couplers are not in use. In certain embodiments, an isolation switch is configured to selectively isolate an adjustable termination impedance circuit from a port of a radio frequency coupler, such as a coupled port or an isolated port. Alternatively or additionally, according to some embodiments, a switch circuit is configured to selectively electrically couple a termination impedance circuit to an isolated port of an RF coupler in one state and to selectively electrically couple the same termination impedance circuit to a coupled port of the RF coupler in another

state. In various embodiments, a value indicative of a desired termination impedance can be stored in a memory and a state of a switch in a termination impedance circuit can be set based at least partly on the stored value. Any of the principles and advantages discussed herein can be applied to any suitable radio frequency coupler including, for example, a direction coupler, a bi-directional coupler, a dual-directional coupler, a multi-band coupler (e.g., a dual-band coupler), etc.

Adjusting the termination impedance electrically connected to a port of the radio frequency coupler can improve directivity of the radio frequency coupler by providing a desired termination impedance for certain operating conditions, such as a frequency band of a radio frequency signal provided to the radio frequency coupler or a power mode of an electronic system that includes the radio frequency coupler. In certain embodiments, a switch network can selectively electrically couple different termination impedances to the isolated port of the radio frequency coupler responsive to one or more control signals. The switch network can adjust the termination impedance of the radio frequency coupler to improve directivity across multiple frequency bands. The switch network can include switches between termination impedances and both the isolated port and the coupled port. Such an RF coupler can have a termination impedance provided to the isolated port for providing an indication of forward RF power in one state and have a termination impedance provided to the coupled port for providing an indication of reverse RF power in another state.

In certain embodiments, a termination impedance circuit including plurality of switches can adjust the termination impedance provided to an isolated port and/or a coupled port of an RF coupler by selectively providing resistance, capacitance, inductance, or any combination thereof in a termination path. The termination impedance circuit can provide any suitable termination impedance by selectively electrically coupling passive impedance elements in series and/or in parallel in the termination path. The termination impedance circuit can thereby provide a termination impedance having a desired impedance value. The termination impedance circuit can compensate for process variations and/or source impedance variations, for example. In some embodiments, data indicative of a desired termination impedance can be stored in memory and a state of at least one of the switches of the plurality of switches can be set based at least partly on the data stored in the memory. In some implementations, the memory can include persistent memory, such as fuse elements (e.g., fuses and/or antifuses), to store the data.

According to various embodiments, a switch can be disposed between a port of an RF coupler (e.g., a coupled port or an isolated port) and an adjustable termination impedance circuit. The switch can electrically isolate tuning elements (e.g., switches) of the adjustable termination impedance circuit from the port of the RF coupler when the adjustable termination impedance circuit is not providing a termination impedance to the port of the RF coupler. This can reduce loading effects, such as off capacitances of switches of the adjustable termination impedance circuit, on the port of the RF coupler. Accordingly, the switch can cause insertion loss on the port of the RF coupler to be decreased.

In accordance with some embodiments, a termination impedance circuit can be shared by an isolated port and a coupled port of a bi-directional coupler. This can reduce the area relative to having separate termination impedance circuits for the isolated port and the coupled port. Only one of the isolated port or the coupled port can be provided with a termination impedance at a time to provide an indication of

RF power. Accordingly, a switch circuit can selectively electrically connect the termination impedance circuit to the isolated port and selectively electrically connect the termination impedance circuit to the coupled port such that no more than one of the isolated port or the coupled port is electrically connected to the termination impedance circuit at a time. To electrically isolate the coupled port and the isolated port, the switch circuit can include high isolation switches. Each of the high isolation switches can include a series-shunt-series circuitry topology, for example. The isolation between the coupled port and the isolated port provided by the high isolation switches can be greater than a target directivity.

An effective length of a coupled line can be a length of the coupled line that contributes to the coupling factor of the RF coupler. For instance, the effective length of the coupled line can be a length of the coupled line in an electrical path between a termination impedance and a port of an RF coupler configured to provide an indication of power traveling between a power input port and a power output port. Adjusting the effective length of the coupled line can adjust a coupling factor of the radio frequency coupler. Accordingly, a radio frequency coupler with an adjustable effective length of the coupled line can have a desired coupling factor. At the same time, the insertion loss of the main line should not be increased. In certain embodiments, the radio frequency coupler can have a coupled line that includes multiple sections and one or more switches to selectively electrically couple one section of the coupled line to a port, such as the coupled port, of the radio frequency coupler. For instance, a switch can be in series between two sections of the coupled line and the switch can either electrically couple or decouple two sections of the coupled line from each other. A switch network can selectively electrically couple a selected termination impedance to a particular section of the coupled line depending on the state of the radio frequency coupler. The switch network can optimize directivity of the radio frequency coupler. The switch network can present a termination impedance to the coupled port of the radio frequency coupler in one state and present a termination impedance to the isolated port of the radio frequency coupler in another state. Any of the principles and advantages of the termination impedance circuits discussed herein can be applied in connection with a coupled line having an effective length configured to be adjusted.

The radio frequency couplers discussed herein can have a decoupled state in which the coupled line is decoupled from a main line. The decoupled state can provide a minimal insertion loss in a main signal line when the radio frequency coupler is unused.

Embodiments discussed herein can advantageously provide an improved directivity for a radio frequency coupler by providing a termination impedance that is selected for particular operating conditions, such as a particular frequency band of a radio frequency signal provided to the radio frequency coupler. Alternatively or additionally, embodiments discussed herein can provide improved main line insertion loss by adjusting an effective length of the coupled line to adjust coupling factor. This can avoid over coupling and subsequent attenuation. By adjusting the effective length of the coupled line, a desired coupling factor of the radio frequency coupler can be set. In certain embodiments, the radio frequency couplers discussed herein have a decoupled state that can minimize loss due to coupling effects when the radio frequency coupler is unused.

FIG. 1 is a schematic block diagram in which a radio frequency coupler is configured to extract a portion of power

of a radio frequency signal traveling between a power amplifier and an antenna. As illustrated, a power amplifier **10** receives an RF signal and provides an amplified RF signal to an antenna **30** by way of an RF coupler **20**. It will be understood that additional elements (not illustrated) can be included in the electronic system of FIG. 1 and/or a subcombination of the illustrated elements can be implemented.

The power amplifier **10** can amplify an RF signal. The power amplifier **10** can be any suitable RF power amplifier. For instance, the power amplifier **10** can be one or more of a single stage power amplifier, a multi-stage power amplifier, a power amplifier implemented by one or more bipolar transistors, or a power amplifier implemented by one or more field effect transistors. The power amplifier **10** can be implemented on a GaAs die, CMOS die, or a SiGe die, for example.

The RF coupler **20** can extract a portion of the power of the amplified RF signal traveling between the power amplifier **10** and the antenna **30**. The RF coupler **20** can generate an indication of forward RF power traveling from the power amplifier **10** to the antenna **30** and/or generate an indication of reflected RF power traveling from the antenna **30** to the power amplifier **10**. An indication of power can be provided to an RF power detector (not illustrated). The RF coupler **20** can have four ports: a power input port, a power output port, a coupled port, and an isolated port. In the configuration of FIG. 1, the power input port can receive the amplifier RF signal from the power amplifier **10** and the power output port can provide the amplified RF signal to the antenna **30**. A termination impedance can be provided to either the isolated port or to the coupled port. In a bi-directional RF coupler, a termination impedance can be provided to the isolated port in one state and a termination impedance can be provided to the coupled port in another state. When a termination impedance is provided to the isolated port, the coupled port can provide a portion of the power of RF signal traveling from the power input port to the power output port. Accordingly, the coupled port can provide an indication of forward RF power. When a termination impedance is provided to the coupled port, the isolated port can provide a portion of the power of RF signal traveling from the power output port to the power input port. Accordingly, the isolated port can provide an indication of reverse RF power. The reverse RF power can be RF power reflected from the antenna **30** back to the RF coupler **20**.

The antenna **30** can transmit the amplified RF signal. For instance, when the electronic system illustrated in FIG. 1 is included in a cellular phone, the antenna **30** can transmit an RF signal from the cellular phone to a base station.

FIG. 2 is a schematic block diagram in which a radio frequency coupler is configured to extract a portion of power of a radio frequency signal traveling between an antenna switch module and an antenna. The system of FIG. 2 is like the system of FIG. 1, except that an antenna switch module **40** is included in a signal path between the power amplifier **10** and the RF coupler **20**. The antenna switch module **40** can selectively electrically connect the antenna **30** to a selected transmit path. The antenna switch module **40** can provide a number of switching functionalities. The antenna switch module **40** can include a multi-throw switch configured to provide functionalities associated with, for example, switching between transmission paths associated with different frequency bands, switching between transmission paths associated with different modes of operation, switching between transmission and/or receiving modes, or any combination thereof. It will be understood that additional ele-

ments (not illustrated) can be included in the electronic system of FIG. 2 and/or a subcombination of the illustrated elements can be implemented. In another implementation (not illustrated), an RF coupler can be included in a signal path between a power amplifier and an antenna switch module.

Referring to FIG. 3A, an electronic system that includes a radio frequency coupler **20a** and an adjustable termination impedance circuit according to an embodiment will be described. When the electronic system is in the state illustrated in FIG. 3A, a portion of RF power traveling from the power input port to the power output port is being provided to the coupled port. The portion of RF power provided to the coupled port of the RF coupler **20a** in FIG. 3A is representative of forward RF power. An indication of the forward RF power at the coupled port of the RF coupler **20a** can be indicative of power of a signal generated by a power amplifier provided to an antenna, for example. FIG. 3A illustrates an electronic system that includes an RF coupler **20a**, a first switch network **50**, first termination impedance elements **52**, a second switch network **54**, second termination impedance elements **56**, and a control circuit **58**. The electronic system of FIG. 3A can include more elements than illustrated and/or a subcombination of the illustrated elements can be implemented.

The RF coupler **20a** is an example of the RF coupler **20** of FIGS. 1 and 2. The RF coupler **20a** can include two parallel or overlapped transmission lines, such as microstrips, strip lines, coplanar lines, etc. In some embodiments, the RF coupler **20a** can include two inductors, such as two transformers, in place of the two transmission lines. The two transmission lines or inductors can implement a main line and a coupled line. The main line can provide the majority of the signal from the RF power input to the RF power output. The coupled line can be used to extract a portion of the power traveling between the RF power input and the RF power output.

In FIG. 3A, the first switch network **50** and the first termination impedance elements **52** can together implement a first adjustable termination impedance circuit. The first adjustable termination impedance circuit can provide a selected termination impedance to the isolated port of the RF coupler **20a**. The second switch network **54** and the second termination impedance elements **56** can together implement a second adjustable termination impedance circuit. The second adjustable termination impedance circuit can provide a selected termination impedance to the coupled port of the RF coupler **20a** as will be discussed in more detail with reference to FIG. 4. While the first adjustable termination impedance circuit and the second adjustable termination impedance circuit of FIG. 3A each includes switches and termination impedances electrically connected to respective switches, the first adjustable termination impedance circuit and/or the second adjustable termination impedance circuit can be implemented by any suitable adjustable termination impedance circuit.

The isolated port of the RF coupler **20a** can be electrically connected to one or more switches to adjust the termination impedance provided to the isolated port. As illustrated, the first switch network **50** includes impedance select switches **61**, **62**, and **63** to selectively electrically couple termination impedances **71**, **72**, and **73**, respectively, of the first termination impedance elements **52** to the isolated port of the RF coupler **20a**. The illustrated first switch network **50** also includes a mode select switch **64** that can selectively provide

a reverse coupled output from the RF coupler **20a** when the RF coupler **20a** is being used to provide an indication of reverse RF power.

Each of the switches of the first switch network **50** can electrically couple nodes when on and electrically isolate nodes when off. The first switch network **50** can include any suitable switches to implement the impedance select switches **61**, **62**, and **63** and the mode select switch **64**. For example, each of the illustrated switches in the first switching network **50** can include a semiconductor field effect transistor (FET). Such a FET can be biased in the linear mode, for example. When the FET is on, the FET can be in a short circuit or low loss mode that electrically connects a source and a drain of the FET. When the FET is off, the FET can be in an open circuit or high loss mode that electrically isolates the source and the drain of the FET. Other suitable switches can alternatively or additionally be implemented. Moreover, while three impedance select switches **61**, **62**, and **63** are illustrated in FIG. 3A, any suitable number of impedance selected switches can be implemented. In some instances, only one impedance select switch may be implemented. In some other instances, two impedance selected switches can be implemented or more than three impedance select switches can be implemented.

The impedance select switches **61**, **62**, and **63** and the termination impedances **71**, **72**, and **73** can be used to achieve a desired directivity of the RF coupler **20a**. For example, different termination impedances can be selectively electrically coupled to the isolated port when the RF signal to the RF coupler **20a** is within corresponding different frequency bands. As an illustrative example, a first termination impedance **71** can be electrically coupled to the isolated port for a first frequency band, a second termination impedance **72** can be electrically coupled to the isolated port for a second frequency band, and a third termination impedance **73** can be electrically coupled to the isolated port for a third frequency band.

Table 1 below summarizes states of the impedance select switches **61**, **62**, and **63** and the corresponding termination impedance for various frequency bands according to an embodiment. As shown in FIG. 3A, the first impedance select switch **61** can electrically connect the first termination impedance **71** to the isolated port of the RF coupler **20a**. This can optimize the directivity for a particular frequency band.

TABLE 1

| Forward Power States | | | | |
|----------------------|-----------------------|------|------|------|
| Frequency Band | Termination Impedance | S 61 | S 62 | S 63 |
| A | 2A | On | Off | Off |
| B | 2B | Off | On | Off |
| C | 2C | Off | Off | On |

The impedance select switches **61**, **62**, and **63** can be controlled so as to provide any suitable combination of termination impedances **71**, **72**, and/or **73** to the isolated port of the RF coupler **20a**. For example, the impedance select switches **61**, **62**, and **63** can be configured into any combination or subcombination of the states shown in Table 2 below. Moreover, the principles and advantages discussed herein can be applied to any suitable number of impedance select switches and corresponding termination impedances.

TABLE 2

| Forward Power States | | | | |
|----------------------|-----------------------|------|------|------|
| Frequency Band | Termination Impedance | S 61 | S 62 | S 63 |
| A | 2A | On | Off | Off |
| B | 2B | Off | On | Off |
| C | 2C | Off | Off | On |
| D | 2A + 2B | On | On | Off |
| E | 2A + 2C | On | Off | On |
| F | 2B + 2C | Off | On | On |
| G | 2A + 2B + 2C | On | On | On |

Alternatively or additionally, a particular termination impedance or combination of termination impedances can be selected for a particular power mode of operation. Having a particular impedance for a particular power mode and/or frequency band can improve the directivity of the RF coupler **20a**, which can aid in improving, for example, the accuracy of power measurements associated with the RF coupler **20a**. A particular termination impedance or combination of termination impedances can be selected for any suitable application parameter(s) and/or any suitable indication of operating condition(s).

The first termination impedance elements **52** of FIG. **3A** include a termination impedance electrically connected to each impedance select switch of the first switching network. The termination impedances **71**, **72**, and **73** can be, for example, resistive, capacitive, and/or inductive loads selected to achieve a desired termination impedance. Such a desired termination impedance can be selected for a particular frequency band and/or power mode. One or more of the termination impedances can be a passive impedance element electrically coupled between a mode select switch and a ground potential. For example, a termination impedance can be implemented by a resistor electrically coupled between an impedance select switch and ground. One or more termination impedances can include any suitable combination of series and/or parallel passive impedance elements. For instance, a termination impedance can be implemented by a capacitor and a resistor in series between an impedance select switch and a ground potential. More detail regarding example termination impedance elements will be provided in connection with FIGS. **6A** and **6B**.

The control circuit **58** can control the impedance select switches **61**, **62**, and **63** such that a desired terminating impedance is provided to the isolated port of the RF coupler **20a** when the electronic system is in a state to provide an indication of forward RF power. The control circuitry **58** can include any suitable circuitry for selectively opening and closing one or more of the impedance select switches **61**, **62**, **63** to achieve the desired termination impedance at the isolated terminal. For example, the control circuit **58** can configure the impedance select switches **61**, **62**, and **63** into any of the states illustrated in Table 1 and/or Table 2.

The control circuit **58** can receive a first signal indicative of whether to measure forward power or reverse power and a second signal indicative of a mode of operation, such as a band select signal. From the received signals, the control circuit **58** can control the first switch network **50** to provide a selected termination impedance to isolated port of the RF coupler **20a**. The selected termination impedance can be implemented by any suitable combination of the termination impedances **71**, **72**, **73**. From the received signals, the control circuit **58** can control the second switch network **54** to provide a selected termination impedance to the coupled port of the RF coupler **20a** for measuring reverse power. The

control circuit **58** can control the mode select switches **64** and **68** based on the state of the first signal.

In some states, such as the states illustrated in FIGS. **4** and **5**, the control circuit **58** can decouple the isolated port from all termination impedances of the first termination impedance elements **52**.

When the electronic system is in the state illustrated in FIG. **3A**, the control circuit **58** controls the switch network **50** to electrically connect the first terminating impedance **71** to the isolated port of the RF coupler **20a** by way of the first impedance select switch **61** while electrically isolating the other terminating impedances from the isolated port using the other impedance select switches **62** and **63**. The control circuit **58** can include digital logic, such as a decoder, for operating the impedance select switches **61**, **62**, **63**. The digital logic can operate on any suitable power supply, including, for example, an output voltage of a charge pump or a battery voltage. The control circuit **58** can also control the mode select switch **64** of the first switch network **50** such that the isolated port is decoupled from a reflected power output in the state illustrated in FIG. **3A**. When operating in the state illustrated in FIG. **3A**, the control circuit **58** provides input signals to the second switch network **54** such that the mode select switch **68** electrically connects the coupled port to a forward power output and the impedance select switches **65**, **66**, and **67** electrically isolate the coupled port from the terminating impedances **75**, **76**, and **77**, respectively.

FIG. **3B** is a graph illustrating a coupling signal at a coupled port and a signal at an isolated port for the RF coupler **20a** arranged as illustrated in FIG. **3A**. FIG. **3B** shows that different termination impedances provided to the isolated port of the RF coupler **20a** can optimize a minimum amount of signal at the isolated port at corresponding different frequencies.

FIG. **3C** is a graph illustrating a relationship of directivity over frequency corresponding to the curves shown in FIG. **3B**. Directivity can represent a measure of a power of the coupling signal minus a measure of a power of the signal at the isolated port. Higher directivities can be more desirable. As shown in FIG. **3C**, directivity can be optimized at selected frequencies by providing particular termination impedances to the isolated port of the RF coupler **20a**.

FIG. **4** is a schematic diagram illustrating the electronic system of FIG. **3A** configured in a different state than in FIG. **3A** in which a portion of power of a radio frequency signal traveling in an opposite direction is extracted. Instead of providing an indication of forward power at a forward coupled output as shown in FIG. **3A**, the electronic system can provide an indication of reverse power at a reverse coupled output as shown in FIG. **4**. Accordingly, the RF coupler **20a** can be used to detect reverse power, such as power reflected back from the antenna **30** in FIG. **1** and/or FIG. **2**. To provide an indication of reverse power, a termination impedance can be provided to the coupled port of the RF coupler **20a**. Having switch networks coupled to the coupled port and the isolated port of the RF coupler **20a** can enable the RF coupler **20a** to be bi-directional.

The second switch network **54** can electrically couple a selected termination impedance of the second termination impedance elements **56** to the coupled port of the RF coupler **20a**. The second switch network **54** can also selectively couple/decouple the coupled port to/from the forward coupled output. Any combination of features of the first switch network **50** described with reference to the isolated

port of the RF coupler **20a** can be implemented by the second switch network **54** in connection with the coupled port of the RF coupler **20a**.

The impedance select switches **65**, **66**, and **67** can be controlled to be in a selected state corresponding to a respective operating mode. In the state shown in FIG. **4**, the impedance select switch **66** electrically connects the termination impedance **76** to the coupled port of the RF coupler **20a** and the other impedance select switches **65** and **67** of the second switch network **54** electrically isolate respective termination impedances **75** and **77** from the coupled port of the RF coupler **20a**. Table 3 below summarizes states of the impedance select switches **65**, **66**, and **67** for various frequency bands according to an embodiment.

TABLE 3

| Reverse Power States | | | |
|----------------------|------|------|------|
| Frequency Band | S 65 | S 66 | S 67 |
| A | On | Off | Off |
| B | Off | On | Off |
| C | Off | Off | On |

The impedance select switches **65**, **66**, and **67** can be controlled so as to provide any suitable combination of termination impedances **75**, **76**, and/or **77** to the coupled port of the RF coupler **20a**. For example, the impedance select switches **65**, **66**, and **67** can be configured into any combination or subcombination of the states shown in Table 4 below. Moreover, the principles and advantages discussed herein can be applied to any suitable number of impedance select switches and corresponding termination impedances.

TABLE 4

| Reverse Power States | | | |
|----------------------|------|------|------|
| Frequency Band | S 65 | S 66 | S 67 |
| A | On | Off | Off |
| B | Off | On | Off |
| C | Off | Off | On |
| D | On | On | Off |
| E | On | Off | On |
| F | Off | On | On |
| G | On | On | On |

Any combination of features of the first termination impedance elements **52** described in connection with the isolated port can be implemented by the second termination impedance elements **56** in connection to the coupled port. In some embodiments, the second termination impedance elements **56** include different termination impedances than the first termination impedance elements **52**. According to some other embodiments, the second termination impedance elements **56** include substantially the same termination impedances as the first termination impedance elements **52**. In certain embodiments, such as the embodiment of FIG. **19A** discussed below, one or more termination impedances can be electrically coupleable to the isolated port and also electrically coupleable to the coupled port.

As illustrated in FIG. **4**, an impedance select switch **66** electrically connects a termination impedance **76** to the coupled port of the RF coupler **20a**. This can set a desired directivity for providing an indication of reverse power for a particular frequency band. As also illustrated in FIG. **4**, a mode select switch **68** of the second switch network **54** can electrically isolate the coupled port from the forward

coupled output and the mode select switch **64** of the first switch network **50** can electrically connect the isolated port to the reverse coupled output. The control circuit **58** can change states of the switches in the first switch network **50** and the second switch network **54** to adjust the state of the electronic system from the state shown in FIG. **3A** to the state shown in FIG. **4**.

FIG. **5** is a schematic diagram illustrating the electronic system of **3A** configured in a different state than in FIG. **3A**. In FIG. **5**, the coupled line of the RF coupler **20a** is decoupled from the main line of the RF coupler **20a**. Instead of providing an indication of forward power at a forward coupled output as shown in FIG. **3A** or providing an indication of reverse power at a reverse coupled output as shown in FIG. **4**, the electronic system can be configured in a decoupled state as shown in FIG. **5**. The decoupled state is a low insertion loss mode. In the decoupled state, the coupled line of the RF coupler **20a** is decoupled from the main line of the RF coupler **20a** in FIG. **5**. Accordingly, coupling loss from the RF coupler **20a** can be significantly reduced or eliminated in the decoupled state. The insertion loss from the main line of the RF coupler **20a** should still be present, however.

The coupled port and the isolated port of the RF coupler can both be electrically isolated from termination impedance elements in the decoupled state. As illustrated in FIG. **5**, the impedance select switches **61**, **62**, **63** of the first switch network **50** can decouple the isolated port from the first termination impedance elements **52** and the impedance select switches **65**, **66**, **67** of the second switch network **54** can decouple the coupled port from the second termination impedance elements **56** in the decoupled state. As also illustrated in FIG. **5**, the mode select switch **64** in the first switch network **50** can decouple the isolated port from the reverse coupled output and the mode select switch **68** of the second switch network **54** can decouple the coupled port from the forward coupled output in the decoupled state. The control circuit **58** can change states of the switches in the first switch network **50** and the second switch network **54** to decouple the coupled line from the main line in the decoupled state shown in FIG. **5**.

FIGS. **6A** and **6B** are schematic diagrams of example termination impedance elements that can implement the functionality of the first termination impedance elements **52** and/or the second termination impedance elements **56** of FIGS. **3A**, **4**, and **5**. A termination impedance can provide an impedance matching function in the RF coupler to increase power transfer and reduce signal reflection. The termination impedance can be provided between a port of the RF coupler, such as one of a coupled port or an isolated port, and a reference potential, such as ground. The termination impedance can be implemented by any suitable passive impedance element or any suitable series and/or parallel combination of passive impedance elements.

As shown in FIG. **6A**, termination impedance elements can be implemented by an adjustable resistance circuit, an adjustable capacitance circuit, and an adjustable inductance circuit. Switches of a switch network can selectively electrically couple these elements to the coupled terminal and/or the isolated terminal of an RF coupler. Adjusting the impedance of one or more of the adjustable resistance circuit, the adjustable capacitance circuit, or the adjustable inductance circuit can achieve a desired directivity of an RF coupler. In some other embodiments, one or two of the adjustable resistance circuit, the adjustable capacitance circuit, or the adjustable inductance circuit can be implemented instead of all three.

FIG. 6B is a schematic diagram illustrating that the first termination impedance elements 52 and/or the second termination impedance elements 56 of FIGS. 3A, 4, and 5 can include a plurality of resistors that are electrically coupled to switches of a switch network. Each of the resistors can have a resistance selected to optimize a directivity of an RF coupler for a particular frequency band. Alternatively or additionally, a combination of resistances of these resistors can optimize directivity of an RF coupler for a particular frequency band.

As discussed above, traditional RF couplers have had a varied coupling factor due to a frequency dependency of the coupled line/main line (e.g., transmission line or inductor) of the RF coupler. To adjust coupling factor of an RF coupler over frequency to compensate for the frequency dependency of the coupled line/main line, an RF coupler with a multi-section coupled line is disclosed herein. Such an RF coupler can provide an adjustable coupling factor that can be adjusted as desired. For instance, such an RF coupler can implement a relatively flat coupling factor over frequency.

Referring to FIGS. 7A to 10C, different states of an electronic system including an RF coupler 20b having a multi-section coupled line according to an embodiment and associated graphs will be described. The RF coupler 20b is another example implementation of the RF coupler 20 of FIGS. 1 and/or 2. A control circuit, similar to the control circuit 58 of FIGS. 3A, 4, and 5, can control the RF coupler 20b and a switch network to bring the electronic system into the states illustrated in FIG. 7A, 8A, 9A, or 10A.

FIG. 7A is a schematic diagram of an RF coupler 20b having a coupled line with an adjustable length electrically connected to a coupled port according to an embodiment. The RF coupler 20b can be implemented in the electronic systems of FIG. 1 and/or FIG. 2, for example. The electronic system of FIG. 7A includes the RF coupler 20b, a switch network including switches 92 to 99, and a termination impedance circuit including termination impedances 104 to 109. In one embodiment, each of the termination impedances 104 to 109 can be implemented by a terminating resistor.

As illustrated in FIG. 7A, the RF coupler 20b has a multi-section main line and a multi-section coupled line. Sections of the main line and the coupled line can be implemented by conductive lines (e.g., microstrips, strip lines, coplanar lines, etc.) and/or inductors. As illustrated, the main line includes sections 80, 82, and 84 and the coupled line includes sections 85, 87, and 89. Although the embodiment of FIG. 7A with a three section coupled line is described for illustrative purposes, the principles and advantages discussed herein can be applied to a two section coupled line and/or to a coupled line with more than three sections. The RF coupler 20b shown in FIG. 7A also includes coupling factor switches 90 and 91 disposed between sections of the coupled line.

The coupling factor of the RF coupler 20b can be adjusted by adjusting the number of sections of the coupled line that are electrically connected to a port of the RF coupler 20b that provides an indication of RF power of a signal traveling between the power input port and the power output port of the RF coupler 20b. For example, the coupling factor can be adjusted by electrically connecting a different number of sections 85, 87, 89 of the multi-section coupled line to the coupled port. This can adjust the length of the coupled line electrically connected to the coupled port. Accordingly, the RF coupler 20b can provide multiple coupling factors for forward power measurements depending on how many sections 85, 87, 89 of the coupled line are electrically

connected to the coupled port. With a longer length of the coupled line electrically connected between a port of the RF coupler 20b and a termination impedance, a higher coupling factor and higher insertion loss can be provided.

With the multi-section RF coupler 20b, the coupling factor can be controlled so as to achieve a relatively flat coupling factor over frequency. The RF coupler 20b can avoid over coupling and thereby prevent excess insertion loss on the main line. Preventing excess insertion loss can be particularly advantageous at relatively higher frequencies when coupling effects can be higher than desired, which can result in a relatively high insertion loss.

The coupling factor switches 90 and 91 can adjust the length of the coupled line between a termination impedance and a port of the RF coupler 20b configured to provide an indication of power traveling between a power input port and a power output port. An effective length of the coupled line electrically connected to the coupled port of the RF coupler 20b can be a length of the coupled line that contributes to the coupling factor of the RF coupler 20b. For instance, the effective length of the coupled line between the termination impedance and the coupled port of the RF coupler 20b can be the length of the section(s) of the coupled line that are electrically connected to the coupled port of the RF coupler 20b. A first coupling factor switch 90 is disposed between a first section 85 and a second section 87 of the coupled line in FIG. 7A. When the first coupling factor switch 90 is on, both the first section 85 and the second section 87 are electrically connected to the coupled port of the RF coupler 20b. When the first coupling factor switch 90 is off, the first coupling factor switch 90 provides electrical isolation between the first section 85 and the second section 87. A second coupling factor switch 91 is disposed between the second section 87 and a third section 89 of the coupled line in FIG. 7A. When the second coupling factor switch 91 is on, the second section 87 and the third section 89 are electrically connected to each other. When the second coupling factor switch 91 is off, the second coupling factor switch 91 provides electrical isolation between the second section 87 and the third section 89.

In the state illustrated in FIG. 7A, the first coupling factor switch 90 and the second coupling factor switch 91 are both on. In this state, the sections 85, 87, and 89 are all electrically connected to the coupled port of the RF coupler 20b. When all sections of the coupled line are electrically connected to the coupled port, the RF coupler 20b can provide a higher coupling effect and a higher insertion loss than when fewer than all of the sections of the coupled line are electrically coupled to the coupled port.

A termination impedance switch is electrically connected to each section of the coupled line in FIG. 7A. The termination impedance switch can selectively electrically connect a respective section of the coupled line to a corresponding termination impedance. The termination impedance switch electrically connected to the section of the coupled line farthest away from and electrically connected to a port of the RF coupler 20b configured to provide an indication of power can be turned on. As illustrated in FIG. 7A, a termination impedance switch 96 is turned on to electrically connect termination impedance 106 to the coupled line.

A first mode select switch 92 can selectively electrically couple the coupled port of the RF coupler 20b to the forward coupled output. In the state shown in FIG. 7A, the mode select switch 92 is on and the coupled port is electrically connected to the forward coupled output. A second mode select switch 93 can selectively electrically couple an isolated port of the RF coupler 20b to the reverse coupled

output. In the state shown in FIG. 7A, the mode select switch 93 is off and the isolated port is electrically isolated from the reverse coupled output.

FIG. 7B is a graph illustrating an insertion loss curve for the radio frequency coupler 20b in the state shown in FIG. 7A. FIG. 7C is a graph illustrating a coupling factor curve for the radio frequency coupler 20b in the state shown in FIG. 7A.

FIG. 8A is a schematic diagram of the system of FIG. 7A in which the radio frequency coupler 20b is configured in a second state. In the second state, two of three sections of the coupled line are electrically connected to the coupled port. The second state provides a lower coupling factor and a lower insertion loss than the first state. In the second state, the second coupling factor switch 91 is opened and the third section 89 is electrically isolated from the coupled port of the RF coupler 20b. This reduces the effective length of the coupled line that contributes to coupling with the main line relative to the first state shown in FIG. 7A. A different termination impedance switch is turned on in the second state shown in FIG. 8A relative to the first state shown in FIG. 7A. As illustrated in FIG. 8A, the termination impedance switch 95 is turned on and electrically connects the termination impedance 105 to the second section 87 of the coupled line.

FIG. 8B is a graph illustrating an insertion loss curve for the radio frequency coupler 20b in the state shown in FIG. 8A. FIG. 8C is a graph illustrating a coupling factor curve for the radio frequency coupler 20b in the state shown in FIG. 8A. These graphs show that insertion loss and coupling factor are different than for the state shown in FIG. 7A.

FIG. 9A is a schematic diagram of the electronic system of FIG. 7A in which the radio frequency coupler 20b is

configured in a third state. In the third state, one of three sections of the coupled line is electrically connected to the coupled port. The third state provides a lower coupling factor and a lower insertion loss than the first state or the second state. In the third state, the first coupling factor switch 90 and the second coupling factor switch 91 are off and the second section 87 and the third section 89 of the coupled line are electrically isolated from the coupled port of the RF coupler 20b. A different termination impedance switch is turned on in the third state shown in FIG. 9A relative to the first state shown in FIG. 7A and the second state shown in FIG. 8A. As illustrated in FIG. 9A, the termination impedance switch 94 is on and electrically couples the termination impedance 104 to the first section 85 of the coupled line.

FIG. 9B is a graph illustrating an insertion loss curve for the radio frequency coupler in the state shown in FIG. 9A. FIG. 9C is a graph illustrating a coupling factor curve for the radio frequency coupler in the state shown in FIG. 9A. These

graphs show that insertion loss and coupling factor are different than for the states shown in FIG. 7A and FIG. 8A.

FIG. 10A is a schematic diagram of the radio frequency coupler 20b of FIG. 7A configured in a fourth state in which the coupled line is decoupled from a main line. In the fourth state, coupling effects and insertion loss due to coupling can be removed from the main line. When the RF coupler 20b is not being used to measure forward RF power or reverse RF power, the system can be configured in the fourth state. The coupled line can be decoupled from the main line when the coupling factor switches 90 and 91 and the termination impedance switches 94, 95, 96, 97, 98, and 99 are off. In addition, the mode select switches 92 and 93 can be off in the fourth state.

FIG. 10B is a graph illustrating an insertion loss curve for the radio frequency coupler 20b in the state shown in FIG. 10A. FIG. 10C is a graph illustrating a coupling factor curve for the radio frequency coupler 20b in the state shown in FIG. 10A. These graphs show that there is reduced insertion loss and coupling factor in the fourth state relative to the first, second, and third states.

The electronic system shown in FIGS. 7A, 8A, 9A, and 10A can be configured in states for providing an indication of reflected power. Accordingly, the RF coupler 20b can be bi-directional. Any suitable control circuit, such as a decoder, can turn switches on and/or off to implement such states. Table 5 below summarizes which of the illustrated switches are on and which of the illustrated switches are off in various states according to an embodiment. Table 6 below provides a brief description of these states. In some embodiments, additional states and/or a subcombination of these states can be implemented.

TABLE 5

| States of Switches for States of 3-Section Coupler of FIG. 7A, 8A, 9A, 10A | | | | | | | | | | |
|---|------|------|------|------|------|------|------|------|------|------|
| State | S 90 | S 91 | S 92 | S 93 | S 94 | S 95 | S 96 | S 97 | S 98 | S 99 |
| 1 | On | On | On | Off | Off | Off | On | Off | Off | Off |
| 2 | On | Off | On | Off | Off | On | Off | Off | Off | Off |
| 3 | Off | Off | On | Off | On | Off | Off | Off | Off | Off |
| 4 | Off | Off | Off | Off | Off | Off | Off | Off | Off | Off |
| 5 | On | On | Off | On | Off | Off | Off | Off | Off | On |
| 6 | Off | On | Off | On | Off | Off | Off | Off | On | Off |
| 7 | Off | Off | Off | On | Off | Off | Off | On | Off | Off |

TABLE 6

| States and Descriptions for 3-Section Coupler of FIG. 7A, 8A, 9A, 10A | |
|--|---------------------------------------|
| State | Description |
| 1 | Forward Power, High Coupling Factor |
| 2 | Forward Power, Medium Coupling Factor |
| 3 | Forward Power, Low Coupling Factor |
| 4 | Decoupled |
| 5 | Reverse Power, High Coupling Factor |
| 6 | Reverse Power, Medium Coupling Factor |
| 7 | Reverse Power, Low Coupling Factor |

The multi-section coupler illustrated in FIGS. 7A, 8A, 9A, and 10A can adjust a coupling factor of the RF coupler (e.g., flatten coupling factor over frequency bands). This can improve insertion loss in certain states.

FIG. 11A is graph with a curve of insertion loss over frequency for a single section coupler. FIG. 11B is a graph with curves of insertion loss over frequency for a multiple

section coupler. FIG. 12A is graph with a curve of coupling factor over frequency for a single section coupler. FIG. 12B is a graph with curves of coupling factor over frequency for a multiple section coupler. Among other things, these graphs illustrate that coupling effects increase as frequency increases in a typical RF coupler, a multi-section RF coupler can effectively compensate for increased coupling effect, and insertion loss improves with reduced coupling effects.

decoupled from the main line. Any suitable control circuit, such as a decoder, can turn switches on and/or off to implement such states. Table 7 below summarizes which of the illustrated switches are on and which of the illustrated switches are off in various states according to an embodiment. Table 8 below provides a brief description of these states. In some embodiments, additional states and/or a subcombination of these states can be implemented.

TABLE 7

| States of Switches for States of 3-Section Coupler of FIG. 13A | | | | | | | | | | | | | | | | |
|--|-----|-----|-----|-----|-----|-----|-----|-----|-----|-----|-----|-----|-----|-----|-----|-----|
| St | 90 | 91 | 92 | 93 | 94a | 94b | 95a | 95b | 96a | 96b | 97a | 97b | 98a | 98b | 99a | 99b |
| 1 | On | On | On | Off | Off | Off | Off | Off | On | Off | Off | Off | Off | Off | Off | Off |
| 2 | On | On | On | Off | Off | Off | Off | Off | Off | On | Off | Off | Off | Off | Off | Off |
| 3 | On | On | On | Off | Off | Off | Off | Off | On | On | Off | Off | Off | Off | Off | Off |
| 4 | On | Off | On | Off | Off | Off | On | Off | Off | Off | Off | Off | Off | Off | Off | Off |
| 5 | On | Off | On | Off | Off | Off | Off | On | Off | Off | Off | Off | Off | Off | Off | Off |
| 6 | On | Off | On | Off | Off | Off | On | On | Off | Off | Off | Off | Off | Off | Off | Off |
| 7 | Off | Off | On | Off | Off | Off | Off | Off | Off | Off | Off | Off | Off | Off | Off | Off |
| 8 | Off | Off | On | Off | On | Off | Off | Off | Off | Off | Off | Off | Off | Off | Off | Off |
| 9 | Off | Off | On | Off | On | On | Off | Off | Off | Off | Off | Off | Off | Off | Off | Off |
| 10 | Off | Off | Off | Off | Off | On | Off | Off | Off | Off | Off | Off | Off | Off | Off | Off |
| 11 | On | On | Off | On | Off | Off | Off | Off | Off | Off | Off | Off | Off | Off | On | Off |
| 12 | On | On | Off | On | Off | Off | Off | Off | Off | Off | Off | Off | Off | Off | Off | On |
| 13 | On | On | Off | On | Off | Off | Off | Off | Off | Off | Off | Off | Off | Off | On | On |
| 14 | On | Off | Off | On | Off | Off | Off | Off | Off | Off | Off | Off | On | Off | Off | Off |
| 15 | On | Off | Off | On | Off | Off | Off | Off | Off | Off | Off | Off | Off | On | Off | Off |
| 16 | On | Off | Off | On | Off | Off | Off | Off | Off | Off | Off | Off | On | On | Off | Off |
| 17 | Off | Off | Off | On | Off | Off | Off | Off | Off | Off | On | Off | Off | Off | Off | Off |
| 18 | Off | Off | Off | On | Off | Off | Off | Off | Off | Off | Off | On | Off | Off | Off | Off |
| 19 | Off | Off | Off | On | Off | Off | Off | Off | Off | Off | On | On | Off | Off | Off | Off |

To implement a relatively flat coupling factor over frequency, a multi-section coupler can be configured such that points along the 3 curves illustrated in FIG. 12B that align for a coupling factor value can be implemented for corresponding frequencies for 3 different frequencies of interest.

FIG. 13A is a schematic diagram of an electronic system that includes multi-section radio frequency coupler 20b having a plurality of termination impedances coupleable to each section, according to an embodiment. The electronic system of FIG. 13A is like the electronic system illustrated in FIGS. 7A, 8A, 9A, and 10A, except that multiple termination impedances are coupleable to each of the sections of the multi-section coupled line. Although an embodiment with a three section coupled line is described in connection with FIG. 13A for illustrative purposes, the principles and advantages discussed herein can be applied to a two section coupled line and/or to a coupled line with more than three sections.

As shown in FIG. 13A, multiple impedance select switches of the switch network are electrically connected to each section of the coupled line. Each of these impedance select switches has a corresponding termination impedance electrically connected thereto. A selected termination impedance can be provided to a respective section of the coupled line. This can achieve a desired directivity. For instance, for a particular frequency band and/or a particular power mode, a selected termination impedance can be provided to a section of the coupled line.

The electronic system illustrated in FIG. 13A can be configured in various states. In some states, the electronic system can be configured for providing an indication of forward power. According to some other states, the electronic system can be configured for providing an indication of reflected power. The electronic system can also be configured in a decoupled state in which the coupled line is

TABLE 8

| States and Descriptions for 3-Section Coupler of FIG. 13A | |
|---|---|
| State | Description |
| 1 | Forward Power, High Coupling Factor, Frequency A ₁ |
| 2 | Forward Power, High Coupling Factor, Frequency B ₁ |
| 3 | Forward Power, High Coupling Factor, Frequency C ₁ |
| 4 | Forward Power, Medium Coupling Factor, Frequency A ₂ |
| 5 | Forward Power, Medium Coupling Factor, Frequency B ₂ |
| 6 | Forward Power, Medium Coupling Factor, Frequency C ₂ |
| 7 | Forward Power, Low Coupling Factor, Frequency A ₃ |
| 8 | Forward Power, Low Coupling Factor, Frequency B ₃ |
| 9 | Forward Power, Low Coupling Factor, Frequency C ₃ |
| 10 | Decoupled |
| 11 | Reverse Power, High Coupling Factor, Frequency A ₄ |
| 12 | Reverse Power, High Coupling Factor, Frequency B ₄ |
| 13 | Reverse Power, High Coupling Factor, Frequency C ₄ |
| 14 | Reverse Power, Medium Coupling Factor, Frequency A ₅ |
| 15 | Reverse Power, Medium Coupling Factor, Frequency B ₅ |
| 16 | Reverse Power, Medium Coupling Factor, Frequency C ₅ |
| 17 | Reverse Power, Low Coupling Factor, Frequency A ₆ |
| 18 | Reverse Power, Low Coupling Factor, Frequency B ₆ |
| 19 | Reverse Power, Low Coupling Factor, Frequency C ₆ |

FIG. 13B is a graph illustrating curves for states of the radio frequency coupler in FIG. 13A with termination impedances. The electronic system of FIG. 13A can be optimized for different frequencies by electrically connecting different termination impedance to a section of the multi-section coupled line. For instance, the bottom two curves in FIG. 13B correspond to the termination impedances 106a and 106b, respectively, being electrically connected to the multi-section coupled line. One termination impedance is optimized for a frequency band around 900 MHz and the other termination impedance is optimized for a frequency band around 2.5 GHz. The top curves in FIG. 13B, which substantially overlap each other, correspond to a signal at the coupled port.

FIG. 13C is a schematic diagram of a radio frequency coupler with a multi-section coupled line having a plurality of termination impedances coupleable to each section, according to another embodiment. As illustrated in FIG. 13C, the main line of the RF coupler can be implemented by a single continuous conductive line 112. The electronic system of FIG. 13C can implement any suitable combination of features discussed with reference to FIGS. 13A and 13B. The conductive line 112 can be a continuous conductive structure extending from the power input port of the RF coupler to the power output port of the RF coupler. The conductive line 112 can be implemented by, for example, a microstrip, a strip line, inductor, or the like. The conductive line 112 can be implemented in place of a multi-section main line in any of the disclosed embodiments that include a multi-section main line.

FIG. 14 is a schematic diagram of a radio frequency coupler having cascaded sections in a coupled line, according to an embodiment. The RF coupler illustrated in FIG. 14 has a two section coupled line. As illustrated, sections of the main line of the RF coupler can be implemented by transmission lines in multiple stacked layers. In FIG. 14, sections of the coupled line can also be implemented by transmission lines in multiple stacked layers 80 and 82. Coupling factor switch 90 can have a first end electrically connected to the first section 85 of the coupled line and a second end electrically connected to the second section 87 of the coupled line. The coupling factor switch 90 can be implemented in an active layer. Termination impedance switches can selectively electrically connect respective termination impedances to a section of the coupled line in accordance with the principles and advantages discussed herein. Any of the principles and advantages of FIG. 14 can be implemented in combination with any of the disclosed embodiments as appropriate.

FIG. 15 is a schematic diagram of a radio frequency coupler having multiple layers in which multiple coupled line sections can share the same main coupler line, according to an embodiment. The RF coupler illustrated in FIG. 15 includes a coupled line with two sections. As illustrated, sections 85 and 87 are disposed adjacent to a common section 115 of the main line. In FIG. 15, sections 85 and 87 of the coupled line can be implemented by transmission lines in multiple stacked layers. The coupling factor switch 90 can be implemented in an active layer. Any of the principles and advantages of FIG. 15 can be implemented in combination with any of the disclosed embodiments as appropriate.

FIG. 16A is a schematic diagram of a radio frequency coupler, a termination impedance circuit configured to provide an adjustable termination impedance, and an isolation switch coupled between the radio frequency coupler and the termination impedance circuit, according to an embodiment. The RF coupler 20a can be implemented in the electronic systems of FIG. 1 and/or FIG. 2, for example. The electronic system of FIG. 16A includes an RF coupler 20a, isolation switches 120 and 122, a memory 125, a control circuit 58', termination impedance circuits 130 and 140, and mode select switches 64 and 68. The RF coupler 20a illustrated in FIG. 16A is a bi-directional coupler. The electronic system of FIG. 16A can include more elements than illustrated and/or a subcombination of the illustrated elements can be implemented. Moreover, the electronic system of FIG. 16A can be implemented in accordance with any suitable combination of the principles and advantages discussed herein.

The termination impedance circuits 130 and 140 of FIG. 16A are tunable to provide a desired termination impedance

to a port of the RF coupler 20a. Termination impedance circuit 130 can be tuned to provide a desired termination impedance to the isolated port of the RF coupler 20a. The termination impedance circuit 130 can tune resistance, capacitance, and/or inductance provided to the isolated port of the RF coupler 20a. Such tunability can be advantages for post-design configuration and/or compensation and/or optimization.

The termination impedance circuit 130 can tune the termination impedance provided to the isolated port by providing series and/or parallel combinations of passive impedance elements. As illustrated in FIG. 16A, the termination impedance circuit 130 includes switches 131 to 139 and passive impedance elements R2a to R2n, L2a to L2n, and C2a to C2n. Each of the switches 131 to 139 can selectively switch in a respective passive impedance element to the termination impedance provided to the isolated port. In the termination impedance circuit 130 illustrated in FIG. 16A, at least three switches should be on in order to provide a termination path between a connection node n1 and ground.

The switches of the termination impedance circuit 130 illustrated in FIG. 16A include three banks of parallel switches 131 to 133, 134 to 136, and 137-139 in series with each other. A first bank of switches 131 to 133 is coupled between connection node n1 and a first intermediate node n2. The second bank of switches 134 to 136 is coupled between the first intermediate node n2 and a second intermediate node n3. The third bank of switches 137 to 139 is coupled between the second intermediate node n3 and a reference potential, such as ground. Having banks of switches in parallel with other banks of parallel switches can increase the number of possible termination impedance values provided by the termination impedance circuit 130. For example, when the termination impedance circuit 130 includes 3 banks of 3 parallel switches in series with each other, the termination impedance circuit can provide 343 different termination impedance values by having one or more of the switches in each bank of switches on while the other switches are off.

The illustrated termination impedance circuit 130 includes series circuits that include a passive impedance element and a switch in parallel with other series circuits that include other passive impedance elements and other switches. For instance, a first series circuit that includes the switch 131 and the resistor R2a is in parallel with a second series circuit that includes switch 132 and the resistor R2b. The termination impedance circuit 130 includes switches 134 to 136 to switch inductors L2a to L2n, respectively, in series with one or more resistors R2a to R2n. The switches 134 to 136 can also switch two or more of the inductors L2a to L2n in parallel with each other. The termination impedance circuit 130 also includes switches 137 to 139 to switch capacitors C2a to C2n, respectively, in series with one or more resistor-inductor (RL) circuits. The switches 137 to 139 can also switch two or more of the capacitors C2a to C2n in parallel with each other.

As illustrated in FIG. 16A, the switches 132, 136, 137, and 138 can be on while the other switches in the termination impedance circuit 130 are off. This can provide a termination impedance to the isolated port of the RF coupler 20a that includes the resistor R2b in series with inductor L2n in series with the parallel combination of capacitors C2a and C2b.

The termination impedance circuit 130 can include passive impedance elements having arbitrary values, binary weighted values, values to compensate for variations, values

for a particular application, the like, or any combination thereof. While the termination impedance circuit 130 can provide RLC circuits, the principles and advantages discussed herein can be applied to a termination impedance circuit that can provide any suitable combination of circuit elements such as one or more resistors, one or more inductors, one or more capacitors, one or more RL circuits, one or more RC circuits, one or more LC circuits, or one or more RLC circuits to provide a desired termination impedance. Such combinations of circuit elements can be arranged in any suitable series and/or parallel combination.

The switches 131 to 139 can be implemented by field effect transistors. Alternatively, or additionally, one or more switches of the termination impedance circuit 130 can be implemented by MEMS switches, fuse elements (e.g., fuses or antifuses), or any other suitable switch element.

While the termination impedance circuit 130 illustrated in FIG. 16A includes switches, a tunable termination impedance can alternatively or additionally be provided by other variable impedance circuits. For instance, the termination impedance circuit can implement a tunable termination impedance using an impedance element having an impedance that varies as a function of a signal provided to impedance element. As one example, a field effect transistor operating in the linear mode of operation can provide an impedance dependent on a voltage provided to its gate. As another example, a varactor diode can provide a variable capacitance as a function of voltage provided to the varactor diode.

The illustrated termination impedance circuit 140 can function substantially the same as the illustrated termination impedance circuit 130 except that the termination impedance circuit 140 can provide a termination impedance to the coupled port instead of the isolated port. The impedances of the passive impedance elements of the termination impedance circuit 130 can be substantially the same as corresponding passive impedance elements of the termination impedance circuit 140. One or more of the passive impedance elements of the termination impedance circuit 130 can have a different impedance value than a corresponding passive impedance element of the termination impedance circuit 140. In certain embodiments (not illustrated), the termination impedance circuit 130 and the termination impedance circuit 140 can have circuit topologies that are different from each other.

The illustrated isolation switches 120 and 122 can serve to provide isolation between ports of the RF coupler 20a and the termination impedance circuits 130 and 140, respectively. Each of the isolation switches 120 and 122 can selectively electrically connect a port of the RF coupler 20a to a termination impedance circuit 130 or 140, respectively, responsive to a control signal received at a control termination of the respective isolation switch. As illustrated, the isolation switch 122 is electrically connected between the coupled port of the RF coupler 20a and the termination impedance circuit 140. The isolation switch 122 can be off when the coupled port is providing indication of forward RF power as illustrated in FIG. 16A. When isolation switch 122 is off, the isolation switch 122 can separate the loading of the termination impedance circuit 140 from the coupled port. In particular, the isolation switch 122 can isolate switches 141 to 143 of the first bank of switches of the termination impedance circuit 140 from the coupled port when the isolation switch 122 is off. This can improve insertion loss by removing loading of switch bank switches on the coupled port of the RF coupler 20a. With the isolation switch 122, there are two switches in series between any passive imped-

ance element of the termination impedance circuit 140 and the coupled port of the RF coupler 20a in the illustrated embodiment.

When the electronic system of FIG. 16A is in another state (not illustrated) where the isolated port is providing an indication of reverse RF power, the isolation switch 122 can be on to electrically connect the termination impedance circuit 140 to the coupled port.

The isolation switch 122 can be implemented by a field effect transistor, for example. In certain implementations, the isolation switch 122 can be implemented by a switch in series between the connection node n1 and the coupled port of the RF coupler and a shunt switch connected to the connection node n1. According to some implementations, the isolation switch 122 can be implemented by a series-shunt-series switch topology, for example, as illustrated in FIGS. 19B and 19C. The isolation switch 122 can be implemented by a single throw switch. The isolation switch 122 can be implemented by a single pole switch. The isolation switch 122 can be implemented by a single pole, single throw switch as illustrated.

The isolation switch 120 of FIG. 16A is electrically connected between the isolated port of the RF coupler 20a and the termination impedance circuit 130. The isolation switch 120 can be off when the isolated port is providing an indication of reverse RF power (not illustrated) and on when the coupled port is providing an indication of forward RF power as illustrated. Aside from the different connections and different timing when the switches are activated and deactivated, the isolation switches 120 and 122 can be substantially the same. Both of the isolation switches 120 and 122 can be off in a decoupled state. The isolation switches 120 and 122 can implement a switch circuit that can selectively electrically couple the termination impedance circuit 130 to the isolated port and that can selectively electrically couple the termination impedance circuit 140 to the coupled port.

The memory 125 can store data to set the state of one or more switches in the termination impedance circuit 130 and/or the termination impedance circuit 140. The memory 125 can be implemented by persistent memory elements, such as fuse elements. In some other implementations, the memory 125 can include volatile memory elements. The memory 125 can store data indicative of process variations. Alternatively or additionally, the memory 125 can store data indicative of application parameters. The memory 125 can be embodied on same die as control circuit 58' and/or termination impedance circuits 130 and 140. The memory 125 can be included in the same package as the RF coupler 20a.

The illustrated control circuit 58' is in communication with the memory 125. The control circuit 58' is configured to provide one or more control signals to set the state of the one or more switches of the termination impedance circuits 130 and 140 based at least partly on the data stored in the memory 125. The control circuit 58' can implement any combination of features of the control circuit 58 discussed herein. The control circuit 58' can be a decoder, for example.

The memory 125 and the control circuit 58' can together configure the termination impedance circuits 130 and/or 140 after the electronic system of FIG. 16A has been manufactured. This can configure a termination impedance provided to the RF coupler 20a to compensate for process variations. For instance, the memory 125 can include fuse elements and the control circuit 58' can include a decoder. In this example, after a process variation has been detected, a fuse element of the memory 125 can be blown and this can cause the control

circuit **58'** to set one or more switches of the termination impedance circuits **130** and/or **140** to the on position such that a particular passive impedance element is included in the termination path provided to a port of the RF coupler **20a** to compensate for the process variation. As another example, a termination impedance provided to the RF coupler **20a** can be configured to a particular application parameter, such as operating in a particular frequency band.

FIG. **16B** is a graph illustrating a coupling signal at a coupled port and signals at an isolated port optimized for two different frequencies for the radio frequency coupler illustrated in FIG. **16A**. FIG. **16B** shows that termination impedance can be optimized for a particular frequency using the termination impedance circuit **130** and/or the termination impedance circuit **140**. Termination impedance can be adjusted for other parameters as desired.

FIG. **17A** is a schematic diagram of a radio frequency coupler, a termination impedance circuit configured to provide an adjustable termination impedance, and an isolation switch between the radio frequency coupler and the termination impedance circuit, according to another embodiment. The electronic system of FIG. **17A** can include more elements than illustrated and/or a subcombination of the illustrated elements can be implemented. Moreover, the electronic system of FIG. **17A** can be implemented in accordance with any suitable combination of the principles and advantages discussed herein.

The electronic system of FIG. **17A** includes different termination impedance circuits than FIG. **16A**. The termination impedance circuits **130'** and **140'** of FIG. **17A** can adjust termination impedance provided to the isolated port and the coupled port, respectively, of the RF coupler **20a**, with different circuit topologies than the termination impedance circuits **130** and **140** of FIG. **16A**. For example, the termination impedance circuit **130'** illustrated in FIG. **17A** includes switches **155** and **156** that can selectively provide an electrical connection between RLC circuits and a port of the RF coupler. The illustrated termination impedance circuit **130'** can also provide an RC termination (e.g., when switches **152** and/or **153** are on and switches **157** and/or **158** are on) or an LC termination (e.g., when switch **154** is on and switches **157** and/or **158** are on) to the isolated port of the RF coupler **20a**. In the illustrated termination impedance circuit **130'**, different passive impedance elements that are ratioed to each other (e.g., capacitors $0.1C$ and $0.2C$; resistors $0.1R$, $0.2R$, and $0.4R$; or ratioed inductors [not illustrated in FIG. **17A**]) can be selectively switched in individually or in parallel with each other. Such impedance elements can be used to compensate for process variations or to configure an electronic system for certain applications. For instance, data indicative of a process variation can be stored in the memory **125** and the control circuit **58'** can set the state of a switch to switch in or switch out a particular impedance to thereby compensate for a process variation.

The illustrated termination impedance circuit **140'** can function substantially the same as the illustrated termination impedance circuit **130'** except that the termination impedance circuit **140'** can provide a termination impedance to the coupled port instead of the isolated port. The impedances of the passive impedance elements of the termination impedance circuits **130'** and **140'** can be substantially the same or one or more of the passive impedance values can have a different impedance value. In certain embodiments (not illustrated), the termination impedance circuit **130'** and the termination impedance circuit **140'** can have different circuit topologies.

FIG. **17B** is a graph illustrating a coupling signal at a coupled port and signals at an isolated port optimized for two different frequencies for the radio frequency coupler illustrated in FIG. **17A**. FIG. **17B** shows that termination impedance provided by the termination impedance circuit **130'** can be optimized for particular frequencies. In particular, RLC circuit **RLC2a** can be optimized for a frequency band centered around 900 MHz and RLC circuit **RLC2b** can be optimized for a frequency band centered around 2.5 GHz. Adjusting the state of switches **155** and **156** can provide different termination impedances to the isolated port for these frequency bands. Termination impedance can be adjusted for other parameters as desired.

FIG. **18** is a flow diagram of an illustrative process **170** of setting a state of a switch in a termination impedance circuit, according to an embodiment. The process **170** can be applied in combination with any of the principles and advantages discussed herein with reference to an adjustable termination impedance circuit and/or an RF coupler.

At block **172**, data indicative of a desired termination impedance at a port of a radio frequency (RF) coupler can be obtained. The obtained data can be indicative of a process variation, temperature dependence, and/or an application parameter, for example. The port of the RF coupler can be an isolated port or a coupled port.

The data can be stored to physical memory at block **174**. This can make the stored data are accessible to at least partly configure a termination impedance circuit electrically connected to the port of the RF coupler based at least partly on the data stored to the memory. For instance, the data can be accessible to set a state of one or more switches of the termination impedance circuit. As another example, the data can be accessible to configure a variable impedance element at a selected impedance value. As yet another example, the data can be accessible to blow a fuse element of a termination impedance circuit. The data can be stored to the memory **125** of FIGS. **16A** and/or **17A**, for example. The memory can be persistent memory, such as a fuse element. In other embodiments, the memory can be volatile memory. The memory can be on the same die as a control circuit and/or the termination impedance circuit in some implementations. The memory can be within the same package as the RF coupler. The one or more switches can include a field effect transistor, a MEMS switch, and/or any other suitable switch element.

At block **176**, the termination impedance circuit can be configured based at least partly on the data stored to the memory. For instance, a state of the one or more switches of termination impedance circuit can be set based at least partly on the data stored to memory at block **174**. The state can be set to an on state or an off state. Setting the state of the switch to an on state can electrically couple a particular passive impedance element to the port of the RF coupler. This can compensate for a process variation, compensate for temperature dependence, configure a termination impedance circuit for a specific application, etc.

FIG. **19A** is a schematic diagram of a radio frequency coupler and a termination impedance circuit coupleable to an isolated port or a coupled port of the radio frequency coupler by way of switches, according to an embodiment. The RF coupler **20a** of FIG. **19A** can be implemented in the electronic systems of FIG. **1** and/or FIG. **2**, for example. The electronic system of FIG. **19A** includes an RF coupler **20a**, isolation switches **180** and **182**, and a shared termination impedance circuit **190**. The RF coupler **20a** illustrated in FIG. **19A** is a bi-directional coupler that can provide an indication of forward RF power or reverse RF power. The

electronic system of FIG. 19A can include more elements than illustrated and/or a subcombination of the illustrated elements can be implemented. Moreover, the electronic system of FIG. 19A can be implemented in accordance with any suitable combination of the principles and advantages discussed herein.

In the electronic system illustrated in FIG. 19A, the shared impedance circuit 190 can be electrically coupled to the isolated port of the RF coupler 20a in a first state and electrically coupled to the coupled port of the RF coupler 20a in a second state. In the first state, the RF coupler 20a can provide an indication of forward RF power to the coupled port. In the second state, the RF coupler 20a can provide an indication of reverse RF power to the isolated port. Having a common termination impedance circuit 190 can reduce physical layout compared to having separate termination impedance circuits for different ports of an RF coupler.

A switch circuit including the isolation switches 180 and 182 can selectively electrically connect different ports of the RF coupler 20a to the shared termination impedance circuit 190 in different states. The isolation switches 180 and 182 can selectively electrically connect the shared termination impedance circuit 190 of FIG. 19A to the coupled port of the RF coupler 20a or the isolated port of the RF coupler 20a. As illustrated, the isolation switches 180 and 182 are both electrically connected to the same node (i.e., connection node n1) of the shared termination impedance circuit 190. In other implementations (not illustrated), switches can selectively electrically couple a termination impedance circuit to any two ports of an RF coupler or selectively electrically couple a termination impedance circuit to any three or more ports of an RF coupler.

The isolation switches 180 and 182 can provide higher isolation in an off state than a desired directivity (e.g., 10 dB or better in certain implementations). This can provide sufficient isolation between the coupled port and the isolated port of the RF coupler 20a to achieve the desired directivity with the shared termination impedance circuit 190. The isolation switches can each include a series-shunt-series circuit topology implemented by field effect transistors, a MEMS switch, or any other suitable switch element to provide sufficient isolation for a desired directivity.

FIGS. 19B and 19C are schematic diagrams of the isolation switches 182 and 180, respectively, of FIG. 19A according to an embodiment. FIG. 19B shows an isolation switch in an off state and FIG. 19C shows an isolation switch in an on state. As shown in FIG. 19B, the isolation switch 182 can include switches 184, 186, and 188 in a series-shunt-series circuit topology. When the switch 182 is in an off state as illustrated in FIG. 19B, the shunt switch 188 can be on to provide a ground potential to a node between series switches 184 and 186 that are both in an off state. As shown in FIG. 19C, the isolation switch 180 can include switches 184', 186', and 188' in a series-shunt-series circuit topology. When the switch 180 is in an on state as illustrated in FIG. 19C, the shunt switch 188' can be off and the series switches 184' and 186' can both be in an on state. The isolation switches 180 and 182 can both be off in a decoupled state.

The shared termination impedance circuit 190 can provide the same or different termination impedance to different ports of the RF coupler 20a. As illustrated, any termination impedance value that can be provided to the isolated port of the RF coupler 20a in a first state can be provided to the coupled port of the RF coupler 20a in a second state. The illustrated shared termination impedance circuit 190 is tunable to provide an adjustable impedance. While the shared

termination impedance circuit 190 illustrated in FIG. 19A has the same circuitry topology as the termination impedance circuits 130' and 140' of FIG. 17A, shared termination impedance circuits can implement any combination of features of the adjustable termination impedance circuits discussed herein such as the termination impedance circuits of FIGS. 3A, 4, 5, 13A, and/or 16A. Moreover, the principles and advantages of sharing a termination impedance circuit discussed with reference to FIG. 19A can be applied to fixed termination impedance (e.g., fixed termination resistor).

RF couplers with multi-section coupled lines can be implemented in connection with any of the adjustable termination impedance circuits discussed herein. A switch network can selectively electrically connect an adjustable termination impedance circuit to a selected section of a multi-section coupled line. With such a switch network, one adjustable termination impedance circuit can be shared among a plurality of sections of the multi-section coupled line. Alternatively or additionally, a switch network can selectively electrically couple separate adjustable termination impedance circuits to different sections of a multi-section coupled line. In some embodiments, a switch network can selectively electrically connect one of a coupled port or an isolated port to a single power output port.

Illustrative embodiments of electronic systems with RF couplers having a multi-section coupled line, a switch network, and one or more adjustable termination impedance circuits will be discussed with reference to FIGS. 20 to 25B. Any suitable combination of features of one switch network of the switch networks of FIGS. 20 to 25A can be implemented in connection with features of one or more of the other switch networks of FIGS. 20 to 25A. Other logically and/or functionally equivalent switch networks can alternatively or additionally be implemented. Any suitable termination impedance circuit discussed herein and/or suitable combination of features of a termination impedance circuit discussed herein can be implemented in connection with any of the embodiments discussed herein, such as any of the embodiments of FIGS. 20 to 25B. Similarly, any of the principles and advantages of the control circuits and/or the memories discussed herein can be implemented in combination with the principles and advantages discussed with reference to FIGS. 20 to 25B.

FIG. 20 is a schematic diagram of an electronic system that includes a radio frequency coupler having a multi-section coupled line, termination impedance circuits 130 and 140, and a switch network 200 configured to selectively electrically connect the termination impedance circuit 130 to a selected section of the multi-section coupled line, according to an embodiment. In FIG. 20, the RF coupler includes a multi-section coupled line that includes sections 85, 87, and 89. Coupling factor switches 90 and 91 can selectively electrically connect sections of the multi-section coupled line to each other, as illustrated. While the RF coupler illustrated in FIG. 20 includes a coupled line having 3 sections, the principles and advantages discussed with FIG. 20 can be applied to two section coupled lines and/or coupled lines having four or more sections. The main line of the RF coupler of FIG. 20 includes a single conductive line 112, like in FIG. 13C.

The electronic system of FIG. 20 includes the termination impedance circuit 130, the termination impedance circuit 140, and the isolation switches 120 and 122, which can each be as described with reference to FIG. 16A. In certain embodiments, the termination impedance circuit 130' of FIG. 17A can be implemented in place of the termination impedance circuit 130 in the electronic system of FIG. 20.

According to some other embodiments, other suitable termination impedance circuits can be implemented in place of the termination impedance circuit **130** in the electronic system of FIG. **20**, such as the termination impedance circuit illustrated in FIG. **25B**. In certain embodiments, the termination impedance circuit **140'** of FIG. **17A** can be implemented in place of the termination impedance circuit **140** in the electronic system of FIG. **20**. According to some other embodiments, other suitable termination impedance circuits can be implemented in place of the termination impedance circuit **140** in the electronic system of FIG. **20**, such as the termination impedance circuit illustrated in FIG. **25B**.

The electronic system of FIG. **20** also includes a control circuit **58''** and a memory **125**. The memory **125** can be as described with reference to FIG. **16A**. The memory can implement any combination of features discussed with reference to FIG. **18**. The control circuit **58''** can implement any combination of features of the control circuits **58** and **58'** discussed herein. The control circuit **58''** can also provide control signals for the switch network **200**.

The switch network **200** can selectively electrically connect the termination impedance circuit **130** to a selected section of the multi-section coupled line. As illustrated, the switch network **200** includes switches **202**, **204**, and **206**. Each of these switches can be turned on and turned off responsive to a respective control signal provided by the control circuit **58''**. As illustrated in FIG. **20**, the switch **204** electrically connects the termination impedance circuit **130** to the second section **87** of the multi-section coupled line.

Table 9 below summarizes which of the illustrated switches are on and which of the illustrated switches are off in various states. FIG. **20** corresponds to state 2, in which the RF coupler is configured to provide an indication of forward power with a medium coupling factor. Table 10 below provides a brief description of these states. In some embodiments, additional states and/or a subcombination of these states can be implemented. Any suitable control circuit **58''**, such as a decoder, can turn switches on and/or off to implement such states. The termination impedance circuit **130** can be configured into any suitable configuration in any of states 1 to 3 in Table 9 below to provide a desired termination impedance. The termination impedance circuit **140** can be configured into any suitable configuration in any of states 5 to 7 in Table 9 below to provide a desired termination impedance.

TABLE 9

| States of Switches for RF Coupler of FIG. 20 | | | | | | | | | |
|--|-----|-----|-----|-----|-----|-----|-----|-----|-----|
| State | 90 | 91 | 92 | 93 | 120 | 122 | 202 | 204 | 206 |
| 1 | Off | Off | On | Off | On | Off | On | Off | Off |
| 2 | On | Off | On | Off | On | Off | Off | On | Off |
| 3 | On | On | On | Off | On | Off | Off | Off | On |
| 4 | Off | Off | Off | Off | Off | Off | Off | Off | Off |
| 5 | Off | Off | Off | On | Off | On | On | Off | Off |
| 6 | On | Off | Off | On | Off | On | Off | On | Off |
| 7 | On | On | Off | On | Off | On | Off | Off | On |

TABLE 10

| States and Descriptions for RF Coupler of FIG. 20 | |
|---|---------------------------------------|
| State | Description |
| 1 | Forward Power, Low Coupling Factor |
| 2 | Forward Power, Medium Coupling Factor |

TABLE 10-continued

| States and Descriptions for RF Coupler of FIG. 20 | |
|---|---------------------------------------|
| State | Description |
| 3 | Forward Power, High Coupling Factor |
| 4 | Decoupled |
| 5 | Reverse Power, Low Coupling Factor |
| 6 | Reverse Power, Medium Coupling Factor |
| 7 | Reverse Power, High Coupling Factor |

FIG. **21** is a schematic diagram of an electronic system that includes a radio frequency coupler having a multi-section coupled line, termination impedance circuits **130** and **140**, and a switch network configured to selectively electrically connect the termination impedance circuit **140** to a selected section of the multi-section coupled line, according to another embodiment. The electronic system of FIG. **21** is similar to the electronic system of FIG. **20** except that the switch network **200** of FIG. **20** is replaced by the switch network **210**.

The illustrated switch network **210** includes switches **212**, **214**, **216**, and **218**. The switch network **210** can selectively electrically connect the termination impedance circuit **140** to a selected section **85**, **87**, or **89** of the multi-section coupled line. The switch network **210** is also configured to electrically decouple each of the sections of the multi-section coupled line from the termination impedance circuits **130** and **140**. For instance, the switch network **210** includes switch **218** that can be turned off to electrically isolate the section **89** from the termination impedance circuit **130**.

FIG. **22A** is a schematic diagram of an electronic system that includes a radio frequency coupler having a multi-section coupled line, termination impedance circuits **130** and **140**, and switches configured to selectively electrically connect a selected termination impedance circuit of the termination impedance circuits to a selected section of the multi-section coupled line, according to another embodiment. The electronic system of FIG. **22A** is similar to the electronic systems of FIGS. **20** and **21** except that the switch network **220** is implemented in place of the switch networks **200/210** and there are additional switches in series between adjacent sections of the multi-section coupled line. Instead of switches **90** and **91** in FIGS. **20** and **21**, switches **90A**, **90B**, **91A**, and **91B** are included in the electronic system of FIG. **22A**.

The illustrated switch network **220** includes switches **221**, **222**, **223**, **224**, **225**, **226**, and **227**. The switch network **220** can selectively electrically connect the termination impedance circuit **130** to a selected section **85**, **87**, or **89** of the multi-section coupled line. The switch network **220** can also selectively electrically connect the termination impedance circuit **140** to a selected section **85**, **87**, or **89** of the multi-section coupled line. The switch network **220** provides more options to selectively electrically connect termination impedance circuits **130** and **140** to a selected section of the multi-section coupled line of the RF coupler relative to the switch networks **200** and **210**. The switch network **200** together with the coupling factor switches **90A**, **90B**, **91A**, and **91B** can also provide additional options for electrically connecting sections of the multi-section coupled line to the coupled port of the RF coupler.

As illustrated in FIG. **22A**, the RF coupler is configured to provide an indication of forward power and the second section **87** of the coupled line is switched in while the first section **85** and the third section **89** are switched out. The switch network **220**, along with other illustrated switches,

electrically connects one end of the second section **87** to the forward coupled output and electrically connects the other end of section **87** to the termination impedance circuit **130** as illustrated in FIG. **22A**.

Table 11 below summarizes which of the illustrated switches are on and which of the illustrated switches are off in various states. FIG. **22A** corresponds to state 2 in this table. Table 12 below provides a brief description of these states. In some embodiments, additional states and/or a subcombination of these states can be implemented. Any suitable control circuit **58"**, such as a decoder, can turn switches on and/or off to implement such states. The termination impedance circuit **130** can be configured into any suitable state in any of states 1 to 7 in Table 11 below to provide a desired termination impedance. The termination impedance circuit **140** can be configured into any suitable state in any of States 9 to 15 in Table 11 below to provide a desired termination impedance.

TABLE 11

| States of Switches for RF Coupler of FIG. 22A | | | | | | | | | | | | | | | |
|---|-----|-----|-----|-----|-----|-----|-----|-----|-----|-----|-----|-----|-----|-----|-----|
| State | 90a | 90b | 91a | 91b | 92 | 93 | 120 | 122 | 221 | 222 | 223 | 224 | 225 | 226 | 227 |
| 1 | On | Off | Off | Off | On | Off | On | Off | On | On | Off | Off | Off | On | On |
| 2 | Off | On | On | Off | On | Off | On | Off | Off | On | On | Off | On | Off | On |
| 3 | Off | Off | Off | On | On | Off | On | Off | Off | Off | On | On | On | On | Off |
| 4 | On | On | On | Off | On | Off | On | Off | On | Off | On | Off | Off | Off | On |
| 5 | On | Off | Off | On | On | Off | On | Off | On | On | On | On | Off | On | Off |
| 6 | Off | On | On | On | On | Off | On | Off | Off | On | Off | On | On | Off | Off |
| 7 | On | On | On | On | On | Off | On | Off | On | Off | Off | On | Off | Off | Off |
| 8 | Off | Off | Off | Off | Off | Off | Off | Off | Off | Off | Off | Off | Off | Off | Off |
| 9 | On | Off | Off | Off | Off | On | Off | On | On | On | Off | Off | Off | On | On |
| 10 | Off | On | On | Off | Off | On | Off | On | Off | On | On | Off | On | Off | On |
| 11 | Off | Off | Off | On | Off | On | Off | On | Off | Off | On | On | On | On | Off |
| 12 | On | On | On | Off | Off | On | Off | On | On | Off | On | Off | Off | Off | On |
| 13 | On | Off | Off | On | Off | On | Off | On | On | On | On | On | Off | On | Off |
| 14 | Off | On | On | On | Off | On | Off | On | Off | On | Off | On | On | Off | Off |
| 15 | On | On | On | On | Off | On | Off | On | On | Off | Off | On | Off | Off | Off |

TABLE 12

| States and Descriptions for RF Coupler of FIG. 22A | |
|--|--|
| State | Description |
| 1 | Forward Power, Section 85 Electrically Connected to Coupled Port |
| 2 | Forward Power, Section 87 Electrically Connected to Coupled Port |
| 3 | Forward Power, Section 89 Electrically Connected to Coupled Port |
| 4 | Forward Power, Sections 85 & 87 Electrically Connected to Coupled Port |
| 5 | Forward Power, Sections 85 & 89 Electrically Connected to Coupled Port |
| 6 | Forward Power, Sections 87 & 89 Electrically Connected to Coupled Port |
| 7 | Forward Power, Sections 85, 87 & 89 Electrically Connected to Coupled Port |
| 8 | Decoupled |
| 9 | Reverse Power, Section 85 Electrically Connected to Coupled Port |
| 10 | Reverse Power, Section 87 Electrically Connected to Coupled Port |
| 11 | Reverse Power, Section 89 Electrically Connected to Coupled Port |
| 12 | Reverse Power, Sections 85 & 87 Electrically Connected to Coupled Port |
| 13 | Reverse Power, Sections 85 & 89 Electrically Connected to Coupled Port |
| 14 | Reverse Power, Sections 87 & 89 Electrically Connected to Coupled Port |
| 15 | Reverse Power, Sections 85, 87 & 89 Electrically Connected to Coupled Port |

FIG. **22B** is a schematic diagram of an electronic system that includes a radio frequency coupler having a multi-section coupled line, termination impedance circuits **130'** and **140'**, and switches configured to selectively electrically

connect a selected termination impedance circuit of the termination impedance circuits to a selected section of the multi-section coupled line, according to another embodiment. The electronic system of FIG. **22B** is similar to the electronic system of FIG. **22A** except that the termination impedance circuits **130'** and **140'** are implemented in place of the termination impedance circuits **130** and **140**. In an embodiment, one termination impedance circuit from FIG. **22A** (e.g., the termination impedance circuit **130**) can be implemented and one termination impedance circuit from FIG. **22B** (e.g., the termination impedance circuit **140'**) can be implemented. Other suitable termination impedance circuits can be implemented in various embodiments.

FIG. **22C** is a schematic diagram of an electronic system that includes a radio frequency coupler having a multi-section coupled line, termination impedance circuits **130** and **140**, and switches configured to selectively electrically connect a termination impedance circuit to a selected section of

the multi-section coupled line, according to another embodiment. The electronic system of FIG. **22C** is similar to the electronic system of FIG. **22A** except that the switch network **220'** is implemented in place of the switch network **220** and there are fewer switches in series between adjacent sections of the multi-section coupled line. In particular, in the electronic system of FIG. **22C**, switches **90**, **91**, **222A**, **222B**, **223A**, and **223B** are implemented instead of switches **90A**, **90B**, **91A**, **91B**, **222**, and **223** of FIG. **22A**. Other suitable switch networks can be implemented in various embodiments.

FIG. **23A** is a schematic diagram of an electronic system that includes a radio frequency coupler having a two section coupled line, termination impedance circuits **130** and **140**, and a switch network **230** configured to selectively electrically connect a selected termination impedance circuit of the termination impedance circuits to a selected section of the multi-section coupled line, according to another embodiment. As illustrated, the switch network **230** includes switches **221**, **222**, **224**, **225**, and **227**. The switch network **230** can switch in section **85**, section **87**, or both sections **85** and **87**. The switch network **230** can selectively electrically connect one of the termination impedance circuits **130** or **140** to either section **85** or section **87**. The switch network **230** can also decouple sections **85** and **87** from both of the termination impedance circuits **130** and **140**. Other suitable termination impedance circuits can be implemented in connection with the switch network **230**. As illustrated in FIG. **23A**, the switch network **230** electrically connects a first end

of the second section **87** to the forward coupled output and electrically connects a second end of the second section **87** to the termination impedance circuit **130**. In the state illustrated in FIG. **23A**, the first section **85** should not significantly contribute to the coupling factor of the illustrated RF coupler. Accordingly, the length of the first section **85** is not considered part of the effective length of the coupled line electrically connected to the coupled port in the state illustrated in FIG. **23A**.

FIG. **23B** is a schematic diagram of an electronic system that includes a radio frequency coupler having a two section coupled line, termination impedance circuits **130** and **140**, and a switch network **230** configured to selectively electrically connect a selected termination impedance circuit of the termination impedance circuits to a selected section of the multi-section coupled line, according to another embodiment. The electronic system of FIG. **23B** is similar to the electronic system of FIG. **23A** except that the electronic system of FIG. **23B** also includes switches **90A** and **90B** in series between sections **85** and **87**.

FIG. **24** is a schematic diagram of an electronic system that includes a radio frequency coupler having a multi-section coupled line, a shared termination impedance circuit **190**, and a switch network **220**, according to another embodiment. The switch network **220** and the isolation switches **180** and **182** are together configured to selectively electrically connect the shared termination impedance circuit **190** to a selected section of the multi-section coupled line. The electronic system illustrated in FIG. **24** is similar to the electronic system illustrated in FIG. **19A** except that the electronic system in FIG. **24** includes a multi-section coupled line and the switch network **220**. As illustrated, the switch network **220** can selectively electrically connect the shared termination impedance circuit **190** to a selected section of the multi-section coupled line. The switch network **220** can selectively electrically connect the shared termination impedance circuit **190** to either end of the selected section. While a three section coupled line is illustrated in FIG. **24**, the principles and advantages of the embodiment of FIG. **24** can be applied in connection with a two section coupled line or a coupled line having four or more sections. While the shared termination impedance circuit **190** is shown for illustrative purposes, a shared termination impedance circuit having one or more features of any of the termination circuits discussed herein can alternatively be implemented.

FIG. **25A** is a schematic diagram of an electronic system that includes a radio frequency coupler having a multi-section coupled line, a plurality of termination impedance circuits **250a** to **250d**, and a switch network **240**, according to an embodiment.

In FIG. **25A**, the switch network **240** includes switches **251**, **252**, **253**, **254**, **255**, and **256**. The switch network **240** can receive one or more control signals from control circuit **58"** and can selectively electrically connect a selected termination impedance circuit **250a**, **250b**, **250c**, or **250d** to a selected end of a section **85** or **87** of the multi-section coupled line. For instance, the switch **252** can selectively electrically connect a first termination impedance circuit **250a** to a first end of the first section **85** responsive to a control signal provided by the control circuit **58"**. As another example, the switch **253** can selectively electrically connect a second termination impedance circuit **250b** to a second end of the first section **85** responsive to a control signal provided by the control circuit **58"**. The switch network **240** can electrically decouple all of the termination impedance cir-

uits **250a**, **250b**, **250c**, and **250d** from the first section **85** and the second section **87** in a decoupled state.

The switches **251** and **255** of the switch network **240** and the coupling factor switches **90A** and **90B** can electrically connect a selected end of a section **85** or **87** to a power output port Power Out. The coupling factor switches **90A** and **90B** can be considered part of a switch network that also includes the switch network **240**. In FIG. **25A**, a single power output port Power Out is provided to provide either an indication of forward power or an indication of reverse power. A single output port can be implemented in connection with any of the other embodiments discussed herein by including additional switches and/or modifying the switch networks of the other embodiments.

In certain embodiments, a separate termination impedance circuit having an adjustable termination impedance can be implemented for each of two or more sections of a multi-section coupled line. According to some embodiments, separate termination impedance circuits can be implemented for each end of a section of a multi-section coupled line. As illustrated in FIG. **25A**, a first termination impedance circuit **250a** is electrically collected to a first end of a first section **85** of the coupled line, a second termination impedance circuit **250b** is electrically connected to a second end of the first section **85** of the coupled line, a third termination impedance circuit **250c** is electrically collected to a first end of the second section **87** of the coupled line, and a fourth termination impedance circuit **250d** is electrically collected to a second end of the second section **87** of the coupled line.

In FIG. **25A**, each of the termination impedance circuits **250a**, **250b**, **250c**, and **250d** includes an RLC circuit having an adjustable termination impedance. The control circuit **58"** can provide one or more control signals to adjust the termination impedance of the termination impedance circuits **250a**, **250b**, **250c**, and/or **250d**. While an example termination impedance circuit **250a** will be discussed with reference to FIG. **25B** for illustrative purposes, it will be understood that any of the principles and advantages discussed herein related to termination impedance circuits can alternatively be implemented. Moreover, one or more of the termination impedance circuits **250b**, **250c**, or **250d** can be substantially the same as the termination impedance circuit **250a** in certain embodiments. According to some embodiments, one or more of the termination impedance circuits **250b**, **250c**, or **250d** can be different than the termination impedance circuit **250a**.

FIG. **25B** illustrates an example termination impedance circuit **250a** of FIG. **25A**, according to an embodiment. Any of the principles and advantages of the termination impedance circuit **250a** can be implemented in connection with any of the other embodiments discussed herein, including embodiments with multi-section coupled lines and embodiments with a continuous coupled line. As illustrated, the termination impedance circuit **250a** is an adjustable RLC circuit. The termination impedance circuit **250a** can include a fixed impedance portion and an adjustable impedance portion.

The fixed impedance portion can include one or more resistors, one or more capacitors, one or more inductors, or any suitable series and/or parallel combination thereof. For instance, the fixed impedance portion can include a parallel RC circuit. The fixed impedance portion can include a series RL circuit. The fixed impedance portion can include a series LC circuit. As illustrated in FIG. **25B**, the fixed impedance portion of the termination impedance circuit **250a** includes

a parallel RC circuit, which includes resistor R_{25} in parallel with capacitor C_{25} , in series with an inductor L_{25} .

The adjustable impedance portion can include a plurality of passive impedance elements and a plurality of switches. Alternatively or additionally, the adjustable impedance portion can include varactor(s) and/or other variable impedance element(s). For example, the adjustable impedance portion can include one or more capacitors and one or more corresponding switches configured to selectively switch in and selectively switch out the impedance of a respective capacitor. As another example, the adjustable impedance portion can include one or more resistors and one or more corresponding switches configured to selectively switch in and selectively switch out the impedance of a respective resistor. As illustrated in FIG. 25B, the termination impedance circuit 250a includes switches 257A, 257B, 258a1, 258a2, 258a3, 258a4, 258b1, 258b2, 258b3, and 258b4, capacitors C_{25a1} , C_{25a2} , C_{25b1} , and C_{25b2} , and resistors R_{25a1} , R_{25a2} , R_{25b1} , and R_{25b2} . The illustrated switches can receive signals from a control circuit, such as the control circuit 58" of FIG. 25A, and selectively electrically couple a respective passive impedance element between ground and a section of a multi-section coupled line. Zero, one, or more of the illustrated switches can be on at the same time. To avoid having more switches than desired coupled to a particular node, the switches can branch such that no more than a certain number of switches (e.g., 4 as illustrated) are directly connected to a particular node. As illustrated, switches 257A and 257B can selectively electrically connect respective switch banks to a port of an RF coupler. Switches 258a1, 258a2, 258a3, 258a4, 258b1, 258b2, 258b3, and 258b4 of the switch banks can selectively switch in and selectively switch out impedances of respective passive impedance elements in parallel with the parallel RC circuit that includes the resistor R_{25} in parallel with the capacitor C_{25} . The illustrated resistors and capacitors of the adjustable impedance portion can have any suitable impedance values for a particular application.

The termination impedance circuit 250 includes passive impedance elements coupled in series between a switch and ground, in which the switch is coupled between a port of an RF coupler and the series passive impedance elements. The passive impedance elements in series can include an inductor and a resistor and an inductor and a capacitor, as illustrated. More generally, the passive impedance elements in series can include a resistor and another type of passive impedance element, a capacitor and another type of passive impedance element, or an inductor and another type of passive impedance element.

The radio frequency couplers described herein can be implemented in a variety of different modules including, for example, a stand-alone radio frequency coupler, an antenna switch module, a module combining a radio frequency coupler and an antenna switch module, an impedance matching module, an antenna tuning module, or the like. FIGS. 26A to 26C illustrate example modules that can include any of the radio frequency couplers discussed herein. These example modules can include any combination of features associated with radio frequency couplers, termination impedance circuits, switch networks and/or switch circuits, or the like.

FIG. 26A is a block diagram of a packaged module 260 that includes a radio frequency coupler. The packaged module 260 includes a package 262 that encases an RF coupler 20. The packaged module 260 can include contacts, such as pins, sockets, ball, lands, etc., corresponding to each port of the RF coupler 20. In some embodiments, the packaged module 260 can include a first contact correspond-

ing to a power input port, a second contact corresponding to a power output port, a third contact corresponding to a forward coupled output, and a fourth contact corresponding to a reverse coupled output. According to another embodiment, the packaged module 260 can include a single contact for output power corresponding to either forward power or reverse power depending on the state of switches in the packaged module 260. Termination impedance circuits and/or switches in accordance with any of the principles and advantages discussed herein can be included within the package 262 of any of the example modules illustrated in FIGS. 26A to 26C.

FIG. 26B is a block diagram of a packaged module 265 that includes a radio frequency coupler 20 and an antenna switch module 40. In FIG. 26B, a package 262 encases both the RF coupler 20 and the antenna switch module 40. FIG. 26C is a block diagram of a packaged module 267 that includes a radio frequency coupler 20, an antenna switch module 40, and a power amplifier 10. The packaged module 267 includes these elements within a common package 262.

FIG. 27 illustrates an example wireless device 270 that can include one or more radio frequency couplers having one or more features discussed herein. For instance, the example wireless device 270 can include an RF coupler in accordance with any of the principles and advantages discussed with reference to any of the RF couplers of FIGS. 3A, 4, 5, 7A, 8A, 9A, 10A, 13A, 14, 15, 16A, 17A, 19A, or 20 to 25A. The example wireless device 270 can be a mobile phone, such as a smart phone. The example wireless device 270 can include elements that are not illustrated in FIG. 27 and/or a subcombination of the illustrated elements.

The example wireless device 270 depicted in FIG. 27 can represent a multi-band and/or multi-mode device such as a multi-band/multi-mode mobile phone. By way of example, the wireless device 270 can communicate in accordance with Long Term Evolution (LTE). In this example, the wireless device can be configured to operate at one or more frequency bands defined by an LTE standard. The wireless device 270 can alternatively or additionally be configured to communicate in accordance with one or more other communication standards, including but not limited to one or more of a Wi-Fi standard, a Bluetooth standard, a 3G standard, a 4G standard or an Advanced LTE standard.

As illustrated, the wireless device 270 can include a transceiver 273, an antenna switch module 40, an RF coupler 20, an antenna 30, power amplifiers 10, a control component 278, a computer readable storage medium 279, a processor 280, and a battery 271.

The transceiver 273 can generate RF signals for transmission via the antenna 30. Furthermore, the transceiver 273 can receive incoming RF signals from the antenna 30. It will be understood that various functionalities associated with transmitting and receiving of RF signals can be achieved by one or more components that are collectively represented in FIG. 27 as the transceiver 273. For example, a single component can be configured to provide both transmitting and receiving functionalities. In another example, transmitting and receiving functionalities can be provided by separate components.

In FIG. 27, one or more output signals from the transceiver 273 are depicted as being provided to the antenna 30 via one or more transmission paths 275. In the example shown, different transmission paths 275 can represent output paths associated with different frequency bands (e.g., a high band and a low band) and/or different power outputs. One or more of the transmission paths 275 can be associated with different transmission modes. One of the illustrated trans-

mission paths **275** can be active while one or more of the other transmission paths **275** are non-active. Other transmission paths **275** can be associated with different power modes (e.g., high power mode and low power mode) and/or paths associated with different transmit frequency bands. The transmit paths **275** can include one or more power amplifiers **10** to aid in boosting an RF signal having a relatively low power to a higher power suitable for transmission. As illustrated, the power amplifiers **10a** and **10b** can include the power amplifiers **10** discussed above. The wireless device **270** can be adapted to include any suitable number of transmission paths **275**.

In FIG. **27**, one or more signals from the antenna **30** are depicted as being provided to the transceiver **273** via one or more receive paths **277**. In the example shown, different receive paths **277** can represent paths associated with different signaling modes and/or different receive frequency bands. The wireless device **270** can be adapted to include any suitable number of receive paths **277**.

To facilitate switching between receive and/or transmit paths, the antenna switch module **40** can be included and can be used to selectively electrically connect the antenna **30** to a selected transmit or receive path. Thus, the antenna switch module **40** can provide a number of switching functionalities associated with an operation of the wireless device **270**. The antenna switch module **40** can include a multi-throw switch configured to provide functionalities associated with, for example, switching between different bands, switching between different modes, switching between transmission and receiving modes, or any combination thereof.

The RF coupler **20** can be disposed between the antenna switch module **40** and the antenna **30**. The RF coupler **20** can provide an indication of forward power provided to the antenna **30** and/or an indication of reverse power reflected from the antenna **30**. The indications of forward and reverse power can be used, for example, to compute a reflected power ratio, such as a return loss, a reflection coefficient, or a voltage standing wave ratio (VSWR). The RF coupler **20** illustrated in FIG. **27** can implement any of the principles and advantages of the RF couplers discussed herein.

FIG. **27** illustrates that in certain embodiments, the control component **278** can be provided for controlling various control functionalities associated with operations of the antenna switch module **40** and/or other operating component (s). For example, the control component **278** can aid in providing control signals to the antenna switch module **40** so as to select a particular transmit or receive path. As another example, the control component **278** can provide control signals to configure the RF coupler **20** and/or an associated termination impedance circuit and/or an associated switch network in accordance with any of the principles and advantages discussed herein.

In certain embodiments, the processor **280** can be configured to facilitate implementation of various processes on the wireless device **270**. The processor **280** can be, for example, a general purpose processor or special purpose processor. In certain implementations, the wireless device **270** can include a non-transitory computer-readable medium **279**, such as a memory, which can store computer program instructions that may be provided to and executed by the processor **280**.

The battery **271** can be any suitable battery for use in the wireless device **270**, including, for example, a lithium-ion battery.

Some of the embodiments described above have provided examples in connection with power amplifiers and/or mobile devices. However, the principles and advantages of the

embodiments can be used for any other systems or apparatus, such as any uplink cellular device, that could benefit from any of the circuits described herein. Any of the principles and advantages discussed herein can be implemented in an electronic system with a need for detecting and/or monitoring a power level associated with an RF signal, such as forward RF power and/or a reverse RF power. Any of the switch networks and/or switch circuit discussed herein can alternatively or additionally be implemented by any other suitable logically equivalent and/or functionally equivalent switch networks. The teachings herein are applicable to a variety of power amplifier systems including systems with multiple power amplifiers, including, for example, multi-band and/or multi-mode power amplifier systems. The power amplifier transistors discussed herein can be, for example, gallium arsenide (GaAs), complementary metal oxide semiconductor (CMOS), or silicon germanium (SiGe) transistors. Moreover, power amplifiers discussed herein can be implemented by FETs and/or bipolar transistors, such as heterojunction bipolar transistors.

Aspects of this disclosure can be implemented in various electronic devices. Examples of the electronic devices can include, but are not limited to, consumer electronic products, parts of the consumer electronic products, electronic test equipment, cellular communications infrastructure such as a base station, etc. Examples of the electronic devices can include, but are not limited to, a mobile phone such as a smart phone, a telephone, a television, a computer monitor, a computer, a modem, a hand-held computer, a laptop computer, a tablet computer, an electronic book reader, a wearable computer such as a smart watch, a personal digital assistant (PDA), a microwave, a refrigerator, a stereo system, a DVD player, a CD player, a digital music player such as an MP3 player, a radio, a camcorder, a camera, a digital camera, a portable memory chip, a health care monitoring device, a vehicular electronics system such as an automotive electronics system or an avionics electronic system, a washer, a dryer, a washer/dryer, a peripheral device, a wrist watch, a clock, etc. Further, the electronic devices can include unfinished products.

Unless the context clearly requires otherwise, throughout the description and the claims, the words “comprise,” “comprising,” and the like are to be construed in an inclusive sense, as opposed to an exclusive or exhaustive sense; that is to say, in the sense of “including, but not limited to.” The words “electrically coupled”, as generally used herein, refer to two or more elements that may be either directly electrically connected, or electrically connected by way of one or more intermediate elements. Likewise, the word “connected”, as generally used herein, refers to two or more elements that may be either directly connected, or connected by way of one or more intermediate elements. Additionally, the words “herein,” “above,” “below,” and words of similar import, when used in this application, shall refer to this application as a whole and not to any particular portions of this application. Where the context permits, words in the above Detailed Description of Certain Embodiments using the singular or plural number may also include the plural or singular number, respectively. The word “or” in reference to a list of two or more items, where context permits, covers all of the following interpretations of the word: any of the items in the list, all of the items in the list, and any combination of the items in the list.

Moreover, conditional language used herein, such as, among others, “can,” “could,” “might,” “may,” “e.g.,” “for example,” “such as” and the like, unless specifically stated otherwise, or otherwise understood within the context as

used, is generally intended to convey that certain embodiments include, while other embodiments do not include, certain features, elements and/or states. Thus, such conditional language is not generally intended to imply that features, elements and/or states are in any way required for one or more embodiments or that one or more embodiments necessarily include logic for deciding, with or without author input or prompting, whether these features, elements and/or states are included or are to be performed in any particular embodiment.

While certain embodiments have been described, these embodiments have been presented by way of example only, and are not intended to limit the scope of the disclosure. Indeed, the novel apparatus, methods, and systems described herein may be embodied in a variety of other forms; furthermore, various omissions, substitutions and changes in the form of the methods and systems described herein may be made without departing from the spirit of the disclosure. For example, while blocks are presented in a given arrangement, alternative embodiments may perform similar functionalities with different components and/or circuit topologies, and some blocks may be deleted, moved, added, subdivided, combined, and/or modified. Each of these blocks may be implemented in a variety of different ways. Any suitable combination of the elements and acts of the various embodiments described above can be combined to provide further embodiments. The accompanying claims and their equivalents are intended to cover such forms or modifications as would fall within the scope and spirit of the disclosure.

What is claimed is:

1. A radio frequency coupler comprising:

a power input port, a power output port, a coupled port, and an isolation port;

a main transmission line electrically connected between the power input port and the power output port;

a multi-section coupled line having a first section, a second section, and a third section, an effective length of the multi-section coupled line being a length of the multi-section coupled line electrically connected between the coupled port and the isolation port, the multi-section coupled line being configured to electromagnetically couple a portion of radio frequency power traveling between the power input port and the power output port to provide coupled power at the coupled port;

a first switch disposed in series between the first and second sections of the multi-section coupled line and configured to adjust the effective length of the multi-section coupled line by selectively electrically connecting the first section to the second section; and

a second switch disposed in series between the second and third sections of the multi-section coupled line and configured to further adjust the effective length of the multi-section coupled line by selectively electrically connecting the third section to one of the first section and the second section.

2. The radio frequency coupler of claim **1** further comprising a termination impedance coupled to the isolation port.

3. The radio frequency coupler of claim **1** further comprising a first termination impedance element electrically coupleable to the first section of the multi-section coupled line and a second termination impedance element electrically coupleable to the second section of the multi-section coupled line.

4. The radio frequency coupler of claim **1** further comprising an adjustable termination impedance circuit electrically coupleable to the first section of the multi-section coupled line, the adjustable termination impedance circuit configured to provide a termination impedance to the first section of the multi-section coupled line.

5. The radio frequency coupler of claim **1** further comprising an adjustable termination impedance circuit and a switch network, the switch network configured to selectively electrically couple the adjustable termination impedance circuit to the first section of the multi-section coupled line and to selectively electrically couple the adjustable termination impedance circuit to the second section of the multi-section coupled line.

6. The radio frequency coupler of claim **1** wherein the main transmission line is implemented by a continuous conductive structure electrically connecting the power input port and the power output port.

7. The radio frequency coupler of claim **1** further configured to operate in a decoupled state in which each section of the multi-section coupled line is decoupled from the main transmission line electrically connecting the power input port and the power output port.

8. The radio frequency coupler of claim **1** further comprising a switch network arranged to configure the radio frequency coupler into a first state to provide an indication of forward power and into a second state to provide an indication of reflected power.

9. The radio frequency coupler of claim **1** further comprising a control circuit configured to adjust a state of the first switch and the second switch.

10. The radio frequency coupler of claim **1** further comprising a switch network configured to electrically couple a first impedance element to a first end of the first section of the multi-section coupled line and electrically couple a second end of the first section of the multi-section coupled line to the coupled port in a first state, and to electrically couple a second impedance element to a first end of the second section of the multi-section coupled line and electrically couple a second end of the second section of the multi-section coupled line to the coupled port in a second state.

11. The radio frequency coupler of claim **1** further comprising a package enclosing the radio frequency coupler.

12. The radio frequency coupler of claim **11** further comprising an antenna switch module in communication with one of the power input port and the power output port, the antenna switch module enclosed within the package.

13. The radio frequency coupler of claim **12** further comprising a power amplifier configured to provide a radio frequency signal to the antenna switch module, the power amplifier enclosed within the package.

14. A radio frequency coupler comprising:

a power input port, a power output port, and a port configured to provide an indication of power of a radio frequency signal traveling between the power input port and the power output port;

a main transmission line electrically connected between the power input port and the power output port;

a multi-section coupled line having a first section, a second section, and a third section, an effective length of the multi-section coupled line being a length of the multi-section coupled line electrically connected between the port configured to provide the indication of power and a termination impedance, the multi-section coupled line being configured to electromagnetically

51

couple a portion of the radio frequency signal to provide the indication of power;

a first switch disposed in series between the first and second sections of the multi-section coupled line and configured to adjust the effective length of the multi-section coupled line by selectively electrically connecting the first section to the second section; and

a second switch disposed in series between the second and third sections of the multi-section coupled line and configured to further adjust the effective length of the multi-section coupled line by selectively electrically connecting the third section to one of the first section and the second section.

15. The radio frequency coupler of claim 14 wherein the radio frequency coupler includes a coupled port and the coupled port is the port configured to provide the indication of power, the indication of power being indicative of power traveling from the power input port to the power output port.

16. The radio frequency coupler of claim 14 wherein the radio frequency coupler includes an isolated port and the isolated port is the port configured to provide the indication of power, the indication of power being indicative of power traveling from the power output port to the power input port.

17. The radio frequency coupler of claim 14 further comprising an adjustable termination impedance circuit and a switch network, the switch network configured to selectively electrically couple the adjustable termination impedance circuit to the first section of the multi-section coupled line and to selectively electrically couple the adjustable termination impedance circuit to the second section of the multi-section coupled line.

18. The radio frequency coupler of claim 14 further comprising a switch network arranged to configure the radio frequency coupler into a first state to provide an indication

52

of forward power of the radio frequency signal and into a second state to provide an indication of reflected power of the radio frequency signal.

19. A radio frequency coupler comprising: a power input port, a power output port, and a coupled port, and; a multi-section coupled line having a first section, a second section, and a third section selectively electrically connectable to each other and electrically connected between the coupled port and a termination impedance to provide an adjustable effective length, each of the first section, the second section, and the third section selectively contributing to a coupling factor of the radio frequency coupler; and a switch network arranged to configure the radio frequency coupler into a first state to provide an indication of forward power of the radio frequency signal and into a second state to provide an indication of reflected power of the radio frequency signal.

20. The radio frequency coupler of claim 19 wherein each section of the multi-section coupled line is selectively electrically coupleable to the coupled port.

21. The radio frequency coupler of claim 20 wherein the radio frequency coupler further includes a switch disposed between two adjacent sections of the multi-section coupled line, the switch configured to selectively electrically couple the two adjacent sections to each other responsive to a control signal.

22. The radio frequency coupler of claim 19 wherein the termination impedance is an adjustable termination impedance circuit including a switch network, the switch network configured to selectively electrically couple the adjustable termination impedance circuit to the first section of the multi-section coupled line and to selectively electrically couple the adjustable termination impedance circuit to the second section of the multi-section coupled line.

* * * * *