

US009796855B2

(12) **United States Patent**
Howle

(10) **Patent No.:** **US 9,796,855 B2**
(45) **Date of Patent:** **Oct. 24, 2017**

(54) **TWO PART COMPOSITION FOR CONCRETE SURFACES**

(71) Applicant: **Clint A Howle**, Springdale, AR (US)

(72) Inventor: **Clint A Howle**, Springdale, AR (US)

(73) Assignee: **AMERIPOLISH Inc.**, Lowell, AR (US)

(*) Notice: Subject to any disclaimer, the term of this patent is extended or adjusted under 35 U.S.C. 154(b) by 46 days.

(21) Appl. No.: **14/182,275**

(22) Filed: **Feb. 17, 2014**

(65) **Prior Publication Data**

US 2014/0373287 A1 Dec. 25, 2014

Related U.S. Application Data

(63) Continuation of application No. 11/709,617, filed on Feb. 22, 2007, now Pat. No. 8,652,219.

(60) Provisional application No. 60/775,514, filed on Feb. 22, 2006.

(51) **Int. Cl.**

C09B 56/14	(2006.01)
C09B 67/22	(2006.01)
C09B 47/04	(2006.01)
D06P 3/80	(2006.01)
D06P 1/14	(2006.01)
D06P 1/18	(2006.01)
C09B 57/00	(2006.01)
C09B 67/42	(2006.01)

(52) **U.S. Cl.**

CPC **C09B 56/14** (2013.01); **C09B 47/04** (2013.01); **C09B 57/00** (2013.01); **C09B 67/0041** (2013.01); **C09B 67/0042** (2013.01); **C09B 67/0092** (2013.01); **D06P 1/14** (2013.01); **D06P 1/18** (2013.01); **D06P 3/80** (2013.01)

(58) **Field of Classification Search**

CPC C09B 67/0042
See application file for complete search history.

(56) **References Cited**

U.S. PATENT DOCUMENTS

6,423,132 B2 *	7/2002	Balliello	106/493
2003/0199608 A1 *	10/2003	Kamigaki	B82Y 30/00
			523/160
2006/0229382 A1 *	10/2006	Schweikart	C09D 11/38
			523/160

FOREIGN PATENT DOCUMENTS

DE	WO 2004094541 A1 *	11/2004	C09D 11/322
GB	1529062 A *	10/1978	B65D 25/40

* cited by examiner

Primary Examiner — Katie L Hammer

(74) *Attorney, Agent, or Firm* — Isaac Angres

(57) **ABSTRACT**

The invention herein provides for an improved dye material composed of a dry particulate mixture of azo and phthalocyanine dyes for concrete surface applications.

1 Claim, 3 Drawing Sheets

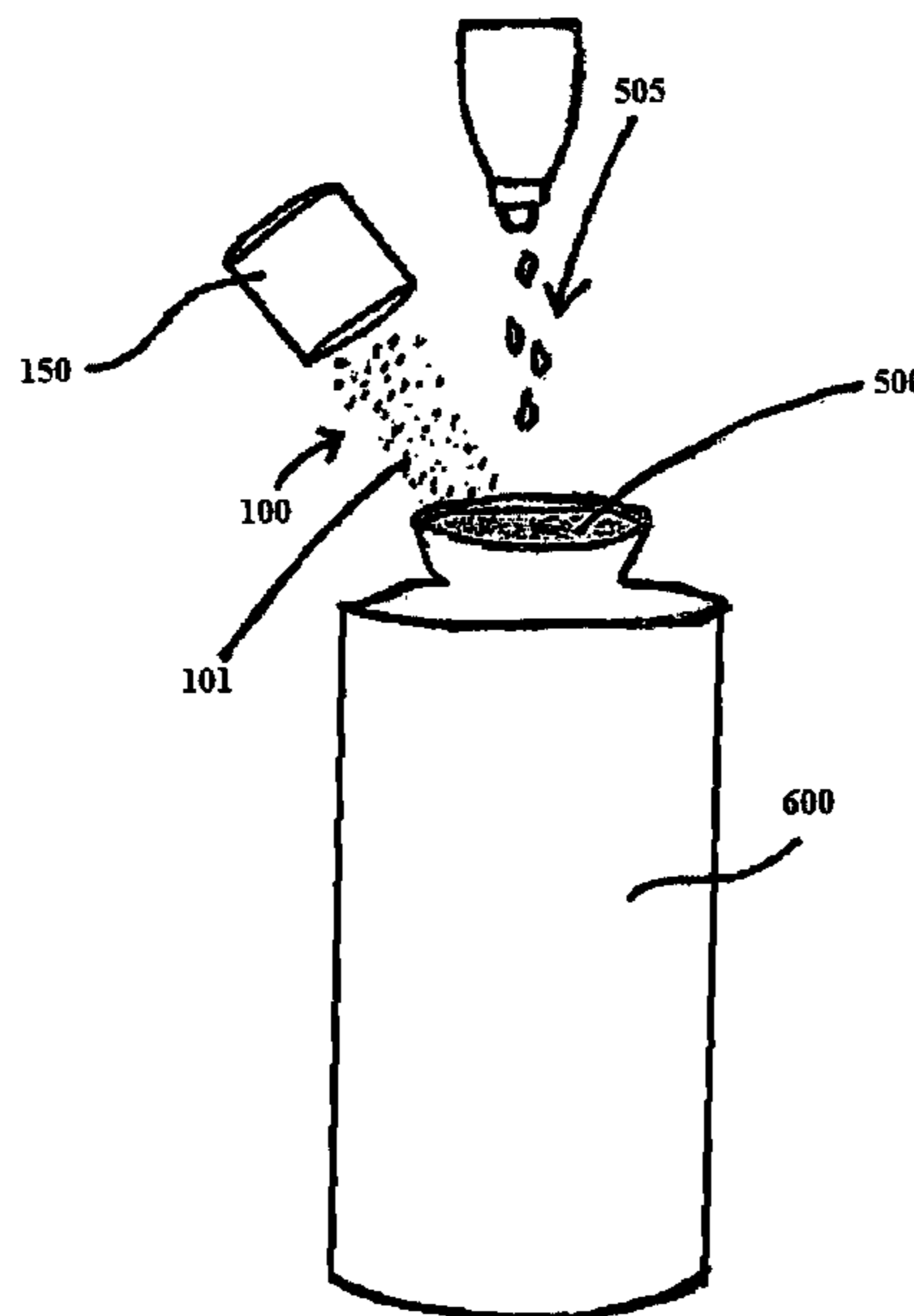

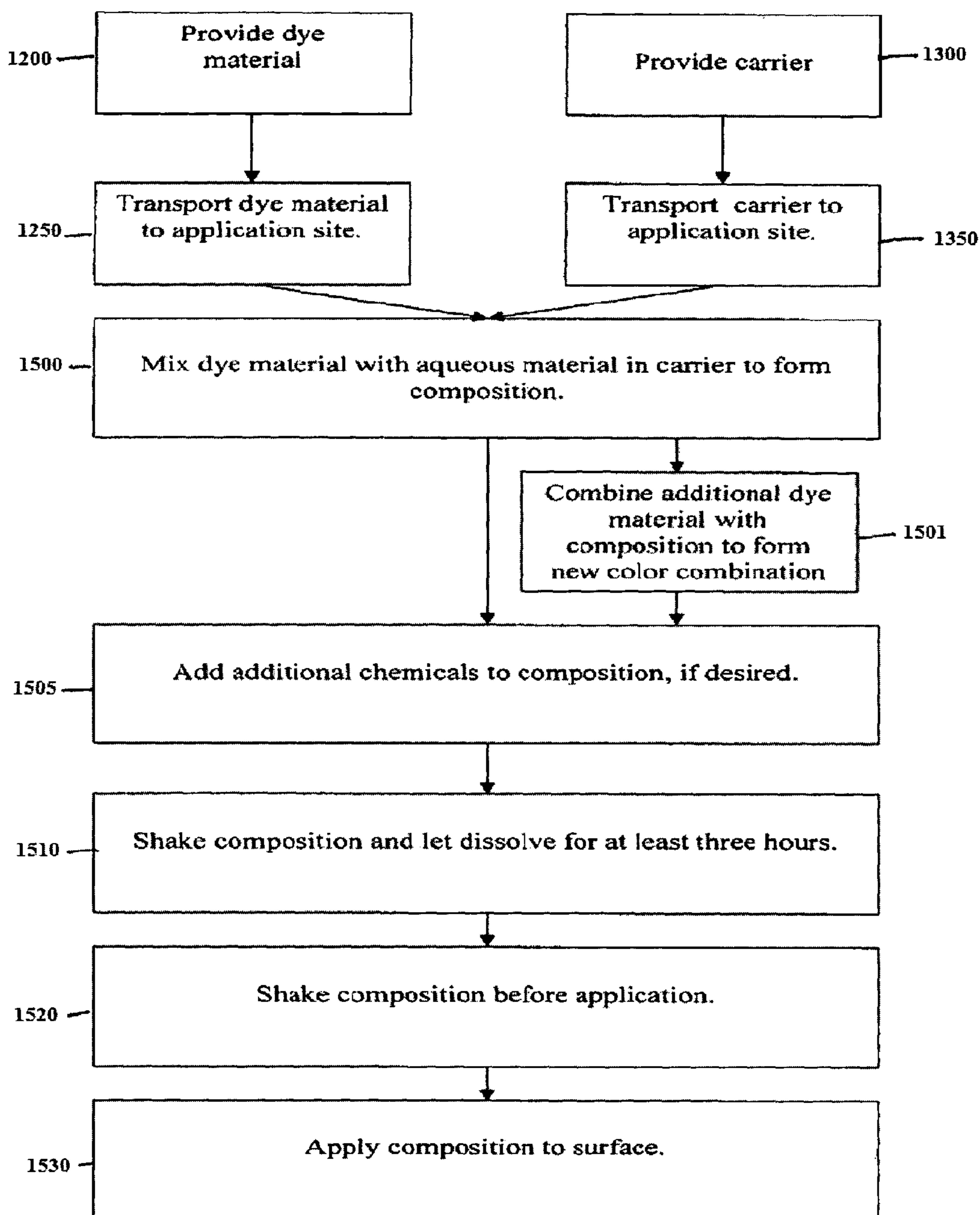

Figure 1

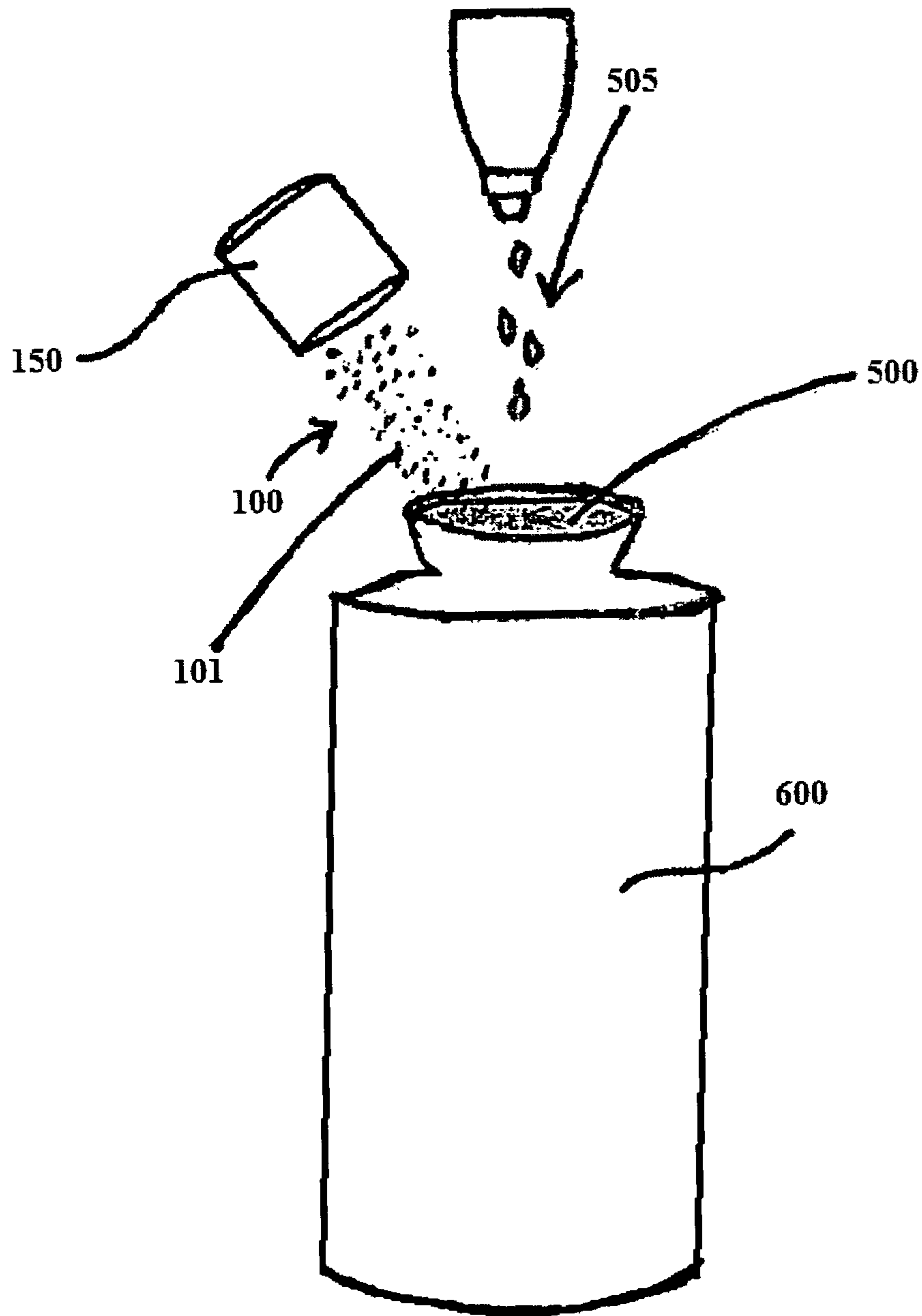

Fig. 2

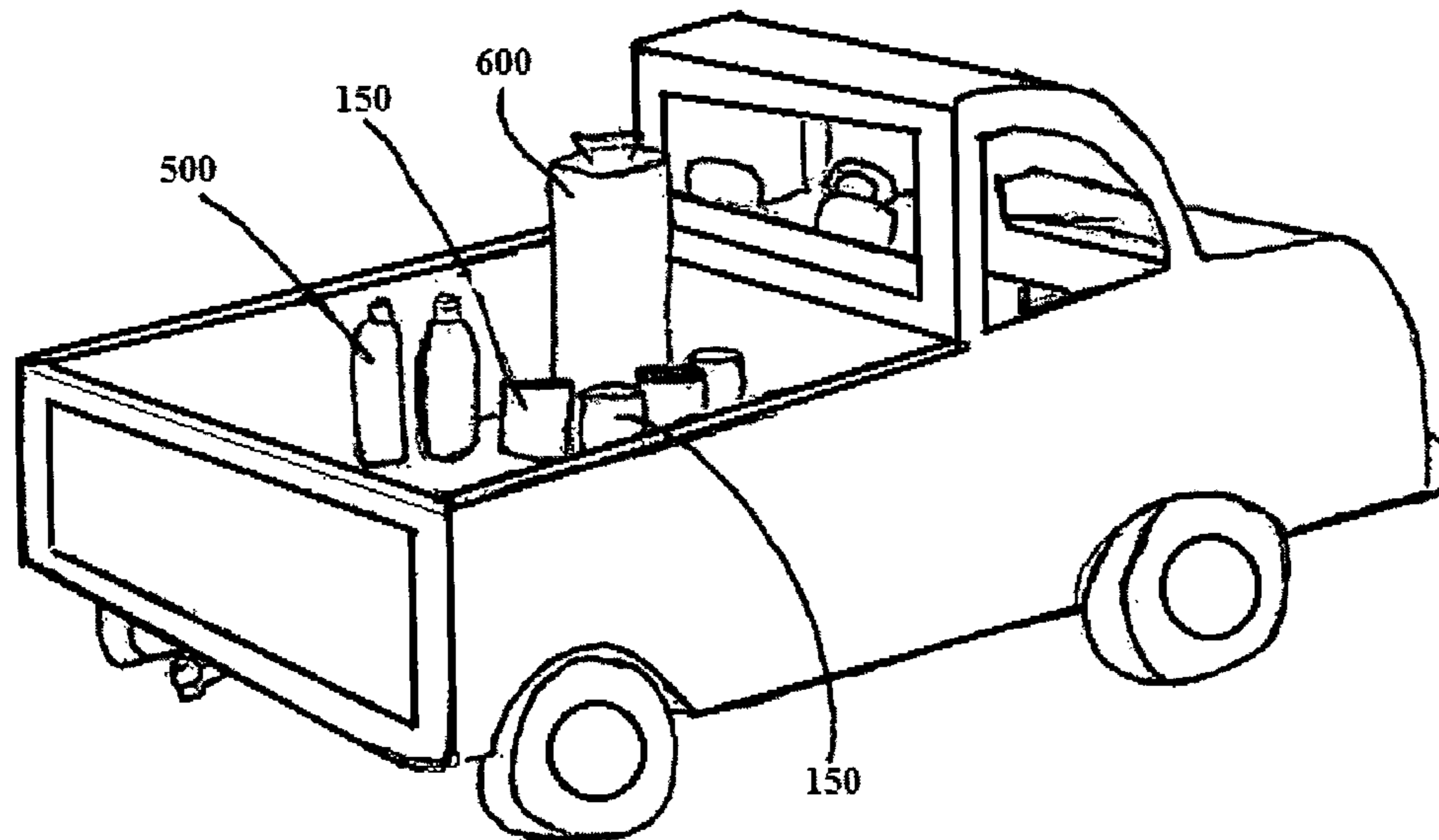

Fig. 3

TWO PART COMPOSITION FOR CONCRETE SURFACES

This Application is a continuation of U.S. application Ser. No. 11/709,617 filed Feb. 22, 2007, now U.S. Pat. No. 8,652,219 which issued Feb. 18, 2014. This application also claims the priority benefit under 35 U.S.C. section 119 of U.S. Provisional Patent Application No. 60/775,514 filed Feb. 22, 2006 entitled "Dye Material". The contents of all the Applications mentioned above are incorporated by reference in their entirety.

FIELD OF THE INVENTION

The invention relates to dye material used for treating existing surfaces, such as cured concrete. In particular, the invention pertains to powder dye material used for treating a variety of surfaces including concrete. Known are may be found in U.S. Class 428, subclass 511 and others.

BACKGROUND OF THE INVENTION

Hazardous base dye compositions have been employed in the construction field to apply single colors and textures during the formation of surfaces. Similar technology has also been used to apply chemical formulas to create a desired finish upon a cured concrete surface. In the past, these dye materials have been limited to a single color base that included hazardous materials which complicate the shipping of these materials. Thus, shipping of multiple colors or combining colors required multiple hazardous material shipments. Furthermore, this created problems in adapting a varying color surfaces because adjustment could not be easily made to the formulation being applied. Additionally, the past dye formulations had a limited shelf-life that required concurrent ordering of the hazardous material dyes with the job such that custom coloring could not be easily provided. Thus, there is an overwhelming need in the art to provide an easily-transportable dye material that is not considered a hazardous material that also has an extended shelf-life. Further, there is need for the ability to provide materials that may be custom blended at the job site without the waste associated with prior art methods.

U.S. Pat. No. 4,162,348 to Juzu et al. shows a method for coloring inorganic substrates such as glass beads, glass fibers, mineral wool, rock wool, mineral fiber boards and cloths, concrete molded materials, inorganic pigment and metallic powders, which comprises treating the inorganic substrate with (1) a cationic component comprising (a) a water soluble cationic resin or an aqueous solution of a water soluble cationic resin, (b) an aqueous solution of a water soluble cationic resin and a water soluble cationic dye, or (c) an aqueous dispersion of a water soluble cationic resin, a cationic dispersing agent plus a water insoluble dye or pigment and, optionally, a cationic water soluble dye; and With (2) an anionic component comprising (d) an aqueous solution of a water soluble anionic dye, (e) an anionic dispersing agent or an aqueous solution of an anionic dispersing agent, (f) an aqueous solution of an anionic dispersing agent and a water soluble anionic dye, or (g) an aqueous dispersion of an anionic dispersing agent plus a water insoluble dye or pigment and, optionally, an anionic water soluble dye with the order of treatment with the cationic component (1) and the anionic component (2) being optional and with at least one of the cationic component (1) or the anionic component (2) containing a dye, either water soluble or water insoluble, or pigment as a colorant.

U.S. Pat. No. 5,476,722 to Sakamoto et al. shows a concrete coloring material and a process for coloring concrete by means of such a concrete coloring material capable of permitting concrete to exhibit natural color or aesthetic properties while preventing concrete from being substantially discolored. Polyethylene oxide is used as a water-soluble adhesive or glue. The oxide is mixed with a composition such as dye, pigment, a mixture thereof or the like, to thereby permit the composition to penetrate into the concrete.

U.S. Pat. No. 5,534,214 to Sakamoto et al. shows a concrete coloring material and a process for coloring concrete by means of such a concrete coloring material capable of permitting concrete to exhibit natural color or aesthetic properties while preventing concrete from being substantially discolored. Polyethylene oxide is used as a water-soluble adhesive or glue. The oxide is mixed with a composition such as dye, pigment, a mixture thereof or the like, to thereby permit the composition to penetrate into the concrete.

The prior art fails to teach a dye material shipped in its powder form. Additionally, the prior art fails to teach a dye material with an extended shelf-life. Thus, there is a need in the art to provide a dye application that is easily transported, non-hazardous, with an extended shelf-life.

SUMMARY OF THE INVENTION

The invention provides for an improved dye material used to treat existing surfaces, namely, cured concrete. In particular, the powder dye material is transportable in a non-hazardous dry powder form which may be stored for an extended period and then custom mixed with an aqueous material for application to existing concrete surfaces. The improved dye material eliminates the voluminous, cumbersome, weighty packaging materials used with previous dye materials for concrete surfaces.

Further, the powder form dye material is an ideal for transportation and storage as it is non-hazardous and has an extended shelf-life. Packaging of the improved powder dye material is considerably more compact and lighter, allowing for more efficient shipping and storage of the dye material. This allows for multiple colors of dye to be easily transported for custom blending at the jobsite with the materials easily stored on the transportation vehicle with just a single transportation of a base liquid material that may or may not be hazardous.

An object of the present invention is to provide an improved dye material for treatment of existing surfaces.

Another object of the present invention is to provide a dye material that is easily transported.

Another object of the present invention is to provide a dye material which is compact and light.

Yet another object of the present invention is to provide a non-hazardous dye material.

A still further object of the present invention is to provide a method for providing on site custom blending without the multiple volumes of hazardous material required by the prior art.

These and other objects and advantages of the present invention, along with the features of novelty appurtenant thereto, will appear or become apparent by reviewing the following detailed description of the invention.

BRIEF DESCRIPTION OF THE DRAWINGS

In the following drawings, which form a part of the specification and which are to be construed in conjunction

therewith, and in which like reference numerals have been employed throughout wherever possible to indicate like parts of the various views:

FIG. 1 is a flow chart illustrating a method of using the improved dye material;

FIG. 2 is a drawing showing a step of the method of using the improved dye material;

FIG. 3 is a drawing showing a step thereof.

DETAILED DESCRIPTION OF THE INVENTION

The present invention addresses a perceived need in the art for an improved dye material. In particular, the present invention discloses the use of a non-hazardous powder dye material for on site mixing with a base material for treating of concrete surfaces.

FIG. 2 shows the main advantage of the present invention by showing the on site mixing of a dry powder dye material **100** with a chemical solution **500**. The powder dye material in accordance with the present invention is generally indicated by reference numeral **100** in FIG. 2. The powder dye material **100** generally is added to an aqueous material **500** prior to application upon concrete surfaces. The aqueous material **500** may include a variety of solvents, such as acetone or water.

Powder dye material **100**, as shown in FIG. 2, is composed of a dry particulate **101** mixture of azo and phthalocyanine dyes. It is expected that the ratio of azo and phthalocyanine dyes in the dry particles **101** of the dye material **100** can be altered to create different colors. For example, in a preferred embodiment, a deep green dye can be achieved by mixing yellow azo dye and red azo dye, and blue phthalocyanine dye. Specifically, for a five pound mixture **101** of deep green dye material **100** can be achieved by combining 945 grams of yellow azo dye, 378 grams of red azo dye, and 945 grams of blue phthalocyanine dye.

As will be appreciated by one skilled in the art decorative concrete finishes may include many various colors requiring many differing dye materials. Also known is that concrete pads may have varying colors across their surfaces requiring the use of multiple color combinations to achieve a uniform dye effect. As shown in FIG. 3, the present invention provides for this capability while limiting the amount of aqueous material by providing a multitude of dye material **100** in a variety of colors that may be stored and shipped with a small volume of aqueous material **500**. Alternatively, two shipments may be utilized wherein one is for the non-hazardous dye material and a second shipment is used for the aqueous material **500**. This allows for multiple colors with just a single purchase and shipment of one amount of aqueous material **500**.

The present invention allows for a user to purchase and use smaller lightweight amounts of dry dye material **100** for mixing with one base aqueous material **500**. This advantage allows users to save storage space and money while promoting efficiency in the industry. Dye material **100** is non-hazardous, allowing for less costly method of shipment and storage than aqueous dye materials or alternatively, allowing for faster shipment, such as air shipment, tunnel shipments, or the like, of materials to provide better customer service. Further, dye material **100** does not contain the aqueous elements or hazardous chemicals used in the previous dye application until a few hours prior to surface application, so the powder dye material **100** is safer than hazardous dye materials which lowers the risk to all of society in the transportation of these materials.

The color of the dye material **100** may be easily modified by a user by combining various colors of dye material **100** to create custom colors. The improved dry dye material **100** allows for increased mixture of dye colors to create additional dye colors for applications. The present invention enables easier color customization by presenting a dye material **100** which is non-hazardous and easy to mix. Thus, users do not have to be concerned with chemical burns or other hazards while mixing the dye material **100**.

The dye material **100** is generally packaged in fluid-resistant bottles **150**, drums or other similar containers in a variety of sizes. As shown by the transportation truck in FIG. 3, the packaged dye material **100** can be easily stored for extended periods of time as the dye material **100** has an unlimited shelf life. A perceived benefit of the powder dye material **100** is an improved efficiency in the industry through the extended life of the dye material **100**. Past aqueous dye materials have a definite shelf-life allowing for waste in the industry.

Also shown in Figure is the effect of how the compact packaging of the powder dye material **100** allows for lighter, more efficient storage and shipping arrangements. Past dye materials have been cumbersome and weighty, as these materials include a hazardous aqueous solution. The present invention provides the powder dye material **100** for storage and shipping without the heavy aqueous element.

Prior to modification of a surface, dye material **100** must be provided **1200** and transported **1250** to the work site. As discussed, dye material **100** may be transported **1250** easily to a work site since it is non-hazardous and compact. Additionally, multiple dye colors may be easily transported **1250** to the work site to allow for the use of multiple dye colors on the application surface or to allow for mixing of colors. As an example, a yellow dye and a blue dye may be mixed to form a green dye. It is envisioned that a series of base colors may be used to form any desired color similar to the mixing of food dyes commonly found in recipes or paint colors commonly found in hardware stores.

Prior application to a surface, dye material **100** is mixed **1500** with aqueous material **500** in equal parts to create a dye composition **1000**. Upon mixing **1500** with the aqueous material, the hue and color of the dye material **100** may be modified by adding differing colored dyes and more aqueous material. The user may modify the intensity of the hue of the dye composition by mixing more aqueous material **500** than dye material **100**. the mixture of aqueous material **500** with the dye material **100** can be in small or large quantities based upon the anticipated use of the dye composition **1000**. Specifically, the user can chose the amount of dye material **100** to mix **1500** based upon the desired amount of dye composition **1000**. In another embodiment, a user may select to mix **1500** a multitude of sizes including one quart, one gallon, and five gallon increments for mixture with approximately 8-16 grams, 42-50 grams, and 226-234 grams by weight respectively.

The color of the dye material **100** can be tested by mixing a small amount, such as one gram of dye material **100** can be mixed **1500** with one milliliter of aqueous material **500** to create a small amount of dye composition **1000**. This small amount of dye composition **1000** can then later be applied **1530** to a concrete surface to create a sample surface for inspection. It is envisioned that a sample amount of dye composition **1000** may be packaged separate from the dye material **100** in a pre-mixed, ready-to-apply application. Additionally, this sample amount may be packaged in a aerosol sprayer for easy application. Further, an advantage of the present invention is that small amounts of dye material

5

100 can be mixed **1500** for application to a portion of the work surface. In this manner, users can treat **1530** a portion of the work surface at one time allowing for greater flexibility in working and providing for adaptations necessary for the particular jobsite. The mixed dye composition **1000** will be fairly consistent with each mixed batch as the composition is contemporaneously mixed **1500** with a consistent ratio of dye material **100** and aqueous material **500**.

Additional chemicals **505**, such as a drying agent like butyl cellosolve, can be added **1505** to the mixed dye composition **1000** for some surface applications, such as for sealed concrete. These additional chemicals **505** can be used to create a variety of effects, such as a mottled effect. In an embodiment having additional chemicals, the amount of aqueous material **500** added to the dye material **100** is decreased by half and the additional chemicals are added in an amount equal to the amount of aqueous material **500**.

After mixing **1500** the dye material **100** to form the dye composition **1000**, the dye composition **1000** should be agitated or shaken **1510** to encourage absorption of the dye material **100** by the aqueous material **500**. The dye composition **1000** should be allowed to dissolved for approximately three hours prior to application. The dye composition **1000** should be agitated again **1520** prior to use to ensure adequate distribution of dye material **100** throughout the composition.

Dye composition **1000** can be applied **1530** to a variety of concrete surfaces after mixing. As will be appreciated by one in the art, concrete surfaces present a variety of finishes. Dye material **100** is suitable for use in a variety of concrete surfaces. These finishes include smooth finishes, polished finishes, splattered finishes, rough-floated finishes, broomed

6

finishes, grooved finishes, stamped finishes, rubbed finishes, hammered aggregate finishes, exposed-stone finishes, and coarse-aggregate finishes. A benefit of the present invention is that the dye material **100** absorbs easily into the variety of possible surface finishes for concrete.

The invention has been described with reference to various specific and preferred embodiments and techniques. It will be understood, however, that reasonable modifications of such embodiments and techniques can be made while remaining within the spirit and scope of the invention.

From the foregoing, it will be seen that this invention well adapted to obtain all the ends and objects herein set forth, together with other advantages which are inherent to the structure. It will also be understood that certain features and subcombinations are of utility and may be employed without reference to other features and subcombinations. This is contemplated by and is within the scope of the claims. Many possible embodiments may be made of the invention without departing from the scope thereof. Therefore, it is to be understood that all matter herein set forth or shown in the accompanying drawings is to be interpreted as illustrated and not in a limiting sense.

What is claimed is:

1. A two part composition for coloring and polishing concrete surfaces consisting essentially of:
 - (a) a first part composition consisting of a dry, particulate mixture of azo and phthalocyanine dyes in a storage container;
 - (b) a second part composition consisting of a solvent mixture of water, acetone and butyl cellosolve; wherein said two part composition is mixed at a site of use.

* * * * *