

US009782026B2

(12) **United States Patent**  
**Cohan**

(10) **Patent No.:** **US 9,782,026 B2**  
(45) **Date of Patent:** **Oct. 10, 2017**

(54) **HIP APPARATUS**

(71) Applicant: **Macapak, Inc.**, Highland Park, IL (US)

(72) Inventor: **Adam K. Cohan**, Highland Park, IL (US)

(73) Assignee: **Macapak, Inc.**, Highland Park, IL (US)

(\*) Notice: Subject to any disclaimer, the term of this patent is extended or adjusted under 35 U.S.C. 154(b) by 0 days.

(21) Appl. No.: **14/247,997**

(22) Filed: **Apr. 8, 2014**

(65) **Prior Publication Data**

US 2014/0298575 A1 Oct. 9, 2014

**Related U.S. Application Data**

(60) Provisional application No. 61/809,799, filed on Apr. 8, 2013.

(51) **Int. Cl.**

**A47G 9/10** (2006.01)

**A41D 1/20** (2006.01)

**A41C 1/10** (2006.01)

(52) **U.S. Cl.**

CPC ..... **A47G 9/1045** (2013.01); **A41C 1/10** (2013.01); **A41D 1/20** (2013.01)

(58) **Field of Classification Search**

CPC ..... **A41D 13/0531; A41D 13/0506; A41D 13/0543; A41D 13/06; A41D 1/20; A47G 9/10451; A47G 9/1072; A47G 9/1081; A41C 1/10**

USPC ..... **5/631, 634, 601, 611, 624; 2/22, 467, 2/69, 76, 458**

See application file for complete search history.

(56) **References Cited**

U.S. PATENT DOCUMENTS

2,446,006	A *	7/1948	Hendricks .....	A47C 7/021	2/22
3,170,163	A *	2/1965	Mitchell .....	A41D 13/015	2/113
3,295,517	A *	1/1967	Stevens .....	A61F 5/0104	2/22
3,776,540	A *	12/1973	Comando .....	A61F 5/3715	128/882
4,065,814	A *	1/1978	Fox .....	A41D 13/02	2/227
4,177,806	A *	12/1979	Griffin .....	A61F 13/062	128/892
4,805,605	A *	2/1989	Glassman .....	A61F 5/0193	128/882
4,910,802	A *	3/1990	Malloy .....	A41D 13/0015	2/227
4,910,818	A *	3/1990	Grabill .....	A47C 20/021	297/423.17
5,109,546	A *	5/1992	Dicker .....	A41D 13/0015	2/227
5,201,074	A *	4/1993	Dicker .....	A41D 13/0015	2/227
5,308,305	A *	5/1994	Romney .....	A63B 21/4025	2/69

(Continued)

*Primary Examiner* — Shaun R Hurley

*Assistant Examiner* — Bao-Thieu L Nguyen

(74) *Attorney, Agent, or Firm* — Michael J. Femal; Much Shelist P.C.

(57) **ABSTRACT**

An apparatus and system for designed for supporting a hip of a pregnant woman who often experiences hip pain associated with her pregnancy to help relieve this pain including a leggings with hook-and-loop belts, straps and strips associated with pillows for the thigh and ankles.

**20 Claims, 5 Drawing Sheets**

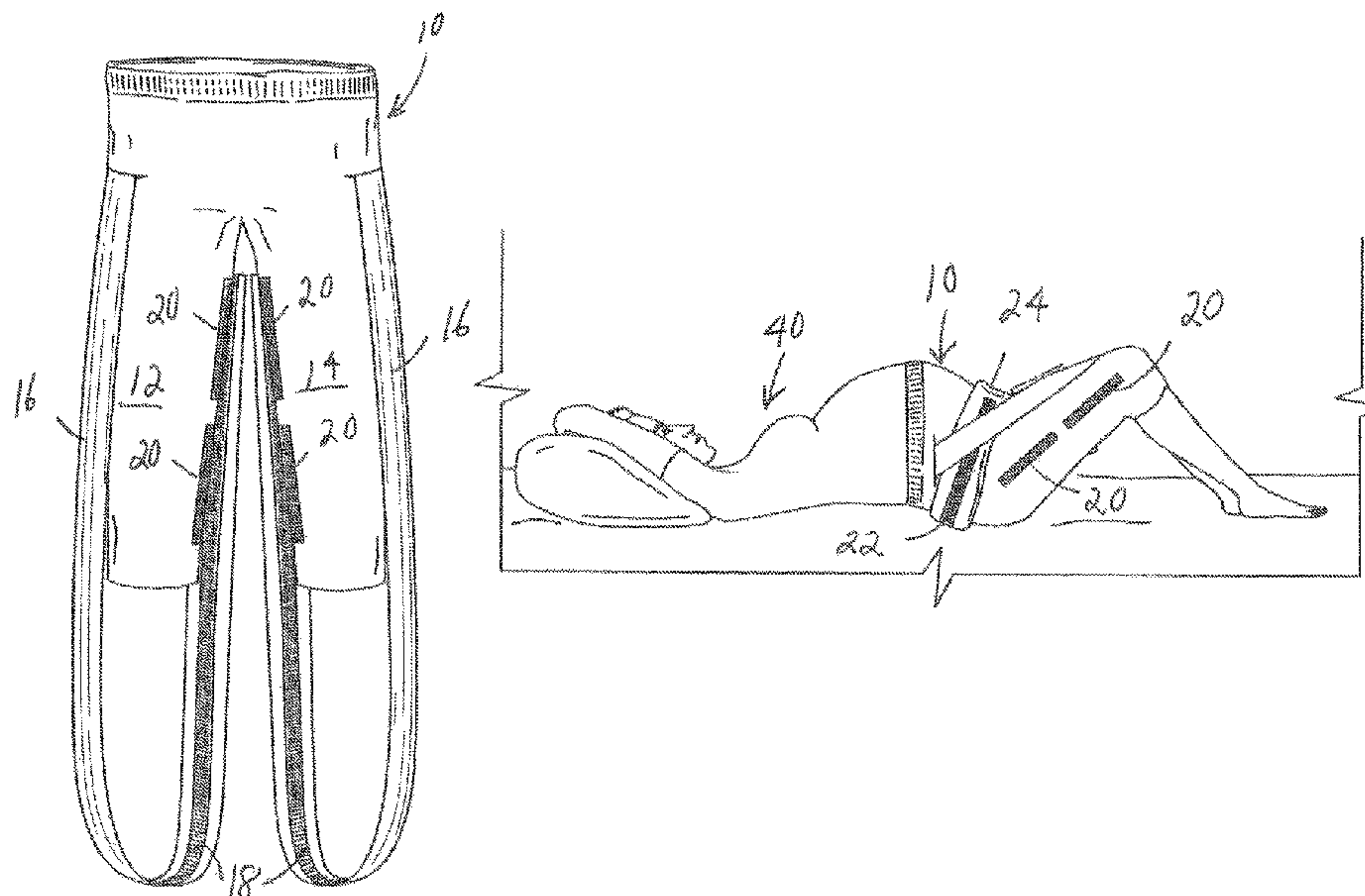

(56)

References Cited

U.S. PATENT DOCUMENTS

5,423,164	A *	6/1995	Schneider	.....	A41D 1/086	54/44.1	8,535,256	B2 *	9/2013	Taylor	.....	A61F 13/06	2/69
5,664,271	A *	9/1997	Bellavance	.....	A47C 20/025	5/630	8,544,114	B2 *	10/2013	Williams	.....	A41D 13/0015	2/227
5,737,773	A *	4/1998	Dicker	.....	A41D 13/0015	2/115	9,050,179	B2 *	6/2015	Brown	.....	A61F 5/0104	
5,901,531	A *	5/1999	Rogers	.....	B68C 1/00	54/44.1	9,314,363	B2 *	4/2016	Ingimundarson	.....	A61F 5/0102	
5,983,407	A *	11/1999	McKay	.....	A41D 13/0531	2/231	9,339,065	B2 *	5/2016	Willis	.....	A41D 1/06	
6,182,311	B1 *	2/2001	Buchanan	.....	A47C 20/021	128/845	9,414,954	B2 *	8/2016	Brown	.....	A61F 5/0104	
6,611,964	B2 *	9/2003	Lipsett	.....	A41D 1/06	2/227	2001/0002491	A1 *	6/2001	Ehr	.....	A41D 13/06	2/23
6,625,829	B2 *	9/2003	Zell	.....	A47C 7/383	128/DIG. 23	2001/0004771	A1 *	6/2001	Chou	.....	A41D 1/007	2/227
6,651,258	B2 *	11/2003	Pelensky	.....	A41D 11/00	2/227	2002/0188999	A1 *	12/2002	Haar	.....	A42B 3/0406	2/69
6,684,410	B2 *	2/2004	Robinett	.....	A41D 13/0015	2/228	2003/0046767	A1 *	3/2003	Roston	.....	A47C 20/021	5/648
6,767,603	B1 *	7/2004	Hurst	.....	A41D 13/008	2/69	2004/0172761	A1 *	9/2004	Druery	.....	A47C 20/021	5/650
6,795,975	B2 *	9/2004	Marmaropoulos	.....	H01Q 1/273	2/69	2008/0092265	A1 *	4/2008	Gage	.....	A41D 27/10	2/69
6,807,697	B2 *	10/2004	Druery	.....	A47C 20/021	5/640	2008/0282440	A1 *	11/2008	Larson	.....	F41H 3/02	2/69
6,922,860	B2 *	8/2005	Cuddy	.....	A47C 20/026	5/632	2009/0070910	A1 *	3/2009	McNally	.....	A41D 13/04	2/23
7,022,096	B1 *	4/2006	Alfieri	.....	A63B 71/1225	602/23	2010/0095422	A1 *	4/2010	Lopez	.....	A41D 13/065	2/23
7,086,091	B2 *	8/2006	Jordan	.....	A41D 13/0007	2/69	2010/0107299	A1 *	5/2010	Ota	.....	A41D 13/0015	2/69
7,194,770	B1 *	3/2007	Fecencko	.....	A41D 1/06	2/227	2011/0302685	A1 *	12/2011	Fay, III	.....	A62B 35/0012	2/69
7,536,736	B1 *	5/2009	Martinez	.....	A47G 9/0253	5/421	2012/0041488	A1 *	2/2012	Al Mubayadh	.....	A61F 5/01	606/237
7,584,516	B1 *	9/2009	Sneed	.....	A47C 20/025	2/23	2013/0047342	A1 *	2/2013	Schwingendorf	.....	A61F 5/3707	5/652
7,841,020	B2 *	11/2010	Mayfield	.....	A41D 13/02	2/227	2013/0067628	A1 *	3/2013	Harb	.....	A63B 21/0004	2/69
8,007,457	B2 *	8/2011	Taylor	.....	A61F 5/0102	2/69	2013/0074269	A1 *	3/2013	Phillips, II	.....	A47C 20/021	5/648
8,074,310	B1 *	12/2011	Robbins	.....	A47C 20/025	5/631	2013/0081206	A1 *	4/2013	Ginsberg	.....	A61G 13/10	5/623
8,156,941	B1 *	4/2012	Simms	.....	A47C 20/021	128/845	2013/0174325	A1 *	7/2013	Yang	.....	A41B 11/005	2/239
8,214,926	B2 *	7/2012	Brown	.....	A61F 5/0104	2/228	2014/0230116	A1 *	8/2014	Weber	.....	A41D 13/0543	2/22
							2015/0143621	A1 *	5/2015	Conolly	.....	A63B 21/4025	2/467
							2015/0297938	A1 *	10/2015	Dyer	.....	A63B 21/0557	2/160
							2015/0327689	A1 *	11/2015	Howard	.....	A47D 5/00	5/655

\* cited by examiner



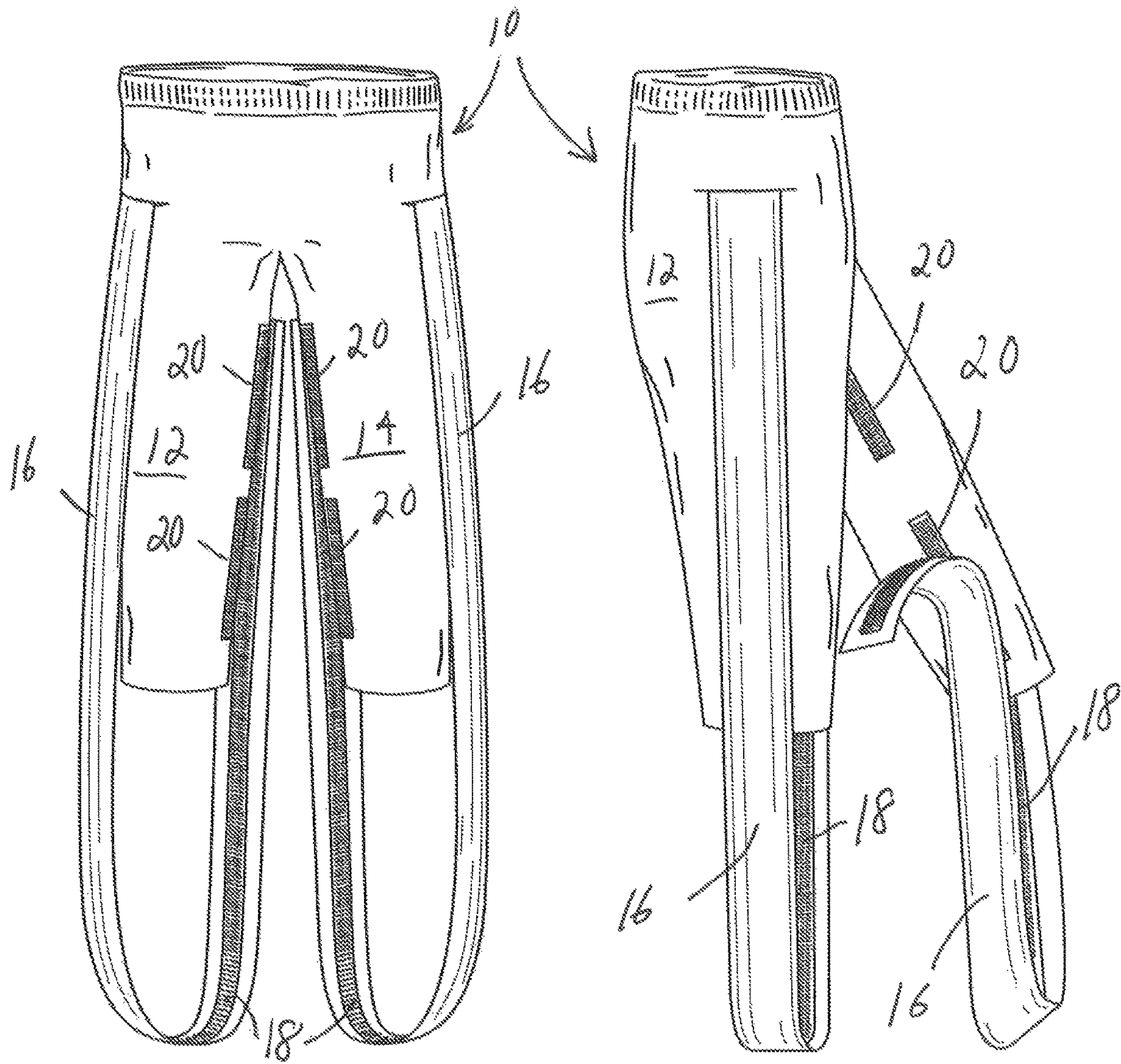

FIG. 1

FIG. 2

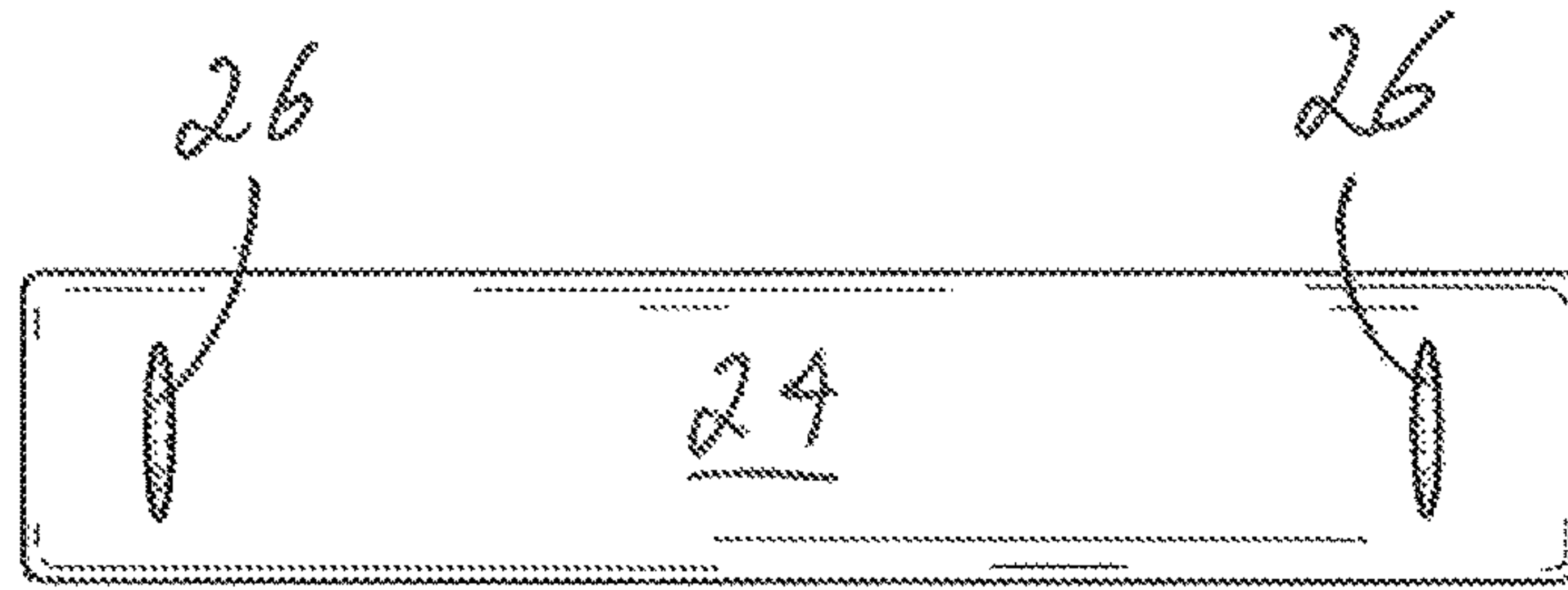

FIG. 3

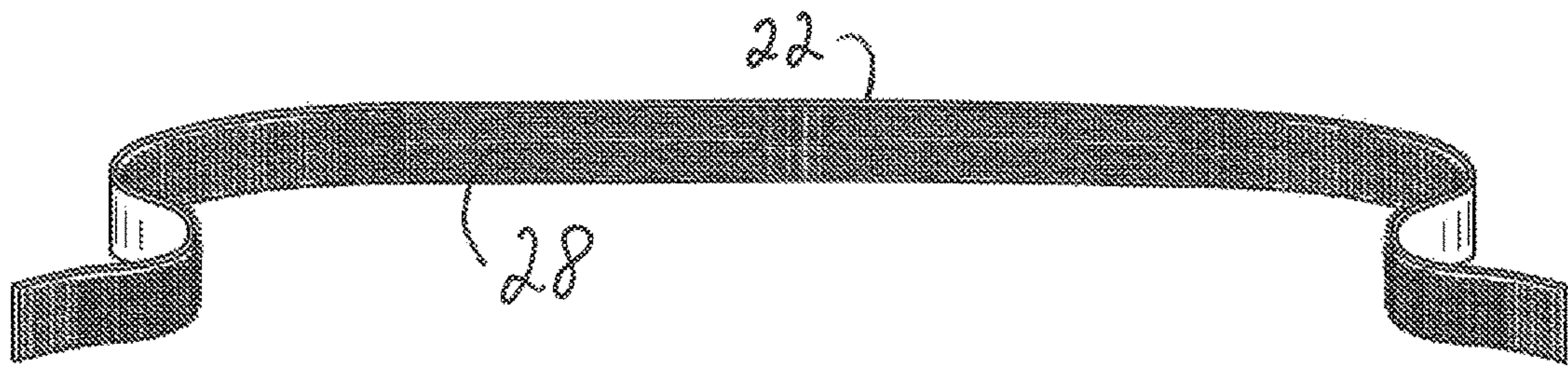

FIG. 4

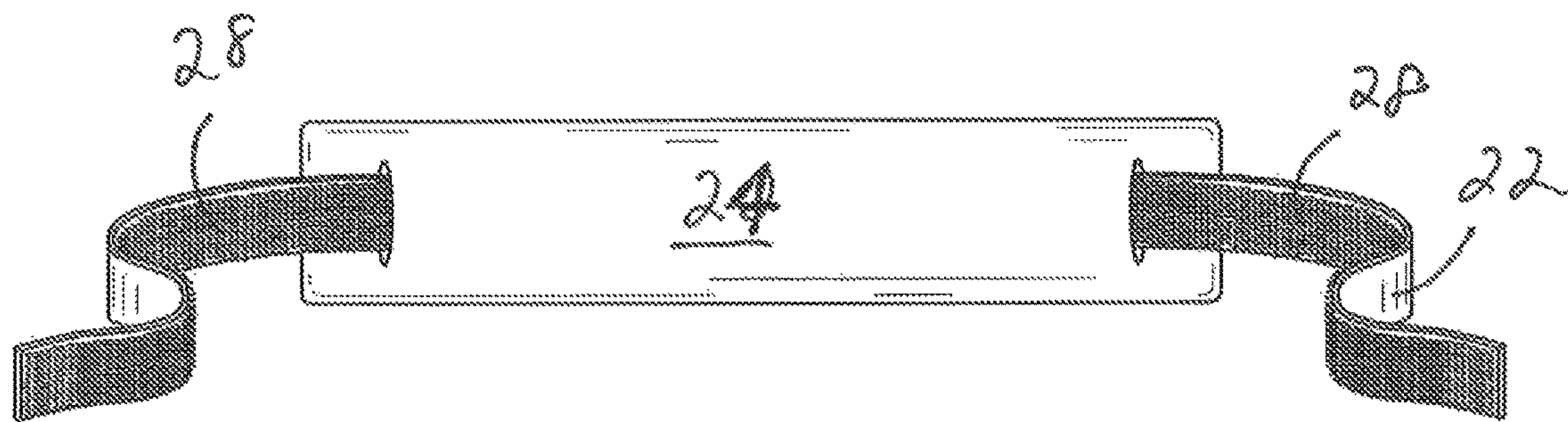

FIG. 5



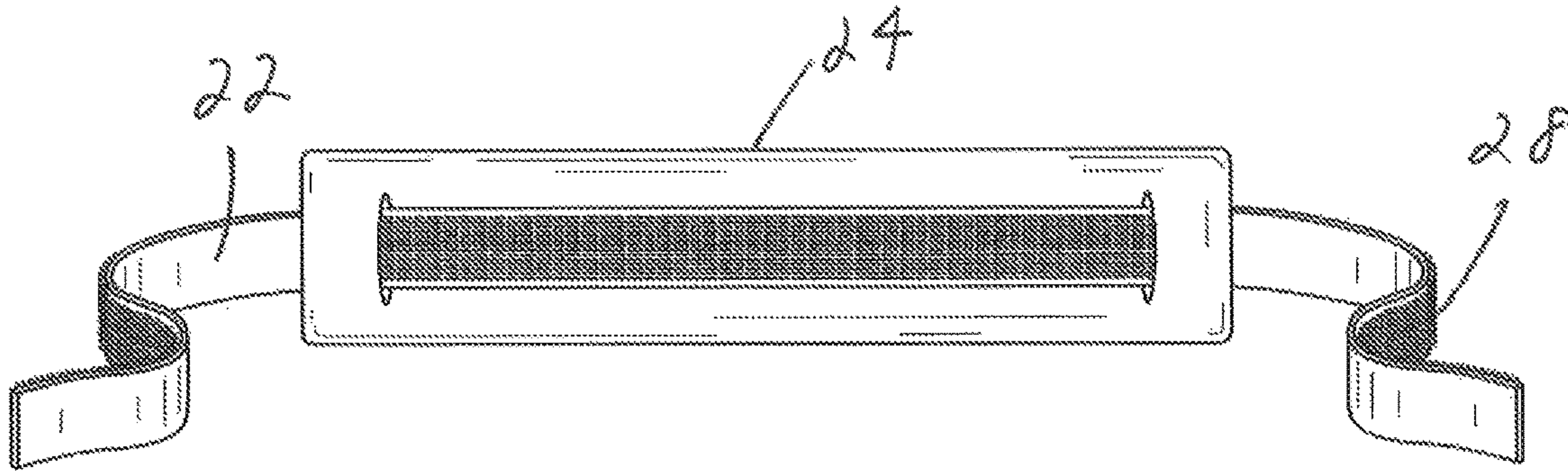

FIG. 6

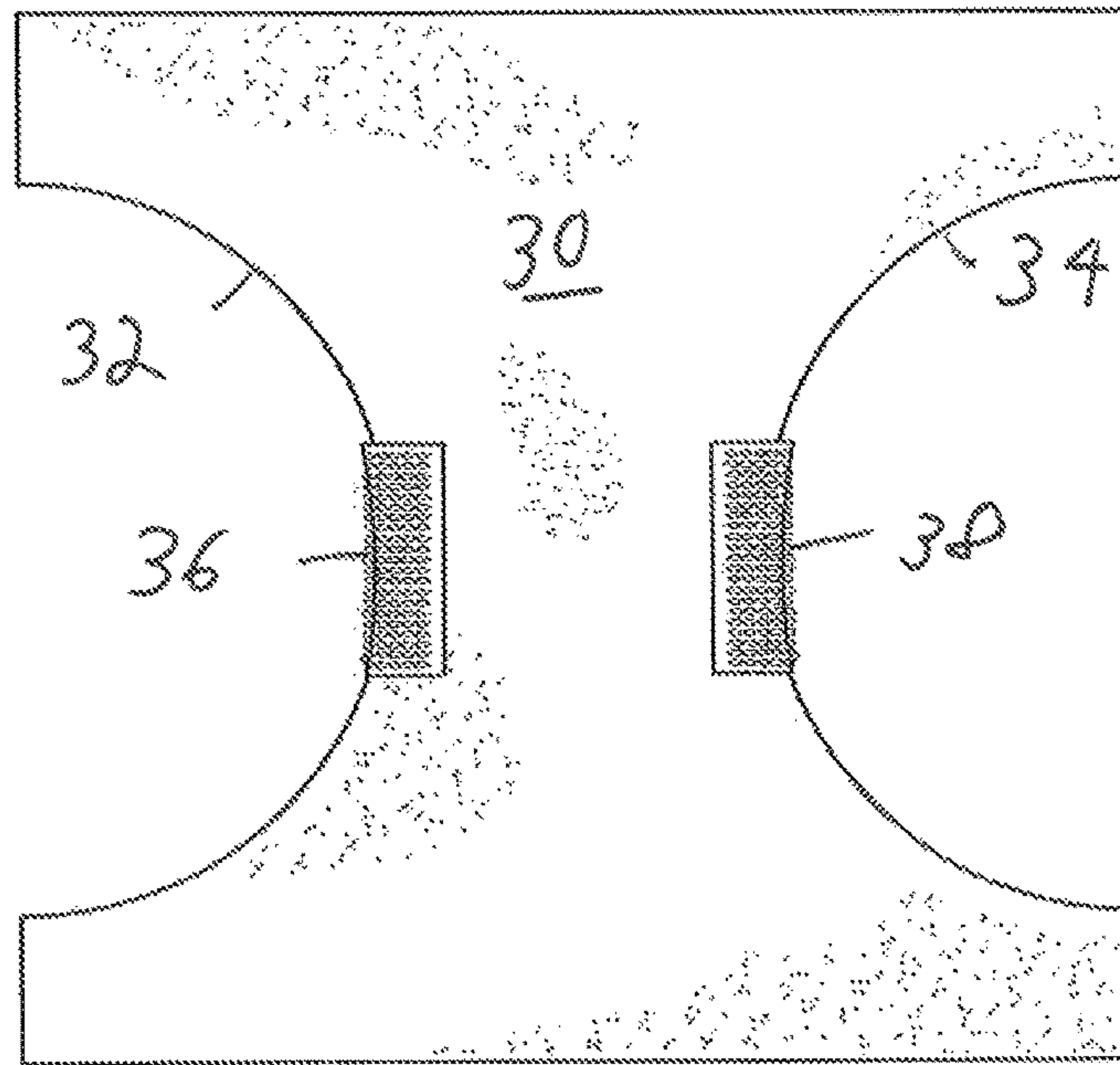
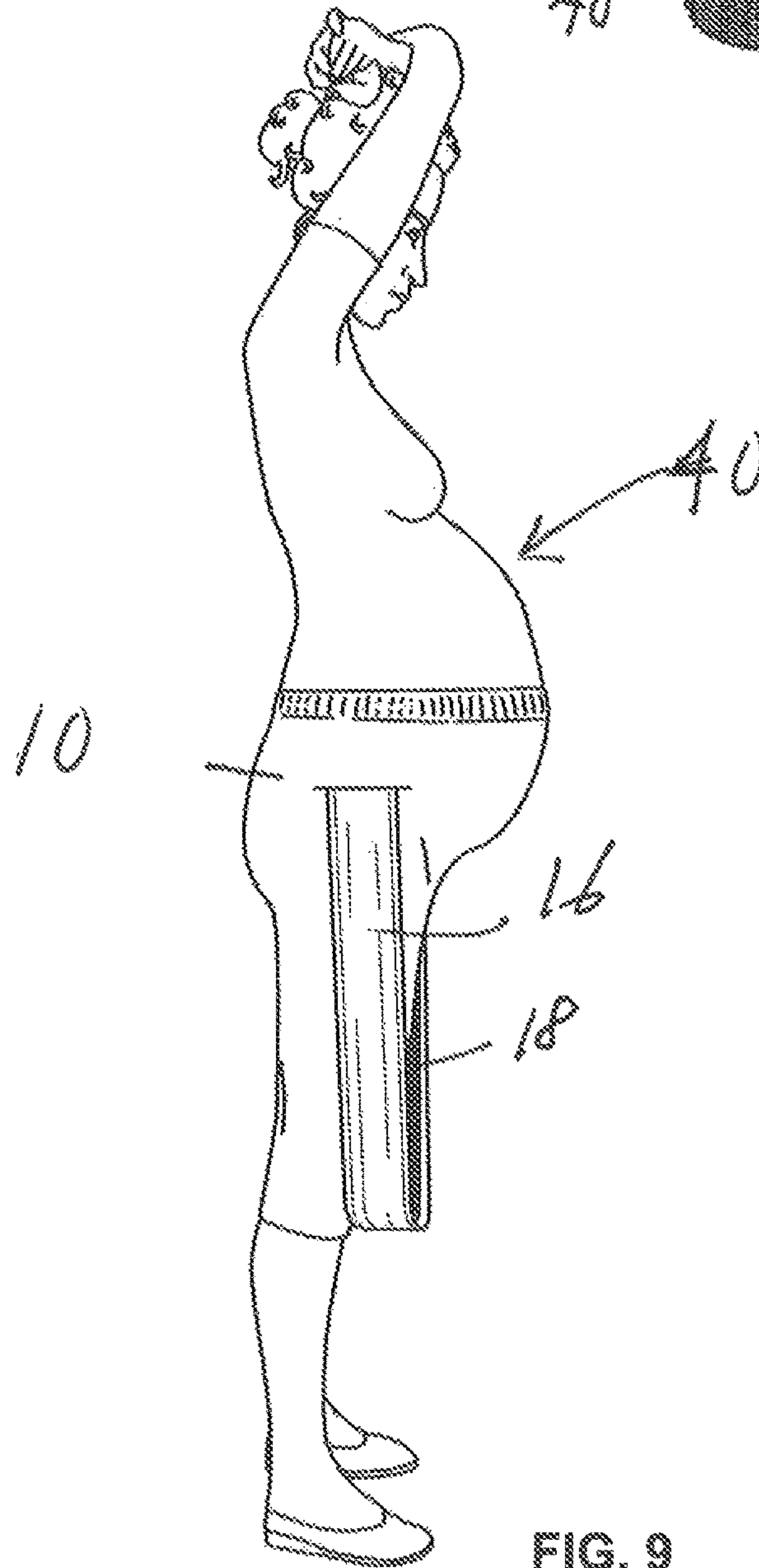
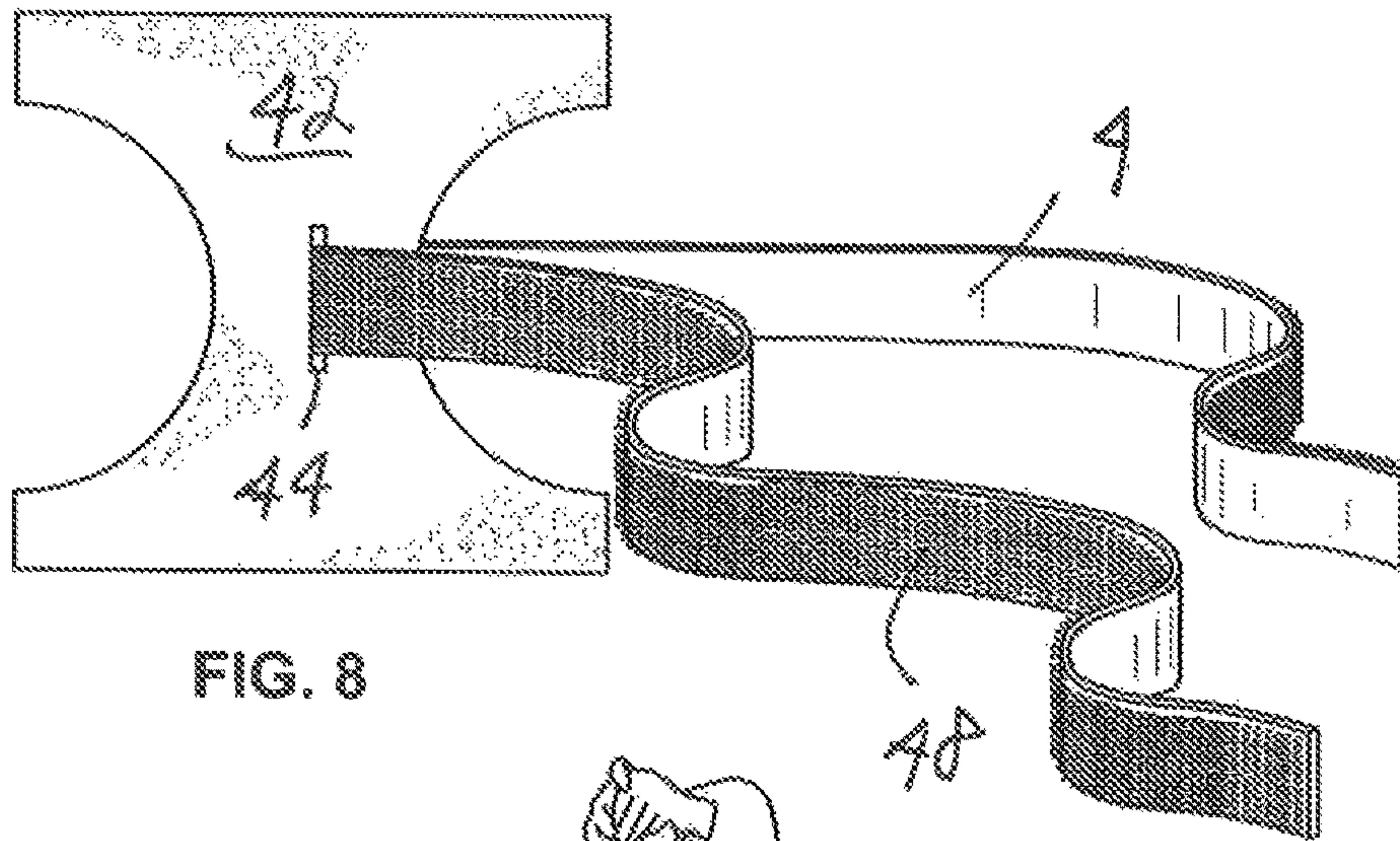

FIG. 7



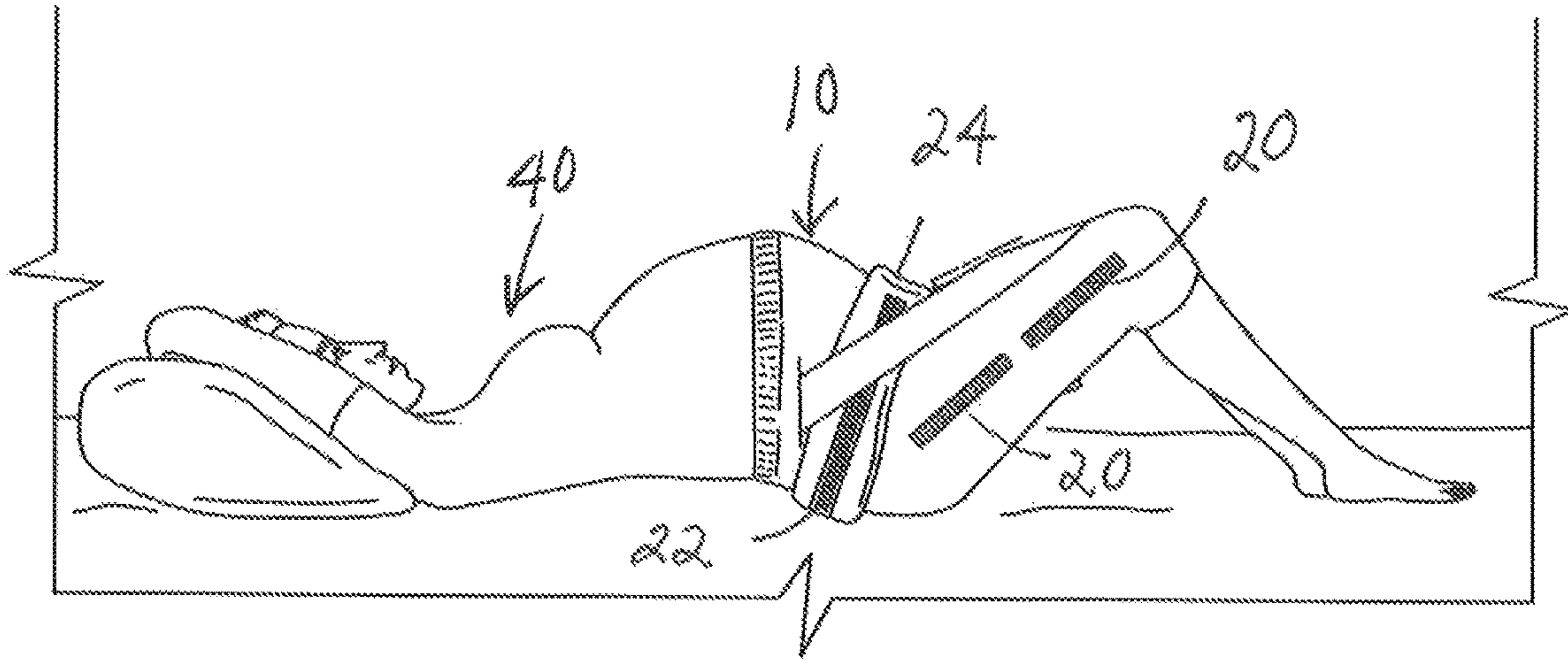

FIG. 10

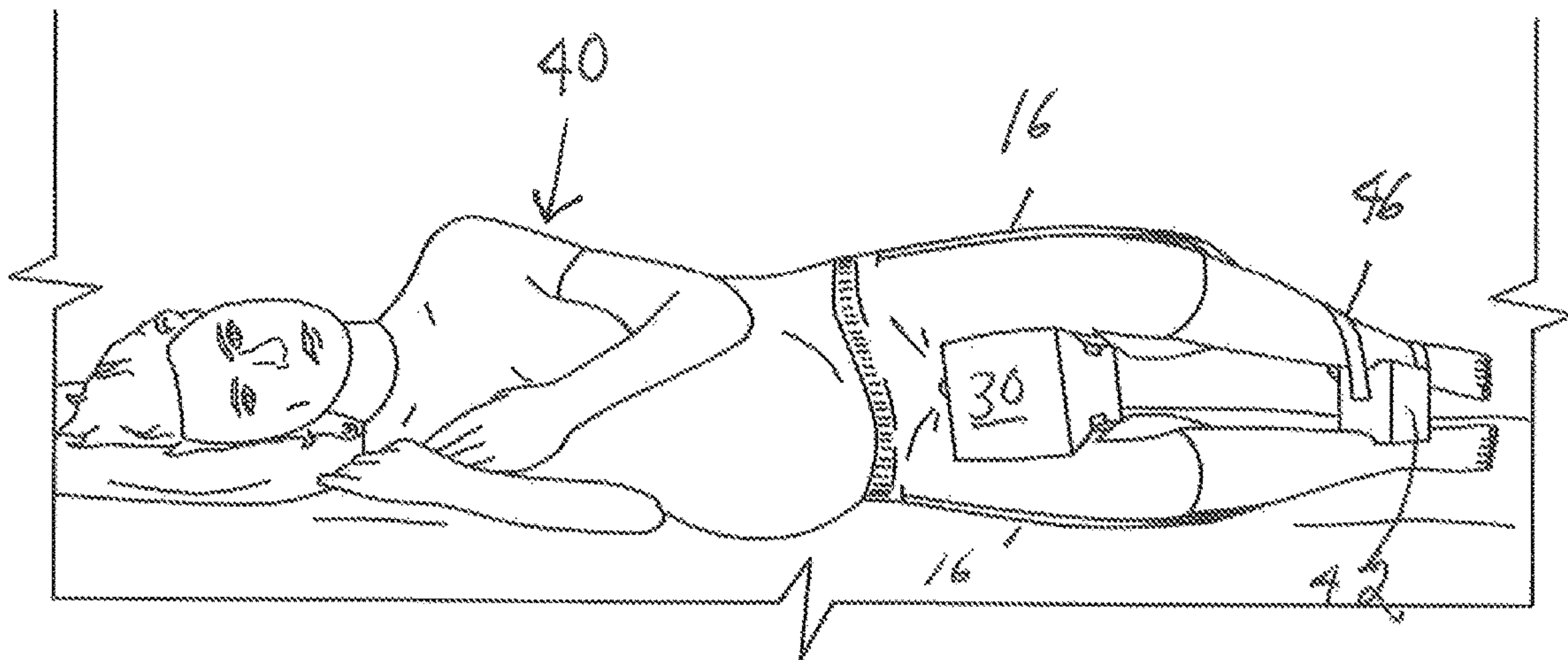

FIG. 11



**1****HIP APPARATUS****CROSS-REFERENCES TO RELATED APPLICATION**

The application claims priority to U.S. Provisional Patent Application No. 61/809,799 filed Apr. 8, 2013, entitled "Hip Apparatus", the entire contents of which is incorporated herein by this reference.

**FIELD OF INVENTION**

The present invention relates to an apparatus for supporting a woman's hip and, more particularly, an apparatus designed to support the hip of a pregnant woman who often experiences hip pain associated with her pregnancy to help relieve this pain.

**BACKGROUND OF THE INVENTION**

It is well known that abdominal distention due to excess weight causes pain. Though not limited to pregnancy, abdominal distention is especially encountered during pregnancy. In this respect, it is known that there is substantial weight gain during pregnancy, especially during the latter 20 gestational weeks. Weight increase during pregnancy may often reach 40 pounds or more with the largest amount of the increase occurring during the last 20 gestational weeks.

It is also well known that during pregnancy, the joints, ligaments and muscle structure of the pelvis and spine are particularly lax to increase the joint laxity and elasticity to accommodate the shape of the fetus.

Hip and pelvic pain is a very common ailment for both men and women. However, these symptoms are usually worse during a pregnancy. There are several reasons for the hip pain symptoms to be worse during a pregnancy. One reason is that during pregnancy the body of a woman releases a hormone called Relaxin. This hormone relaxes and softens joints and muscle tissue to accommodate the baby moving through the birth canal during delivery.

Unfortunately, this hormone can also increase the risk for joint injury and can cause hip pain during pregnancy. Second, as the pregnancy progresses, the uterus becomes larger. As previously stated above, pregnant women also gain weight. The added pressure on the pelvis from the gravid uterus with an unborn fetus developing inside of it and weight gain can aggravate hip and pelvic pain. Lastly, a pregnant woman is instructed to sleep on her side with the left side being more optimal than the right side. This recommendation is usually given after 20 weeks gestation. This positioning helps to optimize placental perfusion with the least amount of stress on the mother's cardiovascular system. However, sleeping in this position causes added strain on the hips and thus leading to more hip pain.

Unfortunately, treatment options for the hip pain are limited due to safety restrictions in pregnancy. There are some treatment recommendations to counter this hip and pelvic pain as listed below but usually these steps supply minimal to moderate relief:

- 1) Bending legs, not crossing the legs while sleeping
- 2) Body pillows
- 3) Heating pads
- 4) Proper mattresses
- 5) Hip exercises and stretches
- 6) Swimming/water aerobics
- 7) Yoga/Pilates
- 8) Perinatal massages

**2**

- 9) Maternity belt iliac brace used when woken up & about—not for sleeping
- 10) BELLA BANDS®
- 11) Analgesics such as TYLENOL®
- 12) Sitz baths

Therefore, what is really needed to help alleviate the hip pain is added support across the joint to counter the reasons listed above. This is exactly what the apparatus of the present invention accomplishes. The apparatus of the present invention securely holds the ball in the socket of the hip joint while sleeping and therefore lessens the strain across the joint and thus lessens the possible hip pain during a woman's pregnancy.

**SUMMARY OF THE INVENTION**

The apparatus of the present invention incorporates a unique design to women leggings. The leggings may be made from stretch cotton, a modal fabric that resists pilling and still holds its shape for extended wear during pregnancy. The leggings may have a comfortable midrise to go with a slim elastic waistband that offers an easy fit for pregnant women that generally is ankle-length but the leggings may be shorter or longer in length depending upon the circumstances. So the leggings may be made from a mix of cotton, modal, and small percentage of SPANDEX®. Of course other materials like polyester, rayon and nylon or any combination thereof that is normally used for clothing leggings is a fine material too. Also, leather or rubberized leggings might also be material suitable for the hip support hip apparatus.

So the general stretch cotton leggings of various sizes and colors include fabric hook-and-loop fastener sewn along the inner and outer leg of the leggings or approximately in opposing position with respect to one another.

A belt with fabric hook-and-loop fastener sewn along the inside and outside is also a component part of the apparatus used in combination with the leggings to provide the structure that helps to alleviate hip pain when attached in a number of different ways. A back pillow comprised of a generally foam material inside with a cloth material on the outside includes openings generally at either end of the pillow cloth enclosure thereof to allow the VELCRO® belt to slip through the openings to use the pillow as a cushioned support when engaging the back of a pregnant lady using the support apparatus.

An alternate structure is where 1) the padding is now sewn into the pants; 2) the leg straps of fabric hook-and-loop fastener are sewn into the padding and exit from a slit on the outside of the legs; and 3) the strap is 2 inches thick with a fabric hook-and-loop fastener along the length.

Therefore, the present invention comprises generally cotton leggings of various sizes and colors with Velcro straps sewn along the inner and outer leg of the leggings, a belt with a fabric hook-and-loop fastener sewn along the inside and outside surfaces of the belt, a back support pillow including a foam core and cloth exterior pillow case includes openings at opposite ends of the pillow case enclosing the foam core wherein the openings in the pillow case receive the belt there through to have the pillow slide onto the belt with opposing ends of a predetermined length of the belt with fabric hook-and-loop fastener hang out of the pillow case to engage the fabric hook-and-loop fastener straps along the inner and/or outer leg of the leggings, a foam thigh support pillow with a fabric hook-and-loop fastener attached thereto for fastening to the belt or to the inner fabric hook-and-loop fastener strap sewn on the inner leg of the



3

legging, and a foam ankle support pillow with a fabric hook-and-loop fastener strap to keep the pillow in place between the ankles on the pregnant woman.

## DRAWINGS

FIG. 1 shows a front view of leggings made in accordance with the present invention;

FIG. 2 shows a side view of the leggings of FIG. 1;

FIG. 3 show a frontal view of a foam core pillow enclosed by a cloth pillow case having openings at opposing ends in accordance with the present invention;

FIG. 4 shows a cloth belt having predetermined strips of fabric hook-and-loop fastener along its length.

FIG. 5 shows a front view of the cloth belt having a portion of the belt attached to a foam core back support pillow within a cloth pillow case in accordance with the present invention;

FIG. 6 shows a back view of a cloth belt attached to a foam core back support pillow within a cloth pillow case of FIG. 3;

FIG. 7 shows a side view of a foam thigh support pillow in accordance with the present invention having fabric hook-and-loop fastener in the concave portion thereof;

FIG. 8 shows a side view of a foam ankle support pillow with a fastening strap;

FIG. 9 shows a side view of the leggings on a person in accordance with the present invention;

FIG. 10 shows the support pillow around the waist and one end of the belt attached to the outside fabric hook-and-loop fastener on the leg of the legging in accordance with the present invention; and

FIG. 11 shows both the thigh and ankle from pillows of FIGS. 7 and 8, respectively.

## DETAILED DESCRIPTION OF THE INVENTION

As shown in FIGS. 1 and 2, a hip apparatus or system made in accordance with the present invention comprises a leggings 10 having two legs 12 and 14 with a strap 16 having fabric hook-and-loop fastener 18 on at least one side over generally the length of the exposed strap 16. As shown in FIGS. 1 and 2, one end of the strap 16 is sewn into the upper portion of the leggings or garment 10. Also, the leggings or garment includes a hook-and-loop strips 20 or the like running down the inside and outside of each leg 12 and 14 a predetermined distance for attachment to the hook-and-loop fastener 18 on the strap 16 or to a belt 22 hanging down from either end of a back support pillow 24 as shown in FIGS. 3, 5, 6 and 10 with a pair of openings 26 on generally opposing ends of the pillow 24 for receiving the belt 22 with a hook-and-loop fastener 28 running generally the length of the belt 22 for attaching to the hook-and-loop fastener 28 to the hook-and-loop fasteners 20 on the outside of the legs 12 and 14, respectively. The pillow 24 is made of a foam block or any other suitable material that is generally solid or slightly flexible but generally holds its shape.

As shown in FIGS. 7 and 11, a thigh support pillow 30 of similar material to pillow 24 includes opposing concave portions 32 and 34, respectively, with opposing hook-and-loop fasteners 36 and 38 therein that is placed between the thighs of a pregnant woman 40 sleeping on her left side is further attached to either the belt 22 or to the fasteners 20 on inside of the each leg 12 and 14 of the leggings 10.

As shown in FIGS. 8 and 11, an ankle support pillow 42 having an opening 44 therethrough for receiving a belt 46

4

through the opening 44 and having a hook-and-loop fastener 48 generally running the length of the belt 46 is placed between the ankles of a pregnant woman 40 and the fabric hook- and loop fastener 48 or the like to hold the pillow 42 in place between the ankles.

The combination of the leggings 10 of various sizes and colors, hook-and-loop fabric straps or belts 16 sewn into leggings and extending through the pillow 24 within the leggings 10 and having the inner and outer length of each leg 12 and 14 over a predetermined distance with hook-and-loop strips 20 to engage the hook-and-loop fasteners 18 of the belts 16 provide a back support for the pregnant woman 40.

The back support pillow 24 with the opposing openings 26 at either longitudinal end thereof allowing the belt 22 to slide through the openings 26 and then hang down a predetermined distance from either side of the pillow 24 to engage the hook-and-loops strips 20 on the outside of each leg 12 and 14, the thigh support pillow 30 attaching to the inner side of each leg on the leggings 10 and the ankle support pillow 42 attached via hook- and loop strap 46 attached thereto or other fastener are all elements comprising the overall apparatus and system for relieving hip pain in the pregnant women 40 while trying to sleep.

Although the invention has been shown and described with reference to a specific structural embodiment, it is understood certain elements are widely variable in composition of materials and design and that the materials shown do not limit the field of practical application or the substitution of similar materials to achieve the same result. Therefore many modifications and changes are possible without deviation from the scope of the attached patent claims.

What is claimed is:

1. A hip support apparatus and system configured to relieve hip pain during a pregnancy when sleeping in a fetal position on the side, comprising:

an elastic legging with a midrise having an elastic waistband and two legs of a predetermined length, said legs having hook-and-loop fasteners running a predetermined length on the inside of each leg;

a pair of opposing legging straps having hook-and-loop fasteners running a predetermined length on one side of each strap and each leg strap attached to the outside of each legging at generally the midrise of a predetermined length running on the outside length of each legging and then looping back to the inside of each leg of a predetermined length;

a back support pillow having a belt with a hook-and-loop fastener on one side of the belt connected to the back support pillow and the support pillow held in place to provide a support to a hip joint during the pregnancy by the hook-and-loop fasteners of the belt connected to the hook-and-loop fasteners of the leg straps to position the support pillow generally at or near the elastic waistband; and

a thigh support pillow having opposing hook-and-loop fasteners held in place by connection to the hook-and-loop fasteners on the inside of each leg;

whereby the legging straps are configured to go around the knee when sleeping in a fetal position on a womans' side to keep the hip ball in the hip socket to reduce the hip pain.

2. The hip support apparatus and system configured to relieve hip pain during a pregnancy of claim 1, wherein the back support pillow is made of foam block or any other suitable material that is generally solid or slightly flexible that holds its shape.



5

3. The hip support apparatus and system configured to relieve hip pain during a pregnancy of claim 1, wherein the leg straps are sewn into the leggings below the waistband.

4. The hip support apparatus and system configured to relieve hip pain during a pregnancy of claim 1, wherein the thigh support pillow is made of foam block or any other suitable material that is flexible and holds its shape.

5. The hip support apparatus and system configured to relieve hip pain during a pregnancy of claim 1, wherein the thigh support pillow includes concave portions wherein the hook-and-loop fasteners are located at the apex of each concave portion of the thigh support pillow.

6. The hip support apparatus and system configured to relieve hip pain during a pregnancy of claim 1, further comprising an ankle support pillow having concave opposing portions with an ankle strap connected to the ankle support pillow to hold the ankle support pillow in place.

7. A hip support apparatus and system configured to relieve hip joint pain during a pregnancy when a woman is lying on her side to sleep, comprising:

an elastic legging having a waist and two legs, each leg having hook-and-loop fasteners on the inside of each leg;

a pair of opposing legging straps attached at one end to the outside of the legging having hook-and-loop fasteners on one side of each strap, said straps configured to form a loop back to the inside of each leg to adjustably attach the other end of the leg straps to the hook-and-loop fastener on the inside of each leg to hold each hip joint in place to relief the pain when sleeping on a woman side during pregnancy;

a back support pillow;

a belt with a hook-and-loop fastener on one side of the belt connected to the back support pillow with the belt hook-and-loop fastener connected to the hook-and-loop fasteners of the leg straps to provide support to a hip joint during the pregnancy; and

a thigh support pillow having opposing hook-and-loop fasteners held in place by connection to the hook-and-loop fasteners on the inside of each leg.

8. The hip support apparatus and system configured to relieve hip joint pain during a pregnancy of claim 7, wherein the back support pillow includes opposing openings at either longitudinal end thereof allowing the belt to slide through the openings and then to engage the hook-and-loop fastener of the belt to the hook-and-loop fasteners of the leg straps for fixedly positioning the support pillow.

9. The hip support apparatus and system configured to relieve hip joint pain during a pregnancy of claim 7, wherein the leg straps are affixed to opposing sides of the legging below the waist.

10. The hip support apparatus and system configured to relieve hip joint pain during a pregnancy of claim 7, wherein the legging is made of a cotton and elastic material to expand in order to properly fit during a time span of the pregnancy.

11. The hip support apparatus and system configured to relieve hip joint pain during a pregnancy of claim 7, wherein the thigh support pillow includes a foam core and a cloth exterior pillow case.

12. The hip support apparatus and system configured to relieve hip joint pain during a pregnancy of claim 7, wherein the leg straps are approximately two inches wide and a predetermined length having one end sewn into opposing sides of the legging.

6

13. The hip support apparatus and system configured to relieve hip joint pain during a pregnancy of claim 7, wherein the legging is made of a polyester, rayon, nylon, elastic blend of similar materials or any combination thereof.

14. The hip support apparatus and system configured to relieve hip joint pain during a pregnancy of claim 7, wherein the back support pillow is generally a foam core with a cloth, material enclosure on the outside that includes openings generally at either end of the pillow cloth enclosure thereof to receive the belt for positioning the back pillow.

15. A hip support apparatus and system configured to relieve hip joint pain during a pregnancy, comprising:

a legging having a waist and two legs with hook-and-loop fasteners on the inside of each leg;

a pair of opposing legging straps attached at one end adjacent the waist of the legging having hook-and-loop fasteners on one side of each strap, said straps configured to form a loop to go around the knee of a woman lying on her side during pregnancy back to the inside of each leg to adjustably attach the other end of the leg straps to the hook-and-loop fastener on the inside of each leg;

a back support pillow having openings at either end of the back support pillow;

a belt with a hook-and-loop fastener on one side of the belt slid through the openings of the back support to connect the belt hook-and-loop fastener connected to the hook-and-loop fasteners of the leg straps to provide a support position to a hip joint during the pregnancy; and

a thigh support pillow having opposing hook-and-loop fasteners held in place by connection to the hook-and-loop fasteners on the inside of each leg;

whereby the legging straps are configured to go around the knee to hold the ball socket of a hip together during pregnancy.

16. The hip support apparatus and system configured to relieve hip joint pain during a pregnancy of claim 15, wherein the leggings are made of an elastic material that expands for a comfortable fit during all stages of pregnancy.

17. The hip support apparatus and system configured to relieve hip joint pain during a pregnancy of claim 15 wherein the hook-and-loop fasteners on the inside of the legs, on the legging straps, on the belt and on the thigh pillow provide multiple positioning of the back support pillow and thigh pillow to provide support for the hip joint to relieve the pain during a pregnancy.

18. The hip support apparatus and system configured to relieve hip joint pain during a pregnancy of claim 15 wherein the back support pillow and the thigh support pillow are made of a foam core with a cloth exterior pillow case.

19. The hip support apparatus and system configured to relieve hip joint pain during a pregnancy of claim 15, wherein the legging is generally ankle-length or configurable to a predetermined length.

20. The hip support apparatus and system configured to relieve hip joint pain during a pregnancy of claim 15, wherein the legging is made of an elastic cotton or similar material and wherein the legging straps are sewn into the opposing sides of the legging adjacent and below the waist.