



US009779887B2

(12) **United States Patent**
Pyzza et al.

(10) **Patent No.:** **US 9,779,887 B2**
(45) **Date of Patent:** **Oct. 3, 2017**

(54) **APPARATUS FOR ENCLOSING ENERGY STORAGE DEVICES**

(71) Applicant: **Ioxus, Inc.**, Oneonta, NY (US)

(72) Inventors: **Jake Pyzza**, Troy, NY (US); **Daniel Matthew Halbig**, Ballson Lake, NY (US)

(73) Assignee: **Ioxus, Inc.**, Oneonta, NY (US)

(*) Notice: Subject to any disclaimer, the term of this patent is extended or adjusted under 35 U.S.C. 154(b) by 210 days.

(21) Appl. No.: **14/597,844**

(22) Filed: **Jan. 15, 2015**

(65) **Prior Publication Data**

US 2016/0211086 A1 Jul. 21, 2016

(51) **Int. Cl.**

H05K 7/20 (2006.01)
H01G 11/82 (2013.01)
H01G 9/00 (2006.01)
H01G 9/08 (2006.01)
H01G 9/21 (2006.01)
H01G 11/08 (2013.01)
H01G 11/10 (2013.01)
H01G 11/76 (2013.01)
H01M 2/10 (2006.01)
H01M 10/653 (2014.01)

(52) **U.S. Cl.**

CPC **H01G 11/82** (2013.01); **H01G 9/0003** (2013.01); **H01G 9/08** (2013.01); **H01G 9/21** (2013.01); **H01G 11/08** (2013.01); **H01G 11/10** (2013.01); **H01G 11/76** (2013.01); **H01M 2/1016** (2013.01); **H01M 10/653** (2015.04); **Y02E 60/13** (2013.01)

(58) **Field of Classification Search**
CPC H01G 11/08; H01G 11/82; H01G 9/0003; H01G 9/08; H01G 9/21
See application file for complete search history.

(56) **References Cited**

U.S. PATENT DOCUMENTS

5,070,427 A 12/1991 Bush
5,510,208 A 4/1996 Hall et al.
6,087,038 A * 7/2000 Flament H01M 2/1072
429/120
6,811,921 B2 11/2004 Dansui et al.
7,180,726 B2 2/2007 Thrap
7,531,269 B2 5/2009 Wegner

(Continued)

FOREIGN PATENT DOCUMENTS

WO 2012043266 A1 4/2012

OTHER PUBLICATIONS

Patent Cooperation Treaty, International Search Report for PCT/US2016/013336 dated Mar. 17, 2016, 9 pages.

Primary Examiner — Yuriy Semenenko

(74) *Attorney, Agent, or Firm* — Matthew J. Kinnier; Hoffman Warnick LLC

(57) **ABSTRACT**

Embodiments of the present disclosure include an apparatus for enclosing energy storage devices. An apparatus according to the present disclosure can include: an elongated sleeve having a contoured interior configured to enclose each of a plurality of energy storage devices, wherein the elongated sleeve is composed at least partially of a thermally conductive material; and at least one slot disposed on an exterior surface of the elongated sleeve, wherein the at least one slot is configured to receive for mechanically coupling a mounting rail to the elongated sleeve.

20 Claims, 5 Drawing Sheets

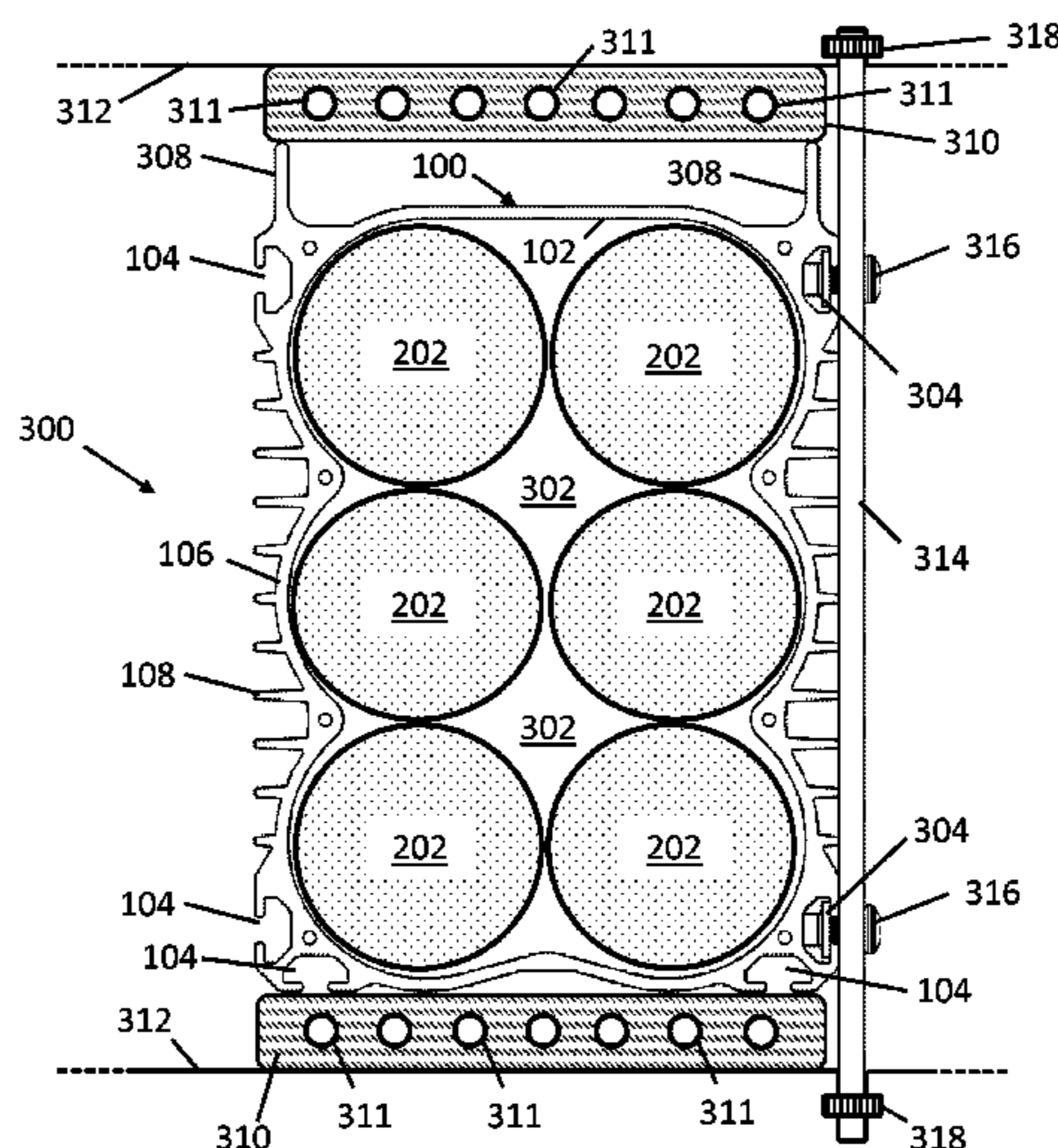

(56)

References Cited

U.S. PATENT DOCUMENTS

7,776,467	B2	8/2010	Kato et al.	
8,114,540	B2	2/2012	Trester et al.	
8,178,234	B2	5/2012	Fukuoka et al.	
2003/0059676	A1 *	3/2003	Ruiz Rodriguez	H01M 2/0242 429/164
2005/0079408	A1	4/2005	Hirano	
2005/0255379	A1	11/2005	Marchio et al.	
2006/0078789	A1 *	4/2006	Wegner	H01M 10/625 429/120
2007/0099073	A1	5/2007	White et al.	
2008/0318119	A1	12/2008	Watanabe et al.	
2009/0080126	A1	3/2009	Wilk et al.	
2009/0111015	A1 *	4/2009	Wood	H01M 2/1077 429/164
2009/0155680	A1	6/2009	Maguire et al.	
2010/0028764	A1	2/2010	Maier et al.	
2010/0247994	A1 *	9/2010	Park	H01M 2/105 429/96
2011/0177381	A1	7/2011	Oya et al.	
2012/0115016	A1	5/2012	Kim	
2013/0082520	A1	4/2013	Leemans et al.	
2013/0266826	A1	10/2013	Cowperthwaite et al.	
2013/0316203	A1 *	11/2013	Hsiao	H01M 10/5004 429/83

* cited by examiner

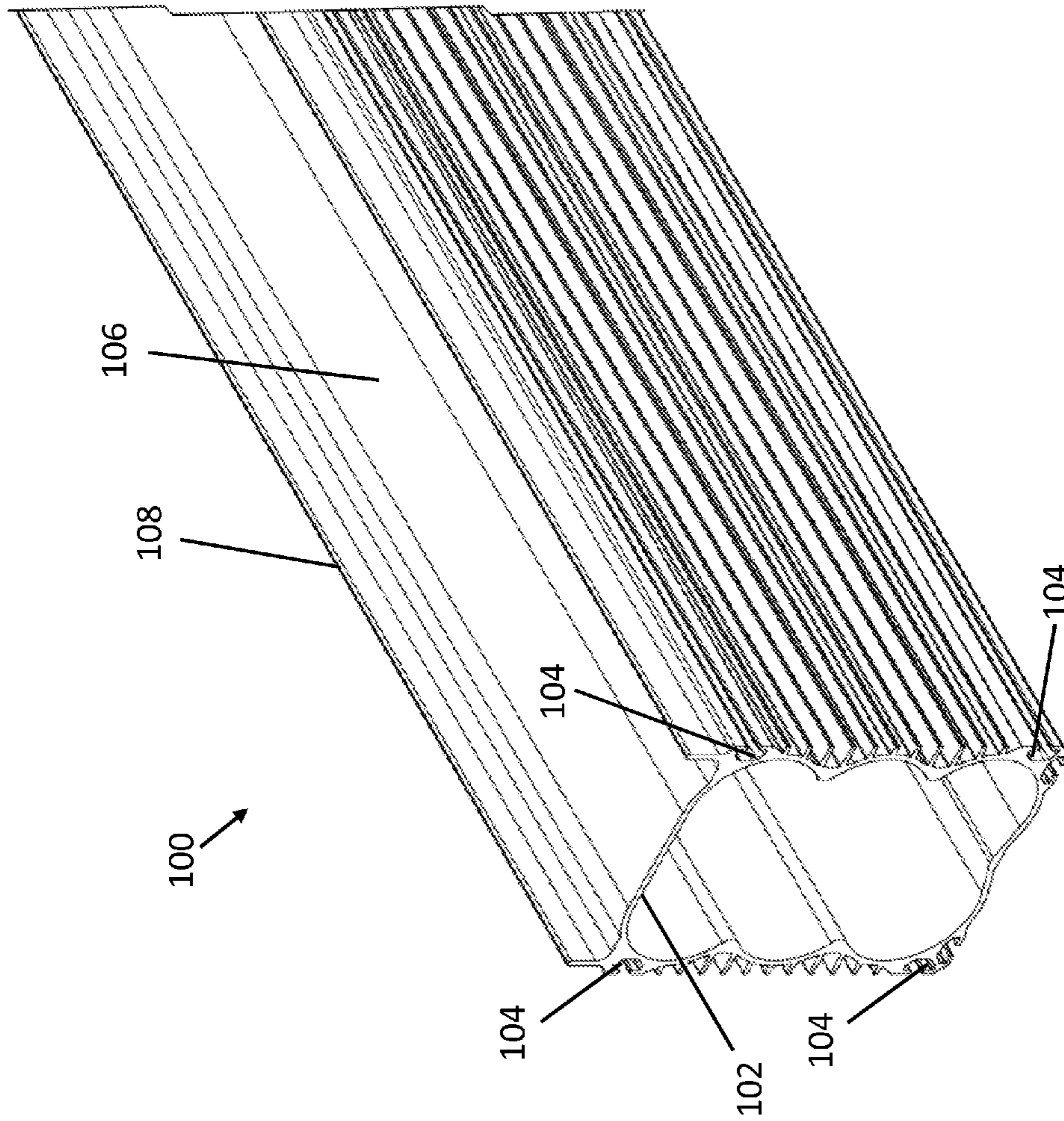

FIG. 1

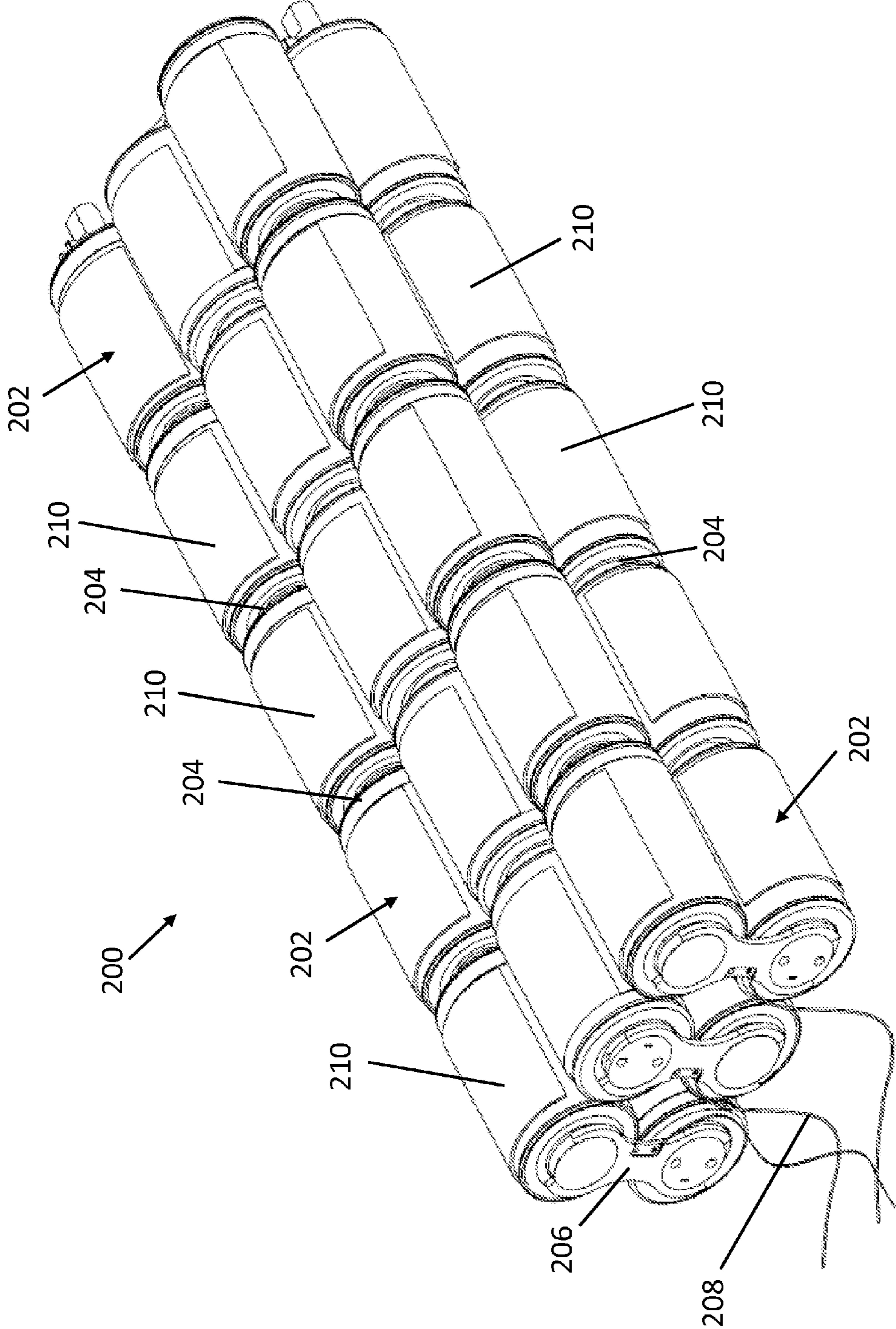

FIG. 2

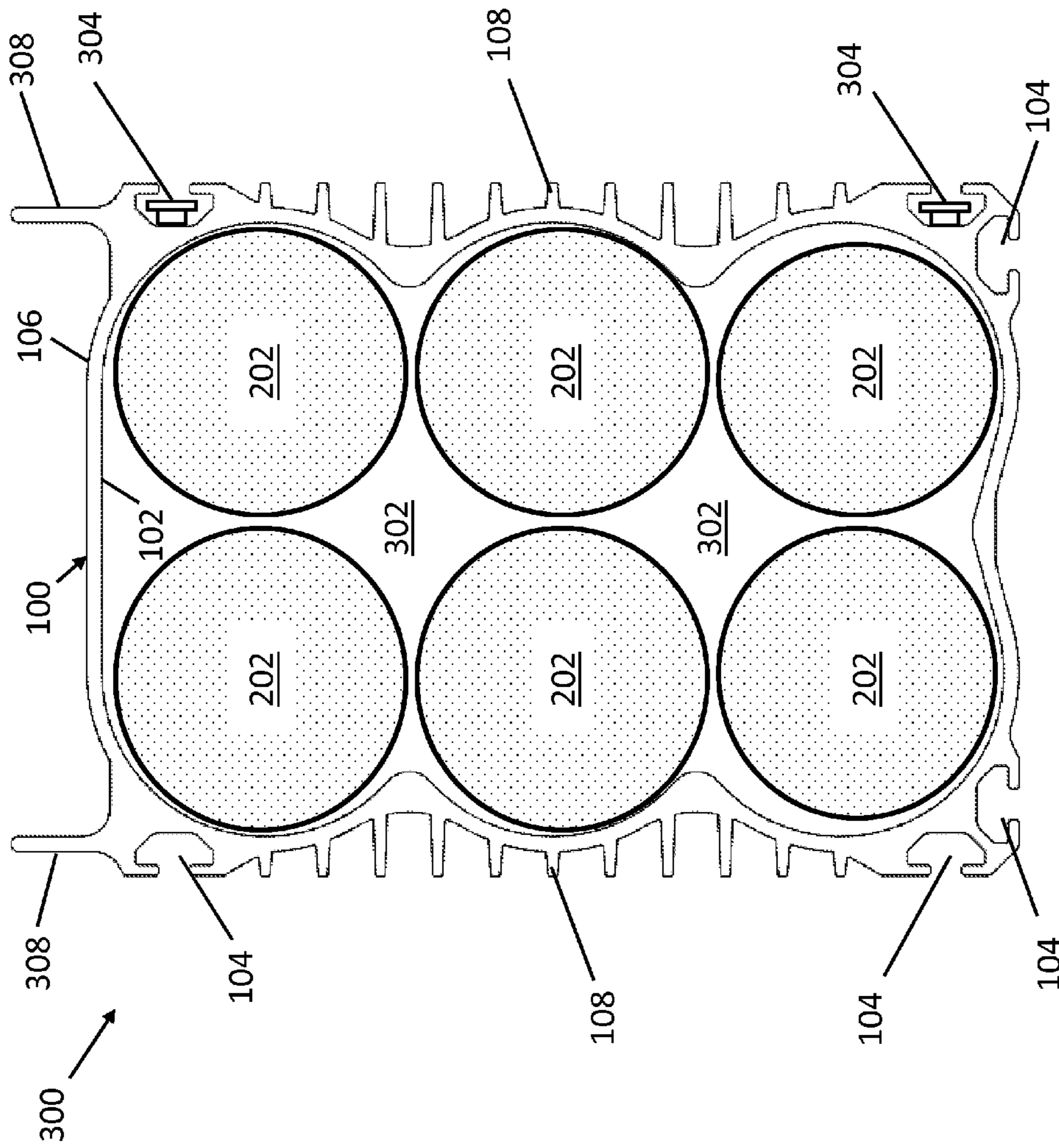

FIG. 3

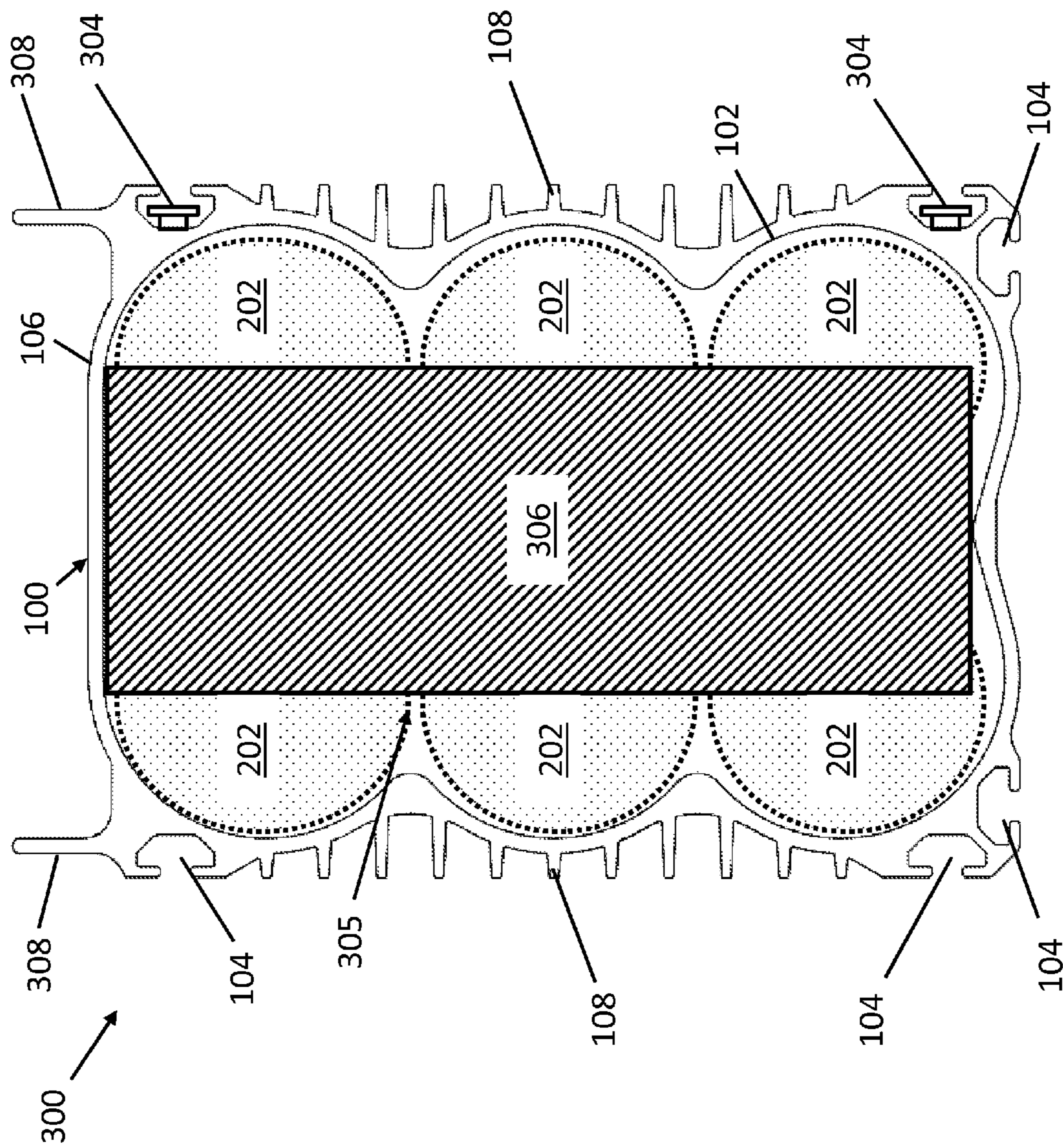

FIG. 4

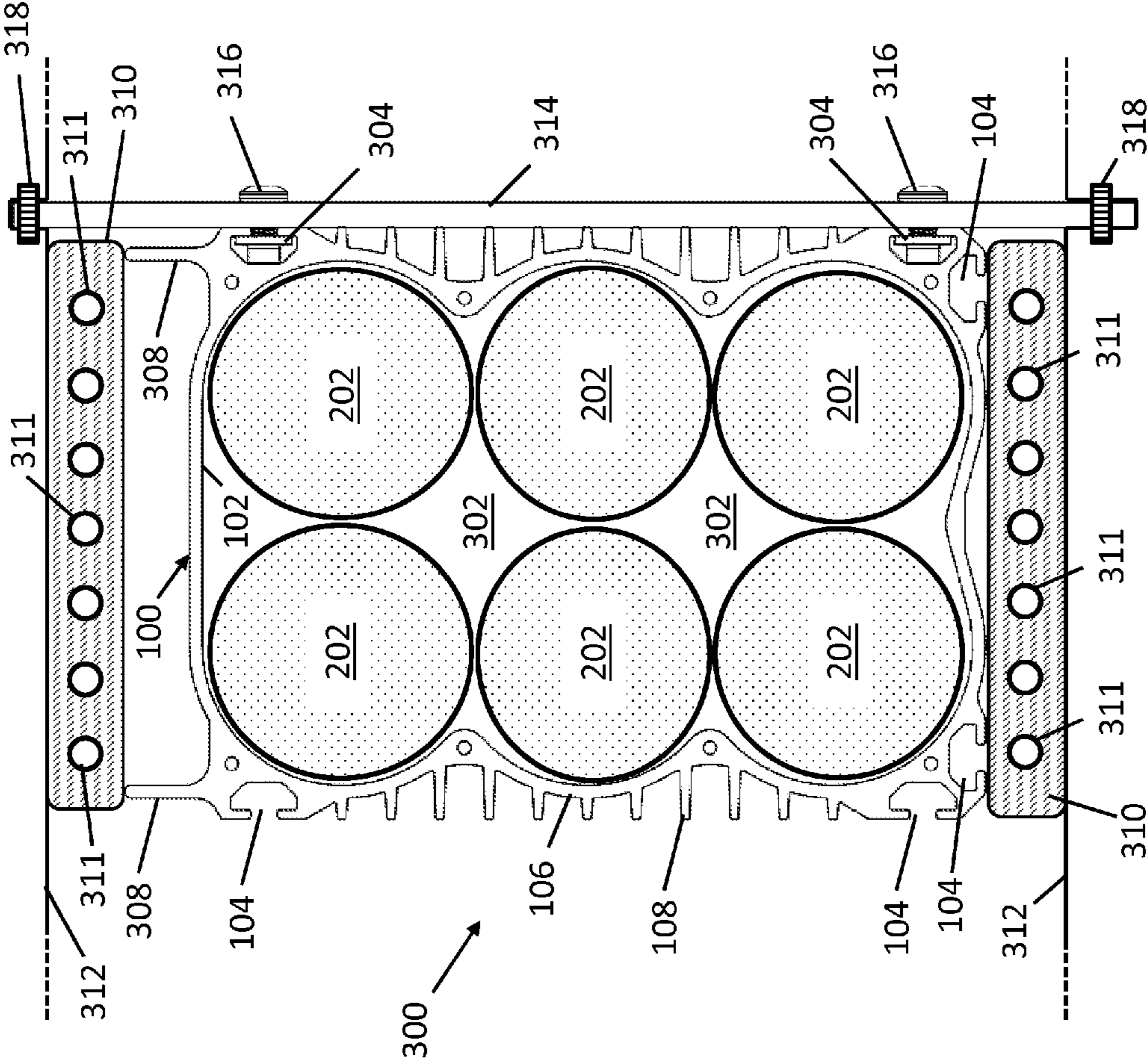

FIG. 5

1

APPARATUS FOR ENCLOSING ENERGY STORAGE DEVICES

BACKGROUND OF THE INVENTION

This disclosure relates generally to apparatuses for enclosing energy storage devices, and more particularly, to apparatuses which can include an elongated sleeve with slots for mechanically coupling one or more mounting rails to the elongated sleeve.

In conventional capacitor assemblies, a plurality of capacitor cells, ultracapacitor cells, batteries, or other energy storage devices may be loosely held together within a housing that can subject the cells to a certain amount of external forces, including vibratory forces. In some cases, these forces can exceed the strength of the securing components. The resulting vibratory action may reduce the durability and lifespan of the energy storage devices. In addition, the passage of electrical currents through particular materials, including ultracapacitors, may cause the materials therein to experience temperature increases. Apparatuses and methods for managing vibratory action, temperatures, and related variables is an ongoing design challenge in the field of energy storage products and components.

Some energy storage devices, including those with capacitor assemblies, may use adhesive substances and thermal inserts between capacitor cells. These components can dissipate heat generated during operation and reduce rotation and prevent any dislodging of the capacitor cells within the assembly. These components are typically positioned between connected or adjacent capacitors and may be located along or nearby the path of an electric current. To connect energy storage devices together, complex bonding mechanisms between numerous surfaces may be used. These design choices may reduce some performance aspects of the energy storage devices during operation, and can limit the opportunity for further modifications.

BRIEF DESCRIPTION OF THE INVENTION

A first aspect of the present disclosure provides an apparatus including: an elongated sleeve having a contoured interior configured to enclose each of a plurality of energy storage devices, wherein the elongated sleeve is composed at least partially of a thermally conductive material; and at least one slot disposed on an exterior surface of the elongated sleeve, wherein the at least one slot is configured to receive a coupling component for mechanically coupling a mounting rail to the elongated sleeve.

A second aspect of the present disclosure provides an apparatus including: an elongated sleeve having a contoured interior configured to enclose and engage a curved surface of each of a plurality of energy storage devices, wherein the elongated sleeve is composed at least partially of a thermally conductive material; at least one slot disposed on an exterior surface of the elongated sleeve; a coupling component disposed within the at least one slot, wherein the coupling component is configured to receive a mounting rail, and the mounting rail conducts heat from the plurality of energy storage devices and mechanically couples an external structure to the elongated sleeve.

A third aspect of the invention provides an apparatus including: a plurality of axially aligned energy storage devices each having a curved exterior surface, immediately adjacent energy storage devices being connected together at a welded joint; an elongated sleeve having a length and a contoured interior, the contoured interior enclosing the plu-

2

rality of energy storage devices and engaging the curved exterior surfaces of the plurality of energy storage devices, wherein the elongated sleeve is composed at least partially of a thermally conductive material; at least one slot disposed on an exterior surface of the elongated sleeve; a coupling component disposed within the at least one slot; and a mounting rail mechanically coupled to the coupling component, wherein the mounting rail conducts heat from the plurality of energy storage devices to an external structure mechanically coupled to the elongated sleeve through the mounting rail.

The illustrative aspects of the invention are designed to solve one or more of the problems herein described and/or one or more other problems not discussed.

BRIEF DESCRIPTION OF THE DRAWINGS

These and other features of the disclosure will be more readily understood from the following detailed description of the various aspects of the invention taken in conjunction with the accompanying drawings that depict various aspects of the invention.

FIG. 1 shows a partial perspective view of an elongated sleeve according to embodiments of the present disclosure.

FIG. 2 shows a perspective view of a plurality of energy storage devices according to embodiments of the present disclosure.

FIG. 3-5 show cross-sectional views of an apparatus according to embodiments of the present disclosure.

It is noted that the drawings of the invention are not necessarily to scale. The drawings are intended to depict only typical aspects of the invention, and therefore should not be considered as limiting the scope of the invention. It is understood that elements similarly numbered between the figures may be substantially similar as described with reference to one another. Further, in embodiments shown and described with reference to FIGS. 1-5, like numbering may represent like elements. Redundant explanation of these elements has been omitted for clarity. Finally, it is understood that the components of FIGS. 1-5 and their accompanying descriptions may be applied to any embodiment described herein. The detailed description explains embodiments of the invention, together with advantages and features, by way of example with reference to the drawings.

DETAILED DESCRIPTION OF THE INVENTION

In the following description, reference is made to the accompanying drawings that form a part thereof, and in which is shown by way of illustration specific exemplary embodiments in which the present teachings may be practiced. These embodiments are described in sufficient detail to enable those skilled in the art to practice the present teachings and it is to be understood that other embodiments may be used and that changes may be made without departing from the scope of the present teachings. The following description is, therefore, merely illustrative.

Elements described as being “disposed” or “disposed on” another element can be separably or inseparably positioned thereon or therein, embedded within, continuous with, and/or integral to the element on which the particular element is said to be disposed. When an element or layer is referred to as being “on,” “engaged to,” “disengaged from,” “connected to,” or “coupled to” another element or layer, it may be directly on, engaged, connected or coupled to the other element or layer, or intervening elements or layers may be

present. In contrast, when an element is referred to as being “directly on,” “directly engaged to,” “directly connected to,” or “directly coupled to” another element or layer, there may be no intervening elements or layers present. Other words used to describe the relationship between elements should be interpreted in a like fashion (e.g., “between” versus “directly between,” “adjacent” versus “directly adjacent,” etc.). As used herein, the term “and/or” includes any and all combinations of one or more of the associated listed items.

Spatially relative terms, such as “inner,” “outer,” “beneath,” “below,” “lower,” “above,” “upper,” “inlet,” “outlet,” “top,” “bottom,” and the like, may be used herein for ease of description to describe one element or feature’s relationship to another element(s) or feature(s) as illustrated in the figures. Spatially relative terms may be intended to encompass different orientations of the device in use or operation in addition to the orientation depicted in the figures. For example, if the device in the figures is turned over, elements described as “below” or “beneath” other elements or features would then be oriented “above” the other elements or features. Thus, the example term “below” can encompass both an orientation of above and below. The device may be otherwise oriented (rotated 90 degrees or at other orientations) and the spatially relative descriptors used herein interpreted accordingly.

The present disclosure relates generally to an apparatus for enclosing and transferring heat from several energy storage devices. Generally, embodiments of the present disclosure can include an elongated sleeve with a contoured surface. The contoured surface of the elongated sleeve can enclose a plurality of energy storage devices. The elongated sleeve, itself, can be composed of a “thermally conductive material.” A “thermally conductive material,” as used herein, can include any currently known or later developed material capable of transferring heat throughout and within a structure, such as a metal (e.g., pure metals such as aluminum or alloys such as steel), a ceramic material (e.g., potting materials), a thermally conductive organic material (e.g., thermally conductive plastics and/or epoxies), combinations thereof (e.g., glass fibers or mineral-filled plastics), and/or any other material with a thermal conductivity greater than that of air. A thermally conductive material may also include composite structures made up of two or more of these materials. The elongated sleeve can feature at least one slot disposed on its exterior surface. The slot(s) can be configured to include and/or receive a coupling component. The coupling component can mechanically couple a mounting rail to the elongated sleeve. The mounting rail and coupling component can form a thermally conductive connection between the apparatus and external structures located in a particular environment. Heat can thus be transferred outside the structure of the elongated sleeve through the mounting rail.

Turning to FIG. 1, an elongated sleeve 100 according to embodiments of the present disclosure is shown. Elongated sleeve 100 can be shaped to enclose a particular cross-sectional area with a corresponding number of energy storage devices included within the cross section. In an example embodiment, elongated sleeve 100 can enclose a cross section sized for housing a particular number (e.g., four, six, eight, etc.) energy storage devices therein. Elongated sleeve 100 may be composed of a thermally conductive material. Elongated sleeve 100 can also be manufactured as an extrusion, initially with any conceivable length dimension, such that elongated sleeve 100 can be modified (e.g., cut, machined, modified, or otherwise reduced in size) to a desired length for including a predetermined number of

energy storage devices for a particular application or deployment. Other features of elongated sleeve 100 discussed herein can similarly be manufactured to have any conceivable initial length, and then reduced in size to the desired length for a particular application.

A contoured interior 102 can be shaped for a particular apparatus or implementation, and can define the interior cross section of elongated sleeve 100, e.g., to engage similarly contoured exterior surfaces of energy storage devices housed therein. Elongated sleeve 100 can include one or more slots 104 thereon. As is discussed elsewhere herein, slots 104 can be configured to receive coupling components for mechanically coupling elongated sleeve 100 to other structures or components. An exterior surface 106 of elongated sleeve 100 may have a different type of profile and/or contour from contoured interior 102, and slots 104 may be disposed on exterior surface 106. In a particular embodiment, slots 104 may take the shape of an expanded chamber for removably retaining components, such as mechanical coupling components therein.

In an embodiment, slots 104 provided in the form of a chamber can include two intersecting cavities offset by a particular angle, such as a substantially perpendicular angle (e.g., by between approximately eighty degrees and approximately one hundred degrees), such that the two intersecting cavities at least partially form the shape of a “t” or “T.” As used herein, the term “approximately” in relation to a specified numerical value (including percentages of base numerical values) can include all values within a substantially similar range, e.g., fifteen percentage points of above or below, the enumerated value or percentage. An approximate value can also include all other values which cause no operational difference or substantial operational difference between the approximate value and the enumerated value. The term approximately can also include other specific values or ranges where specified herein. In the example shown in FIGS. 1 and 3-5, slots 104 include an at least partially expanded or mushroom-shaped chamber or cavity for retaining coupling components therein with a cross-sectional area greater than a smaller-area or bottlenecked portion within slot 104. Slots 104 can be shaped, machined, modified, etc. into any desired shape corresponding to a particular mechanical coupling component in embodiments of the present disclosure, and as examples can include V-shaped slots, Y-shaped slots, substantially circular or substantially rectangular slots, slots with at least partially irregular contours and/or geometries, etc.

Slots 104 can be positioned on or within exterior surface 106 of elongated sleeve 100 at any desired location, and in a particular embodiment two slots 104 can be positioned on opposing sides of elongated sleeve 100. Slots 104 being positioned on opposing sides of elongated sleeve 100 can provide symmetry and structural support from components coupled to and/or positioned within slots 104. Elongated sleeve 100 can also include one or more thermally conductive fins 108 positioned on exterior surface 104. Thermally conductive fins 108 can be in the form of any protrusion, fixture, addition, component, etc., for increasing the surface area of elongated sleeve 100. Thermally conductive fins 108 can be composed of a thermally conductive material, e.g., the same material as elongated sleeve 100 or a different material. Slots 104 and/or thermally conductive fins 108 can be formed with elongated sleeve 100 as part of a single extrusion, and in embodiments may be integral to the structure of elongated sleeve 100. Furthermore, slots 104 and/or conductive fins 108 may run along all or substantially all of a length dimension of elongated sleeve 100, such that

5

elongated sleeve **100** including slots **104** and/or conductive fins **108** can be manufactured in a larger size and cut, machined, shaped, and/or otherwise reduced in size to a reduced length usable for one or more particular applications. Where slots **104** extend across the length of elongated sleeve **100**, slots **104** can include multiple mechanical coupling components therein, or other larger components capable of being affixed to or retained therein slots **104** with a particular length. In addition or alternatively, slots **104** extending across the length of elongated sleeve **100** can be configured to receive external coupling components to retain or matingly engage all or a portion of the length of elongated sleeve **100**.

Turning to FIG. 2, a plurality **200** of energy storage devices **202** according to embodiments of the present disclosure is shown. Several energy storage devices **202** in plurality **200** can be connected together in series. Energy storage devices **202** can be in the form of ultracapacitors or other devices for storing a particular electrical charge. Axially adjacent energy storage devices **202** can be connected end to end via welded joints **204**. Welded joints **204** can be formed through a spot weld, a circumferential weld, a TIG (gas tungsten arc) weld, a MIG (gas metal arc) weld, an EB (electric beam) weld, a laser weld, or any other types of welding currently known or later developed. In an example embodiment, laser welding can be used to form welded joints **204** by welding two energy storage devices **202** together along a single circumferential line of each axially adjacent energy storage device cell **202**.

Two sets of axially connected energy storage devices **202** can be electrically connected to each other by way of a bus bar **206** positioned between and contacting two axially terminal energy storage devices **202** of the two sets. Bus bar **206** can be composed of an electrically and thermally conductive material such as a metal, and in an embodiment may be composed of the same material as the electrically conductive components of energy storage devices **202** (e.g., copper, aluminum, silver, etc.). In addition, plurality **200** of energy storage devices **202** can be electrically connected to a load or other component by way of a wiring harness **208**. One or more energy storage devices **202** can include a thermal insert **210** bonded thereto. Thermal insert **210** may be in the form of a thermally conducting, electrically insulative material to provide a form of thermal communication (e.g., a thermal conduit or heat sink) between plurality **200** of energy storage devices **202** and an external environment and/or other thermally conductive materials. Thermal insert **210** can have a material composition of a plastic material, a ceramic material, or any similar substance capable of insulating an electrical current while transmitting heat from energy devices **202** and adding structural support to plurality **200** of energy storage devices **202**.

Energy storage devices **202** can contact contoured interior **102** (FIG. 1) of elongated sleeve **100** (FIG. 1) through thermal insert **210**, which in turn can act as a bridge or transitional component. The configuration of thermal insert **210** optionally allows heat to be communicated from energy storage devices **202** without altering the connection between them, including weld bonds **204**, such that one or more thermal inserts **210** can be added to or removed from energy storage devices **202** as desired. Embodiments of the disclosure can use any number of thermal inserts **210** with energy storage devices **202** to suit varying operational and/or heat distribution requirements. In an alternative embodiment, some or all thermal inserts **210** can be omitted and energy

6

storage devices **202** can transfer heat to other components and/or structures by directly contacting those components and/or structures.

Turning to FIG. 3, an apparatus **300** according to embodiments of the present disclosure is shown. Apparatus **300** can include elongated sleeve **100** with contoured interior **102** enclosing plurality **200** (FIG. 2) of energy storage devices **202**. In an example embodiment, as is shown in the lower-left and right of FIG. 3, contoured interior **102** can engage similarly curved exterior surfaces of energy storage devices **202**. Energy storage devices **202** can be arranged in multiple rows, with each of the different rows being in thermal communication with contoured interior **102** of elongated sleeve **100**. In this arrangement, each energy storage device **202** can transmit heat directly to elongated sleeve **100** without other energy storage devices **202** being positioned between a single energy storage device **202** and at least part of contoured interior **102**. In an example embodiment, as is shown in FIGS. 2-5, a cross-section of apparatus **300** can include six energy storage devices **202** provided in three rows of two, i.e., a “two by three” arrangement. Alternatively, energy storage devices can include any number of rows/columns where the other row/column includes no more than two energy storage devices (e.g., two by two, two by four, two by eight, two by ten, two by fifty, two by one hundred, etc.), such that each energy storage device **202** can be in contact with elongated sleeve **100**. For example, in a two by ten arrangement, each energy storage device **202** can directly contact elongated sleeve **100** and transfer heat thereto. Where excess temperature increase is not a significant risk during operation, other embodiments can include both rows and columns with more than three and/or odd numbers of energy storage devices therein. In addition or alternatively, energy storage devices **202** can be in a non-quadrilateral and/or complex geometry without conventional groups of rows and/or columns, such as a substantially linear, circular, pentagonal, heptagonal, parallelogram-shaped, trapezoidal, octagonal, or other type of arrangement where each energy storage device is not separated from elongated sleeve **100** by another energy storage device **202** in at least one direction. Although thermal inserts **210** are omitted from FIGS. 3-5 for the purposes of clarity and convenience, it is understood that thermal inserts **210** can contact the exterior surface of one or more energy storage devices **202** in apparatus **300**, as is shown by example in FIG. 2.

A thermal transmitting mechanism **302** can be interposed between contoured interior **102** and energy storage devices **202**. Thermal transmitting mechanism **302** may be electrically non-conductive, and as examples can include ceramic materials (e.g., potting materials), plastics, gaseous materials, and/or other thermally conductive materials with electrically insulative properties. As is discussed elsewhere herein, elongated sleeve **100** can include one or more slots **104** configured to include or receive a coupling component **304** therein, in addition to several thermally conductive fins **108** positioned on exterior surface **106**. Slots **104** can be disposed within multiple locations and/or sides of exterior surface **108** of elongated sleeve **100**. As is shown in FIG. 3, elongated sleeve **100** can include two slots **104** positioned in substantially perpendicular orientations relative to each other, such that each slot **104** can engage or interface with different types of components and/or components with differing orientations.

Coupling component **304** can include any mechanical component for mechanically coupling two components, such as a fastener, a matingly engagable slot for an inserted

beam, a flange coupling, a disc coupling, a threaded coupling, a fluid coupling, a diaphragm coupling, a gear coupling, a joint, a bolting fixture, a mount, etc. In the example of FIG. 3, an embodiment of coupling component **304** is shown in the form of a bolting fixture. Coupling components **304** can be positioned within any and/or all slots **104** of elongated sleeve **100**. Though two coupling components **304** are shown by example in FIG. 3, any desired number of coupling components **304** can be used, and in any desired number or combination of slots **104**. In any case, coupling components **304** can be composed of a thermally conductive material, and can include the same material composition as elongated sleeve **100** or can be composed of a different material. In other embodiments, bolts or other mechanical instrument for coupling elements to coupling components **304** can extend through or be affixed to other elements, such as elongated sleeve **100**, exterior fixtures and/or housings, rails (e.g., mounting rail(s) **314** discussed herein with respect to FIG. 5), and/or other components discussed herein or used generally in apparatus **300** or an energy storage device assembly.

Although coupling components **304** are shown by example in FIGS. 3-5 as being distinct or structurally separated items mounted on or otherwise coupled to elongated sleeve **100** and/or slots **104**, other embodiments are contemplated. For example, coupling component(s) **304** can be embodied as a specific portion or surface of elongated sleeve **100** and/or slots **104** for engaging other coupling components **304**, one or more mounting rails, or other exterior components. In this alternative, coupling components **304** in the form of surfaces may be integral to elongated sleeve **100** and/or slots **104**, and can be shaped, machined, modified, etc., to engage a variety of coupling components **304** and/or other structures. In this embodiment, coupling components **304** can provide a surface which allows for movement of other structures and elongated sleeve **100** relative to each other along one or more particular axes, e.g., to provide sliding engagement for horizontal and/or vertical motion of these components relative to each other. In an embodiment, coupling components **304** can provide for sliding engagement of elongated sleeve **100** with a mounting frame, housing, and/or other point of installation, such that elongated sleeve **100** can be slid into and out of the mounting frame for installation, removal, repair, maintenance, etc.

Referring to FIG. 4, another cross-sectional view of apparatus **300** is shown. Apparatus **300** can include a structural thermal bridge **305** positioned at, e.g., an axial end of a group of energy storage devices **202**. Structural thermal bridge **305** can include one or more thermally conductive components for physically securing energy storage devices **202** within elongated sleeve **100** and for dissipating heat from within elongated sleeve **100** to exterior components (e.g., thermally conductive fins **108**). In an example embodiment, structural thermal bridge **305** can include or be in the form of a thermal plate **306**, which can be composed of a thermally conductive material such as a metal, a plastic, a ceramic material, etc. In other embodiments, structural thermal bridge **305** can include additional thermally conductive materials connected to thermal plate **306** to attach structural thermal bridge **305** to elongated sleeve **100**. Thermal plate **306** can engage the axial ends of several energy storage devices **202** (i.e., be located adjacent to or in physical contact therewith, with or without intervening elements being positioned therebetween) and can be positioned adjacent to an axial terminus of elongated sleeve **100**. In addition, structural thermal bridge **305** can be in thermal

communication with thermal transmitting mechanism(s) **302** by any currently known or later developed form of structural coupling, such as forming a part of thermal transmitting mechanism **302**, or contacting thermal transmitting mechanism **302**. In another embodiment, structural thermal bridge can be proximal to thermal transmitting mechanism **302** with one or more thermally conductive elements positioned therebetween.

Turning to FIG. 5, another cross-sectional view of apparatus **300**, with additional components included, is shown. In an embodiment, at least one thermally conductive fin **108** can be provided in the form of a structural fin **308**. Structural fin **308** can be structurally distinguishable by, e.g., being larger than other thermally conductive fins **108** and/or extending in a particular direction. As is shown by example in FIGS. 3-5, structural fin **308** can be positioned on a particular surface (e.g., the top or bottom) of elongated sleeve **100**. More specifically, structural fin **308** can extend in the same direction as an edge of slot(s) **104** (i.e., an interior edge of a T-slot), so that when other components contact structural fin(s) **308**, the ends of structural fins **308** support the weight of elongated sleeve **100** at particular locations (e.g., centers of mass of elongated sleeve **100**, coupling component(s) **304**, and/or any components thereof or attached thereto). Structural fin **308** can provide structural support and/or separation from a shield **310** for elongated sleeve **100**. Shield **310** can be positioned between structural fin **308** of elongated sleeve **100** and an external structure **312** outside elongated sleeve **100**, and in an example embodiment can be positioned above and/or below energy storage devices **202**. In addition or alternatively, a portion of exterior surface **106** can contact shield **310** directly without structural fin **308** being positioned therebetween. External structure **312** can take the form of an external component of a larger energy storage device assembly such as, without limitation, one or more structures such as: housings (e.g., ultracapacitor housings), substantially flat or rounded plates, heat sinks, shock absorbers, electrical cages, conductive or non-conductive casings, walls, floors, ceilings, other elongated sleeves **100**, other assemblies for structurally connecting elongated sleeve **100** to a larger frame, etc.

Shield **310** can be composed of one or more thermally conductive materials discussed elsewhere herein, and may have the same material composition as elongated sleeve **100** or a different material composition. Shield **310** may include other heat transfer materials and/or properties therein where desired. For example, shield **310** can include channels **311** therein for transmitting a refrigerant (e.g., cooling air or water) to absorb heat dissipated from elongated sleeve **100** through structural fin **308**. Shield **310** is shown by example in FIG. 5 as contacting two opposing sides of elongated sleeve **100**, and it is understood that other arrangements are possible according to embodiments of the present disclosure. For instance, where desired, shield **310** can be disposed circumferentially about exterior surface **106**, thermally conductive fins **108**, and/or structural fins **308** of elongated sleeve **100**. In other embodiments, shield **310** may enclose or contact only part of exterior surface **106**, thermally conductive fins **108**, and/or structural fins **308**. In yet another embodiment, shield **310** may enclose structural fin(s) **308** or thermally conductive fin(s) **108** without contacting elongated sleeve **100** itself. In other embodiments, as is shown in FIG. 5, shield **310** can contact structural fin(s) **308** on top of elongated sleeve **100** while directly contacting a bottom surface of elongated sleeve **100**. Relative to the structure of a larger assembly, shield **310** can be a casing, a housing, a structural support, an interchangeable sleeve, an addition for

particular applications, and/or other items adapted for enclosing elongated sleeve 100 therein.

Continuing to refer to FIG. 5, a mounting rail 314 can be mechanically coupled to coupling component 304. Mounting rail 314 in turn can mechanically couple elongated sleeve 100 to external structure 312. Where coupling component 304 is in the form of a bolting fixture, mounting rail 314 can be mechanically coupled thereto by way of a bolt 316. Here, bolt 316 can extend through a bolt hole (not shown) within mounting rail 314 to contact coupling component 304 to be coupled (i.e., connected, affixed, or otherwise secured) thereto. The mechanical connection between mounting rail 314 and external structure 312 can be provided via a fastener 318 such as a bolt, screw, adhesive connection, and/or other type of instrument for mechanically connecting mounting rail 314 to a particular structure, such as a housing, point of installation, other energy storage device assembly, etc. Mounting rail 304 can be composed of any currently known or later developed thermally-conductive material, and as examples can be composed of a metal, a ceramic material, an organic material, and/or other types of currently known or later developed materials capable of transmitting heat. When coupled to external structure 312 and elongated sleeve 100, mounting rail 314 can conduct heat from energy storage devices 202 external structure 312 to dissipate heat from energy storage devices 202.

Embodiments of the present disclosure can provide several technical and commercial advantages, some of which are discussed herein by way of example. Manufacturing and/or modifying a housing to include several slots and/or couplings to external components such as mounting rails can enhance the dissipation of heat from multiple energy storage devices while providing a structural connection to external housings, components, other assemblies of energy storage devices, cooling systems, and the like. Additionally, embodiments of the present disclosure can provide an increased number of thermal dissipating structures, such as thermal fins, in comparison to conventional housing. Embodiments of the present disclosure can also reduce the effect of vibrations or other external forces on an assembly of energy storage devices.

The terminology used herein is for the purpose of describing particular embodiments only and is not intended to be limiting of the disclosure. As used herein, the singular forms “a,” “an,” and “the” are intended to include the plural forms as well, unless the context clearly indicates otherwise. It will be further understood that the terms “comprises” and/or “comprising,” when used in this specification, specify the presence of stated features, integers, steps, operations, elements, and/or components, but do not preclude the presence or addition of one or more other features, integers, steps, operations, elements, components, and/or groups thereof.

This written description uses examples to disclose the invention, including the best mode, and to enable any person skilled in the art to practice the invention, including making and using any devices or systems and performing any incorporated methods. The patentable scope of the invention is defined by the claims, and may include other examples that occur to those skilled in the art. Such other examples are intended to be within the scope of the claims if they have structural elements that do not differ from the literal language of the claims, or if they include equivalent structural elements with insubstantial differences from the literal language of the claims.

What is claimed is:

1. An apparatus comprising:

an elongated sleeve having a contoured interior configured to enclose each of a plurality of energy storage devices, wherein the elongated sleeve is composed at least partially of a thermally conductive material; and at least one slot disposed on an exterior surface of the elongated sleeve, and extending substantially in parallel with an axial length of the elongated sleeve, wherein the at least one slot extends continuously between opposite axial ends of the elongated sleeve, and wherein the at least one slot is configured to receive a coupling component for mechanically coupling a mounting rail to the elongated sleeve.

2. The apparatus of claim 1, further comprising a structural thermal bridge including at least one thermal plate engaging an end of a pair of adjacent energy storage devices to physically secure the plurality of energy storage devices and thermally communicate heat therefrom.

3. The apparatus of claim 1, wherein the at least one slot is shaped to retain a plurality of coupling components therein for mechanically coupling the elongated sleeve to a plurality of mounting rails.

4. The apparatus of claim 1, wherein the at least one slot is shaped to retain an end of the coupling component therein, and wherein the at least one slot further includes a passage connecting the at least one slot to the exterior surface of the elongated sleeve, wherein the passage is shaped for a portion of the coupling component to pass therethrough.

5. The apparatus of claim 1, further comprising a plurality of thermally conductive fins extending from the exterior surface of the elongated sleeve, wherein at least one of the plurality of thermally conductive fins extends substantially in parallel with the at least one slot and the axial length of the elongated sleeve.

6. The apparatus of claim 5, further comprising a thermally conductive shield for the elongated sleeve positioned between at least one of the plurality of thermally conductive fins and an external structure positioned outside the elongated sleeve.

7. The apparatus of claim 1, wherein the at least one slot includes a pair of slots disposed on opposing exterior surfaces of the elongated sleeve.

8. The apparatus of claim 1, wherein the coupling component is composed of a thermally conductive material.

9. The apparatus of claim 1, further comprising a thermal transmitting mechanism interposed between the elongated sleeve and the plurality of energy storage devices.

10. The apparatus of claim 1, wherein the plurality of energy storage devices are arranged in a plurality of rows, each of the plurality of rows being in thermal communication with the contoured interior of the elongated sleeve.

11. An apparatus comprising:

an elongated sleeve having a contoured interior configured to enclose and engage a curved surface of each of a plurality of energy storage devices, wherein the elongated sleeve is composed at least partially of a thermally conductive material;

at least one slot disposed on an exterior surface of the elongated sleeve; and

a coupling component disposed within the at least one slot, the coupling component receiving a mounting rail therein, wherein the mounting rail and the coupling component conduct heat from the plurality of energy storage devices and mechanically couple an external structure to the elongated sleeve.

11

12. The apparatus of claim **11**, further comprising a structural thermal bridge including at least one thermal plate engaging an end of a group of adjacent energy storage devices to physically secure the plurality of energy storage devices and thermally communicate heat therefrom.

13. The apparatus of claim **11**, wherein the at least one slot comprises a substantially T-shaped slot.

14. The apparatus of claim **13**, further comprising an additional slot disposed on the exterior surface of the elongated sleeve, the additional slot having a substantially perpendicular orientation relative to the at least one slot.

15. The apparatus of claim **11**, further comprising a plurality of thermally conductive fins extending from the exterior surface of the elongated sleeve and contacting the external structure.

16. The apparatus of claim **11**, wherein the coupling component comprises a bolting fixture.

17. The apparatus of claim **11**, wherein the at least one slot includes a pair of slots disposed on opposing exterior surfaces of the elongated sleeve.

18. The apparatus of claim **11**, wherein the coupling component is composed of a thermally conductive material.

12

19. The apparatus of claim **11**, further comprising a thermal transmitting mechanism interposed between the elongated sleeve and the plurality of energy storage devices.

20. An apparatus comprising:

a plurality of axially aligned energy storage devices each having a curved exterior surface, immediately adjacent energy storage devices being connected together at a welded joint;

an elongated sleeve having a length and a contoured interior, the contoured interior enclosing the plurality of energy storage devices and engaging the curved exterior surfaces of the plurality of energy storage devices, wherein the elongated sleeve is composed at least partially of a thermally conductive material;

at least one slot disposed on an exterior surface of the elongated sleeve;

a coupling component disposed within the at least one slot; and

a mounting rail mechanically coupled to the coupling component, wherein the mounting rail conducts heat from the plurality of energy storage devices to an external structure mechanically coupled to the elongated sleeve through the mounting rail.

* * * * *