



US009715123B2

(12) **United States Patent**
Arntsen et al.

(10) **Patent No.:** **US 9,715,123 B2**
(45) **Date of Patent:** **Jul. 25, 2017**

(54) **GREEN AND RED DESPECKLING**

9/3161 (2013.01); H01S 3/005 (2013.01);
H01S 3/2375 (2013.01); H01S 2301/02
(2013.01)

(71) Applicant: **Laser Light Engines, Inc.**, Salem, NH
(US)

(58) **Field of Classification Search**

None
See application file for complete search history.

(72) Inventors: **John Arntsen**, Manchester-by-the-Sea,
MA (US); **Barret Lippey**, Belmont,
MA (US)

(56) **References Cited**

(73) Assignee: **Laser Light Engines, Inc.**, Salem, NH
(US)

U.S. PATENT DOCUMENTS

(*) Notice: Subject to any disclaimer, the term of this
patent is extended or adjusted under 35
U.S.C. 154(b) by 312 days.

6,975,294	B2 *	12/2005	Manni	G02B 27/48
					345/32
2007/0291810	A1 *	12/2007	Luo	H01S 3/0627
					372/50.121
2008/0075130	A1 *	3/2008	Mizuuchi	H04N 9/3129
					372/6
2008/0239171	A1 *	10/2008	Inoue	H04N 9/3111
					348/744
2014/0071406	A1 *	3/2014	Manni	G02B 27/48
					353/31
2014/0104578	A1 *	4/2014	Madamopoulos	.	G03B 21/2033
					353/20

(21) Appl. No.: **13/964,332**

(22) Filed: **Aug. 12, 2013**

(65) **Prior Publication Data**

US 2013/0329755 A1 Dec. 12, 2013

Related U.S. Application Data

(63) Continuation-in-part of application No. 12/962,185,
filed on Dec. 7, 2010, now Pat. No. 8,786,940.

(51) **Int. Cl.**

G02F 1/35	(2006.01)
H01S 3/02	(2006.01)
G02B 27/48	(2006.01)
H01S 3/30	(2006.01)
H04N 9/31	(2006.01)
H01S 3/00	(2006.01)
H01S 3/23	(2006.01)

(52) **U.S. Cl.**

CPC **G02B 27/48** (2013.01); **H01S 3/2391**
(2013.01); **H01S 3/302** (2013.01); **H04N**

* cited by examiner

Primary Examiner — Hemang Sanghavi

(74) *Attorney, Agent, or Firm* — GTC Law Group PC &
Affiliates

(57) **ABSTRACT**

An apparatus and method for despeckling that includes a pulsed green laser, a green laser diode assembly, and stimulated Raman scattering light formed in an optical fiber. The stimulated Raman scattering light is divided into green light and red light. The green light from the stimulated Raman scattering is combined with the green laser diode assembly to form a green primary light. The red light from the stimulated Raman scattering forms a red primary light. The green primary light and the red primary light are used to project a digital image.

20 Claims, 19 Drawing Sheets

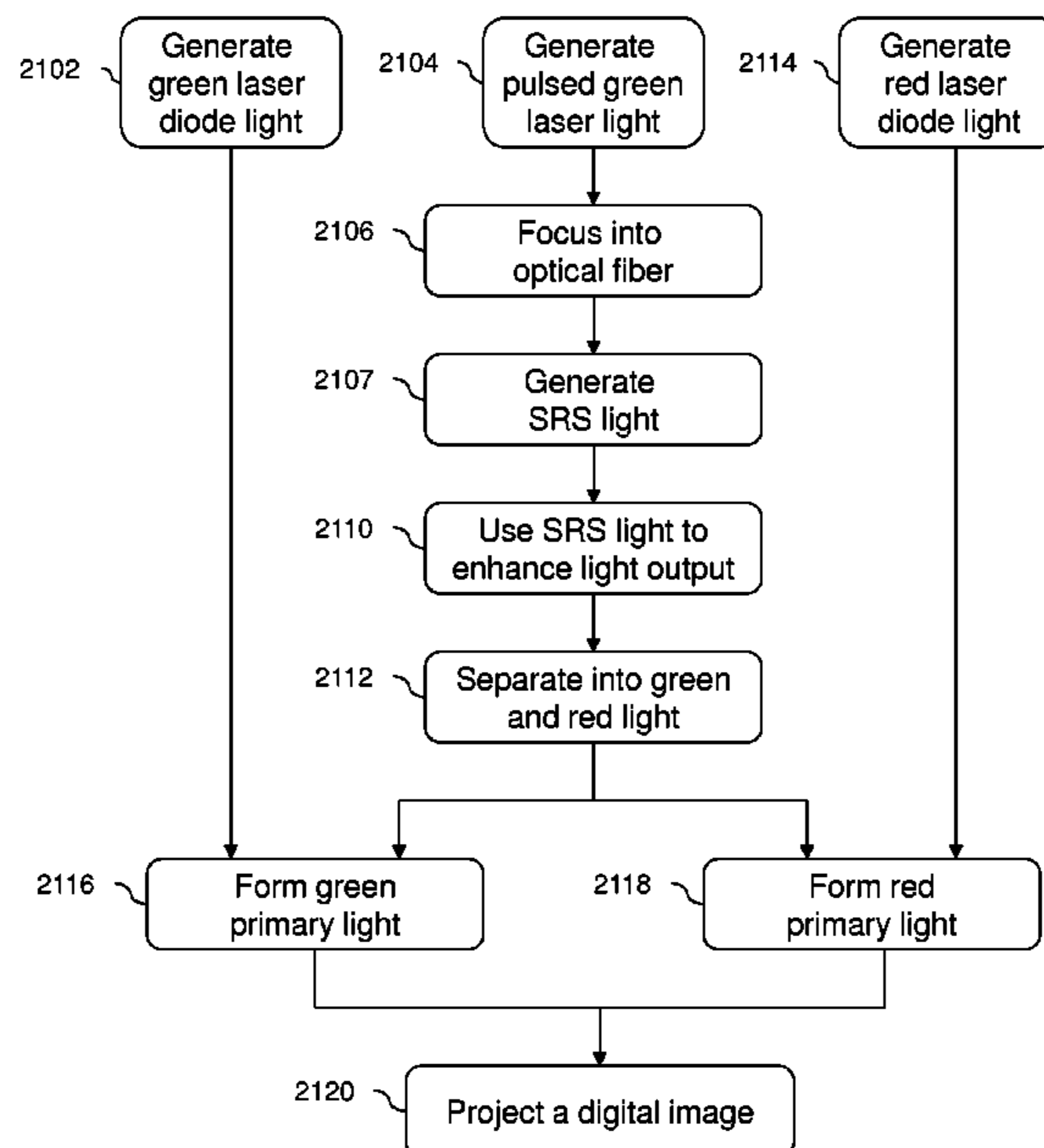

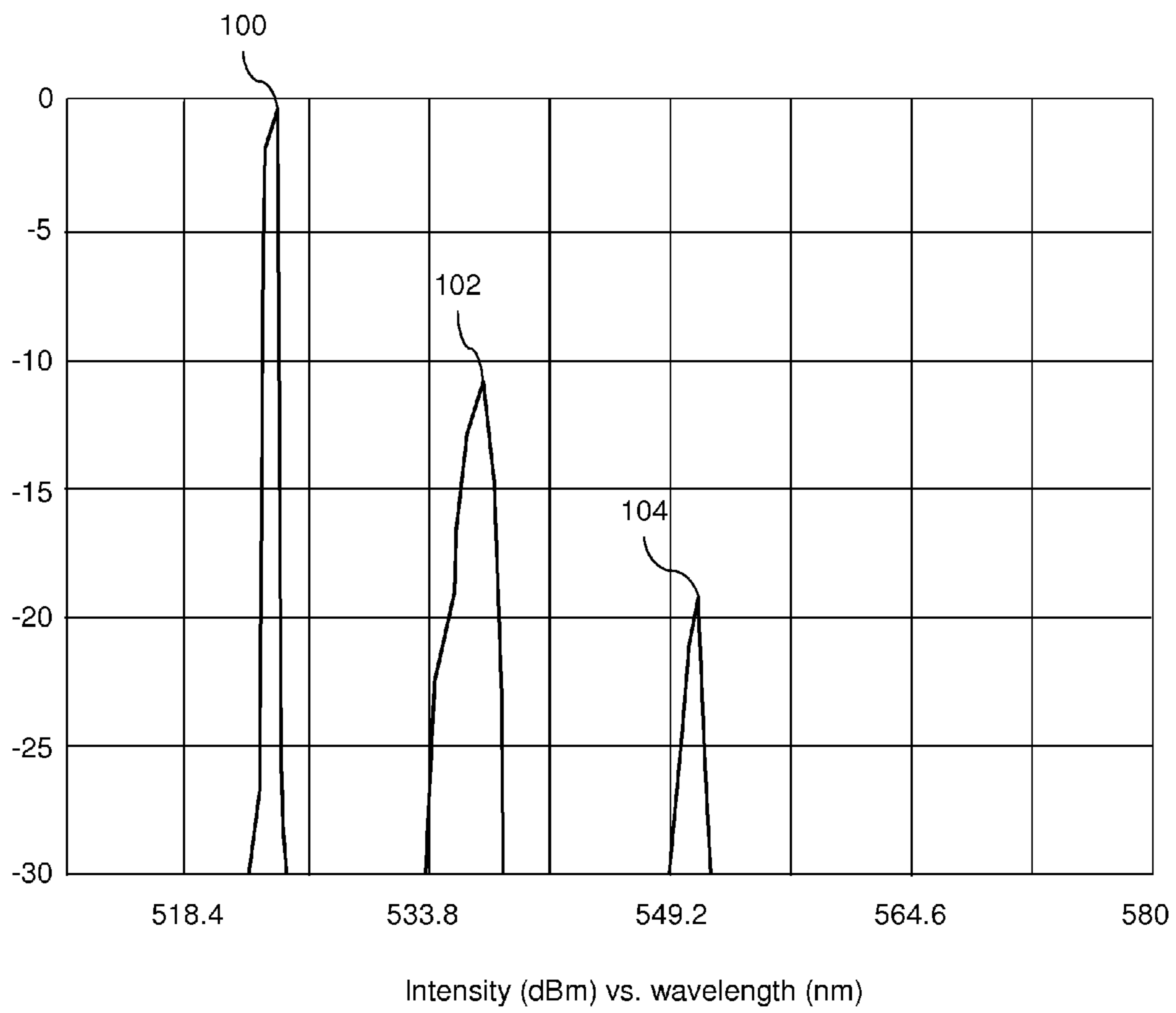

FIG. 1

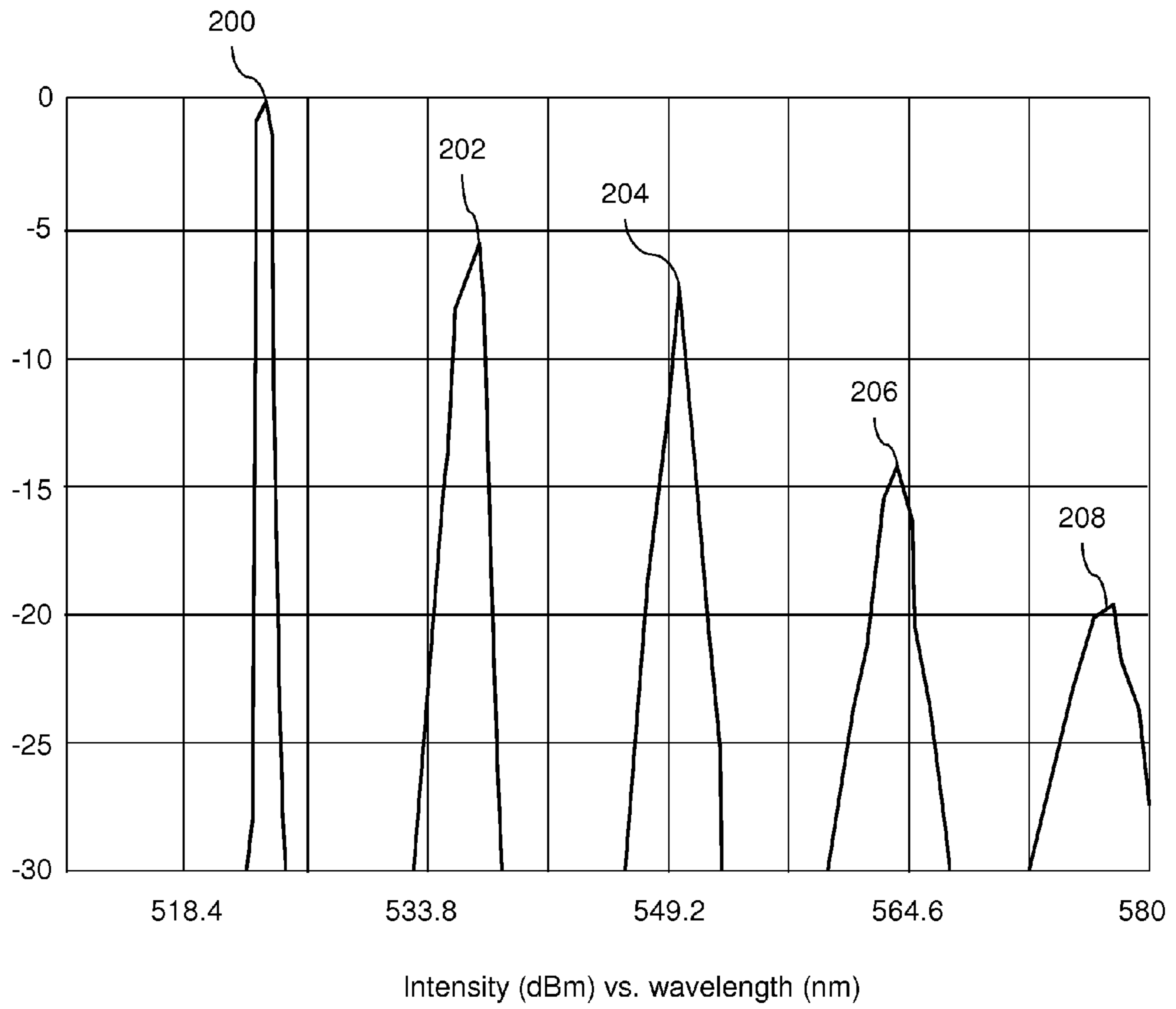

FIG. 2

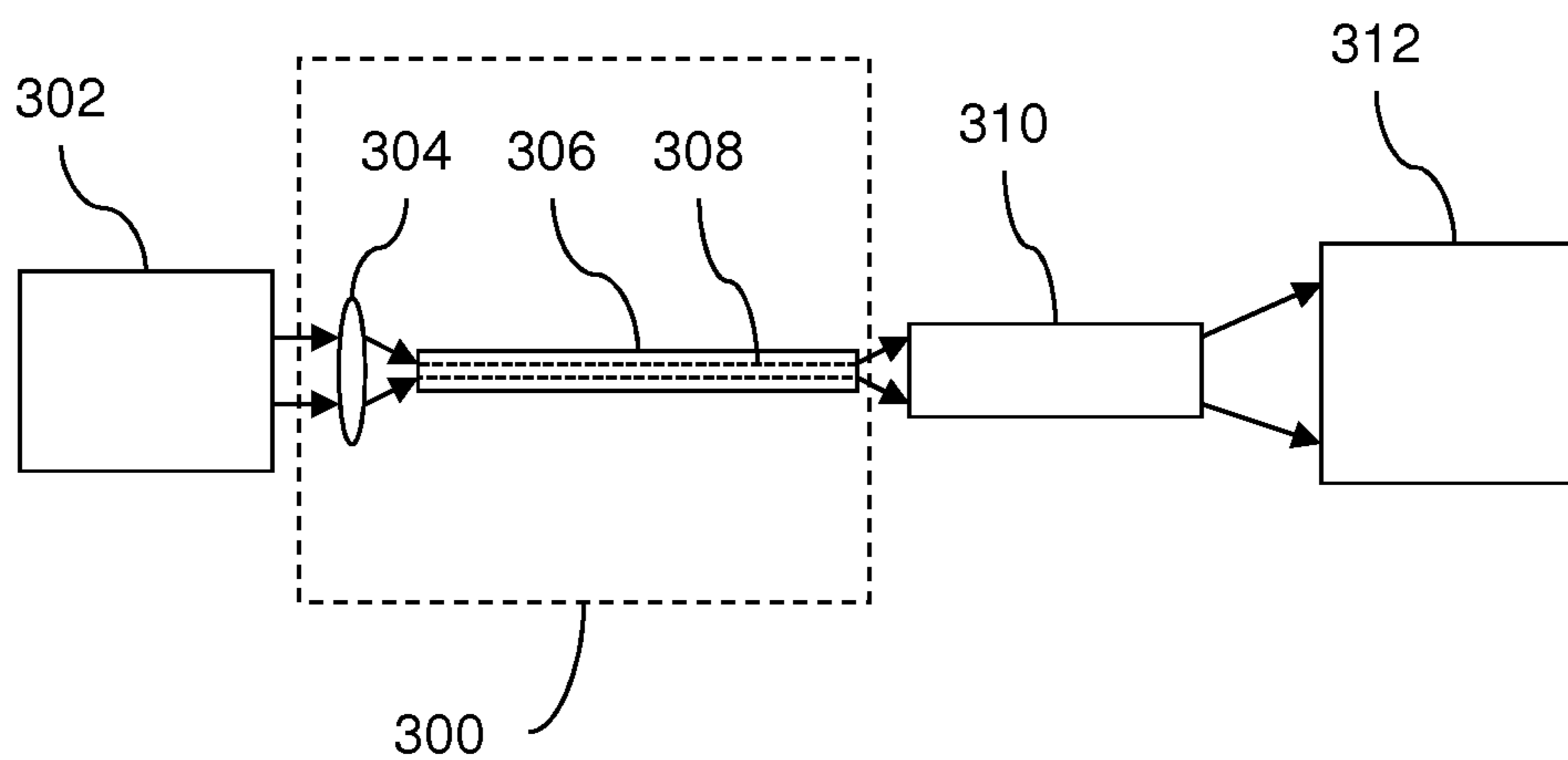

FIG. 3

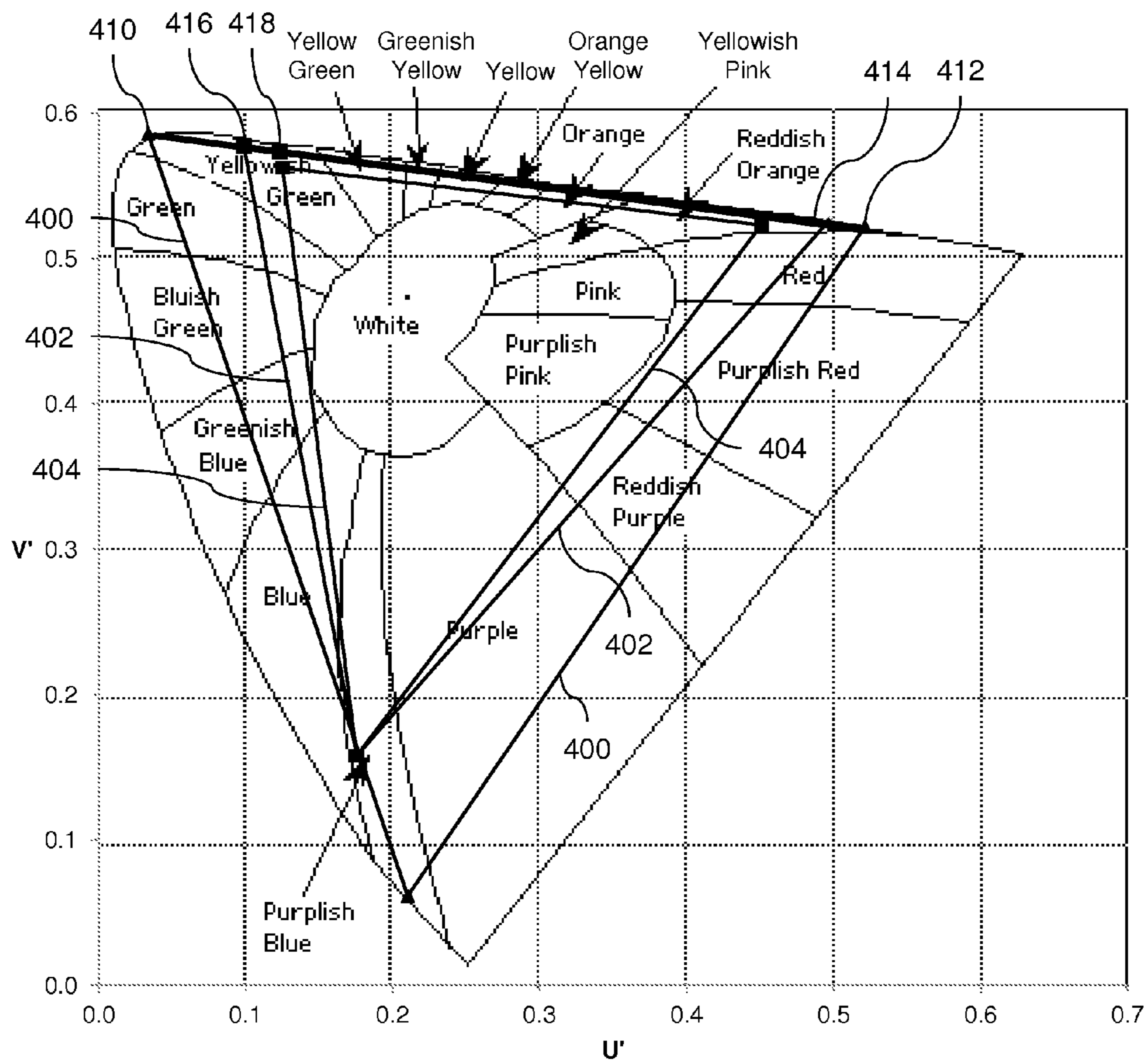

FIG. 4

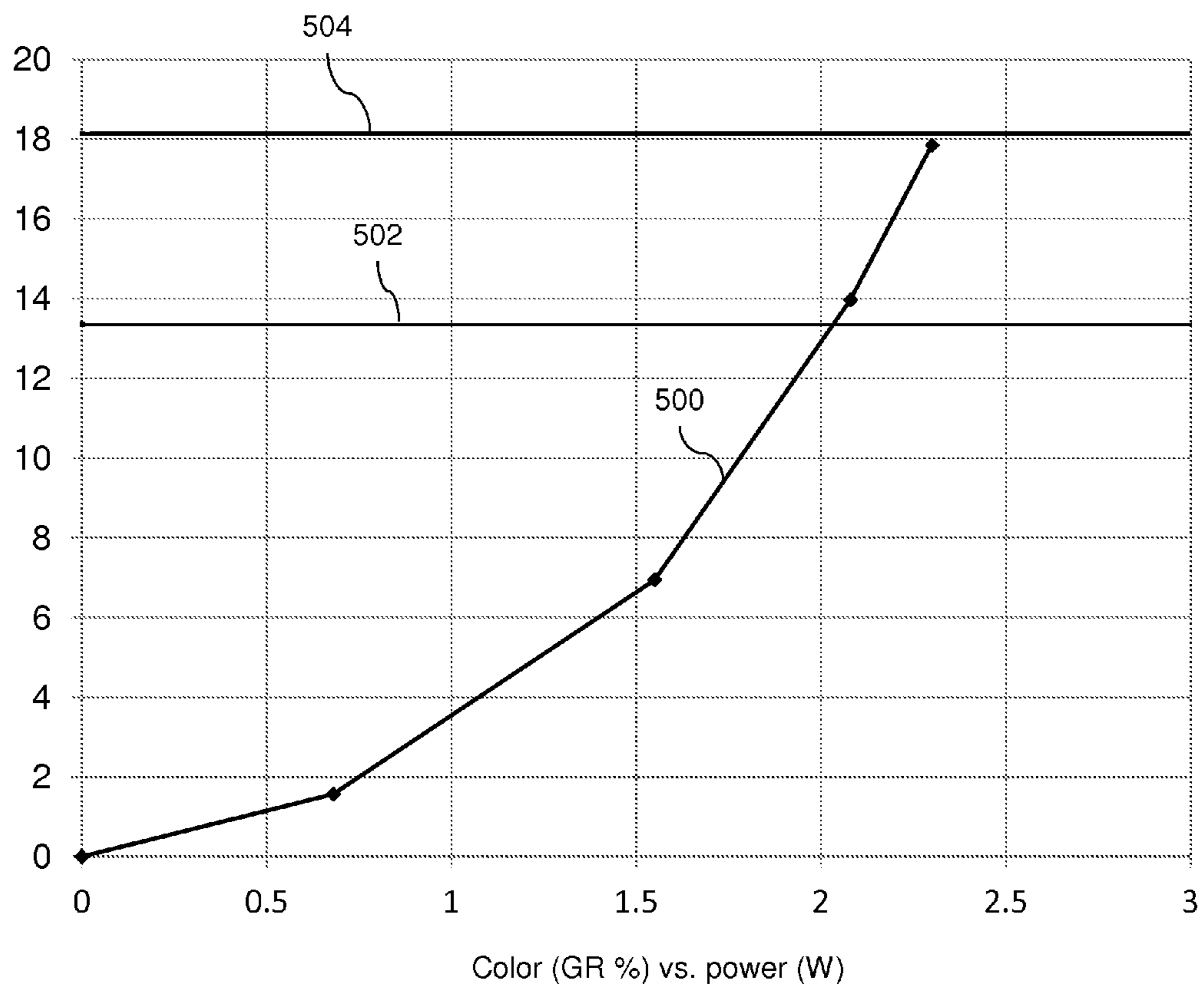

FIG. 5

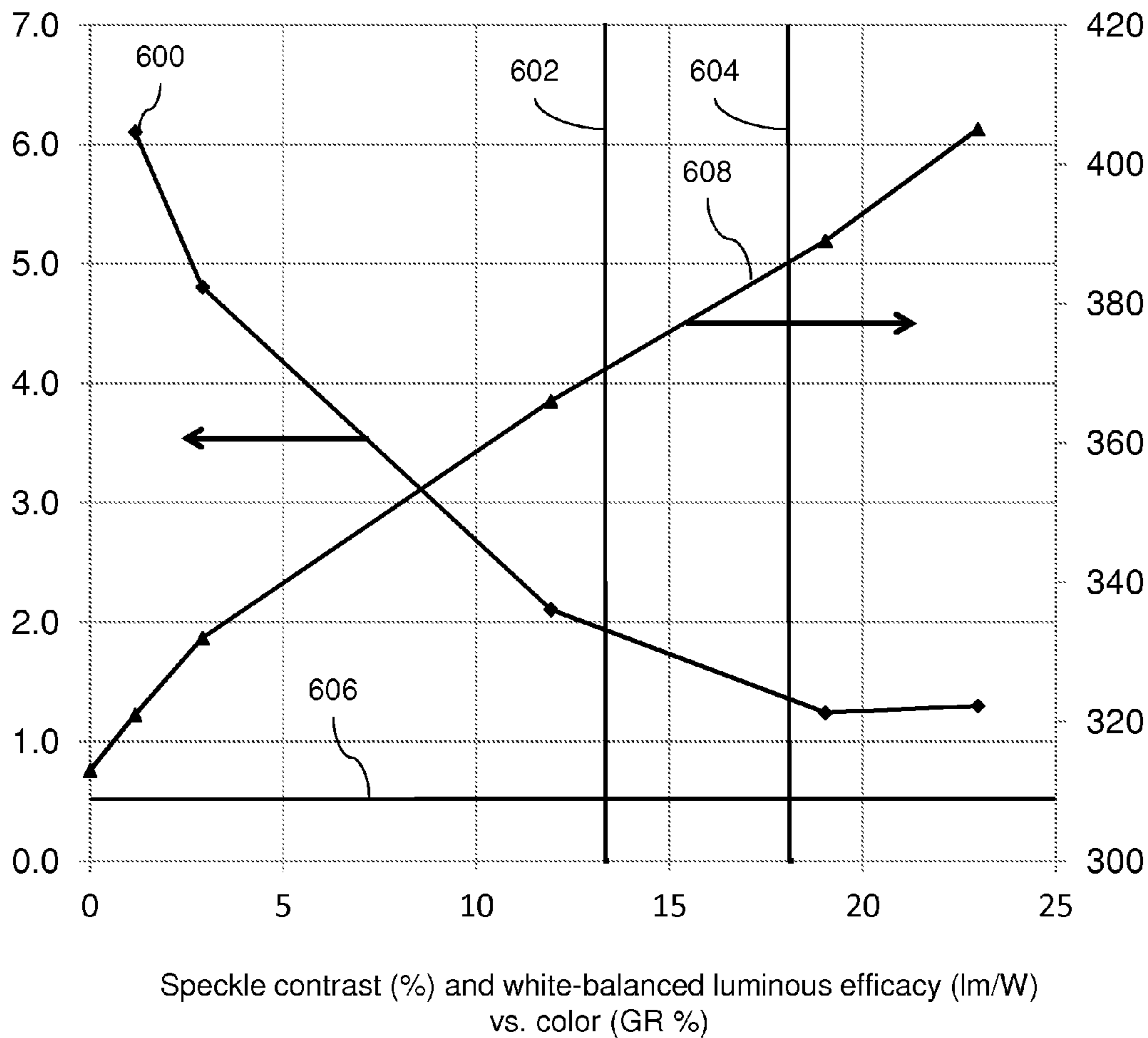

FIG. 6

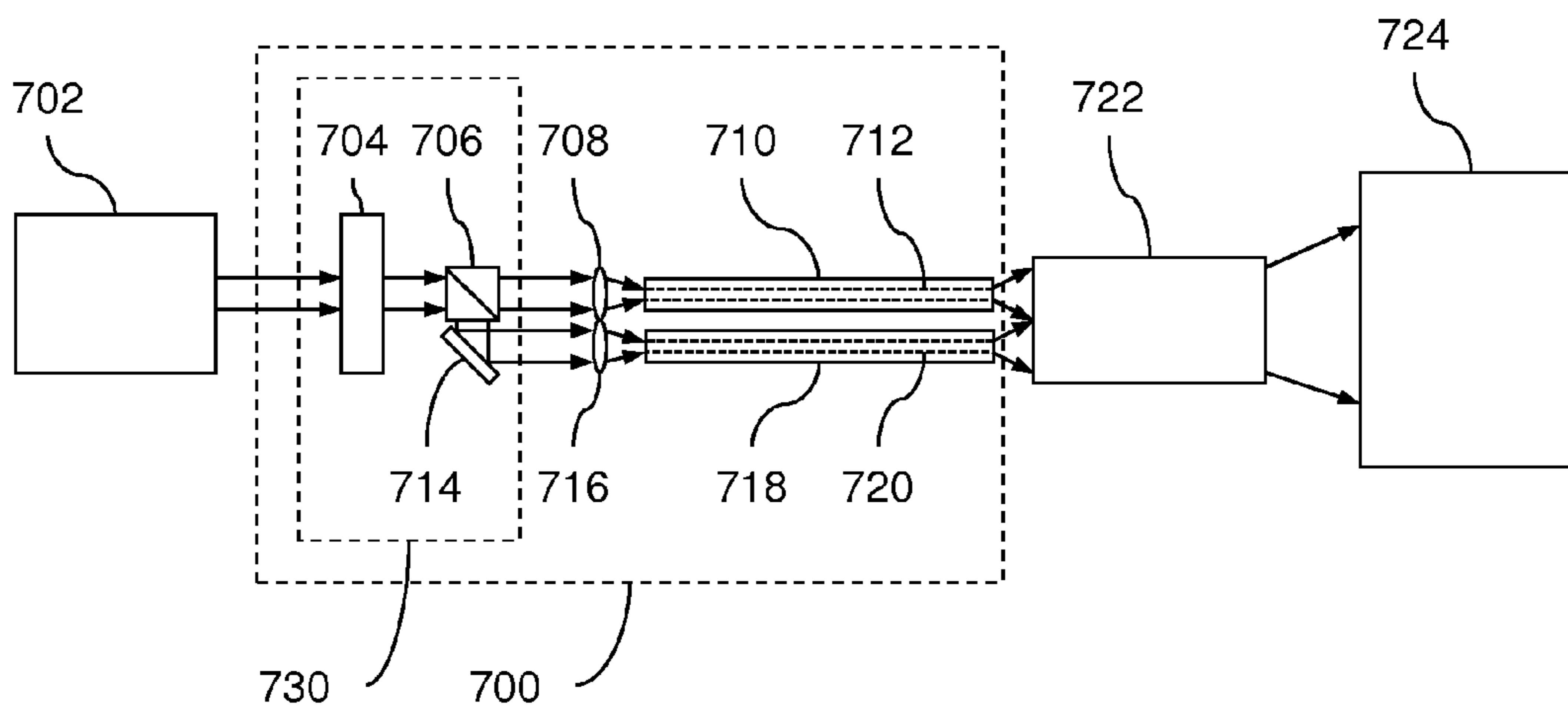
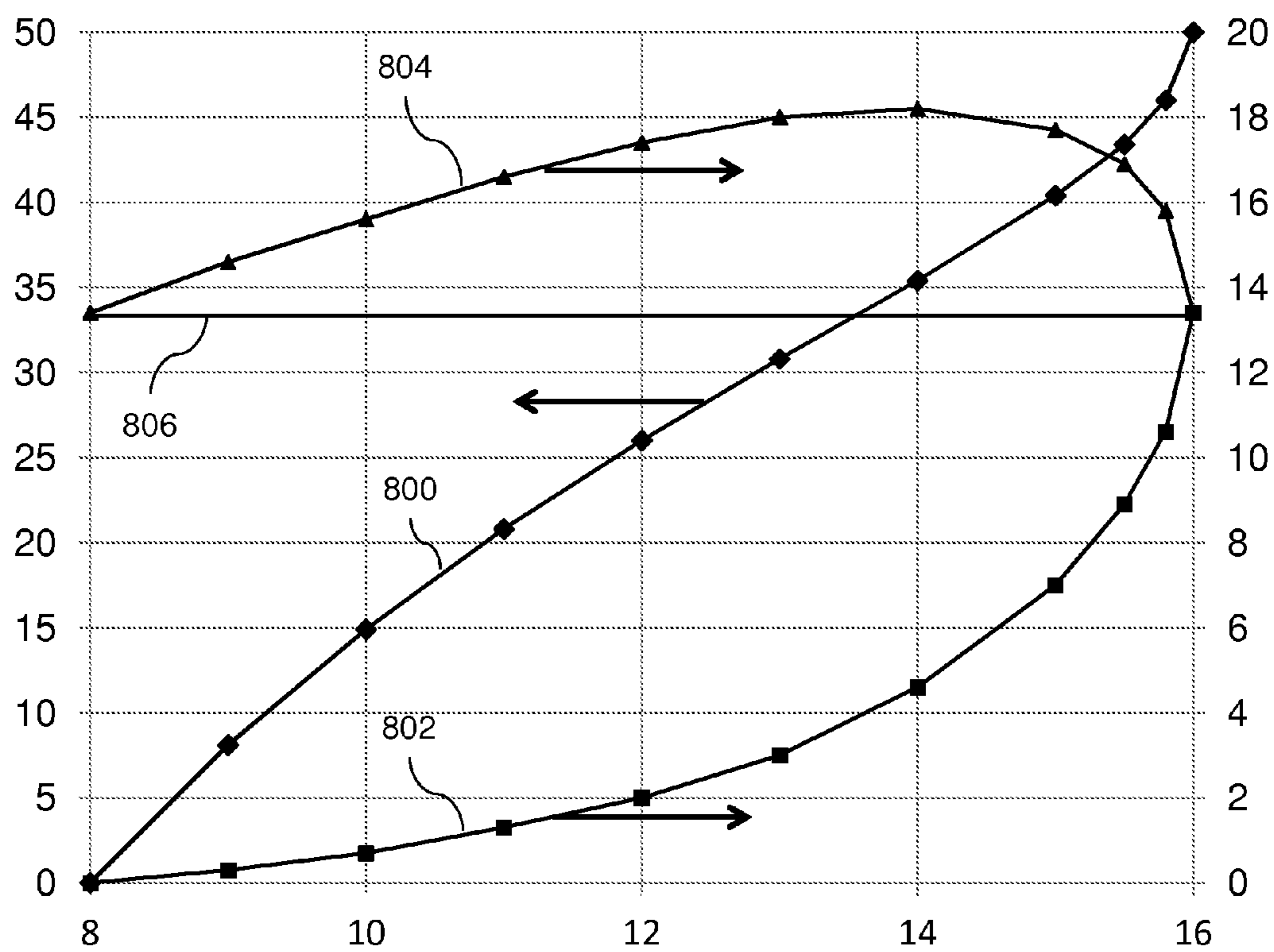

FIG. 7



Power in first fiber (%), color out of first fiber (GR %), and color out of second fiber (GR %) vs. total power (W)

FIG. 8

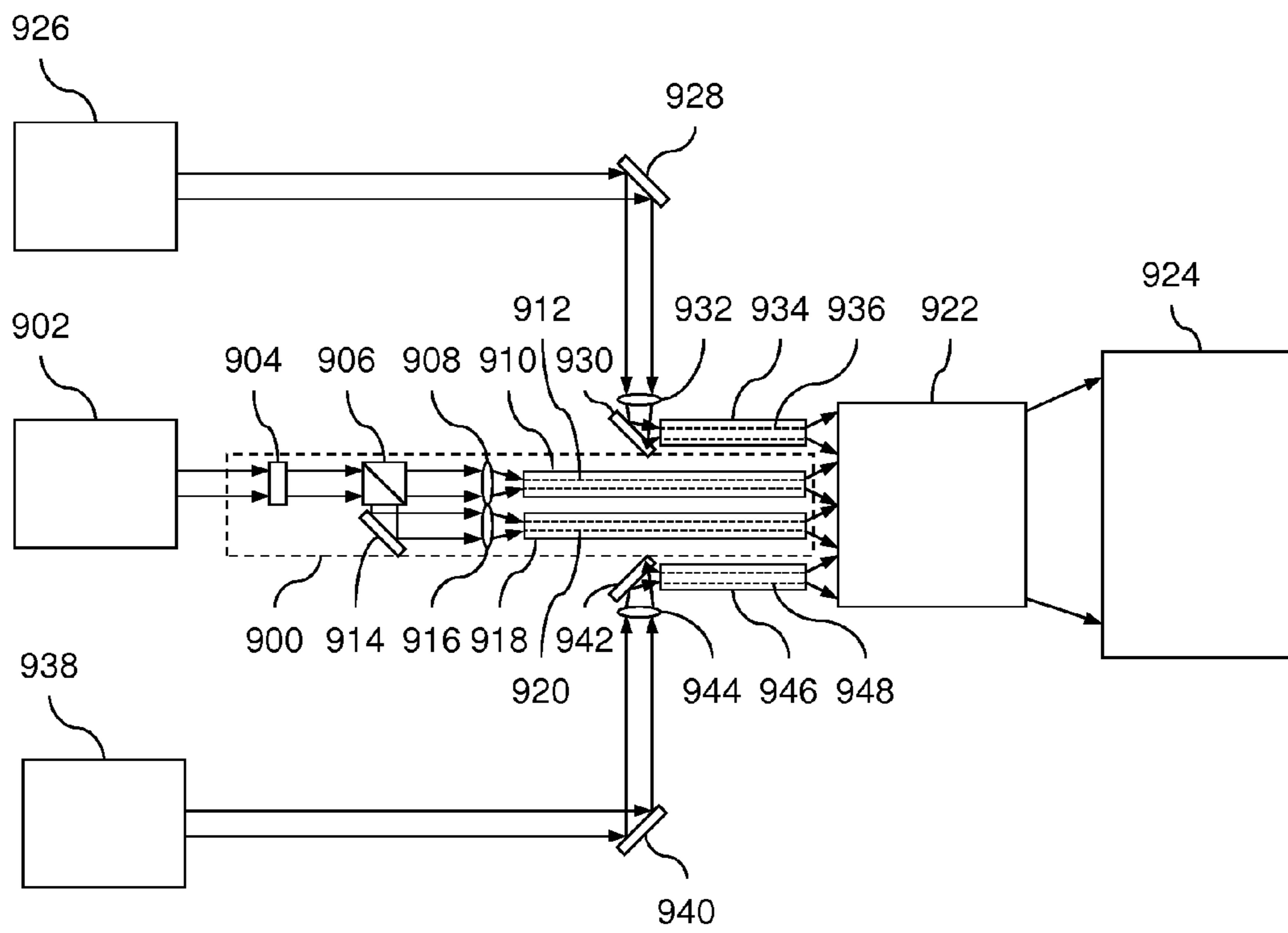

FIG. 9

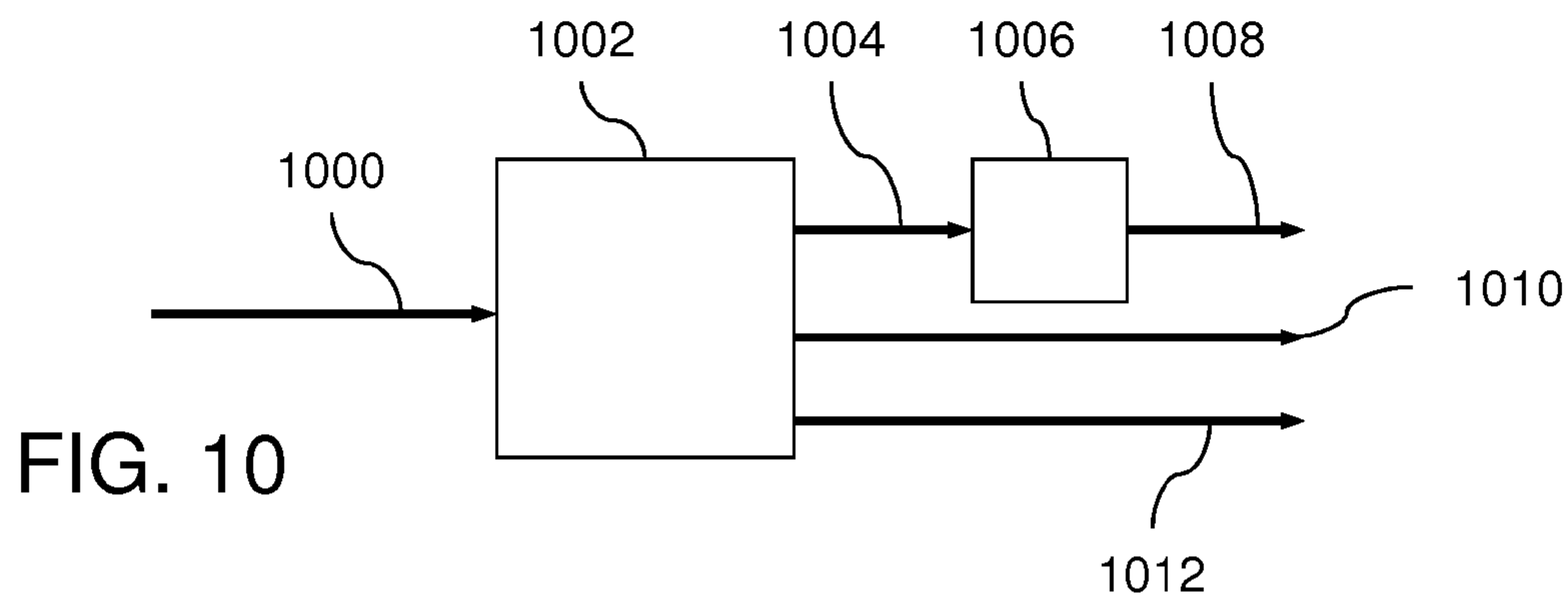

FIG. 10

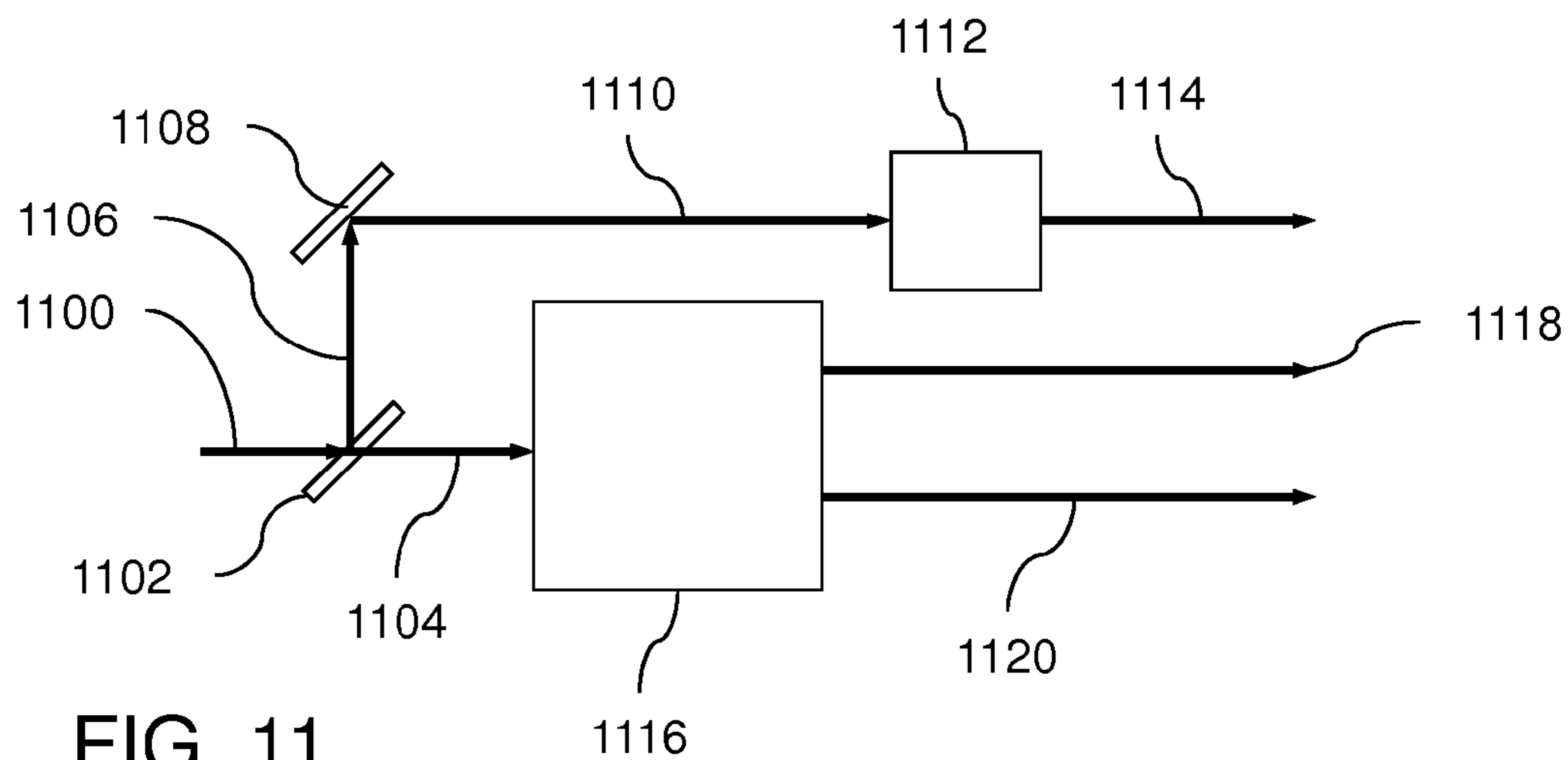

FIG. 11

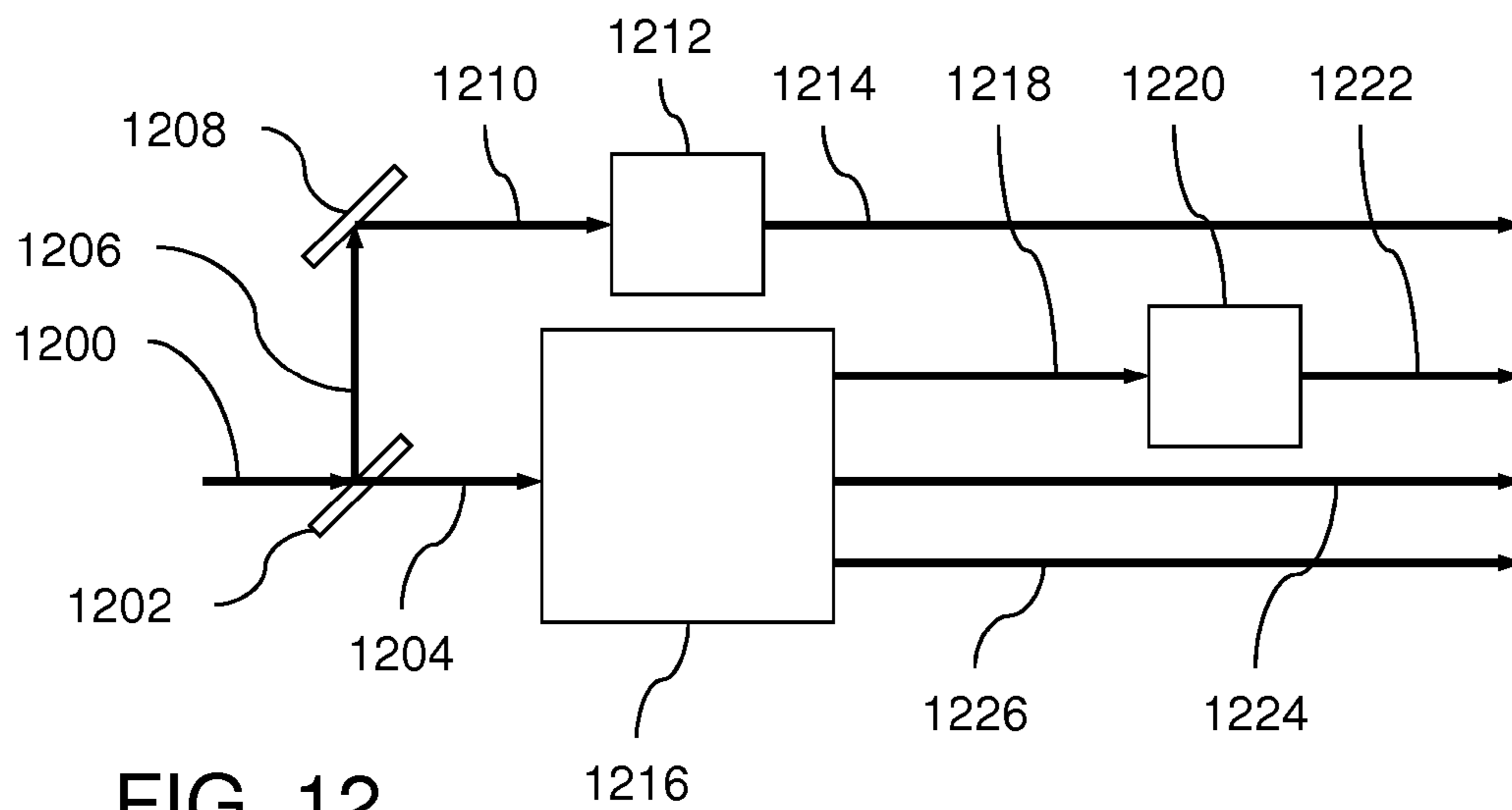

FIG. 12

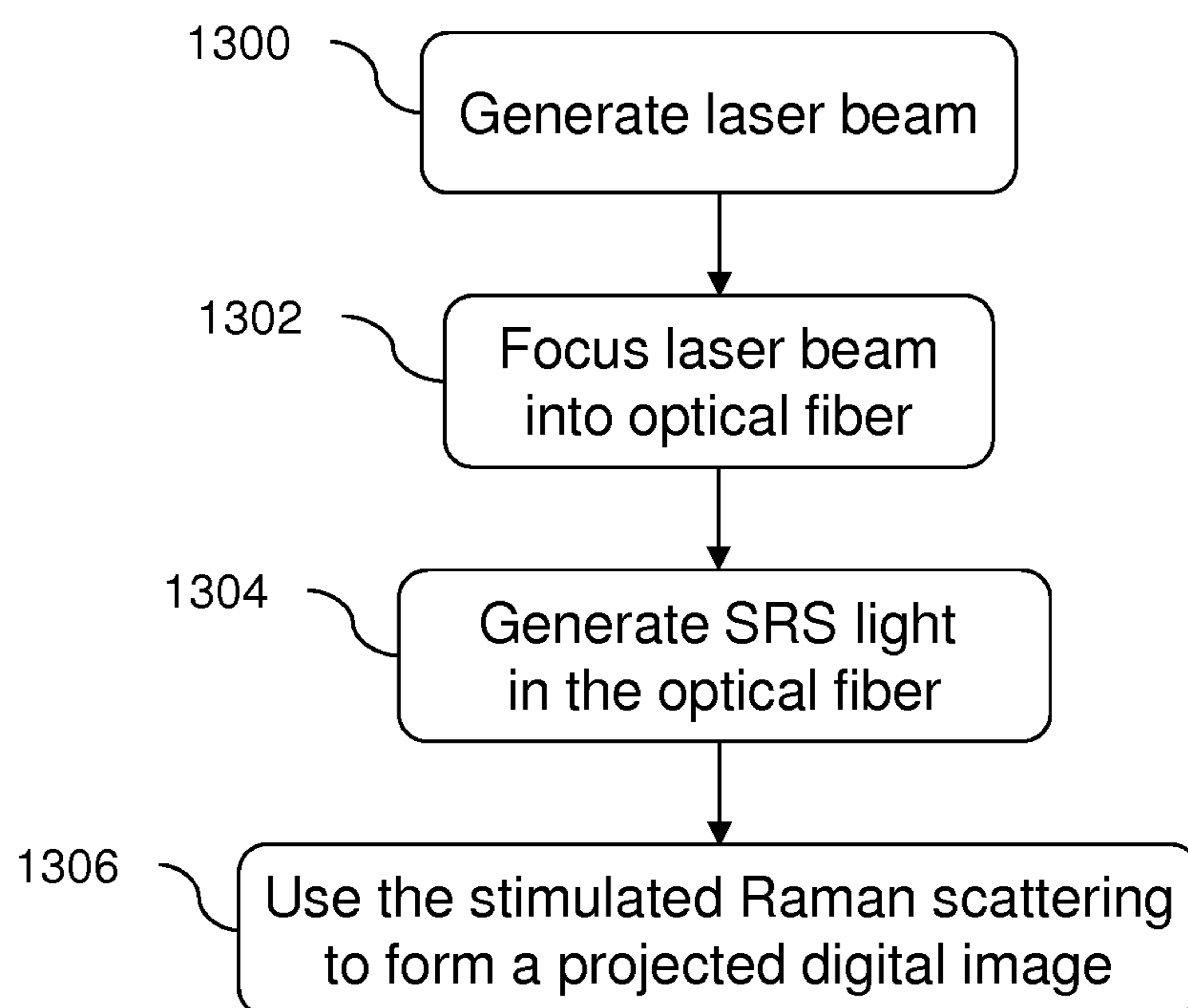

FIG. 13

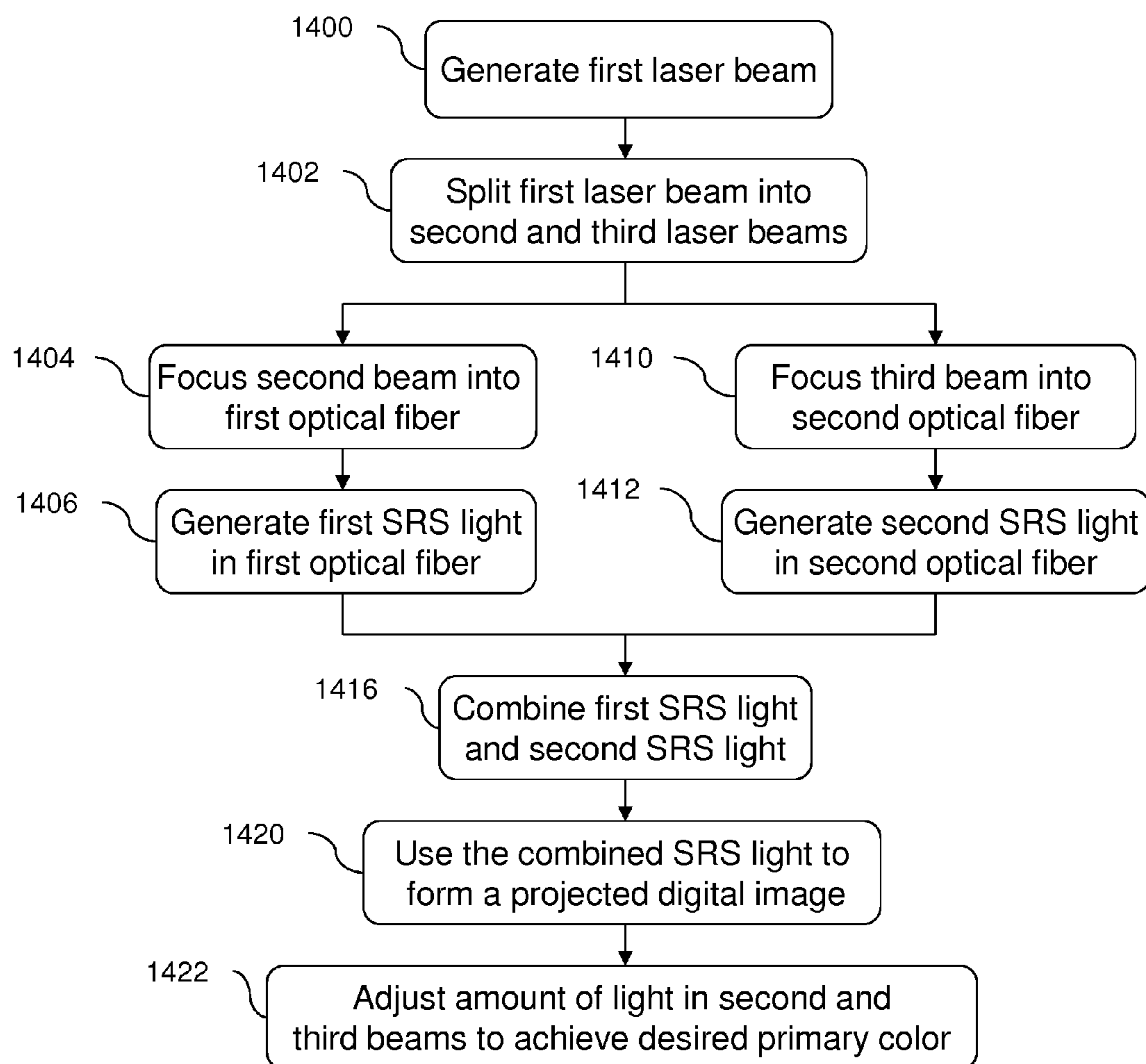

FIG. 14

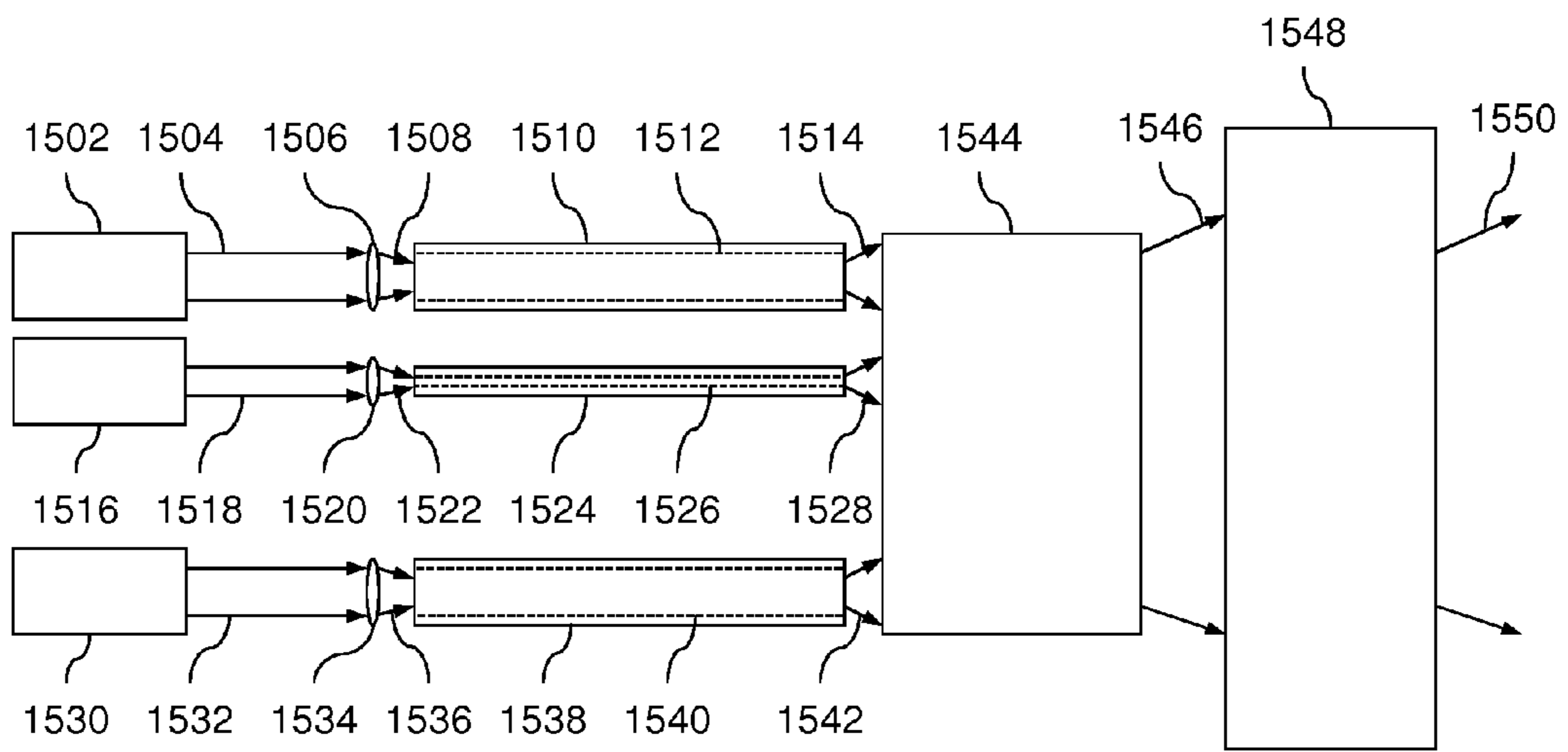

FIG. 15

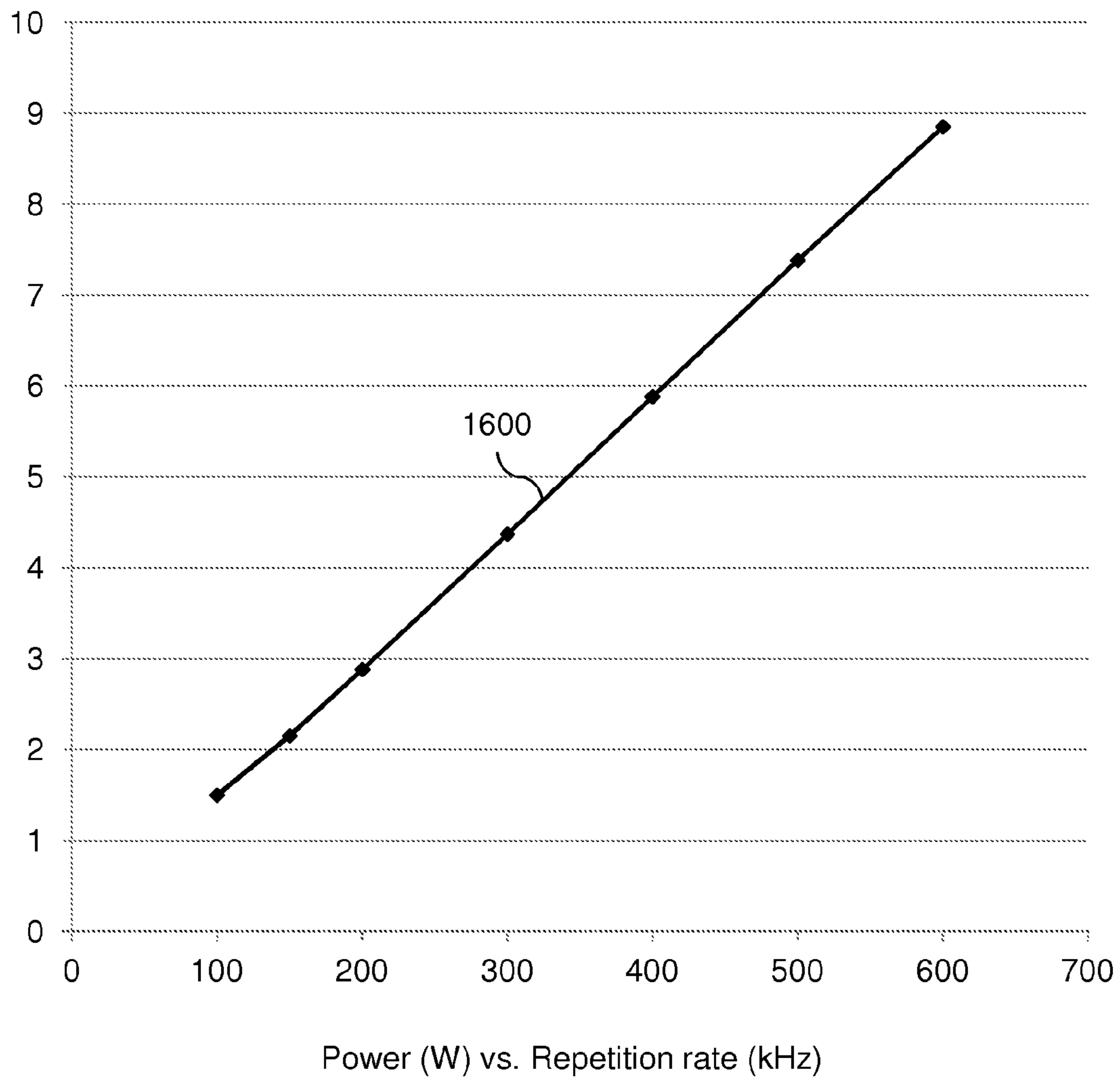
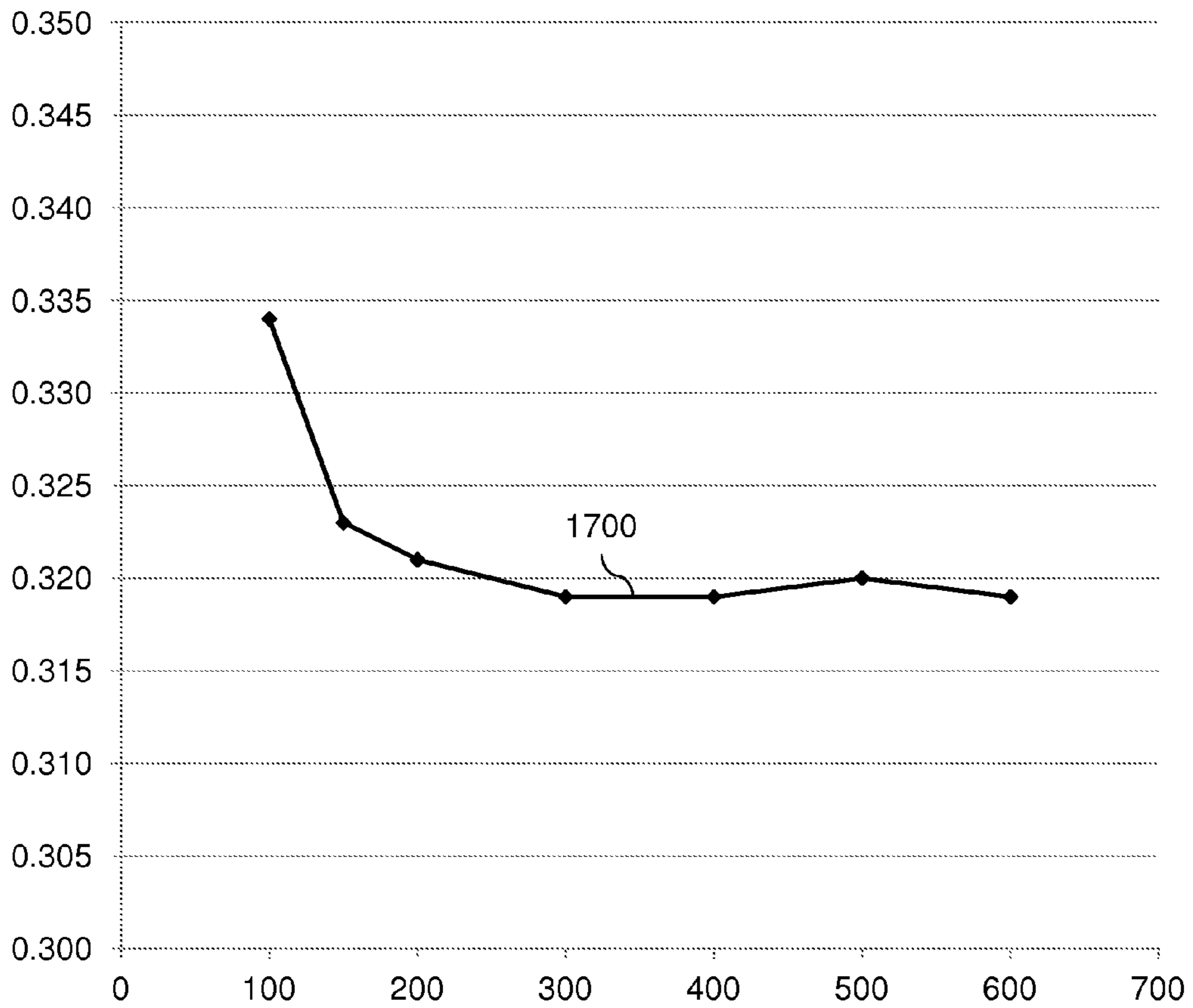

FIG. 16



Color (x-value) vs. Repetition rate (kHz)

FIG. 17

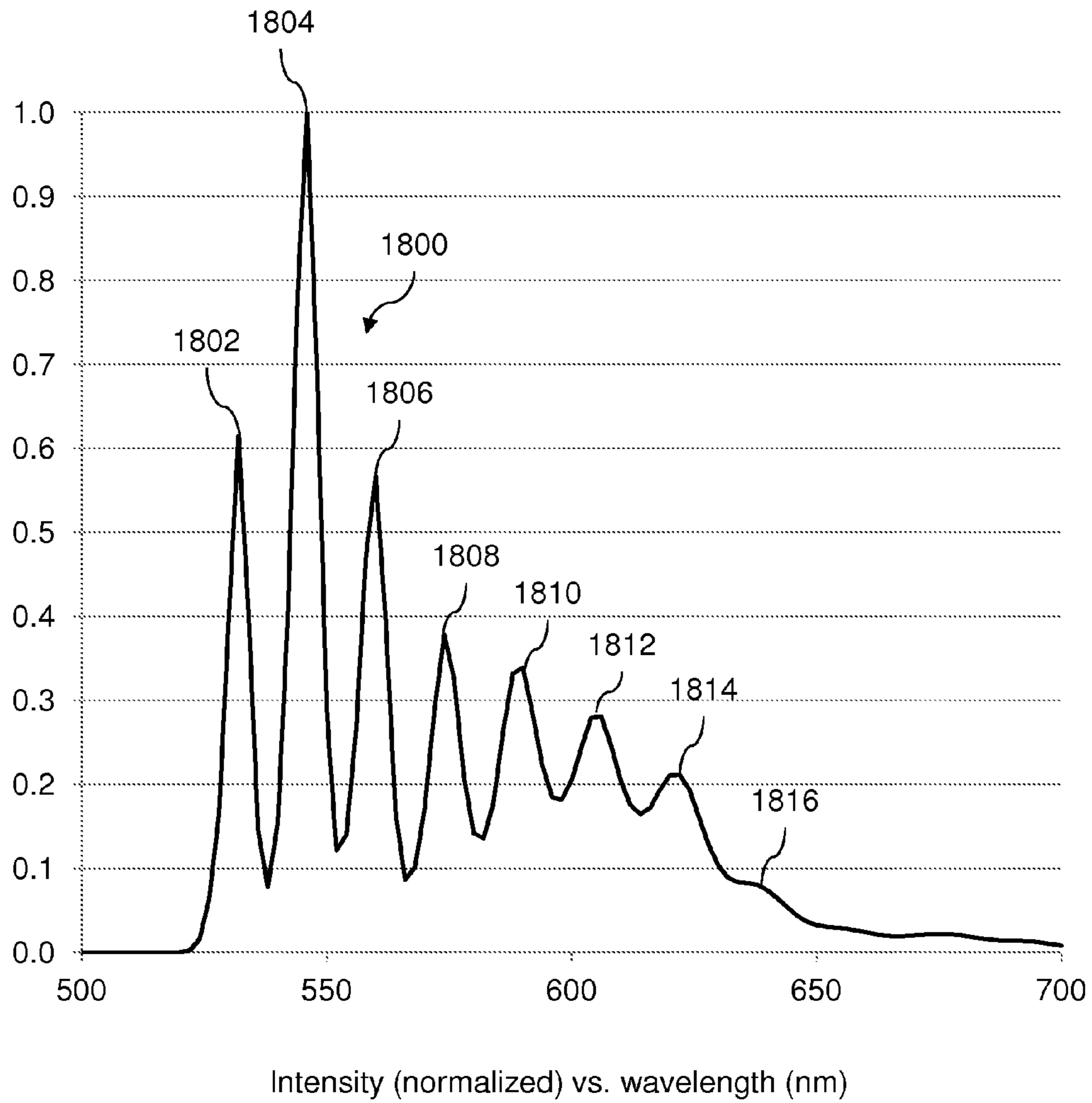

FIG. 18

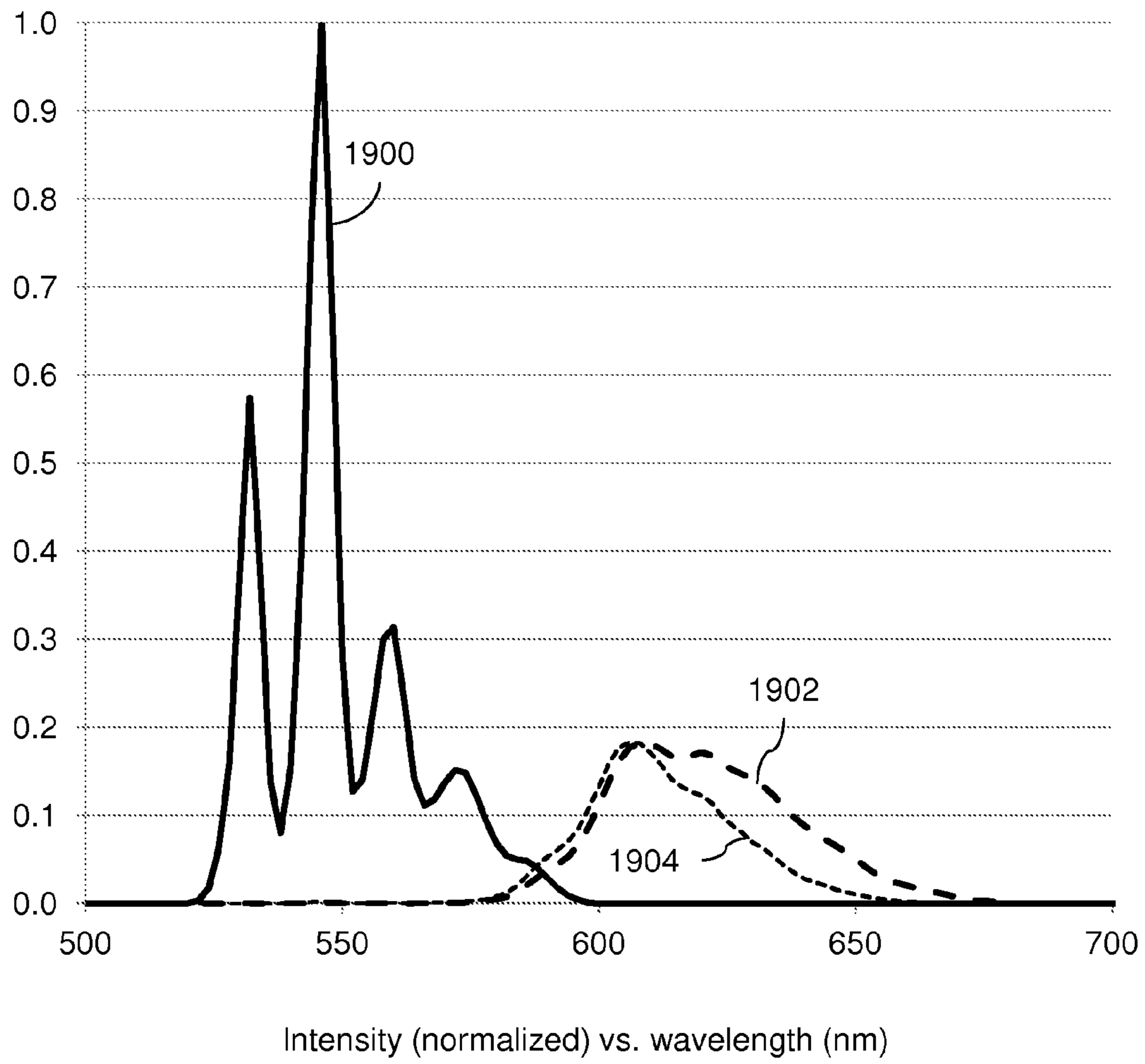

FIG. 19

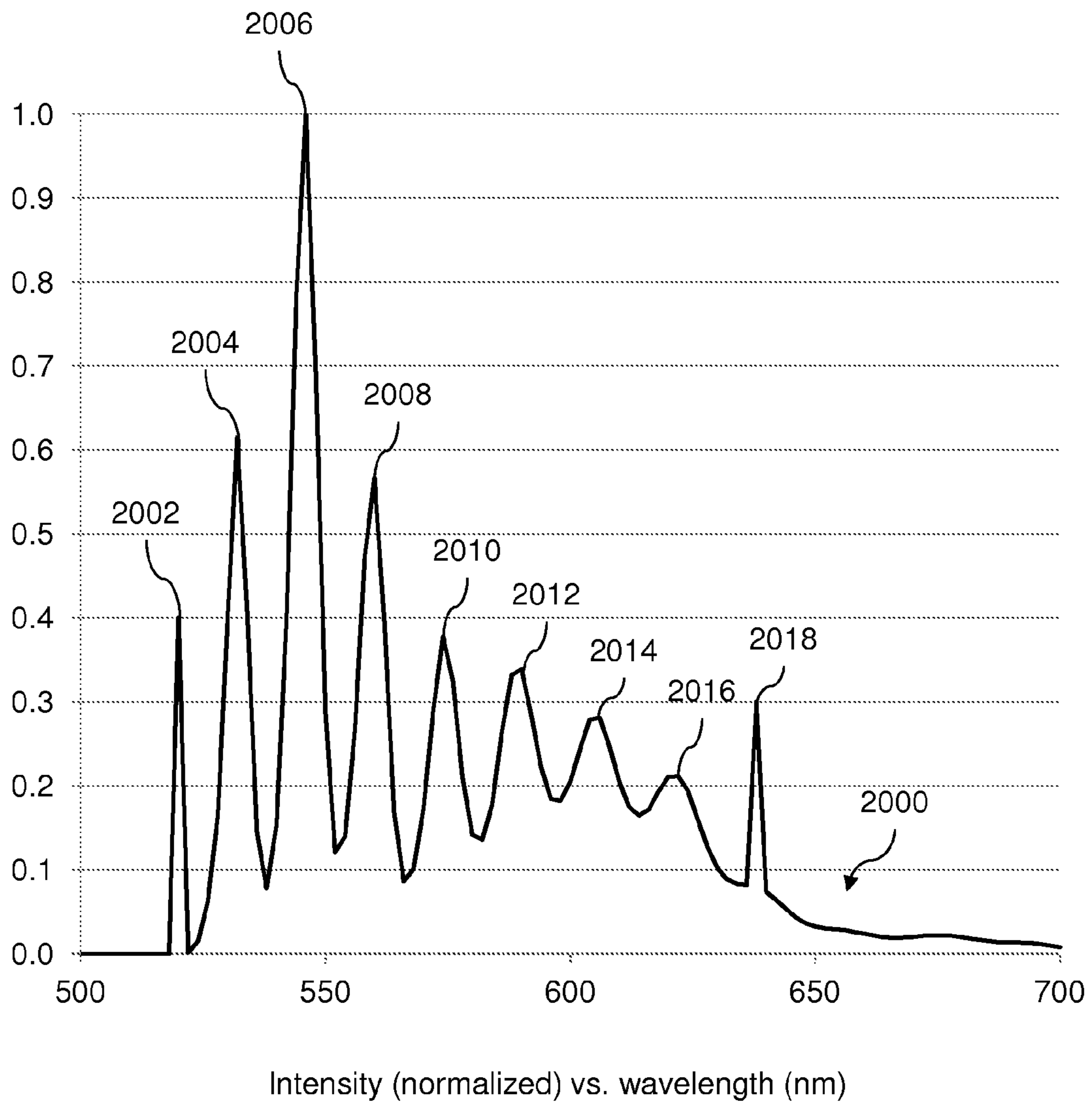

FIG. 20

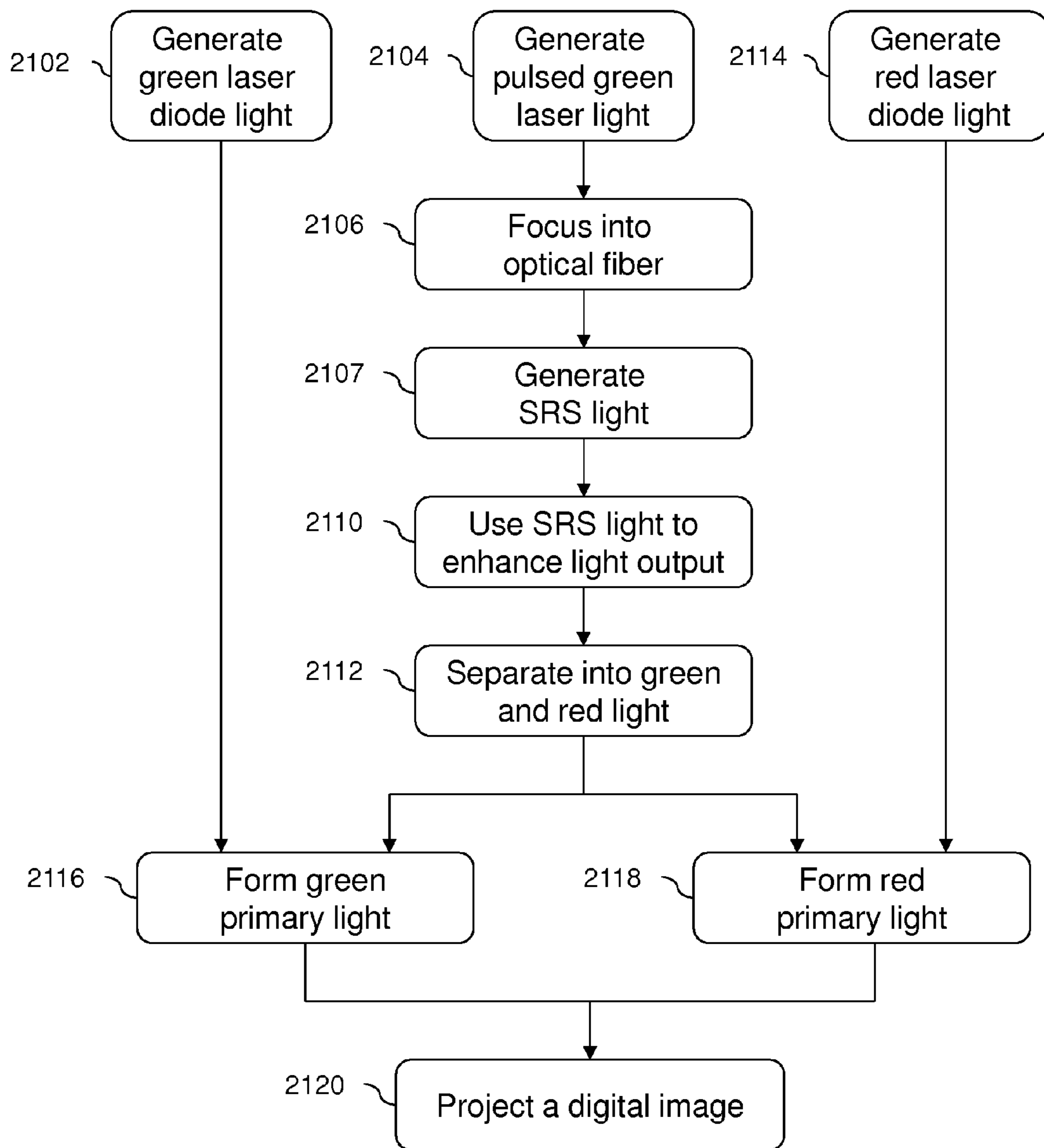

FIG. 21

1

GREEN AND RED DESPECKLING

BACKGROUND OF THE INVENTION

There are many advantages for using laser light sources to illuminate digital projection systems, but the high coherence of laser light tends to produce undesirable speckle in the viewed image. Known despeckling methods generally fall into the categories of polarization diversity, angle diversion, and wavelength diversity. In the laser projection industry, there has been a long-felt need for more effective despeckling methods.

SUMMARY OF THE INVENTION

In general, in one aspect, an optical apparatus that includes a pulsed laser, a green laser diode assembly, and an optical fiber. The pulsed laser light is focused into the optical fiber. The optical fiber generates stimulated Raman scattering light that enhances an aspect of the light output from the optical fiber. The light output from the optical fiber is separated into green light and red light. The green laser diode assembly and the green light from the fiber are combined to make the green primary light of a projected digital image. The red light output from the fiber makes the red primary light of the same projected digital image.

Implementations may include one or more of the following features. The aspect of the light output of the optical fiber may color or speckle level. There may also be a red laser diode assembly and it may be combined with the red light from the optical fiber to make the red primary light. The brightness of the red light from the fiber may be greater than 20% of the brightness of the red primary light. The photopically-weighted full-width-half-maximum bandwidth of the red primary light may be greater than 15 nm. The pulse repetition rate may be used to control the brightness of the green primary light. The green primary light may be held at constant color. The pulsed green laser may have a wavelength of 532 nm. The pulsed laser may be a fiber laser. The pulse repetition rate may be greater than 280 kHz.

In general, in one aspect, an image projection method that includes the steps of generating green laser light from a pulsed laser, generating green laser light from a green laser diode assembly, focusing the pulsed green laser light into an optical fiber, generating stimulated Raman scattering light in the optical fiber, using the stimulated Raman scattering light to enhance an aspect of the light output of the optical fiber, separating the light output from the optical fiber into green light and red light, combining the green light from the fiber and the green light from the laser diode assembly to make green primary light, using the red light from the fiber to make red primary light, and using the green primary light and the red primary light to project a digital image.

Implementations may include one or more of the following features. The aspect of the light output of the optical fiber may color or speckle level. There may also be a step of generating a red light from a red laser diode assembly and combining with the red light from the optical fiber with the red light from the red laser diode assembly to make red primary light. The photopically-weighted full-width-half-maximum bandwidth of the red primary light may be greater than 15 nm. The pulse repetition rate may be used to control the brightness of the green primary light. The green primary light may be held at a constant color. The pulsed laser may be a fiber laser. The pulse repetition rate may be greater than 280 kHz.

2

BRIEF DESCRIPTION OF THE SEVERAL VIEWS OF THE DRAWING

FIG. 1 is a graph of stimulated Raman scattering at moderate power;

FIG. 2 is a graph of stimulated Raman scattering at high power;

FIG. 3 is a top view of a laser projection system with a despeckling apparatus;

FIG. 4 is a color chart of a laser-projector color gamut compared to the Digital Cinema Initiative (DCI) and Rec. 709 standards;

FIG. 5 is a graph of color vs. power for a despeckling apparatus;

FIG. 6 is a graph of speckle contrast and luminous efficacy vs. color for a despeckling apparatus;

FIG. 7 is a top view of a laser projection system with an adjustable despeckling apparatus;

FIG. 8 is a graph of percent power into the first fiber, color out of the first fiber, and color out of the second fiber vs. total power for an adjustable despeckling apparatus;

FIG. 9 is a top view of a three-color laser projection system with an adjustable despeckling apparatus;

FIG. 10 is a block diagram of a three-color laser projection system with despeckling of light taken after an OPO;

FIG. 11 is a block diagram of a three-color laser projection system with despeckling of light taken before an OPO;

FIG. 12 is a block diagram of a three-color laser projection system with despeckling of light taken before and after an OPO;

FIG. 13 is a flowchart of a despeckling method;

FIG. 14 is a flowchart of an adjustable despeckling method;

FIG. 15 is a top view of a laser projection system with a pulsed green laser, a green laser diode assembly, and a red laser diode assembly;

FIG. 16 is a graph of power vs. repetition rate for a pulsed green laser;

FIG. 17 is a graph of color vs. repetition rate for a pulsed green laser;

FIG. 18 is a graph of intensity vs. wavelength for a despeckled pulsed green laser;

FIG. 19 is a graph of intensity vs. wavelength for a despeckled pulsed green laser formed into green and red primaries;

FIG. 20 is a graph of intensity vs. wavelength for a despeckled pulsed green laser with green laser diodes and red laser diodes;

FIG. 21 is a flowchart of a despeckling method that uses pulsed green laser light, green diode laser light, and red diode laser light.

DETAILED DESCRIPTION

Raman gas cells using stimulated Raman scattering (SRS) have been used to despeckle light for the projection of images as described in U.S. Pat. No. 5,274,494. SRS is a non-linear optical effect where photons are scattered by molecules to become lower frequency photons. A thorough explanation of SRS is found in Nonlinear Fiber Optics by Govind Agrawal, Academic Press, Third Edition, pages 298-354. FIG. 1 shows a graph of stimulated Raman scattering output from an optical fiber at a moderate power which is only slightly above the threshold to produce SRS. The x-axis represents wavelength in nanometers (nm) and the y-axis represents intensity on a logarithmic scale in dBm normalized to the highest peak. First peak **100** at 523.5 nm

is light which is not Raman scattered. The spectral bandwidth of first peak **100** is approximately 0.1 nm although the resolution of the spectral measurement is 1 nm, so the width of first peak **100** cannot be resolved in FIG. 1. Second peak **102** at 536.5 nm is a peak shifted by SRS. Note the lower intensity of second peak **102** as compared to first peak **100**. Second peak **102** also has a much larger bandwidth than first peak **100**. The full-width half-maximum (FWHM) bandwidth of second peak **102** is approximately 2 nm as measured at points which are -3 dBm down from the maximum value. This represents a spectral broadening of approximately 20 times compared to first peak **100**. Third peak **104** at 550 nm is still lower intensity than second peak **102**. Peaks beyond third peak **104** are not seen at this level of power.

Nonlinear phenomenon in optical fibers can include self-phase modulation, stimulated Brillouin Scattering (SBS), four wave mixing, and SRS. The prediction of which nonlinear effects occur in a specific fiber with a specific laser is complicated and not amenable to mathematical modeling, especially for multimode fibers. SBS is usually predicted to start at a much lower threshold than SRS and significant SBS reflection will prevent the formation of SRS. One possible mechanism that can allow SRS to dominate rather than other nonlinear effects, is that the mode structure of a pulsed laser may form a large number closely-spaced peaks where each peak does not have enough optical power to cause SBS.

FIG. 2 shows a graph of stimulated Raman scattering at higher power than in FIG. 1. The x-axis represents wavelength in nanometers and the y-axis represents intensity on a logarithmic scale in dBm normalized to the highest peak. First peak **200** at 523.5 nm is light which is not Raman scattered. Second peak **202** at 536.5 nm is a peak shifted by SRS. Note the lower intensity of second peak **202** as compared to first peak **200**. Third peak **204** at 550 nm is still lower intensity than second peak **202**. Fourth peak **206** at 564 nm is lower than third peak **204**, and fifth peak **208** at 578 nm is lower than fourth peak **206**. At the higher power of FIG. 2, more power is shifted into the SRS peaks than in the moderate power of FIG. 1. In general, as more power is put into the first peak, more SRS peaks will appear and more power will be shifted into the SRS peaks. In the example of FIGS. 1 and 2, the spacing between the SRS peaks is approximately 13 to 14 nm. As can be seen in FIGS. 1 and 2, SRS produces light over continuous bands of wavelengths which are capable of despeckling by the mechanism of wavelength diversity. Strong despeckling can occur to the point where the output from an optical fiber with SRS shows no visible speckle under most viewing circumstances. Maximum and minimum points for speckle patterns are a function of wavelength, so averaging over more wavelengths reduces speckle. A detailed description of speckle reduction methods can be found in *Speckle Phenomena in Optics*, by Joseph W. Goodman, Roberts and Company Publishers, 2007, pages 141-186.

FIG. 3 shows a top view of a laser projection system with a despeckling apparatus based on SRS in an optical fiber. Laser light source **302** illuminates light coupling system **304**. Light coupling system **304** illuminates optical fiber **306** which has core **308**. Optical fiber **306** illuminates homogenizing device **310**. Homogenizing device **310** illuminates digital projector **312**. Illuminating means making, passing, or guiding light so that the part which is illuminated utilizes light from the part which illuminates. There may be additional elements not shown in FIG. 3 which are between the parts illuminating and the parts being illuminated. Light coupling system **304** and optical fiber **306** with core **308**

form despeckling apparatus **300**. Laser light source **302** may be a pulsed laser that has high enough peak power to produce SRS in optical fiber **306**. Light coupling system **304** may be one lens, a sequence of lenses, or other optical components designed to focus light into core **308**. Optical fiber **306** may be an optical fiber with a core size and length selected to produce the desired amount of SRS. Homogenizing device **310** may be a mixing rod, fly's eye lens, diffuser, or other optical component that improves the spatial uniformity of the light beam. Digital projector **312** may be a projector based on digital micromirror (DMD), liquid crystal device (LCD), liquid crystal on silicon (LCOS), or other digital light valves. Additional elements may be included to further guide or despeckle the light such as additional lenses, diffusers, vibrators, or optical fibers.

For standard fused-silica fiber with a numerical aperture of 0.22, the core size may be 40 micrometers diameter and the length may be 110 meters when the average input power is 3 watts at 523.5 nm. For higher or lower input powers, the length and/or core size may be adjusted appropriately. For example, at higher power, the core size may be increased or the length may be decreased to produce the same amount of SRS as in the 3 watt example. FIG. 1 shows the spectral output of a standard fused-silica fiber with a numerical aperture of 0.22, core size of 40 micrometers diameter and length of 110 meters when the average input power is 2 watts at 523.5 nm. FIG. 2 shows the output of the same system when the average input power is 4 watts. In both cases, the pulsed laser is a Q-switched, frequency-doubled neodymium-doped yttrium lithium fluoride (Nd:YLF) laser which is coupled into the optical fiber with a single aspheric lens that has a focal length of 18.4 mm. Alternatively, a frequency-doubled neodymium-doped yttrium aluminum garnet (Nd:YAG) laser may be used which has an optical output wavelength of 532 nm. The examples of average input powers in this specification are referenced to laser pulses with a pulse width of 50 ns and a frequency of 16.7 kHz.

FIG. 4 shows a color chart of a laser-projector color gamut compared to the DCI and Rec. 709 standards. The x and y axes of FIG. 4 represent the u' and v' coordinates of the Commission Internationale de l'Eclairage (CIE) 1976 color space. Each color gamut is shown as a triangle formed by red, green, and blue primary colors that form the corners of the triangle. Other colors of a digital projector are made by mixing various amounts of the three primaries to form the colors inside the gamut triangle. First triangle **400** shows the color gamut of a laser projector with primary colors at 452 nm, 523.5 nm, and 621 nm. Second triangle **402** shows the color gamut of the DCI standard which is commonly accepted for digital cinema in large venues such as movie theaters. Third triangle **404** shows the color gamut of The International Telecommunication Union Radiocommunication (ITU-R) Recommendation 709 (Rec. 709) standard which is commonly accepted for broadcast of high-definition television. Green point **410** is the green primary of a laser projector at 523.5 nm. Red point **412** is the red primary of a laser projector at 621 nm. Line **414** (shown in bold) represents the possible range of colors along the continuum between green point **410** and red point **412**. The colors along line **414** can be obtained by mixing yellow, orange, and red colors with the primary green color. The more yellow, orange, or red color, the more the color of the green is pulled along line **414** towards the red direction. For the purposes of this specification, "GR color" is defined to be the position along line **414** in percent. For example, pure green at green point **410** has a GR (green-red) color of 0%. Pure red at red

5

point **412** has a GR color of 100%. DCI green point **416** is at $u'=0.099$ and $v'=0.578$ and has a GR color of 13.4% which means that the distance between green point **410** and DCI green point **416** is 13.4% of the distance between green point **410** and red point **412**. When the Rec. 709 green point of third triangle **404** is extrapolated to line **414**, the resultant Rec. 709 green point **418** has a GR color of 18.1%. The concept of GR color is a way to reduce two-dimensional u' v' color as shown in the two-dimensional graph of FIG. 4 to one-dimensional color along line **414** so that other variables can be easily plotted in two dimensions as a function of GR color. In the case of a primary green at 523.5 nm experiencing SRS, the original green color is partially converted to yellow, orange, and red colors, which pull the resultant combination color along line **414** and increase the GR %. Although the DCI green point may be the desired target for the green primary, some variation in the color may be allowable. For example, a variation of approximately ± 0.01 in the u' and v' values may be acceptable.

FIG. 5 shows a graph of color vs. power for a despeckling apparatus. The x-axis represents power in watts which is output from the optical fiber of a despeckling apparatus such as the one shown in FIG. 3. The y-axis represents the GR color in percent as explained in FIG. 4. The optical fiber has the same parameters as in the previous example (core diameter of 40 micrometers and length of 110 meters). Curve **500** shows how the color varies as a function of the output power. As the output power increases, the GR color gradually increases. The curve can be fit by the third-order polynomial

$$\text{GR \%} = 1.11p^3 + 0.0787p^2 + 1.71p + 0.0041$$

where “p” is the output power in watts. First line **502** represents the DCI green point at a GR color of 13.4%, and second line **504** represents the Rec. 709 green point at approximately 18.1%. The average power output required to reach the DCI green point is approximately 2.1 W, and the average output power required to reach the Rec. 709 point is approximately 2.3 W.

FIG. 6 shows a graph of speckle contrast and luminous efficacy vs. color for a despeckling apparatus such as the one shown in FIG. 3. The x-axis represents GR color in percent. The left y-axis represents speckle contrast in percent, and the right y-axis represents luminous efficacy in lumens per watt. Speckle contrast is a speckle characteristic that quantitatively represents the amount of speckle in an observed image. Speckle contrast is defined as the standard deviation of pixel intensities divided by the mean of pixel intensities for a specific image. Intensity variations due to other factors such as non-uniform illumination or dark lines between pixels (screen door effect) must be eliminated so that only speckle is producing the differences in pixel intensities. Measured speckle contrast is also dependent on the measurement geometry and equipment, so these should be standardized when comparing measurements. Other speckle characteristics may be mathematically defined in order to represent other features of speckle. In the example of FIG. 6, the measurement of speckle contrast was performed by analyzing the pixel intensities of images taken with a Canon EOS Digital Rebel XTi camera at distance of two screen heights. Automatic shutter speed was used and the iris was fixed at a 3 mm diameter by using a lens focal length of 30 mm and an $f\#$ of 9.0. Additional measurement parameters included an ISO of 100, monochrome data recording, and manual focus. The projector was a Digital Projection Titan that was illuminated with green laser light from a Q-switched, frequency-doubled, Nd:YLF laser which is

6

coupled into a 40-micrometer core, 110 meter, optical fiber with a single aspheric lens that has a focal length of 18.4 mm. Improved uniformity and a small amount of despeckling was provided by a rotating diffuser at the input to the projector.

For the speckle-contrast measurement parameters described above, 1% speckle is almost invisible to the un-trained observer with normal visual acuity when viewing a 100% full-intensity test pattern. Conventional low-gain screens have sparkle or other non-uniformities that can be in the range of 0.1% to 1% when viewed with non-laser projectors. For the purposes of this specification, 1% speckle contrast is taken to be the point where no speckle is observable for most observers under most viewing conditions. 5% speckle contrast is usually quite noticeable to un-trained observers in still images, but is often not visible in moving images.

First curve **600** in FIG. 6 shows the relationship between measured speckle contrast and GR color. As the GR color is increased, the speckle contrast is decreased. Excellent despeckling can be obtained such that the speckle contrast is driven down to the region of no visible speckle near 1%. In the example of FIG. 6, first line **602** represents the DCI green point which has a speckle contrast of approximately 2% and second line **604** represents the Rec. 709 green point which has a speckle contrast of approximately 1%. The speckle contrast obtained in a specific configuration will be a function of many variables including the projector type, laser type, fiber type, diffuser type, and speckle-contrast measurement equipment. Third line **606** represents the minimum measurable speckle contrast for the system. The minimum measurable speckle contrast was determined by illuminating the screen with a broadband white light source and is equal to approximately 0.3% in this example. The minimum measurable speckle contrast is generally determined by factors such as screen non-uniformities (i.e. sparkle) and camera limitations (i.e. noise).

Second curve **608** in FIG. 6 shows the relationship between white-balanced luminous efficacy and GR color. The white-balanced luminous efficacy can be calculated from the spectral response of the human eye and includes the correct amounts of red light at 621 nm and blue light at 452 nm to reach the D63 white point. As the GR color is increased in the range covered by FIG. 6 (0% to 25%) the white-balanced luminous efficacy increases almost linearly from approximately 315 lm/w at a GR color of 0% to approximately 370 lm/w at the DCI green and approximately 385 lm/w at the Rec. 709 green point. This increase in luminous efficacy is beneficial to improve the visible brightness and helps compensate for losses that are incurred by adding the despeckling apparatus.

FIG. 7 shows a top view of a laser projection system with an adjustable despeckling apparatus. FIG. 7 incorporates two fibers for despeckling rather than the one fiber used for despeckling in FIG. 3. The despeckling apparatus of FIG. 3 allows tuning of the desired amount of despeckling and color point by varying the optical power coupled into optical fiber **306**. FIG. 7 introduces a new independent variable which is the fraction of optical power coupled into one of the fibers. The balance of the power is coupled into the other fiber. The total power sent through the despeckling apparatus is the sum of the power in each fiber. The additional variable allows the despeckling and color point to be tuned to a single desired operation point for any optical power over a limited range of adjustment.

In FIG. 7, polarized laser light source **702** illuminates rotating waveplate **704**. Rotating waveplate **704** changes the

polarization vector of the light so that it contains a desired amount of light in each of two polarization states. Rotating waveplate **704** illuminates polarizing beamsplitter (PBS) **706**. PBS **706** divides the light into two beams. One beam with one polarization state illuminates first light coupling system **708**. The other beam with the orthogonal polarization state reflects off fold mirror **714** and illuminates second light coupling system **716**. First light coupling system **708** illuminates first optical fiber **710** which has first core **712**. First optical fiber **710** illuminates homogenizing device **722**. Second light coupling system **716** illuminates second optical fiber **718** which has core **720**. Second optical fiber **718** combines with first optical fiber **710** to illuminate homogenizing device **722**. Homogenizing device **722** illuminates projector **724**. Rotating waveplate **704**, PBS **706**, and fold mirror **714** form variable light splitter **730**. Variable light splitter **730**, first light coupling system **708**, second light coupling system **716**, first optical fiber **710** with core **712**, and second optical fiber **718** with core **720** form despeckling apparatus **700**. Laser light source **702** may be a polarized, pulsed laser that has high enough peak power to produce SRS in first optical fiber **710** and second optical fiber **718**. First light coupling system **708** and second light coupling system **716** each may be one lens, a sequence of lenses, or other optical components designed to focus light into first core **712** and second core **720** respectively. First optical fiber **710** and second optical fiber **718** each may be an optical fiber with a core size and length selected to produce the desired amount of SRS. First optical fiber **710** and second optical fiber **718** may be the same length or different lengths and may have the same core size or different core sizes. Additional elements may be included to further guide or despeckle the light such as additional lenses, diffusers, vibrators, or optical fibers.

FIG. **8** shows a graph of power in the first optical fiber, color out of the first optical fiber, and color out of the second optical fiber vs. total power for an adjustable despeckling apparatus of the type shown in FIG. **7**. The x-axis represents total average optical power in watts. The mathematical model used to derive FIG. **8** assumes no losses (such as scatter, absorption, or coupling) so the input power in each fiber is equal to the output power from each fiber. The total optical power equals the sum of the power in the first fiber and the second fiber. The left y-axis represents power in percent, and the right y-axis represents GR color in percent. In the example of FIG. **8**, the target color is the DCI green point (GR color=13.4%). By adjusting the variable light splitter, all points in FIG. **8** maintain the DCI green point for the combined outputs of the two fibers. The two fibers are identical and each has a core diameter and length selected such that they reach the DCI green point at 8 watts of average optical power. The cubic polynomial fit described for FIG. **5** is used for the mathematical simulation of FIG. **8**. First curve **800** represents the power in the first fiber necessary to keep the combined total output of both fibers at the DCI green color point. Line **806** in FIG. **8** represents the DCI green color point at a GR color of 13.4%. At 8 watts of total average power, 0% power into the first fiber and 100% power into the second fiber gives the DCI green point because the second fiber is selected to give the DCI green point. As the total power is increased, the variable light splitter is adjusted so that more power is carried by the first fiber. The non-linear relationship between power and color (as shown in curve **500** of FIG. **5**) allows the combined output of both fibers to stay at the DCI green point while the total power is increased. At the maximum average power of

16 watts, the first fiber has 50% of the total power, the second fiber has 50% of the total power, and each fiber carries 8 watts.

Second curve **802** in FIG. **8** represents the color of the output of the first fiber. Third curve **804** in FIG. **8** represents the color of the output of the second fiber. Third curve **804** reaches a maximum at approximately 14 watts of total average power which is approximately 9 watts of average power in the second fiber. Because 9 watts is larger than the 8 watts necessary to reach DCI green in the second fiber, the GR color of light out of the second fiber is approximately 18% which is higher than the 13.4% for DCI green. As the total average power is increased to higher than 14 watts, the amount of light in the second fiber is decreased. When 16 watts of total average power is reached, each fiber reaches 8 watts of average power. The example of FIG. **8** shows that by adjusting the amount of power in each fiber, the overall color may be held constant at DCI green even though the total average power varies from 8 to 16 watts. Although not shown in FIG. **8**, the despeckling is also held approximately constant over the same power range.

The previous example uses two fibers of equal length, but the lengths may be unequal in order to accomplish specific goals such as lowest possible loss due to scattering along the fiber length, ease of construction, or maximum coupling into the fibers. In an extreme case, only one fiber may be used, so that the second path does not pass through a fiber. Instead of a variable light splitter based on polarization, other types of variable light splitters may be used. One example is a variable light splitter based on a wedged multilayer coating that moves to provide more or less reflection and transmission as the substrate position varies. Mirror coatings patterned on glass can accomplish the same effect by using a dense mirror fill pattern on one side of the substrate and a sparse mirror fill pattern on the other side of the substrate. The variable light splitter may be under software control and feedback may be used to determine the adjustment of the variable light splitter. The parameter used for feedback may be color, intensity, speckle contrast, or any other measurable characteristic of light. A filter to transmit only the Raman-shifted light, only one Raman peaks, or specifically selected Raman peaks may be used with a photo detector. By comparing to the total amount of green light or comparing to the un-shifted green peak, the amount of despeckling may be determined. Other adjustment methods may be used instead of or in addition to the two-fiber despeckler shown in FIG. **7**. For example, variable optical attenuators may be incorporated into the fiber, the numerical aperture of launch into the fiber may be varied, or fiber bend radius may be varied.

The example of FIG. **8** is a mathematical approximation which does not include second order effects such as loss and the actual spectrum of SRS. Operational tests of an adjustable despeckler using two identical fibers according to the diagram in FIG. **7** show that the actual range of adjustability may be approximately 75% larger than the range shown in FIG. **8**.

For a three-color laser projector, all three colors must have low speckle for the resultant full-color image to have low speckle. If the green light is formed from a doubled, pulsed laser and the red and blue light are formed by an optical parametric amplifier (OPO) from the green light, the red and blue light may have naturally low speckle because of the broadening of the red and blue light from the OPO. A despeckling apparatus such as the one described in FIG. **7** may be used to despeckle only the green light. A top view of such a system is shown in FIG. **9**. First laser light source

926 illuminates first fold mirror 928 which illuminates light coupling system 932. Light coupling system 932 illuminates second fold mirror 930. Second fold mirror 930 illuminates optical fiber 934 which has core 936. Optical fiber 934 illuminates homogenizing device 922. Second laser light source 902 illuminates rotating waveplate 904. Rotating waveplate 904 changes the polarization vector of the light so that it contains a desired amount of light in each of two polarization states. Rotating waveplate 904 illuminates PBS 906. PBS 906 divides the light into two beams. One beam with one polarization state illuminates second light coupling system 908. The other beam with the orthogonal polarization state reflects off third fold mirror 914 and illuminates third light coupling system 916. Second light coupling system 908 illuminates second optical fiber 910 which has second core 912. Second optical fiber 910 combines with first optical fiber 934 to illuminate homogenizing device 922. Third light coupling system 916 illuminates third optical fiber 918 which has core 920. Third optical fiber 918 combines with first optical fiber 934 and second optical fiber 910 to illuminate homogenizing device 922. Third laser light source 938 illuminates fourth fold mirror 940 which illuminates fourth light coupling system 944. Fourth light coupling system 944 illuminates fifth fold mirror 942. Fifth fold mirror 942 illuminates optical fiber 946 which has core 948. Fourth optical fiber 946 combines with first optical fiber 934, second optical fiber 910, and third optical fiber 918 to illuminate homogenizing device 922. Homogenizing device 922 illuminates projector 924. Rotating waveplate 904, PBS 906, third fold mirror 914, second light coupling system 908, third light coupling system 916, second optical fiber 910 with core 912, and third optical fiber 918 with core 920 form despeckling apparatus 900. First laser light source 926 may be a red laser, second laser light source 902 may be a green laser, and third laser light source 938 may be a blue laser. First laser light source 926 and third laser light source 938 may be formed by an OPO which operates on light from second laser light source 902. Second laser light source 902 may be a pulsed laser that has high enough peak power to produce SRS in second optical fiber 910 and third optical fiber 918. Additional elements may be included to further guide or despeckle the light such as additional lenses, diffusers, vibrators, or optical fibers.

FIG. 9 shows one color of light in each fiber. Alternatively, more than one color can be combined into a single fiber. For example, red light and blue light can both be carried by the same fiber, so that the total number of fibers is reduced from four to three. Another possibility is to combine red light and one green light in one fiber and combine blue light and the other green light in another fiber so that the total number of fibers is reduced to two.

The despeckling apparatus may operate on light taken before, after, or both before and after an OPO. The optimum location of the despeckling apparatus in the system may depend on various factors such as the amount of optical power available at each stage and the amount of despeckling desired. FIG. 10 shows a block diagram of a three-color laser projection system with despeckling of light taken after an OPO. First beam 1000 enters OPO 1002. OPO 1002 generates second beam 1004, fourth beam 1010, and fifth beam 1012. Second beam 1004 enters despeckling apparatus 1006. Despeckling apparatus 1006 generates third beam 1008. First beam 1000, second beam 1004, and third beam 1008 may be green light. Fourth beam 1010 may be red light, and fifth beam 1012 may be blue light. Despeckling apparatus 1006 may be a fixed despeckler or an adjustable despeckler.

FIG. 11 shows a block diagram of a three-color laser projection system with despeckling of light taken before an OPO. First beam 1100 is divided into second beam 1104 and third beam 1106 by splitter 1102. Third beam 1106 reflects from fold mirror 1108 to create fourth beam 1110. Fourth beam 1110 enters despeckling apparatus 1112. Despeckling apparatus 1112 generates fifth beam 1114. Second beam 1104 enters OPO 1116. OPO 1116 generates sixth beam 1118 and seventh beam 1120. First beam 1100, second beam 1104, third beam 1106, fourth beam 1110, and fifth beam 1114 may be green light. Sixth beam 1118 may be red light, and seventh beam 1120 may be blue light. Splitter 1102 may be a fixed splitter or a variable splitter. Despeckling apparatus 1112 may be a fixed despeckler or an adjustable despeckler.

FIG. 12 shows a block diagram of a three-color laser projection system with despeckling of light taken before and after an OPO. First beam 1200 is divided into second beam 1204 and third beam 1206 by splitter 1202. Third beam 1206 reflects from fold mirror 1208 to create fourth beam 1210. Fourth beam 1210 enters first despeckling apparatus 1212. First despeckling apparatus 1212 generates fifth beam 1214. Second beam 1204 enters OPO 1216. OPO 1216 generates sixth beam 1218, seventh beam 1224, and eighth beam 1226. Sixth beam 1218 enters second despeckling apparatus 1220. Second despeckling apparatus 1220 generates ninth beam 1222. First beam 1200, second beam 1204, third beam 1206, fourth beam 1210, fifth beam 1214, sixth beam 1218, and ninth beam 1222 may be green light. Seventh beam 1224 may be red light, and eighth beam 1226 may be blue light. Splitter 1202 may be a fixed splitter or a variable splitter. First despeckling apparatus 1212 and second despeckling apparatus 1220 may be fixed despecklers or adjustable despecklers.

FIG. 13 shows a despeckling method that corresponds to the apparatus shown in FIG. 3. In step 1300, a laser beam is generated. In step 1302, the laser beam is focused into the core of an optical fiber. In step 1304, SRS light is generated in the optical fiber. In step 1306, the SRS light is used to form a projected digital image. Additional steps such as homogenizing, mixing, splitting, recombining, and further despeckling may also be included.

FIG. 14 shows an adjustable despeckling method that corresponds to the apparatus shown in FIG. 7. In step 1400, a first laser beam is generated. In step 1402, the first laser beam is split into second and third laser beams. In step 1404, the second laser beam is focused into the core of a first optical fiber. In step 1406, first SRS light is generated in the first optical fiber. In step 1410, the third laser beam is focused into the core of a second optical fiber. In step 1412, second SRS light is generated in the second optical fiber. In step 1416, the first SRS light and the second SRS light is combined. In step 1420, the combined SRS light is used to form a projected digital image. In step 1422, the amount of light in the second and third beams is adjusted to achieve a desired primary color. Additional steps such as homogenizing, mixing, further splitting, further recombining, and further despeckling may also be included.

Fibers used to generate SRS in a fiber-based despeckling apparatus may be single mode fibers or multimode fibers. Single mode fibers generally have a core diameter less than 10 micrometers. Multimode fibers generally have a core diameter greater than 10 micrometers. Multimode fibers may typically have core sizes in the range of 20 to 400 micrometers to generate the desired amount of SRS depending on the optical power required. For very high powers, even larger core sizes such as 1000 microns or 1500 microns may experience SRS. In general, if the power per cross-

sectional area is high enough, SRS will occur. A larger cross-sectional area will require a longer length of fiber, if all other variables are held equal. The cladding of multimode fibers may have a diameter of 125 micrometers. The average optical power input into a multimode fiber to generate SRS may be in the range of 1 to 200 watts. The average optical power input into a single mode fiber to generate SRS is generally smaller than the average optical power required to generate SRS in a multimode fiber. The length of the multimode fiber may be in the range of 10 to 300 meters. For average optical power inputs in the range of 3 to 100 watts, the fiber may have a core size of 40 to 62.5 micrometers and a length of 50 to 100 meters. The core material of the optical fiber may be conventional fused silica or the core may be doped with materials such as germanium to increase the SRS effect or change the wavelengths of the SRS peaks.

In order to generate SRS, a large amount of optical power must be coupled into an optical fiber with a limited core diameter. For efficient and reliable coupling, specially built lenses, fibers, and alignment techniques may be necessary. 80 to 90% of the optical power in a free-space laser beam can usually be coupled into a multimode optical fiber. Large-diameter end caps, metalized fibers, double clad fibers, antireflection coatings on fiber faces, gradient index lenses, high temperature adhesives, and other methods are commercially available to couple many tens of watts of average optical power into fibers with core diameters in the range of 30 to 50 micrometers. Photonic or "holey" fibers may be used to make larger diameters with maintaining approximately the same Raman shifting effect. Average optical power in the hundreds of watts can be coupled into fibers with core sizes in the range of 50 to 100 micrometers. The maximum amount of SRS, and therefore the minimum amount of speckle, may be determined by the maximum power that can be reliably coupled into fibers.

Optical fibers experience scattering and absorption which cause loss of optical power. In the visible light region, the main loss is scattering. Conventional fused silica optical fiber has a loss of approximately 15 dB per kilometer in the green. Specially manufactured fiber may be green-optimized so that the loss is 10 dB per kilometer or less in the green. Loss in the blue tends to be higher than loss in the green. Loss in the red tends to be lower than loss in the green. Even with low-loss fiber, the length of fiber used for despeckling may be kept as short as possible to reduce loss. Shorter fiber means smaller core diameter to reach the same amount of SRS and therefore the same amount of despeckling. Since the difficulty of coupling high power may place a limit on the amount of power that can be coupled into a small core, coupling may also limit the minimum length of the fiber.

Lasers used with a fiber-based despeckling apparatus may be pulsed in order to reach the high peak powers required for SRS. The pulse width of the optical pulses may be in the range of 5 to 100 ns. Pulse frequencies may be in the range of 5 to 300 kHz. Peak powers may be in the range of 1 to 1000 W. The peak power per area of core (PPPA) is a metric that can help predict the amount of SRS obtained. The PPPA may be in the range of 1 to 5 kW per micrometer in order to produce adequate SRS for despeckling. Pulsed lasers may be formed by active or passive Q-switching or other methods that can reach high peak power. The mode structure of the pulsed laser may include many peaks closely spaced in wavelength. Other nonlinear effects in addition to SRS may be used to add further despeckling. For example, self-phase modulation or four wave mixing may further broaden the

spectrum to provide additional despeckling. Infrared light may be introduced to the fiber to increase the nonlinear broadening effects.

The despeckling apparatus of FIG. 3 or adjustable despeckling apparatus of FIG. 7 may be used to generate more than one primary color. For example, red primary light may be generated from green light by SRS in an optical fiber to supply some or all of the red light required for a full-color projection display. Since the SRS light has low speckle, adding SRS light to other laser light may reduce the amount of speckle in the combined light. Alternatively, if the starting laser is blue, some or all of the green primary light and red primary light may be generated from blue light by SRS in an optical fiber. Filters may be employed to remove unwanted SRS peaks. In the case of SRS from green light, the red light may be filtered out, or all peaks except the first SRS peak may be filtered out. This filtering will reduce the color change for a given amount of despeckling, but comes at the expense of efficiency if the filtered peaks are not used to help form the viewed image. Filtering out all or part of the un-shifted peak may decrease the speckle because the un-shifted peak typically has a narrower bandwidth than the shifted peaks.

The un-shifted peak after fiber despeckling is a narrow peak that contributes to the speckle of the light exciting the fiber. This unshifted peak may be filtered out from the spectrum (for example using a dichroic filter) and sent into a second despeckling fiber to make further Raman-shifted peaks and thus reduce the intensity of the un-shifted peak while retaining high efficiency. Additional despeckling fibers may cascaded if desired as long as sufficient energy is available in the un-shifted peak.

There are usually three primary colors in conventional full-color display devices, but additional primary colors may also be generated to make, for example, a four-color system or a five-color system. By dividing the SRS light with beamsplitters, the peaks which fall into each color range can be combined together to form each desired primary color. A four-color system may consist of red, green, and blue primaries with an additional yellow primary generated from green light by SRS in an optical fiber. Another four-color system may be formed by a red primary, a blue primary, a green primary in the range of 490 to 520 nm, and another green primary in the range of 520 to 550 nm, where the green primary in the range of 520 to 550 nm is generated by SRS from the green primary in the range of 490 to 520 nm. A five-color system may have a red primary, a blue primary, a green primary in the range of 490 to 520 nm, another green primary in the range of 520 to 550 nm, and a yellow primary, where the green primary in the range of 520 to 550 nm and the yellow primary are generated by SRS from the green primary in the range of 490 to 520 nm.

3D projected images may be formed by using SRS light to generate some or all of the peaks in a six-primary 3D system. Wavelengths utilized for a laser-based six-primary 3D system may be approximately 440 and 450 nm, 525 and 540 nm, and 620 and 640 nm in order to fit the colors into the blue, green, and red bands respectively and have sufficient spacing between the two sets to allow separation by filter glasses. Since the spacing of SRS peaks from a pure fused-silica core is 13.2 THz, this sets a spacing of approximately 9 nm in the blue, 13 nm in the green, and 17 nm in the red. Therefore, a second set of primary wavelengths at 449 nm, 538 nm, and 637 nm can be formed from the first set of primary wavelengths at 440 nm, 525 nm, and 620 nm by utilizing the first SRS-shifted peaks. The second set of primaries may be generated in three separate fibers, or all

three may be generated in one fiber. Doping of the fiber core may be used to change the spacing or generate additional peaks.

Another method for creating a six-primary 3D system is to use the un-shifted (original) green peak plus the third SRS-shifted peak for one green channel and use the first SRS-shifted peak plus the second SRS-shifted peak for the other green channel. Fourth, fifth, and additional SRS-shifted peaks may also be combined with the un-shifted and third SRS-shifted peaks. This method has the advantage of roughly balancing the powers in the two channels. One eye will receive an image with more speckle than the other eye, but the brain can fuse a more speckled image in one eye with a less speckled image in the other eye to form one image with a speckle level that averages the two images. Another advantage is that although the wavelengths of the two green channels are different, the color of the two channels will be more closely matched than when using two single peaks from adjacent green channels. Two red channels and two blue channels may be produced with different temperatures in two OPOs which naturally despeckle the light.

Almost degenerate OPO operation can produce two wavelengths that are only slightly separated. In the case of green light generation, two different bands of green light are produced rather than red and blue bands. The two green wavelengths may be used for the two green primaries of a six-primary 3D system. If the OPO is tuned so that its two green wavelengths are separated by the SRS shift spacing, SRS-shifted peaks from both original green wavelengths will line up at the same wavelengths. This method can be used to despeckle a system utilizing one or more degenerate OPOs.

A different starting wavelength may be used to increase the amount of Raman-shifted light while still maintaining a fixed green point such as DCI green. For example, a laser that generates light at 515 nm may be used as the starting wavelength and more Raman-shifted light generated to reach the DCI green point when compared to a starting wavelength of 523.5 nm. The effect of starting at 515 nm is that the resultant light at the same green point will have less speckle than light starting at 523.5 nm.

When two separate green lasers, one starting at 523.5 nm and one starting at 515 nm, are both fiber despeckled and then combined into one system, the resultant speckle will be even less than each system separately because of the increased spectral diversity. The Raman-shifted peaks from these two lasers will interleave to make a resultant waveform with approximately twice as many peaks as each green laser would have with separate operation.

A separate blue boost may also be added from a narrow band laser at any desired wavelength because speckle is very hard to see in blue even with narrow band light. The blue boost may be a diode-pumped solid-state (DPSS) or direct diode laser. The blue boost may form one of the blue peaks in a six-primary 3D display. If blue boost is used, any OPOs in the system may be tuned to produce primarily red or red only so as to increase the red efficiency.

Peaks that are SRS-shifted from green to red may be added to the red light from an OPO or may be used to supply all the red light if there is no OPO. In the case of six-primary 3D, one or more peaks shifted to red may form or help form one or more of the red channels.

Instead of or in addition to fused silica, materials may be used that add, remove, or alter SRS peaks as desired. These additional materials may be dopants or may be bulk materials added at the beginning or the end of the optical fiber.

The cladding of the optical fiber keeps the peak power density high in the fiber core by containing the light in a small volume. Instead of or in addition to cladding, various methods may be used to contain the light such as mirrors, focusing optics, or multi-pass optics. Instead of an optical fiber, larger diameter optics may be used such as a bulk glass or crystal rod or rectangular parallelepiped. Multiple passes through a crystal or rod may be required to build sufficient intensity to generate SRS. Liquid waveguides may be used and may add flexibility when the diameter is increased.

Polarization-preserving fiber or other polarization-preserving optical elements may be used to contain the light that generates SRS. A rectangular-cross-section integrating rod or rectangular-cross-section fiber are examples of polarization-preserving elements. Polarization-preserving fibers may include core asymmetry or multiple stress-raising rods that guide polarized light in such a way as to maintain polarization.

In a typical projection system, there is a trade-off between brightness, contrast ratio, uniformity, and speckle. High illumination $f\#$ tends to produce high brightness and high contrast ratio, but also tends to give low uniformity and more speckle. Low illumination $f\#$ tends to produce high uniformity and low speckle, but also tends to give low brightness and low contrast ratio. By using spectral broadening to reduce speckle, the $f\#$ of the illumination system can be raised to help increase brightness and contrast ratio while keeping low speckle. Additional changes may be required to make high uniformity at high $f\#$, such as a longer integrating rod, or other homogenization techniques which are known and used in projection illumination assemblies.

If two OPOs are used together, the OPOs may be adjusted to slightly different temperatures so that the resultant wavelengths are different. Although the net wavelength can still achieve the target color, the bandwidth is increased to be the sum of the bandwidths of the individual OPOs. Increased despeckling will result from the increased bandwidth. The bands produced by each OPO may be adjacent, or may be separated by a gap. In the case of red and blue generation, both red and blue will be widened when using this technique. For systems with three primary colors, there may be two closely-spaced red peaks, four or more green peaks, and two closely-spaced blue peaks. For systems with six primary colors, there may be three or more red peaks with two or more of the red peaks being closely spaced, four or more green peaks, and three or more blue peaks with two or more of the blue peaks being closely spaced. Instead of OPOs, other laser technologies may be used that can generate the required multiple wavelengths.

Screen vibration or shaking is a well-known method of reducing speckle. The amount of screen vibration necessary to reduce speckle to a tolerable level depends on a variety of factors including the spectral diversity of the laser light impinging on the screen. By using Raman to broaden the spectrum of light, the required screen vibration can be dramatically reduced even for silver screens or high-gain white screens that are commonly used for polarized 3D or very large theaters. These specialized screens typically show more speckle than low-gain screens. When using Raman despeckling, screen vibration may be reduced to a level on the order of a millimeter or even a fraction of a millimeter, so that screen vibration becomes practical and easily applied even in the case of large cinema screens.

When the Raman despeckling process is driven with high enough peak power, the green starting wavelength may be Raman shifted through the yellow wavelengths and out to red wavelengths. If sufficient red is produced, both broad-

band green light and broadband red light can be made simultaneously from the same starting laser. Such a system can provide both green and red primary colors for digital projection. When blue light is added separately, all three of the conventional primary colors are available to form full color digital images.

The starting green wavelength may be selected to generate a sufficient amount of Raman-shifted red light. If the starting wavelength is 532 nm, more red may be generated than if starting at 523.5 nm, for example, because 532 nm requires less Raman shift to reach the red range of wavelengths. If the x-value of the green primary color generated by the Raman shift process is not low enough to maintain the correct green point (to meet the DCI standard, the x-value should be 0.265), green laser diodes may be added in the approximate range of 515 nm to 525 nm to pull the x-value down. Similarly, if the x-value of the red primary color generated by the Raman shift process is not high enough to maintain the desired red point (to meet the DCI standard, the x-value should be 0.68), red laser diodes may be added to pull the x-value up.

Control of the despeckling process may be achieved by varying the repetition rate of the pulsed laser. For master-oscillator power-amplifier (MOPA) laser systems such as some of the conventionally available fiber lasers, the average laser output power may generally be adjusted without affecting peak power or pulse width by changing the pulse repetition rate. In this case, the brightnesses of Raman-shifted green and red primaries can be kept constant over time or changed to achieve various effects such as equal brightness of 2D mode and 3D mode. The despeckled color of green and red may stay substantially constant over a wide range of repetition rate, which may be useful for adjusting brightness while maintaining the desired color points of the green and red primaries in digital projection applications.

FIG. 15 shows a laser projection system with a pulsed green laser, a green laser diode assembly, and a red diode assembly. FIG. 15 shows a top view of a laser projector system that includes a green laser diode assembly and a green pulsed laser. Green laser diode assembly 1502 generates first light beam 1504. First light beam 1504 illuminates first light coupling system 1506. First light coupling system 1506 generates second light beam 1508. Second light beam 1508 illuminates first optical fiber 1510 which has first core 1512. First optical fiber 1510 generates third light beam 1514. Third light beam 1514 illuminates homogenizing device 1544. Green pulsed laser 1516 generates fourth light beam 1518. Fourth light beam 1518 illuminates second light coupling system 1520. Second light coupling system 1520 generates fifth light beam 1522. Fifth light beam 1522 illuminates second optical fiber 1524 which has second core 1526. Second optical fiber 1524 generates SRS that is included in sixth light beam 1528. Sixth light beam 1528 includes both green light and red light. Sixth light beam 1528 illuminates homogenizing device 1544. Red laser diode assembly 1530 generates seventh light beam 1532. Seventh light beam 1532 illuminates third light coupling system 1534. Third light coupling system 1534 generates eighth light beam 1536. Eighth light beam 1536 illuminates third optical fiber 1538 which has third core 1540. First optical fiber 1538 generates ninth light beam 1542. Ninth light beam 1542 illuminates homogenizing device 1544.

Homogenizing device 1544 combines third light beam 1514, sixth light beam 1528, and ninth light beam 1542 to generate tenth light beam 1546. Tenth light beam 1546 illuminates digital projector 1548. Within digital projector 1548, the green light from third light beam 1514 and the

green light from sixth light beam 1528 are combined to form green primary light which is included in eleventh light beam 1550 which is projected from digital projector 1548. Within digital projector 1548, the red light from ninth light beam 1542 and the red light from sixth light beam 1528 are combined to form red primary light which is included in eleventh light beam 1550 which is projected from digital projector 1548.

There may be additional elements not shown in FIG. 15 which are between the parts illuminating and the parts being illuminated. For example, there may be additional lenses before homogenizing device 1544 to adjust the divergence of the light beams so that the homogenizing device operates with the proper amount of homogenization. Green laser diode assembly 1502 does not generate SRS in first optical fiber 1510. Red laser diode assembly 1530 does not generate SRS in third optical fiber 1538. Green pulsed laser 1516 is a pulsed laser that has high enough peak power to produce SRS in second optical fiber 1524. Green pulsed laser 1516 may be a DPSS laser and may further be a MOPA fiber laser system. First light coupling system 1506, second light coupling system 1520, and third light coupling system 1534 may each be one lens, a sequence of lenses, or other optical components designed to focus light into first core 1512, second core 1526, and third core 1540. Second optical fiber 1524 may be an optical fiber with a core size and length selected to produce the desired amount of SRS. Homogenizing device 1544 may be a mixing rod, fly's eye lens, diffuser, or other optical component that improves the spatial uniformity of the light beam. Digital projector 1548 may be a projector based on digital micromirror (DMD) light valves. Green pulsed laser 1516 may have a repetition rate greater than 280 kHz. For example, the repetition rate may be in the range of 300 to 600 kHz. Additional elements may be included to further guide or despeckle the light such as additional lenses, diffusers, vibrators, or optical fibers. Instead of homogenizing element 1544, other ways may be employed to combine the light from third light beam 1514, sixth light beam 1528, and ninth light beam 1542. Green laser diode assembly 1502 may include multiple, individual green laser diodes aggregated to increase the power and bandwidth. Red laser diode assembly 1530 may include multiple, individual green laser diodes aggregated to increase the power and bandwidth.

FIG. 16 shows a graph of power vs. repetition rate for a pulsed green laser. The x-axis represents laser pulse repetition rate in kHz. The y-axis represents laser output power in Watts. Curve 1600 shows a linear relationship between the repetition rate and the laser output power over a wide range of 100 to 600 kHz for an example of a MOPA fiber laser system operating at 532 nm. Curve 1600 illustrates the concept of adjusting the laser output power by varying the laser repetition rate. If the repetition rate is kept above a certain critical frequency, typical DLP-based projection systems will generally operate in a quasi-CW mode where there is no need to synchronize the projector and the pulsed laser. Depending on the specific projector configuration, the critical frequency may be approximately 280 kHz, 300 kHz, or higher.

FIG. 17 shows a graph of color vs. repetition rate for a pulsed green laser. The x-axis represents laser pulse repetition rate in kHz. The y-axis represents the color of despeckled green output from an optical fiber with Raman despeckling. In this case, the same MOPA fiber laser system was used as in FIG. 16, but an additional step of fiber despeckling with SRS was added so that the Raman-shifted peaks are generated from the 532 nm starting wavelength. In this

example, the Raman peaks are mainly generated in the yellow and only a small amount of red, so the resultant overall color is equivalent to a wavelength of about 553 nm which is yellowish green. Curve **1700** illustrates the concept of keeping the x-value nearly constant at approximately 0.320 over the wide range of operating powers that are obtained with repetition rates varying from 300 kHz to 600 kHz.

FIG. **18** shows a graph of intensity vs. wavelength for a despeckled pulsed green laser. The x-axis represents wavelength in nanometers and the y-axis represents intensity on a linear scale normalized to the highest peak. Curve **1800** shows the output of a MOPA fiber laser system and Raman despeckling fiber with parameters selected to make substantial output in the range of red light wavelengths 600 to 630 nm. This range covers the most effective wavelength region to generate red light that meets the requirements of the DCI standard red point which has x and y values that are equivalent to a single wavelength of 615 nm. First peak **1802** at 532 nm is residual light at the laser starting wavelength of 532 nm which is not Raman scattered. The spectral bandwidth of first peak **1802** is much narrower than the displayed value in FIG. **18** because the resolution of the spectral measurement is approximately 5 nm, so the actual width of first peak **1802** cannot be resolved in FIG. **18**. Second peak **1804** at 536.5 nm, third peak **1806**, fourth peak **1808**, fifth peak **1810**, sixth peak **1812**, seventh peak **1814**, and eighth peak **1816** are successive SRS peaks shifted from first peak **1802**.

FIG. **19** shows a graph of intensity vs. wavelength for a despeckled pulsed green laser formed into green and red primaries. The x-axis represents wavelength in nanometers and the y-axis represents intensity on a linear scale normalized to the highest peak. First curve **1900** shows the output of a MOPA fiber laser system and Raman despeckling fiber with parameters selected to make substantial output in the red, and then filtered through a DCI-compliant digital cinema projector to form a green primary. Second curve **1902** utilizes the same Raman despeckling fiber output as first curve **1900**, but is simultaneously filtered by the same DCI-compliant digital cinema projector to form a red primary. Third curve **1904** is a replot of second curve **1902** with the human eye photopic weighting curve incorporated. The photopically-weighted full-width-half-maximum bandwidth of third curve **1904** is approximately 30 nm. The photopically-weighted full-width-half-maximum bandwidth of the red primary may be greater than 15 nm to achieve a sufficiently low level of red speckle. The spectrum of the Raman despeckling fiber output in FIG. **19** is not the same as the spectrum of the fiber output in FIG. **18** because different MOPA fiber laser system parameters were used for these two examples.

FIG. **20** shows a graph of intensity vs. wavelength for a despeckled pulsed green laser with green laser diodes and red laser diodes. The x-axis represents wavelength in nanometers and the y-axis represents intensity on a linear scale normalized to the highest peak. Curve **2000** shows the output of a MOPA fiber laser system and Raman despeckling fiber with parameters selected to make substantial output in the range of 600 to 630 nm. The despeckled green and red peaks from the despeckling fiber are second peak **2004**, third peak **2006**, fourth peak **2008**, fifth peak **2010**, sixth peak **2012**, seventh peak **2014**, and eighth peak **2016**. The despeckled green and red peaks from the despeckling fiber are combined with first peak **2002** which represents the light from a green laser diode assembly, and ninth peak **2018** which represents the light from a red laser diode assembly.

Green laser diode peak **2002** is shown in this example at 520 nm, but may be most effectively in the range of 515 nm to 525 nm. Red laser diode peak **2018** is shown in this example at 638 nm, but may be most effectively in the range of 630 nm to 660 nm. The brightness of the red light from the Raman despeckling fiber may be greater than 20% of the total red light from the Raman despeckling fiber combined with the red laser diode assembly in order to achieve sufficient bandwidth to reduce red speckle to a tolerable level. The spectrum of the Raman despeckling fiber output in FIG. **20** is the same as the spectrum of the fiber output in FIG. **18**.

FIG. **21** shows a flowchart of a despeckling method that uses pulsed green laser light, green diode laser light, and red diode laser light. In step **2102**, green light is generated from a green laser diode assembly. In step **2104** green light is generated by a pulsed green laser. In step **2106**, the pulsed green light is focused into an optical fiber. In step **2107**, SRS light is generated in the optical fiber. In step **2110**, the SRS light is used to enhance the light output of the optical fiber. In step **2112**, the light output from the optical fiber is separated into green light and red light. In step **2116**, the green light from the green laser diode assembly is combined with the green light from the Raman despeckling to form green primary light. In step **2118**, the red light from the red laser diode assembly is combined with the red light from the Raman despeckling to form red primary light. In step **2120**, the green primary light formed in step **2116** and the red primary light formed in step **2118** are combined together to project a digital image. Steps **2112**, **2116**, and **2118** are typically performed in a digital projector, but may be performed before the light enters a digital projector.

Laser diode assemblies may consist of one or more individual semiconductor laser diode single emitters or bars with multiple emitters per bar. The assemblies may include aggregation optics such as lenses, mirrors, filters, beamsplitters, and optical fibers.

In order to drive the Raman effect to the point where significant red light is generated and the risk of fiber damage is minimized, it may be advantageous to use short laser pulses in the range of 0.1 to 10 ns. These short pulses may be generated by a MOPA fiber laser system or mode-locked laser which may be constructed from various combinations of optical oscillators and one or more stages of optical amplification. If the optical oscillator has a short cavity on the order of millimeters or less, the oscillator is capable of generating short pulses. MOPA fiber laser systems may be constructed with a short-pulse master oscillator formed from a microchip laser or a pulsed laser diode. One, two, or more stages of amplification may be added with doped-fiber lengths that are pumped by additional laser diodes coupled with additional optical fibers.

Other implementations are also within the scope of the following claims.

What is claimed is:

1. An optical apparatus comprising:

a pulsed laser with a pulse repetition rate that generates a first green light;
a green laser diode assembly that generates a second green light;
and an optical fiber;

wherein the first green light is focused into the optical fiber;

the optical fiber generates a stimulated Raman scattering light that enhances an aspect of a light output of the optical fiber and broadens a spectrum of the green light to produce a first red light;

19

the light output from the optical fiber is separated into a third green light and the first red light, the second green light and the third green light are combined to comprise a green primary light of a projected digital image, and the first red light comprises a red primary light of the projected digital image.

2. The apparatus of claim 1 wherein the aspect of the light output of the optical fiber is a color of the output of the optical fiber.

3. The apparatus of claim 1 wherein the aspect of the light output of the optical fiber is a speckle characteristic of the output of the optical fiber.

4. The apparatus of claim 1 further comprising: a red laser diode assembly that generates a second red light; wherein the first red light is combined with the second red light to comprise the red primary light.

5. The apparatus of claim 4 wherein a brightness of the first red light forms greater than 20% of a brightness of the red primary light.

6. The apparatus of claim 1 wherein the photopically-weighted full-width-half-maximum bandwidth of the red primary light is greater than 15 nm.

7. The apparatus of claim 1 wherein the pulse repetition rate is used to control a brightness of the green primary light.

8. The apparatus of claim 7 wherein the green primary light is held at a constant color.

9. The apparatus of claim 1 wherein the first green laser has a wavelength of 532 nm.

10. The apparatus of claim 1 wherein the pulsed laser comprises a master-oscillator power-amplifier fiber-laser system.

11. The apparatus of claim 1 wherein the pulse repetition rate is greater than 280 kHz.

12. An image projection method comprising:
generating a first green laser light from a pulsed laser; the pulsed laser having a pulse repetition rate;
generating a second green laser light from a green laser diode assembly;

20

focusing the first green laser light into an optical fiber; generating a stimulated Raman scattering light in the optical fiber;

using the stimulated Raman scattering light to enhance an aspect of a light output of the optical fiber by broadening a spectrum of the green light to produce a first red light;

separating the light output from the optical fiber into a third green light and the first red light;

combining the second green light and the third green light to comprise a green primary light; using the first red light to comprise a red primary light; and

using the green primary light and the red primary light to project a digital image.

13. The method of claim 12 wherein the aspect of the light output of the optical fiber is a color of the output of the optical fiber.

14. The method of claim 12 wherein the aspect of the light output of the optical fiber is a speckle characteristic of the output of the optical fiber.

15. The method of claim 12 further comprising: generating a second red light from a red laser diode assembly; and combining the first red light with the second red light to comprise the red primary light.

16. The method of claim 12 wherein the photopically-weighted full-width-half-maximum bandwidth of the red primary light is greater than 15 nm.

17. The method of claim 12 wherein the pulse repetition rate is used to control a brightness of the green primary light.

18. The method of claim 17 wherein the green primary light is held at a constant color.

19. The method of claim 12 wherein the pulsed laser comprises a master-oscillator power-amplifier fiber-laser system.

20. The method of claim 12 wherein the pulse repetition rate is greater than 280 kHz.

* * * * *

UNITED STATES PATENT AND TRADEMARK OFFICE
CERTIFICATE OF CORRECTION

PATENT NO. : 9,715,123 B2
APPLICATION NO. : 13/964332
DATED : July 25, 2017
INVENTOR(S) : John Arntsen et al.

Page 1 of 1

It is certified that error appears in the above-identified patent and that said Letters Patent is hereby corrected as shown below:

In Column 13, Line 34, delete “may used” and insert -- may be used --, therefor.

In Column 14, Line 6, delete “may used” and insert -- may be used --, therefor.

Signed and Sealed this
Twenty-eighth Day of November, 2017



Joseph Matal

*Performing the Functions and Duties of the
Under Secretary of Commerce for Intellectual Property and
Director of the United States Patent and Trademark Office*