

US009707088B2

(12) **United States Patent**
Samuelson et al.

(10) **Patent No.:** **US 9,707,088 B2**
(45) **Date of Patent:** ***Jul. 18, 2017**

(54) **SYSTEMS AND METHODS FOR PROVIDING A STEM ON A TIBIAL COMPONENT**

(71) Applicants: **Connor E Samuelson**, Salt Lake City, UT (US); **Kent M Samuelson**, Salt Lake City, UT (US)

(72) Inventors: **Connor E Samuelson**, Salt Lake City, UT (US); **Kent M Samuelson**, Salt Lake City, UT (US)

(*) Notice: Subject to any disclaimer, the term of this patent is extended or adjusted under 35 U.S.C. 154(b) by 0 days.

This patent is subject to a terminal disclaimer.

(21) Appl. No.: **14/822,764**

(22) Filed: **Aug. 10, 2015**

(65) **Prior Publication Data**

US 2016/0038292 A1 Feb. 11, 2016

Related U.S. Application Data

(63) Continuation of application No. 13/758,855, filed on Feb. 4, 2013, now Pat. No. 9,101,476, which is a continuation of application No. 12/797,372, filed on Jun. 9, 2010, now Pat. No. 8,366,783, which is a continuation-in-part of application No. 12/482,280, (Continued)

(51) **Int. Cl.**
A61F 2/38 (2006.01)
A61B 17/15 (2006.01)
A61F 2/30 (2006.01)

(52) **U.S. Cl.**
CPC *A61F 2/389* (2013.01); *A61B 17/155* (2013.01); *A61B 17/157* (2013.01); *A61F 2/30734* (2013.01); *A61F 2/38* (2013.01); *A61F 2/3859* (2013.01); *A61F 2/30965*

(2013.01); *A61F 2/3877* (2013.01); *A61F 2002/30116* (2013.01); *A61F 2002/30245* (2013.01); *A61F 2002/30604* (2013.01); *A61F 2002/30624* (2013.01); *A61F 2002/30934* (2013.01); *A61F 2002/3895* (2013.01); *A61F 2230/0006* (2013.01); *A61F 2230/0071* (2013.01); *A61F 2310/00011* (2013.01); *A61F 2310/00179* (2013.01);

(Continued)

(58) **Field of Classification Search**
CPC *A61F 2/3868*; *A61F 2/3859*
See application file for complete search history.

(56) **References Cited**

U.S. PATENT DOCUMENTS

4,209,861 A 7/1980 Walker et al.
4,487,203 A 12/1984 Androphy
(Continued)

FOREIGN PATENT DOCUMENTS

CN 1874738 A 12/2006
CN 101123928 A 2/2008
(Continued)

Primary Examiner — Jason-Dennis Stewart
(74) *Attorney, Agent, or Firm* — David B. Tingey; Bryant J. Keller; Kirton McConkie

(57) **ABSTRACT**

Systems and methods for providing a tibial prosthesis are disclosed. In some cases, the prosthesis includes a tibial component for replacing at least a portion of a proximal end of a tibia, the tibial component having an undersurface and a stem that extends from the undersurface, wherein the stem is configured to contact an inner, anterior surface of the tibia when the stem is inserted into the tibia and the undersurface of the tibial component is in contact with a cut surface of the tibia. Other implementations are described.

20 Claims, 62 Drawing Sheets

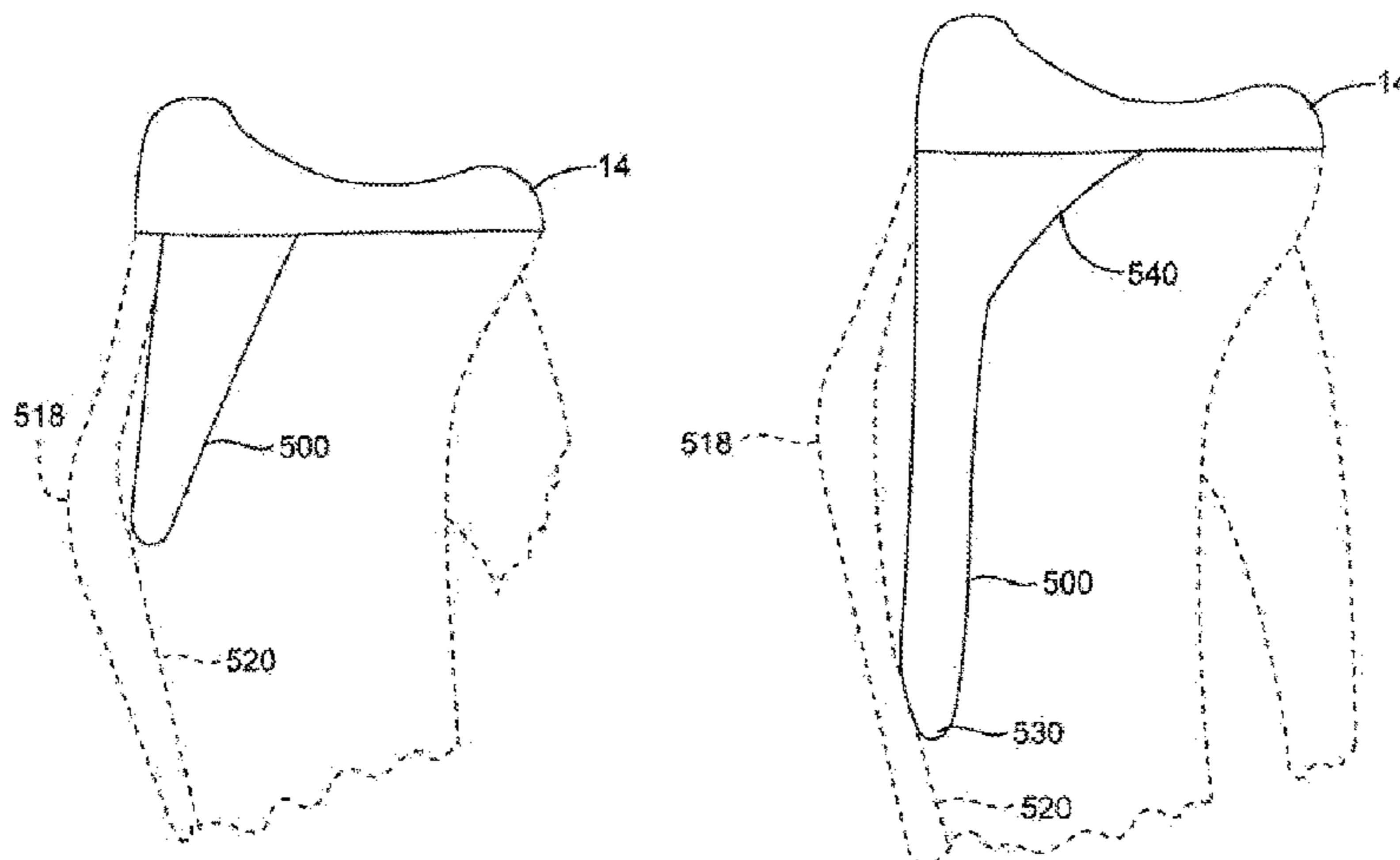

Related U.S. Application Data

filed on Jun. 10, 2009, now Pat. No. 8,382,846, which is a continuation-in-part of application No. 12/198,001, filed on Aug. 25, 2008, now Pat. No. 8,273,133.

- (60) Provisional application No. 60/972,191, filed on Sep. 13, 2007, provisional application No. 60/968,246, filed on Aug. 27, 2007.
- (52) **U.S. Cl.**
CPC *A61F 2310/00329* (2013.01); *A61F 2310/00353* (2013.01)

(56) **References Cited**

U.S. PATENT DOCUMENTS

| | | | |
|-----------|----|---------|------------------|
| 4,721,104 | A | 1/1988 | Kaufman et al. |
| 4,743,261 | A | 5/1988 | Epinette |
| 4,865,606 | A | 9/1989 | Rehder |
| 5,133,760 | A | 7/1992 | Petersen et al. |
| 5,219,362 | A | 6/1993 | Tuke et al. |
| 5,236,461 | A | 8/1993 | Forte |
| 5,250,050 | A | 10/1993 | Poggie et al. |
| 5,358,527 | A | 10/1994 | Forte |
| 5,387,240 | A | 2/1995 | Pottenger et al. |
| 5,549,688 | A | 8/1996 | Ries et al. |
| 5,728,162 | A | 3/1998 | Eckhoff |
| 5,788,916 | A | 8/1998 | Caldarise |
| 5,800,438 | A | 9/1998 | Tuke et al. |
| 5,824,100 | A | 10/1998 | Kester et al. |
| 5,879,389 | A | 3/1999 | Koshino |
| 5,925,049 | A | 7/1999 | Gustilo et al. |
| 5,964,808 | A | 10/1999 | Blaha et al. |
| 6,013,103 | A | 1/2000 | Kaufman et al. |
| 6,039,764 | A | 3/2000 | Pottenger et al. |
| 6,126,691 | A | 10/2000 | Kasra et al. |
| 6,146,424 | A | 11/2000 | Gray, Jr. et al. |
| 6,149,687 | A | 11/2000 | Gray, Jr. et al. |
| 6,159,217 | A | 12/2000 | Robie et al. |
| 6,190,415 | B1 | 2/2001 | Cooke et al. |
| 6,206,927 | B1 | 3/2001 | Fell et al. |
| 6,319,283 | B1 | 11/2001 | Insall et al. |
| 6,402,786 | B1 | 6/2002 | Insall et al. |
| 6,491,726 | B2 | 12/2002 | Pappas |
| 7,264,635 | B2 | 9/2007 | Suguro et al. |
| 7,297,164 | B2 | 11/2007 | Johnson et al. |
| 7,326,252 | B2 | 2/2008 | Otto et al. |
| 7,615,082 | B2 | 11/2009 | Naegerl et al. |
| 7,766,969 | B2 | 8/2010 | Justin et al. |
| 8,273,133 | B2 | 9/2012 | Samuelson |
| 8,366,783 | B2 | 2/2013 | Samuelson et al. |
| 8,382,846 | B2 | 2/2013 | Samuelson et al. |
| 8,715,357 | B2 | 5/2014 | Samuelson et al. |
| 8,715,360 | B2 | 5/2014 | Samuelson et al. |
| 8,715,361 | B2 | 5/2014 | Samuelson et al. |
| 8,721,731 | B2 | 5/2014 | Samuelson et al. |
| 8,721,732 | B2 | 5/2014 | Samuelson et al. |
| 8,784,497 | B2 | 7/2014 | Samuelson et al. |
| 9,101,478 | B2 | 8/2015 | Samuelson et al. |
| 9,107,769 | B2 | 8/2015 | Samuelson et al. |
| 9,265,615 | B2 | 2/2016 | Samuelson et al. |
| 9,265,624 | B2 | 2/2016 | Samuelson et al. |
| 9,320,616 | B2 | 4/2016 | Samuelson et al. |
| 9,326,867 | B2 | 5/2016 | Samuelson et al. |
| 9,326,868 | B2 | 5/2016 | Samuelson et al. |
| 9,339,391 | B2 | 5/2016 | Samuelson et al. |

| | | | |
|--------------|----|---------|--------------------|
| 9,427,332 | B2 | 8/2016 | Samuelson et al. |
| 2002/0115934 | A1 | 8/2002 | Tuke et al. |
| 2003/0100953 | A1 | 5/2003 | Rosa et al. |
| 2003/0139817 | A1 | 7/2003 | Tuke et al. |
| 2004/0006393 | A1 | 1/2004 | Burkinshaw |
| 2004/0078042 | A1 | 4/2004 | Masini |
| 2004/0243244 | A1 | 12/2004 | Otto et al. |
| 2005/0021147 | A1 | 1/2005 | Tarabichi |
| 2005/0096747 | A1 | 5/2005 | Tuttle et al. |
| 2005/0143837 | A1 | 6/2005 | Ferree |
| 2005/0197710 | A1 | 9/2005 | Naegerl |
| 2005/0278034 | A1 | 12/2005 | Johnson et al. |
| 2006/0004465 | A1 | 1/2006 | Bergin et al. |
| 2007/0135926 | A1 | 6/2007 | Walker |
| 2008/0009950 | A1 | 1/2008 | Richardson |
| 2008/0058945 | A1 | 3/2008 | Hajaj et al. |
| 2008/0140212 | A1 | 6/2008 | Metzger et al. |
| 2008/0161918 | A1 | 7/2008 | Fankhauser et al. |
| 2008/0243258 | A1 | 10/2008 | Sancheti |
| 2009/0043395 | A1 | 2/2009 | Hotokebuchi et al. |
| 2009/0082873 | A1 | 3/2009 | Hazebrouck et al. |
| 2009/0088861 | A1 | 4/2009 | Tuke et al. |
| 2009/0149963 | A1 | 6/2009 | Sekel |
| 2009/0326667 | A1 | 12/2009 | Williams et al. |
| 2010/0036499 | A1 | 2/2010 | Pinskerova |
| 2011/0266265 | A1 | 11/2011 | Lang |
| 2012/0209394 | A1 | 8/2012 | Bojarski et al. |
| 2013/0024002 | A1 | 1/2013 | Samuelson |
| 2013/0178945 | A1 | 7/2013 | Samuelson et al. |
| 2013/0197654 | A1 | 8/2013 | Samuelson et al. |
| 2013/0204252 | A1 | 8/2013 | Samuelson et al. |
| 2014/0142713 | A1 | 5/2014 | Wright et al. |
| 2014/0296989 | A1 | 10/2014 | Samuelson et al. |
| 2014/0296992 | A1 | 10/2014 | Samuelson et al. |
| 2014/0296993 | A1 | 10/2014 | Samuelson et al. |
| 2014/0296994 | A1 | 10/2014 | Samuelson et al. |
| 2014/0336773 | A1 | 11/2014 | Samuelson et al. |
| 2014/0350687 | A1 | 11/2014 | Samuelson et al. |
| 2015/0351920 | A1 | 12/2015 | Samuelson et al. |
| 2016/0228255 | A1 | 8/2016 | Samuelson et al. |
| 2016/0235541 | A1 | 8/2016 | Samuelson et al. |
| 2016/0242915 | A1 | 8/2016 | Samuelson et al. |
| 2016/0242916 | A1 | 8/2016 | Samuelson et al. |
| 2016/0242918 | A1 | 8/2016 | Samuelson et al. |
| 2016/0256283 | A1 | 9/2016 | Samuelson et al. |

FOREIGN PATENT DOCUMENTS

| | | | |
|----|----------------|----|---------|
| EP | 0 978 261 | A1 | 2/2000 |
| GB | 1360485 | | 7/1974 |
| JP | H01068257 | | 3/1989 |
| JP | H02203854 | | 8/1990 |
| JP | H10155824 | | 6/1998 |
| JP | 2007509709 | | 4/2007 |
| JP | 2007152116 | | 6/2007 |
| JP | 2009515610 | | 4/2009 |
| WO | WO 94/20047 | A1 | 9/1994 |
| WO | WO 96/24311 | A1 | 8/1996 |
| WO | WO 98/52499 | A1 | 5/1998 |
| WO | WO 2003/099106 | A2 | 12/2003 |
| WO | WO 2004/058108 | A1 | 7/2004 |
| WO | WO 2004/066882 | A1 | 8/2004 |
| WO | WO 2006/092167 | A1 | 9/2006 |
| WO | WO 2007/007841 | A1 | 1/2007 |
| WO | WO 2007/053905 | A1 | 5/2007 |
| WO | WO 2007/119173 | A2 | 10/2007 |
| WO | WO 2008/028481 | A1 | 3/2008 |
| WO | WO 2009/029631 | A1 | 3/2009 |
| WO | WO 2010/144736 | A1 | 12/2010 |

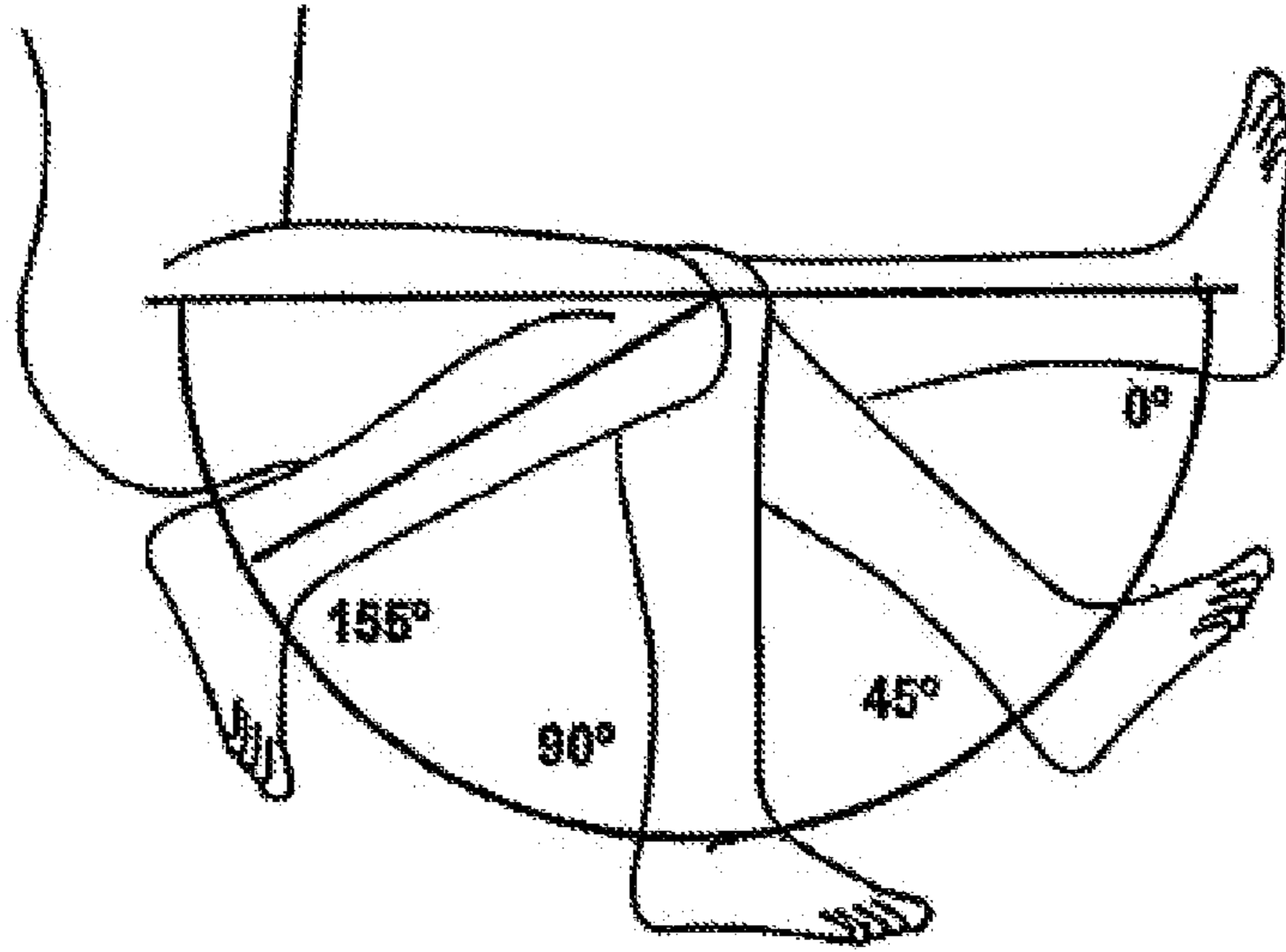

Figure 1A

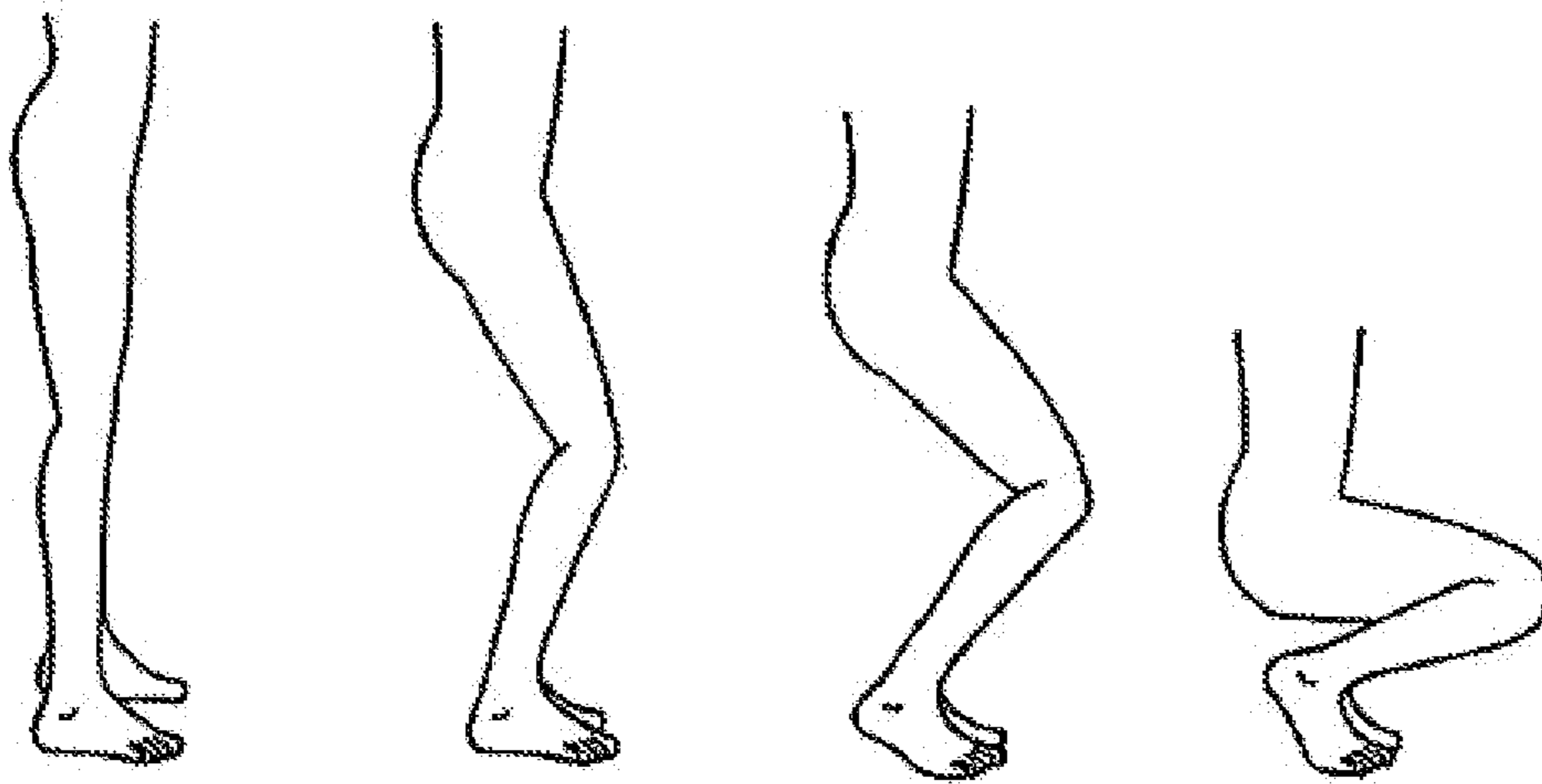

Figure 1B

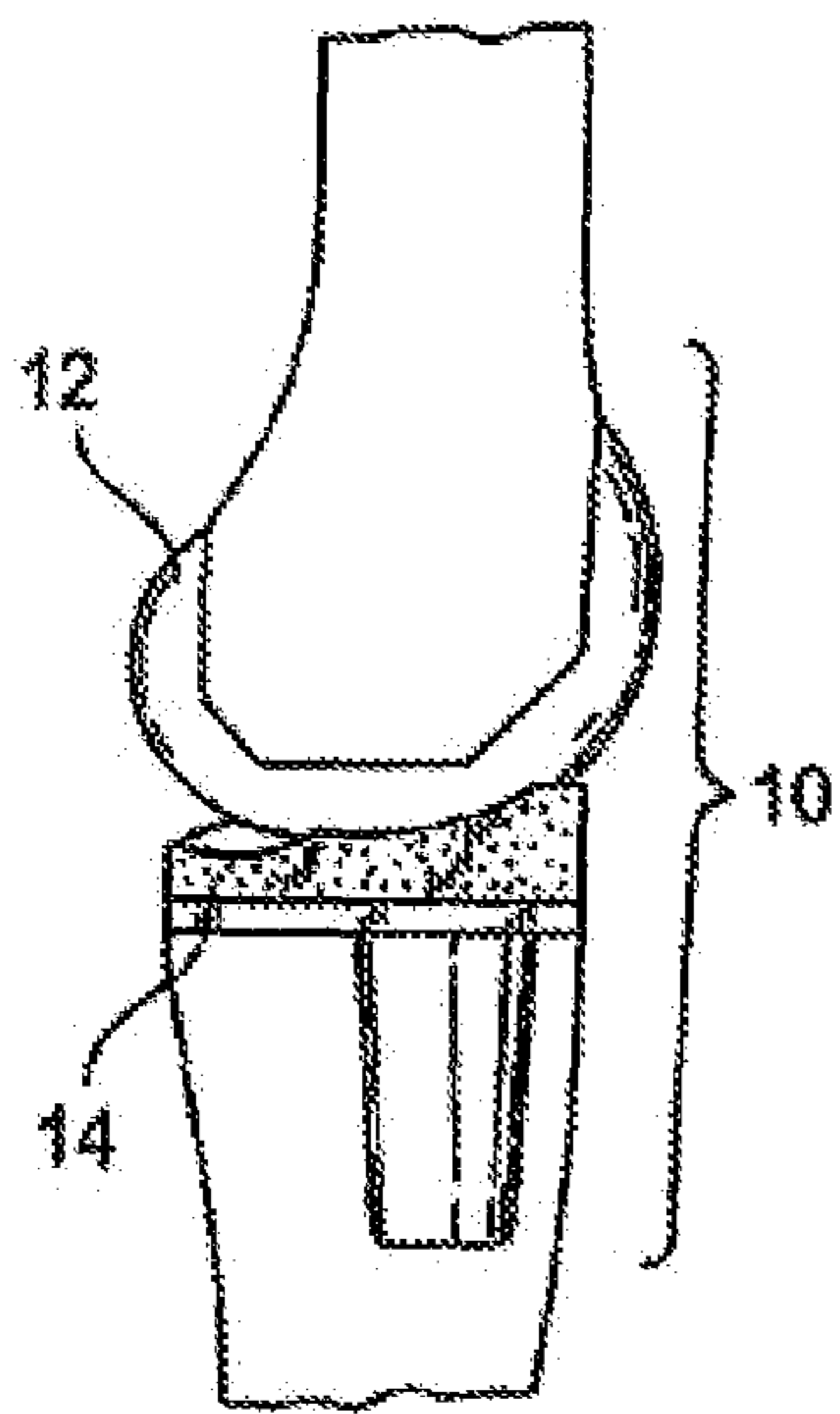

Figure 2A

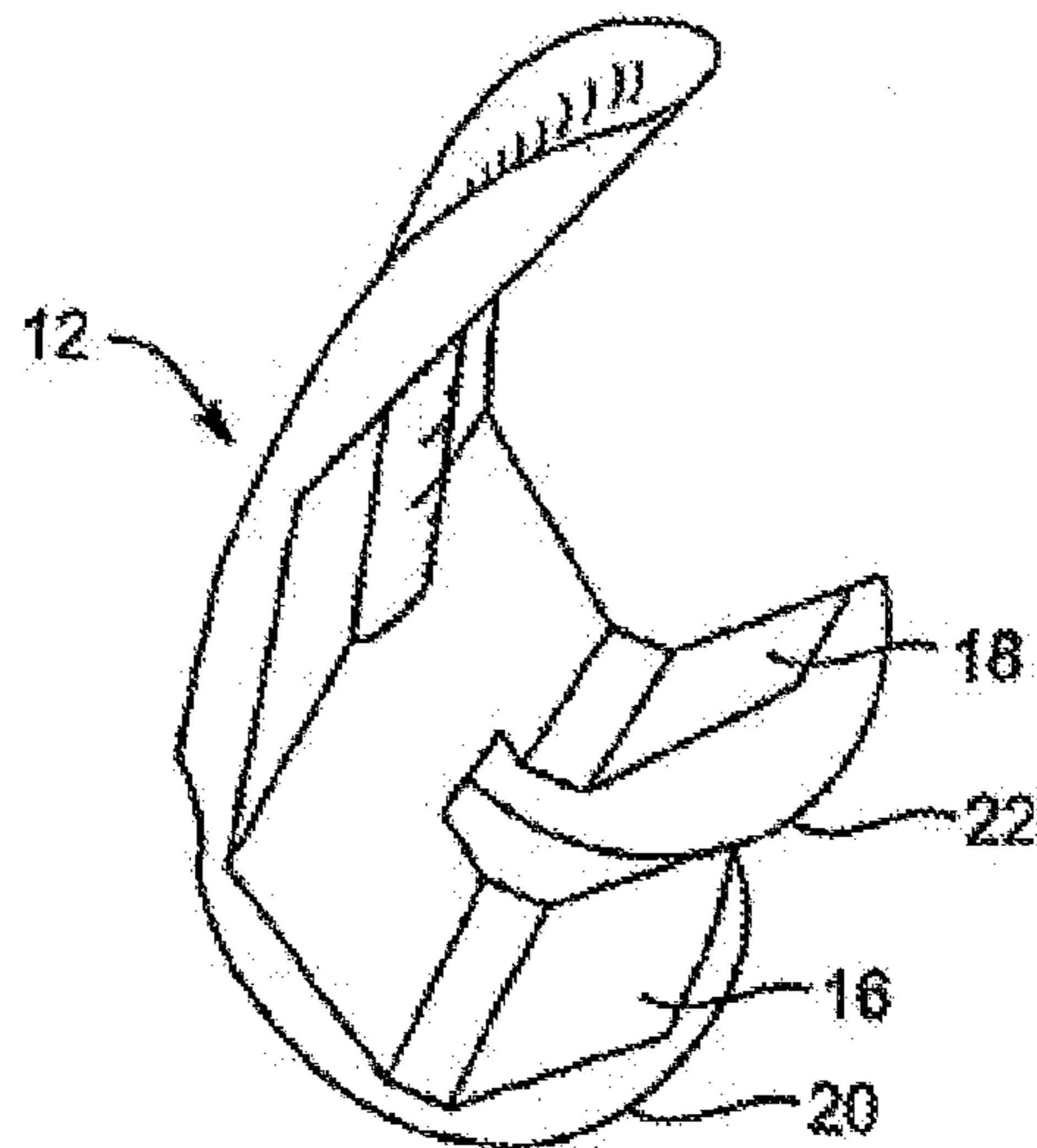

Figure 2B

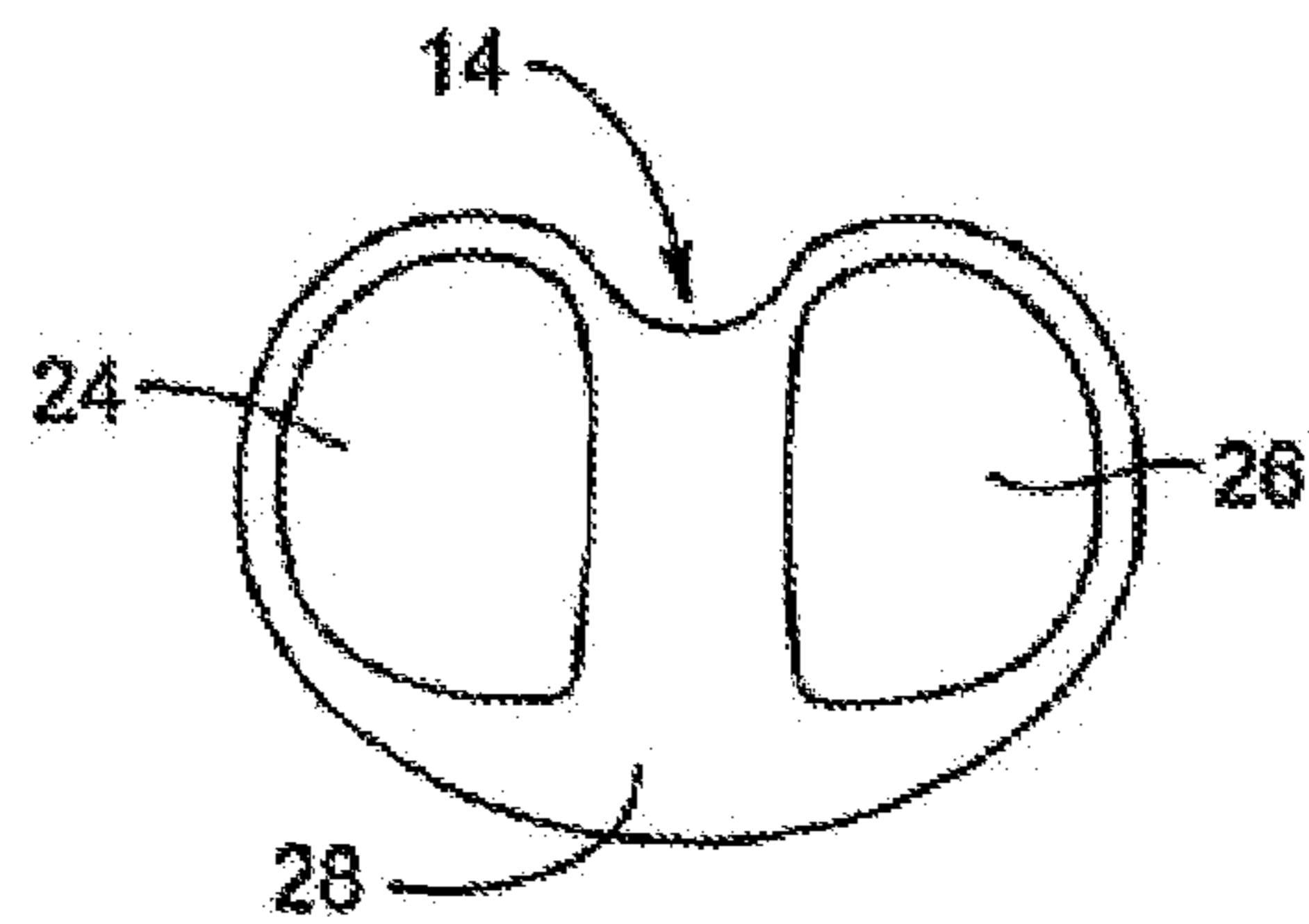

Figure 2C

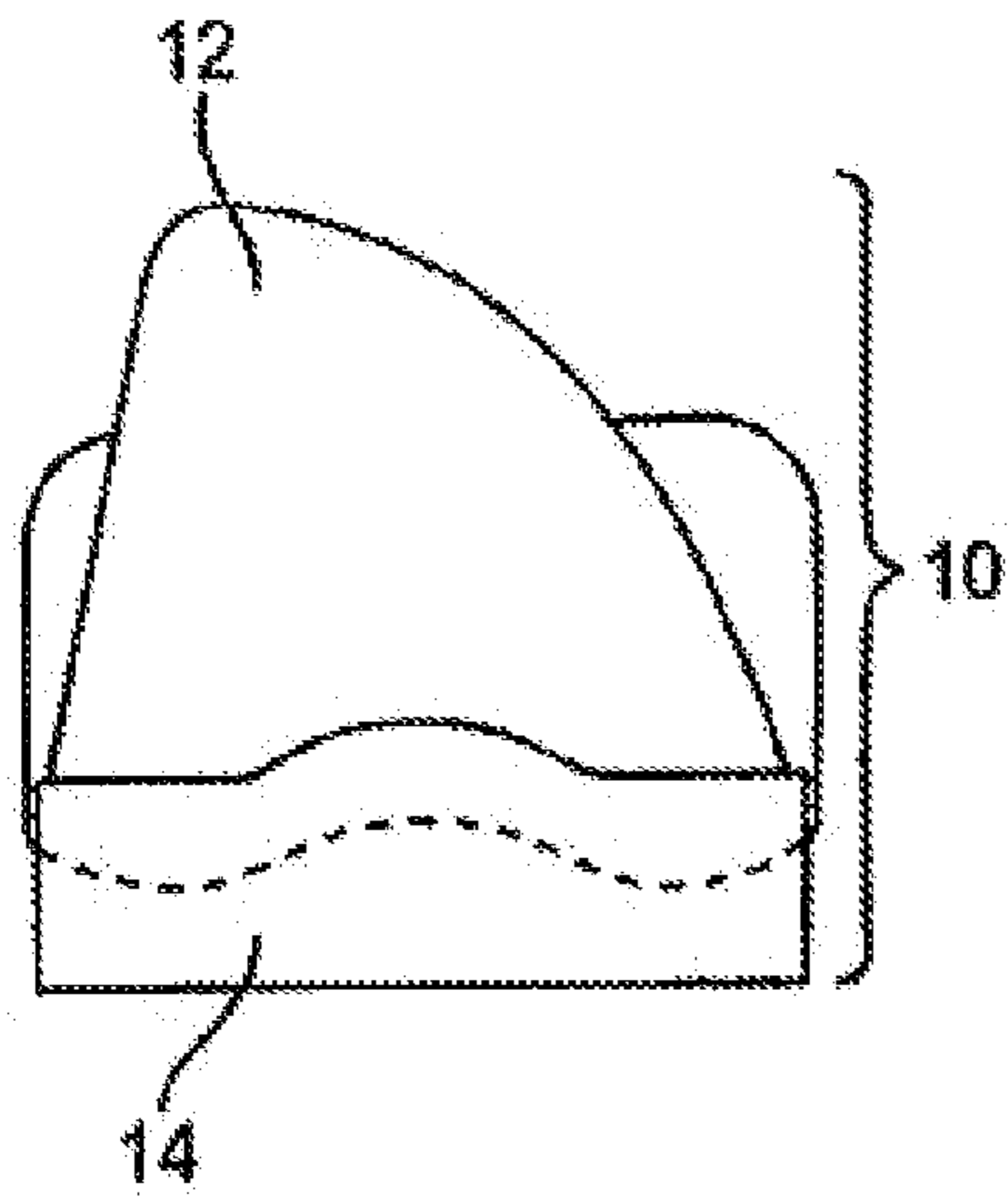

Figure 3A

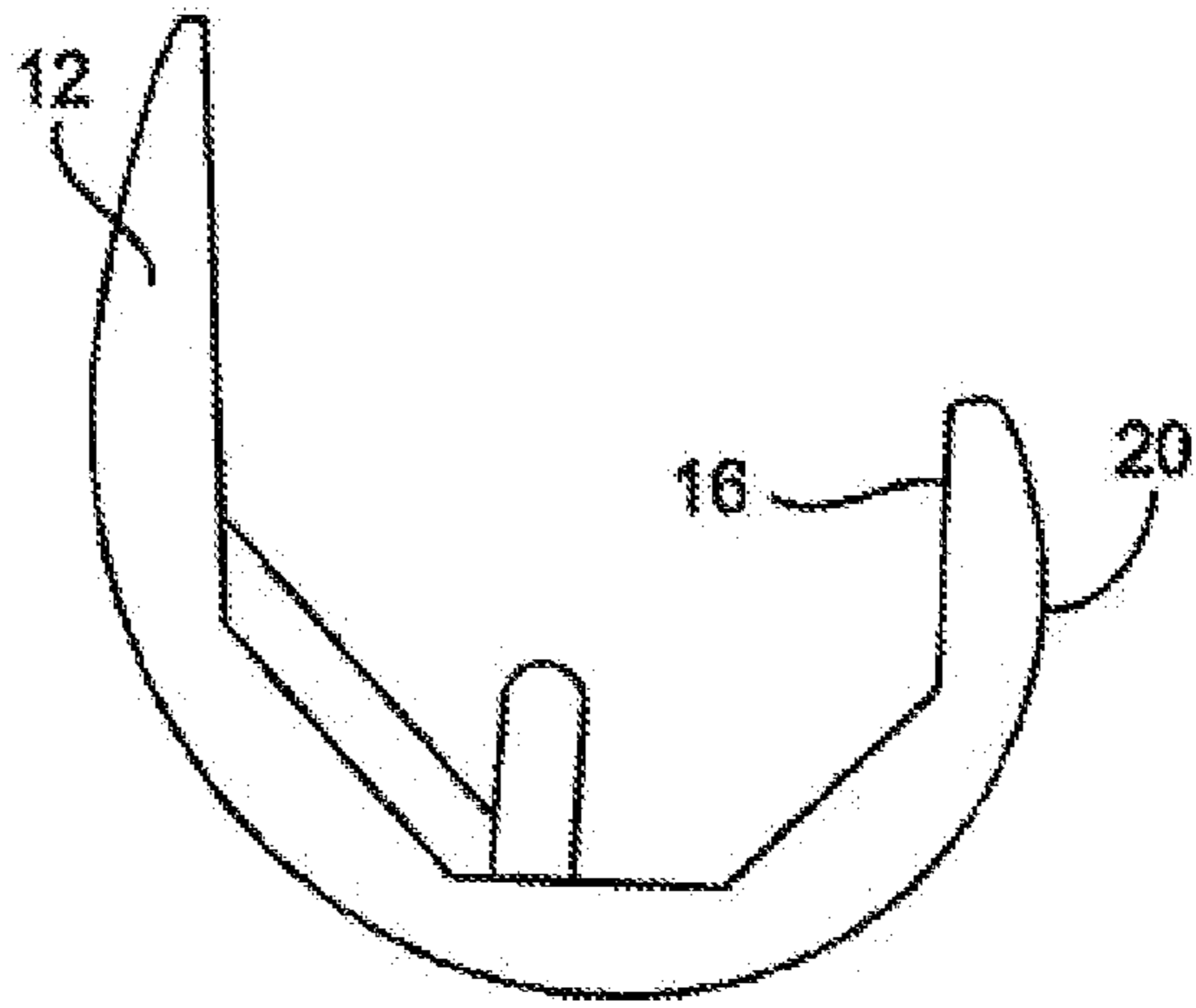

Figure 3B

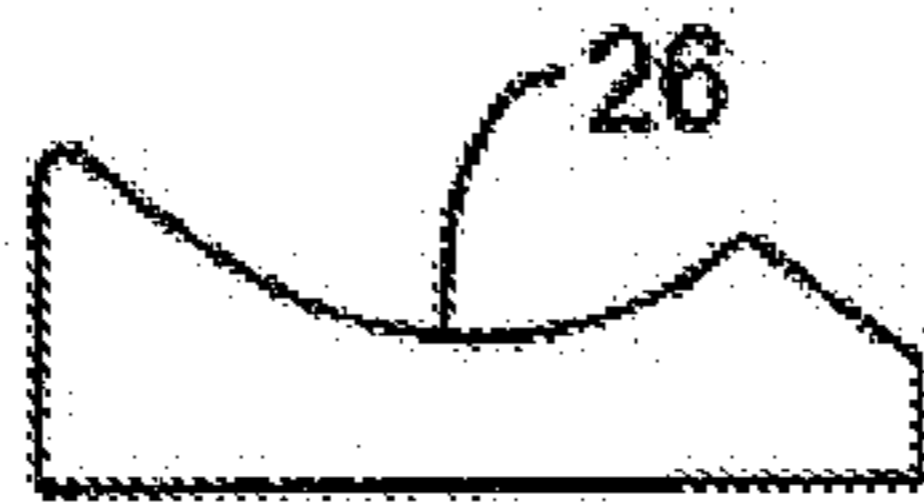

Figure 3C

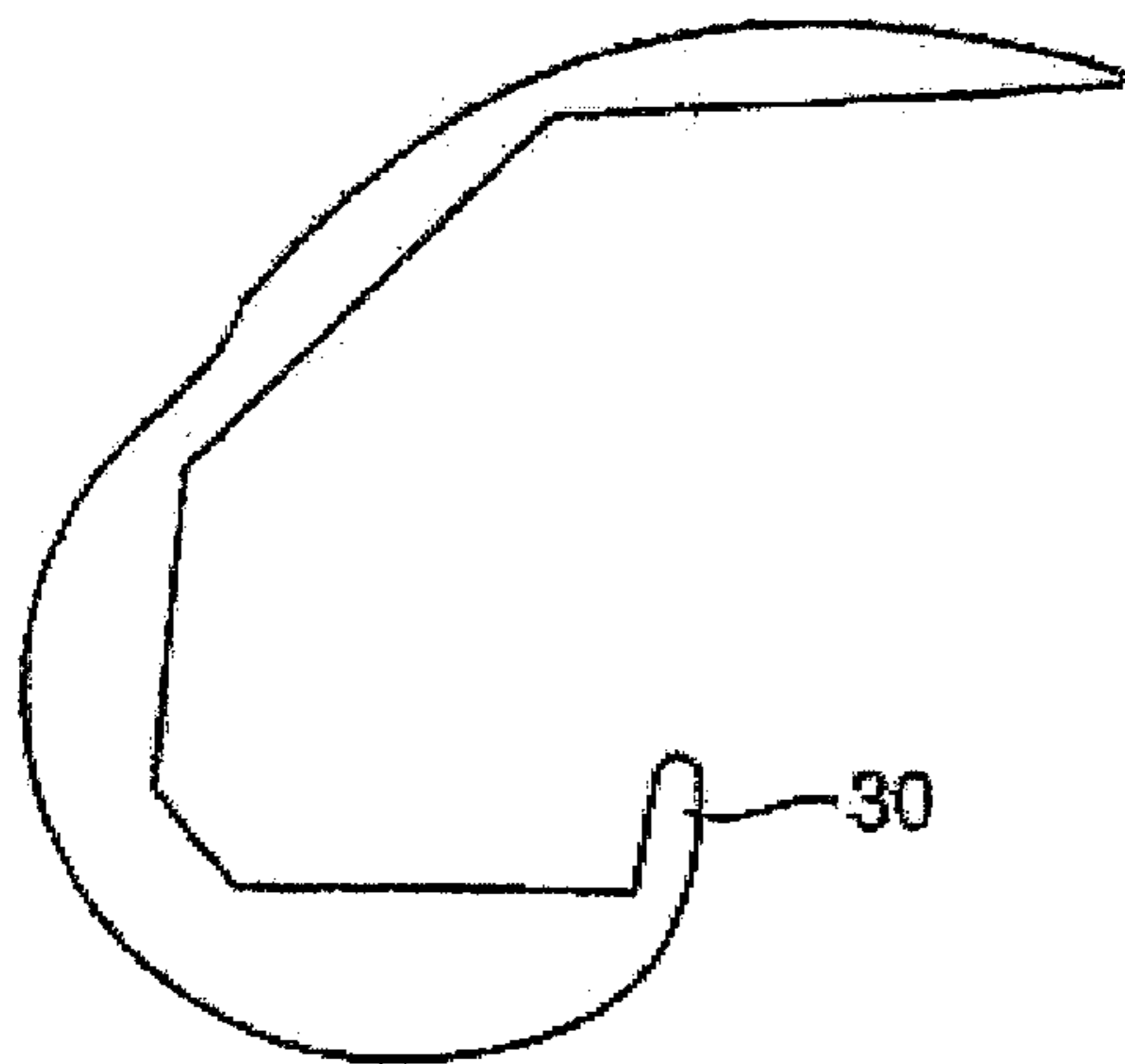

Figure 4A

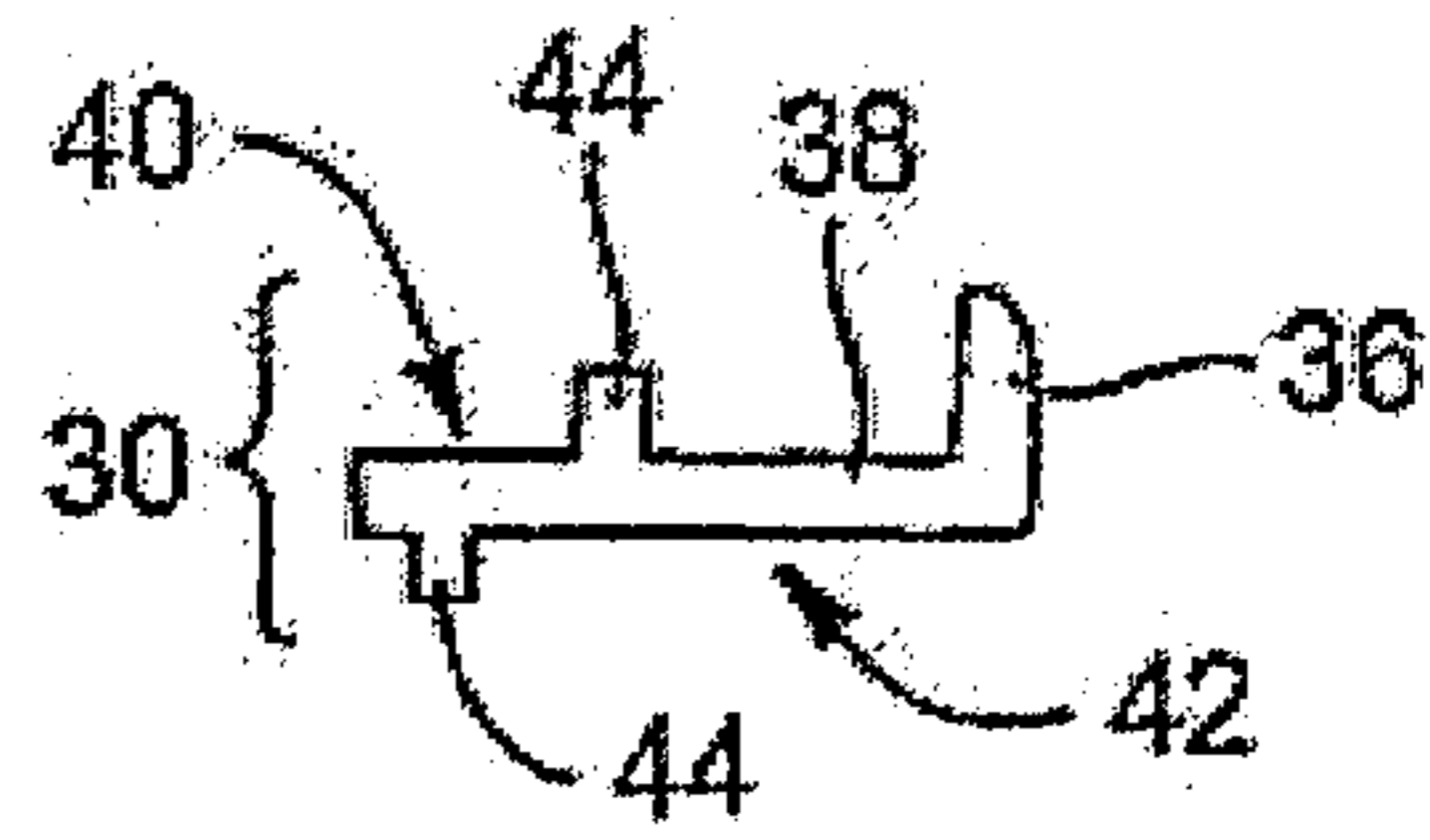

Figure 4B

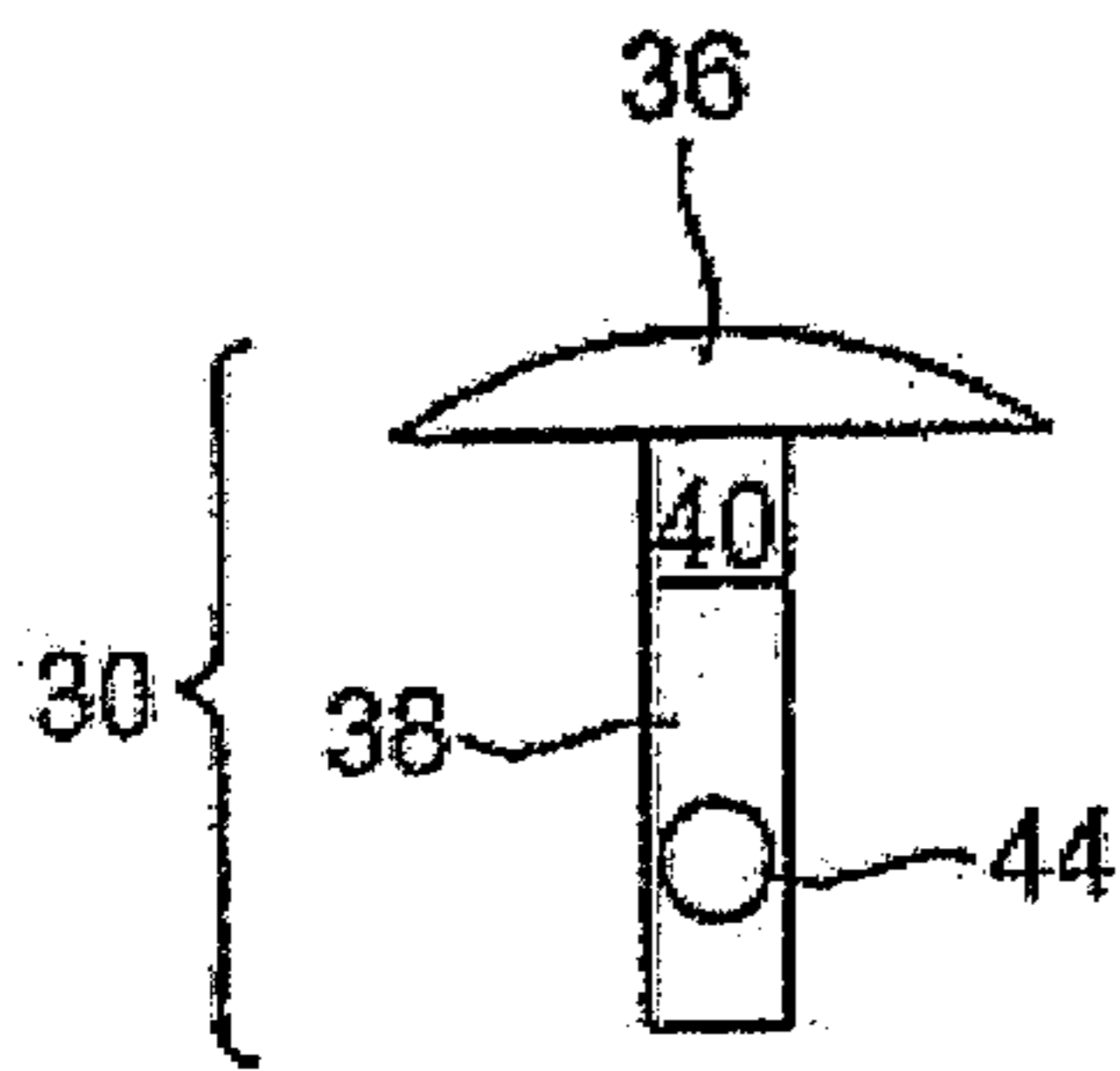

Figure 4C

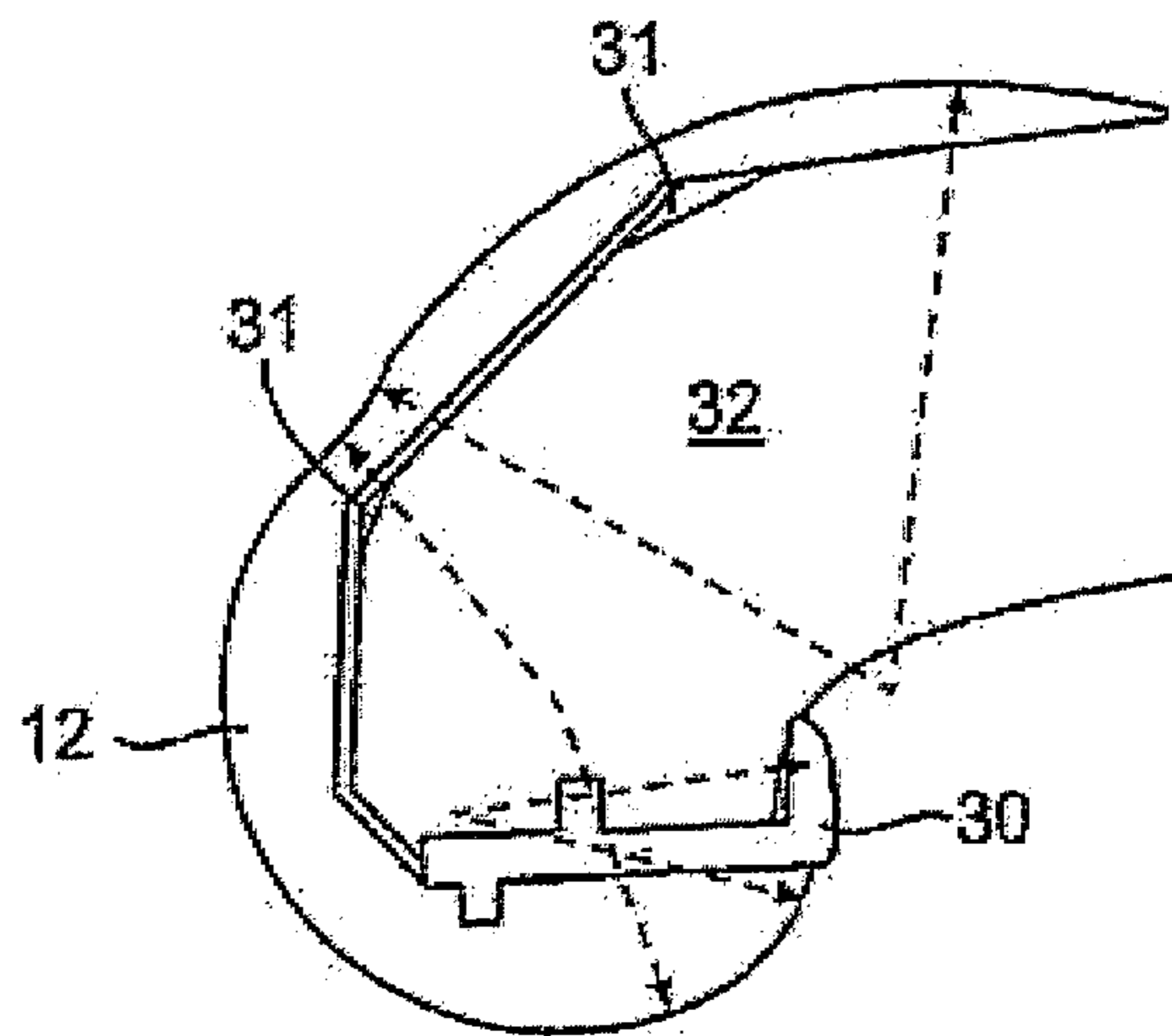

Figure 4D

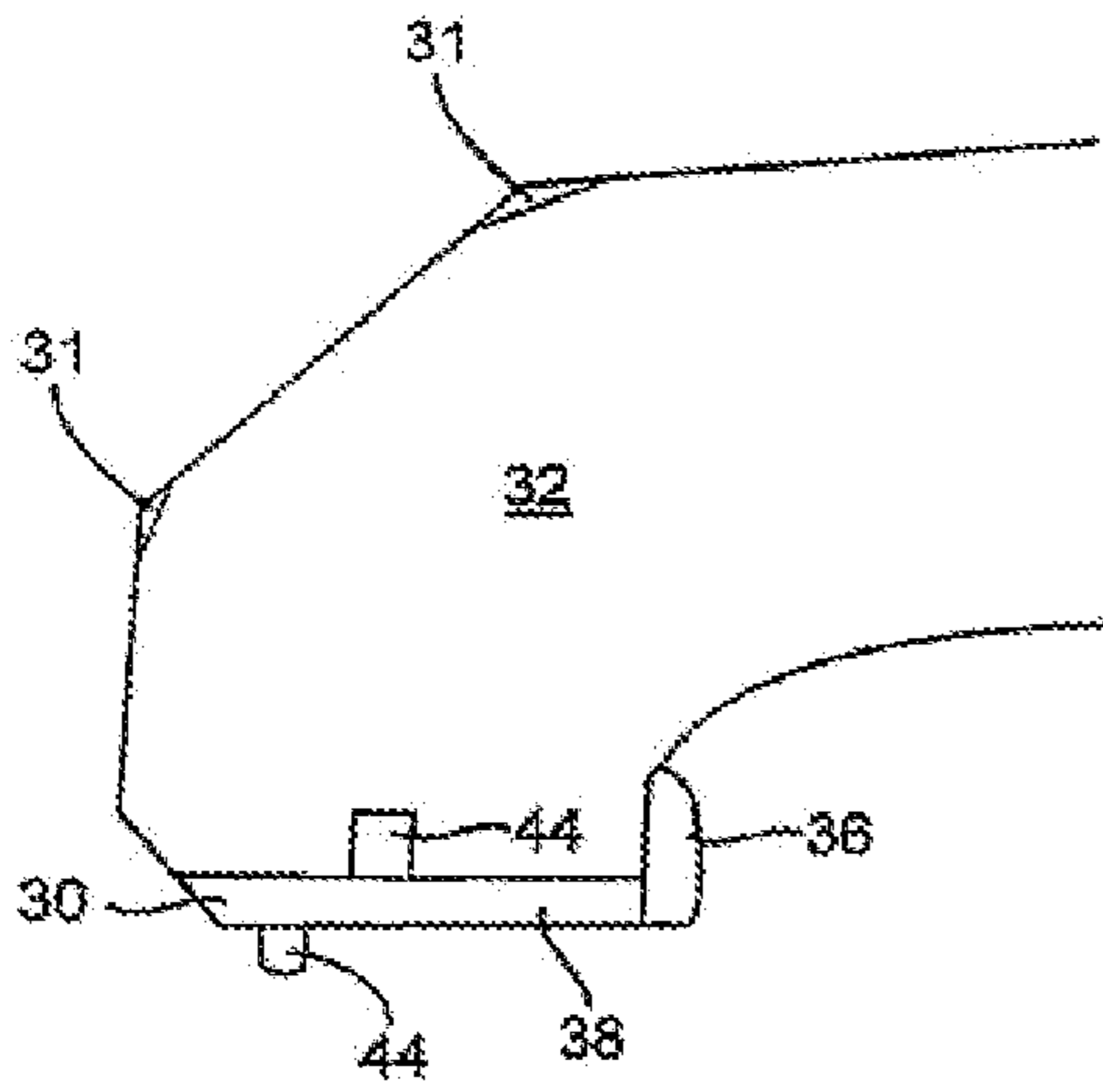

Figure 5A

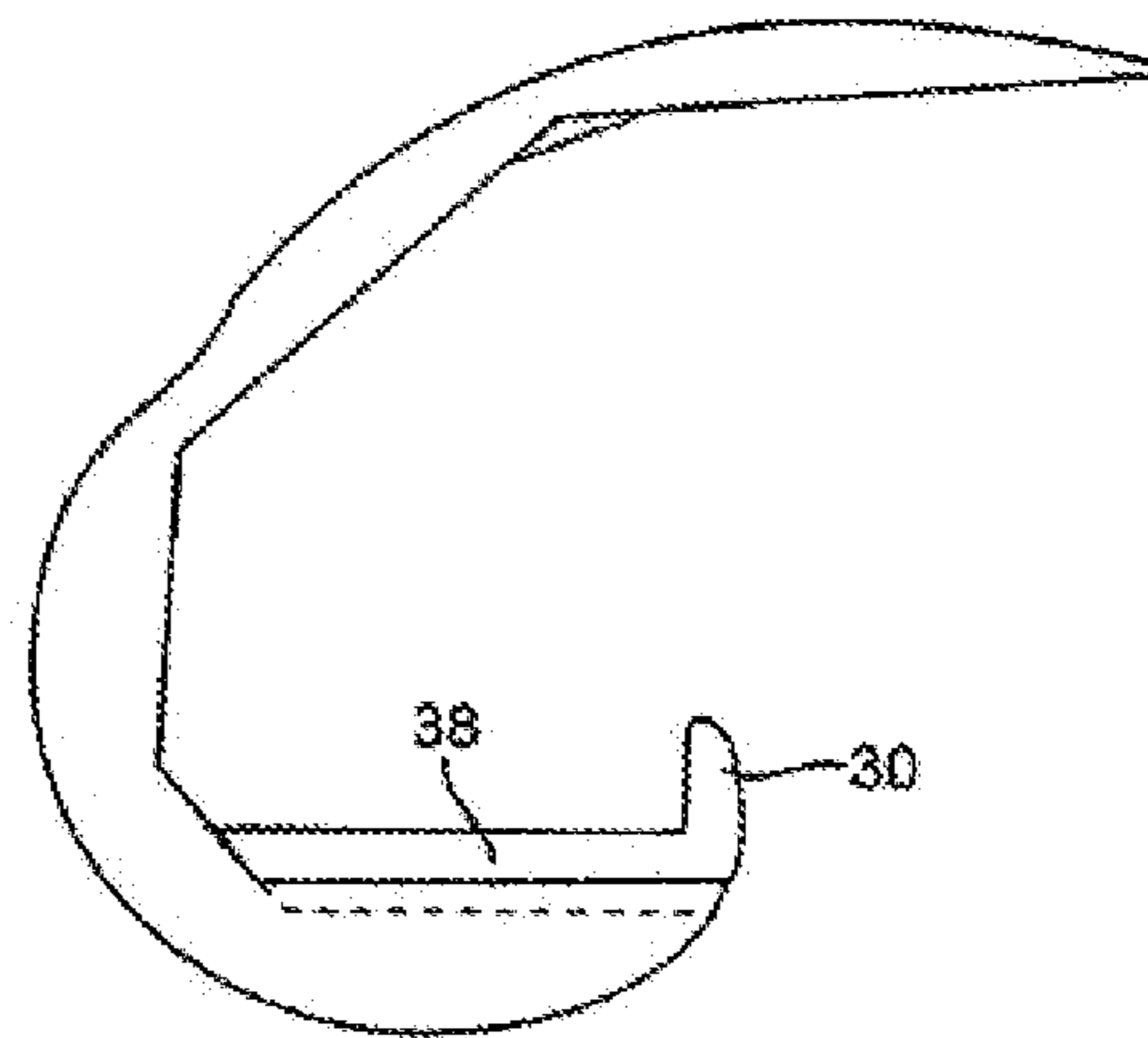

Figure 5B

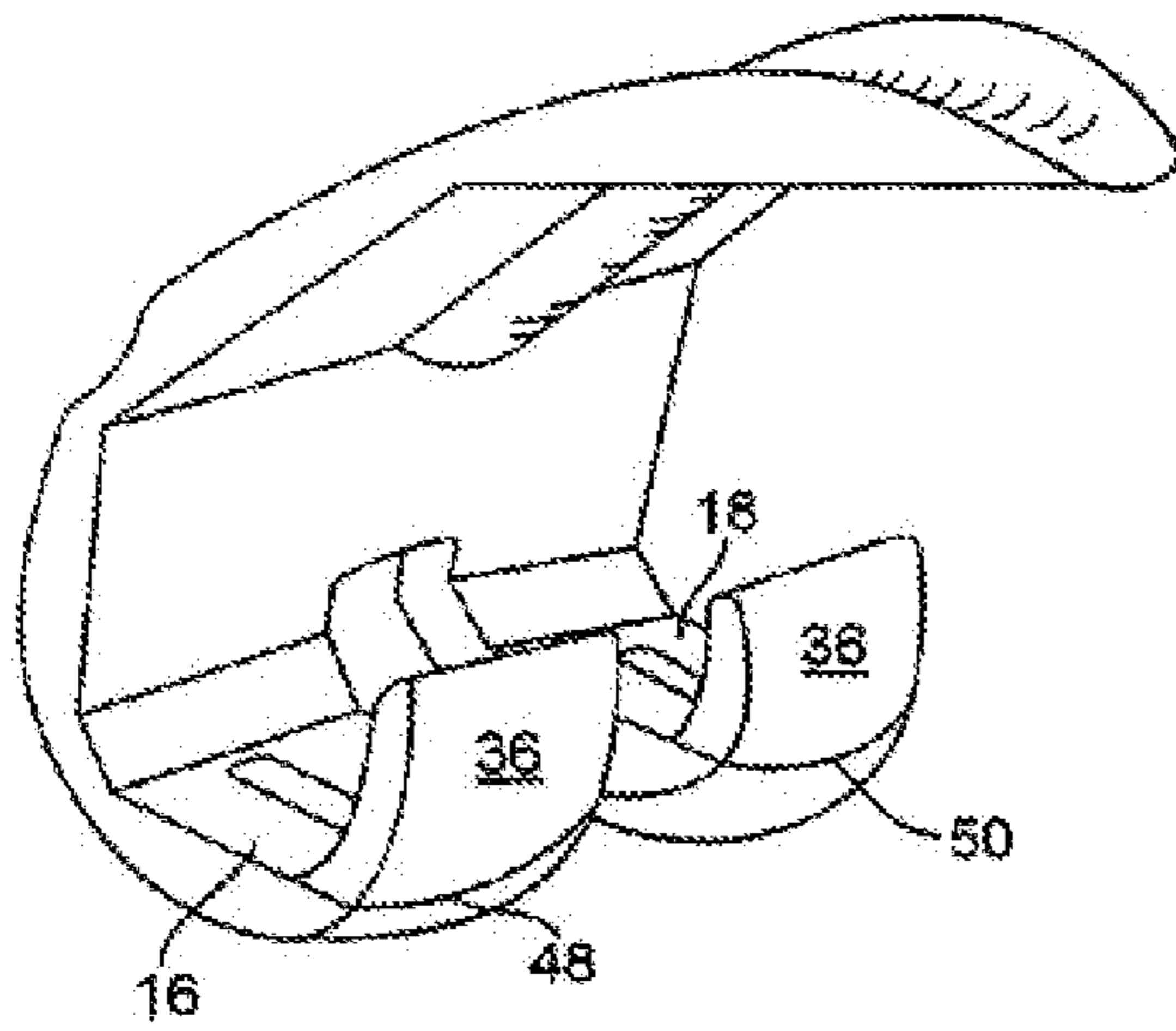

Figure 5C

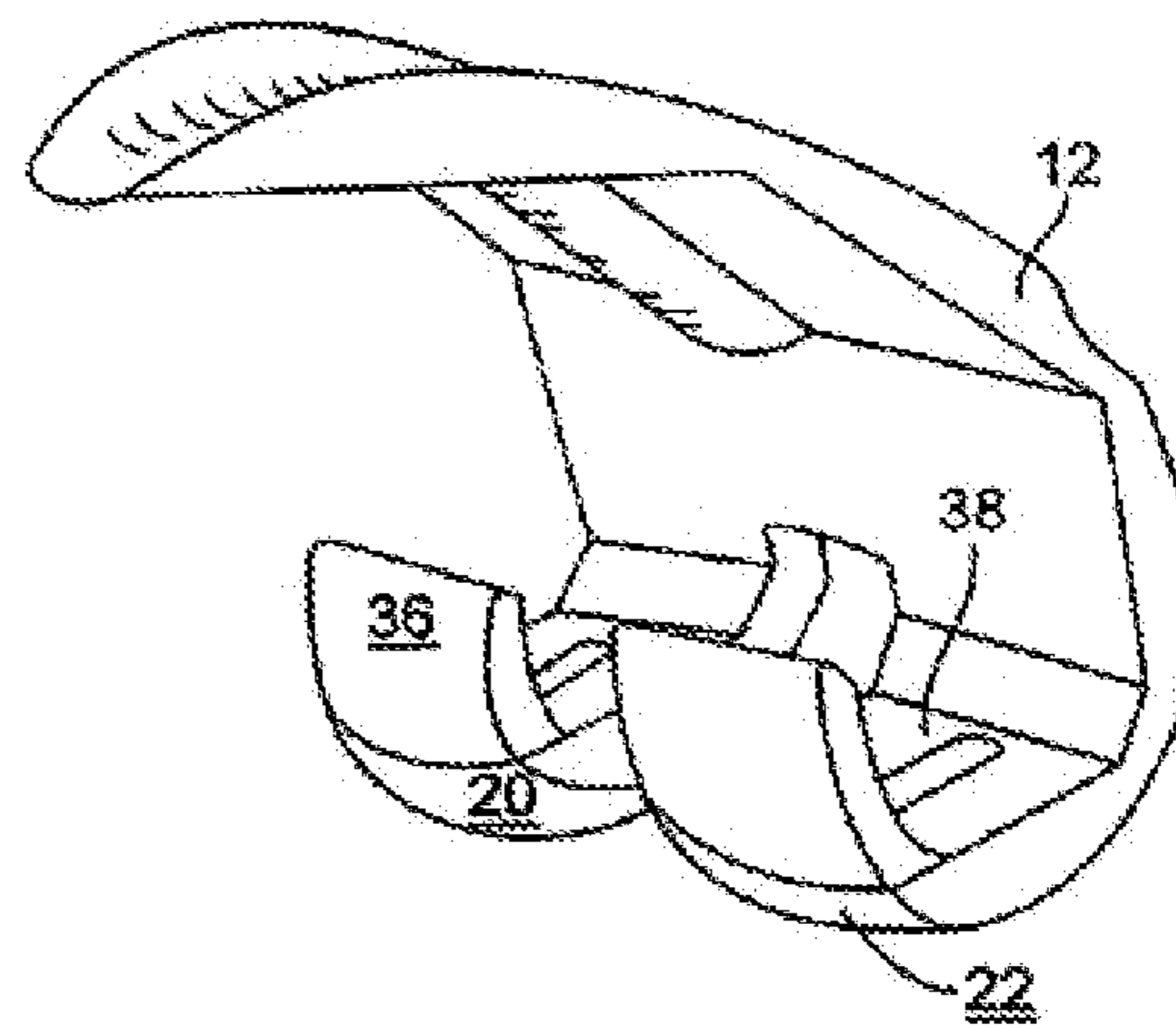

Figure 5D

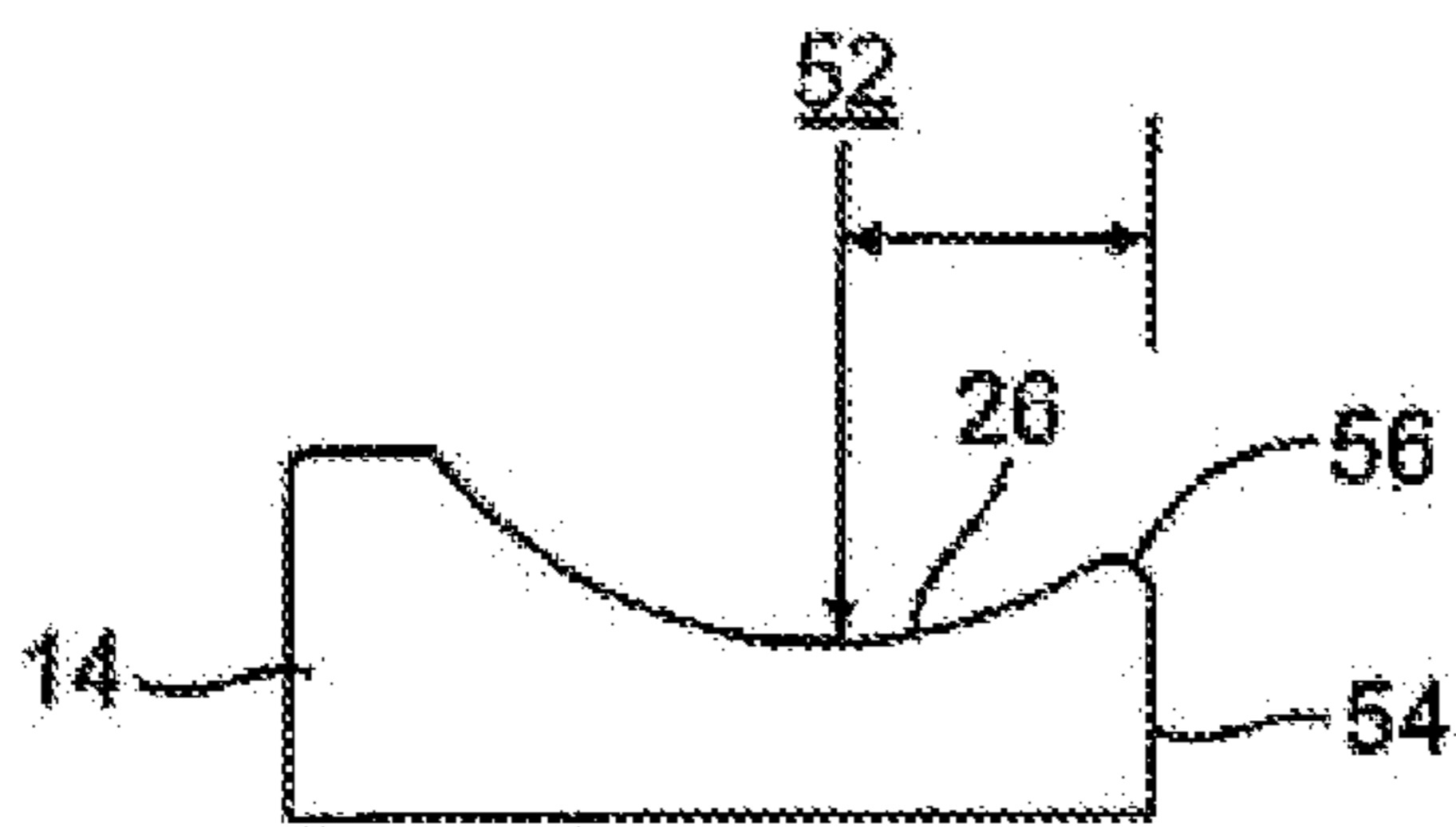

Figure 6A

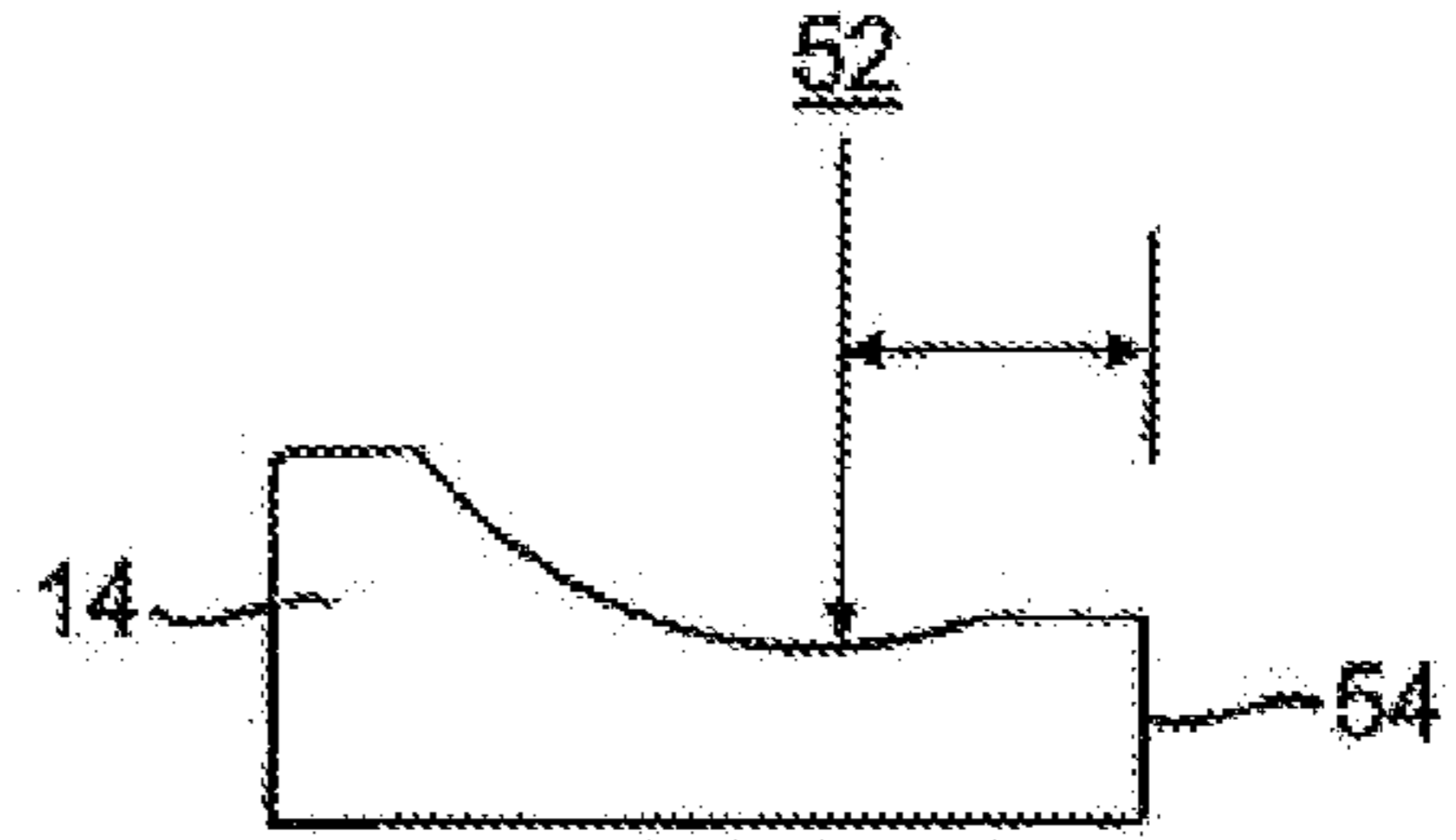

Figure 6B

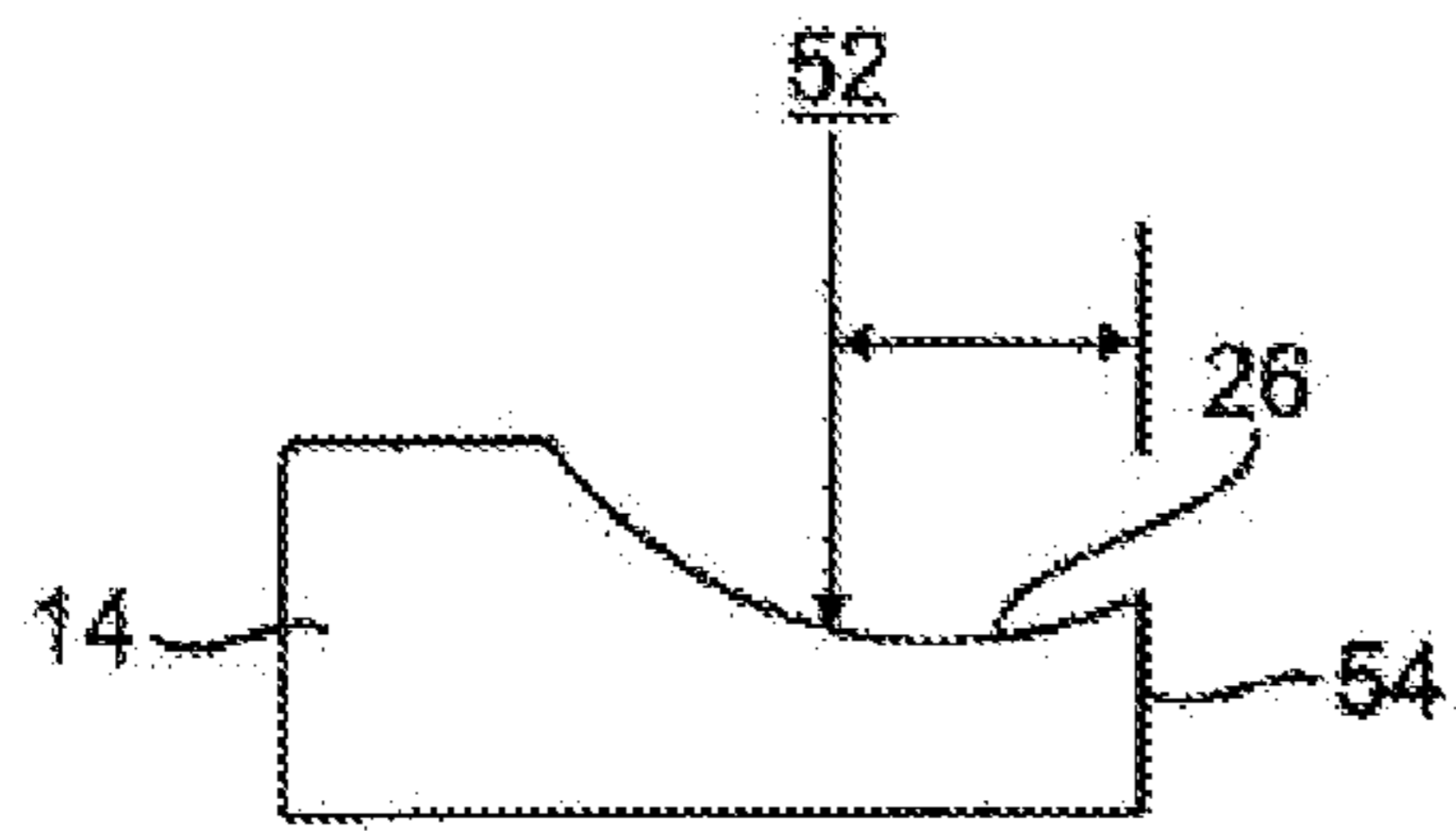

Figure 6C

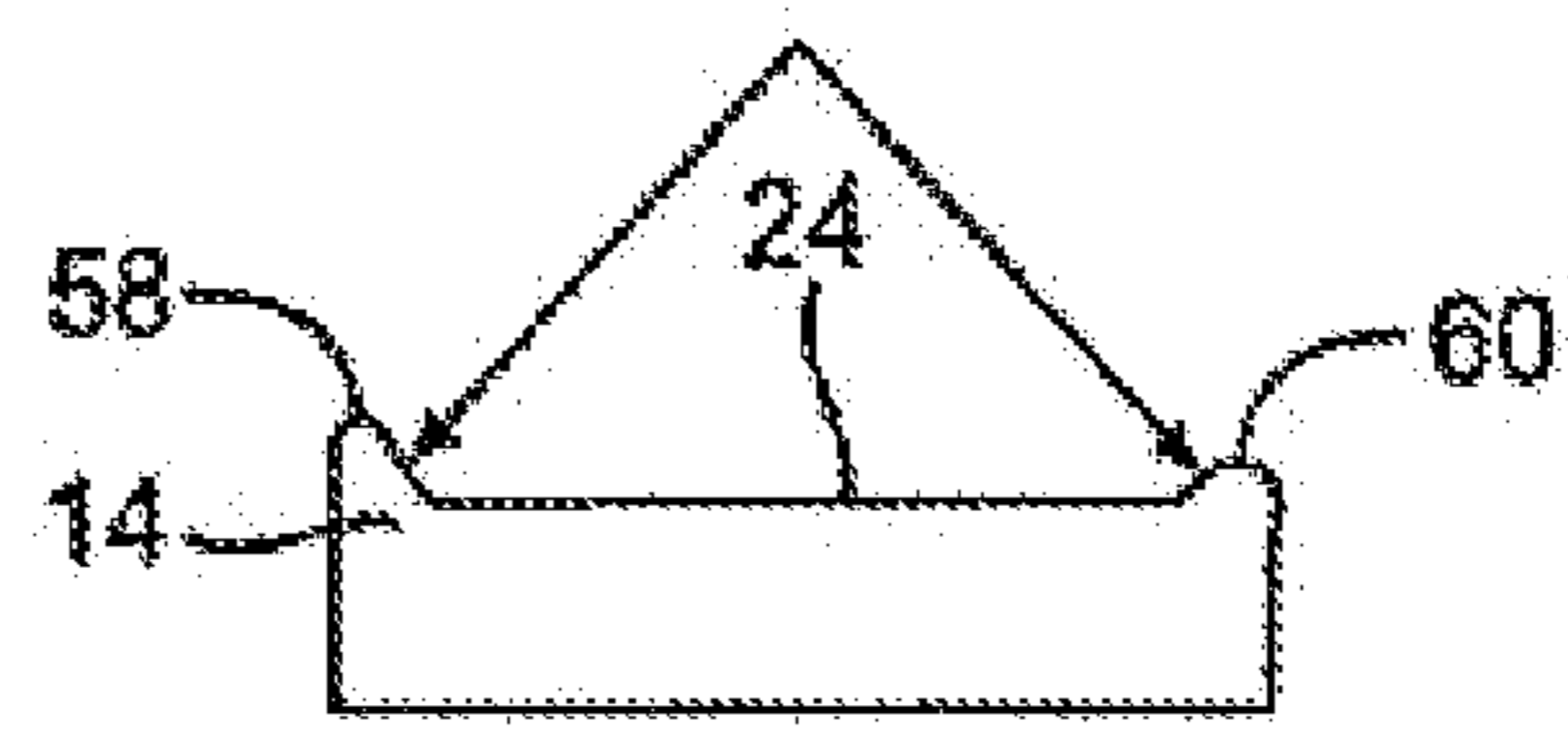

Figure 6D

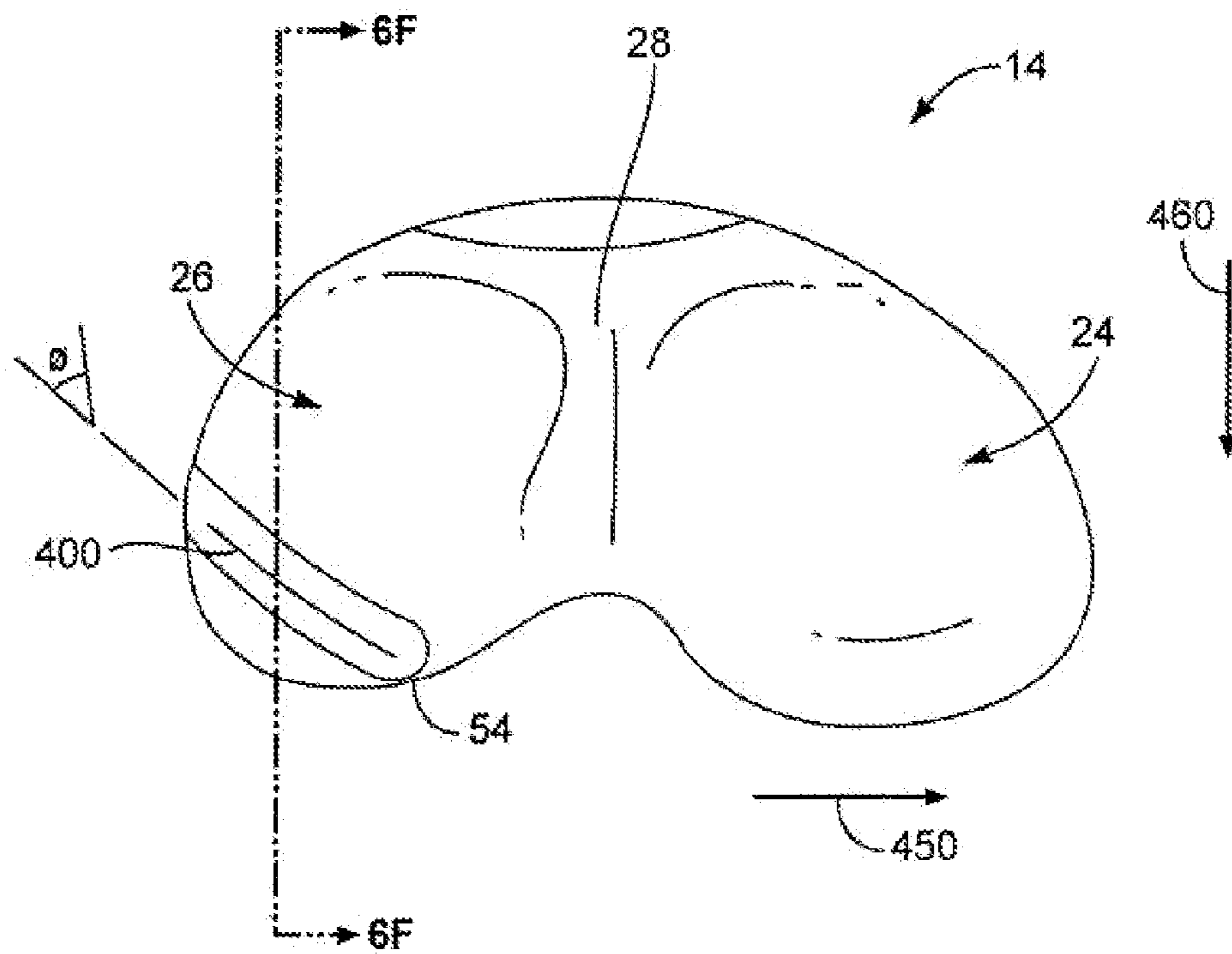

Figure 6E

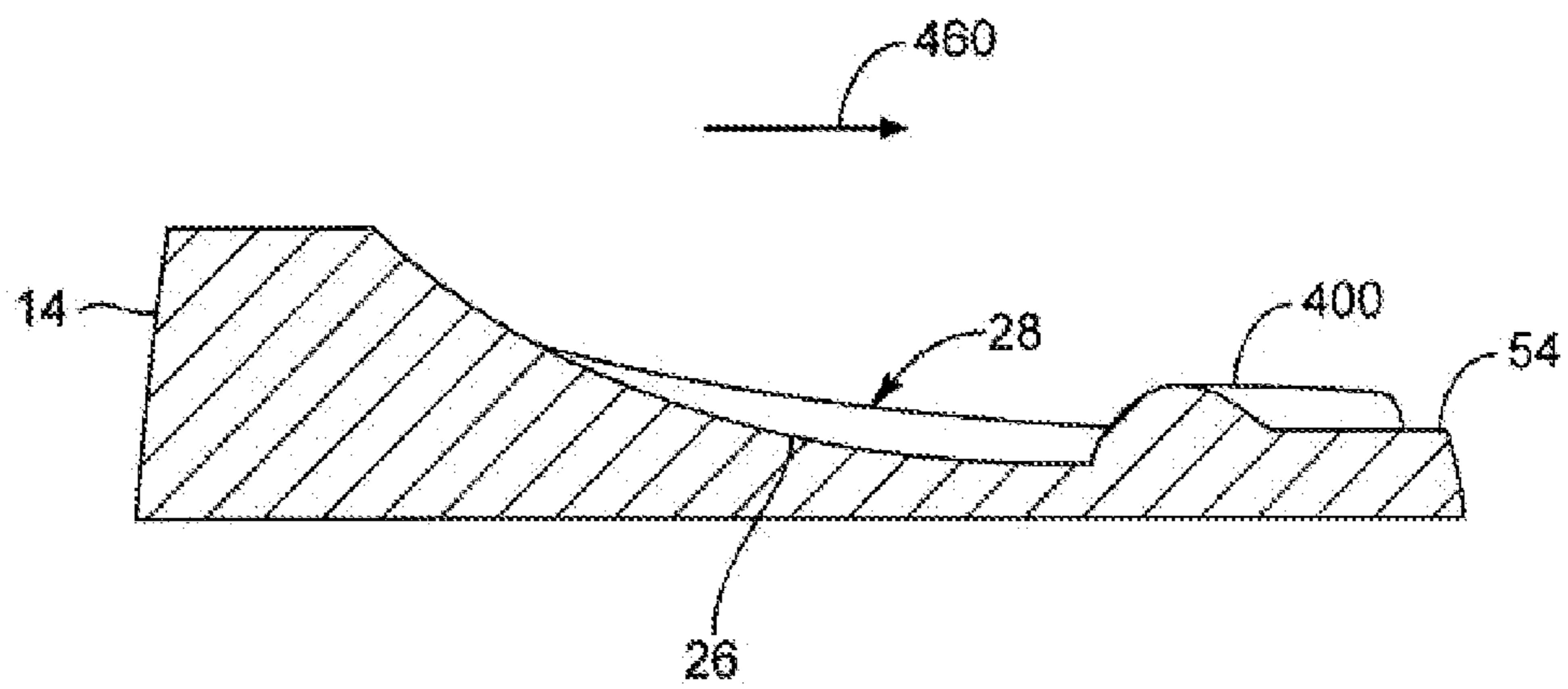

Figure 6F

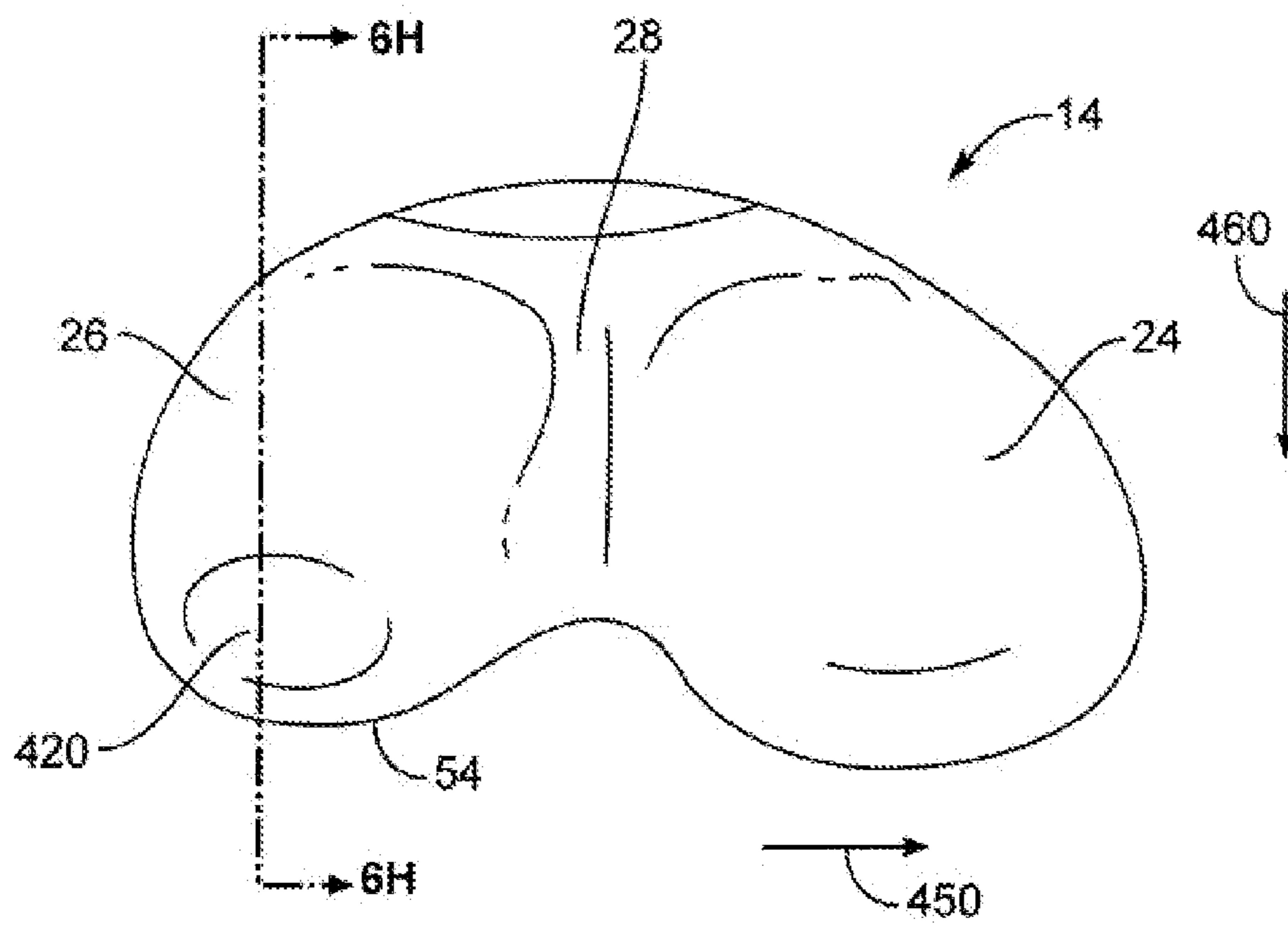

Figure 6G

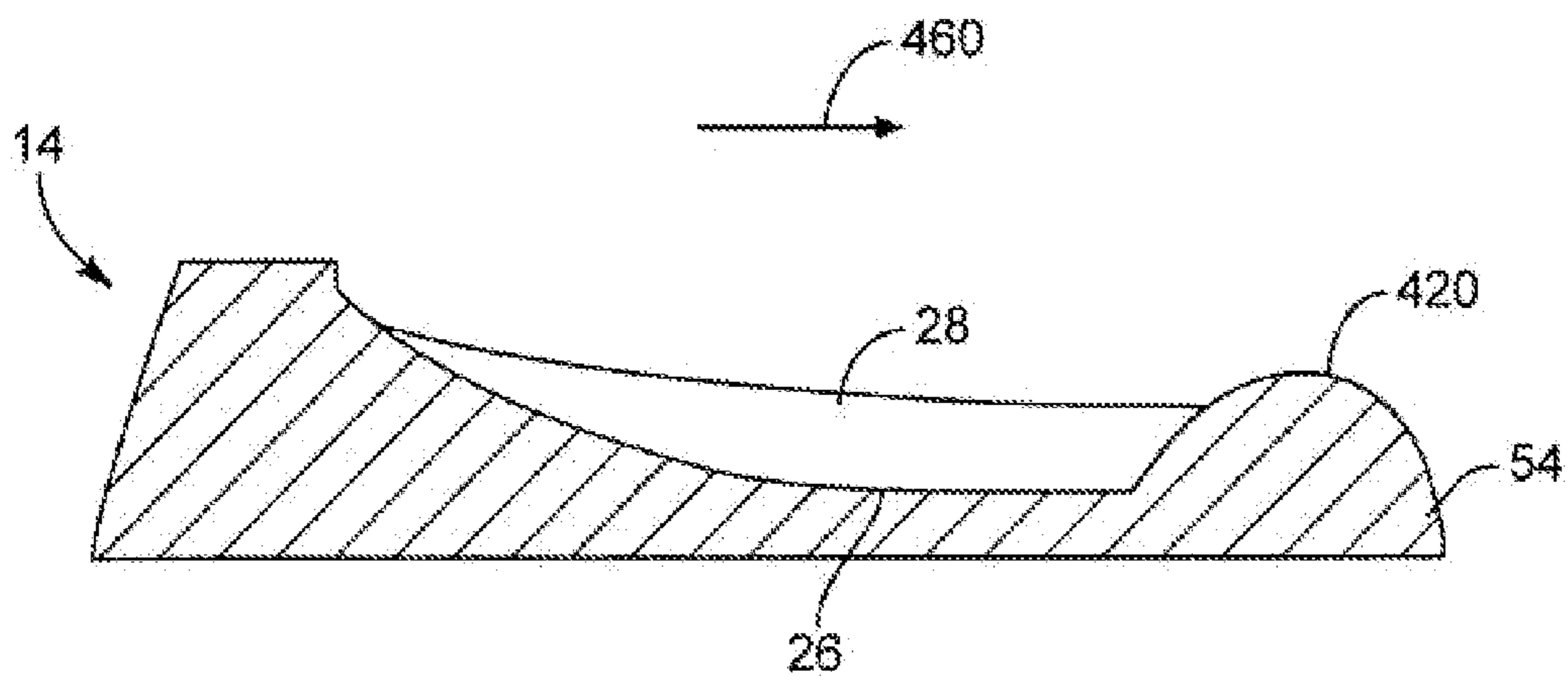

Figure 6H

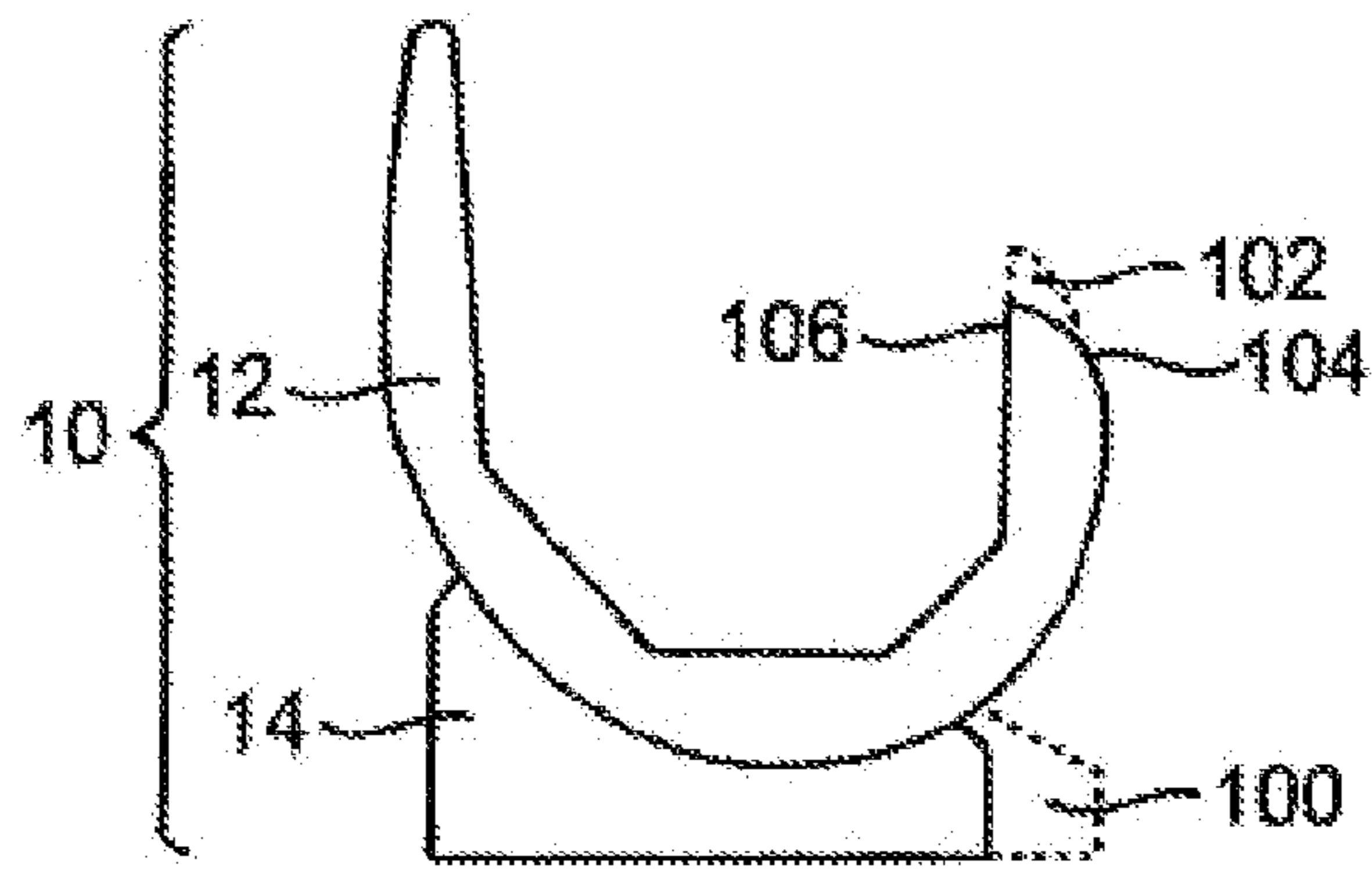

Figure 7A

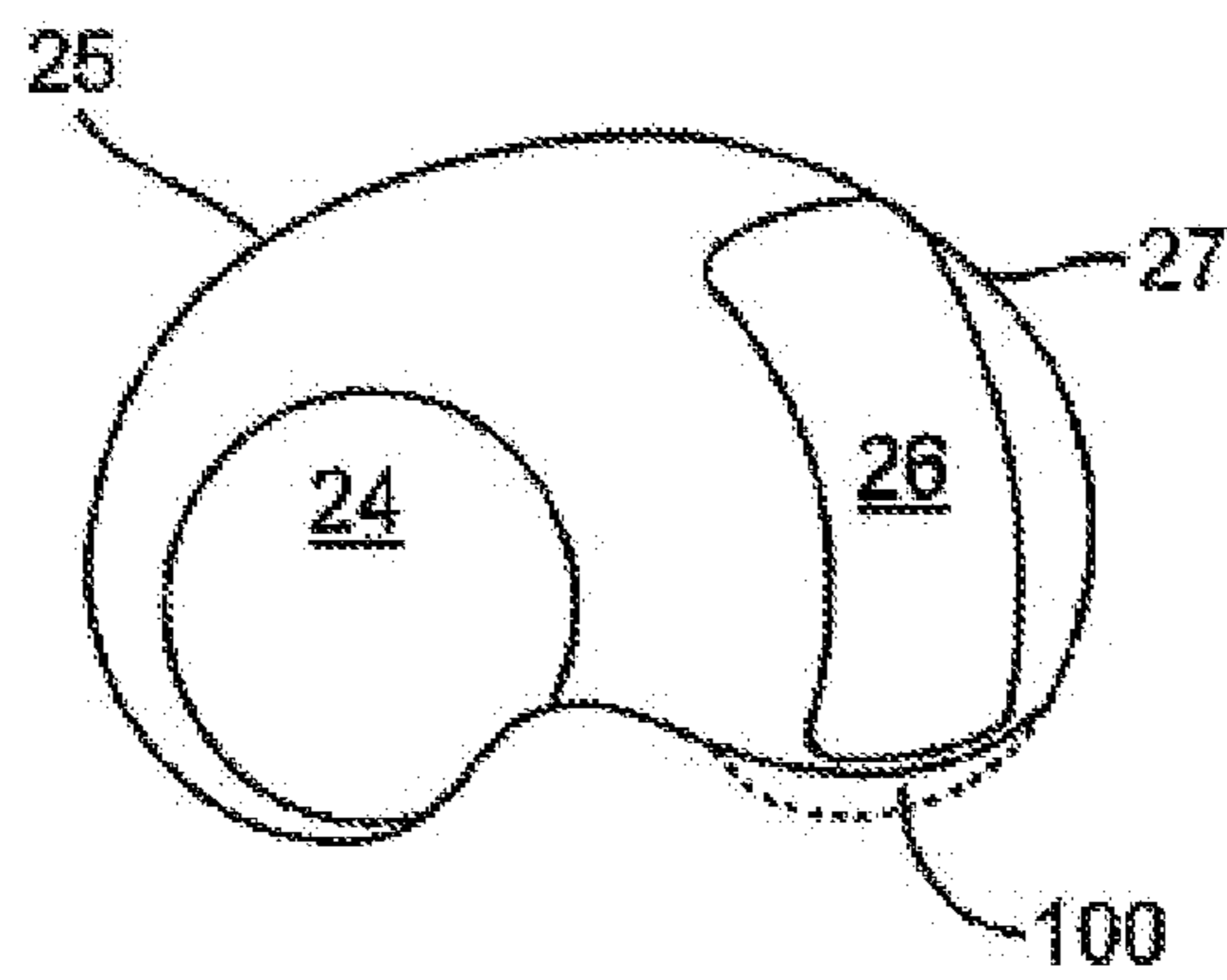

Figure 7B

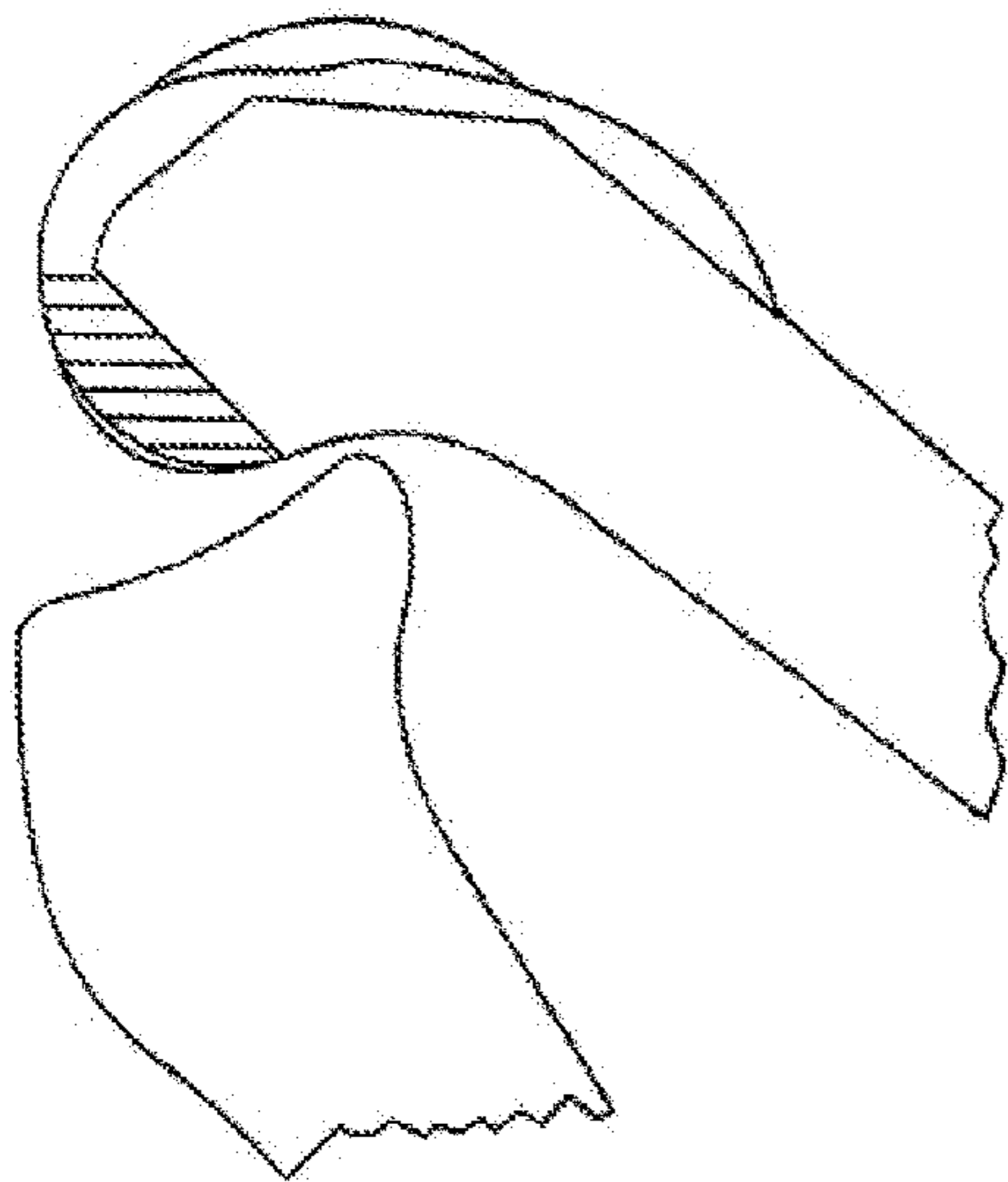

Figure 8A

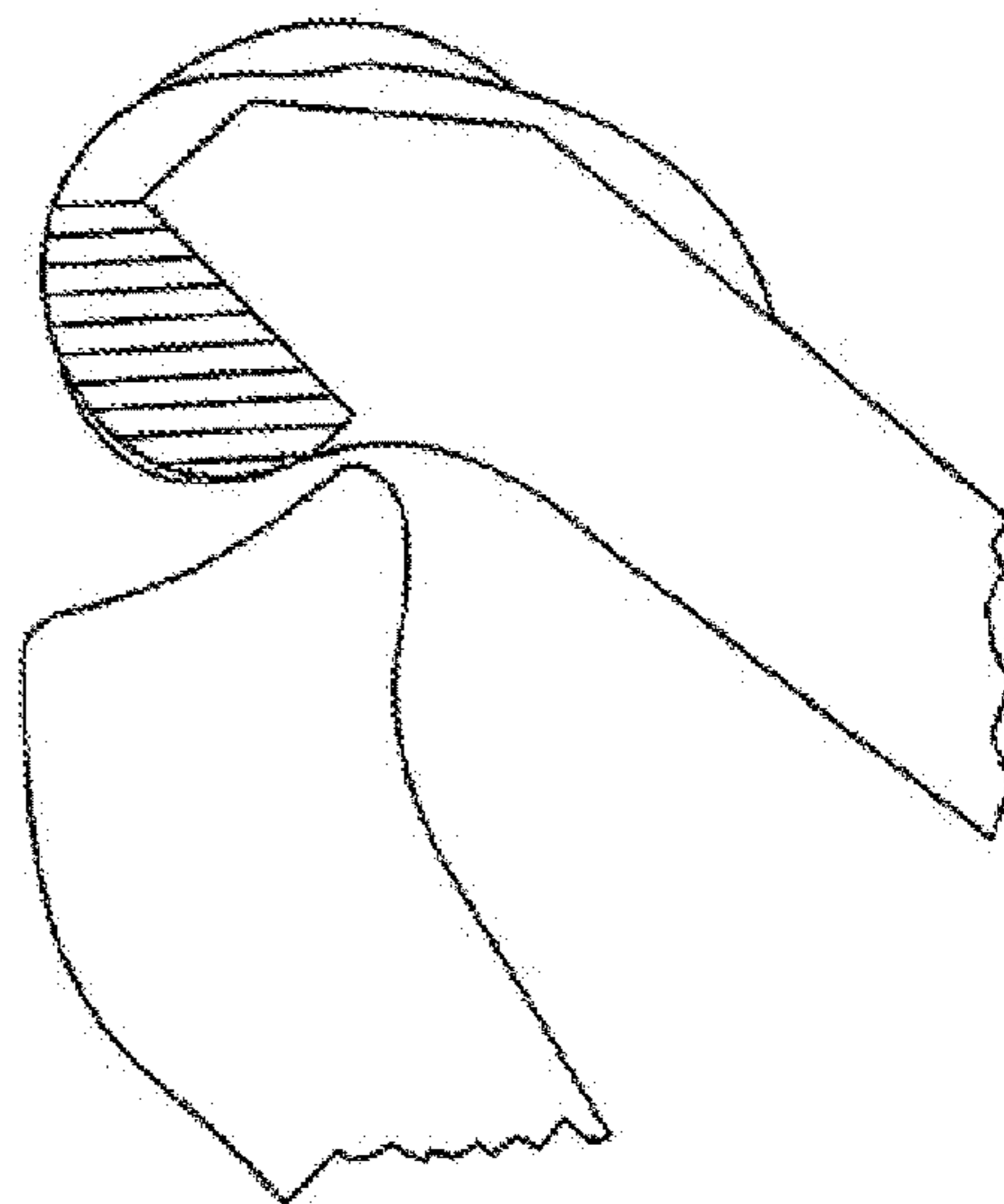

Figure 8B

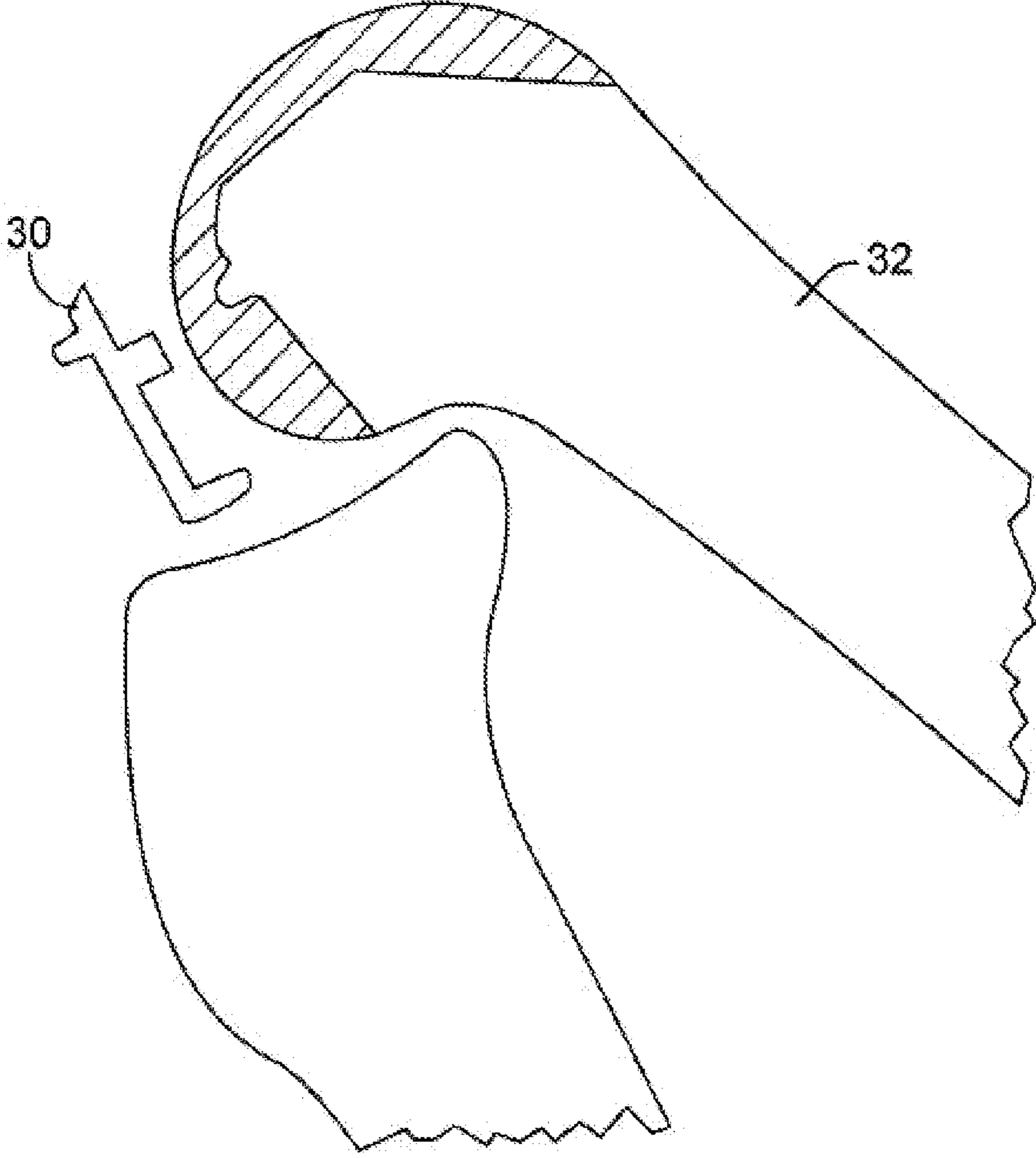

Figure 9

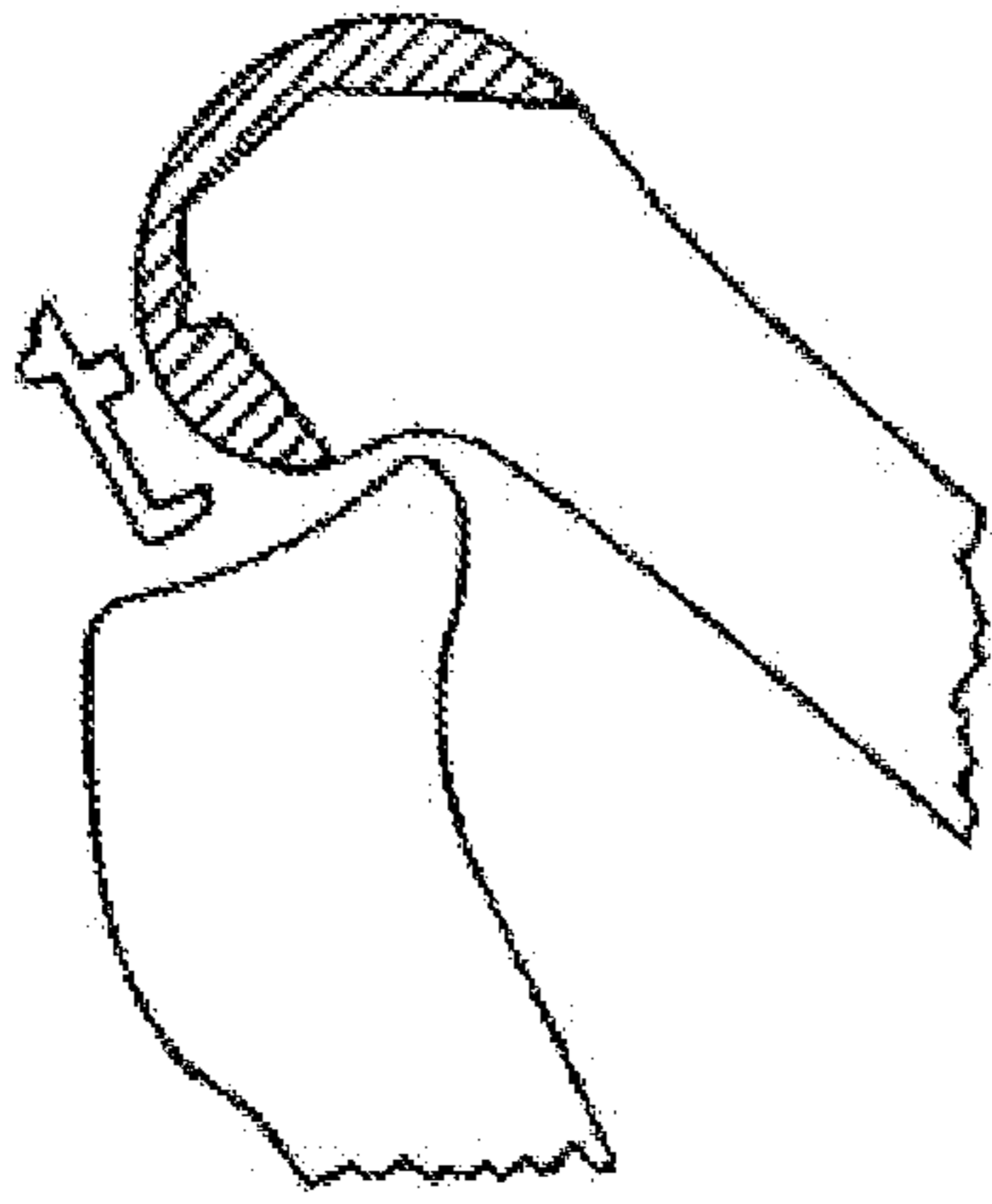

Figure 10A

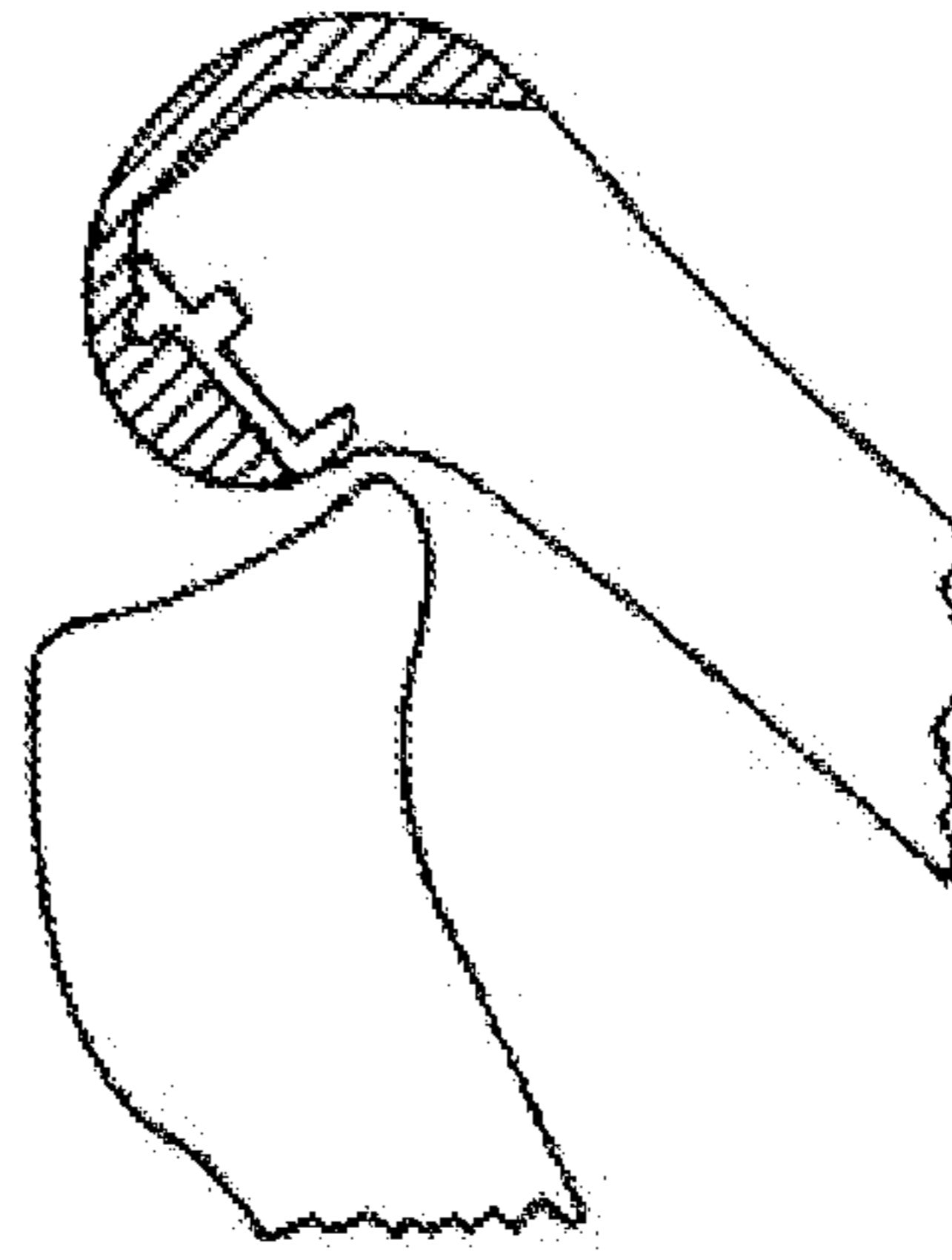

Figure 10B

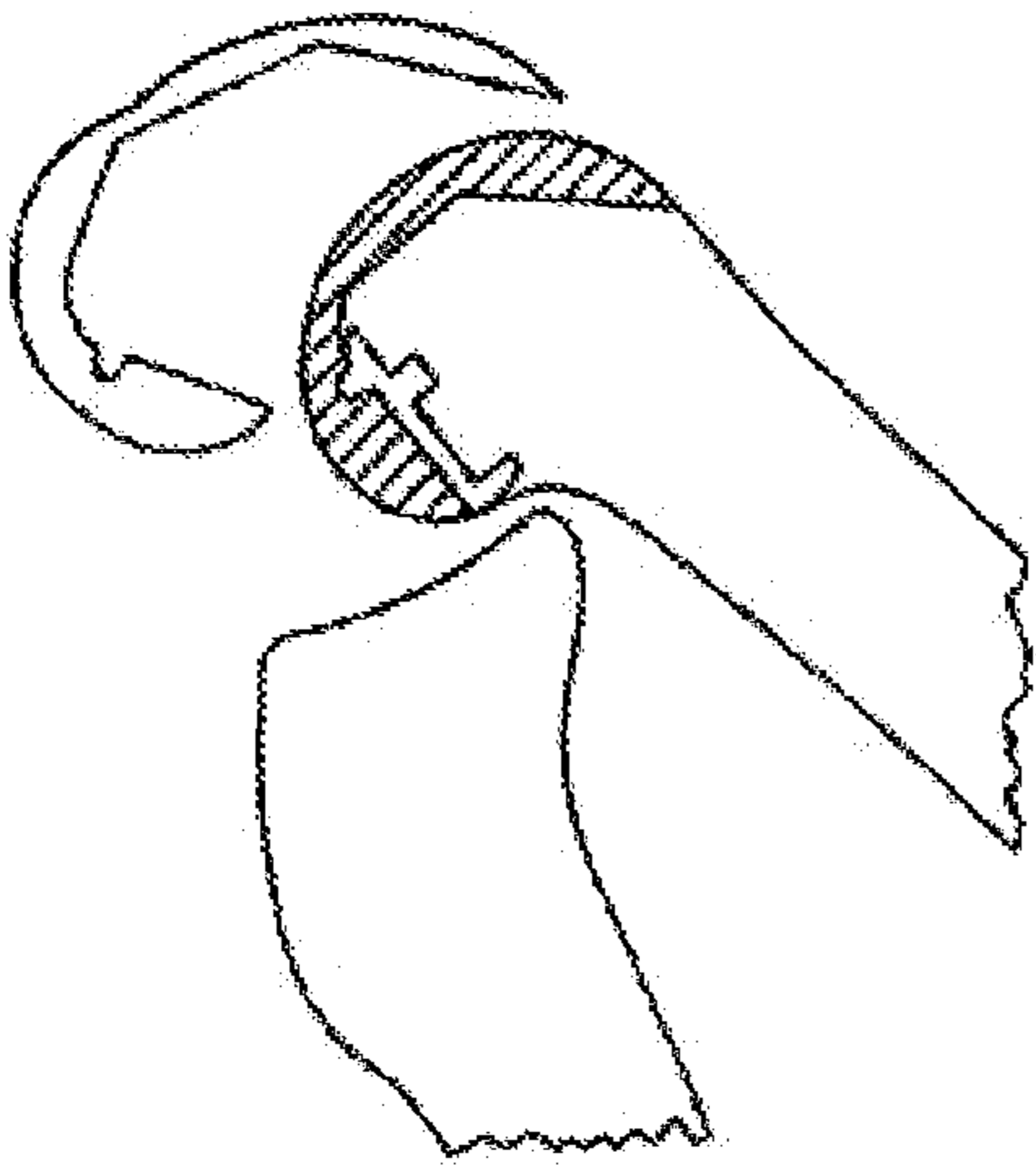

Figure 10C

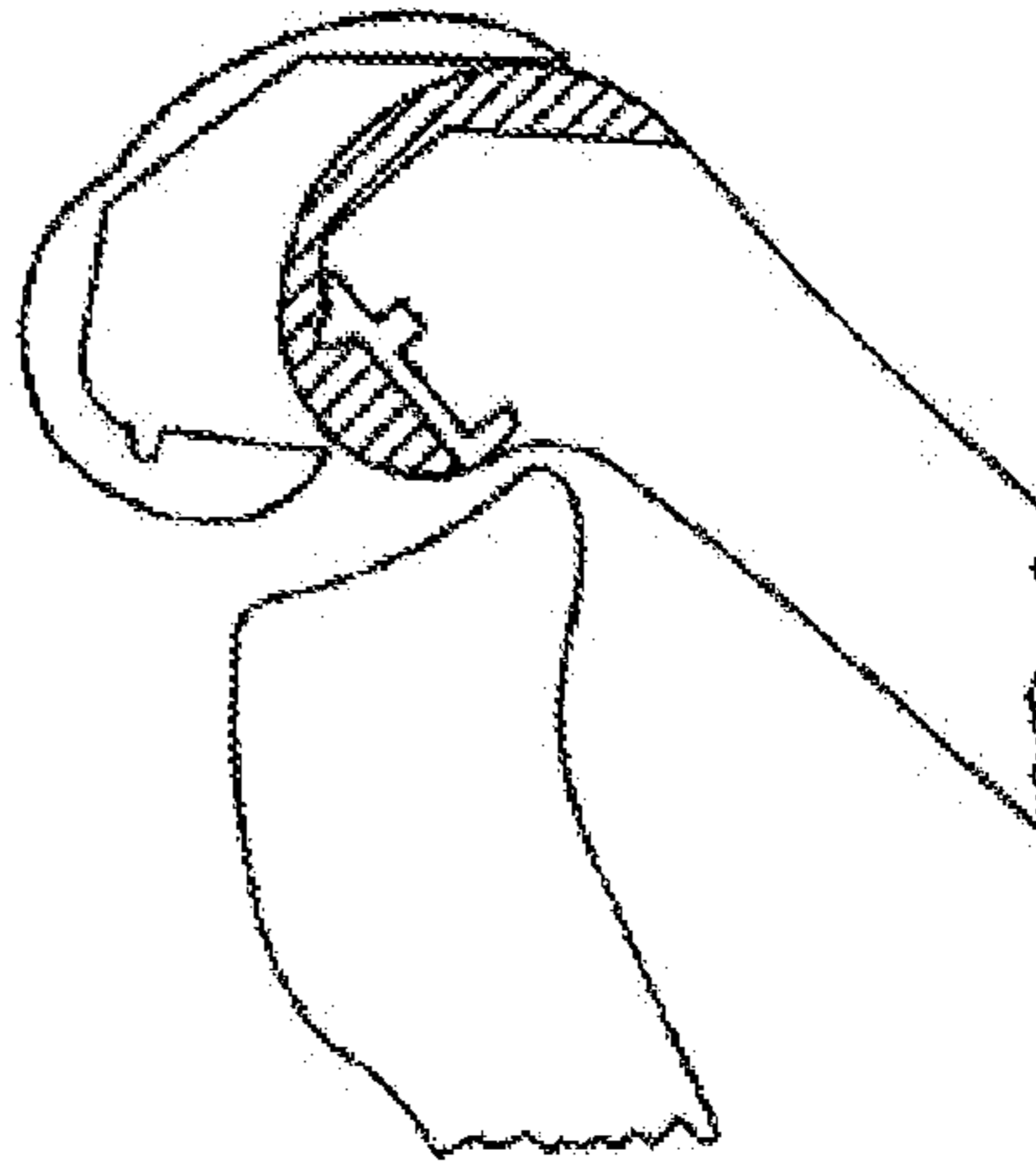

Figure 10D

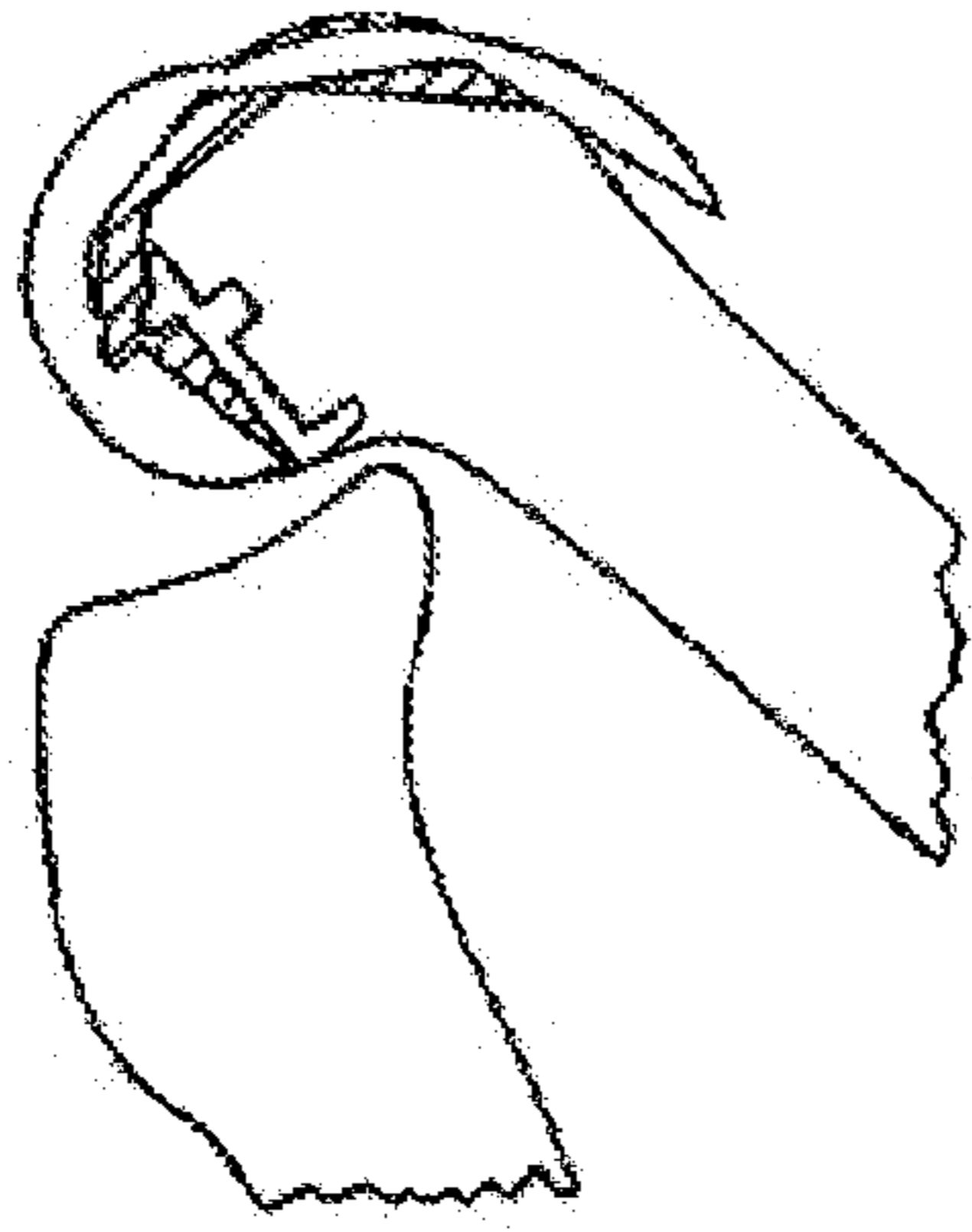

Figure 10E

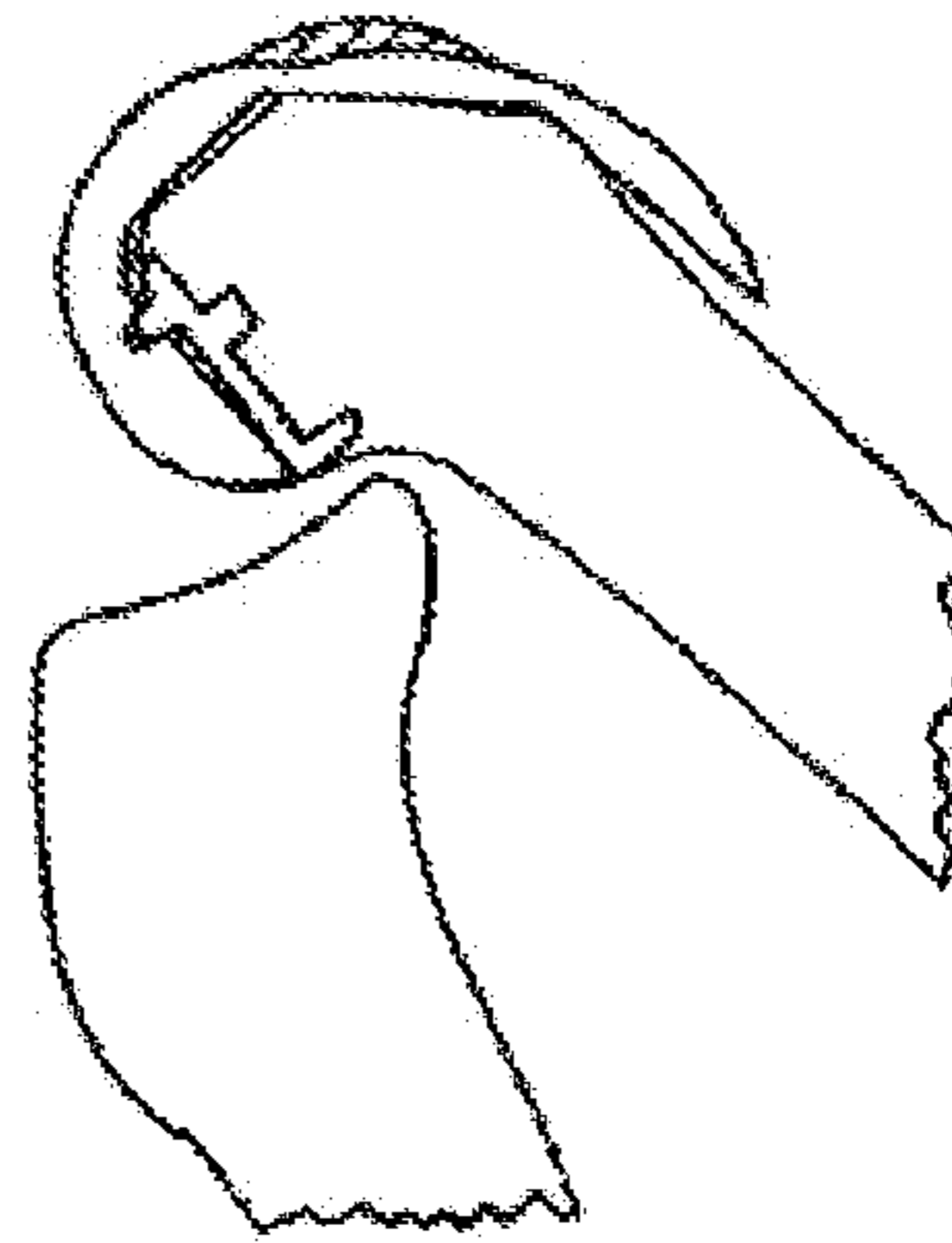

Figure 10F

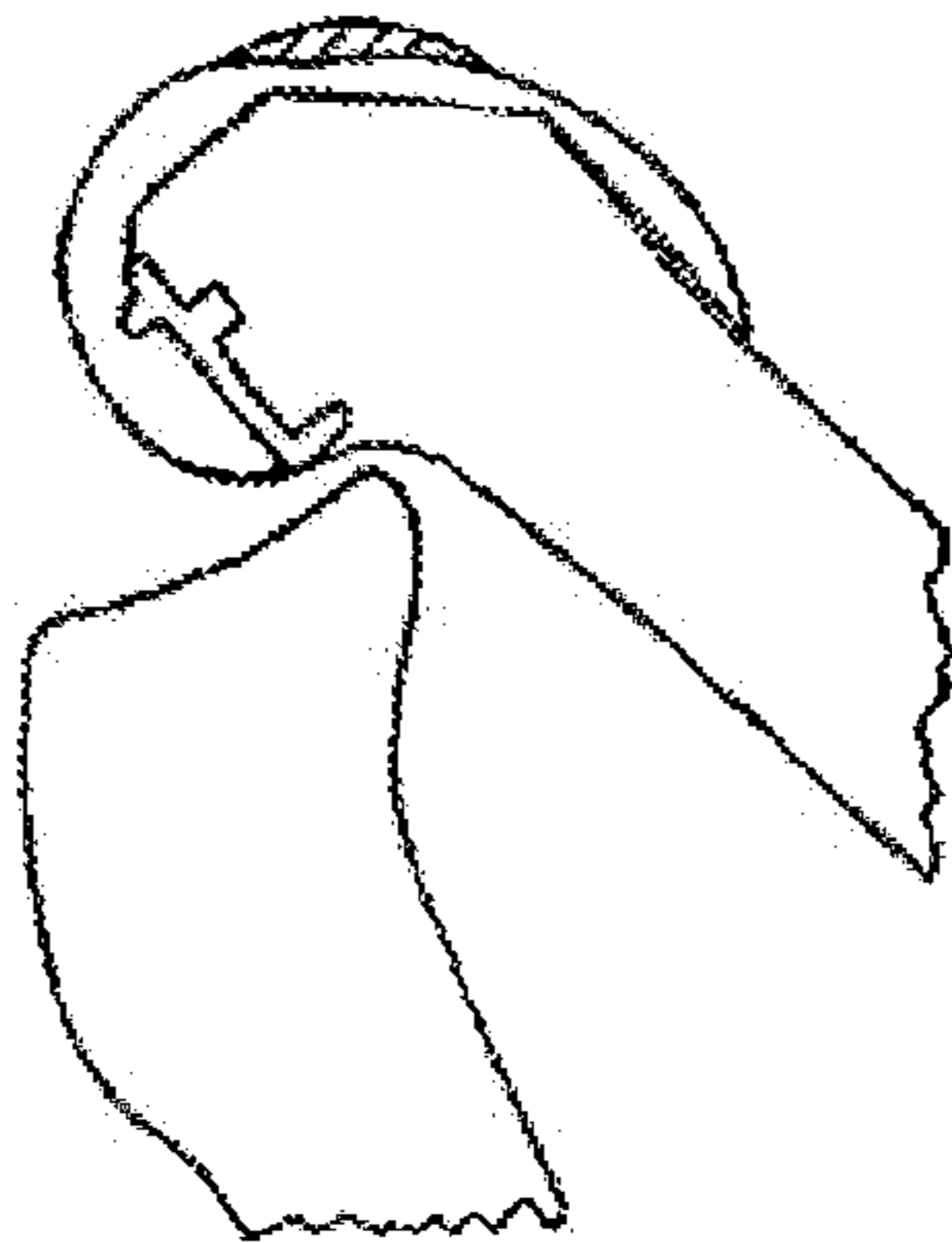

Figure 10G

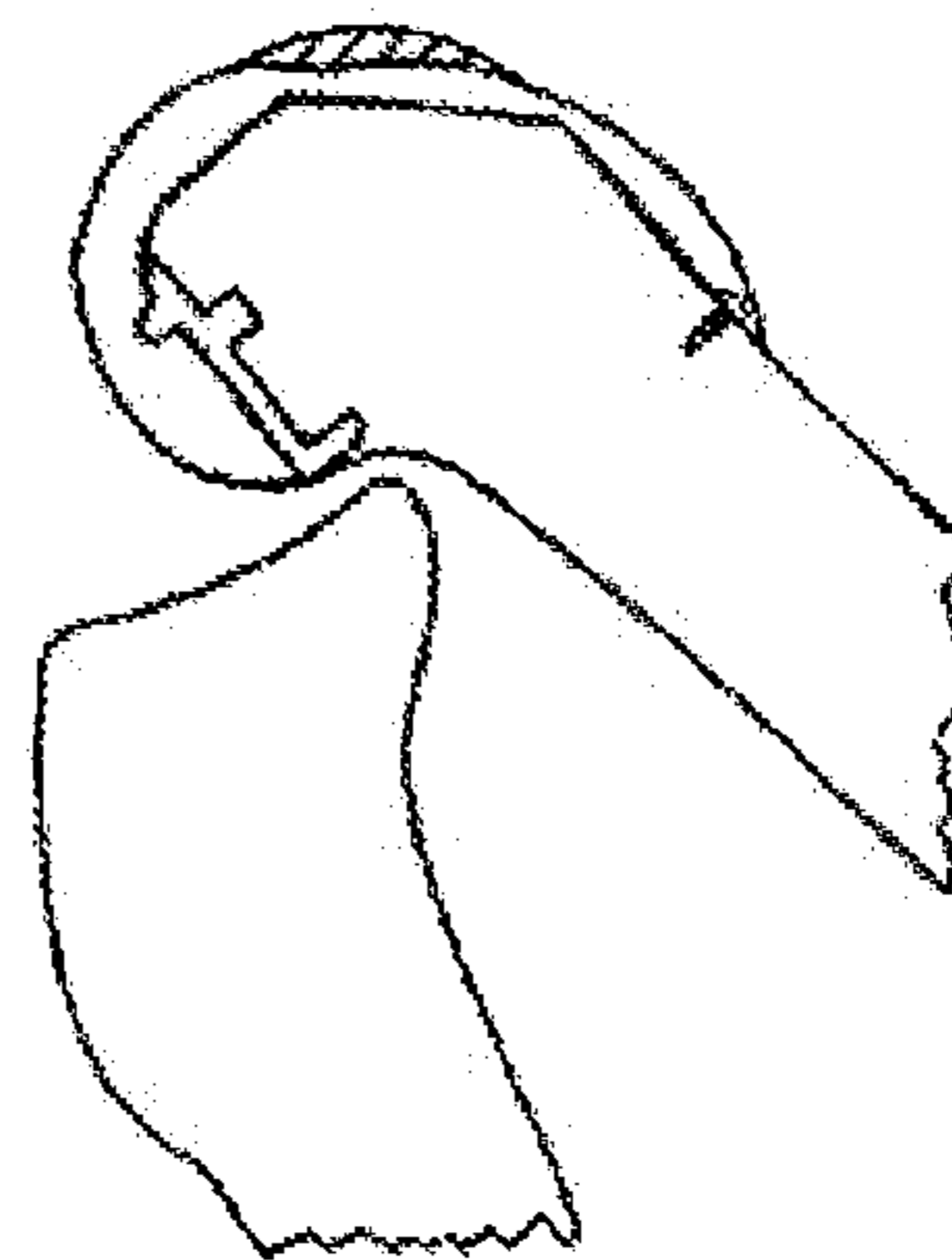

Figure 10H

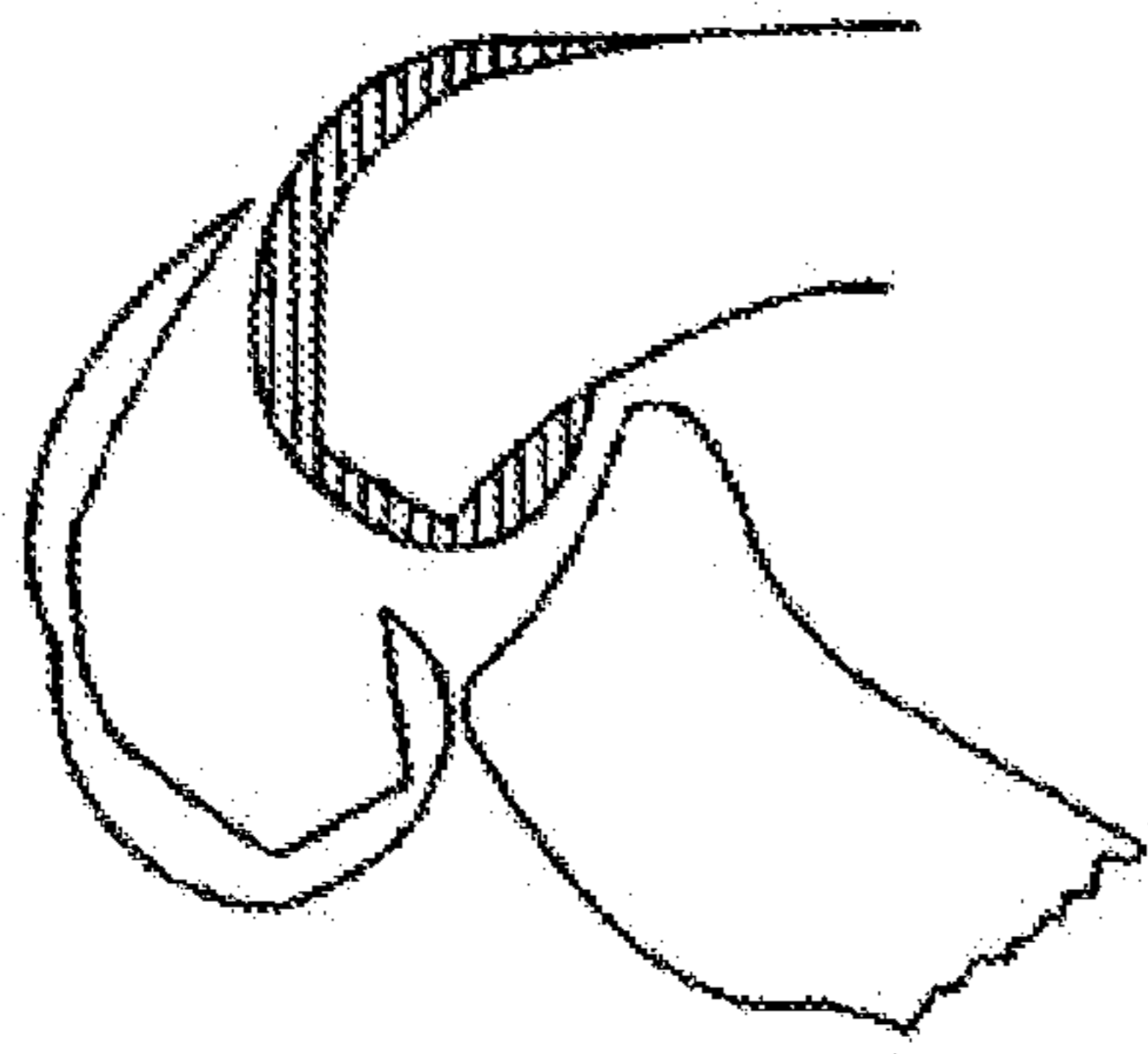

Figure 11A

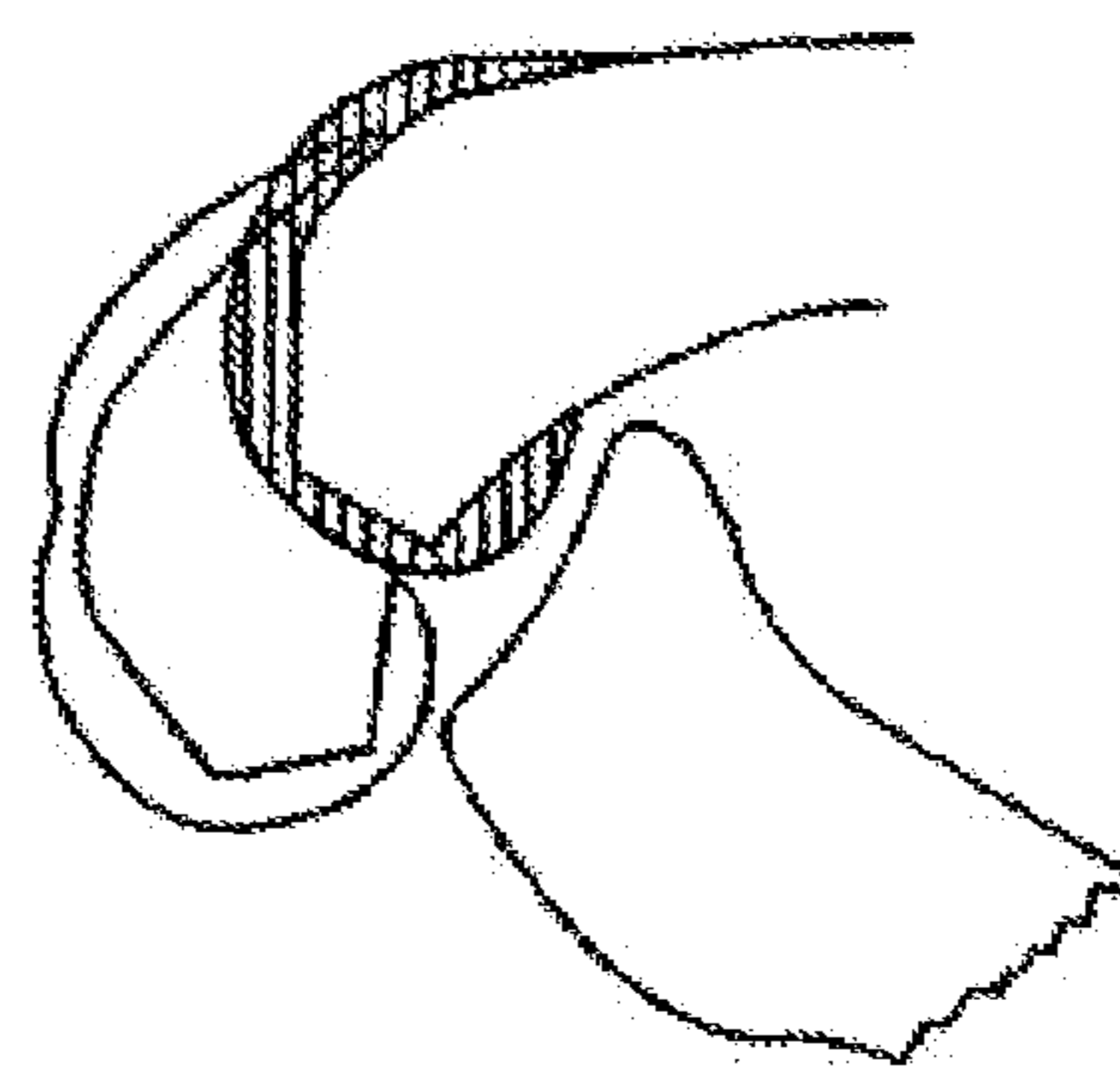

Figure 11B

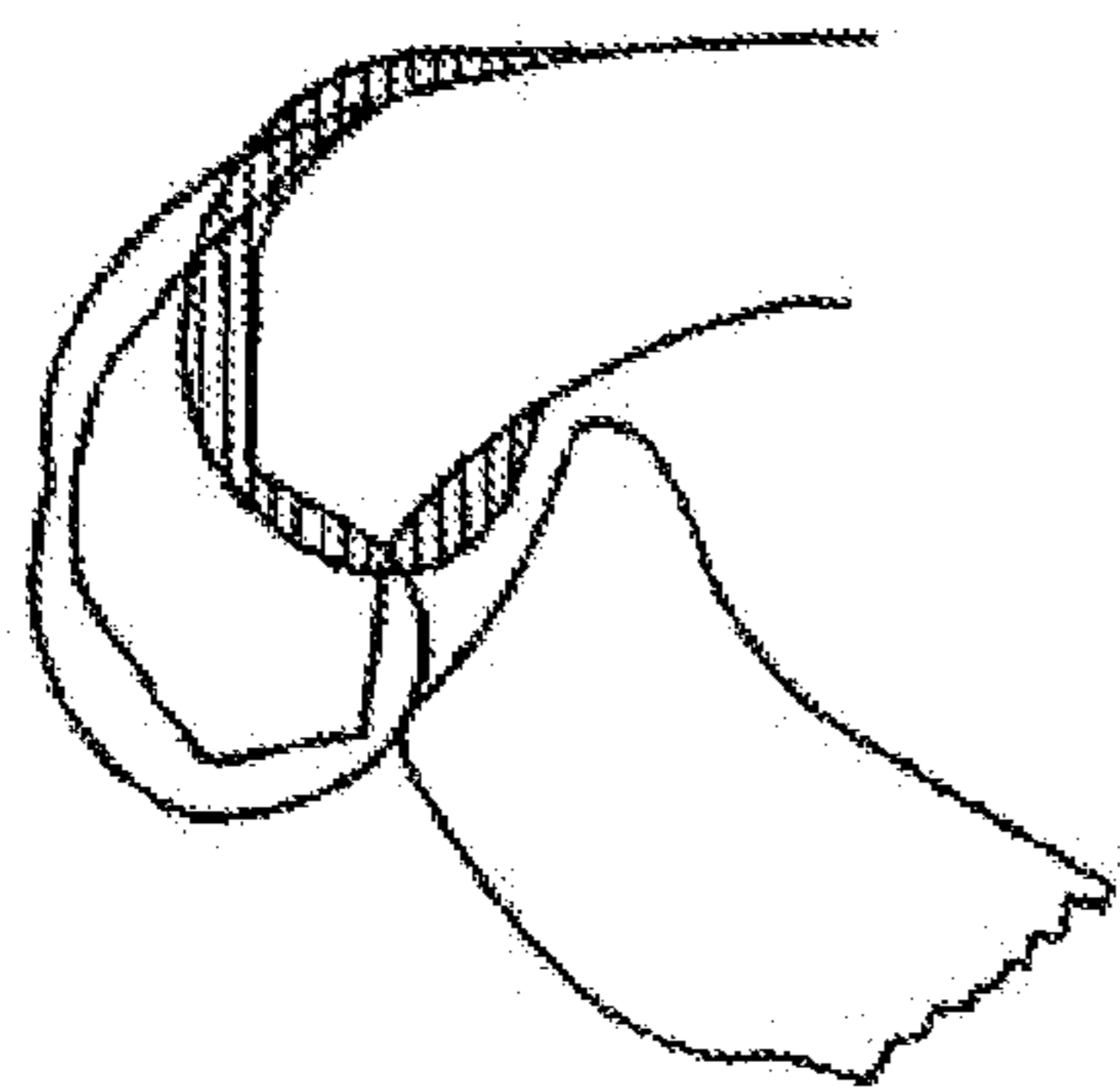

Figure 11C

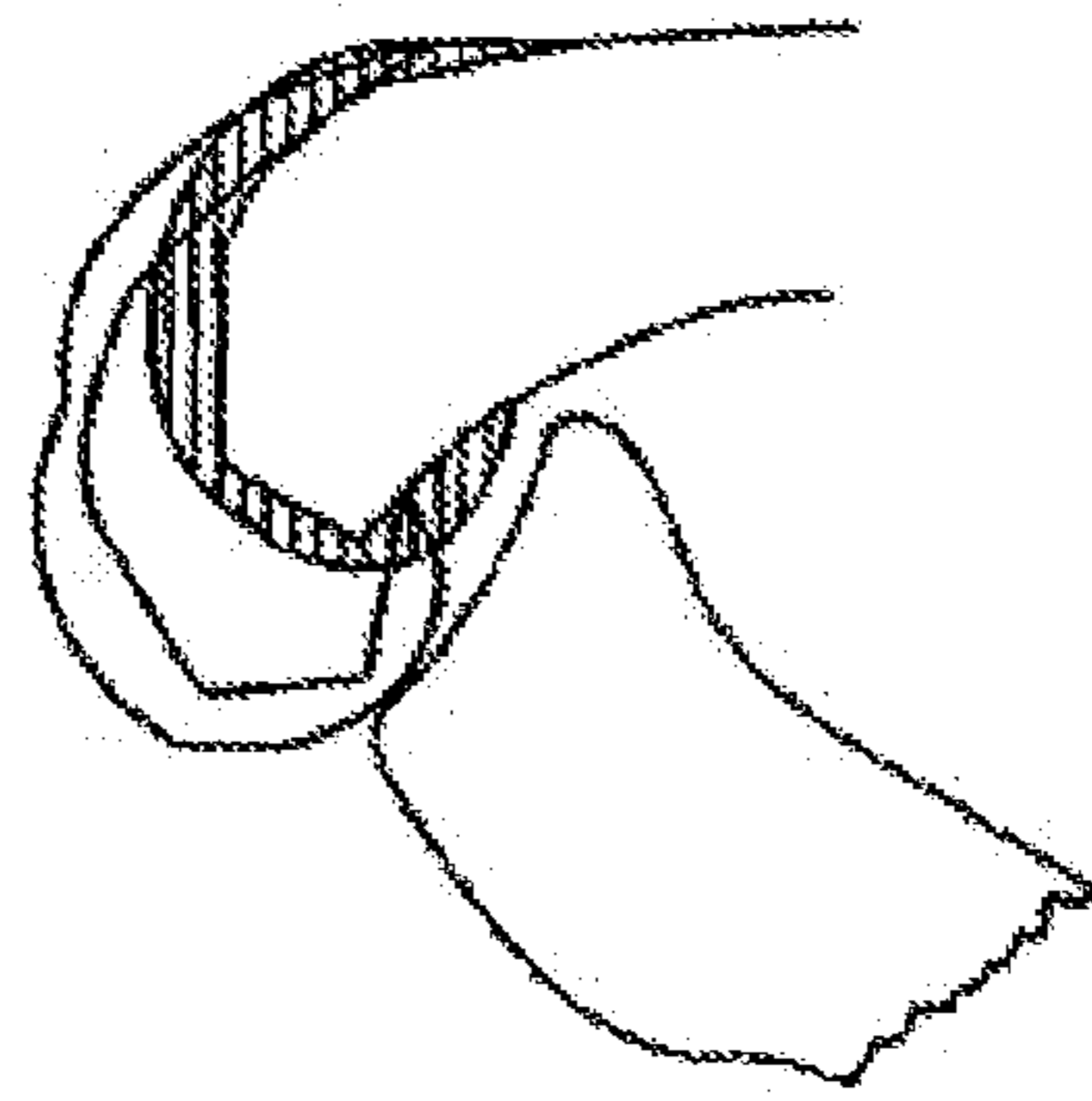

Figure 11D

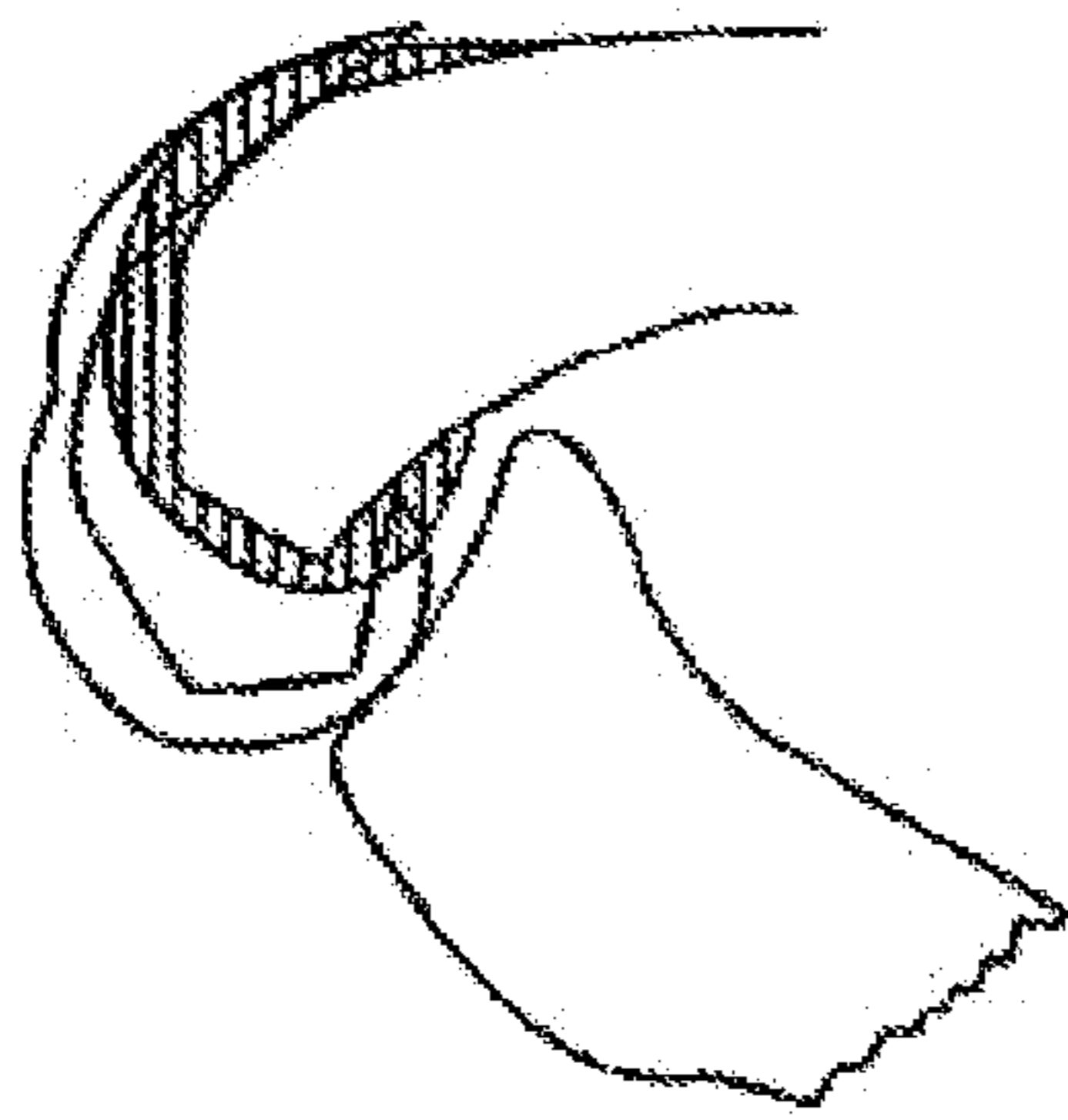

Figure 11E

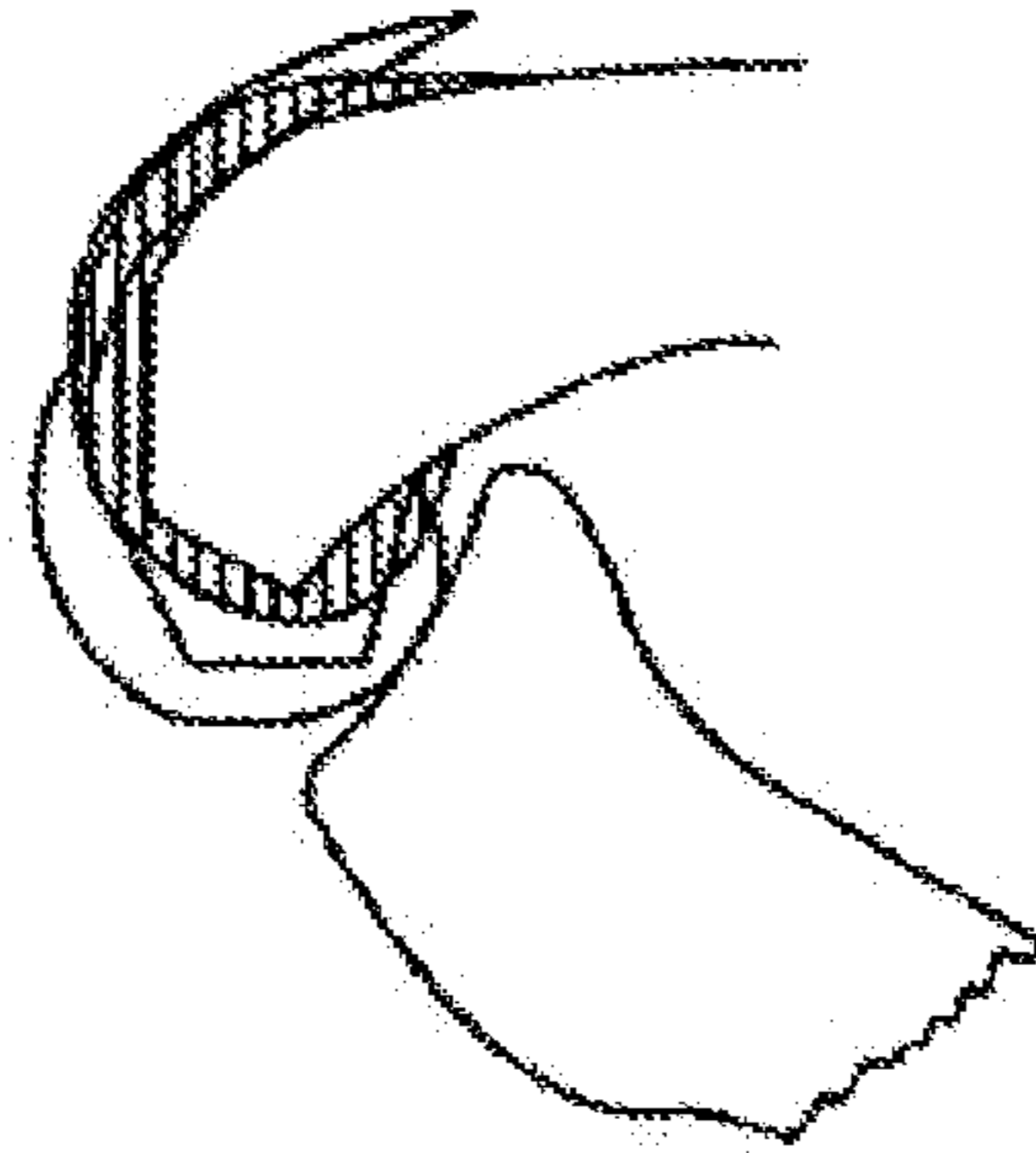

Figure 11F

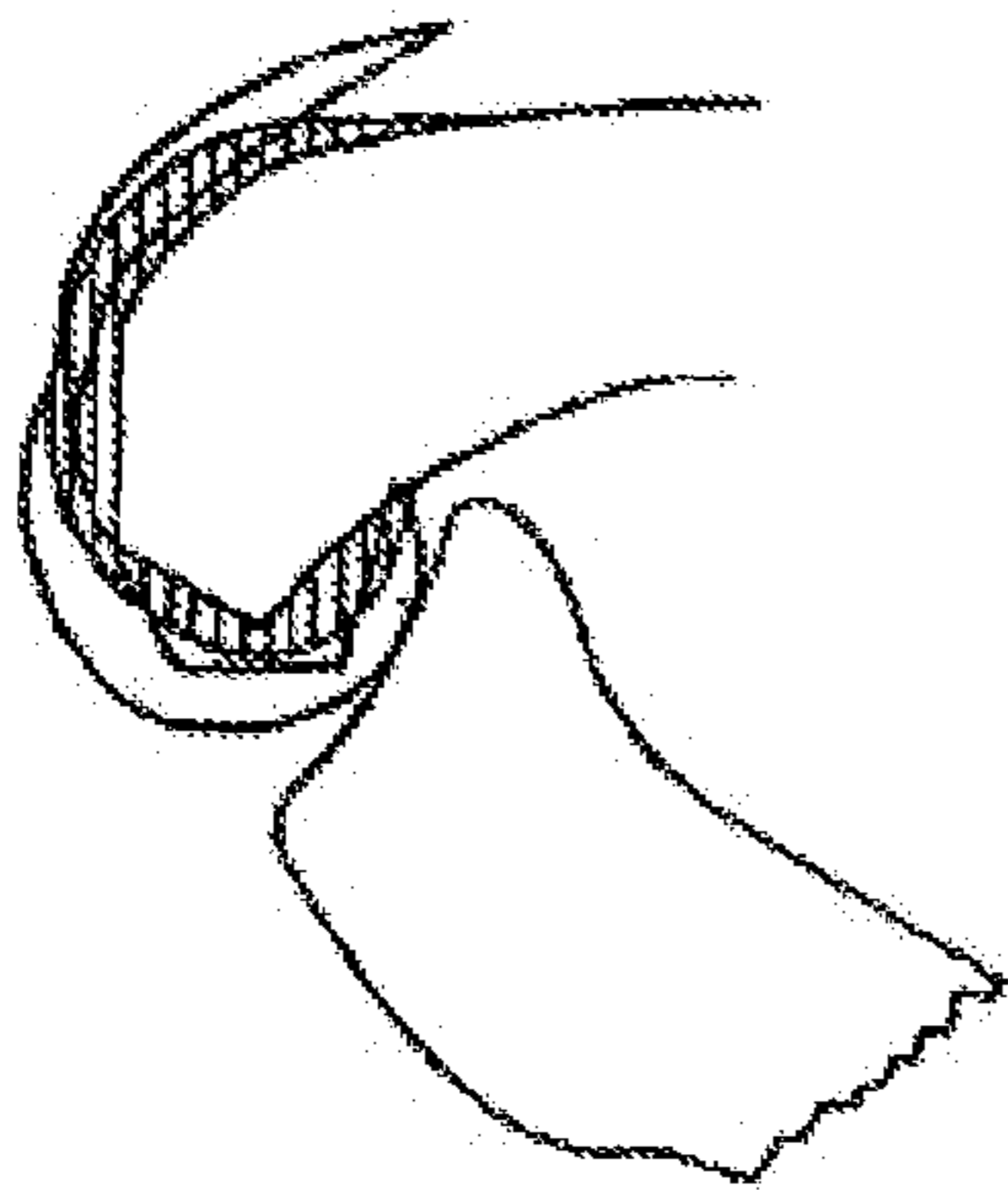

Figure 11G

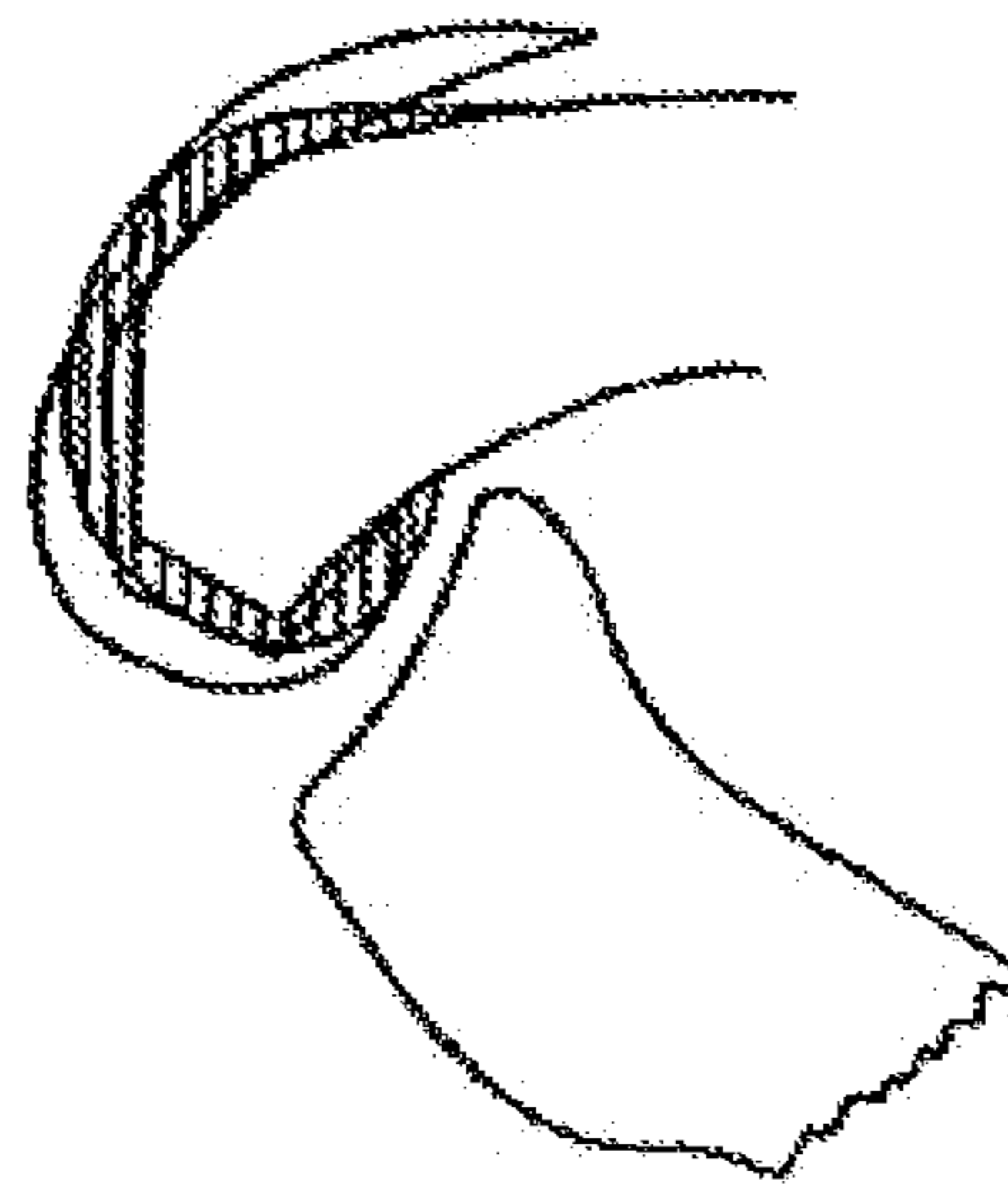

Figure 11H

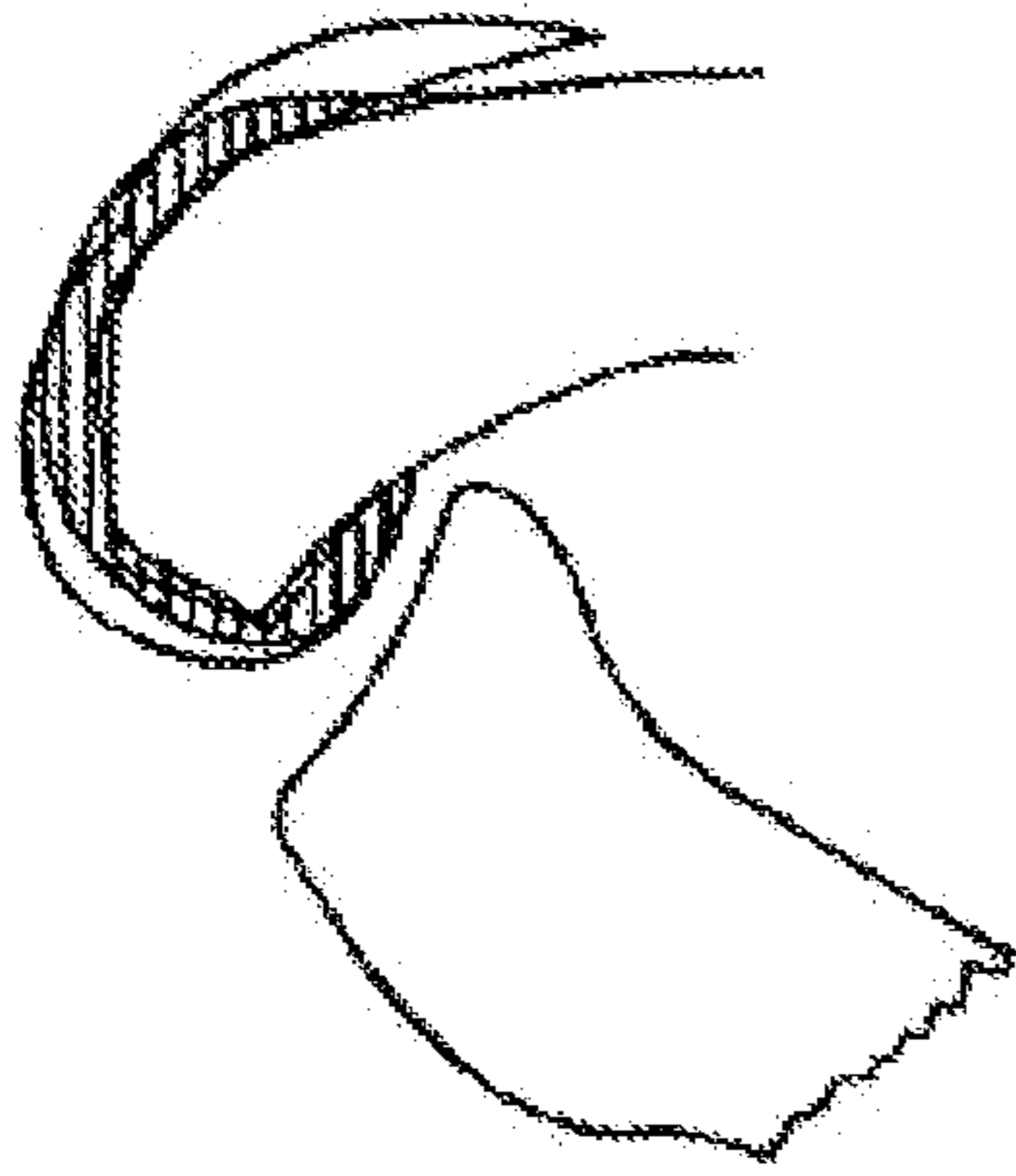

Figure 11I

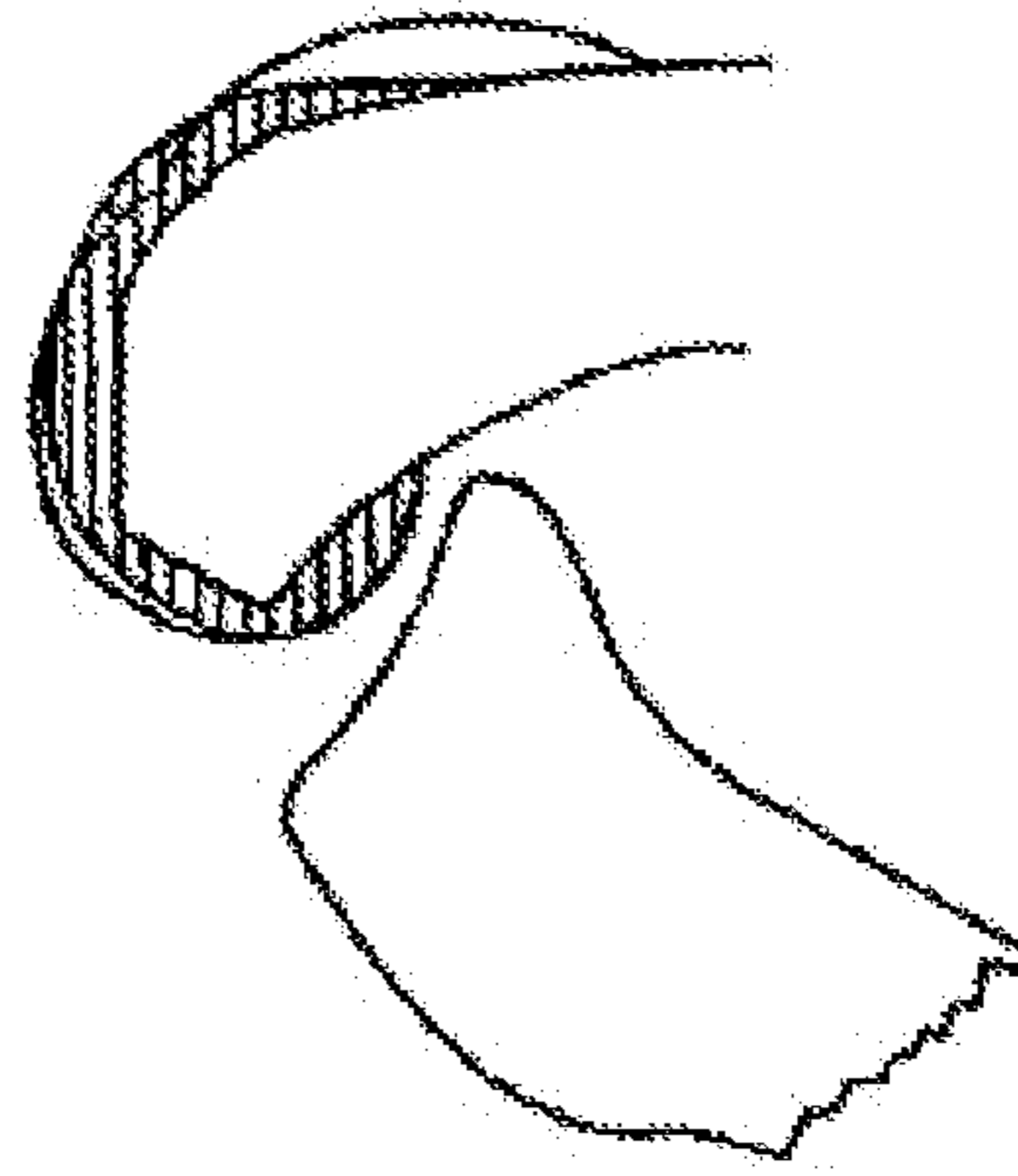

Figure 11J

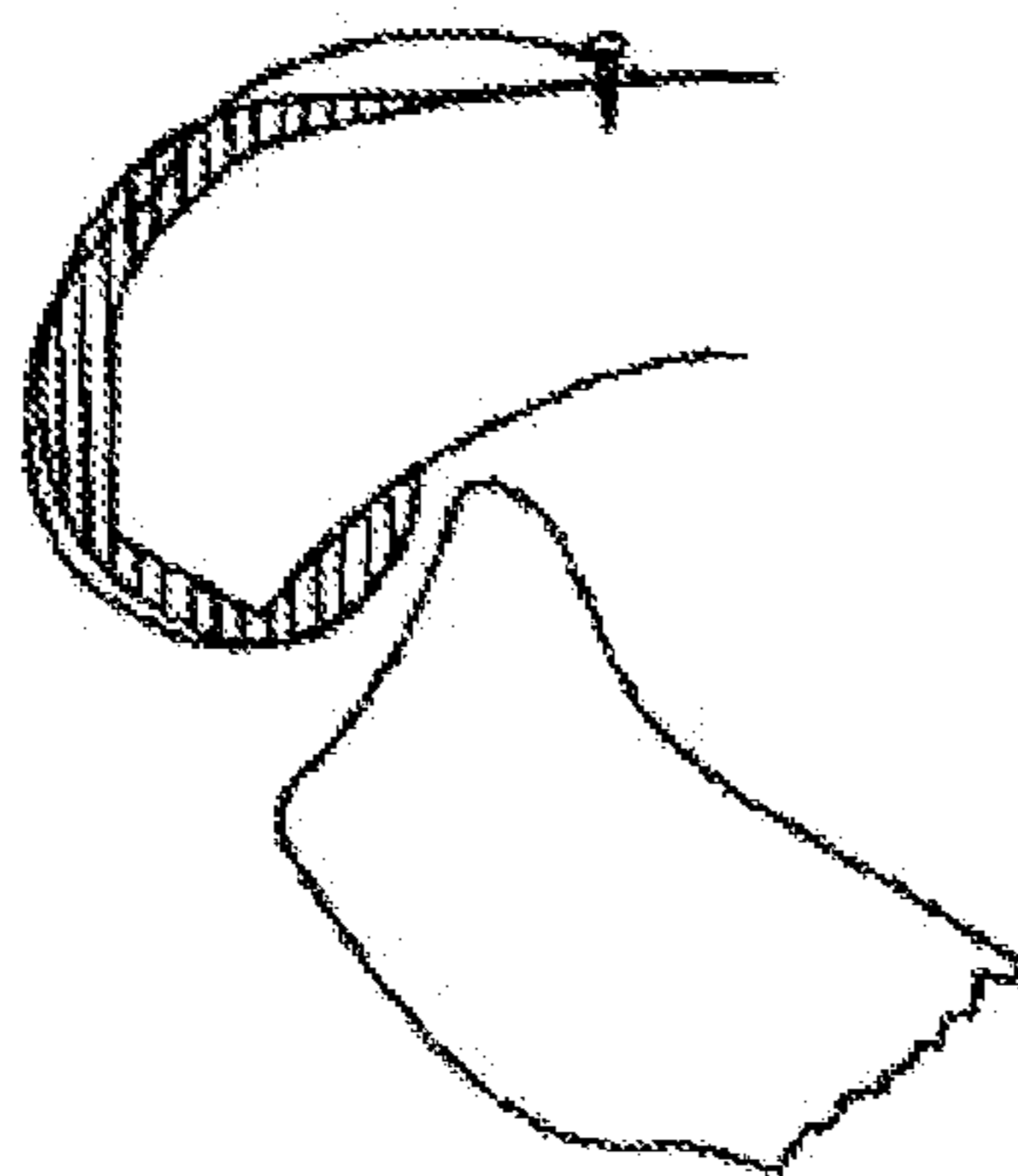

Figure 11K

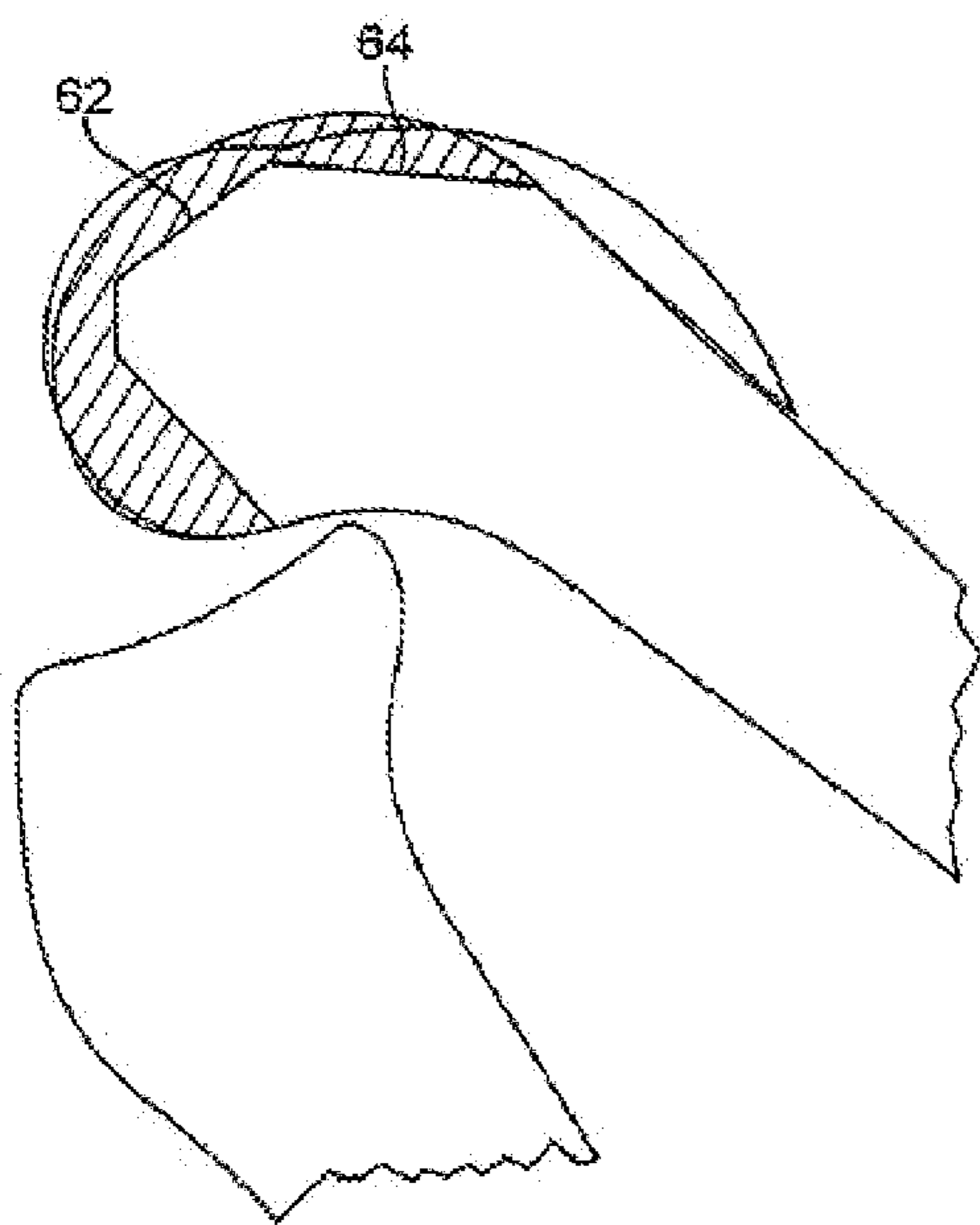

Figure 12A

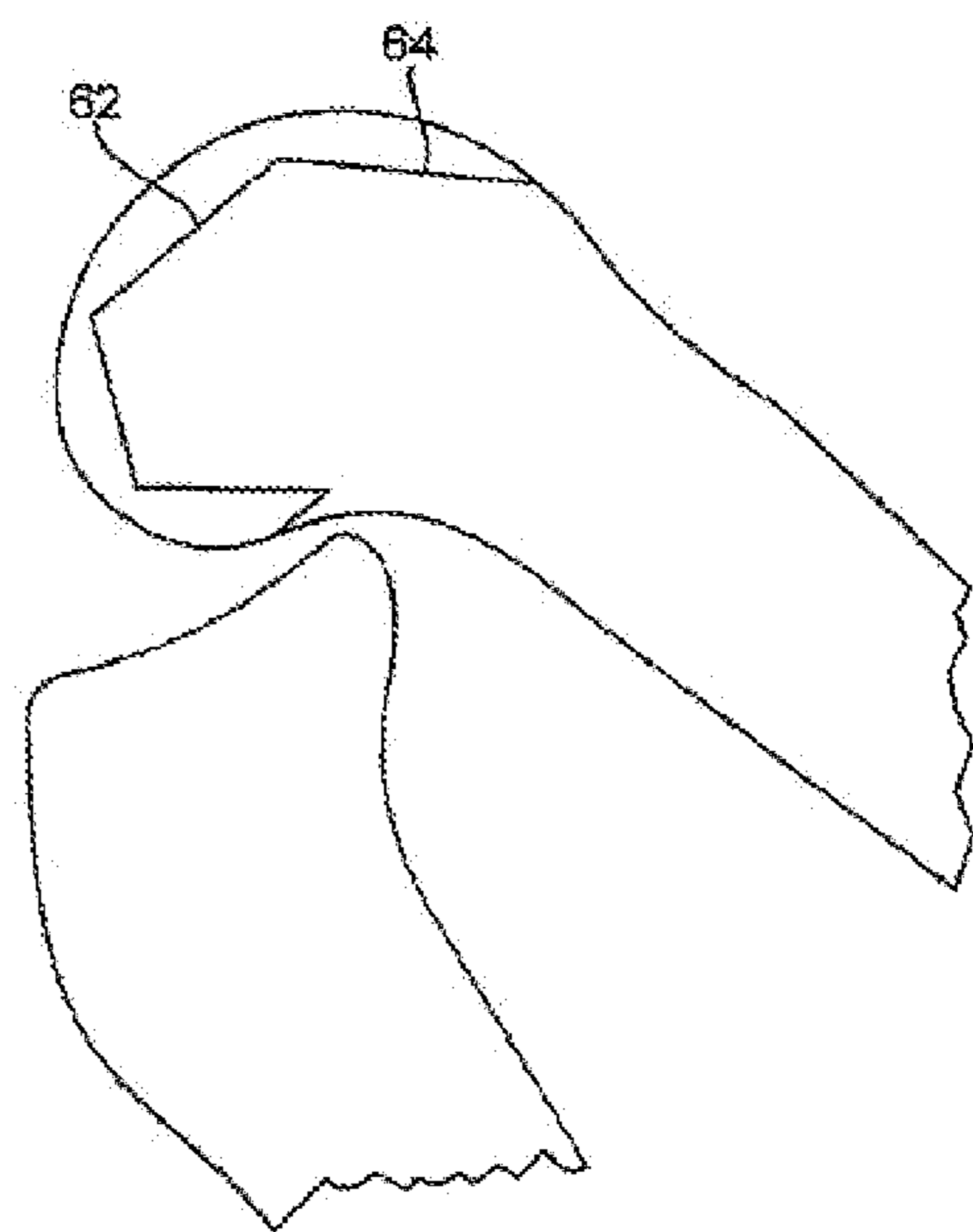

Figure 12B

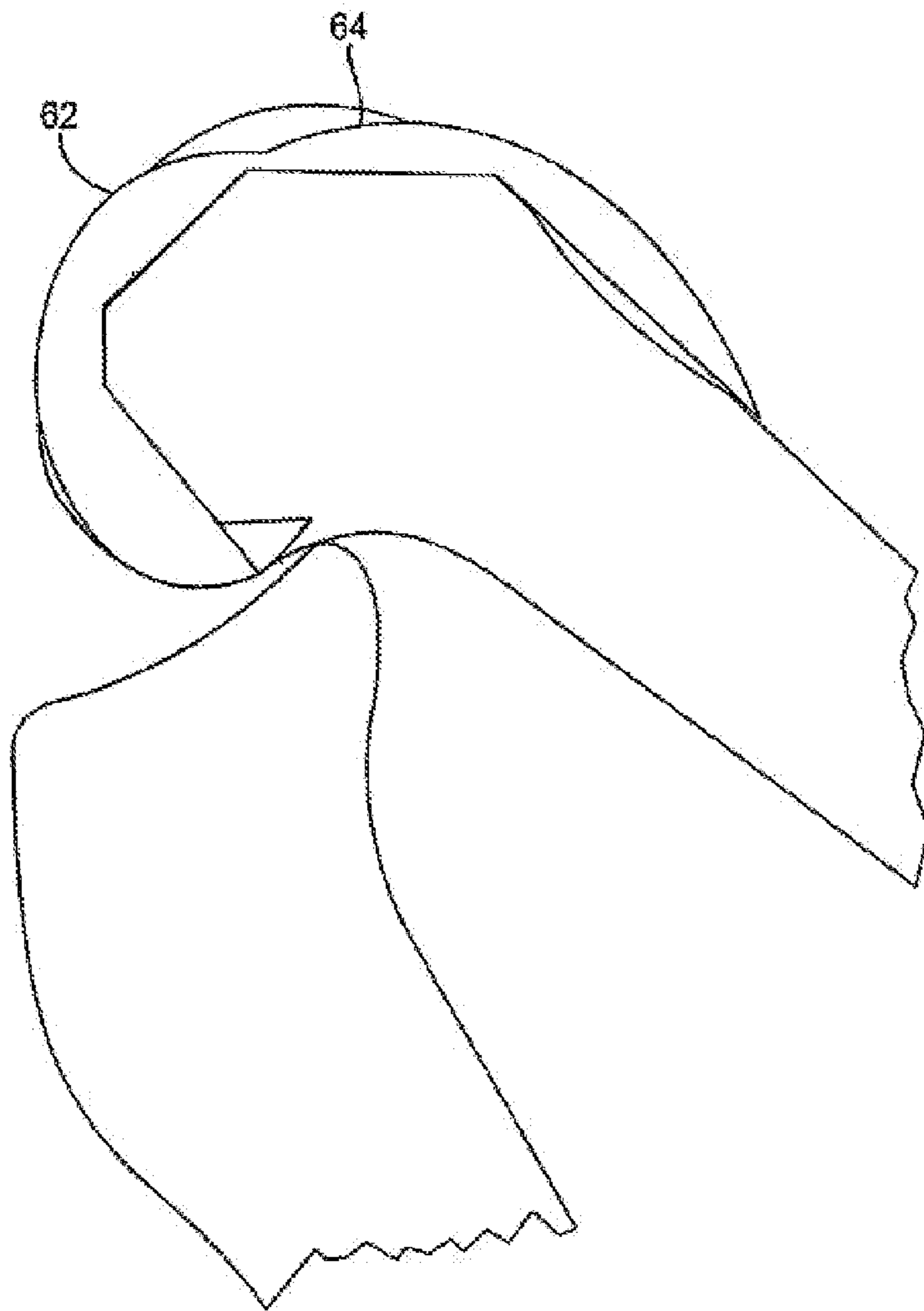

Figure 13

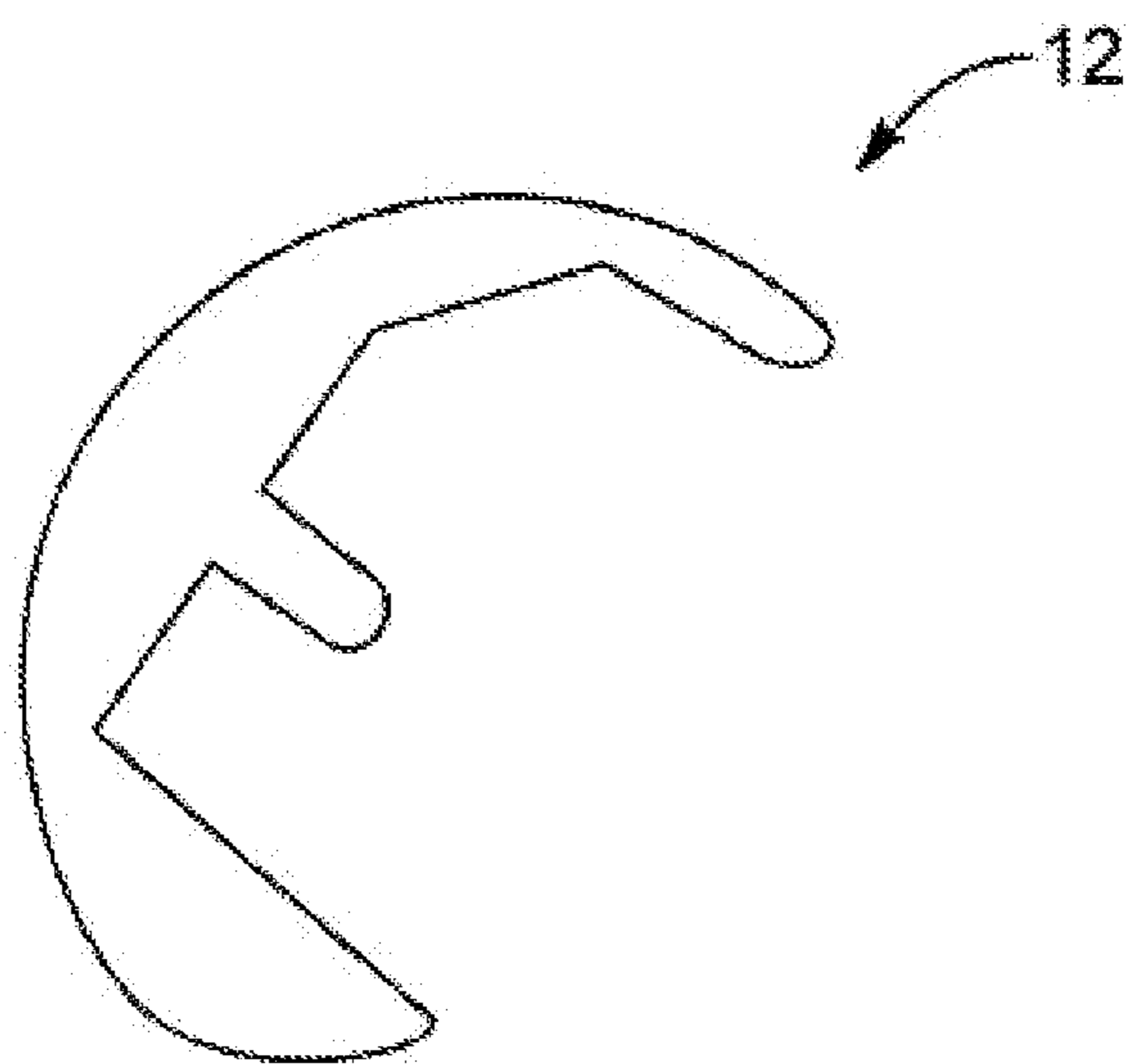

Figure 14

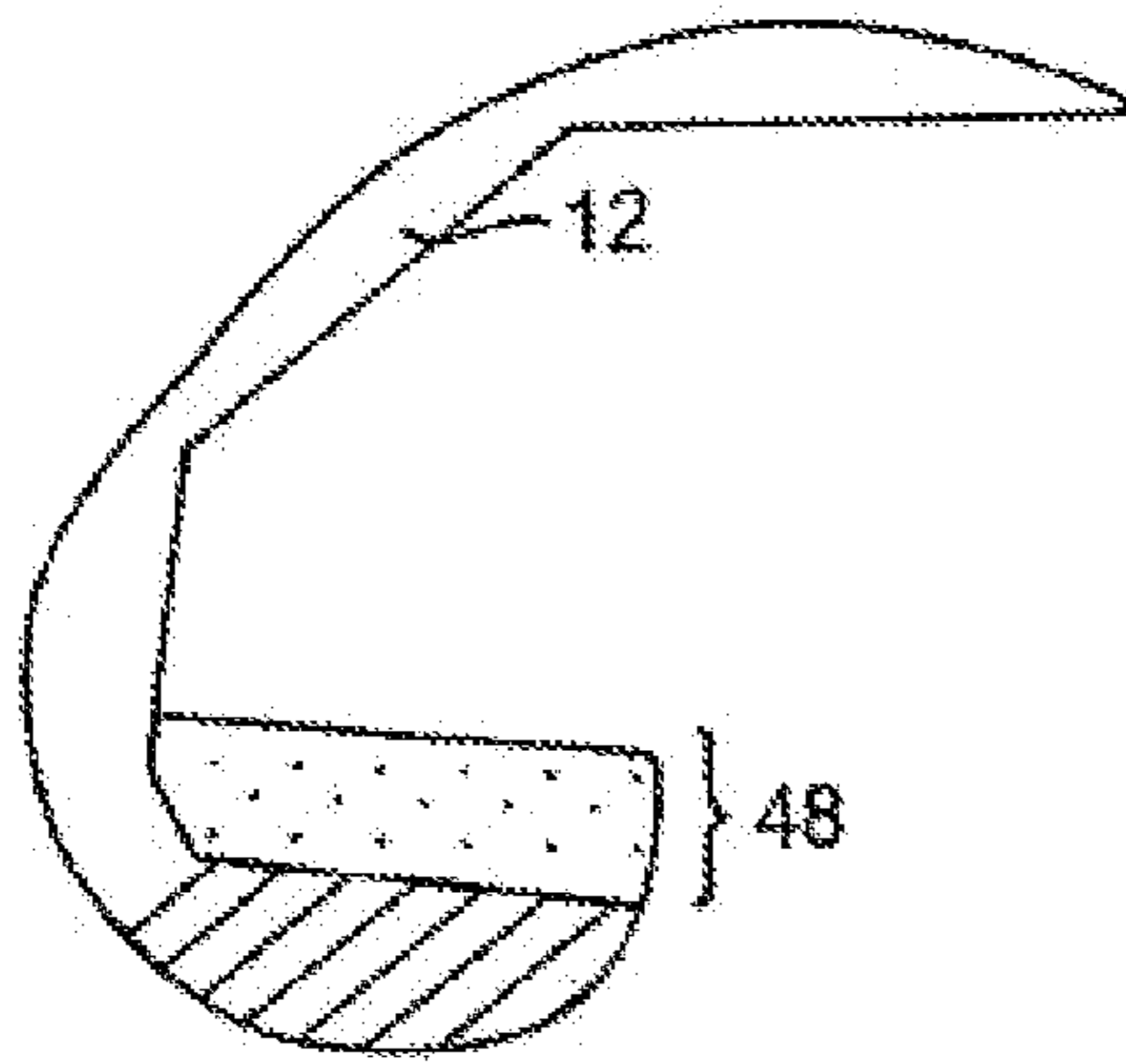

Figure 15A

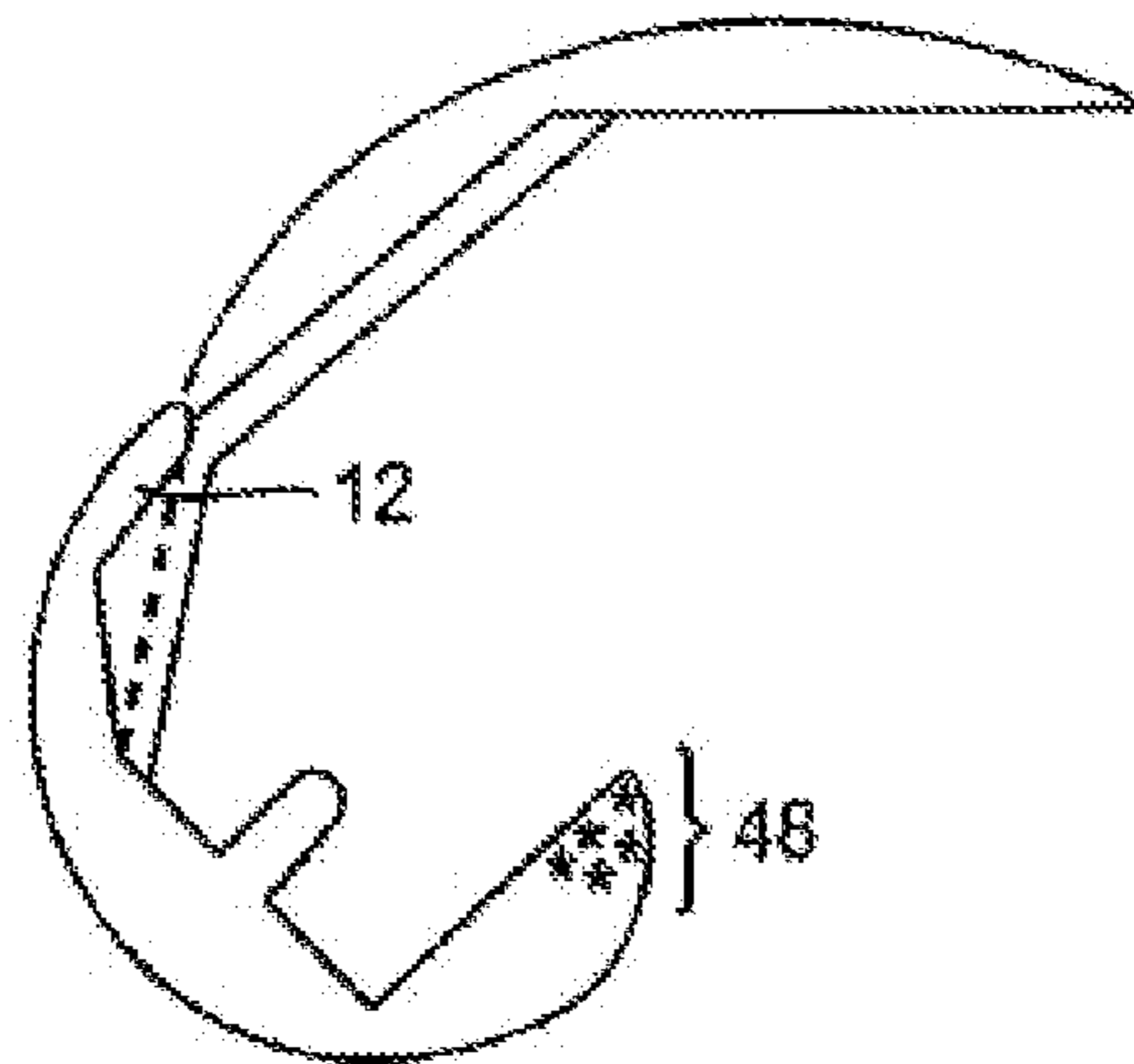

Figure 15B

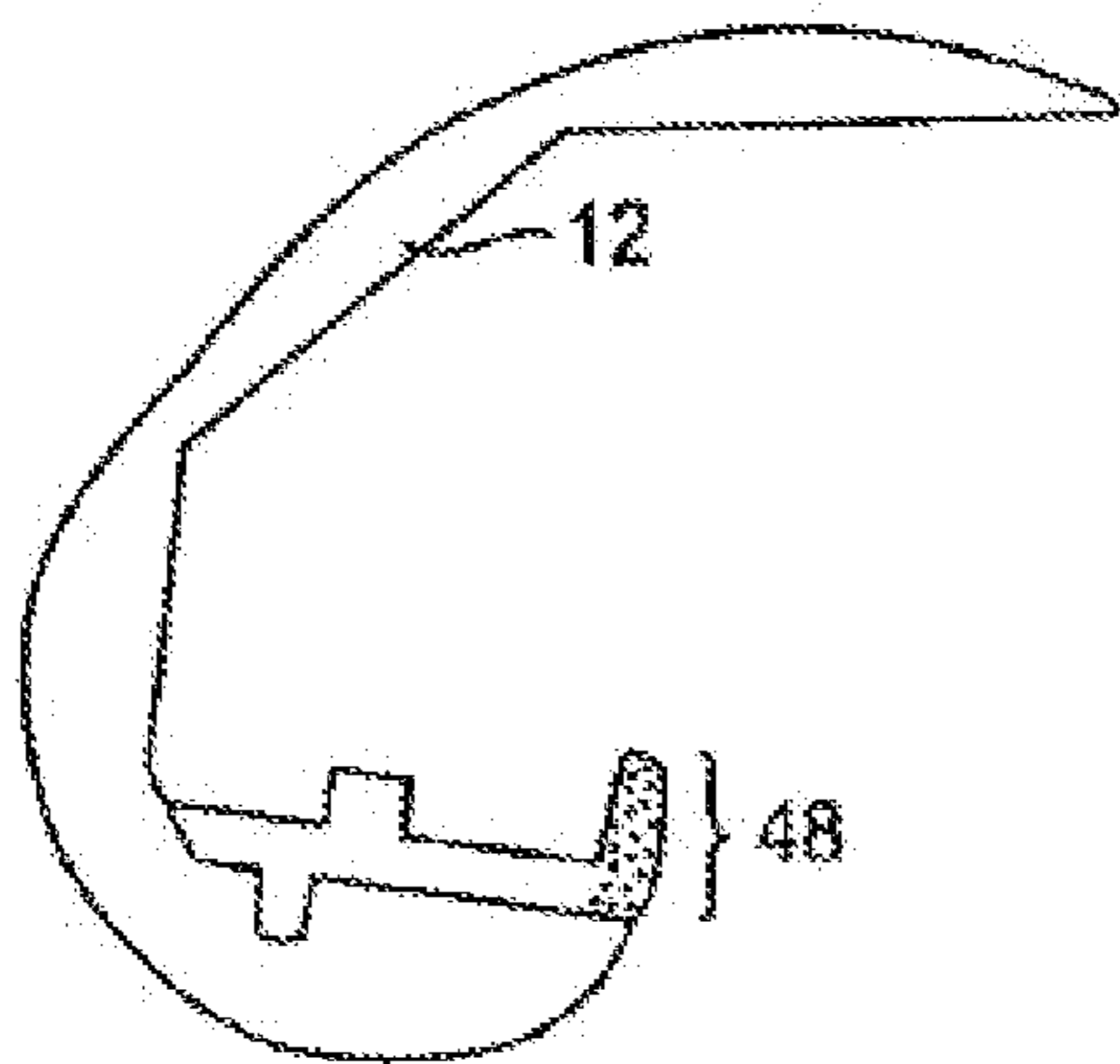

Figure 15C

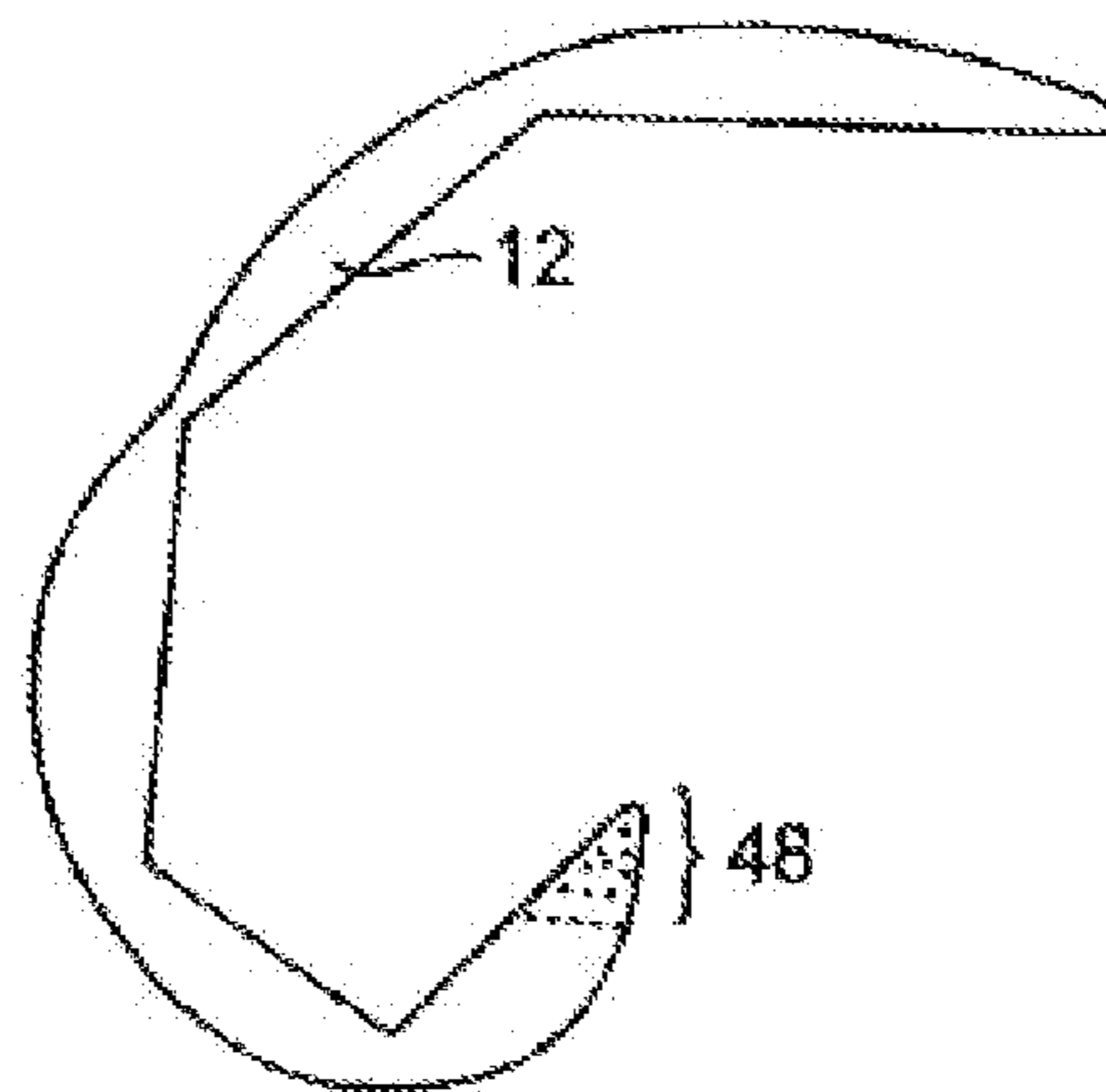

Figure 15D

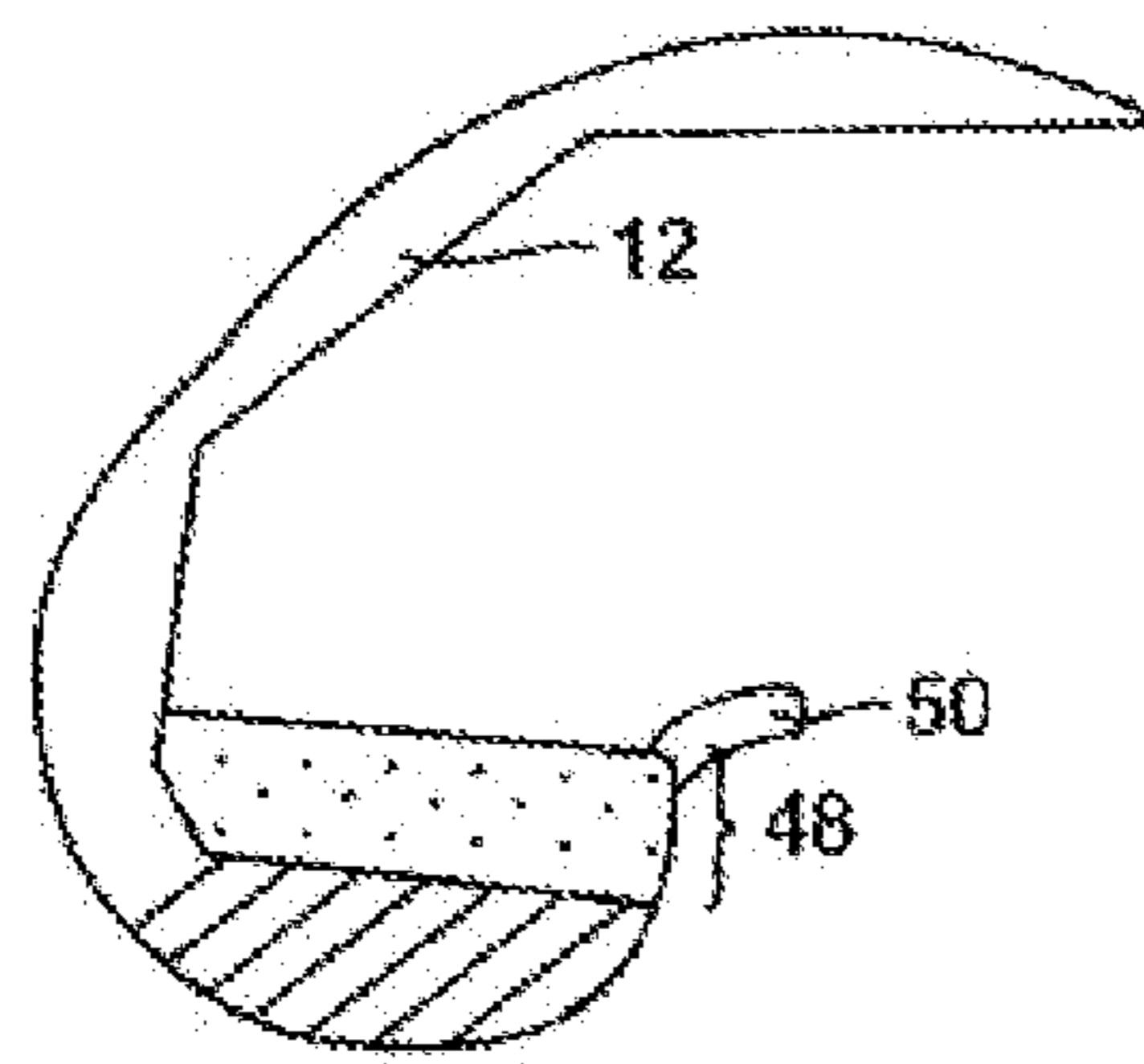

Figure 16A

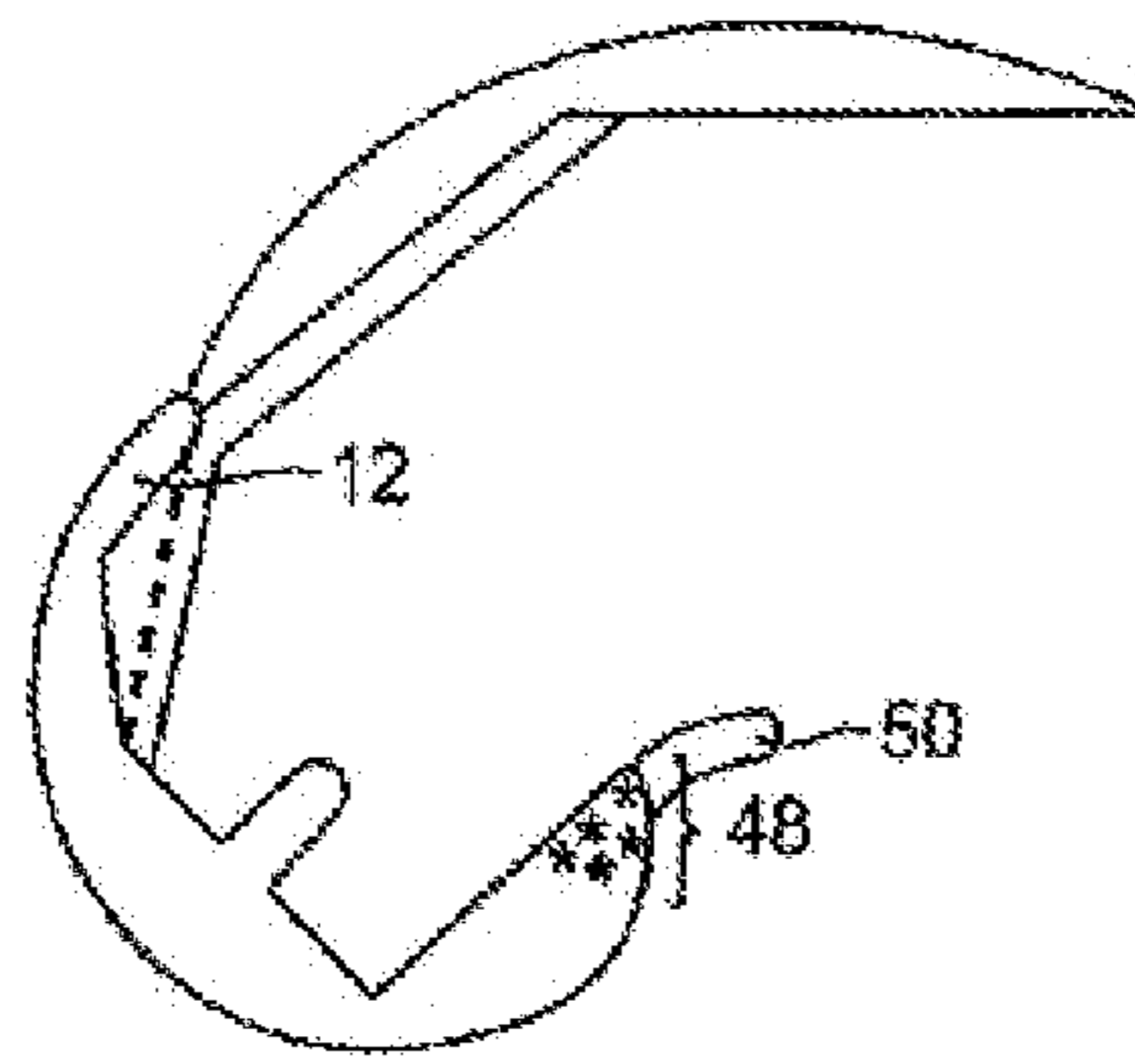

Figure 16B

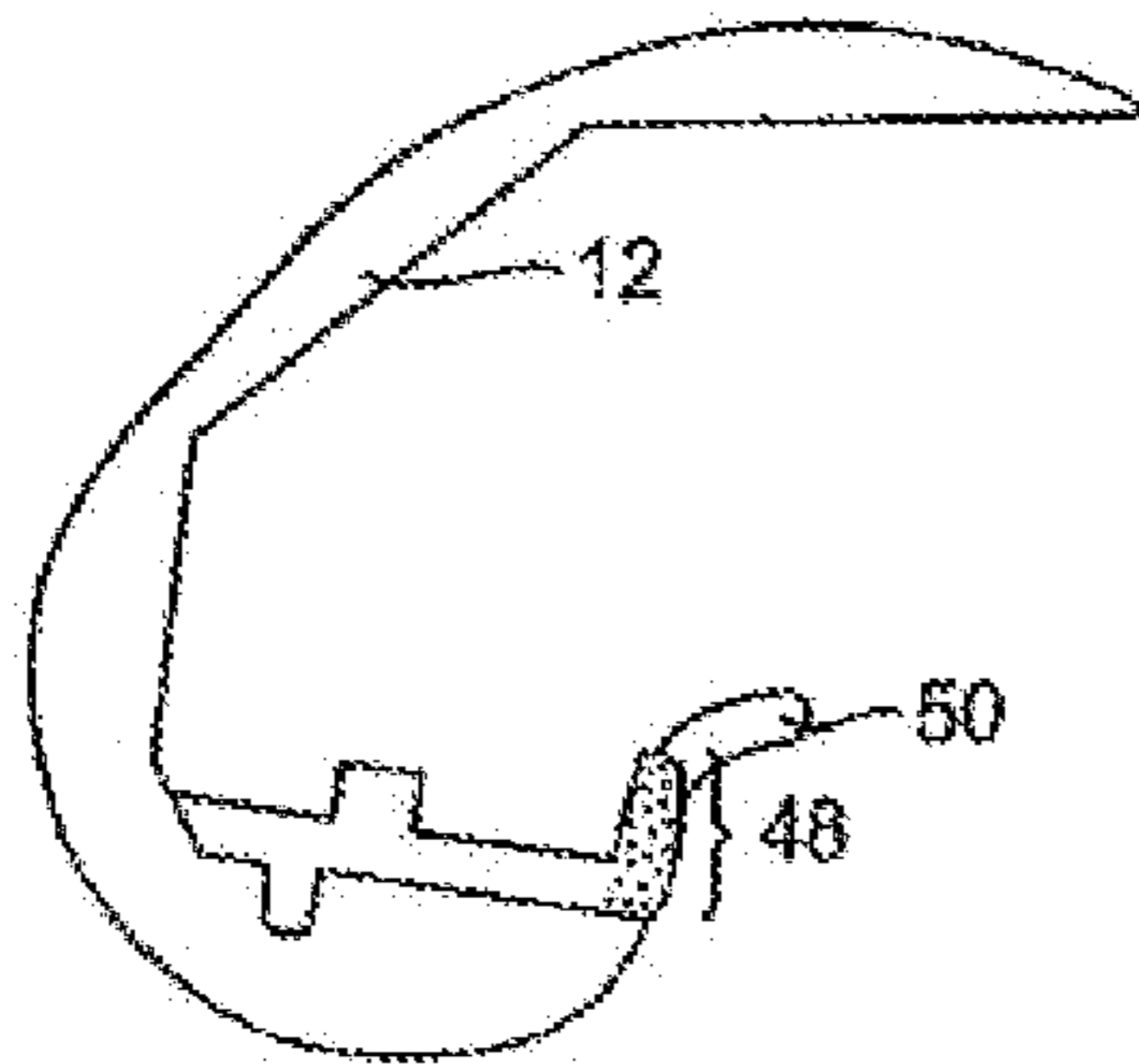

Figure 16C

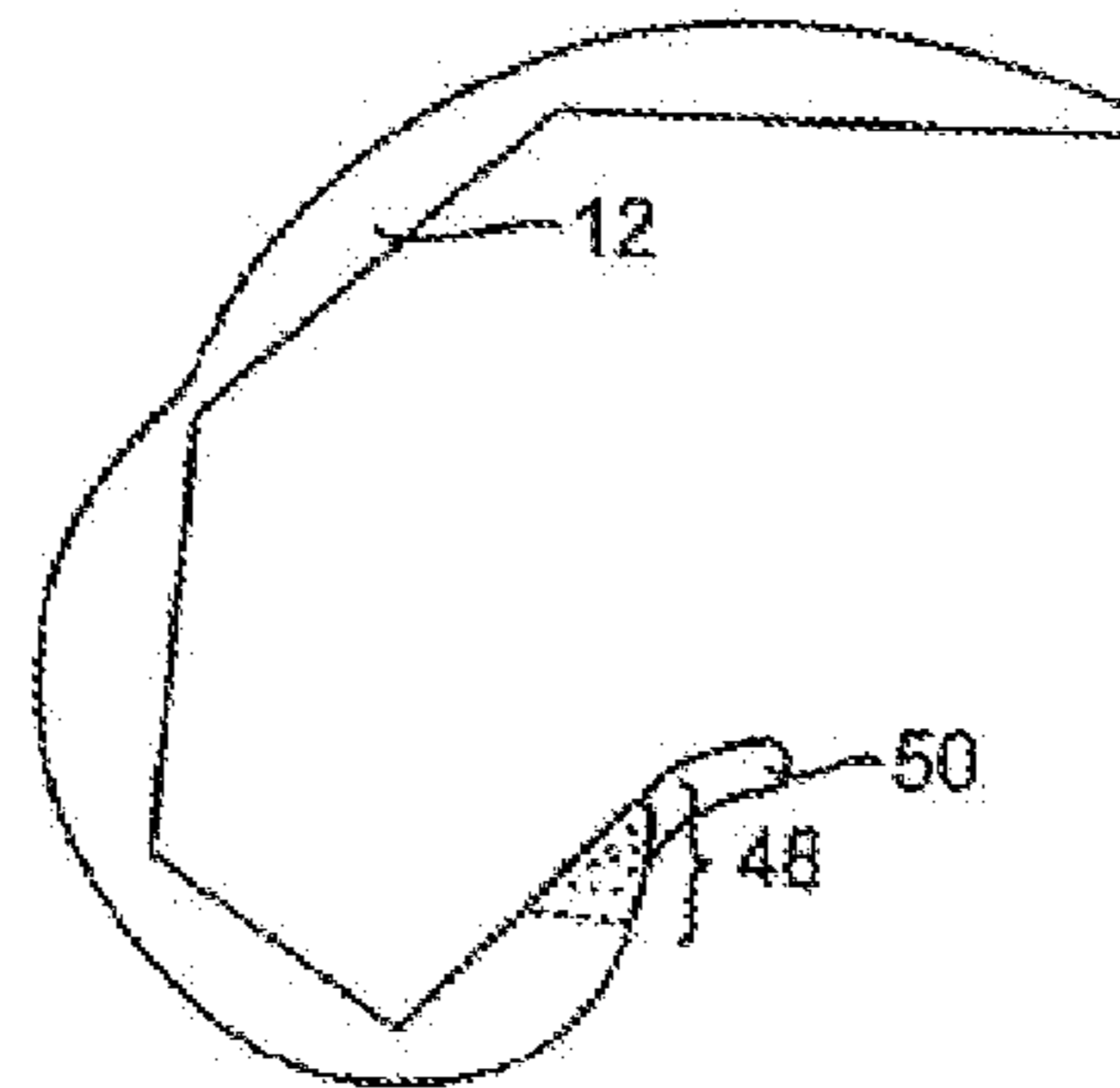

Figure 16D

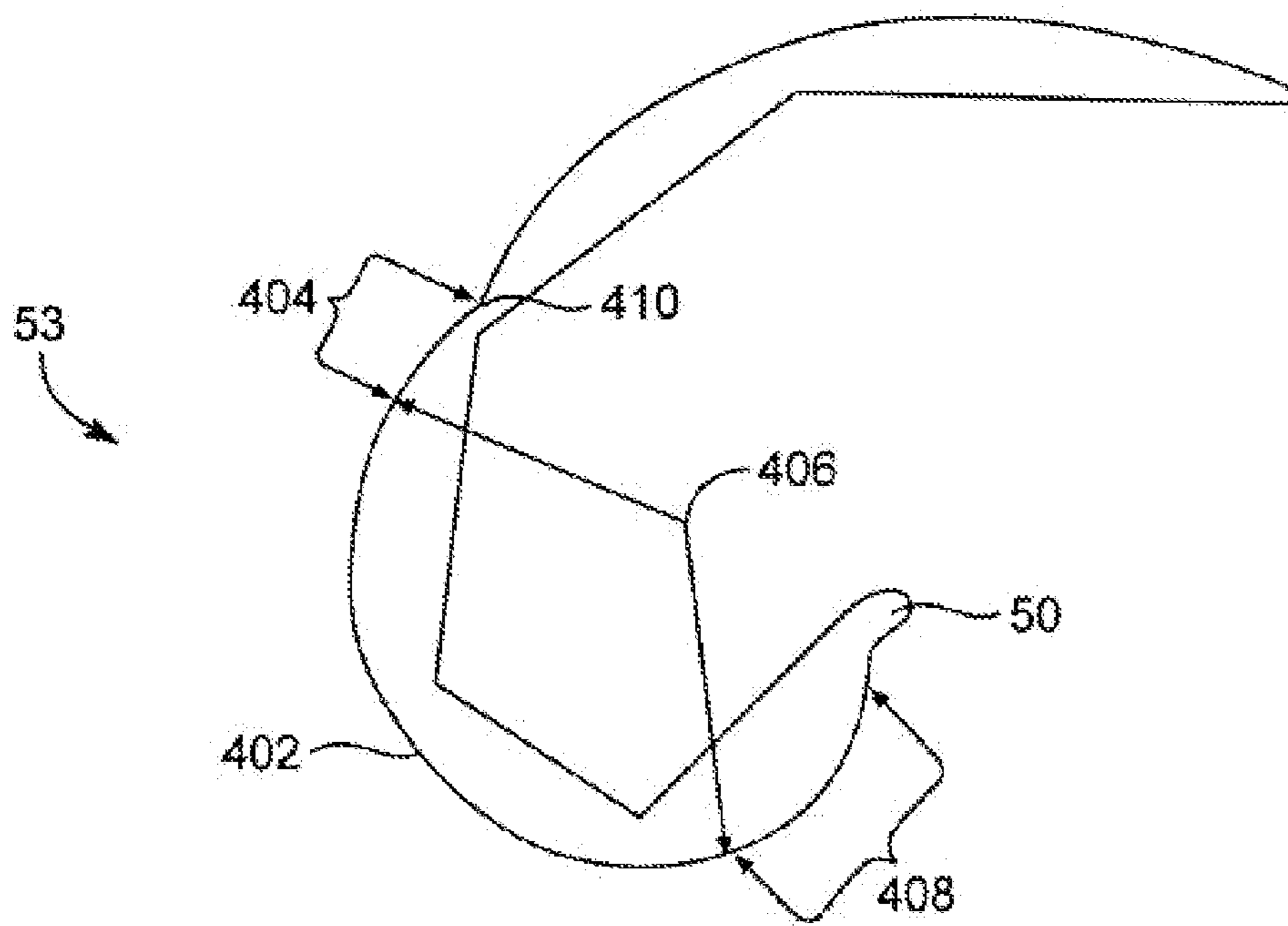

Figure 16E

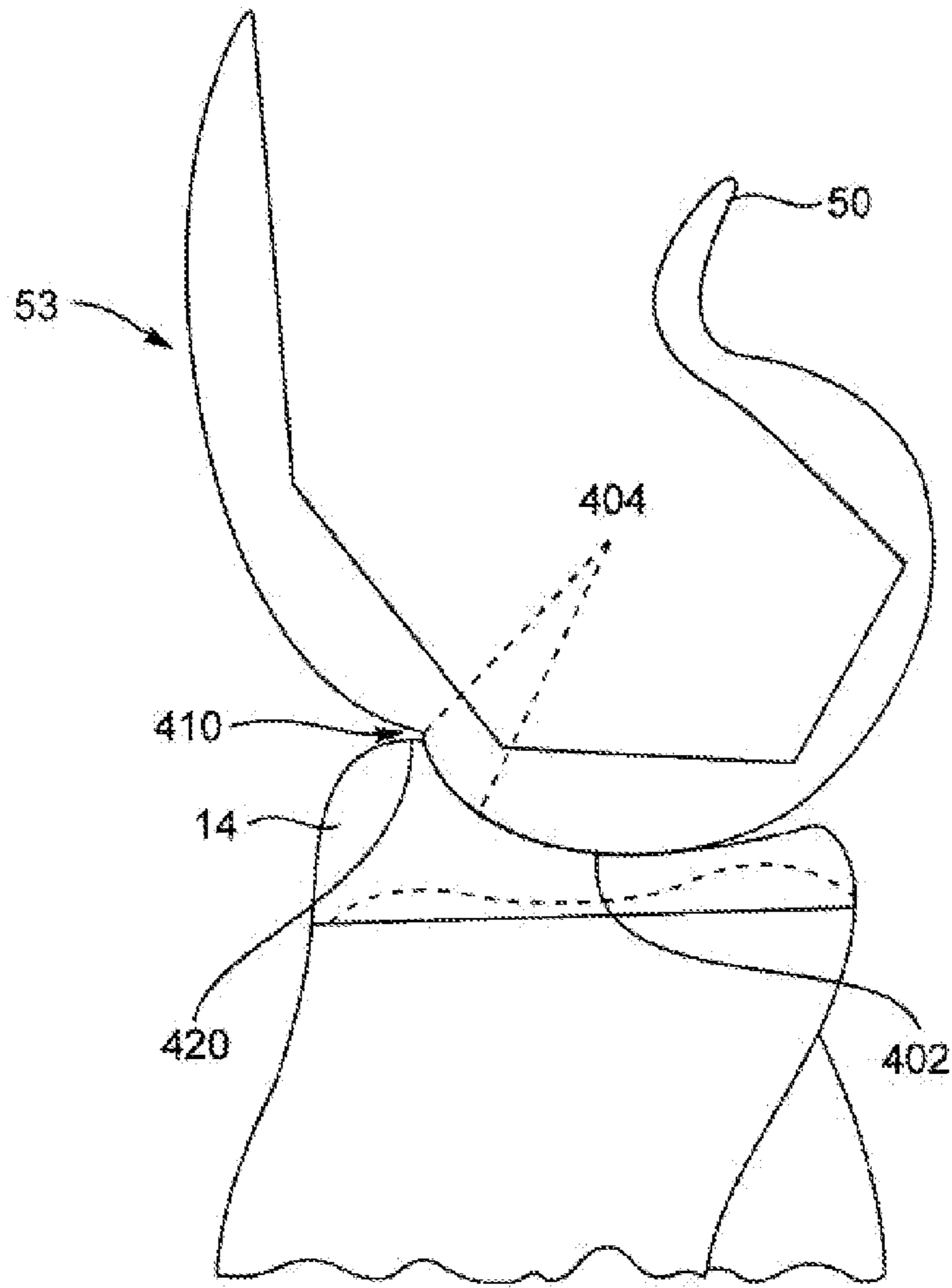

Figure 16F

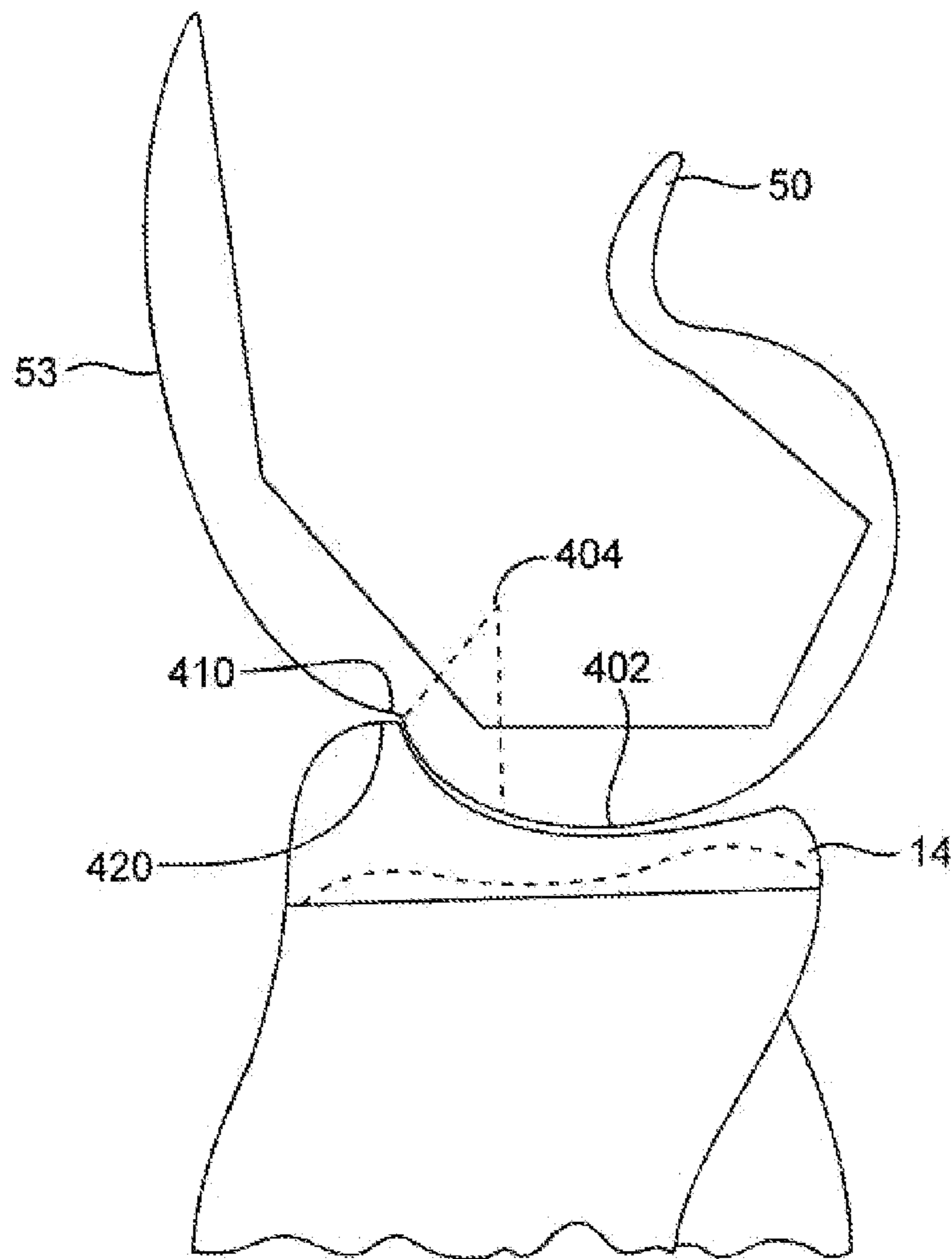

Figure 16G

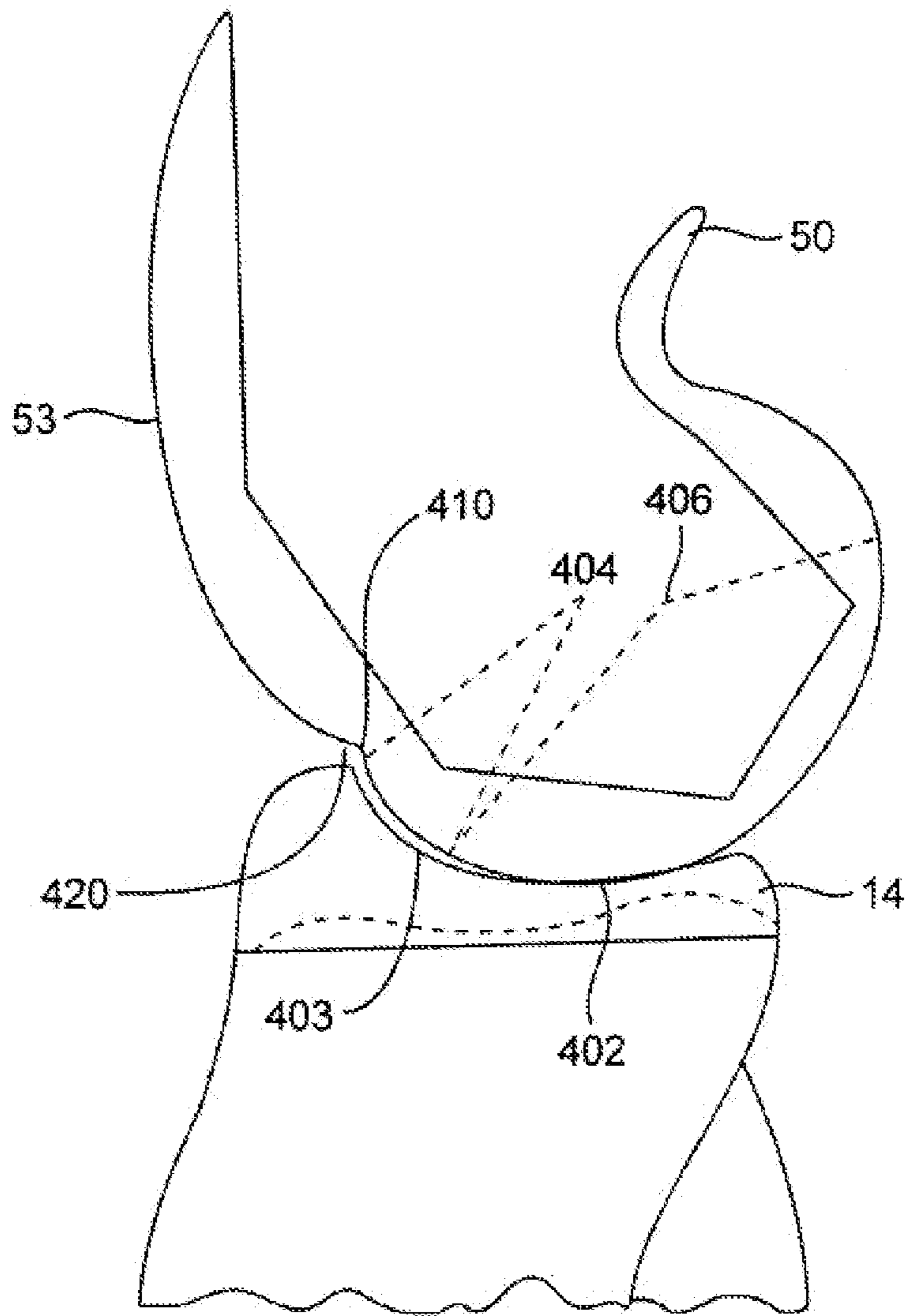

Figure 16H

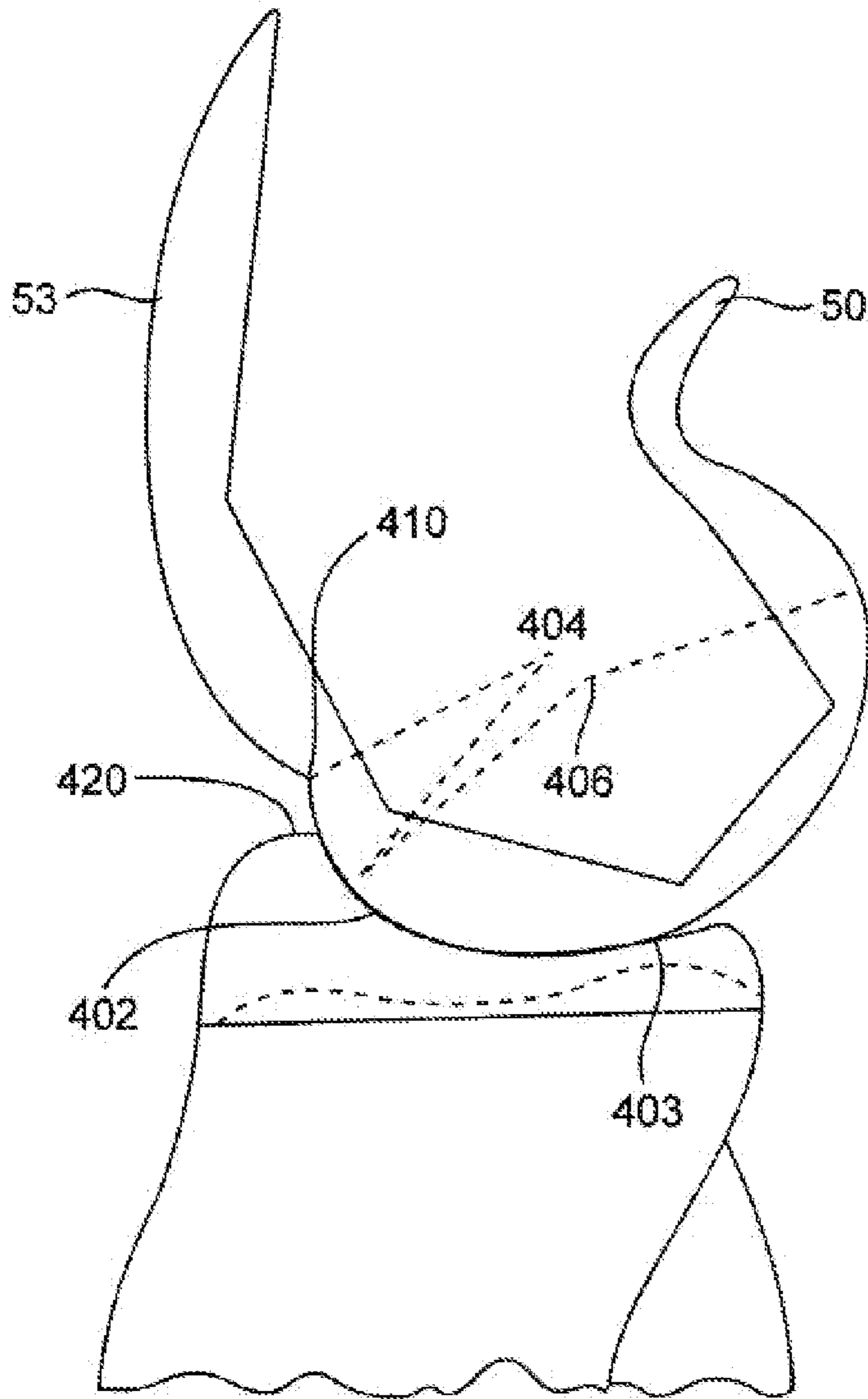

Figure 16l

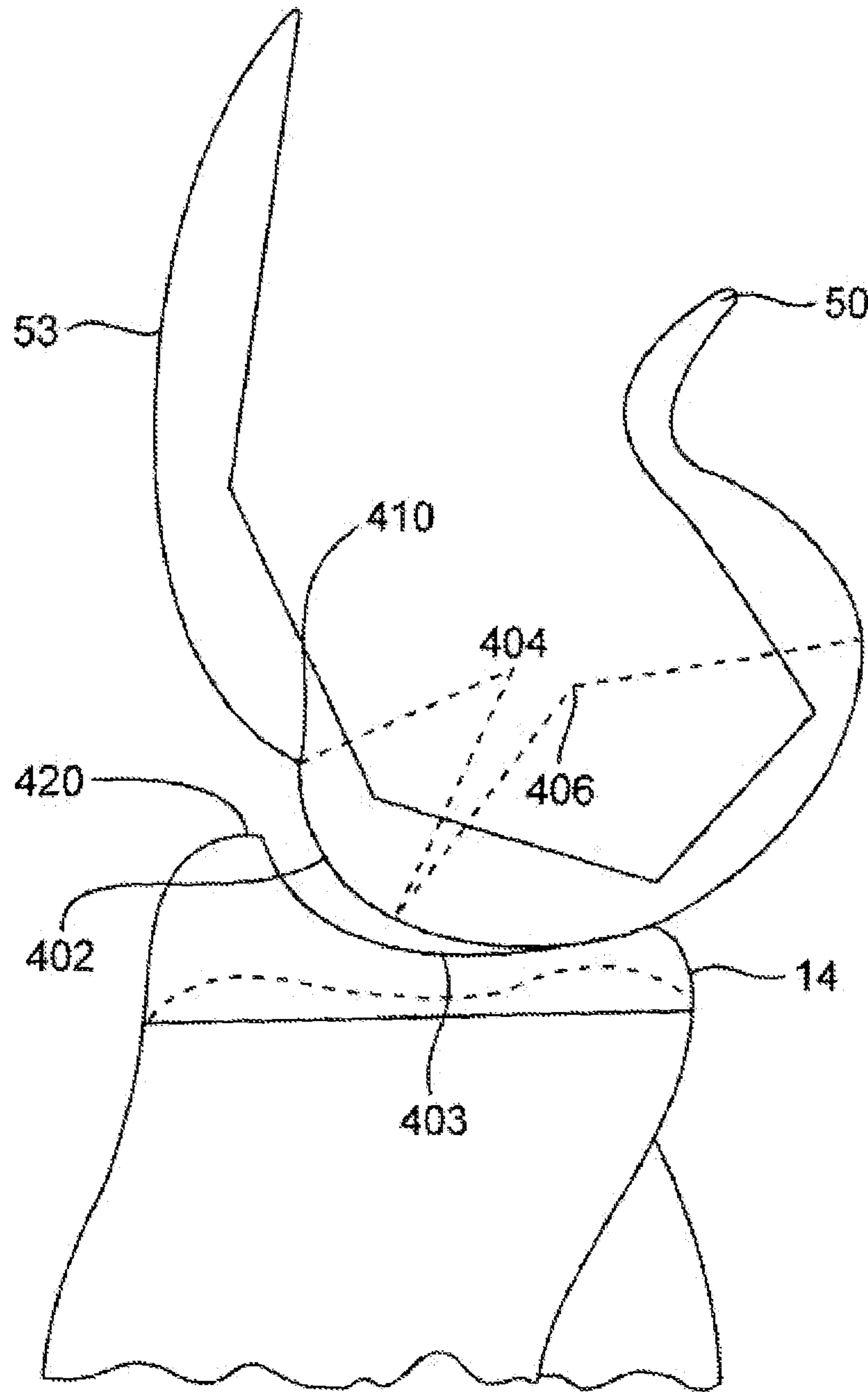

Figure 16J

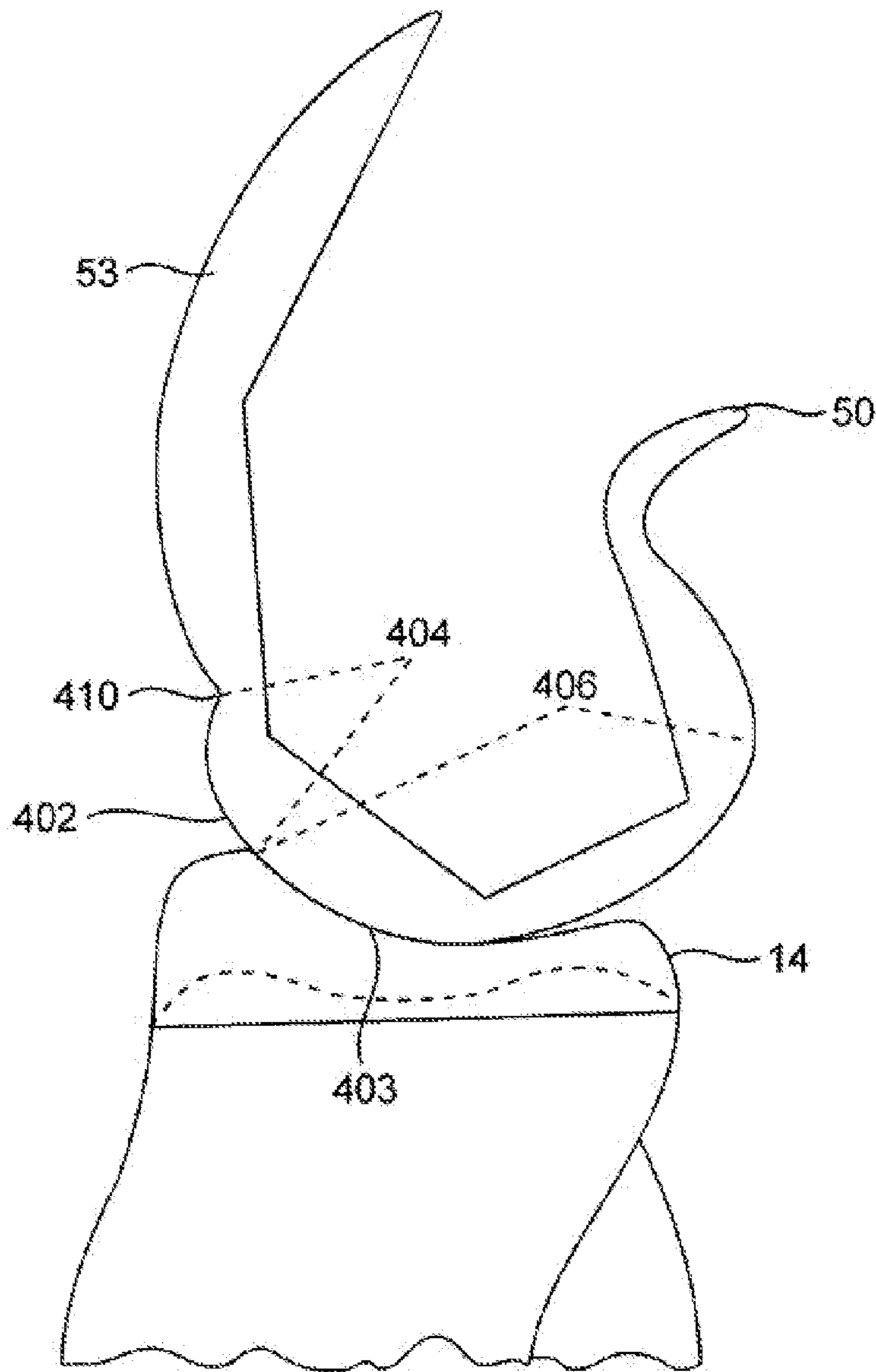

Figure 16K

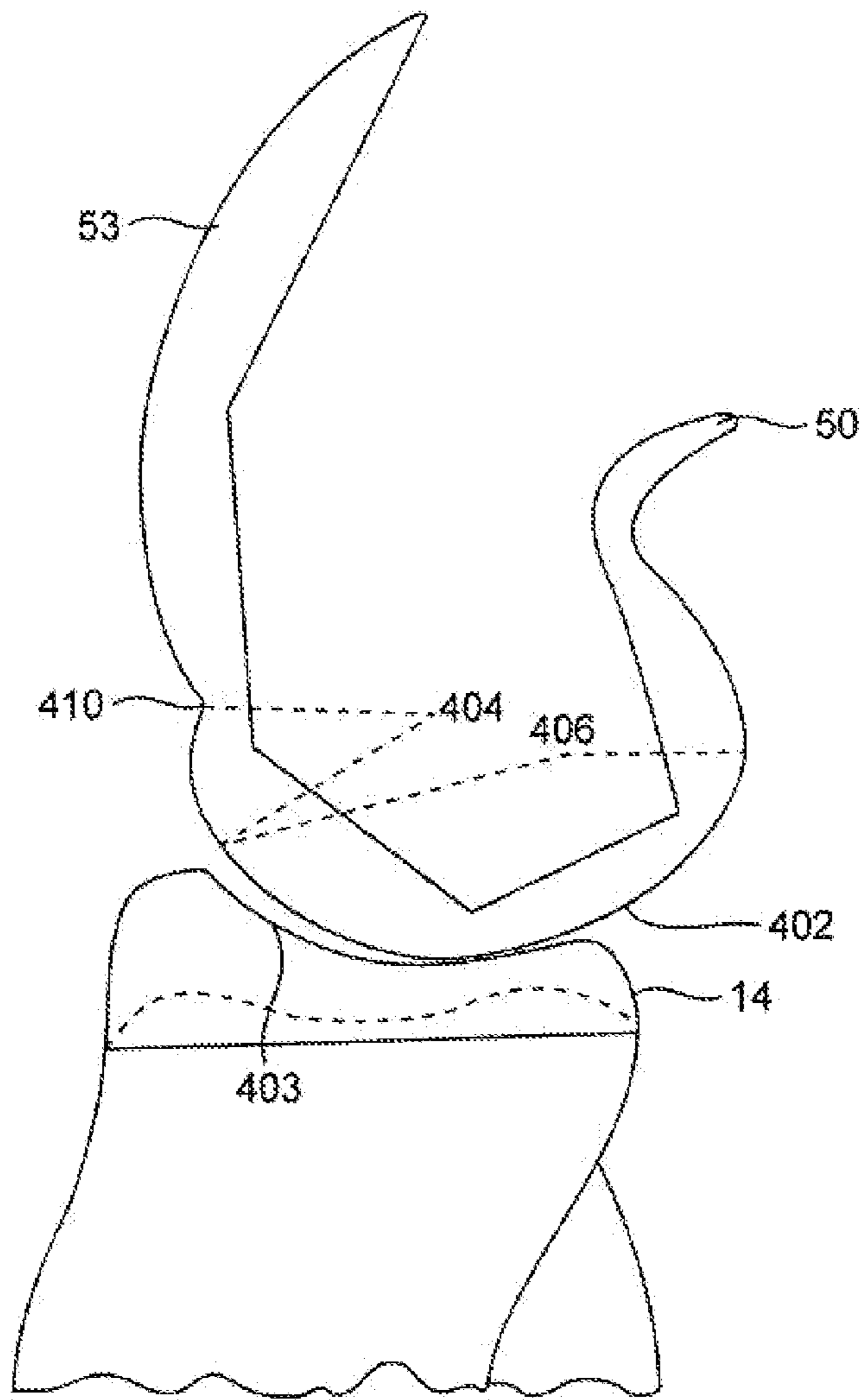

Figure 16L

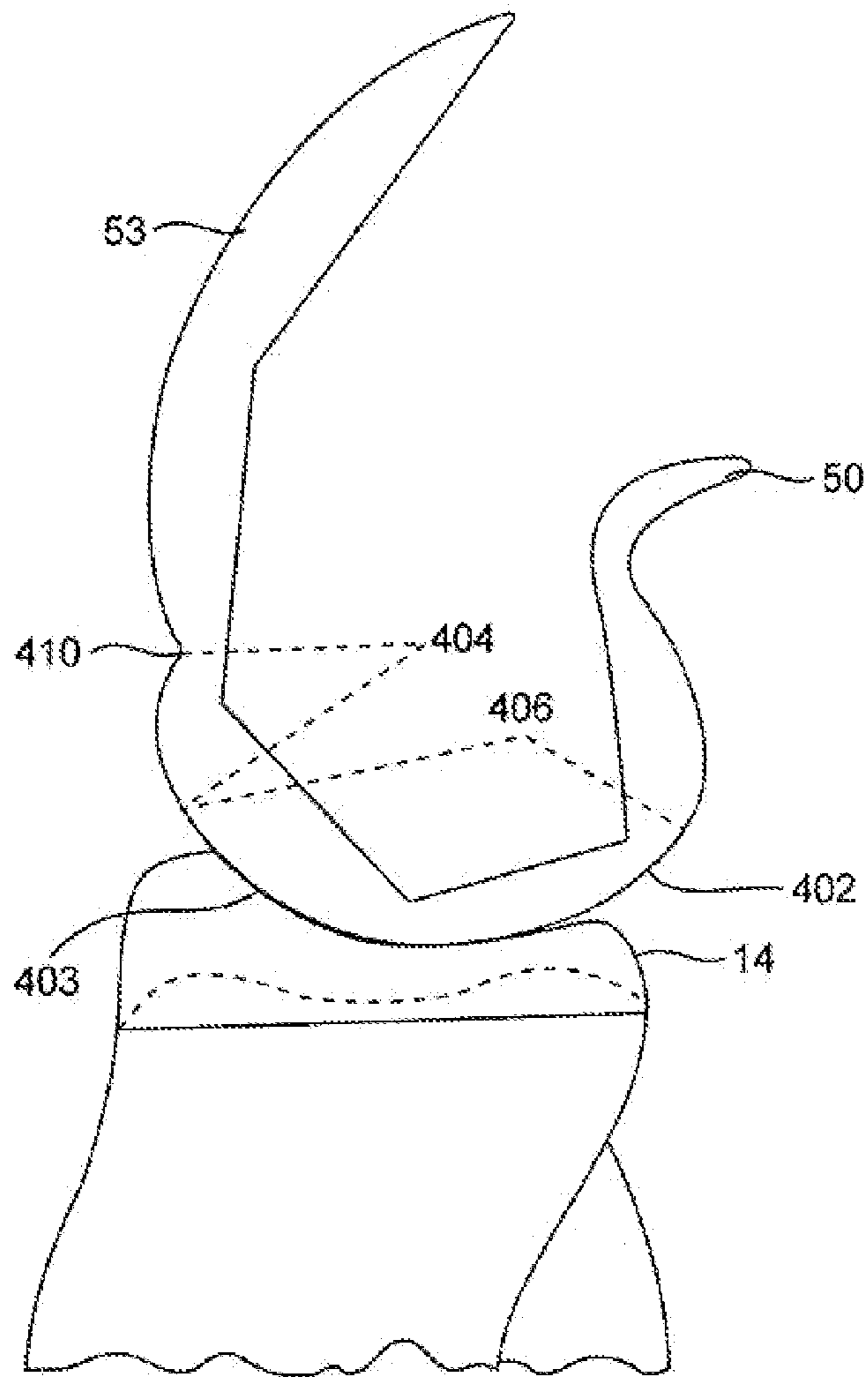

Figure 16M

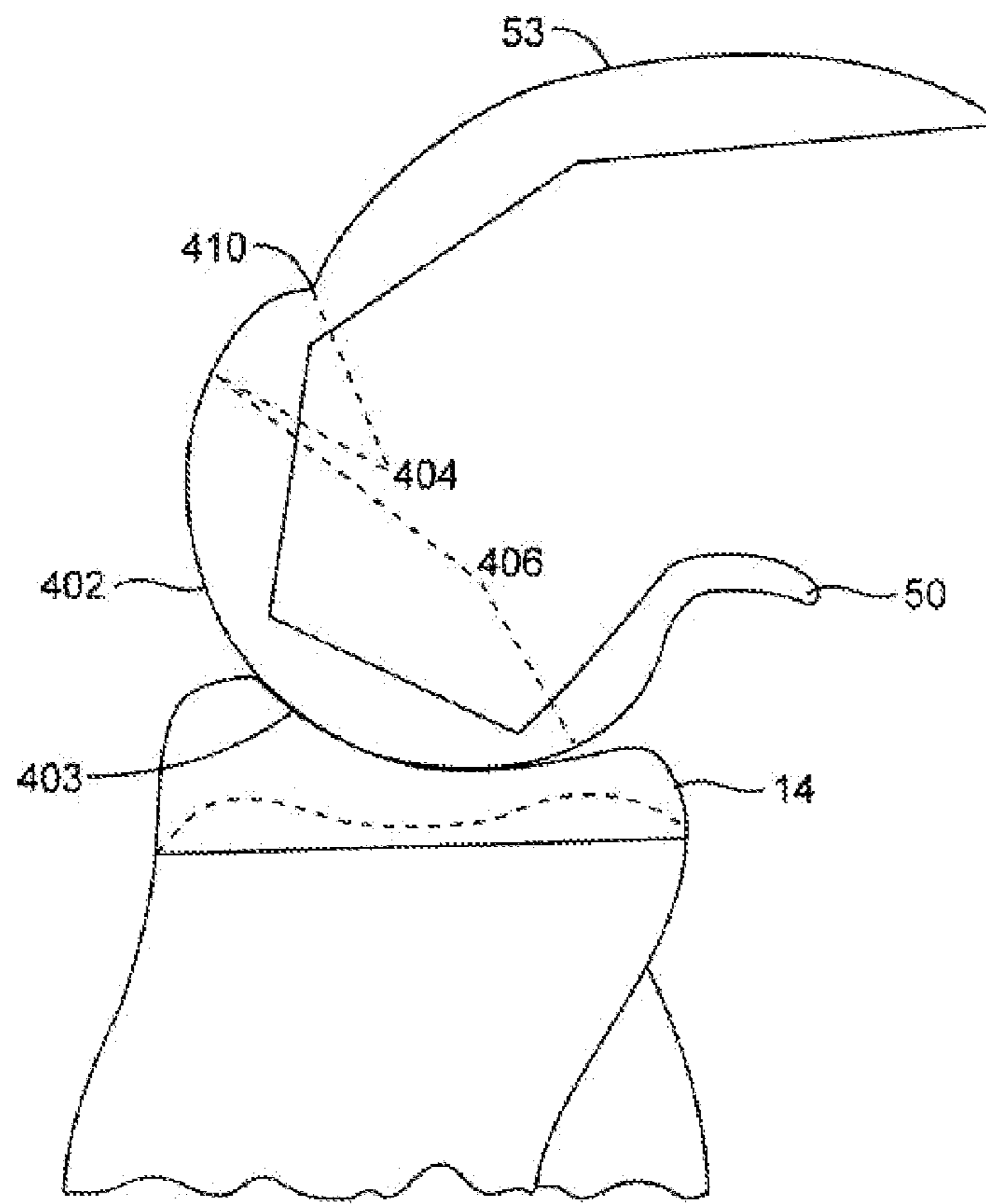

Figure 16N

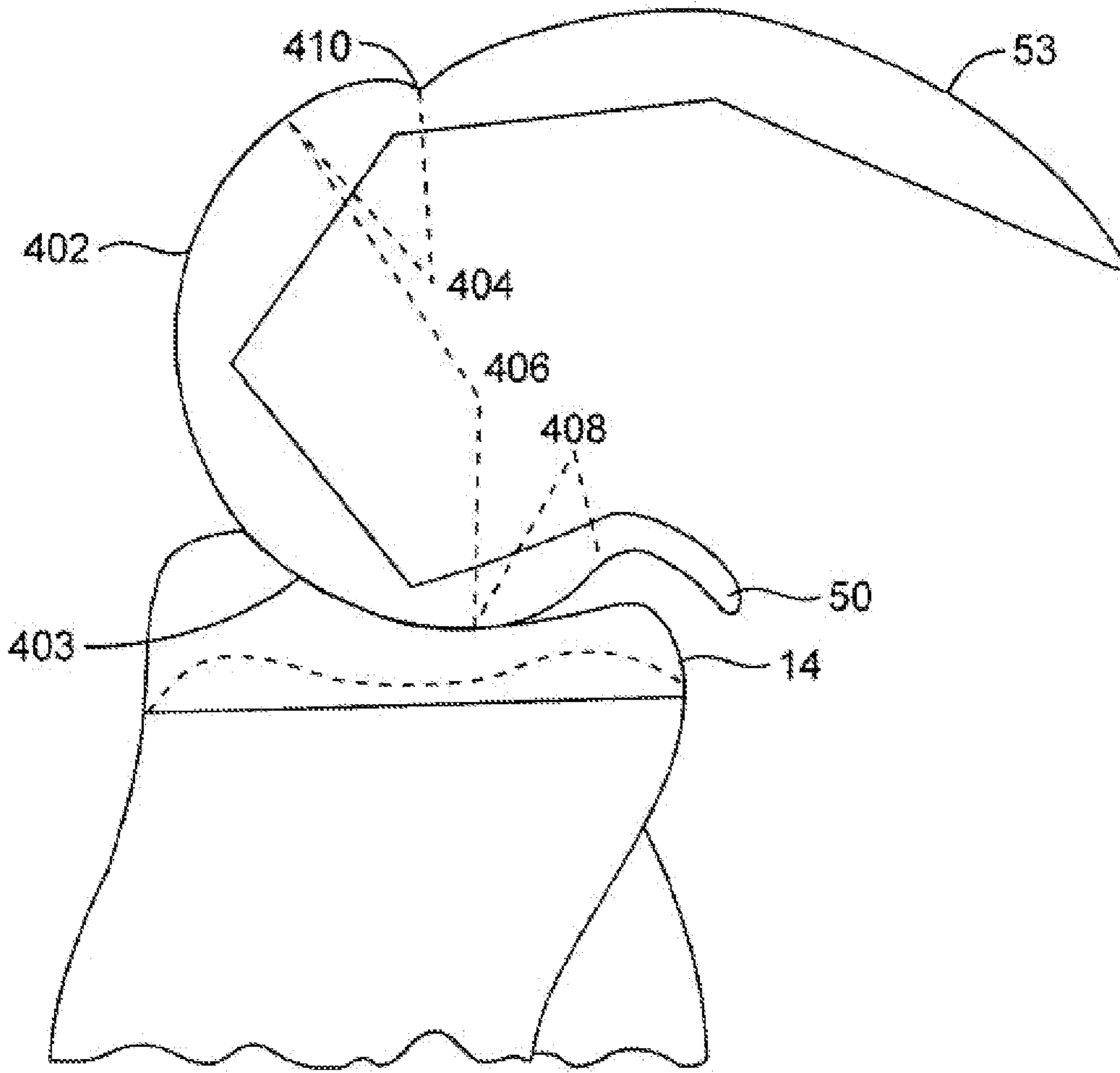

Figure 16O

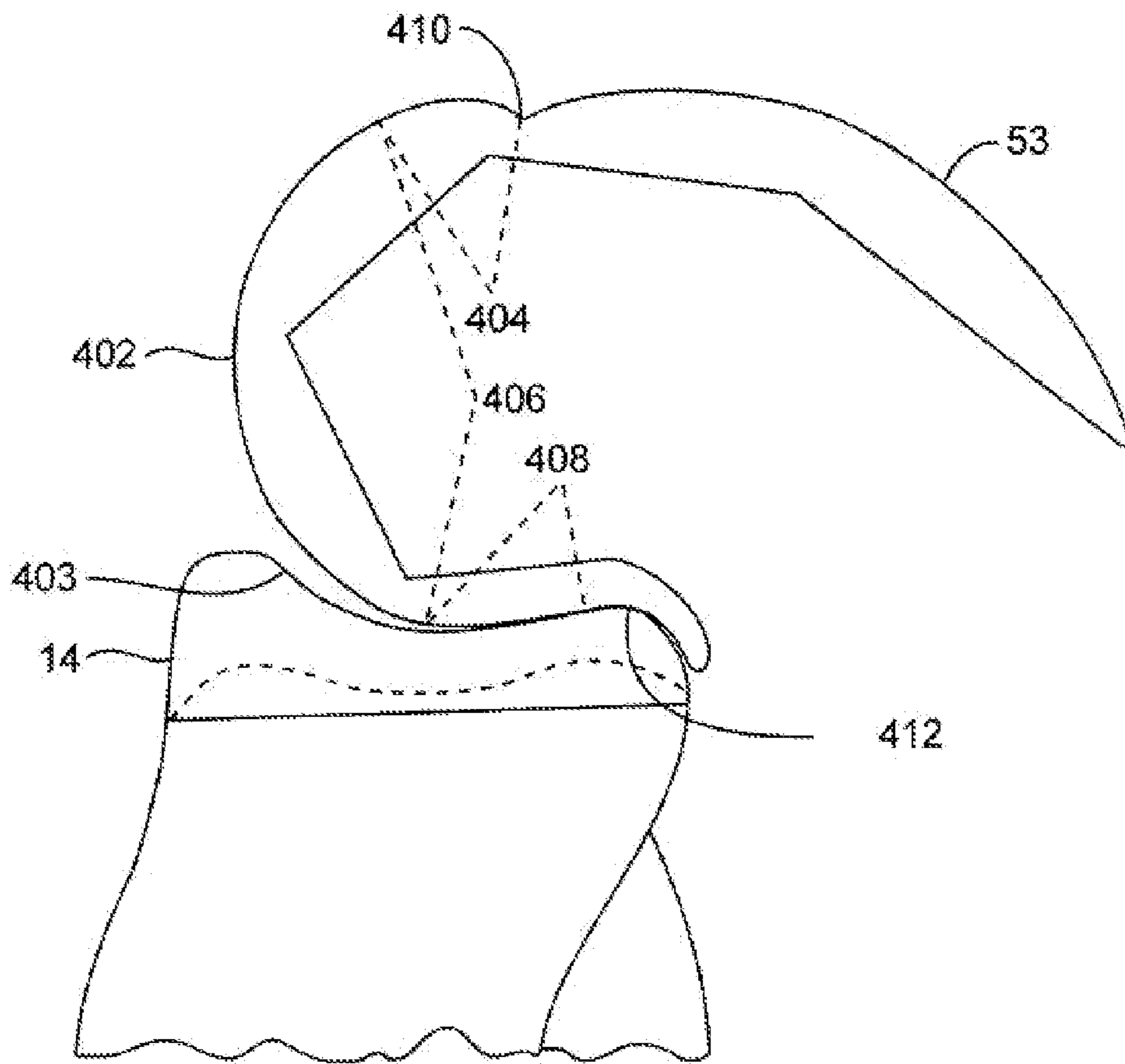

Figure 16P

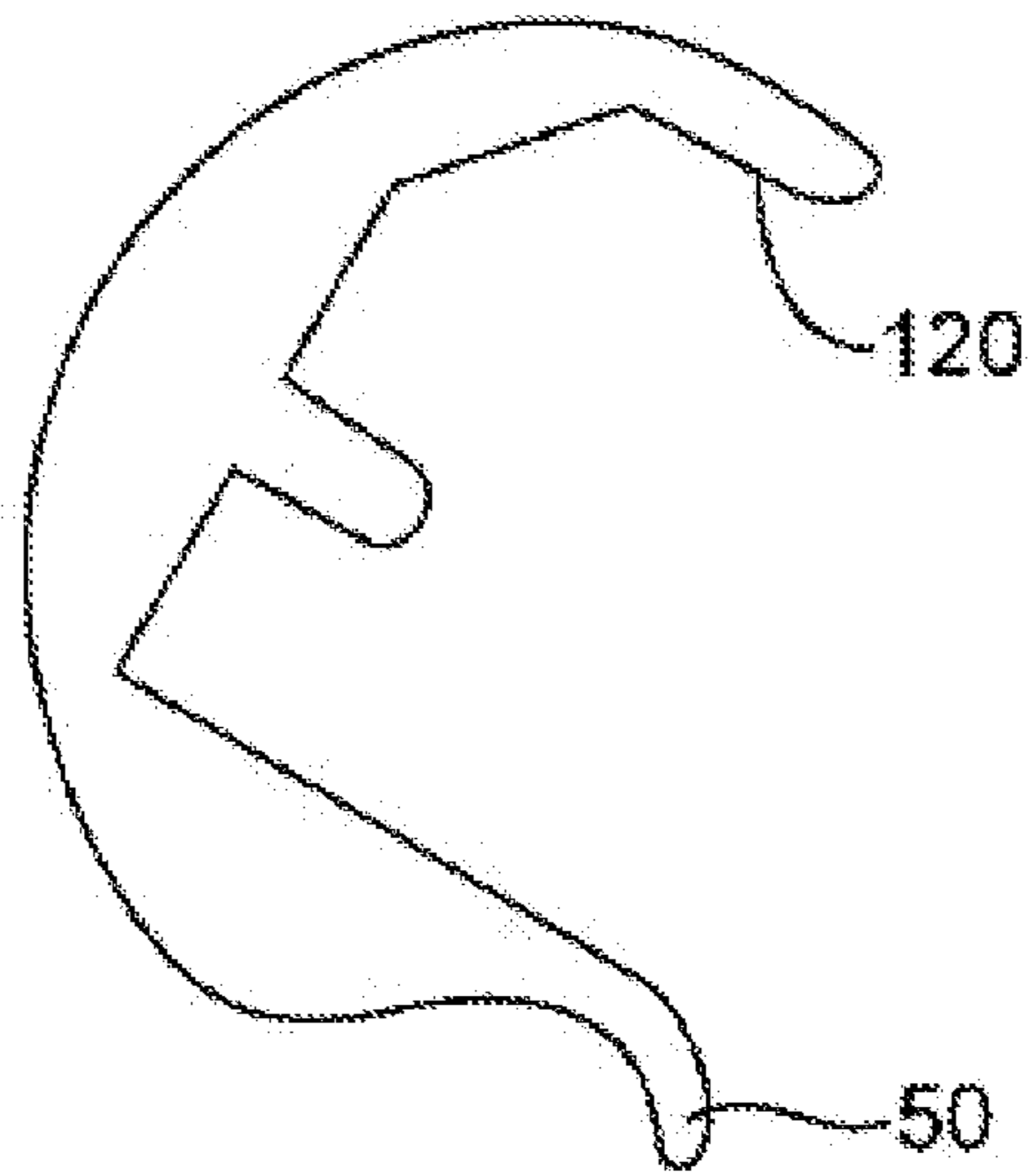

Figure 16Q

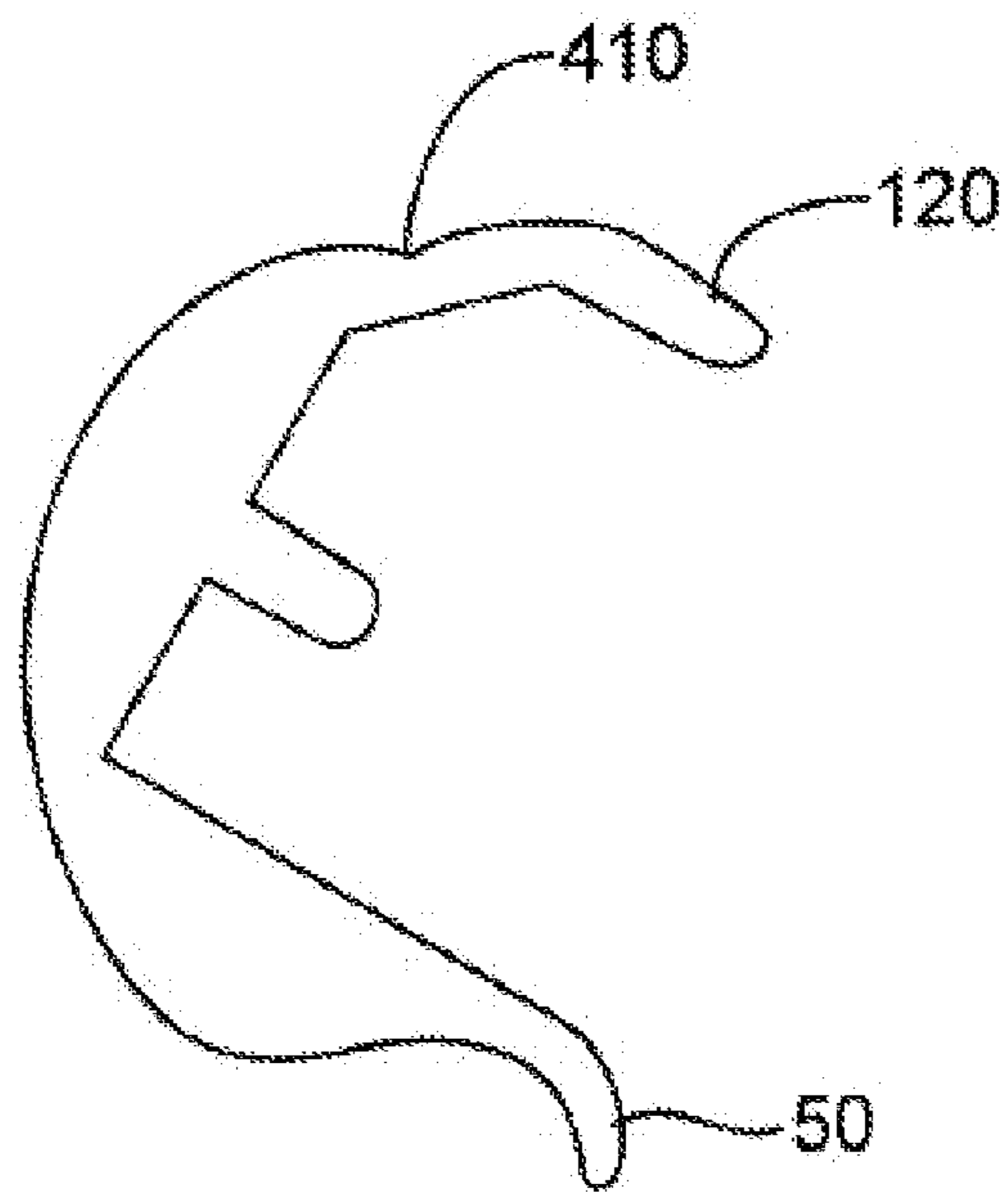

Figure 16R

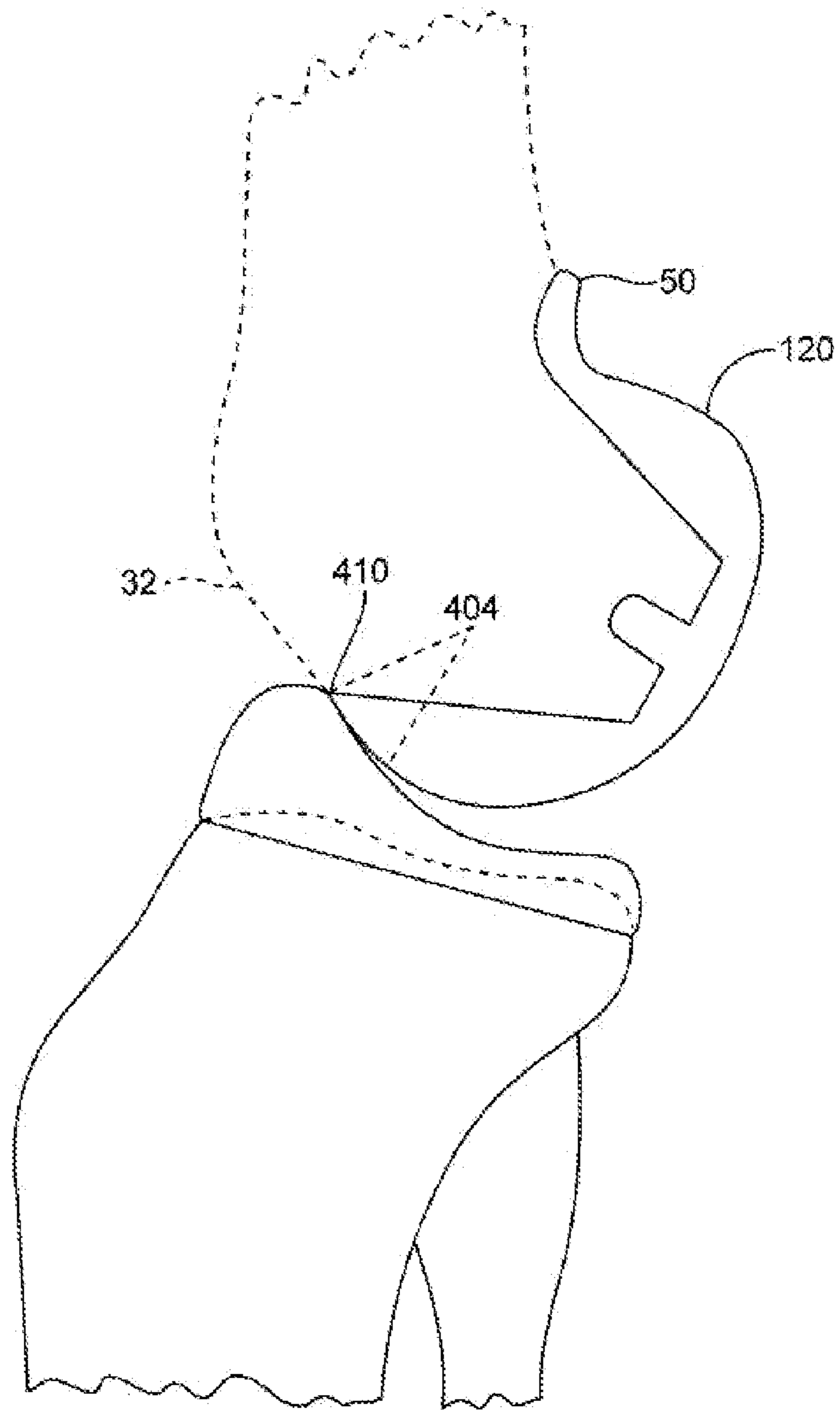

Figure 16S

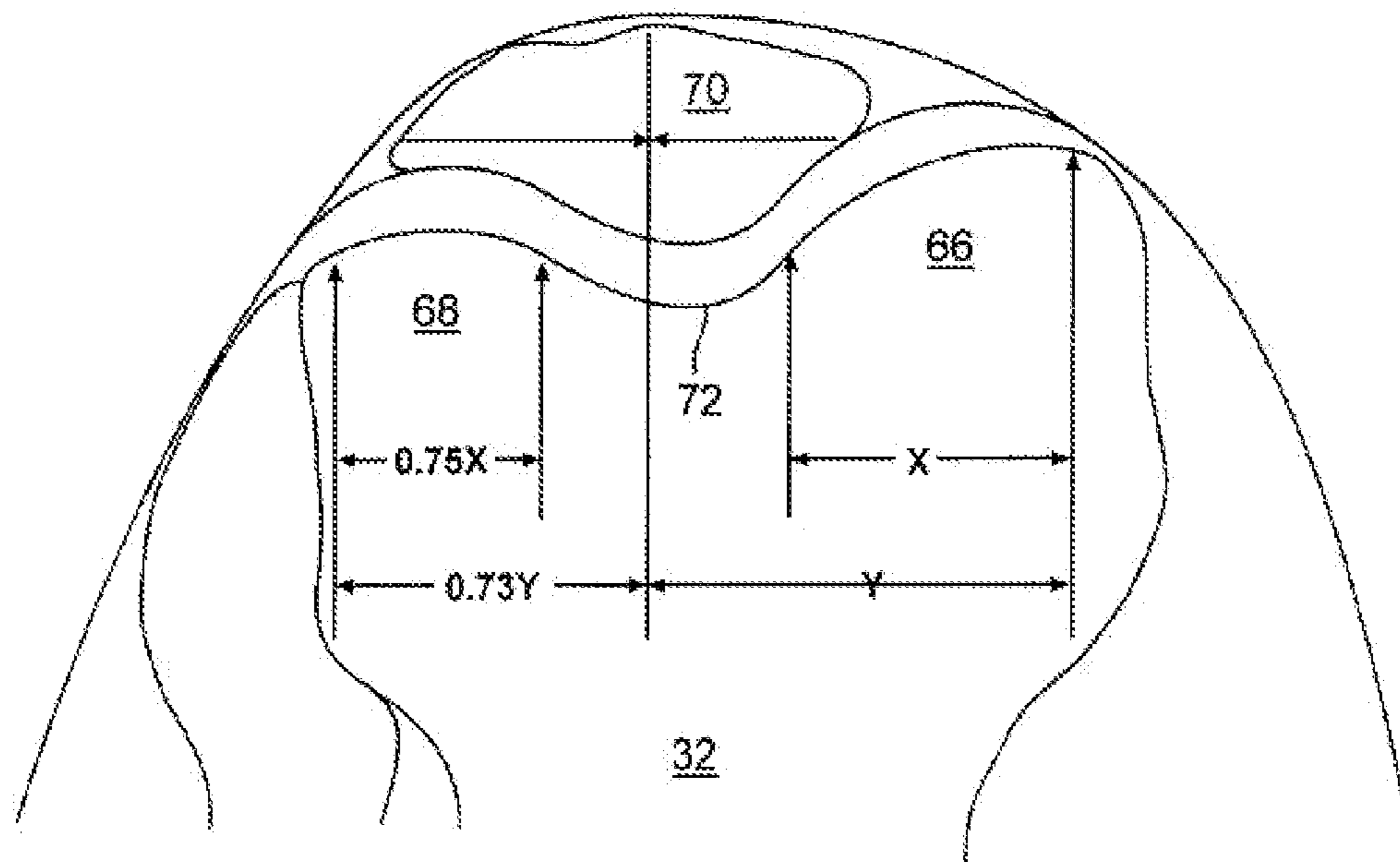

Figure 17

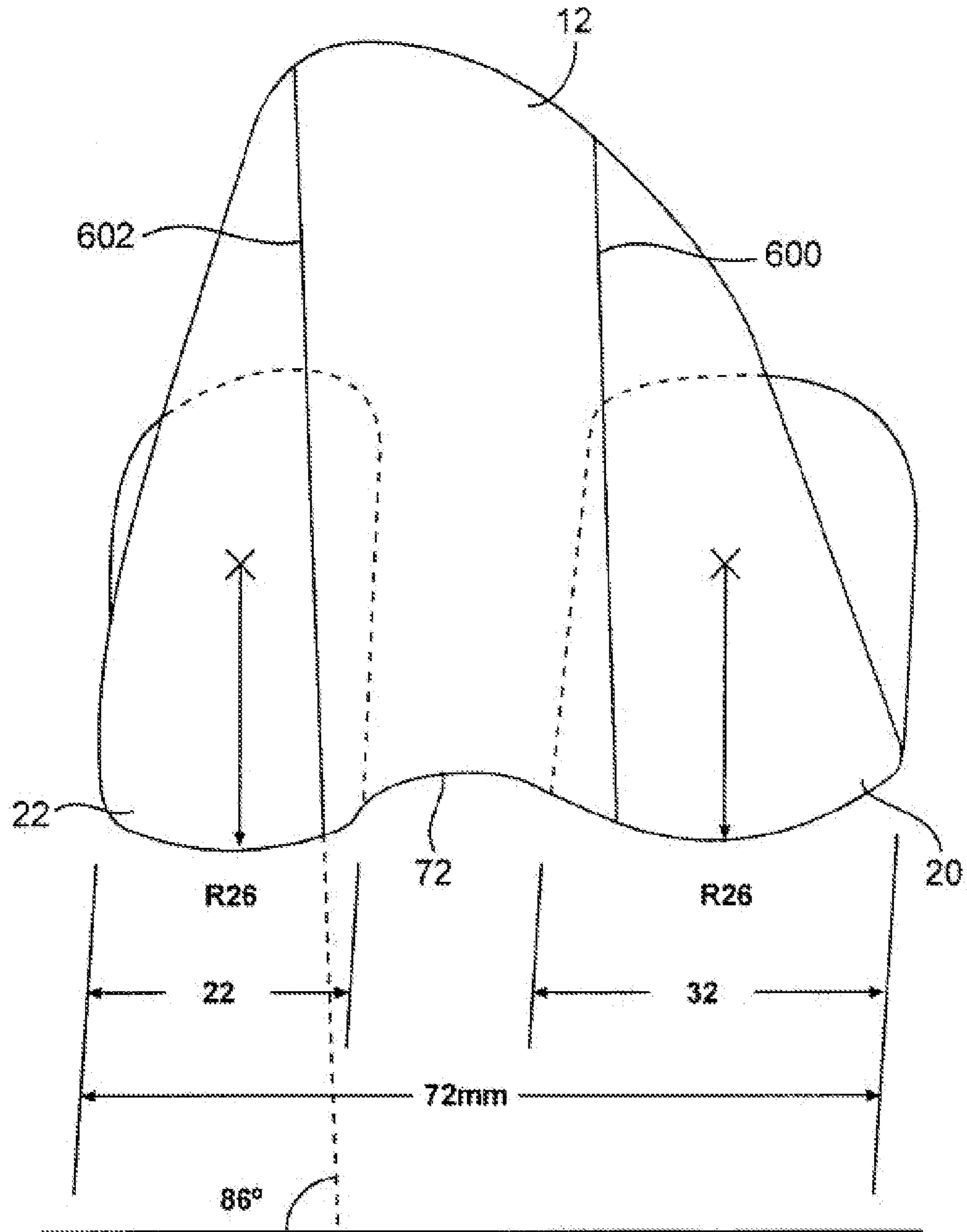

Figure 18A

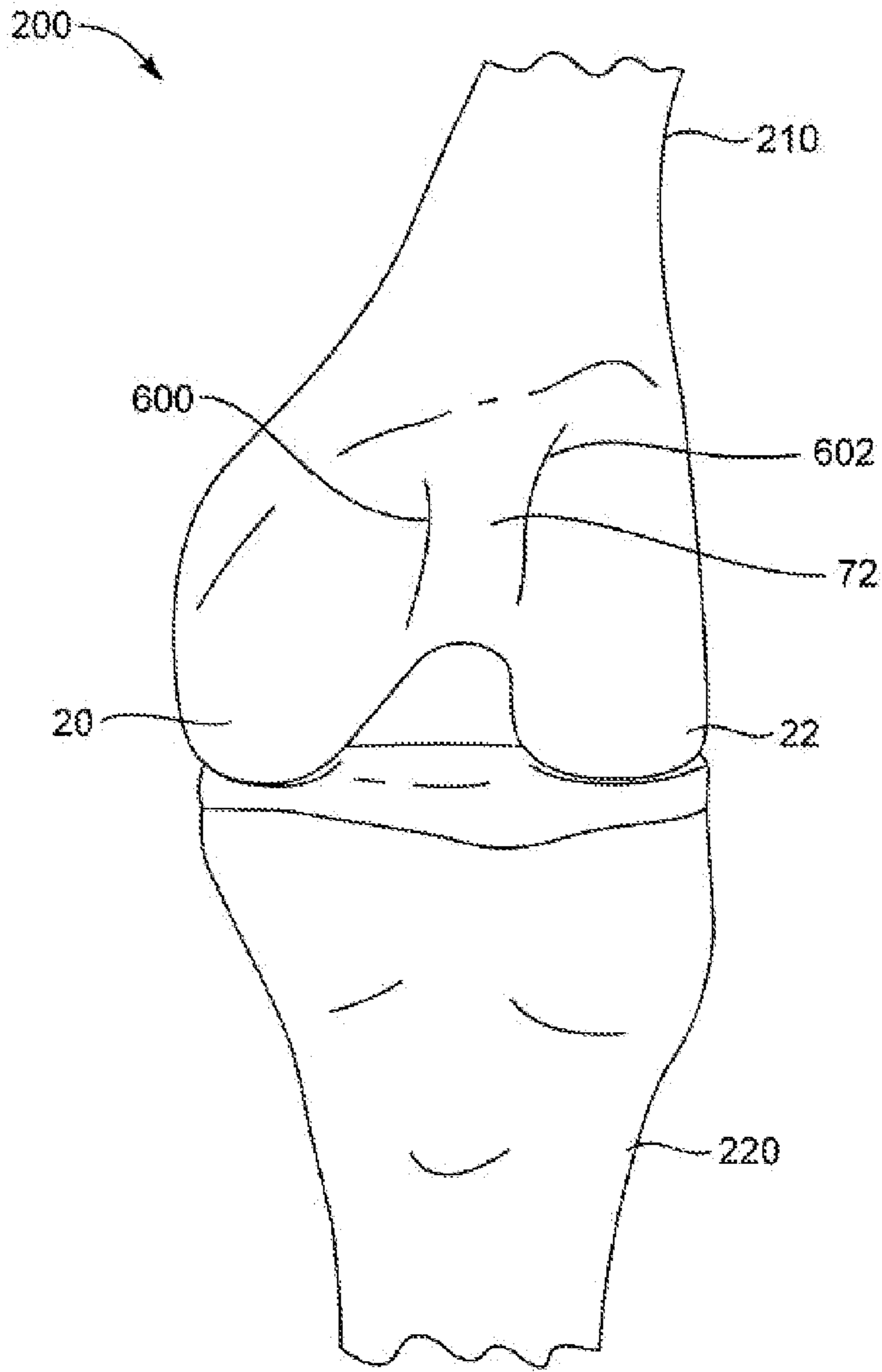

Figure 18B

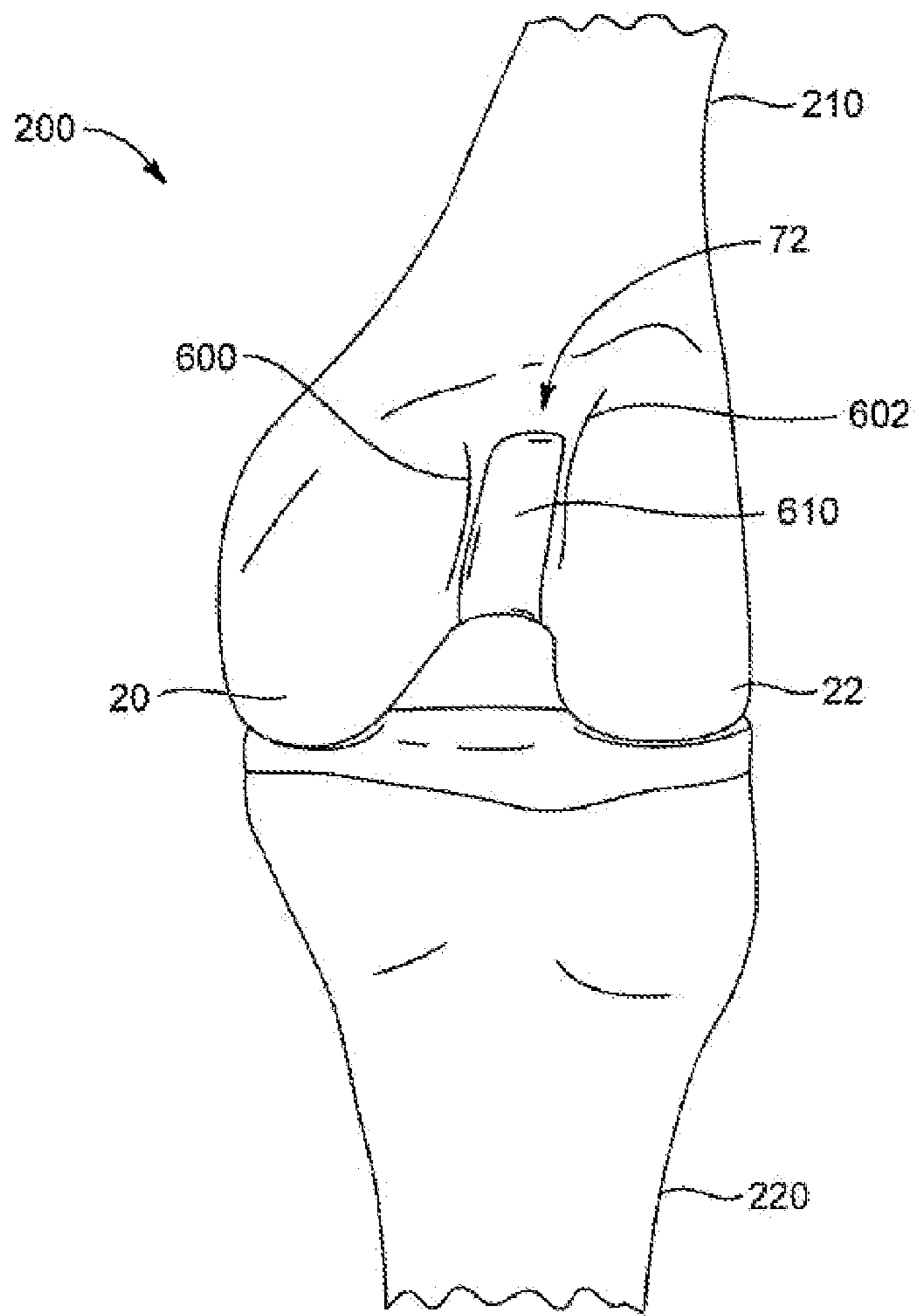

Figure 18C

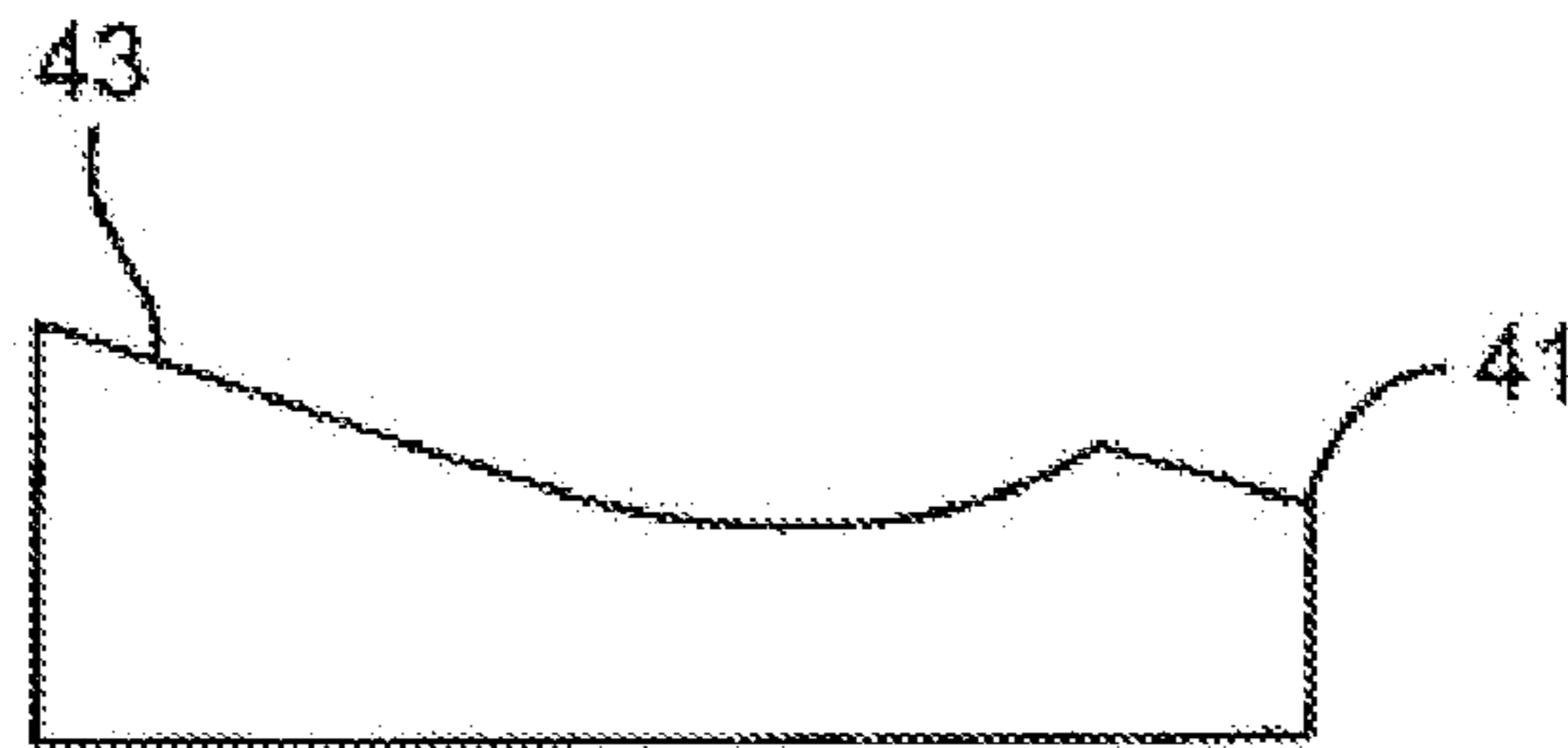

Figure 19A



Figure 19B

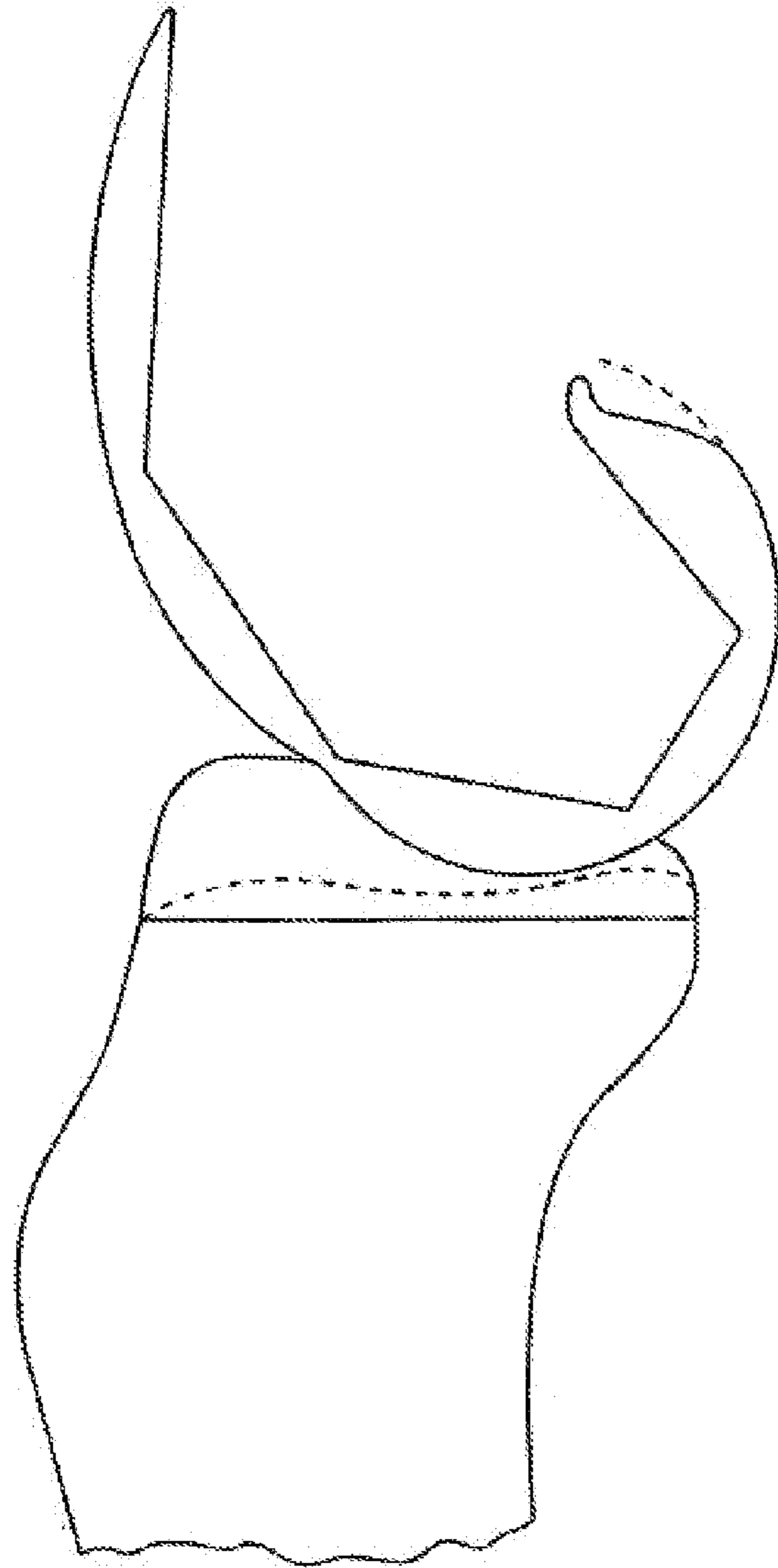

Figure 20A

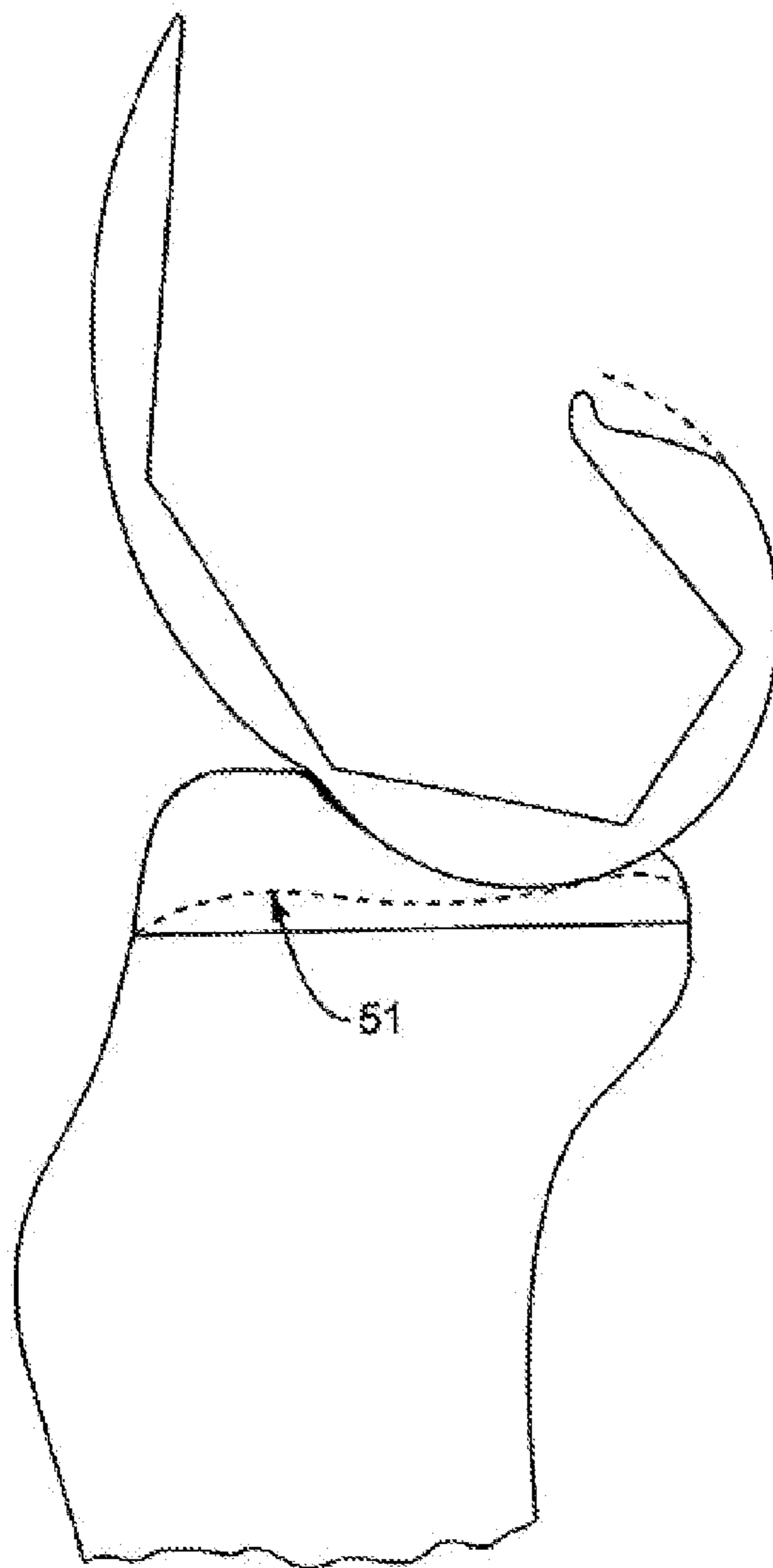

Figure 20B

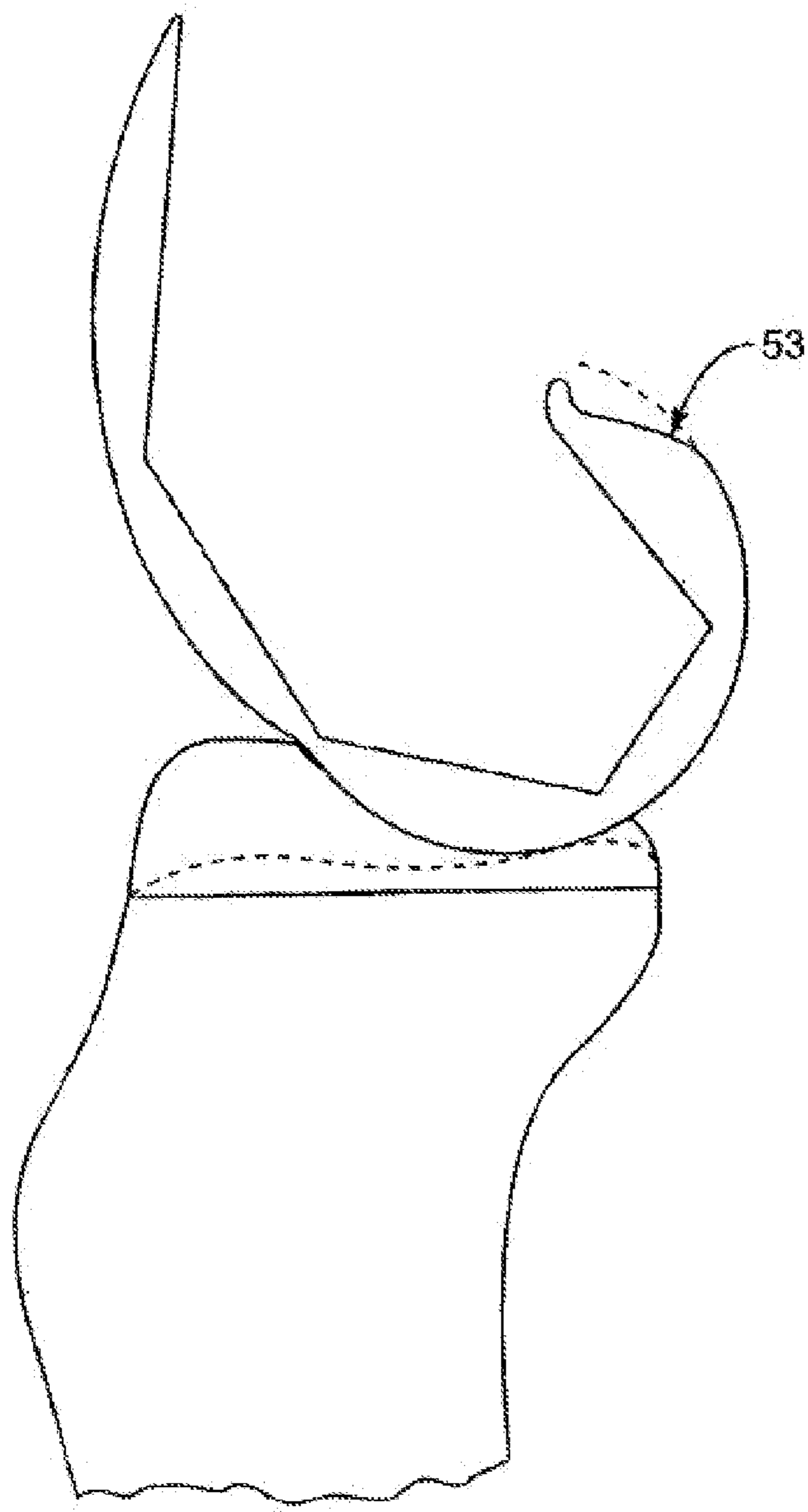

Figure 20C

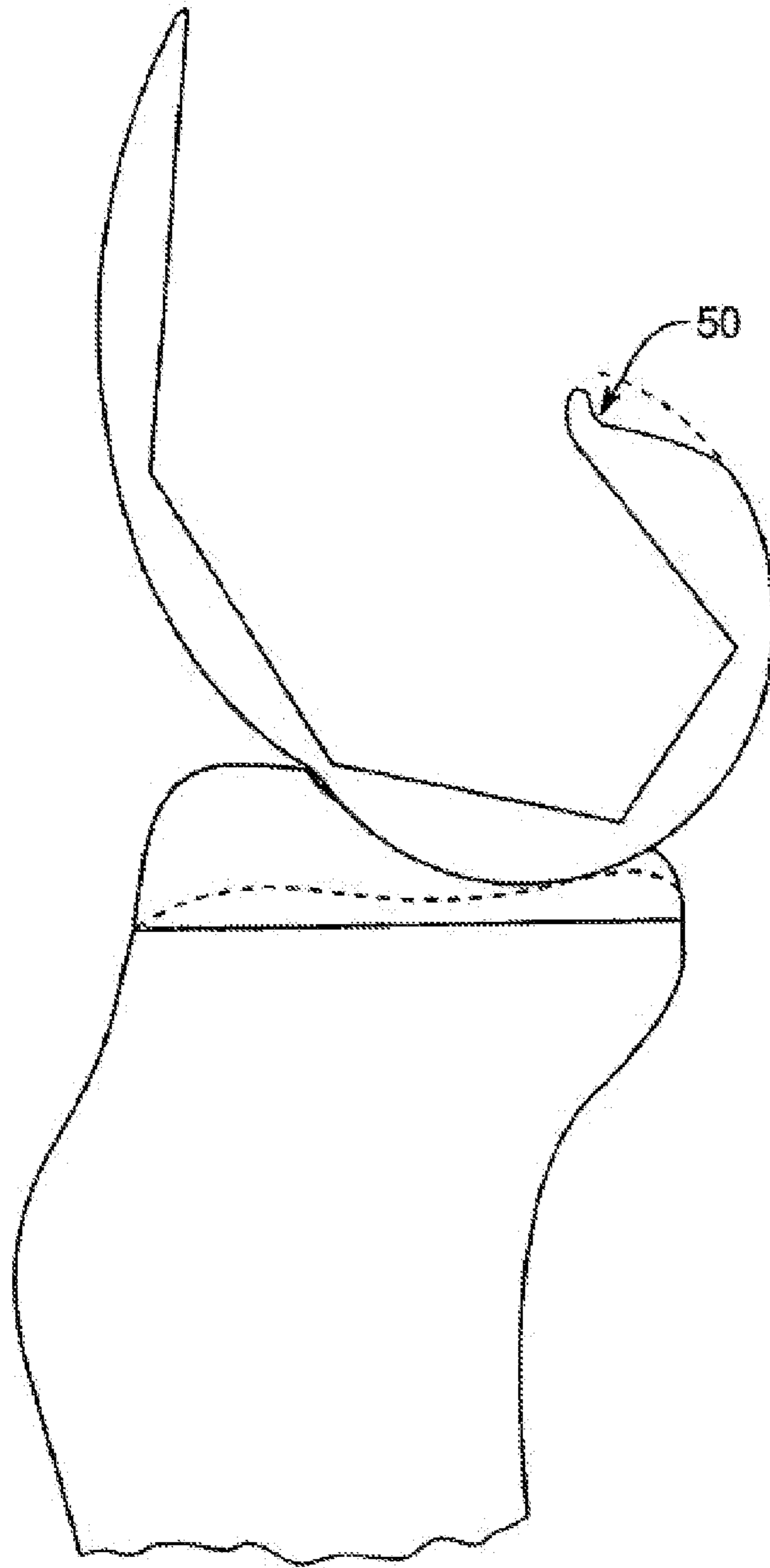

Figure 20D

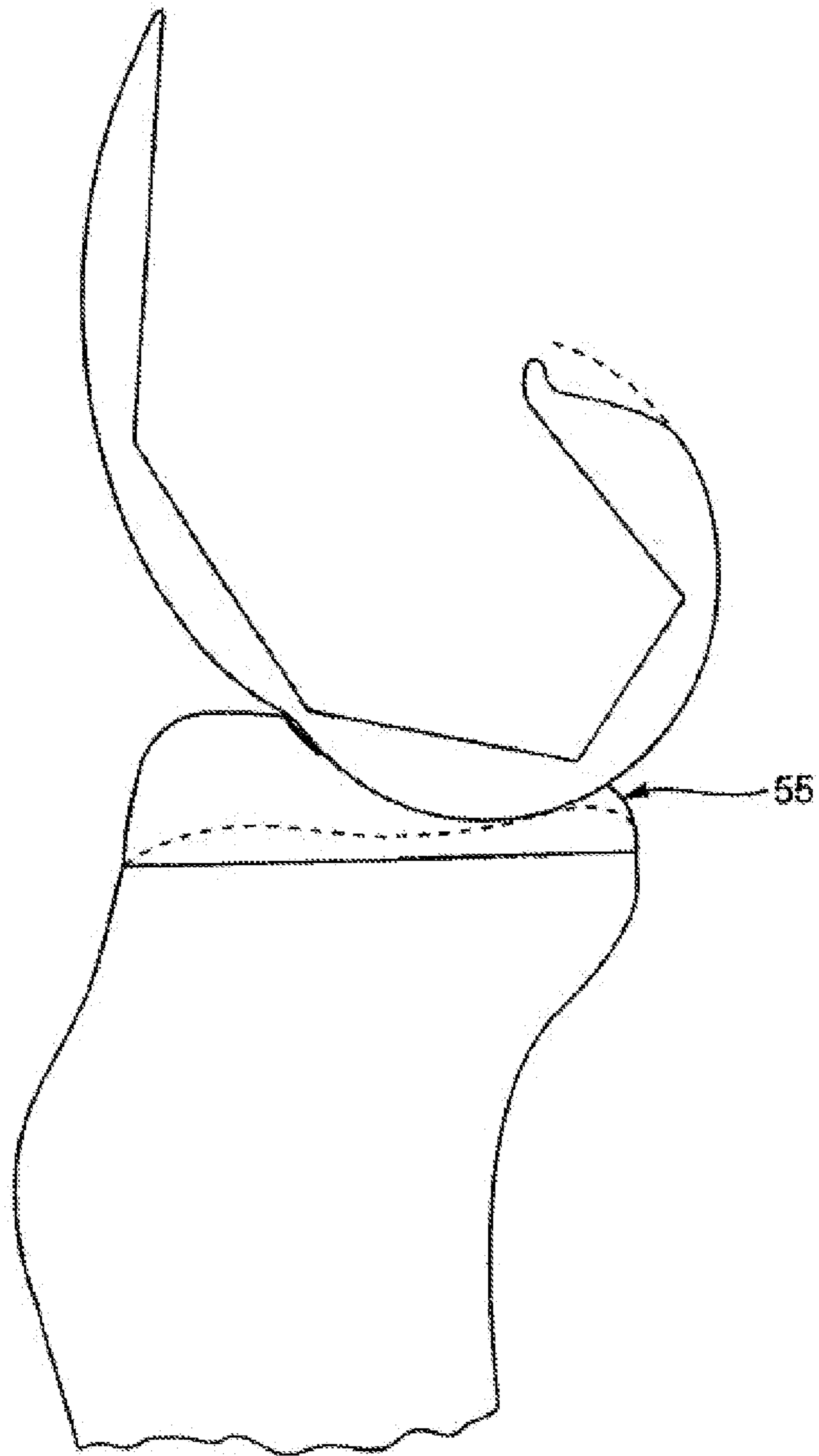

Figure 20E

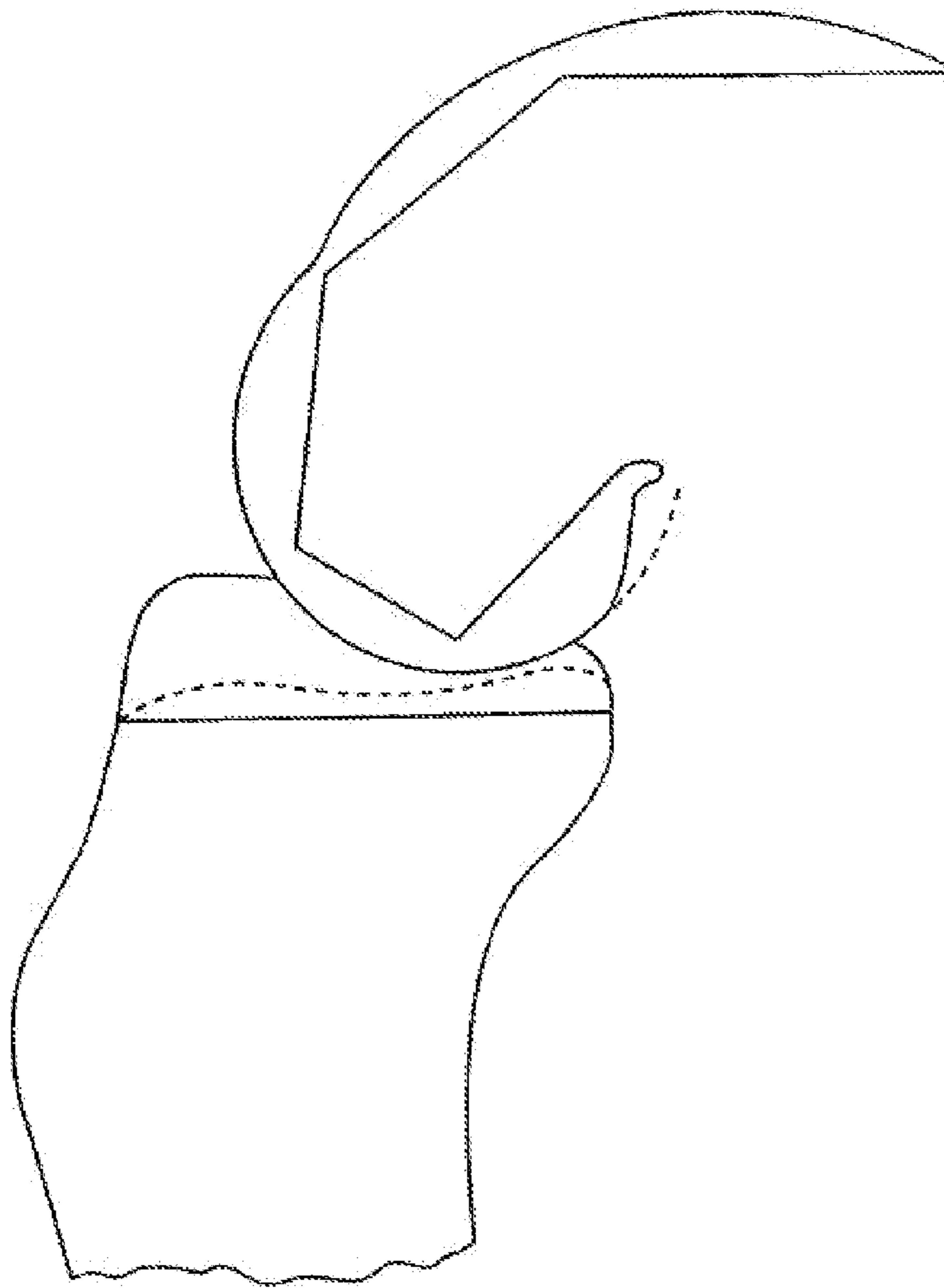

Figure 20F

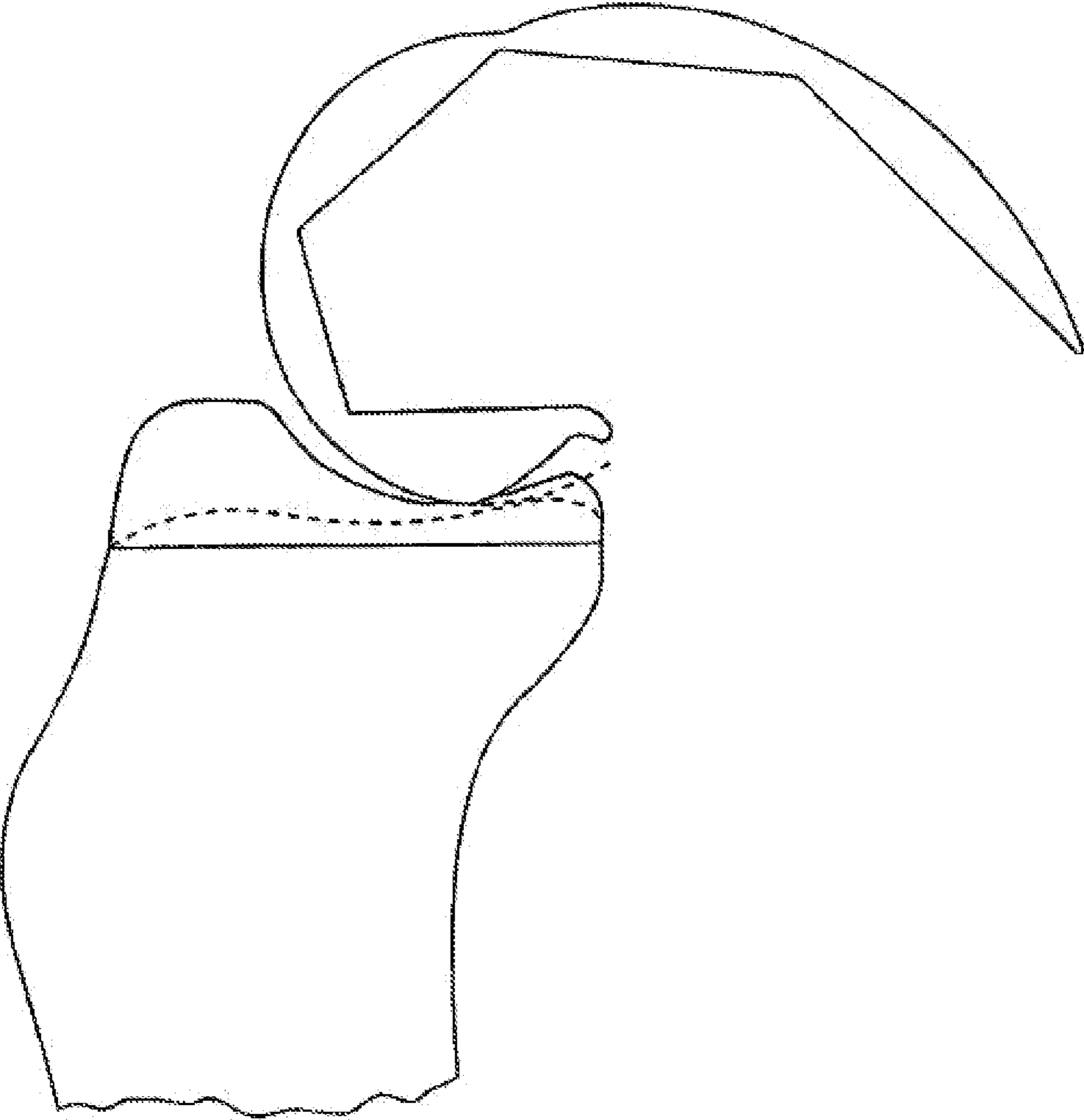

Figure 20G

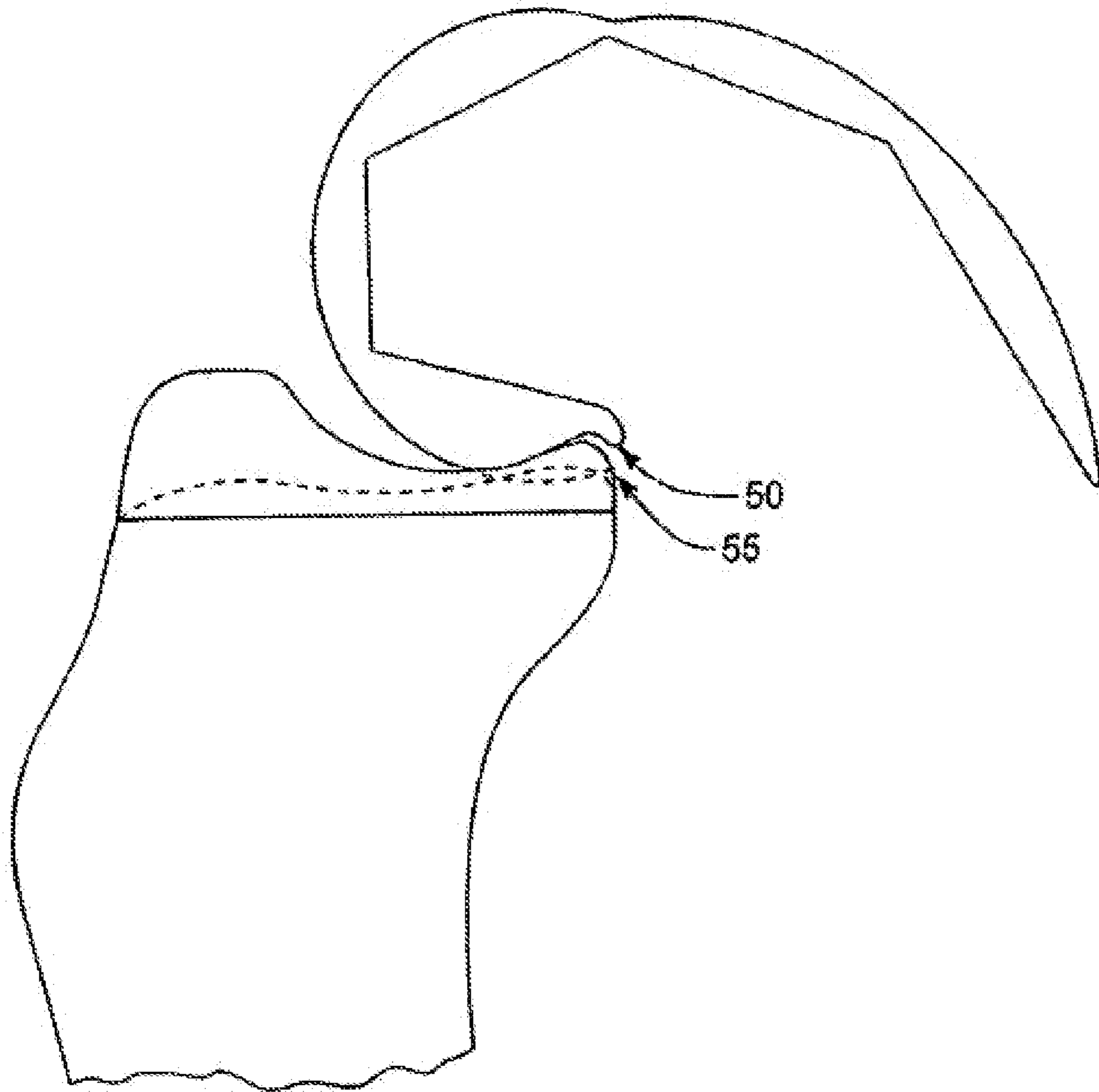

Figure 20H

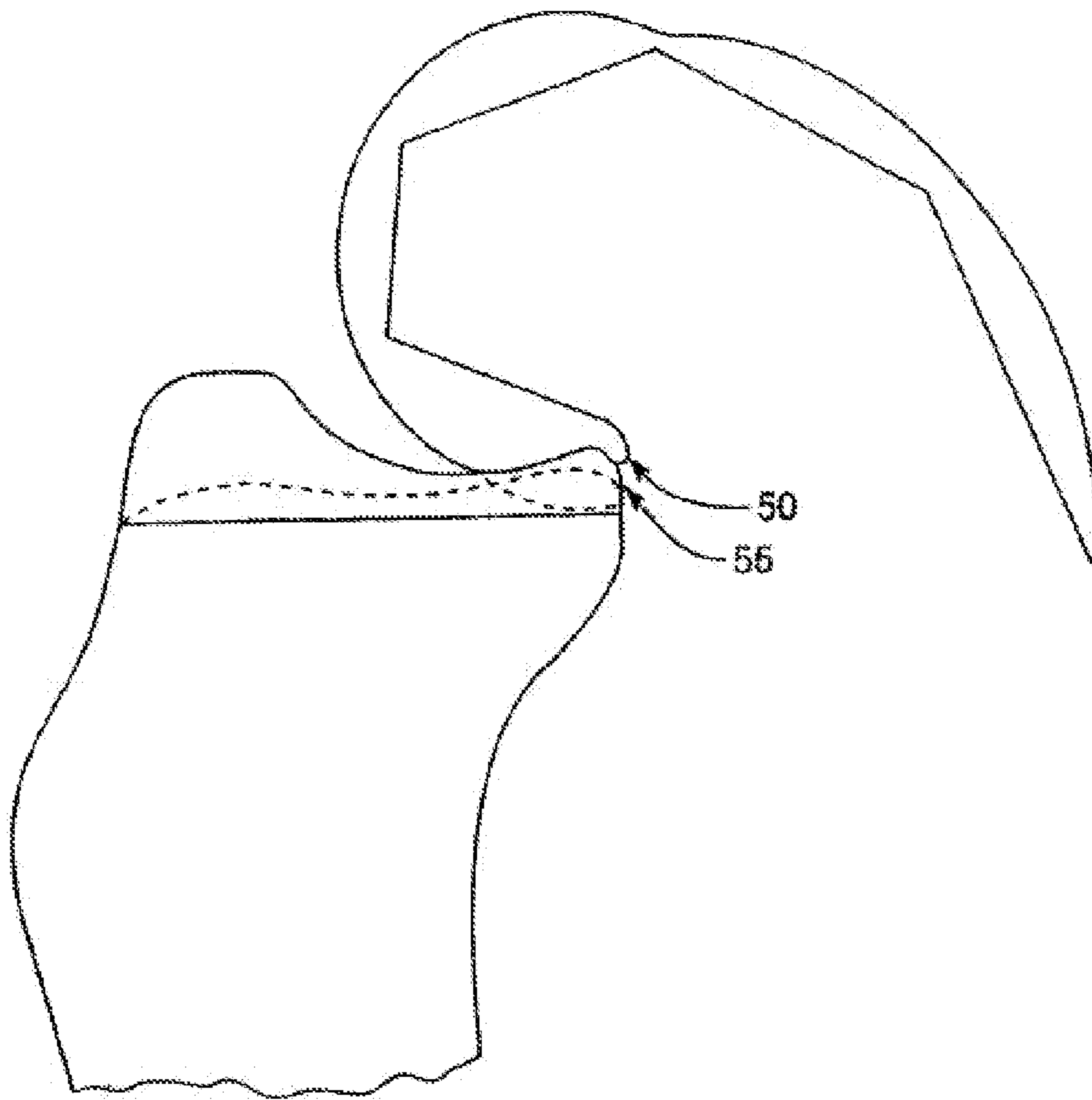

Figure 20I

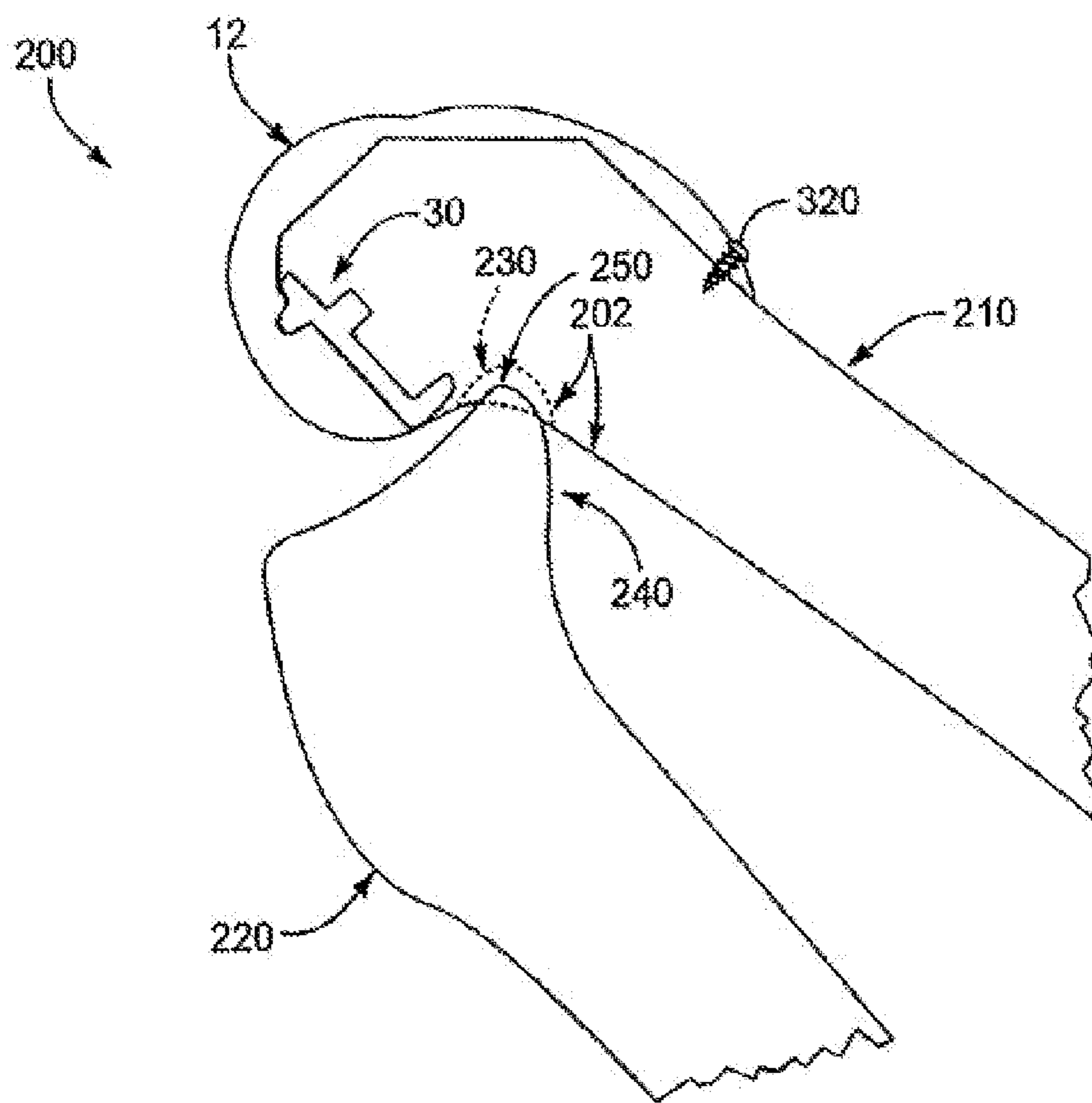

Figure 21

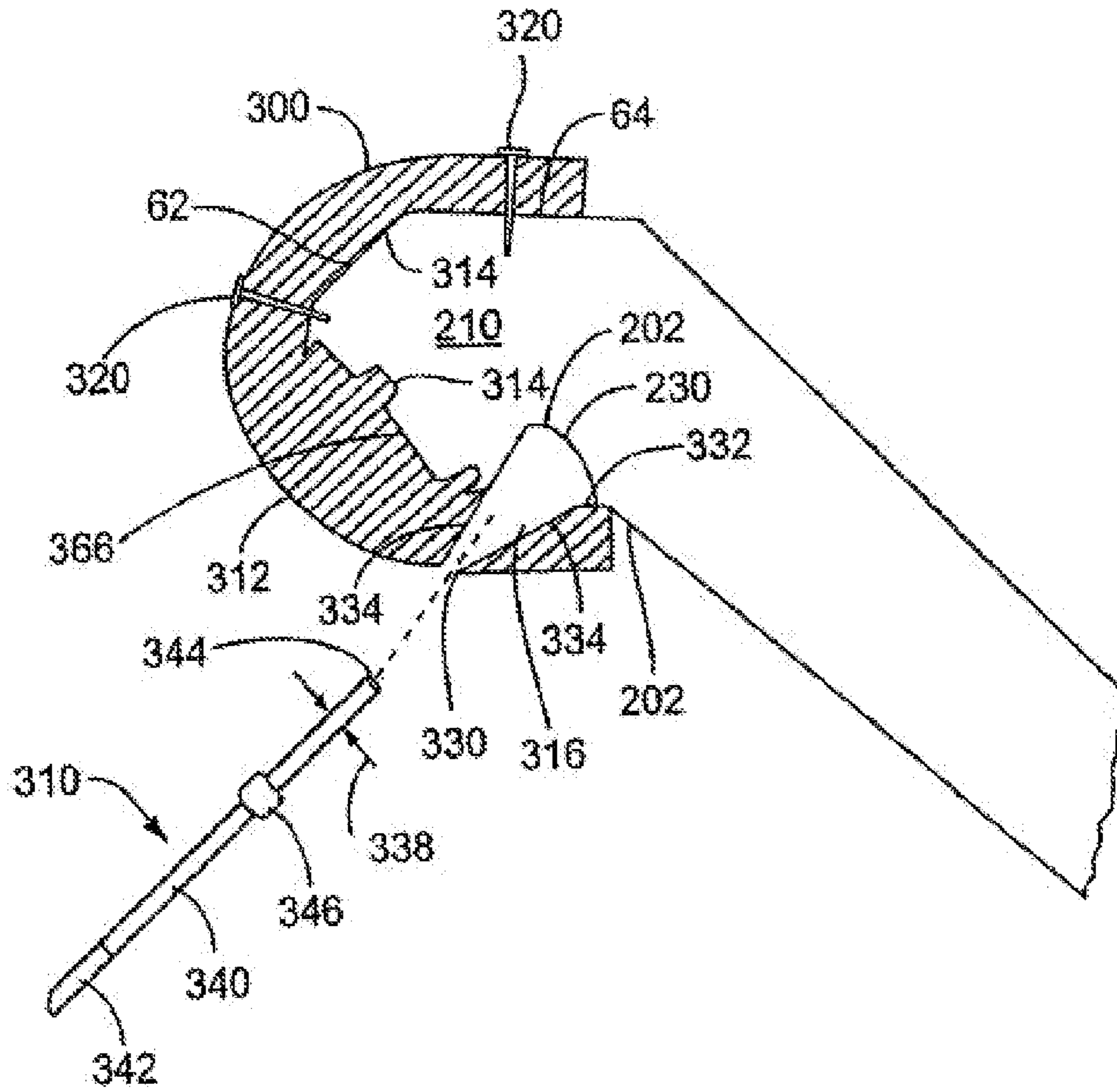

Figure 22

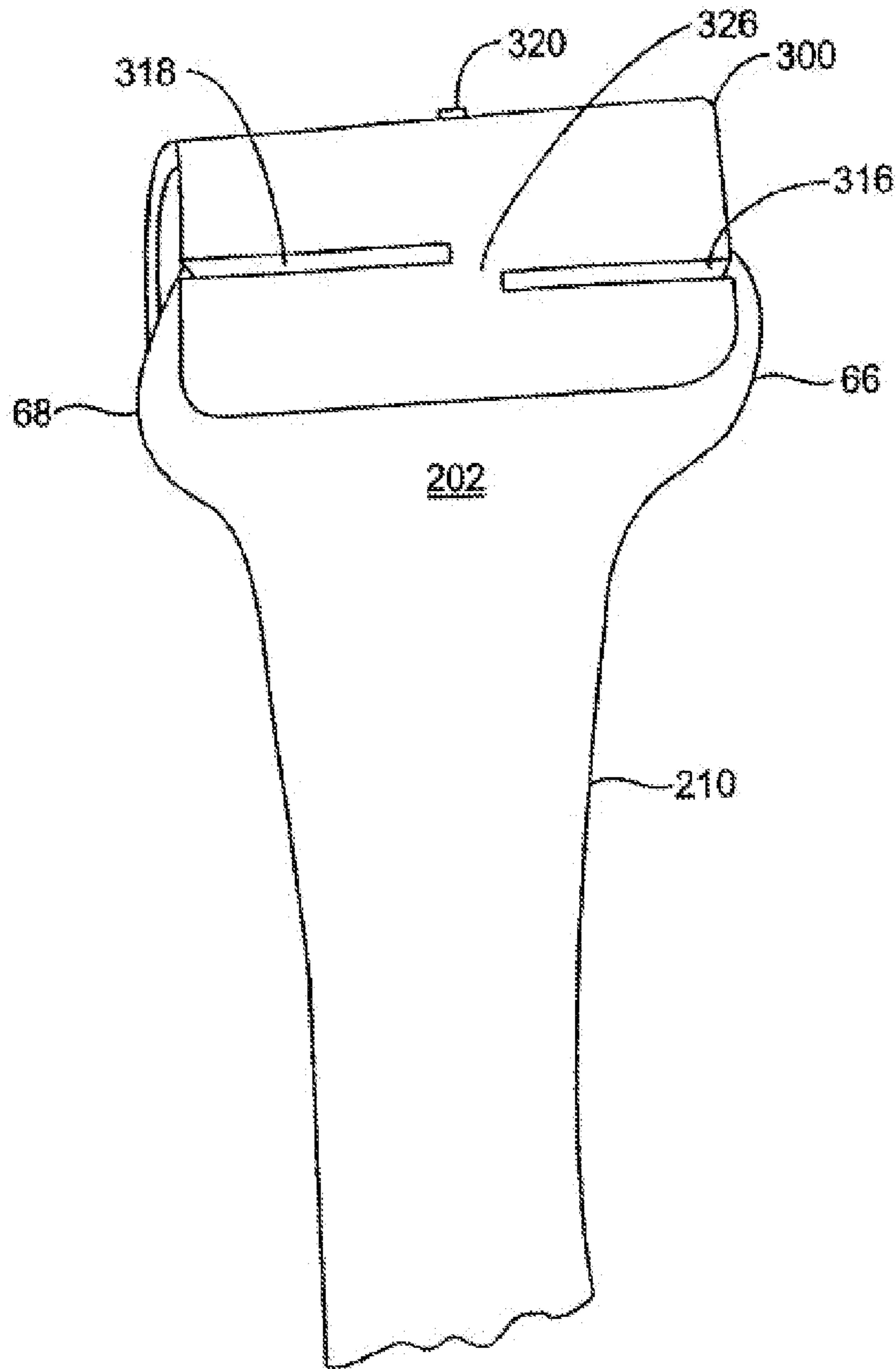

Figure 22A

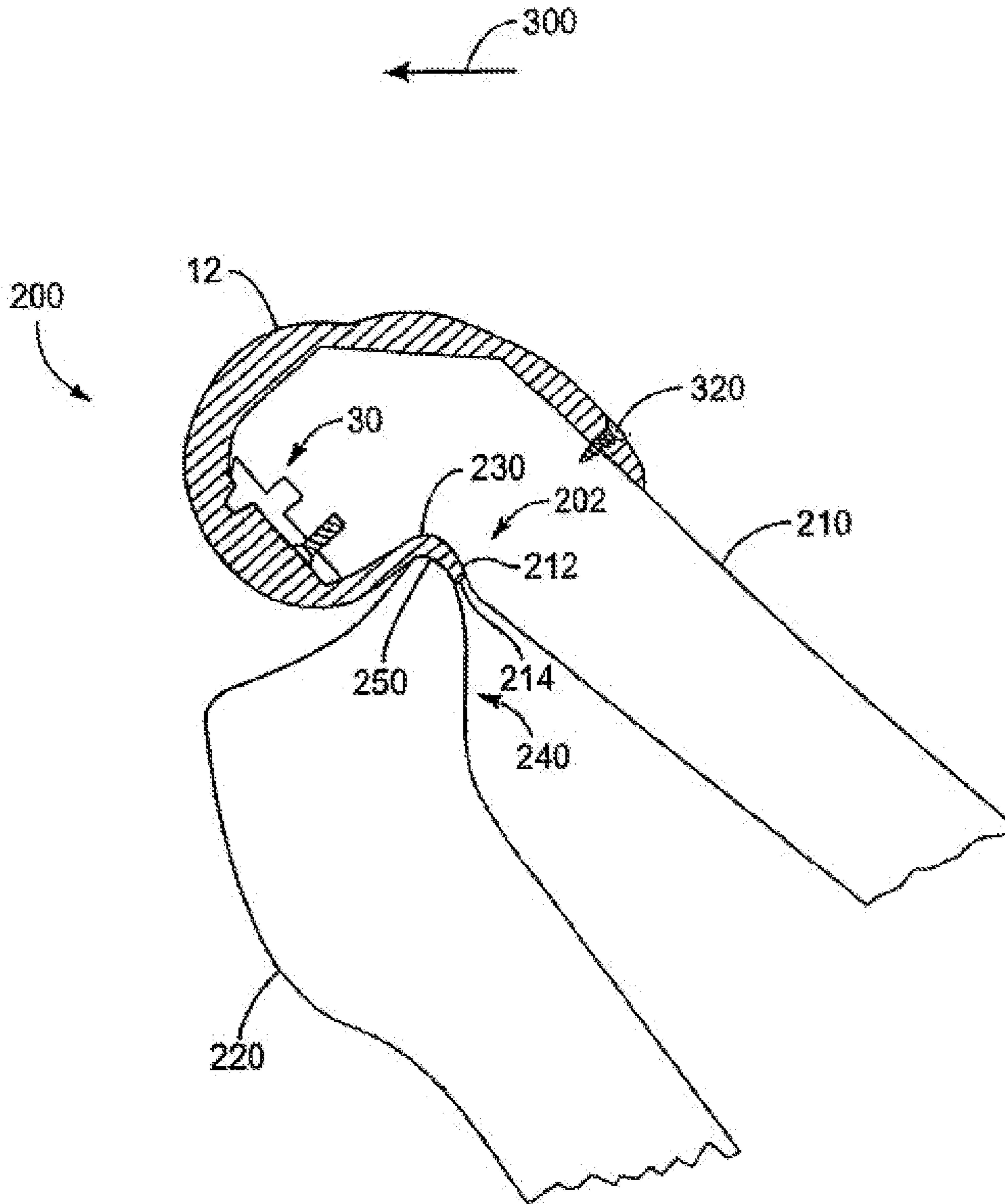

Figure 23

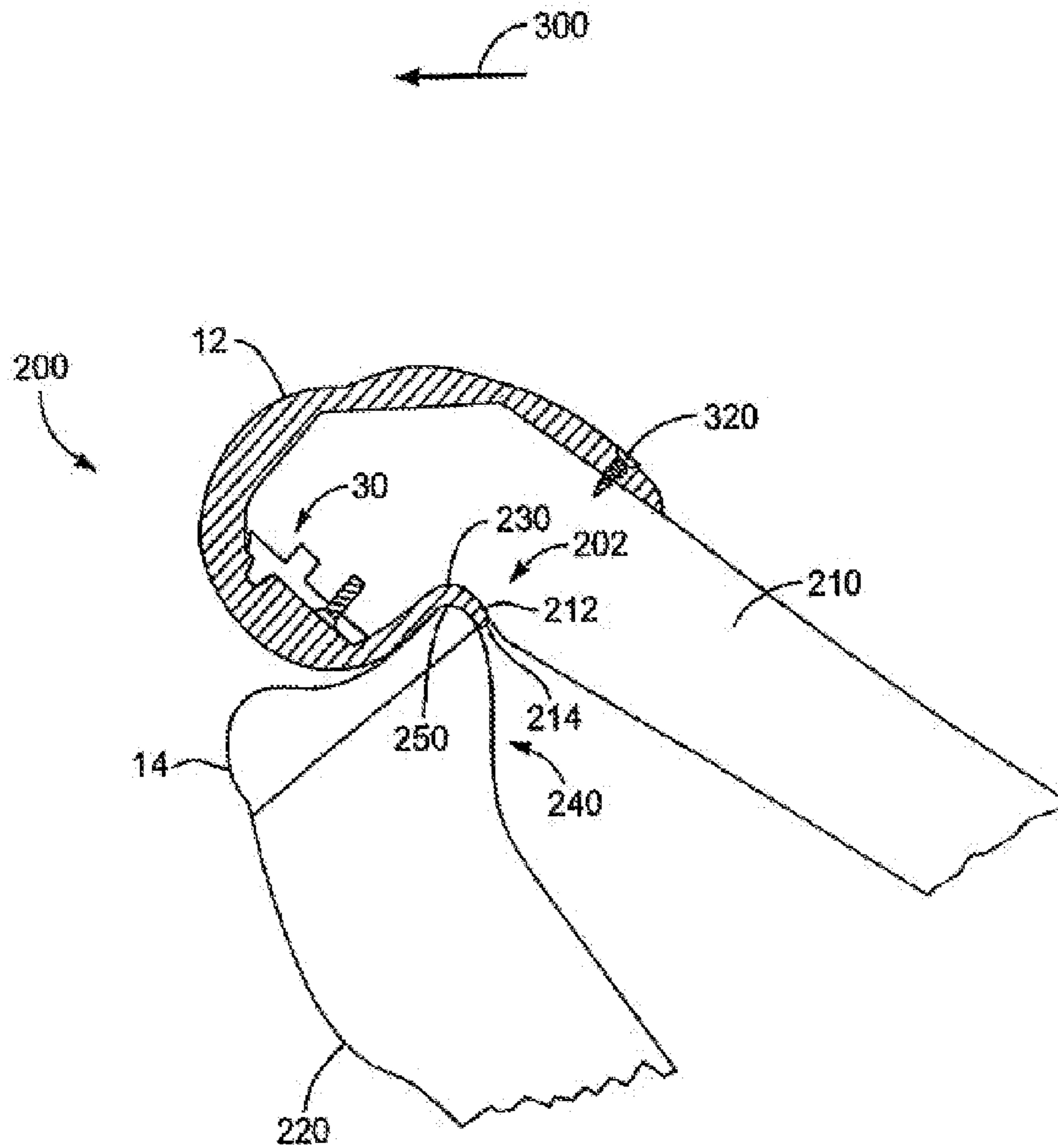

Figure 23A

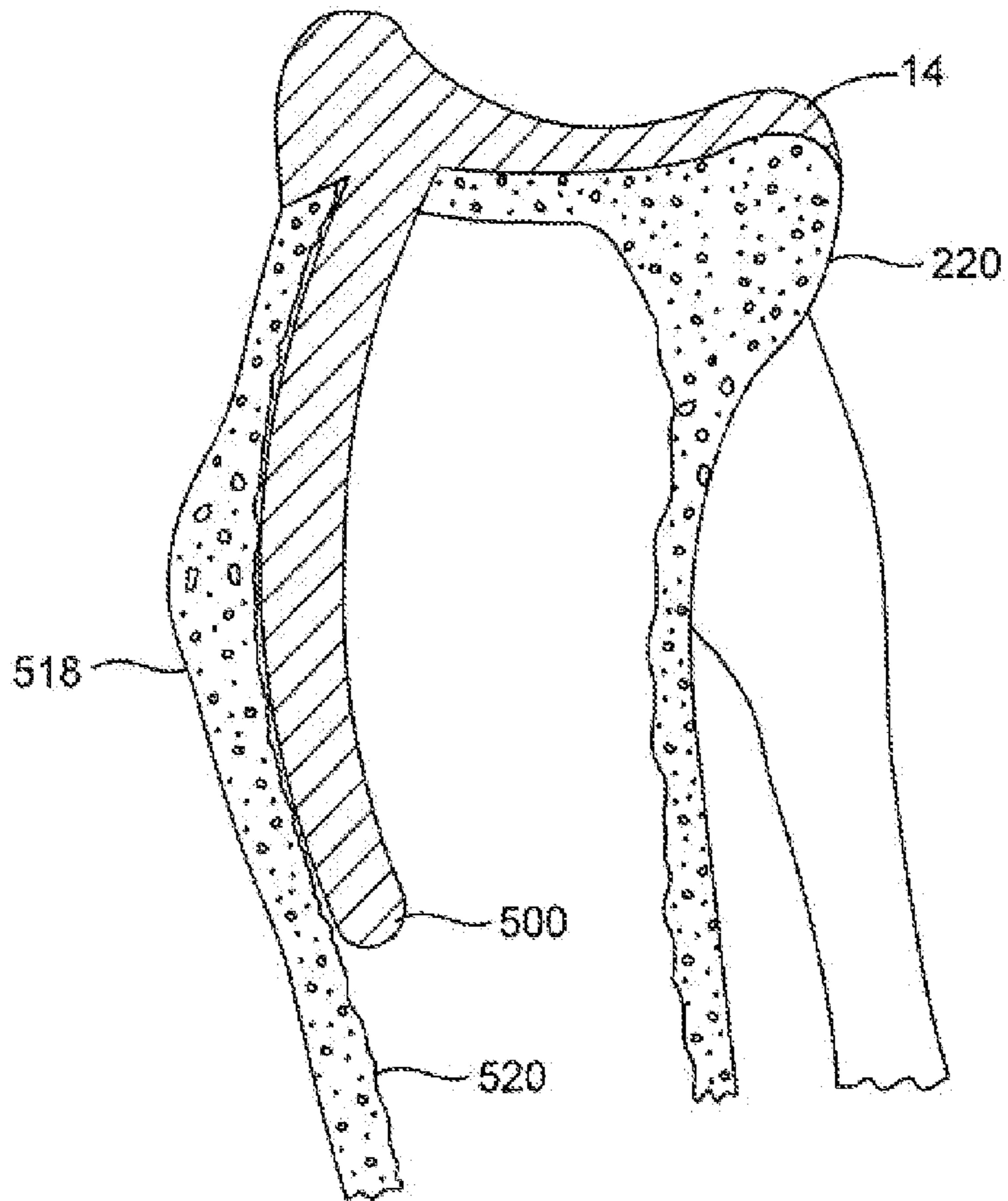

Figure 24

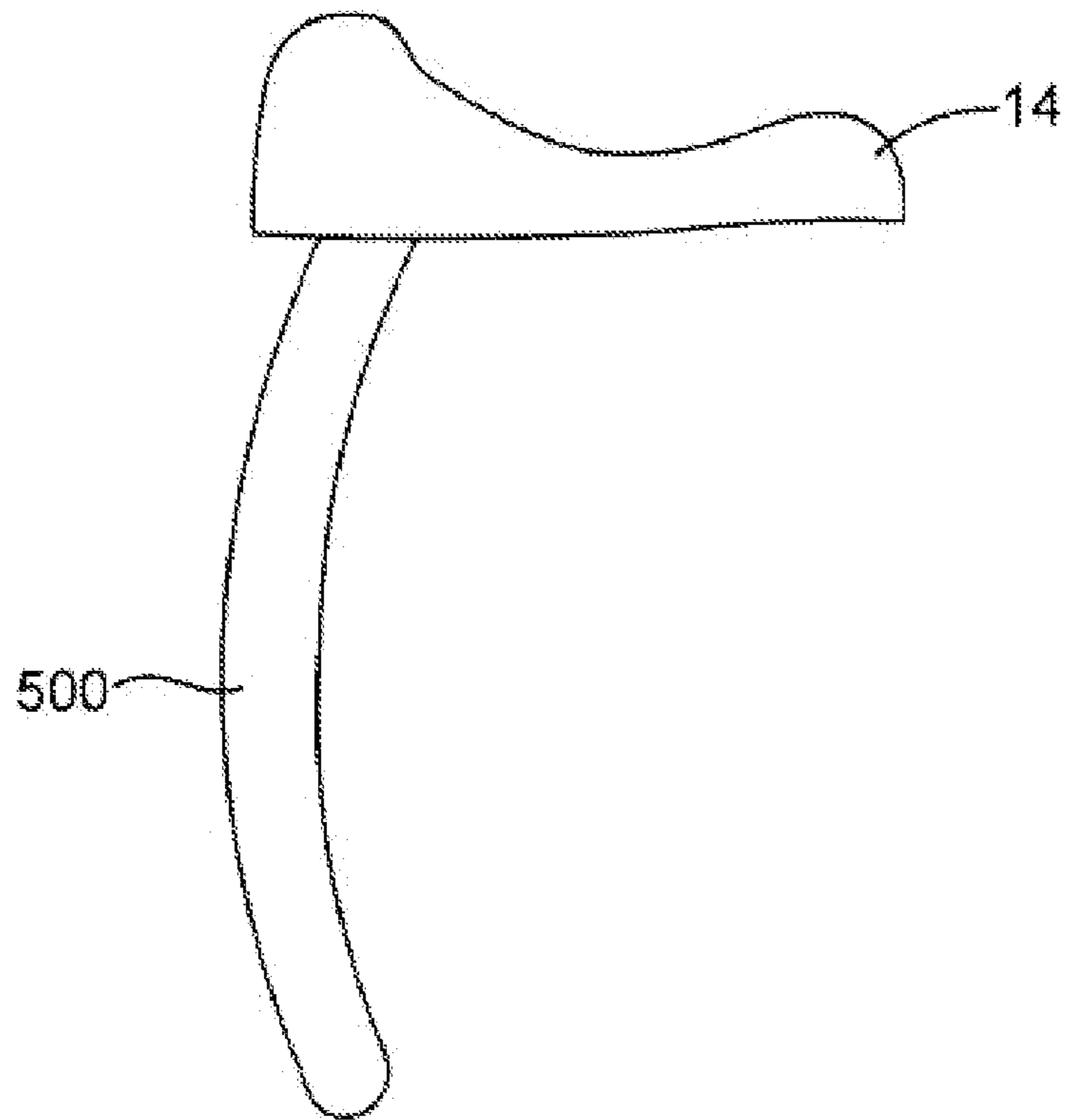

Figure 25

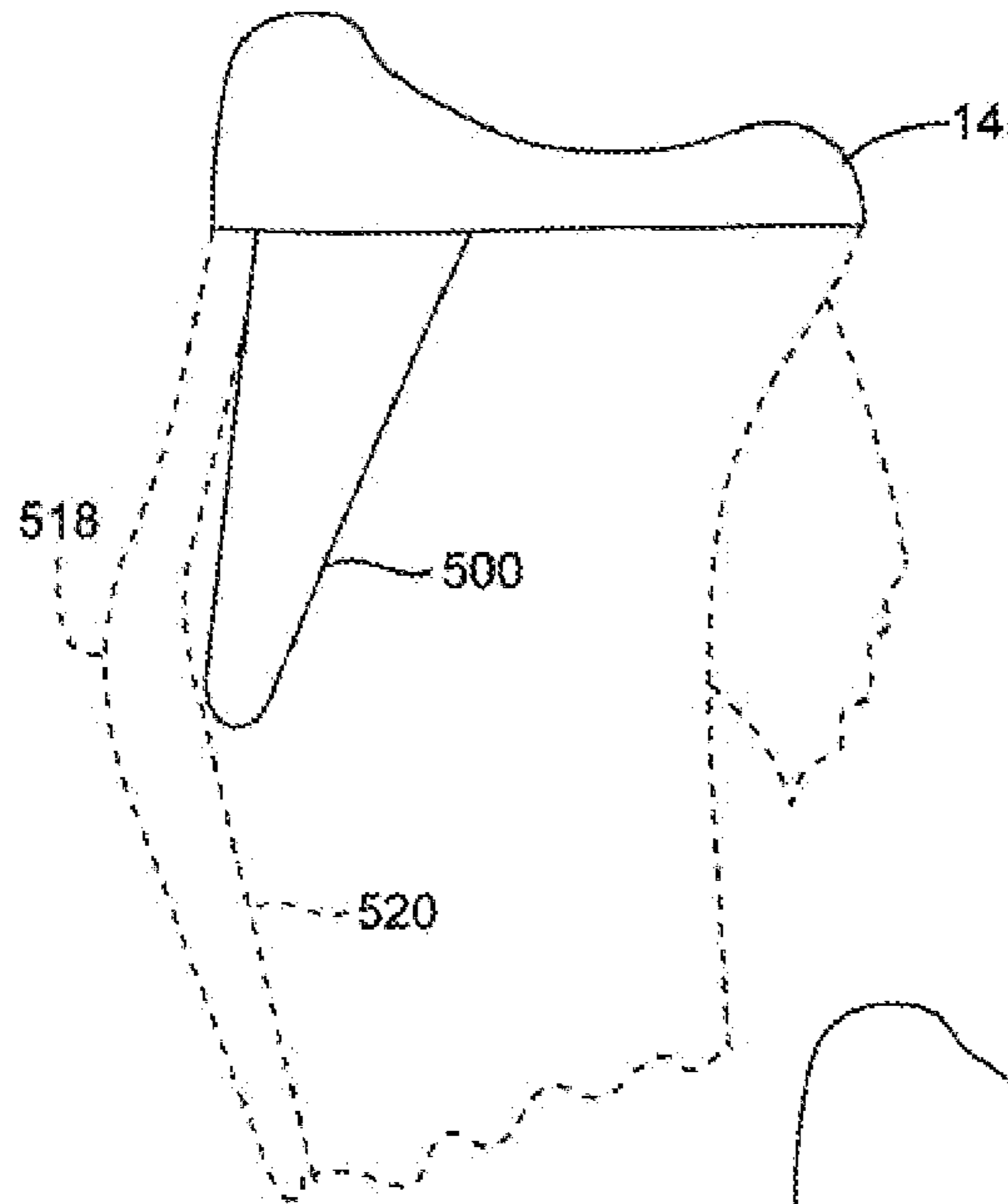

Figure 26

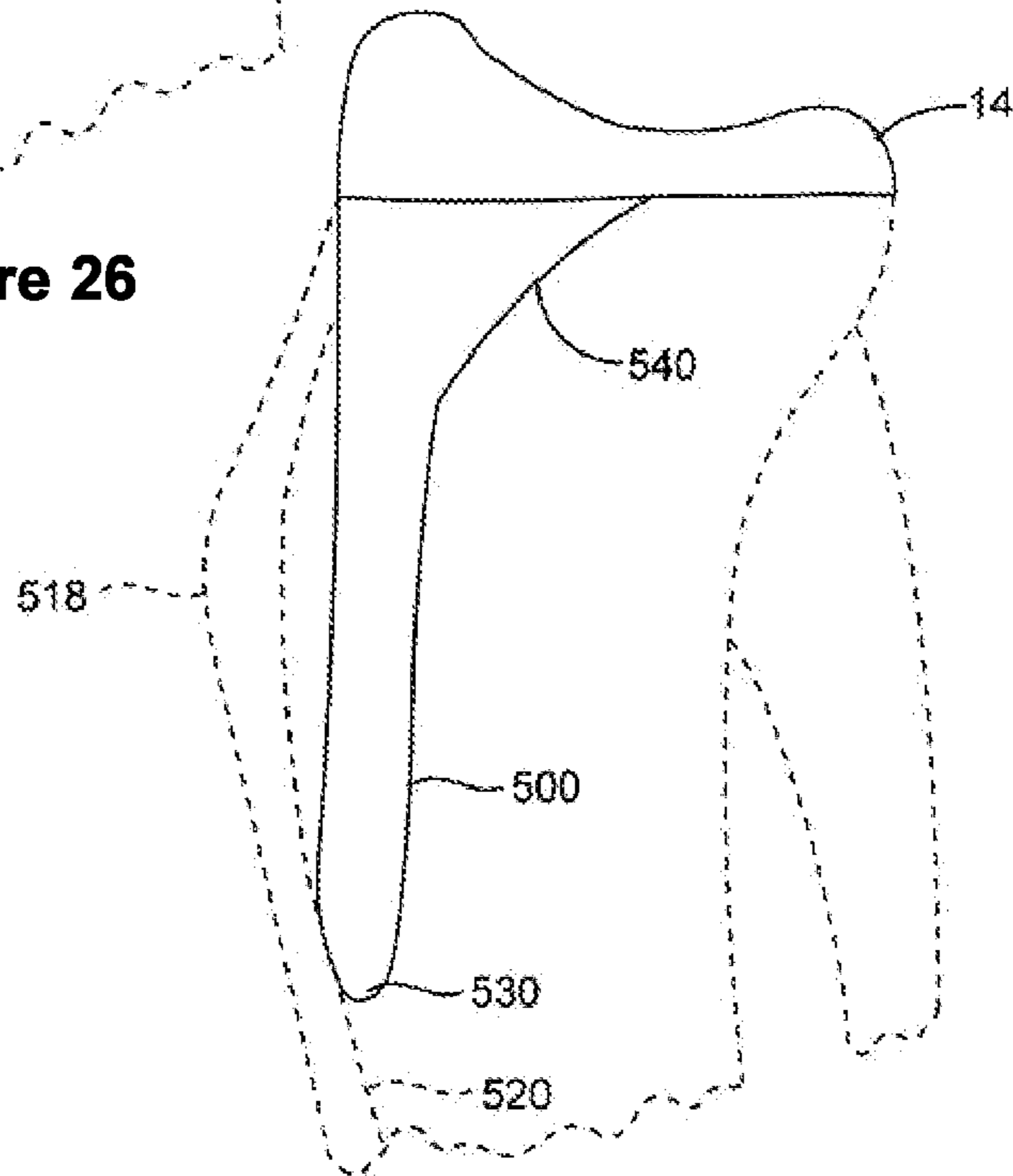

Figure 27

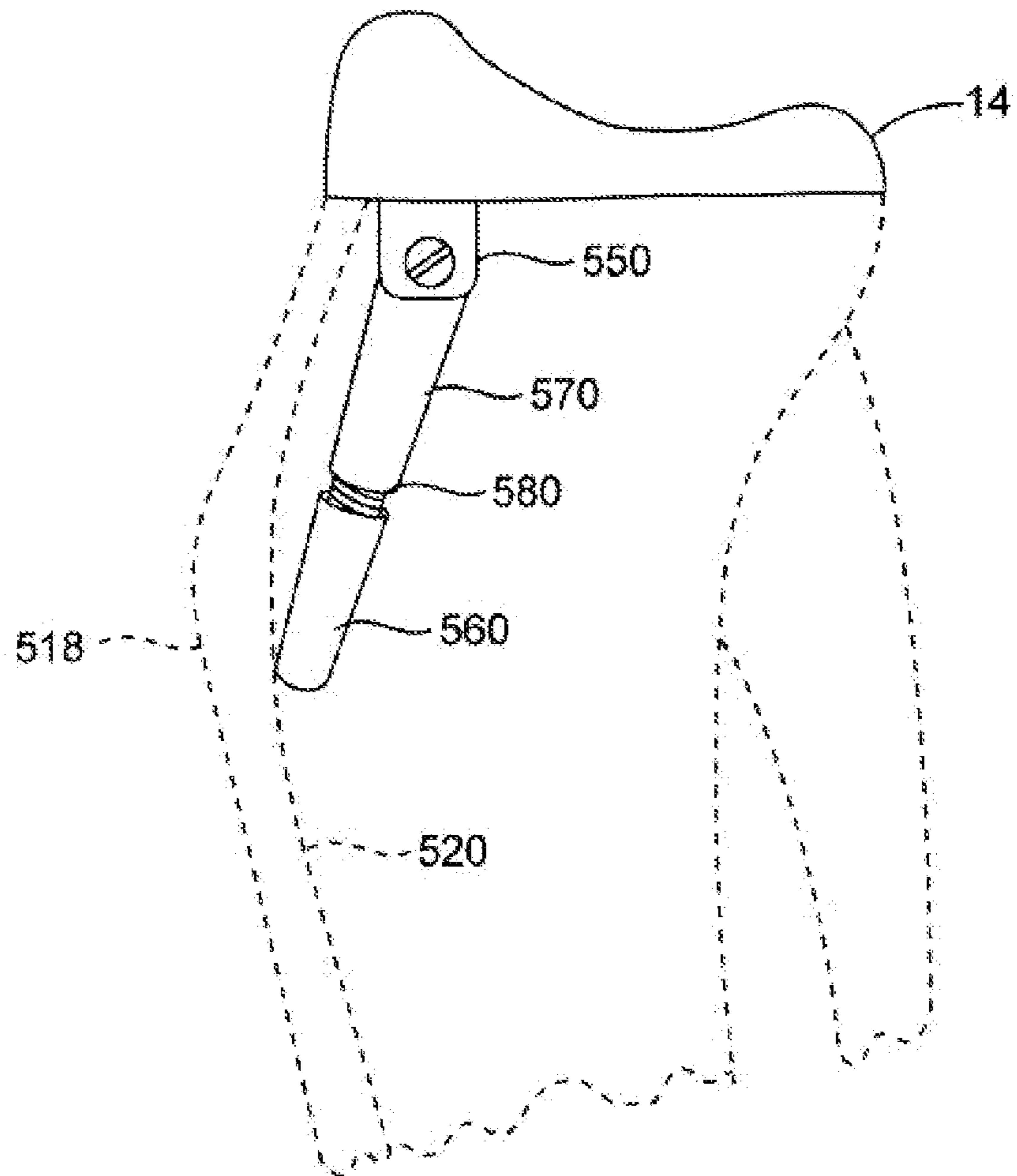

Figure 28

SYSTEMS AND METHODS FOR PROVIDING A STEM ON A TIBIAL COMPONENT

RELATED APPLICATIONS

This is a continuation application of U.S. patent application Ser. No. 13/758,855, filed Feb. 4, 2013, and entitled SYSTEMS AND METHODS FOR PROVIDING A STEM ON A TIBIAL COMPONENT, which is a continuation application of U.S. patent application Ser. No. 12/797,372, filed Jun. 9, 2010, and entitled SYSTEMS AND METHODS FOR PROVIDING DEEPER KNEE FLEXION CAPABILITIES FOR KNEE PROSTHESIS PATIENTS (now U.S. Pat. No. 8,366,783), which is a continuation-in-part of U.S. patent application Ser. No. 12/482,280, filed Jun. 10, 2009, and entitled SYSTEMS AND METHODS FOR PROVIDING DEEPER KNEE FLEXION CAPABILITIES FOR KNEE PROSTHESIS PATIENTS (now U.S. Pat. No. 8,382,846), which is a continuation-in-part of U.S. patent application Ser. No. 12/198,001, filed Aug. 25, 2008, and entitled SYSTEMS AND METHODS FOR PROVIDING DEEPER KNEE FLEXION CAPABILITIES FOR KNEE PROSTHESIS PATIENTS (now U.S. Pat. No. 8,273,133), which claims priority to U.S. Provisional Patent Application Ser. No. 60/968,246, filed Aug. 27, 2007, and entitled SYSTEMS AND METHODS FOR PROVIDING DEEPER KNEE FLEXION CAPABILITIES FOR KNEE PROSTHESIS PATIENTS, and to U.S. Provisional Patent Application Ser. No. 60/972,191, filed Sep. 13, 2007, and entitled SYSTEMS AND METHODS FOR PROVIDING DEEPER KNEE FLEXION CAPABILITIES FOR KNEE PROSTHESIS PATIENTS, each of which is incorporated herein in its entirety by reference.

BACKGROUND OF THE INVENTION

1. Field of the Invention

The present invention relates to knee prostheses. In particular, the present invention relates to systems and methods for providing deeper knee flexion, or full functional flexion capabilities, more physiologic load bearing and improved patellar tracking for knee prosthesis patients. Specifically, these improvements include (i) adding more articular surface to the antero-proximal posterior condyles of a femoral component, including methods to achieve that result, (ii) modifications to the internal geometry of the femoral component and the associated femoral bone cuts with methods of implantation, (iii) asymmetrical tibial components that have an unique articular surface that allows for deeper knee flexion than has previously been available and (iiii) asymmetrical femoral condyles that result in more physiologic loading of the joint and improved patellar tracking.

2. Background and Related Art

Orthopedic surgeons are experiencing a proliferation of knee replacement surgeries. The demand appears driven by the fact that few procedures return as much quality of life as joint replacement.

Moreover, the increased need for knee replacements implicates the need for durable and long lasting artificial knee devices that provide for and allow full, functional flexion. That is, there is a great need for research that provides new medical advances on the overall function and performance of knee prostheses, and improves corresponding surgical materials and technologies related to such devices.

Improvements to knee prostheses correspondingly increase with demand. Thus, currently-available knee pros-

theses mimic characteristics of the normal knee more than those previously used. Unfortunately, today's knee prostheses still have many shortcomings.

Among the shortcomings is the inability of a knee prosthesis patient to achieve deep knee flexion, also known as full functional flexion. Though some currently available knee prostheses allow for knee flexion (i.e., bending) of more than 130 degrees from full limb extension (zero degrees being when the patient's knee is fully extended and straight); such prostheses and results are uncommon. Full functional or deep knee flexion is where the limb is bent to its maximum extent, which may be with the femur and tibia at an angle to each other of 140 degrees or more, though the actual angle varies from person to person and with body habitus. Full extension is where the leg/limb is straight and the person is in a standing position.

To illustrate the average range in degrees achieved by patients having standard knee prostheses, the following is provided. When a patient's knee or limb is fully extended, the femur and tibia are in the same plane at zero degrees, or up to 5-10 degrees of hyperextension in some individuals. However, once the knee bends, and the distal tibia moves toward the buttocks, the angle increases from zero to 90 degrees for a person sitting in a chair. Furthermore, when the tibia is closest to the femur, and the heel is almost at, if not touching, the buttock, the angle is around 160 degrees or more. Most knee prosthesis patients are unable to achieve the latter position or any position placing the knee joint at angles above 130 degrees.

For many people, such a limb and body position is not often achieved or desired most of the time. However, nearly everyone, at some point in time, whether or not it occurs when a person is getting on and off the ground to play with children, or merely incidental to those living active lifestyles, finds themselves in a position requiring knee flexion greater than 130 degrees. Unfortunately, those with currently-available knee prostheses are unable to participate in any activity requiring greater knee flexion and are thus limited to watching from the sidelines.

In many populations and cultures such a limb/knee and body position is desired and necessary the majority of the time. For instance, in Asian and Indian cultures, full functional flexion and the squatting position is common and performed for relatively long periods of time.

A need, therefore, exists for knee prostheses for those patients and especially for those in cultures where extensive squatting, sitting with knees fully flexed, and/or kneeling when praying or eating is common, to achieve knee flexion greater than presently possible among those who have currently-available knee prostheses.

Thus, while techniques currently exist that relate to knee prostheses, challenges still exist. Accordingly, it would be an improvement in the art to augment or even replace current techniques with other techniques.

SUMMARY OF THE INVENTION

The present invention relates to knee prostheses. In particular, the present invention relates to systems and methods for providing deeper knee flexion capabilities for knee prosthesis patients, and more particularly, to: (i) providing a greater articular surface area to the femoral component of a knee prosthesis, with either a modification of, or an attachment to the femoral component of a knee prosthesis, which when integrated with a patient's femur and an appropriate tibial component, results in full functional flexion; (ii) providing modifications to the internal geometry of the

femoral component and the opposing femoral bone with methods of implanting; (iii) providing asymmetrical under surfaces on the tibial component of the knee prosthesis and uniquely-positioned articular surfaces to facilitate full functional flexion; and (iv) asymmetrical femoral condylar surfaces with a lateralized patellar (trochlear) groove to more closely replicate physiologic loading of the knee and to provide better tracking of the patella.

In a normal knee, there is a cessation of active flexion at approximately 120°, first, because the hamstring muscles lose their mechanical advantage, and secondly because the medial femoral condyle rolls posteriorly which does not occur up to 120°. By 120° of flexion, the medial femoral condyle starts to roll backwards relative to the posterior horn of the medial meniscus of the tibia. At 140° of flexion, the femur moves up on to the posterior horn of the medial meniscus. Accordingly, resistance to flexion is felt at this point and beyond. By full flexion, the medial femoral condyle has moved back approximately 8 mm from its position at 120° to a position 10 mm from the posterior tibial cortex. Laterally, the femur moves back an additional 5 mm in hyperflexion so that there is little or no tibiofemoral rotation between 120° and 160°. Accordingly, the hyperflexion between 120° and 160° is a separate arc than the kinematics from 0° to 120° of flexion, and at 160°, the posterior horn of the lateral meniscus comes to lie on the posterior surface of the tibia distal to the femoral condyle. As such, the posterior horn is not compressed and the two bones are in direct contact.

The final limit to hyperflexion arises because the posterior horn of the medial meniscus impedes flexion at 140° and limits it absolutely at 160°. The posterior horn also prevents the medial femoral condyle from moving back beyond a point 10 mm from the posterior tibial cortex. Thus, the posterior horn of the medial meniscus is a key structure in achieving deep flexion.

Implementation of the present invention takes place in association with improved knee prostheses that enable knee prosthesis patients to achieve greater deep knee flexion than previously achievable using presently-designed knee prostheses. In at least some implementations of the present invention, greater deep knee flexion is provided to the knee prosthesis by resecting portions of the femur to allow additional clearance for the posterior horn of the medial meniscus. At least some implementations of the present invention further provide positioning and/or installing an articular surface within resected portions of the femur to provide an interface between the posterior horn of the medial meniscus and the resected surface of the femur.

In at least some implementations of the present invention, greater deep knee flexion is provided to the knee prosthesis by providing an articular surface on the proximal, anterior surface (or portion) of the posterior condyles of the femur. At least some implementations of the present invention embrace an additional or increased articular surface on the proximal, anterior portion of either or both of the medial or lateral posterior condyles of the femoral component of the prosthesis. Embodiments of the femoral component add increased articular surface area to the proximal end of the posterior condyles of the femoral component in an anterior direction such that when the patient bends his or her knee during deep knee flexion, contact between the femoral component and the tibial component is maintained, and a greater, deeper knee flexion can be achieved.

In at least some implementations of the present invention, greater deep knee flexion can be provided or improved by modifying the tibial articulation, in which the center of the

conforming medial tibial articular surface of the tibial component of the prosthesis is moved posterior relative to what is currently available. Additionally, in some such embodiments, the overall shape of the lateral tibial articular surface is modified.

In at least some implementations of the present invention, greater deep knee flexion can be achieved by providing an asymmetrical femoral component of the prosthesis. The asymmetrical femoral component permits transfer of more than one-half of the force transmitted across the joint to be transmitted to the medial side, as occurs in the normal knee. In some implementations, other modifications to the tibial and femoral components of a knee prosthesis may be made, including having asymmetric femoral condyles, having a closing radius on the femoral component, and removing certain areas of the tibial and femoral components; wherein all of the foregoing result in deeper knee flexion capabilities for knee prosthesis patients than previously achievable.

While the methods, modifications and components of the present invention have proven to be particularly useful in the area of knee prostheses, those skilled in the art will appreciate that the methods, modifications and components can be used in a variety of different orthopedic and medical applications.

These and other features and advantages of the present invention will be set forth or will become more fully apparent in the description that follows and in the appended claims. The features and advantages may be realized and obtained by means of the instruments and combinations particularly pointed out in the appended claims. Furthermore, the features and advantages of the invention may be learned by the practice of the invention or will be obvious from the description, as set forth hereinafter.

BRIEF DESCRIPTION OF THE DRAWINGS

In order that the manner in which the above recited and other features and advantages of the present invention are obtained, a more particular description of the invention will be rendered by reference to specific embodiments thereof, which are illustrated in the appended drawings. Understanding that the drawings depict only typical embodiments of the present invention and are not, therefore, to be considered as limiting the scope of the invention, the present invention will be described and explained with additional specificity and detail through the use of the accompanying drawings in which:

FIGS. 1A and 1B depict ranges of flexion of a knee joint;

FIGS. 2A-2C and 3A-3C depict various views of a generic knee prosthesis;

FIGS. 4A-4D depict representative perspective views of embodiments of a femoral component of a knee prosthesis in accordance with embodiments of the present invention;

FIGS. 5A-5D depict representative perspective views of embodiments of a femoral component of a knee prosthesis in accordance with embodiments of the present invention;

FIGS. 6A-6B depict side views of a representative prior art tibial component of a knee prosthesis;

FIGS. 6C-6D depict side views of a representative embodiment of a tibial component in accordance with embodiments of the present invention;

FIGS. 6E-6F depict an alternate embodiment of a representative tibial component modified to include a raised ridge articulation feature.

FIGS. 6G-6H depict an alternate embodiment of a representative tibial component modified to include a spherical articulation feature.

FIGS. 7A and 7B depict alternate embodiments of femoral and tibial components in accordance with embodiments of the present invention;

FIG. 8A illustrates a conventional femoral component while FIG. 8B illustrates an embodiment of a femoral component in accordance with the present invention;

FIG. 9 illustrates a modular attachment for use with embodiments of a femoral component in accordance with embodiments of the present invention;

FIGS. 10A-10H illustrate representative steps for attaching an embodiment of a femoral component to a femur, the resected portions of the femur shown in phantom;

FIGS. 11A-11K illustrate representative steps for attaching an alternate embodiment of a femoral component to a femur;

FIGS. 12A-12B and FIG. 13 illustrate comparisons between a conventional femoral component and an embodiment of a femoral component in accordance with embodiments of the present invention;

FIG. 14 illustrates an alternate embodiment of a femoral component in accordance with embodiments of the present invention;

FIGS. 15A-15D illustrate comparisons between embodiments of a femoral component;

FIGS. 16A-16D illustrate a manner in which an articulating surface of the femoral components shown in FIGS. 15A-15D may be extended;

FIG. 16E illustrates a shortened embodiment in which an articulating surface of the femoral component may be extended;

FIGS. 16F-16P illustrate flexion of a non-limiting embodiment of a femoral component having a decreasing radius, wherein the decreasing radius provides laxity over a portion of the range of flexion in accordance with a representative embodiment of the present invention;

FIG. 16Q illustrates a unicompartmental femoral component including an extended articulating surface in accordance with a representative embodiment of the present invention;

FIG. 16R illustrates a unicompartmental femoral component including a decreasing radius and an indentation in accordance with a representative embodiment of the present invention;

FIG. 16S illustrates a truncated femoral component including an indentation in accordance with a representative embodiment of the present invention;

FIG. 17 illustrates a radiograph of a normal knee flexed to approximately 160 degrees, and further illustrating the position of the patella;

FIGS. 18A through 18C illustrate alternate embodiments of a femoral component in accordance with representative embodiments of the present invention;

FIG. 19A illustrates a tibial component that does not have an articular surface posterior to the main articular surface;

FIG. 19B illustrates the Tibial Full Flex articulation being posterior to the main weight bearing articulation;

FIGS. 20A-20I illustrate a representative interaction of the Femoral Full Flex articulation and the Tibial Full Flex articulation;

FIG. 21 illustrates a representative interaction of the posterior articulate surface of the medial plateau of the tibia and the popliteal surface during deep flexion of the knee;

FIG. 22 illustrates a representative implementation of a resection block and the femur following resection of the popliteal surface;

FIG. 22A illustrates a representative implementation of a resection block and the femur prior to resection of the popliteal surface;

FIG. 23 illustrates a representative interaction of the posterior articulate surface of the medial plateau of the tibia and an extended portion of the femoral component of the knee prosthesis during deep flexion;

FIG. 23A illustrates a representative interaction of the posterior full flex articular surface of the medial tibial plateau of a tibial component and an extended portion of the femoral component of the knee prosthesis during deep flexion;

FIG. 24 illustrates a cross-section view of a tibial component and stem inserted within a tibia in accordance with a representative embodiment of the present invention;

FIGS. 25-27 illustrate various embodiments of stems in accordance with representative embodiments of the present invention; and

FIG. 28 illustrates an adjustable stem in accordance with a representative embodiment of the present invention.

DETAILED DESCRIPTION OF THE INVENTION

The present invention relates to knee prostheses. In particular, the present invention relates to systems and methods for providing deeper knee flexion capabilities for knee prosthesis patients, and more particularly, to: (i) providing an extended articular surface on the proximal, anterior surface (or portion) of the posterior condyles of the femur; (ii) making modifications to the internal geometry of the femoral component and the associated femoral bone cuts with methods of implantation; (iii) making modifications to the tibial and femoral components of a knee prosthesis, including asymmetrical tibial articular surfaces and removing certain areas of the tibial and femoral components; and (iv) having asymmetric femoral condyles, including having a closing radius on the femoral component, wherein all of the foregoing result in deeper knee flexion capabilities for knee prosthesis patients than previously achievable.

It is emphasized that the present invention, as illustrated in the figures and description herein, may be embodied in other forms. Thus, neither the drawings nor the following more detailed description of the various embodiments of the system and method of the present invention limit the scope of the invention. The drawings and detailed description are merely representative of examples of embodiments of the invention; the substantive scope of the present invention is limited only by the appended claims recited to describe the many embodiments. The various embodiments of the invention will best be understood by reference to the drawings, wherein like elements are designated by like alphanumeric character throughout.

With reference now to the accompanying drawings, FIGS. 1A-3C are provided for general reference to assist in understanding the features of the embodiments of the present invention. FIGS. 1A and 1B depict a range of angles possible between the tibia and femur in a person who is extending and flexing (bending) his or her knee. Specifically, FIG. 1A depicts a range of angles possible while the person extends and bends his or her knee, realizing that some knees may flex to 160 degrees, 165 degrees, or beyond. FIG. 1B depicts these various angles in an alternative position. These figures should be kept in mind during the discussion illustrating how with the embodiments of the present invention, knee flexion of greater than 135 degrees is possible for knee

prosthetic patients, which is not generally possible with currently-available knee prostheses.

FIGS. 2A-2C depict various perspective views of a generic knee prosthesis 10. Specifically, FIG. 2A depicts a sagittal view of a left knee joint having a knee joint prosthesis 10, with the tibia and the femur of the normal knee transparent. FIG. 2B depicts an enlarged view of a femoral component 12 of the knee prosthesis 10, while FIG. 2C provides a top perspective view of a tibial component 14 of the knee prosthesis. FIG. 2B depicts certain components of the femoral component 12, such a medial receiving area 16 that may be modified in embodiments of the present invention to integrally connect with an attachment (not shown but hereinafter described) as well as a lateral receiving area 18. The internal geometry of the femoral component 12 is provided to allow a one piece femoral component 12 that is rolled into place on the resected femur 32, as shown in FIG. 4D. Thus, the internal geometry of the femoral component 12 includes various surfaces, including areas 16 and 18, to accommodate the patellar articulation and the anterior extensions of the proximal portions of the posterior condyles. The resected portions of the condyles provide flat surfaces which are loaded in compression in full knee flexion. Additionally, the resected surfaces are provided such that the articular surface of the femoral component is at essentially the same position as the surface being resected. As such, the normal relationship between the femur and the tibia is preserved with full flexion. Additionally, when the knee is fully flexed, the interface between the femoral component and the underlying femur is mainly loaded in compression rather than sheer forces. Compression forces provide a more stable interface between the femoral component and the femur thereby decreasing the chances of loosening. Therefore, in some embodiments the interface between the femoral component and the tibial component are configured to enhance a compression force between the femoral component and the underlying femur during full flexion of the knee joint.

Also visible in FIG. 2B is a medial femoral condylar surface 20 and a lateral femoral condylar surface 22. FIG. 2C depicts the tibial component 14 and its elements: a lateral tibial condylar surface 24, a medial tibial condylar surface 26, and an intercondylar surface 28. When the knee prosthesis 10 is functioning, an interface exists between the medial femoral condylar surface 20 of the femoral component 12 and the medial tibial condylar surface 26 of the tibial component 14 and between the lateral femoral condylar surface 22 of the femoral component 12 and the lateral tibial condylar surface 24 of the tibial component 14.

FIGS. 3A-3C depict additional perspective views of the generic knee prosthesis 10 with its different components. Specifically, FIG. 3A depicts a frontal view of the knee prosthesis 10 with the femoral component 12 articulating with the tibial component 14 as described above. FIG. 3B is a side view of the femoral component 12, and FIG. 3C is a side view of the tibial component 14, and specifically, of the medial side of the tibial component showing the medial tibial condylar surface 26. The medial femoral condylar surface 20 slidingly interfaces with the medial tibial condylar surface 26 so that as a person flexes or extends his or her knee, the arc of the medial femoral condylar surface 20 runs along the medial tibial condylar surface 26.

In some embodiments of the present invention, greater deep knee flexion is provided to the knee prosthesis 10 by providing an articular surface on the proximal, anterior surface (or portion) of the posterior condyles of the femur. At least some embodiments of the present invention

embrace an additional or increased articular surface on the proximal, anterior portion of either or both of the medial or lateral posterior condyles of the femoral component 12. Embodiments of the femoral component 12 add increased articular surface area to the proximal end of the posterior condyles of the femoral component 12 in an anterior direction such that when the patient bends his or her knee during deep knee flexion, contact between the femoral component 12 and the tibial component 14 is maintained, and a greater, deeper knee flexion can be achieved.

Four different examples of how this may be achieved are demonstrated with reference to the Figures. Any method of increasing an articular surface area to the proximal end of the posterior condyles of the femoral component 12 in an anterior direction is embraced by the embodiments of the present invention.

FIGS. 8A and 8B illustrate a femoral component 12 and method of increasing an articular surface area to the proximal end of the posterior condyles of the femoral component 12. FIG. 8A illustrates a side view of a conventional femoral component 12. In the first embodiment of the inventive prosthesis, the shaded area of the femoral component 12 of FIG. 8A, i.e. the posterior condyle, is thickened in the anterior direction until the resulting surface opposing the bone is approaching the same plane as the posterior surface of the shaft of the distal femur. This thickening may be seen with reference to FIG. 8B. This results in a greater articular surface area of the posterior condyles of the femoral component 12. This requires resection of more bone but is otherwise an easy modification to current prostheses and requires little to no modification of current surgical technique.

A second type of embodiment that extends the articular surface area is illustrated by FIGS. 4A-5C. Methods of utilizing this type of embodiment are illustrated with reference to FIGS. 9-10H. This type of embodiment utilizes an extension attachment to the femoral component 12 of an embodiment of the knee prosthesis 10, which when integrated with both the femoral component 12 and a patient's femur, results in a greater surface area of the femoral component 12.

As illustrated in FIGS. 4A-5D, this type of embodiment has a modular attachment 30 that provides a modular flexion attachment surface to extend the articular surface area of the anterior portion of the proximal portion of the posterior condyles. The modular attachment 30 may be attached to the inside, or non-articular surface, of a relatively conventional total knee femoral component 12. The modular attachment 30 has a portion that may be partially received, in one embodiment, within a recessed receiving area on the flat anterior surface of one or both of the posterior condyles of the femoral component 12 and may thus be used on the medial posterior condyle, the lateral posterior condyle, or both. Alternatively, it may be implanted in a groove within either or both of the resected posterior condyles of the femur itself.

The modular attachment 30 provides an increased articular contact area as an anterior continuation of the medial femoral condylar surface 20 and/or of the lateral femoral condylar surface 22 of the femoral component 12. In some embodiments, the modular attachment 30 may be initially placed onto the femoral component 12 and then attached to the distal end of the patient's femur. In other embodiments, the modular attachment 30 may be connected first to the posterior condyles of the distal end of the femur and then integrally connected with the femoral component 12. The

modular attachment 30 may be used on the medial side, on the lateral side or on both sides.

FIGS. 4A-4D depict perspective views of embodiments of the femoral component 12 and the modular attachment 30. As described, the modular attachment 30 attaches to the femoral component 12 and to the femur of a patient to enlarge the surface area of the femoral component 12 and, ultimately, to enable deep knee flexion beyond 140 degrees in a knee prosthesis patient. FIG. 4A depicts a simplified side view of an embodiment of the femoral component 12 having the modular attachment 30 attached to the posterior condyle of the femoral component. FIG. 4D depicts a side view of the attachment integrally attached to a patient's femur and to the femoral component of the knee prosthesis. The modular attachment 30 may be modular as shown in FIGS. 4B-4D and may fit within a recess in either or both of the medial receiving area 16 and the lateral receiving area 18 (i.e. in the anterior interior surface of the posterior condyles of the femoral component 12, as shown in FIG. 2B) and/or in either or both of the medial and the lateral posterior condyles of the femur or in both the femoral component 12 and the femur. In another embodiment the modular attachment 30 may be a permanent part of the femoral component, as discussed below.

FIG. 4B depicts a side view of one embodiment the modular attachment 30 and FIG. 4C depicts a top view of the depicted embodiment of the modular attachment 30. Specific dimensions of the depicted embodiment of the modular attachment 30 are not given and one of skill in the art will recognize that the dimensions may be modified from patient to patient and will also recognize that the various portions of the modular attachment 30 may all be formed in some embodiments to be as wide as the condyle of the femoral component 12.

In some embodiments, the modular attachment 30 includes a first portion roughly perpendicular to a second portion. The first portion of the modular attachment 30 entails a flanged articular area 36 ("flanged area 36") at one end of the modular attachment 30, and an elongated stem 38 extending therefrom, which extends roughly perpendicular from the flanged area, distally from the flanged area 36. The elongated stem 38 therefore is attached to the non-articular side of the flanged area 36. Although the elongated stem is illustrated in FIG. 4C as having a medial-lateral width substantially shorter than the medial-lateral width of the flanged area 36, the elongated stem 38 of other embodiments may be of any medial-lateral width up to the medial-lateral width of the posterior condyles of the femoral component 12 itself.

The elongated stem 38 has an upper side 40 and a lower side 42. Nodules 44 may be placed on either or both of the upper side 40 and the lower side 42, to enable an integral connection with the femur 32 on the upper side 40, and the femoral component 12 on the lower side 42. Some form of a nodule-receiving groove or recess (not shown) may be made in the femur 32 and/or the femoral component 12 to receive these nodules 44 and to secure the integral connection between the femur 32, the attachment 30, and the femoral component 12; with the modular attachment 30 being disposed between the femur 32 and the femoral component 12.

In embodiments having no nodules 44 on the elongated stem 38, the attachment 30 may fit within a recess made on either or both of the medial receiving area 16 and the lateral receiving area 18 of the femoral component 12. The elongated stem 38 of the modular attachment 30 would fit within such recesses and integrally connect thereto. The modular

attachment 30 may simultaneously connect with the femur 32 on the upper side 40 (generally) of the elongated stem 38. In embodiments having no nodules on the elongated stem, the stem of the modular portion may further fit into a groove prepared in the resected posterior condyles of the femur.

The modular attachment 30 increases the overall surface area of the femoral component 12 and prolongs the interface and contact that exists between the femoral component 12 and the tibial component 14. This enables greater knee flexion in prosthetic knee patients because the femoral component 12 remains interfaced with the tibial component 14 throughout the full range of flexion resulting in pain-free knee flexion.

Without this increased surface area, the medial and lateral proximal edges of the posterior femoral condyles of a prosthesis may push into the proximal surfaces of the tibial component 14 and may produce wear of the tibial component 14. In addition, the tibial component 14 may contact the bone of the distal femur 32 that is anterior and/or proximal to the proximal edges of the posterior condyles of the prosthesis and cause pain to and limit flexion of the prosthetic knee patient and may cause wear to the tibial component. Further, without this added surface area, with flexion beyond 140 degrees, the tibial component 14 may exert a force in the distal direction on the femoral component 12, which may result in loosening of the femoral component 12. Therefore, the modular attachment 30 extends the life of the prosthetic knee, decreases pain to the patient, and ultimately, enables a prosthetic knee patient to achieve deep knee or full functional flexion.

FIGS. 5A-5D depict various perspective views of the modular attachment 30 as it is attached to the femoral component 12 and to the femur 32. FIG. 5A is illustrative of the modular attachment 30 as it is attached to the femur 32 prior to attachment of the femoral component 12. FIGS. 5B-5D are illustrative of the modular attachment 30 as it is recessed within the femoral component 12 prior to attachment to the femur 32, and specifically, as the modular attachment 30 is integrally connected to either or both of the medial femoral receiving area 16 and the lateral femoral receiving areas 18.

FIG. 9 and FIGS. 10A-10H illustrate methods of attaching the modular attachment 30 to the femur 32, followed by attaching the femoral component 12 to the femur 32 and modular attachment 30. FIG. 9 illustrates the resection needed on the femur 32 prior to creating the recess in the femur to allow attaching the modular attachment 30. FIG. 9 and FIGS. 10A-10H do not illustrate the specific resection needed for the modular attachment 30, but the resection needed will be appreciated by one of skill in the art. After resection is completed, as at FIG. 10A, the modular attachment 30 may be attached to the femur as at FIG. 10B. The femoral component 12 may then be attached to the femur 32 (and to the modular attachment 30, if desired) by positioning and moving the femoral component 12 as illustrated in FIGS. 10C-10H. As may be appreciated from the sequence of illustrations depicted in FIGS. 10C-10H, the femoral component 12 needs to be rotated or rolled into position, with initial contact beginning in the posterior region as illustrated in FIG. 10E and progressing to the fully-seated position illustrated in FIG. 10G. This is a new implantation technique that will require some additional practice and training over current techniques.

As has been set forth above in reference to FIG. 4A, a third type of embodiment having an extended articular surface is not modular and does not utilize a separate modular attachment 30. In such embodiments, an extended

11

articular surface corresponding to the flanged area **36** of the modular attachment **30** may be integrally formed as part of one or both condyles of the femoral component **12**. Placement of one such embodiment is illustrated with reference to FIGS. **11A-11K**. As may be appreciated with reference to these Figures, placement of such an embodiment also utilizes a similar rotational placement technique to that illustrated in FIGS. **10C-10H**. As may be appreciated by reference to FIGS. **10H** and **11K**, any of the modular or non-modular embodiments may, optionally, be further secured by one or more screws placed in an anterior flange of the femoral component **12**.

One advantage of the embodiment illustrated in FIGS. **11A-11K** is that the implanting surgeon may decide whether to utilize the illustrated embodiment or a traditional femoral component **12** after the distal and anterior oblique cuts have been made. This is illustrated in FIGS. **12A** and **12B**. FIG. **12A** shows a traditional femoral component **12**. FIG. **12B** shows the embodiment of the femoral component **12** illustrated in FIGS. **11A-11K**. As may be appreciated by reference to the Figures, the distal cuts **62** and anterior oblique cuts **64** are essentially identical. This may be further appreciated by reference to FIG. **13**, which shows a superimposed view of FIGS. **12A** and **12B**, not only showing that the distal femoral cuts **62** and the anterior oblique cuts **64** are identical, but also showing that the total amount of bone resected for the illustrated embodiment is similar to or less than the amount resected using current techniques and femoral components **12**.

In a non-modular embodiment of the femoral component **12** as shown in FIGS. **11A-11K** and in a modular embodiment of the femoral component as shown in FIGS. **4A-5D**, there are junctions where the inside flat surfaces of the prosthesis (which when implanted are in contact with the bone) meet. These flat surfaces, rather than coming together at a sharp angle, may or may not have a radius connecting the two flat surfaces. Not all of the junctions of the flat surfaces necessarily need a radius and in some embodiments none of the junctions of flat surfaces will have radii. The flat surfaces may or may not be in exactly the same planes as on conventional knees and will provide for the placement of a non-modular surface that will provide an articulation for the proximal, anterior portion of the posterior femoral condyles extending to or almost to a plane that is a continuation of the posterior cortex of the distal femoral shaft. In embodiments where one or more radii are provided to the junction(s) of the inside flat surfaces of the femoral component **12**, corresponding radii **31** or curvatures may be provided to the resected bone surface of the femur, as is illustrated in FIG. **5A**. As may be appreciated by one of skill in the art, the presence of the corresponding radii **31** may assist in the rotational placement of the femoral component **12** as illustrated in FIGS. **10A-10H** and **11A-11K**.

This internal configuration allows the femoral component **12** to be initially applied to the femur in a flexed position and then rotated into the fully extended position as it is implanted fully, as illustrated and discussed with reference to FIGS. **10A-10H** and **11A-11K**. Screw(s) may, optionally, be placed in the anterior flange of the femoral component **12** to firmly stabilize the component. This ability facilitates implanting the non-modular femoral component **12** or a modular femoral component **12** with the modular attachment **30** already implanted on the posterior condyles of the femur **32**.

A fourth type of embodiment of the femoral component **12** is illustrated in FIG. **14**. This type of embodiment has a femoral component **12** that replaces the weight-bearing

12

distal femoral condyles, in addition to some or all of the articular surface of the posterior condyles extending proximally and anteriorly to an area that is in the same plane as a continuation of the posterior cortex of the distal one fourth to one third of the femur. Such an embodiment may comprise separate medial and lateral components or they may be attached together to form one component that replaces or resurfaces the medial and lateral condyles.

Historically, many early total knee femoral components **12** did nothing regarding the patello-femoral joint. Because a certain percentage of those patients had anterior knee pain, an anterior flange was added to the femoral component **12** to resurface the trochlea (patellar groove). This weakened the patella and resulted in fractures in some patients. Recently techniques have been developed to minimize patellar pain which do not require implantation of a component. The embodiment shown in FIG. **14** does not have an anterior flange that is an integral part on the condylar portion of the prosthesis. It is anticipated that such a device **12** alone may, in some patients, be adequate to replace the femoral condyles and allow the surgeon to treat the patello-femoral joint as he/she felt was indicated. Alternatively, a separate patello-femoral articular surface or surfaces could be implanted. The patello-femoral implant(s) could be entirely separate or could be modular and attached to the device shown in FIG. **14**. The embodiment illustrated in FIG. **14** includes the ability to attach a modular anterior flange (trochlear groove) to the device shown in the Figure.

Implementations of the present invention embrace a femoral component **12**, a tibial component **14** and/or a modular attachment **30** each comprise a metal, metal alloy, ceramic, carbon fiber, glass, polymer (including bone cement), organic material, retrieved human or animal tissue, and naturally occurring or synthetic materials used either separately or in any combination of two or more of the materials.

As may be appreciated by reference to the above discussion and the corresponding Figures, currently-existing femoral components **12** provide an articular surface that only extends a short distance in the proximal anterior direction of the posterior condyle. For example, as may be seen with reference to FIGS. **2A** and **8A**, the articular surface at the anterior end of the posterior condyle typically extends to and replaces at most the posterior third of the posterior condyle, as measured from the most posterior portion of the patient's original posterior condyle (or from the most posterior portion of the femoral component **12**) to a plane that is a continuation of the distal one fourth to one third of the posterior cortex of the femoral shaft.

In contrast, the various embodiments of the femoral component **12** illustrated in the Figures and discussed above provide an extended articular surface for either or both of the medial condyle and the lateral condyle that extends in a proximal anterior direction so as to extend half or more of the anteroposterior distance between the most posterior portion of the posterior condyle and the plane that is a continuation of the distal one fourth to one third of the posterior cortex of the femoral shaft. In some embodiments, the extended articular surface extends at least two-thirds of the anteroposterior distance between the most posterior portion of the posterior condyle and the plane that is a continuation of the distal one fourth to one third of the posterior cortex of the femoral shaft. In other embodiments, the extended articular surface extends nearly the entire anteroposterior distance between the most posterior portion of the posterior condyle and the plane that is a continuation of the distal one fourth to one third of the posterior cortex of

the femoral shaft. In still other embodiments, the extended articular surface may extend even further, to encompass a distal portion of the posterior cortex of the femoral shaft, as illustrated in FIGS. 16A-16D.

The surface of the extension, which may or may not contact bone and is a continuation of the femoral articular surface, can be referred to as the Full Flex Articulation. There may be a corresponding surface on the posterior edge of the medial and or lateral tibial articulation which is not part of the articular surface of the tibia when the tibia is in full extension. For example, in some implementations of the current invention there is a corresponding surface on the posterior edge of the medial tibial articulation where the center of the medial articular surface is more than 20% of the distance from the posterior edge of the component to the anterior edge.

The embodiment illustrated in FIG. 19A shows a non-articular surface 41 posterior to the main articular surface 43. FIG. 19B illustrates a full flex articular surface 45 and an articular surface 47. The Tibial Full Flex articulation of FIG. 19B is posterior to the main weight bearing articulation and articulates with a specific articular area on the femoral component, the Femoral Full Flex articulation (proximal extension 50) shown in FIGS. 16A-16Q and shown in a slightly shortened embodiment in FIG. 16E.

With continued reference to FIG. 16E, in some embodiments of the present invention the full flex articular surface 402 of femoral component 53 comprises sections of various surface radii 404, 406 and 408. Each section is provided as a means for controlling the relationship between the femoral component 53 and the tibial component (not shown) throughout the range of flexion for the knee.

Radius 404 is characterized as having a decreasing radius such that an indentation 410 is formed on the articular surface 402. In some embodiments, indentation 410 is configured to receive anterior ridge 420 of tibial component 14 when the knee joint is hyper extended to approximately -10° , as shown in FIG. 16F. Upon further hyperextension, as shown in FIG. 16G, indentation 410 further impinges upon anterior ridge 420, such that the interface between indentation 410 and anterior ridge 420 acts as a fulcrum between femoral component 53 and tibial component 14. Therefore, as the knee joint is hyper-extended beyond approximately -10° , radius 404 of the articular surface 402 is distracted from the tibial component 14, as shown. As this distraction increases, the dense connective tissues of the knee joint are stressed thereby limiting further hyper-extension of the knee joint.

Referring now to FIG. 16H, a knee joint is shown in a neutral, extended position at approximately 0° flexion. At approximately 0° flexion, radii 404 and 406 are partially in contact with tibial articular surface 403, yet the knee joint is not fully constrained. As such, femoral component 53 is permitted to move anteriorly and posteriorly relative to the tibial component 14. In some embodiments, radii 404 and 406 provide laxity within the knee joint between approximately 0° and 20° flexion. In other embodiments, radii 404 and 406 provide laxity within the knee joint between approximately 0° and 40° flexion.

Referring now to FIG. 16I, a knee joint is shown at approximately 10° flexion, the femoral component 53 being shifted anteriorly relative to tibial component 14. FIG. 16J shows a knee joint at approximately 10° flexion wherein the femoral component 53 has been shifted posteriorly relative to tibial component 14. Anterior and posterior laxity within the knee joint, as provided by radii 404 and 406, is limited both by tension within the dense connective tissues of the

knee joint, and by the curvatures of the opposing femoral and tibial articular surfaces 402 and 403. By providing laxity between approximately 0° and approximately 20° the natural mechanics of knee flexion are preserved, as sensed or experienced by the user. In some embodiments, laxity is eliminated between approximately 0° and approximately 20° , thereby modifying the natural mechanics of knee flexion as may be desired.

Upon further flexion of the knee joint to approximately 20° , radius 406 is largely in contact with tibial articular surface 403, as shown in FIG. 16K. However, in some embodiments laxity within the knee joint is maintained at approximately 20° flexion such that the femoral component 53 is permitted to shift anteriorly (FIG. 16K) and posteriorly (FIG. 16L) relative to the tibial component 14. As the knee joint is further flexed, radius 406 assumes full contact with the opposing tibial articular surface 403 thereby fully constraining anterior and posterior movement within the knee joint, as shown in FIG. 16M. Full contact and constraint within the knee joint is thereafter maintained through the remaining mid-flexion movement of the joint, as shown in FIGS. 16N and 16O. Beyond approximately 110° flexion, radius 408 begins to pick up contact with tibial articular surface 403 thereby causing distraction of the femoral and tibial components 53 and 14, as shown in FIG. 16P. As the knee joint is further distracted, proximal extension 50 maintains contact with posterior articular feature 412 of the tibial component 14.

With reference to FIG. 16Q, a representative embodiment of a unicompartmental femoral component 120 is shown. The various components of the present invention may be substituted with a unicompartmental component, as discussed below. In some embodiments, unicompartmental femoral component 120 further comprises a decreasing radius 404 providing indentation 410, as shown in FIG. 16R. In other embodiments, unicompartmental femoral component 120 is truncated thereby providing indentation 410 at intersection between component 120 and non-resected anterior condylar surface of femur 32, as shown in FIG. 16S.

The unicompartmental component is generally implanted to replace the weight bearing portion of the knee joint medially or laterally. The unicompartmental component may be used medially and/or laterally as two separate femoral and two separate tibial components on just the weight bearing portion of the joint. In some embodiments, the unicompartmental component is used with two femoral or two tibial components joined, but ignoring the patello-femoral joint. In other embodiments, the unicompartmental component is used as one femoral component replacing the medial and lateral weight bearing portions of the distal femur and also a portion of, or all of the patello-femoral joint with either a one piece tibial component or separate medial and lateral tibial components. Finally, in some embodiments the unicompartmental component is a one-piece, femoral component replacing the patello-femoral joint and either the medial or lateral weight-bearing portion of the femur. In some embodiments, the unicompartmental component 120 includes a Full Flex Femoral articulation surface 50. As previously discussed, the articulation surface or extension 50 is configured to provide extended contact between the unicompartmental femoral component 120 and a Full Flex Tibial articulation surface 55 of a tibial component during deep flexion of the knee. In some embodiments, a portion of the popliteal surface 202 of the femur is removed to accept placement of the articulation surface 50. In other embodiments, a unicompartmental component (not shown) is provided for use in conjunction with a modular Full Flex

Femoral articulation surface (not shown). Thus, in some embodiments a first portion of the femur is prepared to receive the unicompartamental component **120**, and a second portion of the femur is prepared to receive a modular Full Flex Femoral articulation surface (not shown). As such, a combination of the unicompartamental component and the modular Full Flex Femoral articulation surface provide a unicompartamental femoral component that is functionally equivalent to the unicompartamental femoral component **120**.

In some embodiments, the unicompartamental femoral component **120** is used in conjunction with a unicompartamental tibial component. In other embodiments, the unicompartamental femoral component **120** is used in conjunction with a full tibial component. Finally, in some embodiments, the unicompartamental femoral component **120** is used directly in conjunction with a natural surface of the opposing tibia.

Where permitted, implementation of a unicompartamental femoral component **120** provides several advantages over total knee replacement procedures. For example, while an eight-inch incision is typically required for a total knee replacement surgery, a partial knee replacement utilizing a unicompartamental femoral component **120** requires an incision of approximately three-inches. Thus, one benefit of a unicompartamental femoral component **120** is decreased scarring following the partial knee replacement procedure.

Other benefits of a partial knee replacement include decreased recovery time, increase range of motion, and decreased overall damage to the knee. A total knee replacement procedure may require the patient to remain in the hospital for up to four days. It can also take up to three months, or longer, to recover from the surgery. However, with a partial knee replacement procedure, a patient typically requires no more than two days of hospitalization followed by one month of recovery. Additionally, a patient is typically able to walk without assistance a week or two following the partial knee replacement procedure.

Unlike some total knee replacement procedures, insertion of the unicompartamental femoral component **120** generally preserves more ligaments thereby providing a fuller range of motion. For example, in some partial knee replacement procedures, the anterior and/or posterior cruciate ligaments are preserved, as desired. A partial knee replacement also generally results in less damage to the knee because the surgery is minimally invasive thereby causing minimal tissue, muscle and tendon damage to the knee.

For some partial knee replacement procedures, various methods may be implemented to address pain and discomfort caused by patello-femoral arthritis. For example, for some partial knee replacement procedures denervation of the patella is performed. In other partial knee replacement procedures, denervation of the opposing femoral groove is performed. In some embodiments of the present invention the unicompartamental femoral component **120** is designed to reproduce the natural patello-femoral joint throughout the range of motion and to facilitate tracking of the patella in the femoral groove. In other embodiments, a combination of denervation and natural design of the unicompartamental femoral component **120** are implemented to adequately address the patello-femoral arthritis.

The interaction of the Femoral Full Flex articulation **50** and the Tibial Full Flex articulation **55** is illustrated in FIGS. **20A-20I**, wherein FIGS. **20A-20E** are at 0 degrees, FIG. **20F** is at 90 degrees, FIG. **20G** is at 130 degrees, FIG. **20H** is at 150 degrees, and FIG. **20I** is at 160+ degrees. FIG. **20B** identifies a representative position of unresected tibial plateau **51**. FIG. **20C** identifies a representative closing radius

on a posterior portion of a femoral component **53**. FIG. **20D** identifies a representative Full Flex Femoral articulation **50**. FIG. **20E** identifies a representative Full Flex Tibial articulation **55**. FIG. **20H** identifies a representative approach of the Full Flex Femoral articulation **50** to the Full Flex Tibial articulation **55** during flexion. FIG. **20I** identifies a representative contact of the Full Flex Femoral articulation **50** to the Full Flex Tibial articulation **55** during deep flexion.

FIGS. **15A-15D** illustrate the various manners in which the four previously-discussed embodiments of the femoral component **12** provide an extended articular surface **48**. The concept of adding more articular surface to the proximal portion of the posterior condyles of the femoral component may be generally accomplished by extending the proximal portion anteriorly until the articular surface approaches, or extends beyond the plane of the posterior surface of the shaft of the distal femur, if that plane were to extend distally. For example, as may be seen from FIGS. **15A-15D**, the extended articular surface **48** of each embodiment extends the articular surface at the anterior end of one or both of the medial posterior condyle or the lateral posterior condyle. As illustrated in FIGS. **16A-16D**, the articular surface may be further extended in a proximal direction from the end of the extended articular surface **48**. This further extension may be provided by a proximal extension **50**. The proximal extension **50** may be an integral part of the femoral component **12**, it may be a part of the modular attachment **30**, or it may be provided as a separate and additional component. In one embodiment where the proximal extension **50** is provided, the proximal extension **50** acts as a fulcrum that interacts with the tibia or with the tibial component **14** to increase separation between the femur **32** and the tibia during full functional flexion to improve the deep knee flexion. In another embodiment, the proximal extension **50** allows the normal relationships between the tibia and femur in full functional flexion to exist while maintaining contact between the two surfaces.

Thus, in some embodiments of the present invention, greater deep knee flexion is facilitated by providing an articular surface on the proximal, anterior surface (or portion) of the posterior condyles of the femur. At least some such embodiments embrace an additional or increased articular surface on the proximal, anterior portion of either or both of the medial or lateral posterior condyles of the femoral component **12**. Embodiments of the femoral component **12** add increased articular surface area to the proximal end of the posterior condyles of the femoral component **12** in an anterior direction such that when the patient bends his or her knee during deep knee or full functional flexion, contact between the femoral component **12** and the tibial component **14** is maintained, and a greater, deeper knee flexion may be achieved.

In at least some embodiments of the present invention, greater deep knee flexion may be provided or improved by modifying the tibial articulation, in which the center of the conforming medial tibial articular surface of the tibial component **14** is moved posterior relative to what is currently available. Additionally, in some such embodiments, the overall shape of the lateral tibial articular surface may be modified. This is illustrated with reference to FIGS. **6A-6D**.

In such embodiments of the tibial component **14**, the condylar or articular plateau surfaces may be asymmetric. That is, the lateral undersurface side of the tibial component **14** is shorter in the anteroposterior dimension than the medial side, and the top of the tibial component **14** may also be asymmetric.

Anatomically the tibial plateau has a greater anteroposterior dimension medially than it has laterally. In order to cover as much of the cut proximal tibia as possible and avoid anterior or posterior overhang of the lateral plateau, it is necessary to have a component that is larger in the anteroposterior dimension medially than it is laterally. In one embodiment, this is accomplished by moving the center of the medial articular surface posteriorly to compensate for the dimensional differences. In order to achieve full flexion, it is important to have the medial center of rotation on the tibia (which is a concave segment of a sphere) more posterior than is currently available with other designs. This allows the proximal tibia, when the knee is flexed beyond approximately 120-130 degrees, to be positioned anteriorly enough so that there is no impingement of the posterior edge or portion of the medial tibial articular surface on the proximal portion of the posterior medial condyle of the femur. Current designs of tibial components **14**, which will allow the tibia to move anterior with flexion, either have a non-spherical medial tibial articular surface or the center of rotation of the spherical articular surface is not as far posterior as is provided by the embodiments described below. However, embodiments of the current invention may be used in combination with any knee replacement design that will allow knee flexion to 120° or greater.

Currently-available total knee tibial components **14** that have a fixed center of rotation medially have the center of rotation located at a position that is around 35-45% of the entire anteroposterior dimension from the posterior surface of the tibial component **14**. In some embodiments of the tibial component **14**, the center of rotation is moved posteriorly so that it is between 18-30% of the anteroposterior dimension from the posterior wall of the tibial component **14**.

In the normal knee the medial side of the knee is constrained in that for any degree of flexion the position of the medial femoral condyle relative to the tibial articular surface is roughly fixed and does not move anteriorly or posteriorly a significant amount in the flexion range of roughly 20-140 degrees. In contrast, on the lateral side, except for full extension and sometimes full flexion, after around 20-40 degrees of flexion the lateral femoral condyle can move anterior and posterior on the lateral tibial plateau. In full functional flexion to 160 degrees and beyond, the lateral femoral condyle may appear to be touching only the most posterior portion of the opposing tibial plateau or it may contact the plateau more anterior clearly on the flattened portion of the lateral tibial plateau.

Therefore, in embodiments of the tibial component **14**, the lateral tibial articular surface is basically flat in the anteroposterior sense, except anteriorly where there is an anterior lip which prevents the tibial component from rotating too far externally and allowing the lateral femoral condyle to slide off the anterior edge of the tibial component. In some embodiments, the basically flat portion of the lateral tibial articular surface may comprise between two-thirds and seven-eighths of the total anteroposterior dimension of the tibial component **14**. In some embodiments, a slight lip may be present posteriorly on the lateral side, however, as long as the fixed center of rotation is positioned as described, no lip is required posteriorly on the lateral side. The lateral tibial articular surface is either flat or concave when viewed in the frontal plane and, if concave, may or may not be the same radius of curvature of the opposing femoral condyle or it may have a greater radius when viewed in the frontal plane. This flat or concave groove is flat on the bottom when viewed in the sagittal plane, except for the anterior and

posterior ends as noted above and is generated around a point that corresponds to the center of rotation of the medial condyle. In some embodiments, the posterolateral tibial articulation may be the same as described for the medial posterior full flex articulation. In other embodiments, the medial tibial articular surface may be the same as, or similar to the flat articular surface described for the lateral tibial plateau. However, the position of the medial articular contact is mainly obligatory while the position of the lateral articular contact is non-obligatory. Thus, the position of the lateral articular contact is likely determined by the task being performed, by comfort, or by culture.

One having skill in the art will appreciate that the knee may include at least one of a lateral pivot and a medial pivot. Accordingly, the embodiments of the present invention will be understood to be compatible with either or both of the lateral and medial knee pivot configurations.

FIGS. **6A-6D** depict a comparison of a prior art tibial component **14**'s medial tibial condylar surface **26** and lateral tibial condylar surface **24** with an embodiment of the tibial component **14** as discussed above. Specifically, FIGS. **6A** and **6B** reflect side views of medial and lateral sides of some currently available tibial components **14**, respectively, while FIGS. **6C** and **6D** illustrate side views of medial and lateral sides of an embodiment of the tibial component **14** as discussed above. It will be appreciated that a number of varied configurations for the medial and lateral articular surfaces ranging from almost flat, both medially and laterally, to more conforming, as shown in FIGS. **6A** and **6B**, have been used in the past; however, there are none that have either a combination of a posteriorly-displaced medial articular surface and a relatively-flat lateral articular surface, or a medial femoral full flex tibial articulation. These configurations permit the lateral femoral condyle to move anteriorly and posteriorly as the knee flexes and extends. Other configurations may be provided, so that as long as the lateral tibial articular surface will allow this anteroposterior motion, the lateral tibial configuration does not need to be specifically as shown in FIG. **6D**.

The lateral tibial articulation may in some embodiments have no posterior lip, and in other embodiments the posterior surface may slope downward when it is accompanied by a medial tibial articulation that provides for flexion beyond 135 degrees.

In the prior art tibial component **14**, the condylar surface has a curvature centered on a fixed point **52**. The distance from the fixed point **52** (or from the low point of the curvature centered on the fixed point **52**) to the posterior edge **54** of the tibial component is approximately 35-45% of the anteroposterior dimension of the tibial component **14**. These measurements are similar for the medial (FIG. **6A**) and lateral (FIG. **6B**) sides of the tibial component **14**. Currently available tibial components **14** have a lip **56**.

In the embodiment of the tibial component **14** illustrated in FIGS. **6C** and **6D**, there is no tibial component lip **56**. Rather, the medial tibial condylar surface **26** runs along a smooth arc. As the arc is generated, a low lip may be present in some embodiments and may extend up to and include the femoral full flex posterior articulation. The amount of the lip will be determined by the relationship of the center of rotation to the posterior edge **54** of the tibial component **14**. Though the radius from fixed point **52** to the articular surface in FIGS. **6A** and **6C** is the same, the distance from the fixed point **52** (or from the low point of the curvature centered on the fixed point **52**) to the posterior edge **54** of the tibial component **56** is shorter, at approximately 18-30% of the anteroposterior dimension from the posterior end of the

tibial component **14**, as may be seen in FIG. **6C**. With respect to the lateral side of the tibial component **14**, in the embodiment illustrated in FIG. **6D**, there is both an anterior lip **58** and a small posterior lip **60**. In alternate embodiments, the posterior lip **60** may be omitted as discussed above.

Thus, as has been illustrated with reference to FIGS. **6A-6D**, in at least some embodiments of the present invention, greater deep knee flexion may be provided or improved by modifying the tibial articulation, in which the center of the conforming medial tibial articular surface of the tibial component **14** is moved posterior relative to what is currently available. This change alone, with some currently-available femoral components, will increase the amount of flexion achieved when compared to a standard tibial component. Additionally, in some such embodiments, the overall shape of the lateral tibial articular surface may be modified. This allows the proximal tibia, when the knee is flexed beyond approximately 120-130 degrees, to be positioned anteriorly enough so that there is no impingement of the posterior edge or portion of the medial tibial articular surface on the proximal portion of the medial condyle of the femur. Therefore, greater deep knee flexion may be achieved. It can thus be appreciated that the use of an embodiment of the above tibial component with a conventional femoral component will facilitate greater flexion than will the use of a conventional tibial component. Similarly, the use of any of the above-described femoral components with a conventional tibial component will facilitate more flexion than will use of a conventional tibial component with a standard femoral component.

In some embodiments of the present invention, greater deep knee flexion may be provided or improved by modifying tibial articulation, in which the articulated surface of the tibial component is modified to encourage or limit articulation of the femoral component relative to the tibial component. Examples of such modification are shown in FIGS. **6E-6H**.

Referring now to FIGS. **6E** and **6F**, a tibial component **14** is shown in accordance with a representative embodiment of the present invention. In some embodiments, the medial tibial condylar surface **26** of the tibial component **14** is modified to include an articulation feature. An articulation feature is generally provided to compatibly interact with an opposing articulation surface of the femoral component. During flexion of the knee the articulation surface of the femoral component interacts with the articulation feature of the medial tibial condylar surface to guide or direct the articular movement of the femoral component relative to the tibial component. Thus, in some embodiments an articulation feature is provided to control articulation of the knee during deep flexion.

Various types of articulation features may be used in accordance with the teaching of the present invention. For example, in some embodiments an articulation feature comprises an angled articular ridge **400**. The articular ridge **400** is provided to compatibly interact with an opposing articular surface of the femoral component. The interaction between the articular ridge **400** and the articular surface of the femoral component effects a change in the articular movement of the femoral component during deep flexion of the knee. For example, in some embodiments an interaction between the femoral component and the articular ridge **400** causes the posterior articulation of femoral component to shift when deep flexion is achieved.

The articular ridge **400** is generally disposed on the posterior surface of the tibial component **14** in a general medial-lateral direction **450**. In some embodiments, the

articular ridge **400** is disposed or positioned on the posterior surface at an angle θ that is acute to an anteroposterior direction **460** of the intercondylar surface **28**. Generally, angle θ of the articular ridge **400** is selected so as to achieve a desired articular shift of the femoral component during deep flexion. In some embodiments, an angle θ of approximately 0° to approximately 90° is selected. In other embodiments, an angle θ of approximately 10° to approximately 45° is selected. Finally, in some embodiments, an angle θ of approximately 20° to approximately 35° is preferred.

The articular ridge **400** may be positioned anywhere on the articular surface of the tibial component so as to achieve a desired articular shift of the femoral component during deep flexion of the knee. For example, in some embodiments the lateral tibial condylar surface **24** is modified to include the articular ridge (not shown). In other embodiments, both the medial and lateral tibial condylar surfaces **26** and **24** include an angled articular ridge **400**. In some embodiments, the articulation feature comprises a polyethylene coating or layer. In other embodiments, the polyethylene coating is strictly applied to the articular ridge **400** and precluded from extending beyond articular ridge **400** so as to impinge on the femur during flexion.

Referring now to FIGS. **6G** and **6H**, a tibial component **14** is shown in accordance with a representative embodiment of the present invention. In some embodiments, the medial tibial condylar surface **26** of the tibial component **14** is further modified to include an articulation feature comprising a spherical articular surface **420**. The spherical articular surface **420** is provided to compatibly interact with an opposing articular surface of the femoral component. The interaction between the spherical articular surface **420** and the articular surface of the femoral component enable unrestricted, natural articular movement of the femoral component during deep flexion of the knee. For example, in some embodiments an interaction between the femoral component and the spherical articular surface **420** permits a natural posterior articulation of the femoral component when deep flexion is achieved. One of ordinary skill in the art will appreciate that the tibial component **14** may also be modified to permit femoral articulation on the lateral tibial condylar surface of the tibial component. Additionally, one of ordinary skill in the art will appreciate that the tibial component **14** may be modified to permit concomitant femoral articulation on both the medial and lateral tibial condylar surfaces of the tibial component, for desired applications.

The spherical articular surface **420** may comprise a true spherical shape, or may comprise a parabolic shape. One of skill in the art will appreciate that variations in the surface structure of the articular surface **420** may be required to provide an articular surface that is optimally configured for a specific application or use.

The spherical articular surface **420** may be positioned anywhere on the articular surface of the tibial component so as to achieve a desired natural movement to the femoral component during deep flexion of the knee. For example, in some embodiments the lateral tibial condylar surface **24** is modified to include the spherical articular surface (not shown). In other embodiments, both the medial and lateral tibial condylar surfaces **26** and **24** include a spherical articular surface **420**. In some embodiments, the articulation feature comprises a polyethylene coating or layer. In other embodiments, the polyethylene coating is strictly applied to the spherical articular surface **420** and precluded from extending beyond spherical articular surface **420** so as to impinge on the femur during flexion.

In some embodiments, the opposing surface of the femur and/or femoral component is modified to comprise a concave surface (not shown) configured to compatibly interface with the convex, spherical articular surface **420** of the tibial component. In other embodiments, the opposing surface of the femur and/or femoral component is modified to include a concave groove (not shown) configured to compatibly interface with the convex, articular ridge **400** of the tibial component. Further, in some embodiments the tibial component comprises a concave surface (not shown) and the femoral component comprises a convex surface (not shown) to compatibly interact with the tibial concave surface. Still further, in some embodiments the polyethylene coating (not shown) or the articular surface of the tibial component is configured to compatibly interface with a desired structure, shape or feature of the opposing femoral surface, thereby achieving normal knee function and movement throughout the knee's range of motion. For example, in some embodiments a tibial component is provided without an elevated, posterior portion or articulation feature. Rather, the surgeon may elect to leave the posterior portion of the patient's tibia which in turn interfaces with the femoral component to achieve normal knee function. Thus, in some embodiments a unicompartmental tibial component is provided to achieve normal knee function.

FIGS. **7A** and **7B** depict modifications to the femoral component **12** and the tibial component **14** to enable deeper knee flexion. Specifically, FIG. **7A** depicts a sagittal sectional view of a knee prosthesis **10** with a modified femoral component **12** and tibial component **14**. In FIG. **7A** an area **102** of the femoral component **12** is removed, as represented by the dashed line. This area **102** is above and between the posterior extreme **104** and the anterior side **106** of the posterior extreme **104**. By removing the area **102**, deeper flexion for prosthetic knee patients is partially achievable.

Similarly, with the tibial component **14** in FIG. **7B**, a medial side **25** may appear to be relatively lengthened in the anteroposterior dimension anteriorly by moving the articular surface **24** posterior and thereby having more of the tibial component anterior to the posteriorly-displaced medial articulation. This may give the appearance of having removed a posterior portion of the tibial component **14** and moved it to the anterior. A lateral side **27** of the tibial component may be shortened in the anteroposterior dimension relative to the medial side **25** (i.e., area **100**). FIG. **7B** illustrates the foregoing in plan view. In other words, by posteriorly shortening the lateral side **27** (i.e. by removing area **100**) of the tibial component **14** and by displacing the medial articular surface **24** more posterior, deeper knee flexion is possible. And, these modifications create the opportunity for a prosthetic knee patient to achieve a deeper knee flexion than possible with currently-available prosthetic knees.

In at least some embodiments of the invention, greater deep knee flexion can be achieved by providing an asymmetrical femoral component **12**. The asymmetrical femoral component **12** permits transfer of more than one-half of the force transmitted across the joint to be transmitted to the medial side, as occurs in the normal knee. Some such embodiments are illustrated with reference to FIGS. **17** and **18A**. FIG. **17** illustrates a radiograph of a knee at 160-degree flexion. In the radiograph, the femur **32** is viewed in the anteroposterior direction, and a medial condyle **66** of the femur **32**, a lateral condyle **68** of the femur **32**, and a patella **70** are visible. As may be appreciated by reference to the Figure, the medial-lateral width of the articulating portion of the medial condyle **66** is larger than the medial-lateral width

of the lateral condyle **68**. Specifically, in the Figure, the medial-lateral width of the articular portion of the medial condyle **66** is represented by X. As may be seen in the Figure, the medial-lateral width of the lateral condyle **68** is approximately 75% or less of the medial-lateral width X of the medial condyle **66**.

As may also be appreciated by reference to FIG. **17**, the center of the patella **70** is lateral to the midline of the knee. Specifically, in the Figure the medial-lateral distance between the most medial portion of the distal end of the femur **32** and the center of the patella **70** is represented by Y. As may be seen, the corresponding medial-lateral distance between the most lateral portion of the distal end of the femur **32** and the center of the patella **70** is approximately 75% or less (73% in the Figure) of Y. In some embodiments of the invention, the femoral component **12** may mimic the actual physical structure of the knee represented in FIG. **17**.

In such embodiments of the femoral component as illustrated in FIG. **18A**, the articular portion of the lateral condyle is, in its medial-lateral width, 75% or less than the width of the medial condyle. This allows for more than one half of the force that is transmitted across the joint to be transmitted to the medial side, which is what occurs in the normal knee. It also allows the patellar or trochlear groove to be lateralized because this groove distally is defined by its position between the medial and lateral condyles. In the normal knee the patella tends to be slightly lateralized on the femur and this lateral displacement of the groove accomplishes what many conventional total knee replacements accomplish by externally rotating the femoral component **12** in the total knee replacement. In one embodiment the condyles in the frontal plane are seen to be circular with a constant radius. The medial and lateral condyles do not need to be the same radius, but may both be circular when viewed in that plane. When viewed in the sagittal plane the condyles will be seen to have a closing radius posteriorly and anteriorly may blend into the anterior flange in the embodiments where an anterior flange is used.

FIG. **18A** illustrates a front view of one embodiment of a femoral component **12** in accordance with the described embodiments. In the Figure, illustrative measurements are illustrated to show features of the described embodiment, and are not meant to be limiting of the features of the described embodiments. As shown in FIG. **18A**, the total medial-lateral width of the femoral component **12** may be approximately 72 millimeters (mm). In this embodiment, the medial-lateral width of the medial femoral condylar surface **20** in the posterior portion of the medial posterior condyle is approximately 32 mm, while the medial-lateral width of the lateral femoral condylar surface **22** is approximately 22 mm. Thus, in the illustrated embodiment, the medial-lateral width of the lateral femoral condylar surface **22** is approximately 69% of the medial-lateral width of the medial femoral condylar surface **20**.

In the illustrated embodiment, a patellar groove **72** is defined by the space between the medial femoral condylar surface **20** and the lateral femoral condylar surface **22**. Because the medial-lateral width of the medial femoral condylar surface **20** is larger than the medial-lateral width of the lateral femoral condylar surface **22**, the patellar groove **72** is displaced laterally, which is what occurs in the normal knee. As may be appreciated by reference to FIGS. **18A** through **18C**, the patellar groove **72** may be provided at an angle as the patellar groove **72** moves from a most proximal anterior portion to a distal anterior portion to a distal posterior portion and to a proximal posterior portion. For

example, the angle of the patellar groove **72** in FIG. **18**, as measured from a sagittal plane is approximately 86 degrees.

Thus, the illustrated embodiment shows how a femoral component **12** in accordance with embodiments of the present invention may assist in achieving deeper knee flexion and, in some embodiments, full functional flexion, by providing an asymmetric femoral component **12**. The asymmetric femoral component **12** may assist in achieving deeper knee flexion by better simulating physiologic loading and patellar tracking. The asymmetric femoral component **12** allows for more normal loading of the joint with the medial side taking more of the load than the lateral side. Additionally, the asymmetrical femoral component **12** allows for more anatomically correct lateral tracking of the patella which may decrease problems of patellar pain, subluxation, and dislocation. One of skill in the art will readily recognize that in some embodiments the tibial component **14** may be modified to accommodate an asymmetric femoral component **12**.

As discussed herein, at least some embodiments of the present invention embrace providing deeper knee flexion capabilities where the medial femoral side stays relatively fixed and the lateral side glides forwards and backwards. While some embodiments embrace a knee with a tibial component that keeps the femoral component relatively fixed on the medial side and able to glide on the lateral side, other embodiments embrace a knee that is relatively fixed on the lateral side and able to glide on the medial side. This, for example, would apply to the tibial component.

Additionally, while the additional articular surface on the femoral component could be medial, lateral or both, at least some embodiments of the present invention embrace its application to use the Tibial and Femoral Full Flex articulations either medially, laterally, or both.

Referring now to FIGS. **18B** and **18C**, in some embodiments an abbreviated anterior flange **610** is provided to replace the trochlear surface or groove **72**. In some embodiments, anterior flange **610** is provided to compensate for individual patient anatomy where the lateral portion of the anterior condyle on the prosthesis extends or sits more proud than the bony condyle of the knee **200**. For these anatomies, the proud position of the prosthesis tents or otherwise separates the lateral soft tissues which may result in decreased flexion and discomfort or pain. In some embodiments, anterior flange **610** is provided without replacing anterior condyles **20** and **22** of the distal femur **210**, such as for use with a patient having severe patello-femoral arthritis that would not be adequately treated with the prosthesis shown in FIGS. **12A**, **12B**, **14** and **16Q** through **16S**. Providing only anterior flange **610** may also provide relief with reduced cost and/or reduced evasiveness. In other embodiments, anterior flange **610** is provided in addition to replacing the anterior condyles **20** and **22**.

In some embodiments, the length of the abbreviated anterior flange **610** is very short so as to only replace a portion of the trochlear surface **72**. In other embodiments, the length of anterior flange **610** is extended to entirely replace trochlear surface **72**. Further, in some embodiments anterior flange **610** is extended distally between the distal condyles **20** and **22** to a length approximately equal to flanges of currently available, non-abbreviated prostheses.

Referring now to FIG. **21** a perspective side view of a knee **200** is shown. In at least some of the embodiments of the present invention, greater deep knee flexion may be further provided, improved, or enhanced by removing a portion of the popliteal surface **202** of the femur **210**. The popliteal surface **202** may include bone proximal to the

posterior articular surfaces of the medial condyle, the lateral condyle, or both the medial and lateral condyles. Resection of the popliteal surface **202** may be accomplished by any appropriate method known in the art. For example, in one embodiment a portion of the tibia is first resected thereby providing sufficient clearance to resect the necessary portion of the popliteal surface **230**.

The amount of bone resected from the tibia, the femur or both will vary from individual to individual depending upon the specific anatomy of the tibia and the femur. The resected popliteal surface **230** provides additional clearance between opposing surfaces of the tibia **220** and the femur **210**. Specifically, the resected popliteal surface **230** prevents an impingement of the posterior articulate surface **250** of the medial condyle **240** of the tibia **220** on the femur **210** during deep flexion of the knee **200**. As such, the knee **200** may flex freely without the tibia **220** adversely binding on, or contacting any portion of the femur **210**. Additionally, the resected popliteal surface **230** may provide flexion exceeding 140°. In one embodiment, the resected popliteal surface **230** provides flexion exceeding 160°.

Referring now to FIG. **22**, a perspective side view of a knee **200** is shown following resection of the popliteal surface **202** to provide the resected surface **230**. As previously discussed, resection of the popliteal surface **230** may be accomplished by any appropriate method known in the art. However, in one embodiment a resection block **300** is utilized to guide a cutting device **310** in making the resection **230**. The resection block **300** is comprised of a metallic material, similar to the metallic materials previously discussed, and includes an outer surface **312**, an inner surface **314**, and a slot **316**. The outer surface **312** is contoured and adapted to substantially overlap the lateral and medial condyles of the femur **210**. The inner surface **314** includes a plurality of angled surfaces that mirror the resected and shaped surfaces of the lateral and medial condyles of the femur **210**. Thus, the inner surface **314** of the resection block **300** is adapted to compatibly engage the resected surfaces **62**, **64**, and **366** of the femur **210**. The engaged resection block **300** and femur **210** are further secured via a plurality of fasteners **320**, such as screws. This may not be necessary in all cases. The fasteners **320** are required only to firmly attach the guide to the femur. In some embodiments, the interaction between the guide and the femur is such that the guide is held firmly in place without fasteners. In another embodiment, the guide is held in place by any means to facilitate an accurate resection of the above mentioned area of the femur.

The interaction between the resection block **300** inner surface **314** and the resected surfaces **62**, **64**, and **366** of the femur **210** accurately aligns the slot **316** with the popliteal surface **202** of the femur **210**. The slot **316** generally comprises an external opening **330** and an internal opening **332**. The external opening **330** comprises a first width that is slightly greater than the width **338** of the cutting device **310**. As such, the external opening **330** is adapted to compatibly receive the cutting device **310**. The internal opening **332** is positioned exactly adjacent to the popliteal surface **202** and comprises a second width that is greater than the first width and approximately equal to the desired width of the popliteal resection **230**. Thus, the walls **334** of the slot taper inwardly from the second opening to the first opening thereby providing a wedged slot **316**.

The cutting device **310** may include any device compatible with the slot **316**. In one embodiment an oscillating blade **340** is provided. The oscillating blade **340** includes a shank **342**, a cutting head **344** and a stop **346**. The shank **342**

generally comprises a surface that is adapted to compatibly and securely engage a tool (not shown) capable of moving the blade **340** relative to the resection block **300** and femur **210**. The cutting head **344** generally comprises a plurality of teeth suitable for removing the desired portions of the popliteal surface **202** to form the resection **230**. The stop **346** generally comprises a ferule, a crimp, or some other feature that provides a point on the blade **340** that is wider than the first opening **330** of the slot **316**. As such, the stop **346** is unable to enter the slot **316** thereby limiting the depth into which the blade **340** is permitted to enter the slot **316**. Thus, the stop **346** acts as a depth gauge to control or limit the final depth of the popliteal resection **230**. In one embodiment, the stop **346** further comprises a set screw whereby the stop **346** is loosened and repositioned on the blade **340** to change the depth into which the blade **340** is permitted to enter the slot **316**. In another embodiment, the cutting device **310** is a burr bit having a stop **346** to limit the cutting depth of the burr.

Referring now to FIG. **22A**, an underside, perspective view of the femur **210** and resection block **300** are shown. In one embodiment, the resection block **300** includes a first slot **316** and a second slot **318** separated by a connecting portion **326** of the resection block **300**. The first slot **316** is positioned adjacent to the medial condyle **66** of the femur **210** and the second slot **318** is positioned adjacent to the lateral condyle **68**. Each slot is positioned at a different height relative to the asymmetric, natural positions of the medial and lateral condyles **66** and **68**. Thus, the first and second slots **316** and **318** of the resection block **300** are adapted to optimally resect the popliteal surface **202** of the femur **210** with respect to the asymmetric positions of the condyles **66** and **68**. In another embodiment, the first and second slots **316** and **318** are positioned at equal heights so as to provide a resected popliteal surface **230** that is symmetrical without respect to the asymmetrical condyles **66** and **68**. In yet another embodiment, the positioning of the external opening **330** relative to the internal opening **332** of the first slot **316** is different than the positioning of the external opening **330** relative to the internal opening **332** of the second slot **318**. As such, the radius of each wedge opening **316** and **318** is different and the resultant contours or shapes of the resected popliteal surface **230** for the first and second slots **316** and **318** will be asymmetrical. In another embodiment, connecting portion **326** is eliminated thereby providing a single guide slot. In this embodiment, upper and lower portions of the guide are held in place relative to one another via lateral and medial bridges. The lateral and medial bridges maintain the position of the upper and lower portions of the guide, as well as define the outer edges of the slot. In another embodiment, lateral and medial bridges are used to provide multiple slots within the guide.

Referring now to FIGS. **22** and **22A**, the popliteal resection **230** is made by inserting the cutting device **310** into the slot **316** and removing the popliteal surface **202** to the desired depth, as limited by the stop feature **346** and the radial limitations of the wedged slot **316**. The wedged shape of the slot **316** permits the cutting device **310** to be pivoted along the radius of the wedge, wherein the contact between the stop **346** and the external opening **330** acts as a fulcrum for the radius of the wedge. The resultant resection **230** therefore comprises a radial surface configured and shaped to receive the femoral component **12** of the knee prosthesis. Following formation of the popliteal resection **230**, the screws **320**, or other stabilizing methods, and the resection block **300** are removed from the femur **210**.

Referring now to FIG. **23**, a cross-sectional side view of a knee **200** is shown following resection of the popliteal

surface **230**. The femoral component **12** of the knee prosthesis may be modified to correspond to the resected portion **230** of the popliteal surface **202**. For example, in one embodiment a portion **212** of the femoral component **12** of the knee prosthesis is extended and contoured to seat within the resected portion **230** of the popliteal surface **202**. As such, the posterior articular surface **250** of the medial condyle **240** of the tibia **220** compatibly and smoothly interacts with the extended portion **212** thereby further enabling the knee **200** to achieve deep flexion. Furthermore, the interaction between the posterior articular surface **250** and extended portion **212** prevents the posterior articular surface **250** from binding on a terminal surface **214** of the femoral component and displacing the femoral component **12** in an anterior direction **300** during deep flexion. In some embodiments of the present invention, the extended portion **212** is used in conjunction with a tibial implant having a spherical medial side. In another embodiment, the extended portion **212** is used in conjunction with any knee replacement that will allow knee flexion to 120° or greater. For example, in one embodiment a femoral component of a knee prosthesis system is modified to include a piece of metal up the back of the posterior portion of the component to provide an extended portion **212** compatible with the tibial component of the knee prosthesis system.

In some embodiments of the present invention including the extended portion **212**, the femoral component **12** does not include an interior flange or any provision for patella-femoral articulation, as shown in FIGS. **15B** and **16B** above. As such, the lack of an anterior flange allow the component **12** to be impacted onto the femur in a relatively conventional manner, except that the component **12** is implanted after being rotated posteriorly relative to a conventional prosthesis. Additionally, the femoral component **12** can be used without a separate patella-femoral articular implant. In some embodiments, the component **12** is used with a modular flange attached to the condylar implant to provide femoral articulation of the patella. In another embodiment, the femoral component **12** is used with separate, unattached patella-femoral implants. Finally, in another embodiment a separate femoral flange is used for a patella that does not have an implanted component.

Referring now to FIG. **23A**, a cross-sectional side view of a knee **200** is shown following resection of the popliteal surface **230**, wherein the femoral component **12** is used in conjunction with a tibial component **14**. In some embodiments of the present invention, the above described femoral component **12** is used in conjunction with a conventional tibial component **14** that does not have the tibial full flex articulation. For example, in one embodiment the above described femoral component **12** is used in conjunction with a tibial component **14** that has the center of the medial tibial articulation displaced posteriorly. In another embodiment, the femoral component **12** is used in conjunction with a tibial component **14** that has the center of the medial tibial articulation in a position that corresponds with currently available designs. In addition to occupying or lining the resected popliteal surface **230**, the extended portion **212** may include additional features to modify the position of the tibia and the femur during full flexion.

For example, in one embodiment the extended portion **212** is modified to rotate the tibia relative to the femur with the knee in full flexion. In another embodiment, the extended portion **212** is modified to prevent rotation of the tibia relative to the femur with the knee in full flexion. In yet another embodiment, the extended portion **212** is modified to include a spherical surface on its upper or most proximal

portion. As such, this spherical surface allows the tibia to rotate relative to the femur in full flexion. In some implementations of the present invention it may be desirable to have the spherical surface articulate with a corresponding concave surface in the femoral full flex articulation. Such a concavity would offer medial-lateral stability, provide area contact between the femoral and tibial components, and decrease polyethylene wear of the prosthesis. Referring again to FIG. 23, in some implementations of the present invention, the femoral component 12 is used in conjunction with a non-resected posterior portion of the patient's own tibial plateau to articulate with extended portion 212.

Referring now to FIGS. 24 through 28, some embodiments of tibial component 14 are further modified to include a stem 500 generally attached to the anterior undersurface of tibial component 14. As shown in FIG. 24, anterior placement of stem 500 is calculated to compensate for and decrease the compressive load applied to the posterior tibia during flexion of the knee joint. As compressive load is applied to the posterior tibia, stem 500 forms an interface with the inner surface 520 of the tibial anterior cortex 518 thereby preventing at least one of rotation, sinking and/or subsidence of tibial component 14 relative to the tibia 220. Thus, the shape, size, angle and placement of stem 500 are selected to achieve a desired interface between the stem 500 and inner surface 520.

In some embodiments stem 500 is curved to closely approximate the contours of inner surface 520, as shown in FIGS. 24 and 25. In other embodiments stem 500 is tapered such that portions of the stem surface contact various portion or areas of inner surface 520, as shown in FIG. 26. Still, in other embodiments stem 500 is extended such that a tip portion 530 of stem 500 contacts inner surface 520. Stem 500 may further include a tapered base 540 to increase the stability of stem 500 while under compressive loads. Finally, in some embodiments stem 500 comprises an adjustable linkage 550 whereby the angle of stem 500 is adjusted to accommodate the individual anatomy of the patient, as shown in FIG. 28. In some embodiments stem 500 further includes an adjustable tip 560 whereby the length of stem 500 is adjusted to accommodate the individual anatomy of the patient. For example, in some embodiments tip 560 is adjustable coupled to shaft 570 via a set of threads 580. In other embodiments tip 560 is slidably coupled to shaft 570 wherein the position of the tip 560 relative to the shaft 570 is maintained via a set screw, a mechanical impingement or an adhesive (not shown). Thus, stem 500 may generally comprise any shape, length or angle necessary to accommodate the needs of the patient.

Thus, as discussed herein, the embodiments of the present invention embrace knee prostheses. In particular, embodiments of the present invention relate to systems and methods for providing deeper knee flexion capabilities for knee prosthesis patients, and more particularly, to: (i) providing a flexion attachment to the femoral component of a knee prosthesis or providing an extension of the femoral component, which when integrated with both the femoral component and a patient's femur, results in a greater articular surface area of the femoral component; (ii) making modifications to the internal geometry of the femoral component and the associated femoral bone cuts with methods of implantation, (iii) providing asymmetrical condylar or articular surfaces on the tibial component of the knee prosthesis; (iv) making modifications to the tibial and femoral components of a knee prosthesis, including removing certain areas of the tibial and femoral components; (v) having asymmetric femoral condyles, including having a

closing radius on the femoral component; and (vi) providing femoral and/or tibial full flex articulations, wherein all of the foregoing result in deeper knee flexion capabilities for knee prosthesis patients than previously achievable.

The present invention may be embodied in other specific forms without departing from its spirit or essential characteristics. For example, one of skill in the art will appreciate that the methods and systems of the present invention may be modified for use in unicompartmental knee arthroplasty procedures and prostheses. Thus, the described embodiments are to be considered in all respects only as illustrative and not restrictive. The scope of the invention is, therefore, indicated by the appended claims rather than by the foregoing description. All changes that come within the meaning and range of equivalency of the claims are to be embraced within their scope.

What is claimed is:

1. A knee prosthesis comprising:

a tibial component comprising an undersurface and a stem that extends from the undersurface, wherein the stem is configured to contact an inner, anterior surface of the tibia when the stem is inserted into the tibia and the undersurface of the tibial component is in contact with a resected surface of the tibia.

2. A method of applying a tibial component to a tibia of a patient, the method comprising:

preparing the tibia to receive the tibial component by removing bone from a proximal end of the tibia;

obtaining the tibial component, wherein the tibial component comprises:

an undersurface; and

a stem that extends from the undersurface, wherein the stem is configured to contact an inner, anterior surface of the tibia when the stem is inserted into the tibia and the undersurface of the tibial component is in contact with a resected surface of the tibia; and

seating the tibial component on the tibia such that the stem contacts the inner, anterior surface of the tibia when the stem is inserted into the tibia and the undersurface of the tibial component is in contact with the resected surface of the tibia.

3. The method of claim 2, wherein the tibial component comprises a unicompartmental component, and wherein the preparing the tibia comprises removing sufficient bone to seat the unicompartmental component at the proximal end of the tibia.

4. The method of claim 2, wherein the stem comprises a portion that is configured to approximate a contour of the inner, anterior surface of the tibia when the stem is inserted into the tibia.

5. The method of claim 2, wherein the tibial component further comprises a pivot joint that allows a portion of the stem to pivot anteriorly and posteriorly, and wherein the method further comprises adjusting the pivot joint.

6. The method of claim 5, wherein the stem is configured to pivot through a single plane.

7. The method of claim 2, wherein a part of the stem extends anteriorly to at least an end of an anterior edge of the tibial component.

8. The method of claim 2, wherein a majority of the stem is disposed closer to an anterior edge than to a posterior edge of the tibial component.

9. The method of claim 2, wherein the tibial component comprises an adjustable linkage that allows a length of the stem to be adjusted, and wherein the method further comprises adjusting the length of the stem.

29

10. The prosthesis of claim 1, wherein the tibial component is configured to replace a proximal portion of the tibia, and wherein the tibial component further comprises:

a tibial articular surface; and

a raised articulation feature, with the raised articulation feature being disposed posteriorly on the tibial articular surface.

11. The prosthesis of claim 10, wherein the tibial component comprises a unicompartamental component.

12. The prosthesis of claim 10, wherein the raised articulation features extends along a posterior edge of the tibial component in a general medial-lateral direction.

13. The prosthesis of claim 10, wherein the articulation feature comprises a proximal-most portion with a posterior articular surface disposed posterior to the proximal-most portion of the articulation feature, and wherein the posterior articular surface is configured to articulate against an articular surface of at least one of (i) a femur and (ii) a femoral component.

14. The prosthesis of claim 13, wherein a majority of the stem is disposed closer to an anterior edge than to a posterior edge of the tibial component.

15. The prosthesis of claim 13, further comprising the femoral component, the femoral component defining an incurved articulation surface that is configured to articulate against the posterior articular surface of the tibial component.

16. The prosthesis of claim 15, wherein the incurved articulation surface is disposed at a proximal portion of a posterior, medial condylar portion of the femoral component.

30

17. A tibial component comprising:
an undersurface;

a tibial stem that extends from the undersurface and that is configured to contact an inner anterior surface of tibial bone when the tibial stem is inserted in a tibia and the undersurface contacts a resected proximal surface of the tibia; and

a raised articulation feature disposed posteriorly on the tibial component, the articulation feature comprising a proximal-most portion with a posterior articular surface disposed posterior to the proximal-most portion of the articulation feature, the posterior articular surface being configured to articulate against at least one of (i) a femur and (ii) a femoral component that is configured to replace a distal portion of the femur.

18. The component of claim 17, wherein the articulation feature is disposed on a medial portion of the tibial component and wherein the inner anterior surface of tibial bone comprises an anterior cortex of the tibia.

19. The component of claim 17, wherein a majority of the tibial stem is disposed closer to an anterior edge than to a posterior edge of the tibial component.

20. The component of claim 17, wherein at least one of (i) a length and (ii) an angle of the tibial stem is adjustable, and wherein the stem is configured to contact the inner anterior surface to compensate for a compressive load applied to the articulation feature when the stem is inserted into the tibia and when the femur is flexed with respect to the tibia.

* * * * *