

US009691434B2

(12) **United States Patent**
Hirano et al.

(10) **Patent No.:** **US 9,691,434 B2**
(45) **Date of Patent:** **Jun. 27, 2017**

(54) **FEEDTHROUGH CONNECTOR FOR HERMETICALLY SEALED ELECTRONIC DEVICES**

(58) **Field of Classification Search**
CPC H01R 13/58; H01R 13/521; H01R 13/60;
G06F 1/181; G11B 33/1446;

(Continued)

(71) Applicant: **HGST Netherlands B.V.**, Amsterdam (NL)

(56) **References Cited**

U.S. PATENT DOCUMENTS

(72) Inventors: **Toshiki Hirano**, San Jose, CA (US);
Vipin Ayanoor Vitikkate, Palakkad-Kerala (IN)

5,282,099 A 1/1994 Kawagoe et al.
5,337,202 A 8/1994 Jabbarai et al.

(Continued)

(73) Assignee: **WESTERN DIGITAL TECHNOLOGIES, INC.**, Irvine, CA (US)

FOREIGN PATENT DOCUMENTS

(*) Notice: Subject to any disclaimer, the term of this patent is extended or adjusted under 35 U.S.C. 154(b) by 0 days.

CN 101911200 12/2010
CN 102481454 5/2012

(Continued)

OTHER PUBLICATIONS

(21) Appl. No.: **15/223,976**

SGA Technologies, Multi Pin Feedthrough, <http://www.sgatech.co.uk/glass-to-metal-seals/types-of-seal/multi-pin-feedthrough>, Received Jan. 29, 2014, Retrieved Mar. 6, 2014.

(22) Filed: **Jul. 29, 2016**

(Continued)

(65) **Prior Publication Data**

US 2016/0336044 A1 Nov. 17, 2016

Primary Examiner — Brian Miller

(74) *Attorney, Agent, or Firm* — Kunzler Law Group, PC

Related U.S. Application Data

(63) Continuation of application No. 14/518,853, filed on Oct. 20, 2014, now Pat. No. 9,431,759.

(57) **ABSTRACT**

(51) **Int. Cl.**
G11B 25/04 (2006.01)
G11B 33/12 (2006.01)

(Continued)

Disclosed herein is one embodiment of an apparatus that includes a housing that defines an interior cavity. The housing also includes a spring aperture. The apparatus further includes a spring coupled to the housing over the spring aperture, with the spring having a deflection portion and a feedthrough aperture. The apparatus also has an electrical connector coupled to the spring and extending through the feedthrough aperture and the spring aperture. The electrical connector may have a plurality of electrical traces extending from a location external to the housing to a location within the interior cavity of the housing.

(52) **U.S. Cl.**
CPC **G11B 33/122** (2013.01); **G06F 1/181** (2013.01); **G11B 25/043** (2013.01);
(Continued)

15 Claims, 9 Drawing Sheets

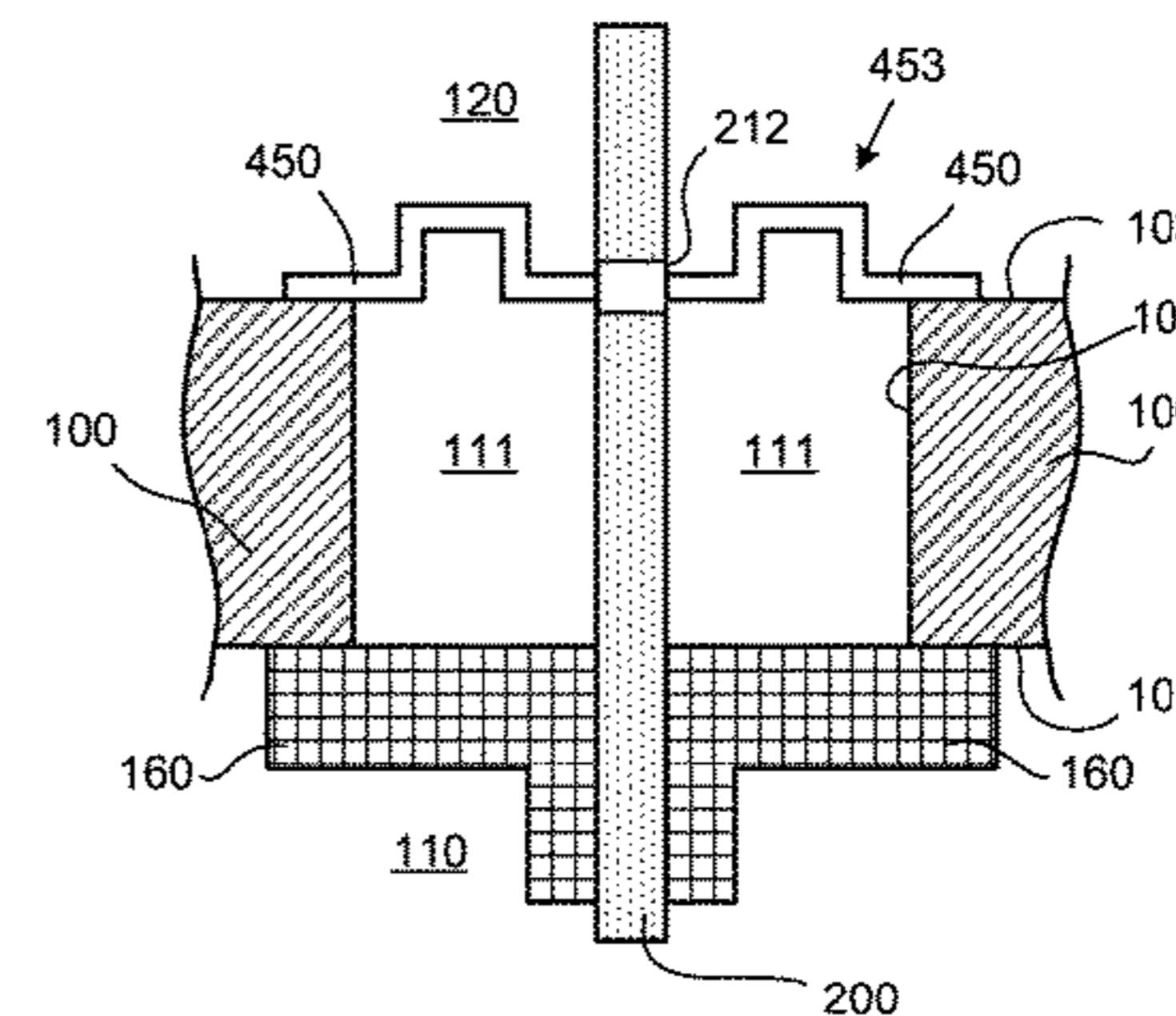
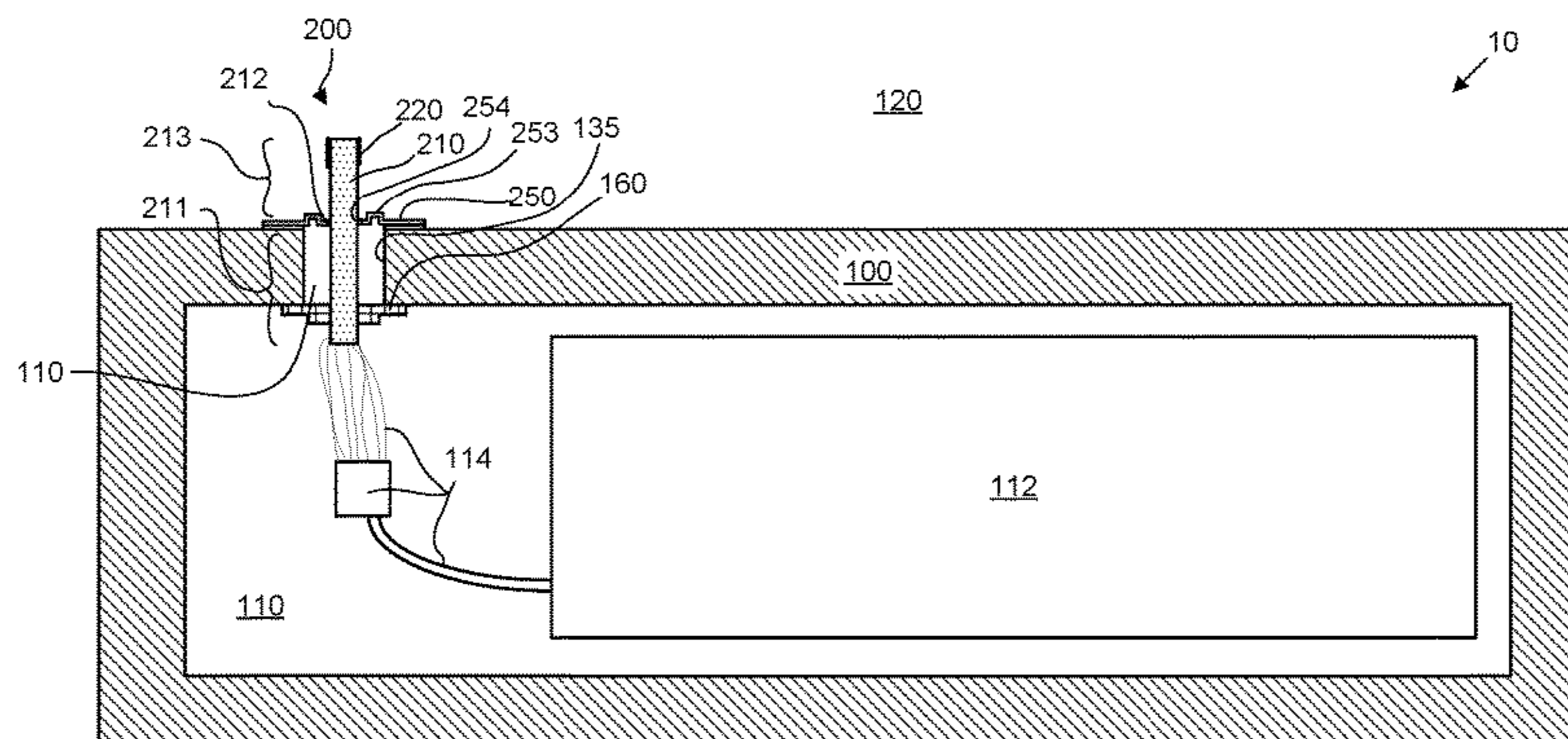

(51) **Int. Cl.**
H01R 13/58 (2006.01)
G06F 1/18 (2006.01)
H01R 13/60 (2006.01)
H01R 13/52 (2006.01)
G11B 33/14 (2006.01)
H05K 5/06 (2006.01)

(52) **U.S. Cl.**
 CPC *G11B 33/1446* (2013.01); *H01R 13/521*
 (2013.01); *H01R 13/58* (2013.01); *H01R*
13/60 (2013.01); *H05K 5/067* (2013.01);
H05K 5/069 (2013.01); *H01R 2201/06*
 (2013.01)

(58) **Field of Classification Search**
 CPC G11B 33/122; G11B 33/08; G11B 25/043;
 G11B 33/022; H05K 1/118
 USPC 360/99.25
 See application file for complete search history.

(56) **References Cited**

U.S. PATENT DOCUMENTS

5,454,157	A	10/1995	Ananth
5,541,787	A	7/1996	Jabbari et al.
5,816,861	A	10/1998	Cheng
5,931,697	A	8/1999	Jeong
5,956,213	A	9/1999	Dague et al.
5,994,975	A	11/1999	Allen et al.
6,129,579	A	10/2000	Cox
6,168,459	B1	1/2001	Cox
6,305,975	B1	10/2001	Steiner
6,454,572	B1	9/2002	Konetski et al.
6,567,235	B2	5/2003	Kasetty et al.
6,594,107	B2	7/2003	Hayakawa et al.
6,678,112	B1	1/2004	Kaneko
6,970,322	B2	11/2005	Bernett
6,989,493	B2	1/2006	Hipwell, Jr. et al.
7,016,145	B2	3/2006	Gunderson et al.
7,123,440	B2	10/2006	Albrecht et al.
7,599,147	B2	10/2009	Gunderson
7,872,836	B2	1/2011	Shindo et al.
7,876,527	B2	1/2011	Nakamiya et al.
8,035,923	B2	10/2011	Suzuki et al.
8,059,364	B1	11/2011	Andrikowich et al.

8,098,454	B2	1/2012	Kouno et al.
8,179,631	B2	5/2012	Aoyagi et al.
8,194,348	B2	6/2012	Jacoby et al.
3,279,552	A1	10/2012	Stipe
8,373,075	B2	2/2013	Munns et al.
8,487,187	B2	7/2013	VandenEynden et al.
8,749,914	B2	6/2014	Otake et al.
9,001,458	B1	4/2015	Vitikkate et al.
9,196,303	B2	11/2015	Hirano
2002/0141107	A1	10/2002	Kasetty et al.
2003/0022533	A1	1/2003	Joo
2006/0002067	A1	1/2006	Gunderson et al.
2006/0050429	A1	3/2006	Gunderson
2008/0144273	A1	6/2008	Mewes et al.
2008/0171465	A1	7/2008	Lauriano et al.
2008/0182431	A1	7/2008	Evans
2008/0259503	A1	10/2008	Aoyagi et al.
2009/0034113	A1	2/2009	Hashi et al.
2009/0097163	A1	4/2009	Suzuki et al.
2009/0097375	A1	4/2009	Uefune et al.
2009/0168233	A1	7/2009	Kouno et al.
2010/0068936	A1	3/2010	Foster
2010/0328815	A1	12/2010	Nakatsuka et al.
2012/0182645	A1	7/2012	Kurokawa et al.
2015/0098178	A1	4/2015	Otake et al.
2015/0257293	A1	9/2015	Hirano et al.
2015/0355685	A1	12/2015	Hirano
2015/0359115	A1	12/2015	Hirano
2016/0111124	A1	4/2016	Ku

FOREIGN PATENT DOCUMENTS

EP	0529345	3/1993
JP	06-54275 U	7/1994
JP	2007088104	4/2007
KR	19931361	1/1993
KR	20070093450	9/2007
KR	20130037203	4/2013

OTHER PUBLICATIONS

Notice of Final Rejection and Decision of Refusal of the Amend-
ment for Korean Patent Application No. KR10-2015-0031918 dated
Jan. 2, 2017 with English Summary.
Office Action for Chinese Patent Application No. 201510341901.1
dated Nov. 21, 2016.
Office Action for Korean Patent Application No. 10-2015-0031918
dated Nov. 1, 2016.

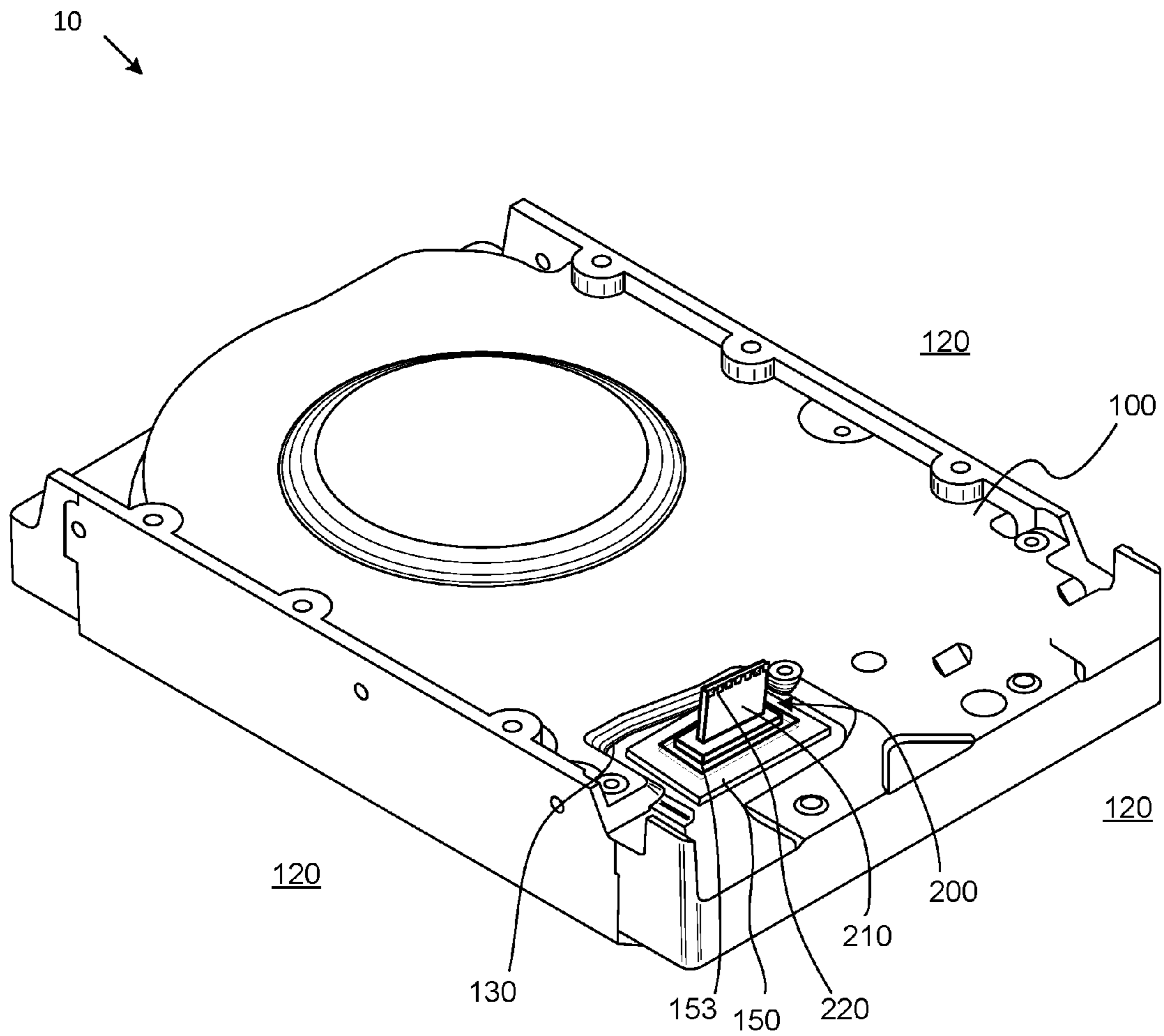
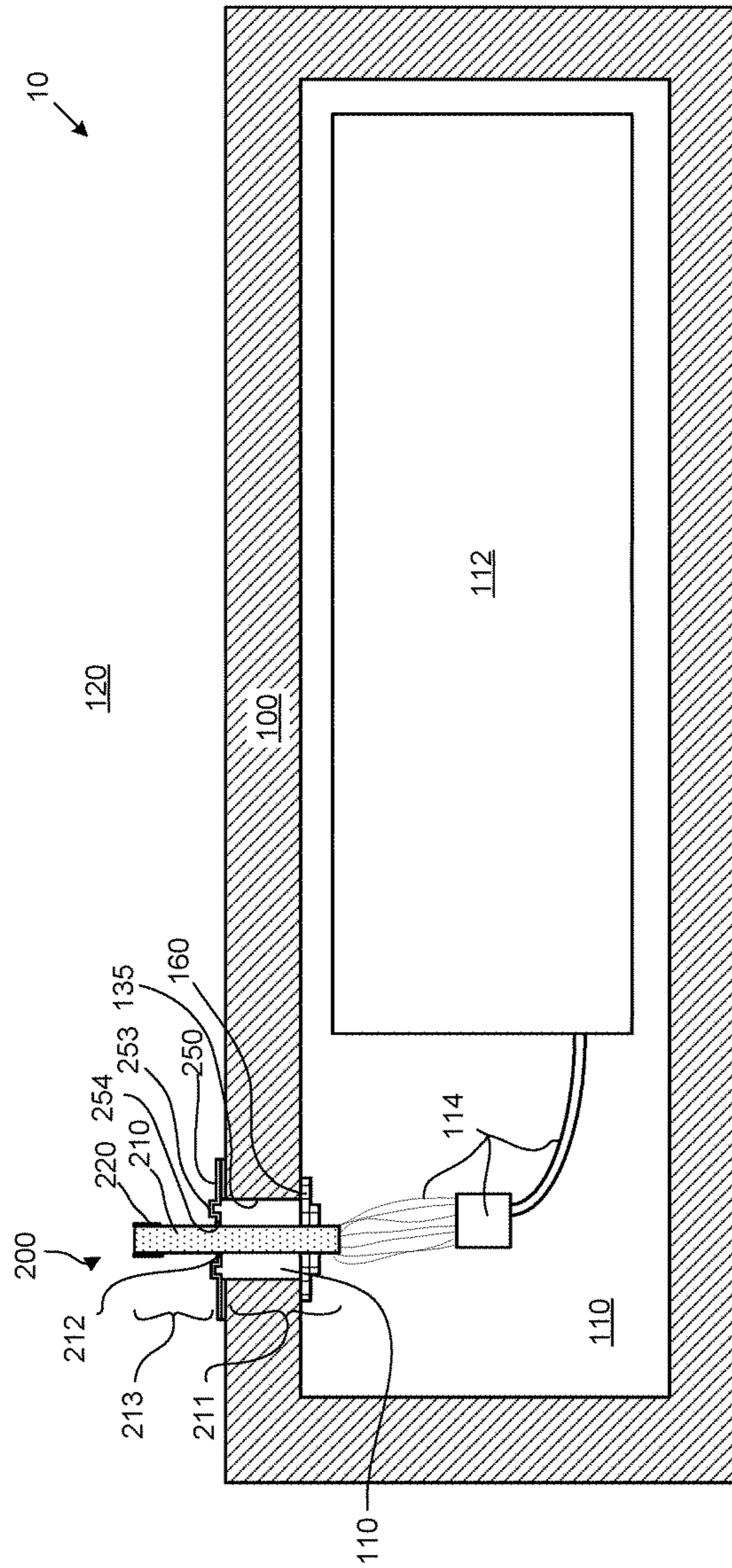

Fig. 1



120

Fig. 2

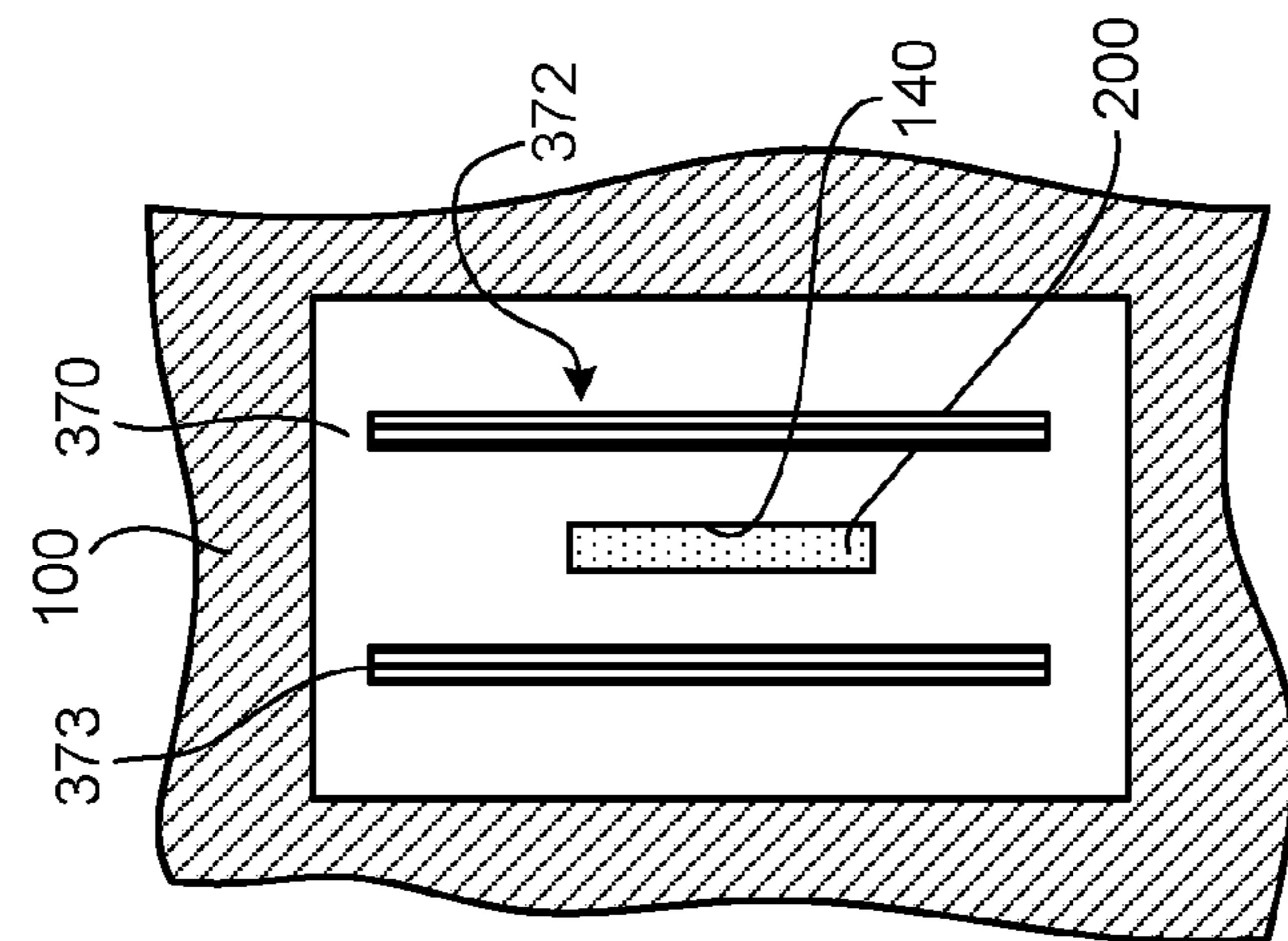

Fig. 3A

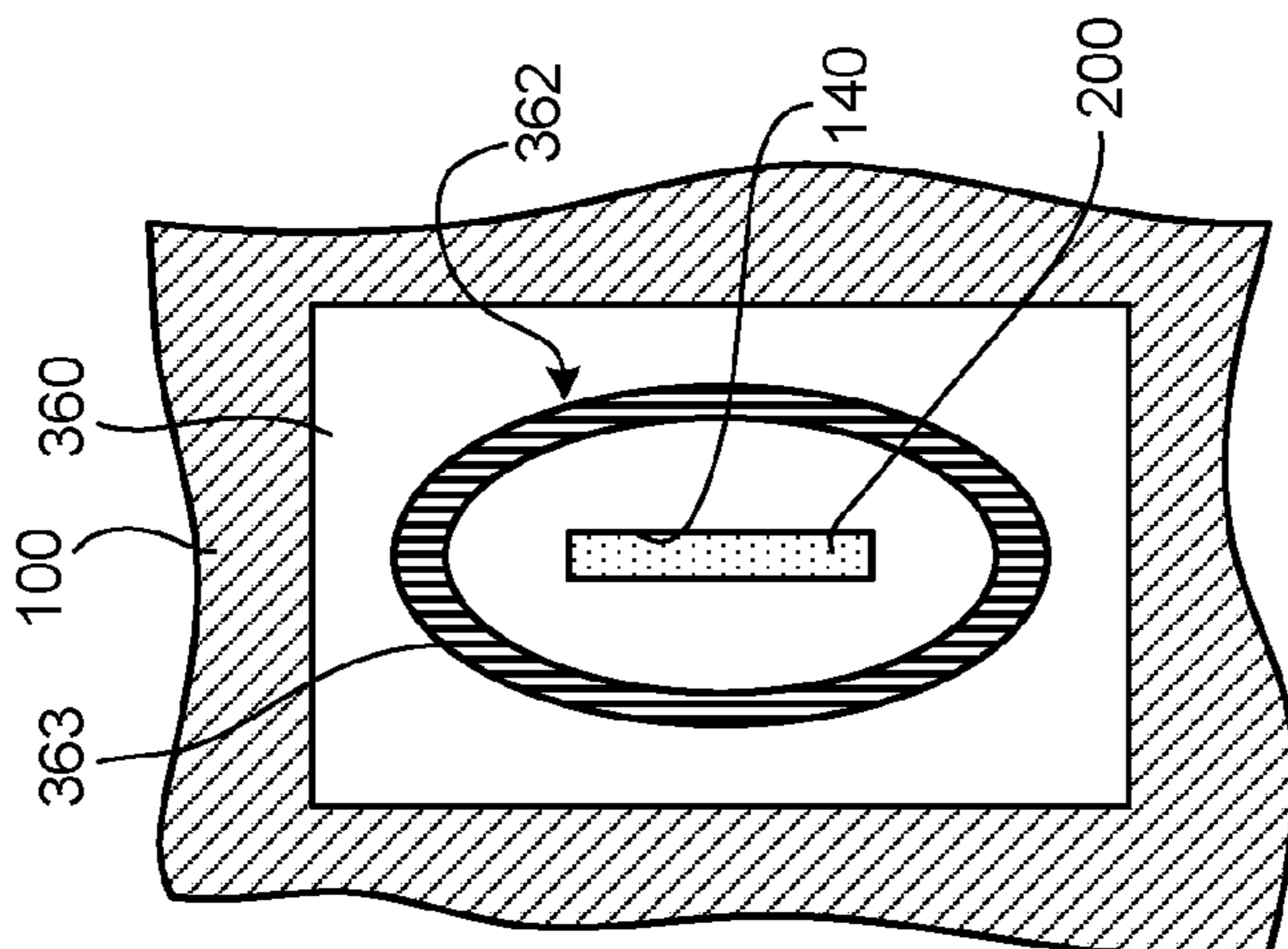

Fig. 3B

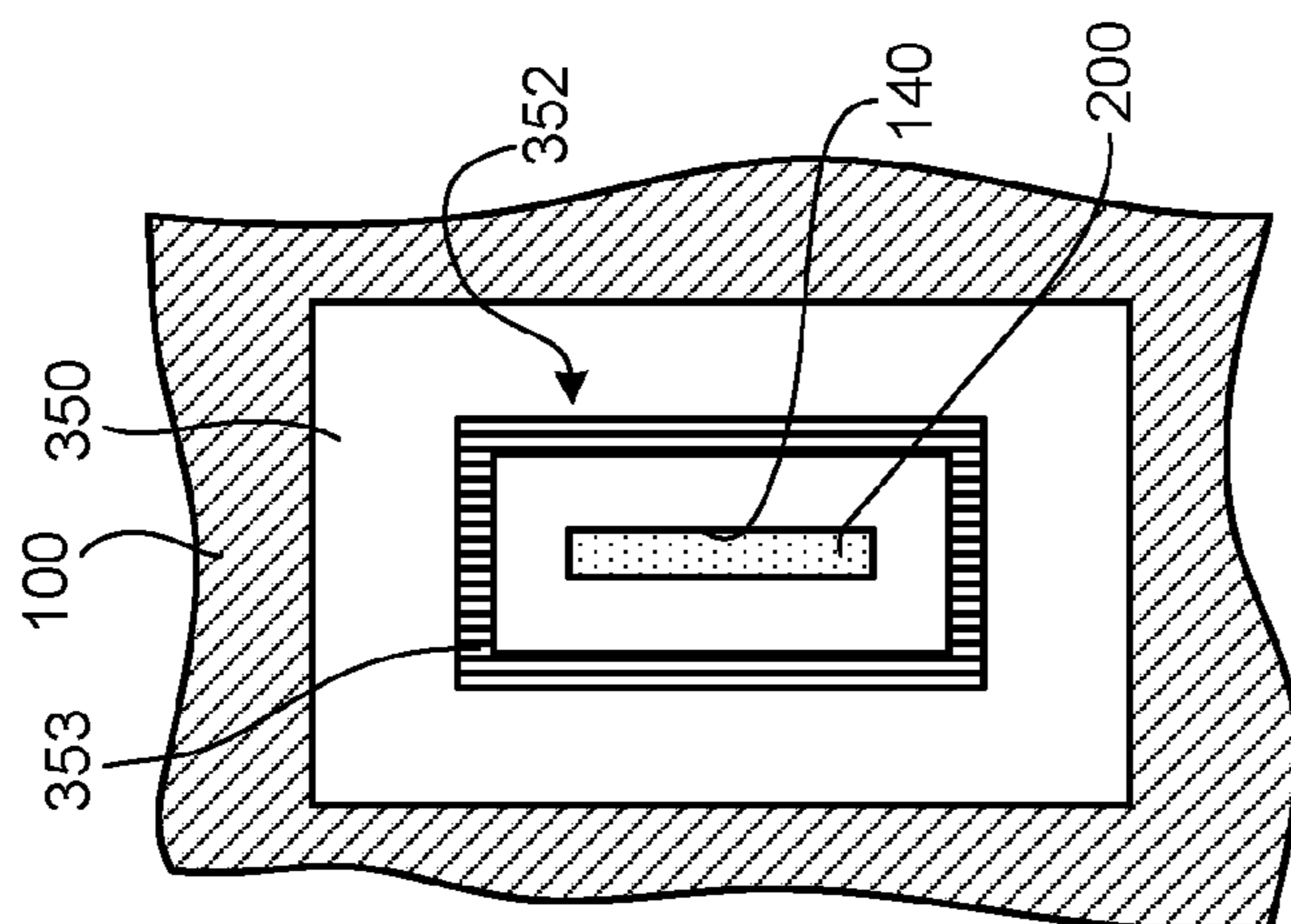

Fig. 3C

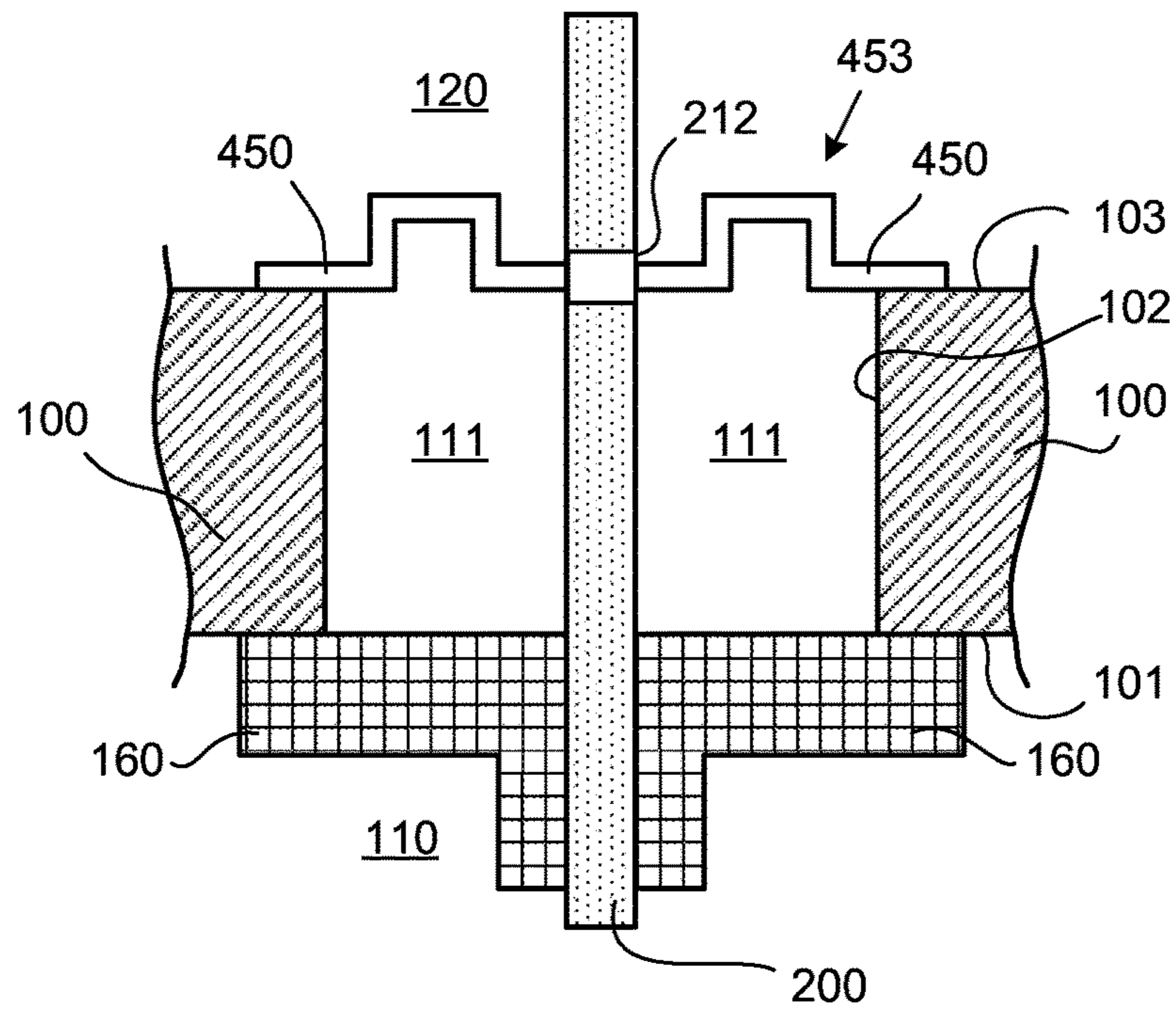

Fig. 4A

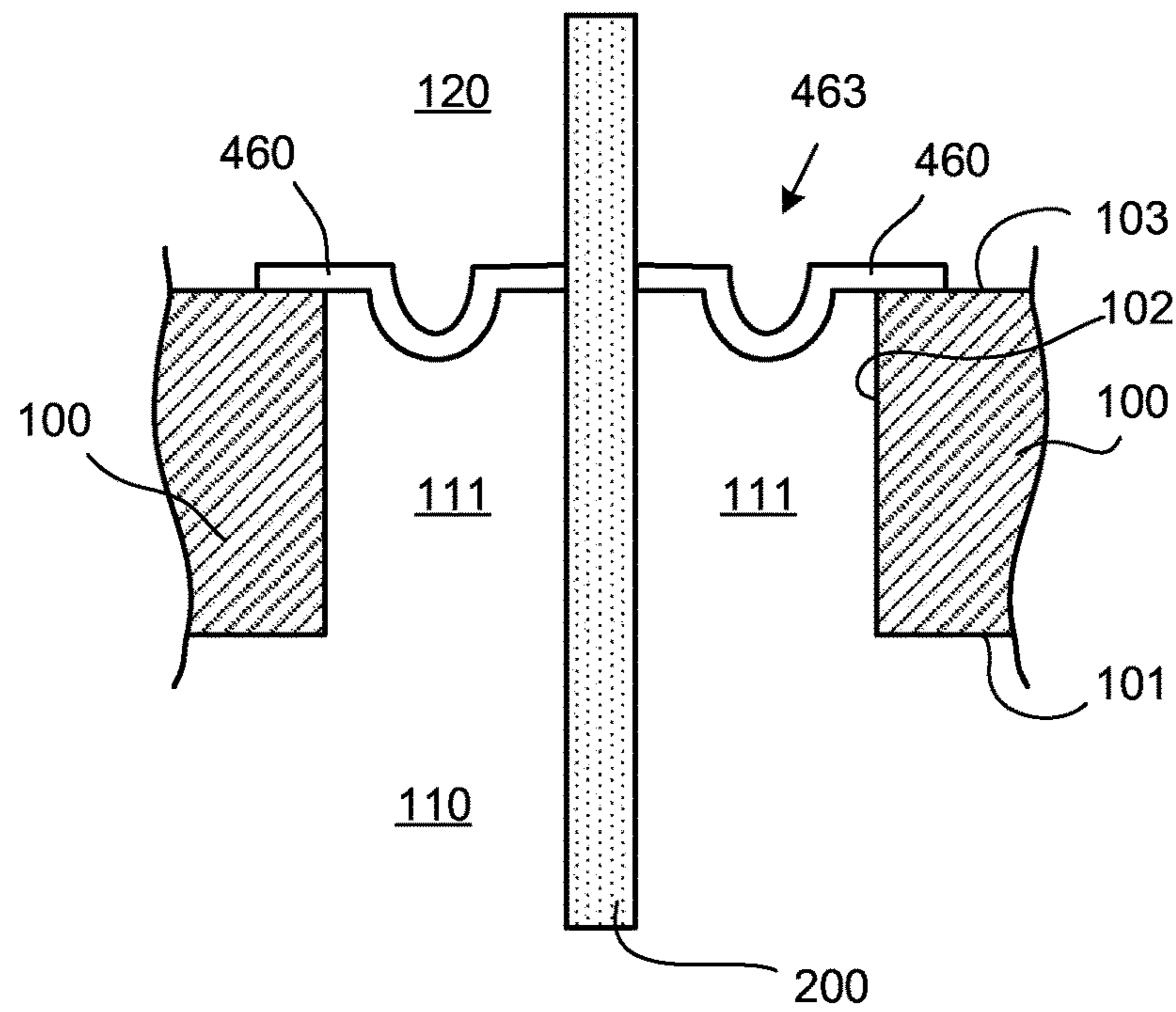

Fig. 4B

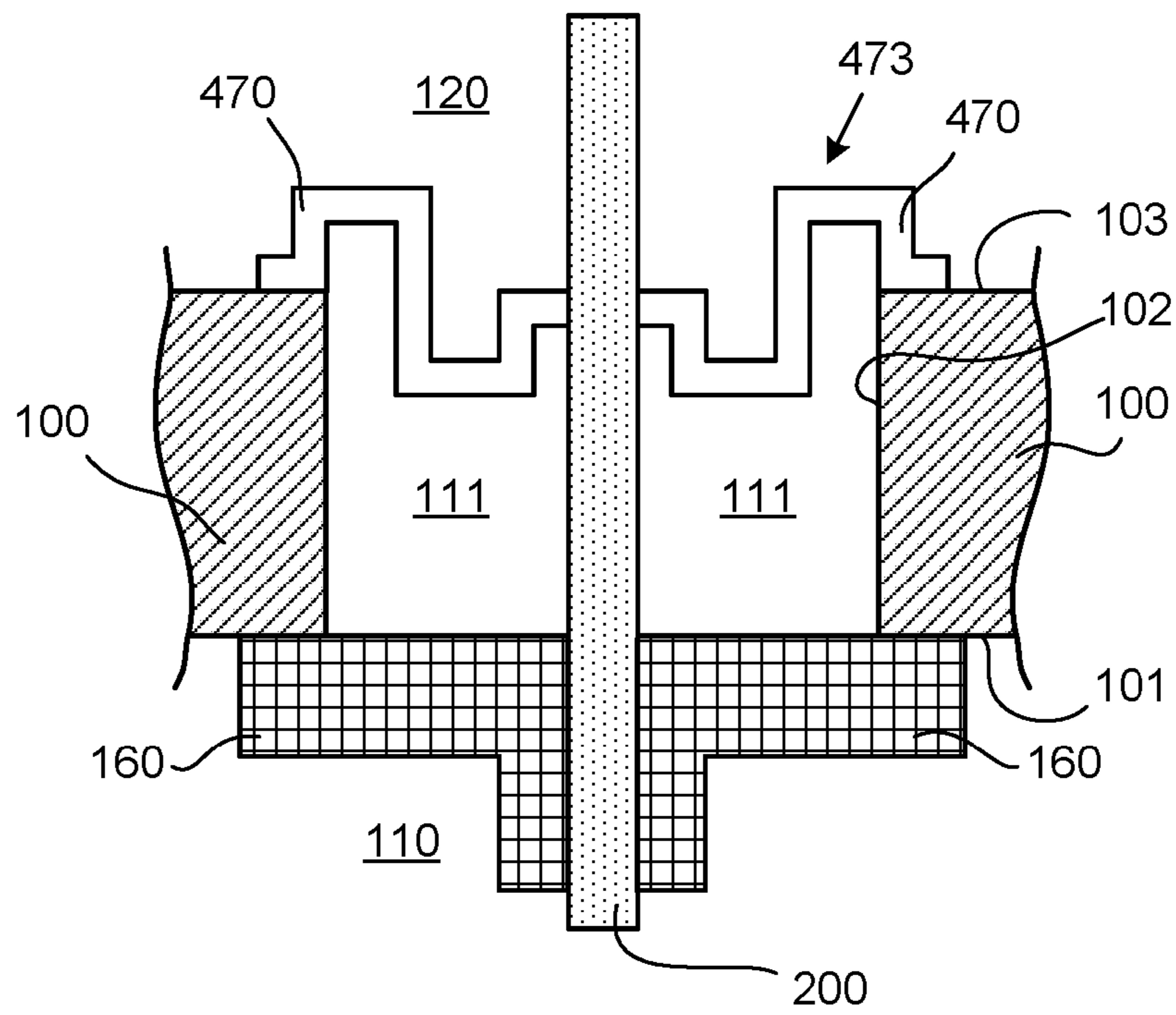

Fig. 4C

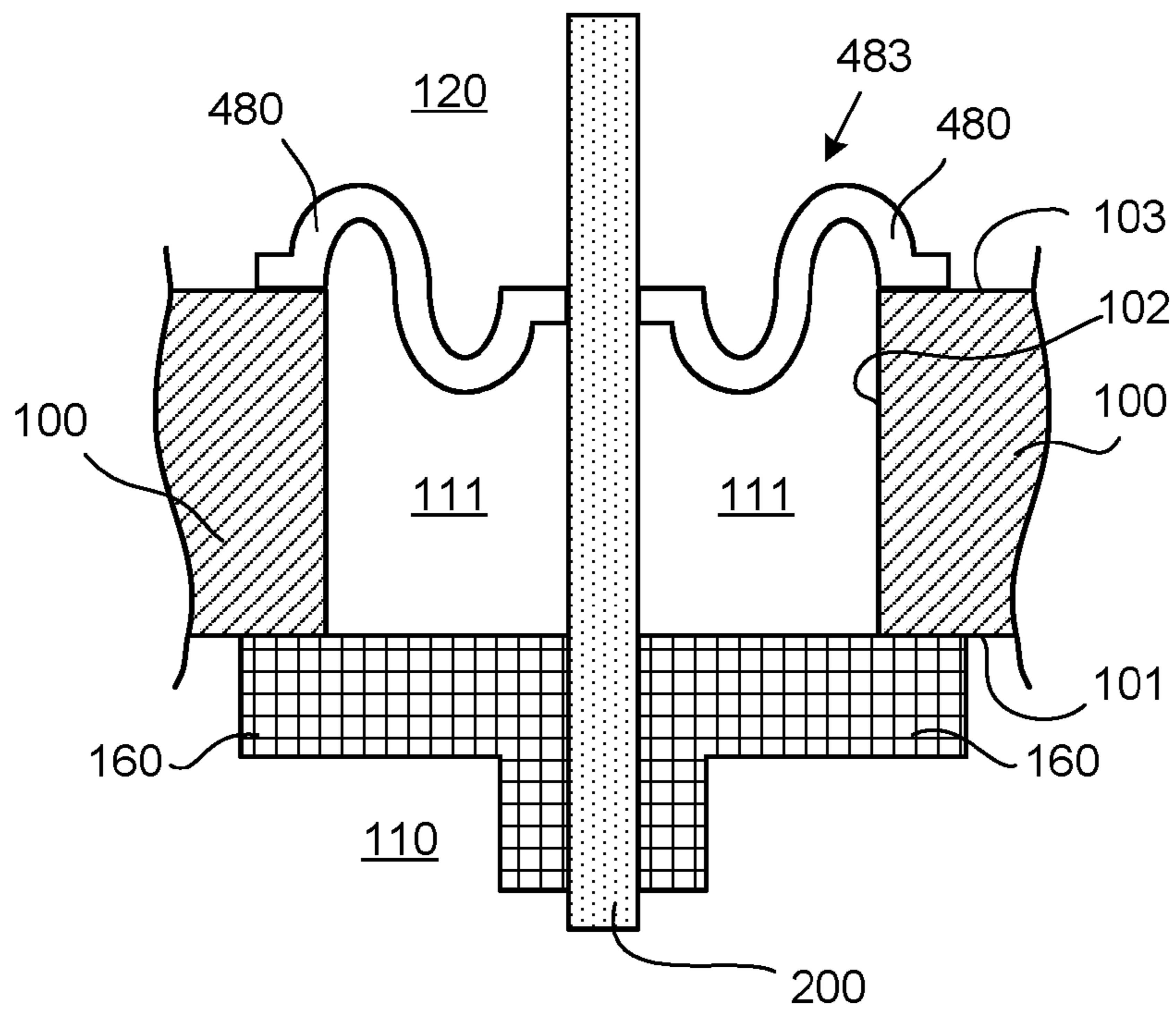

Fig. 4D

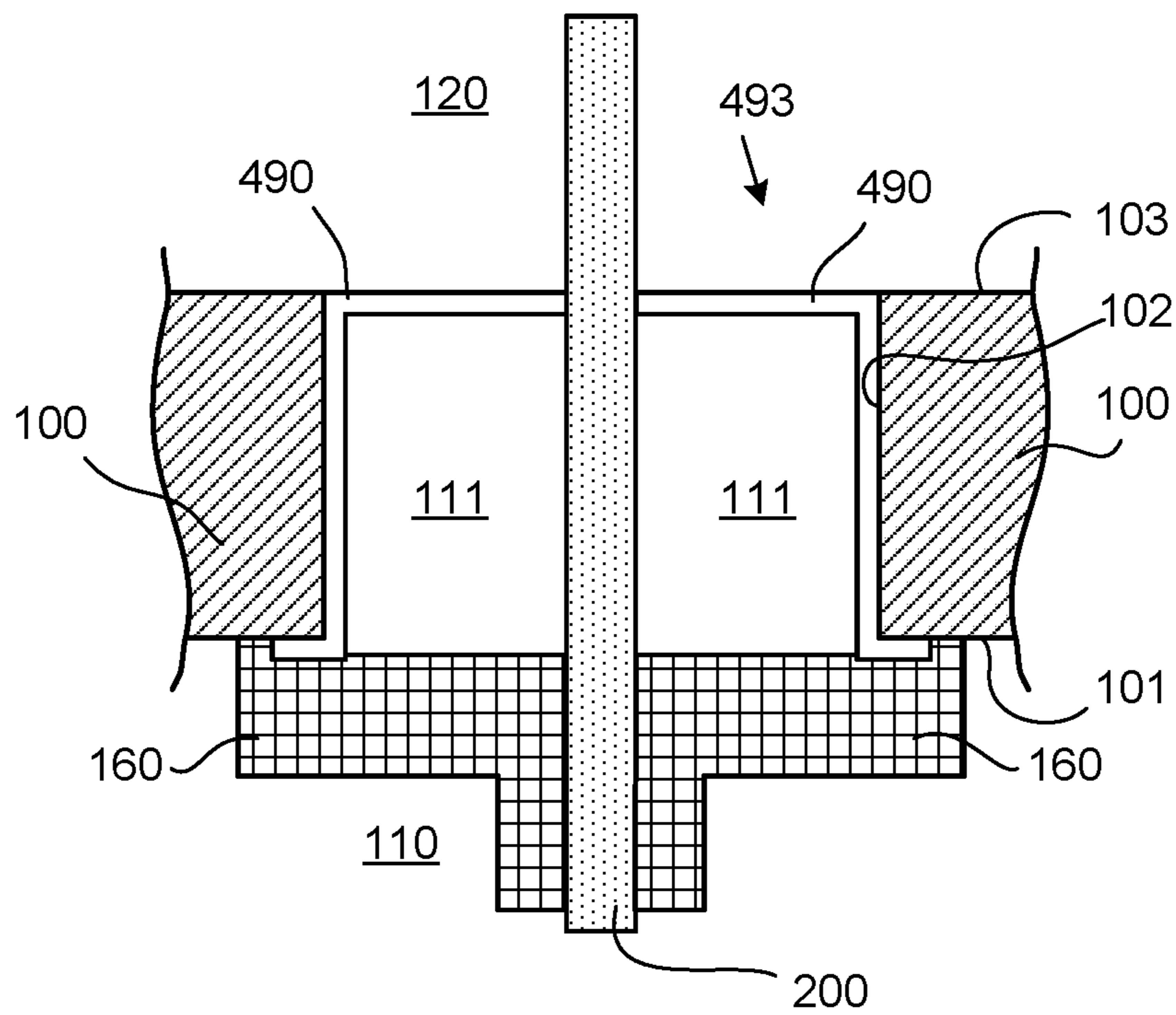

Fig. 4E

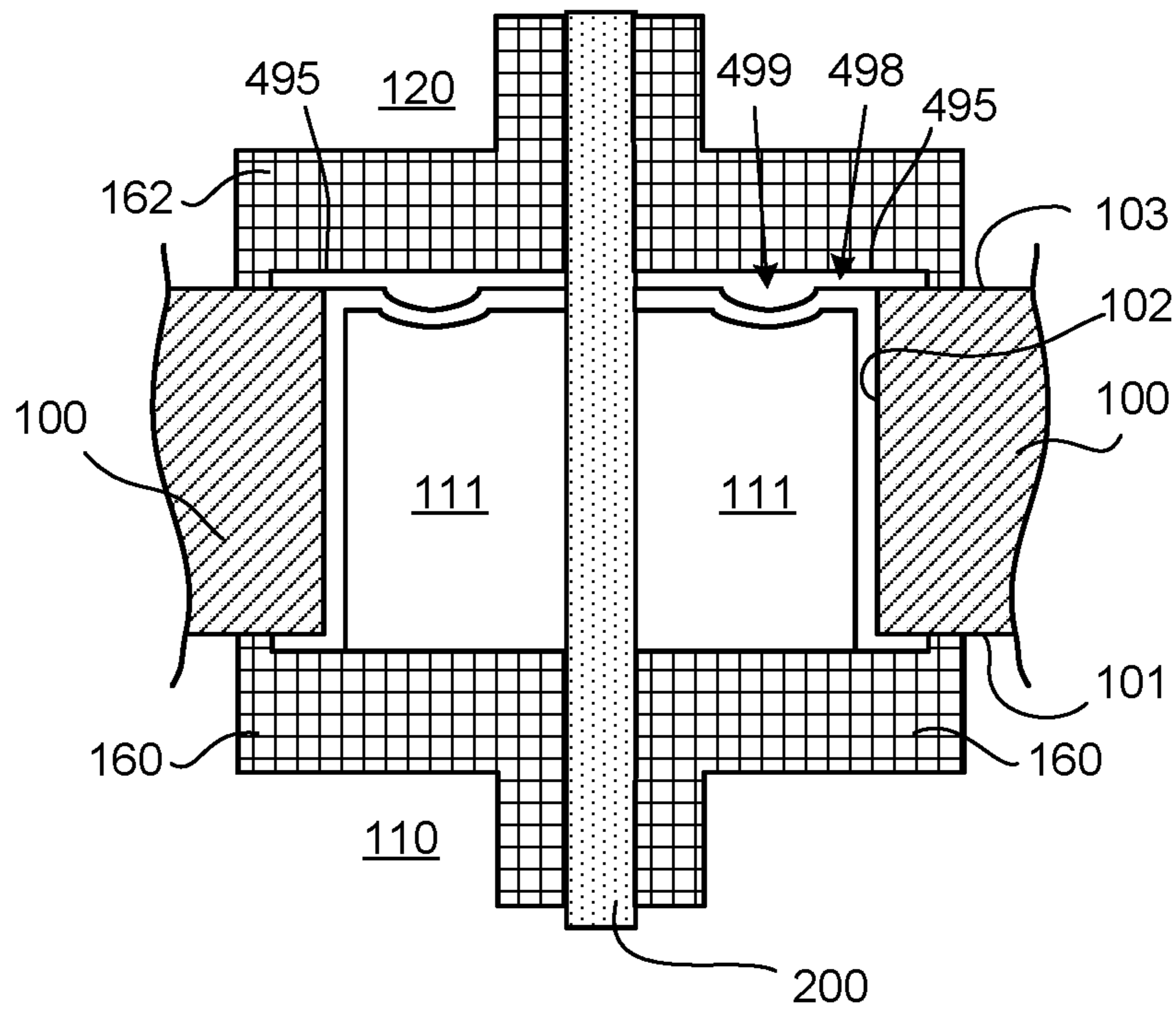

Fig. 4F

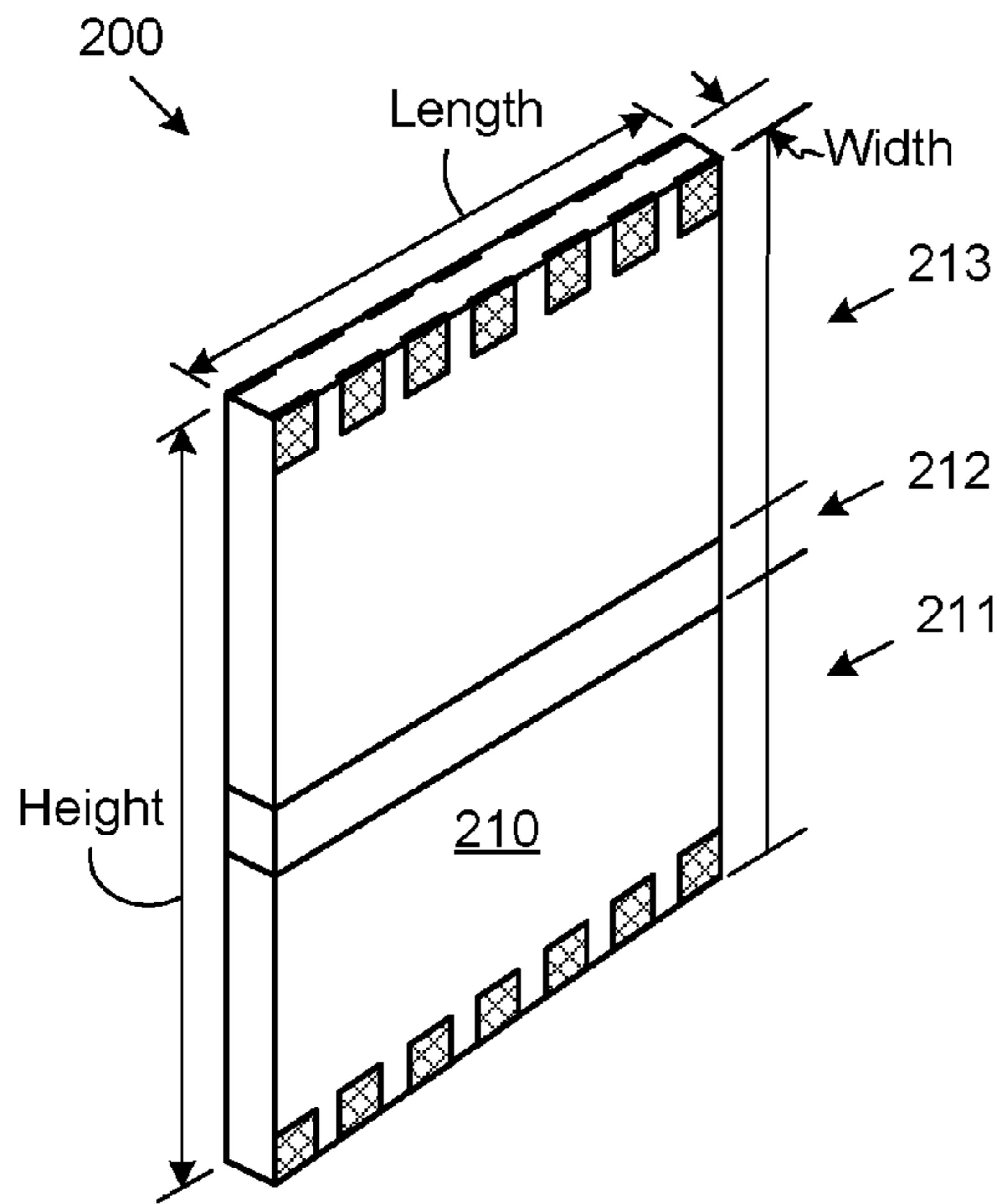

Fig. 5A

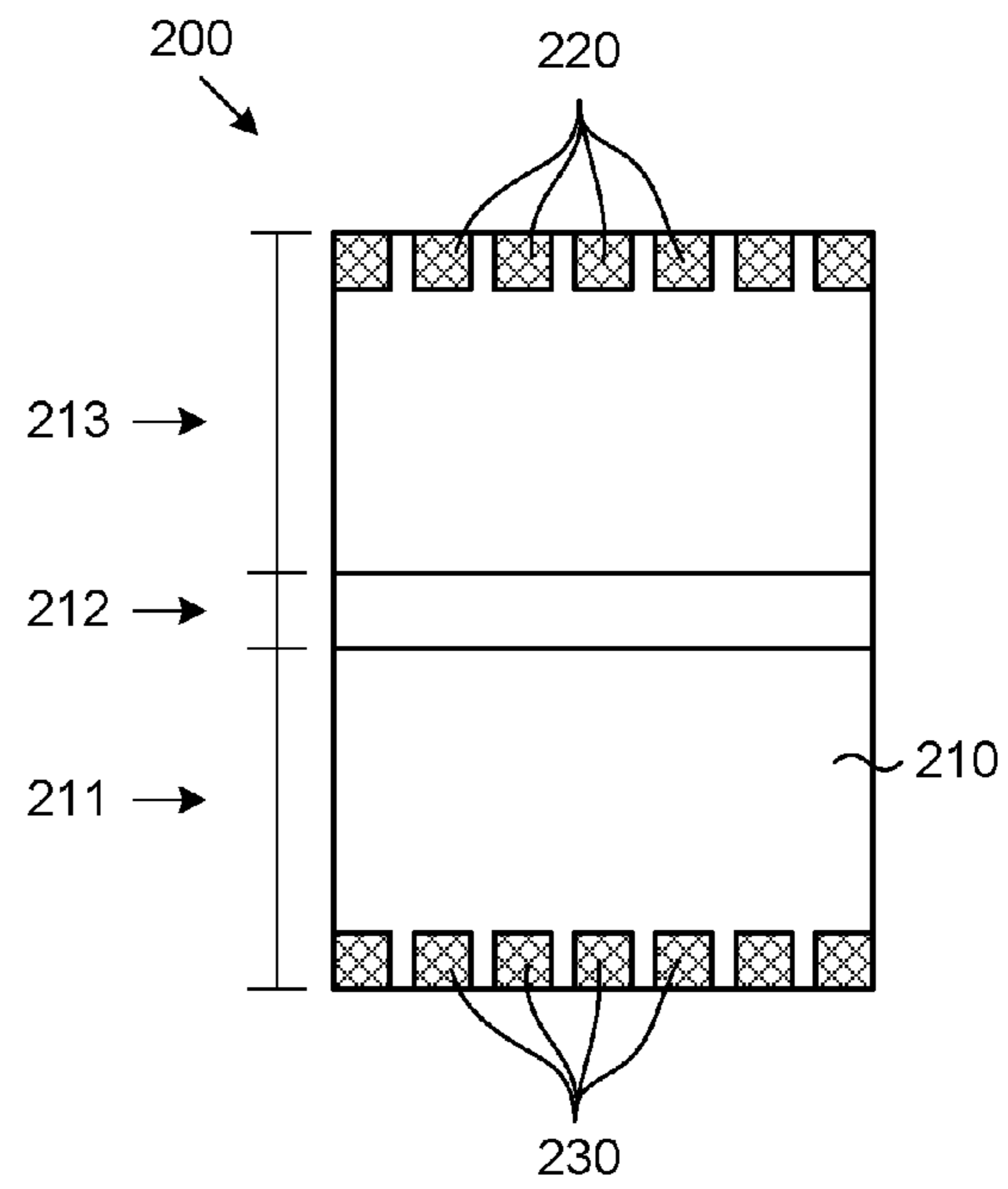

Fig. 5B

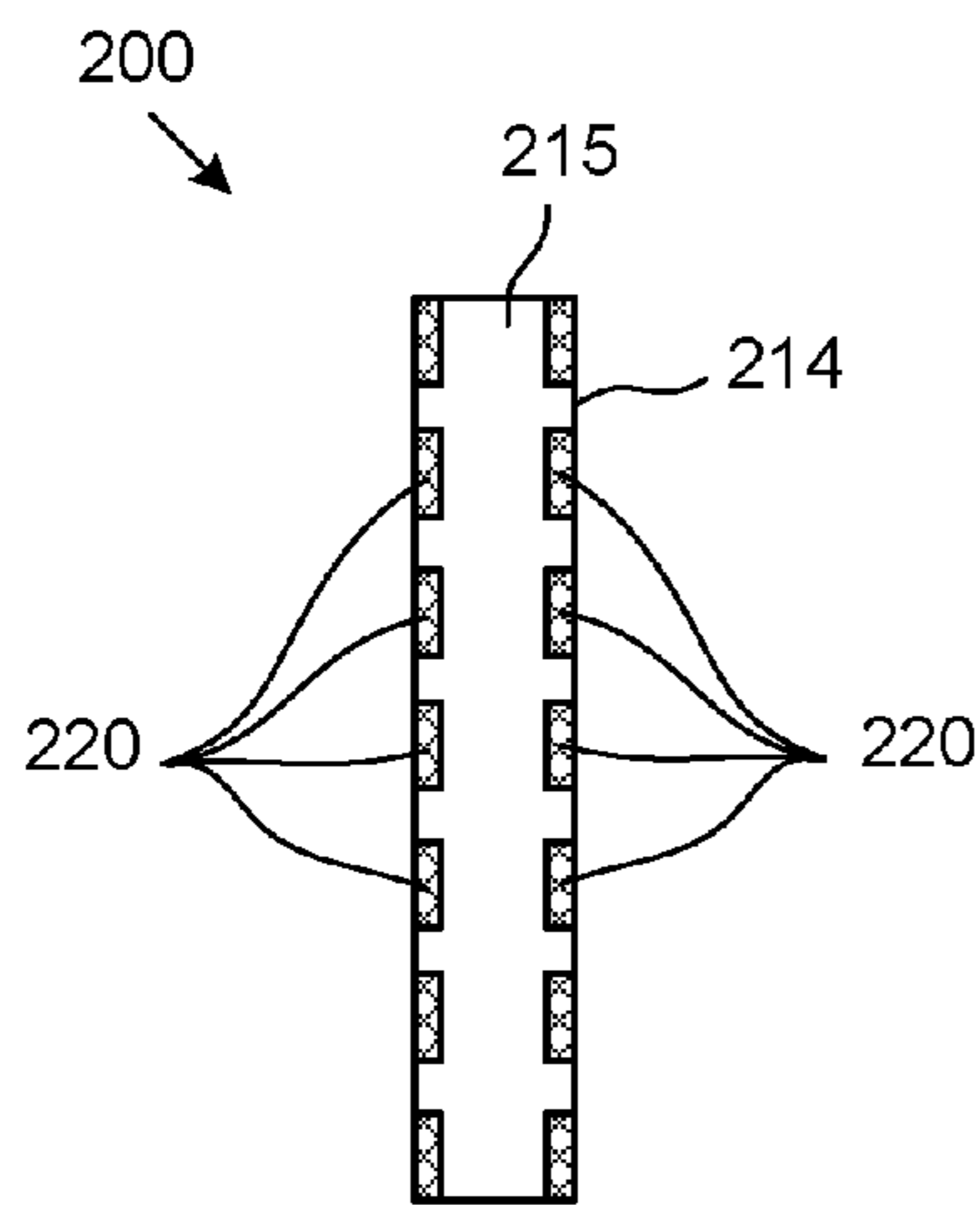

Fig. 5C

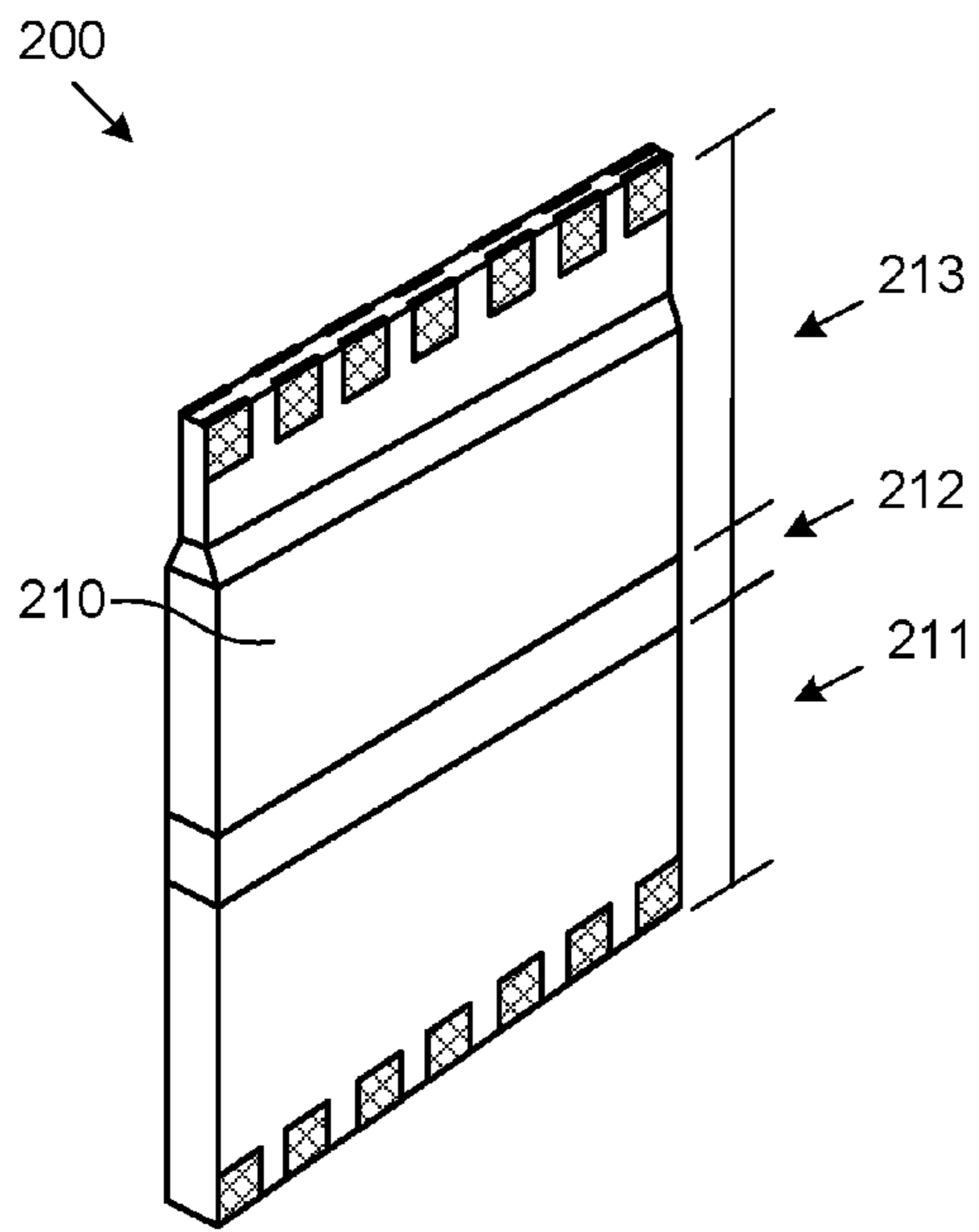

Fig. 6A

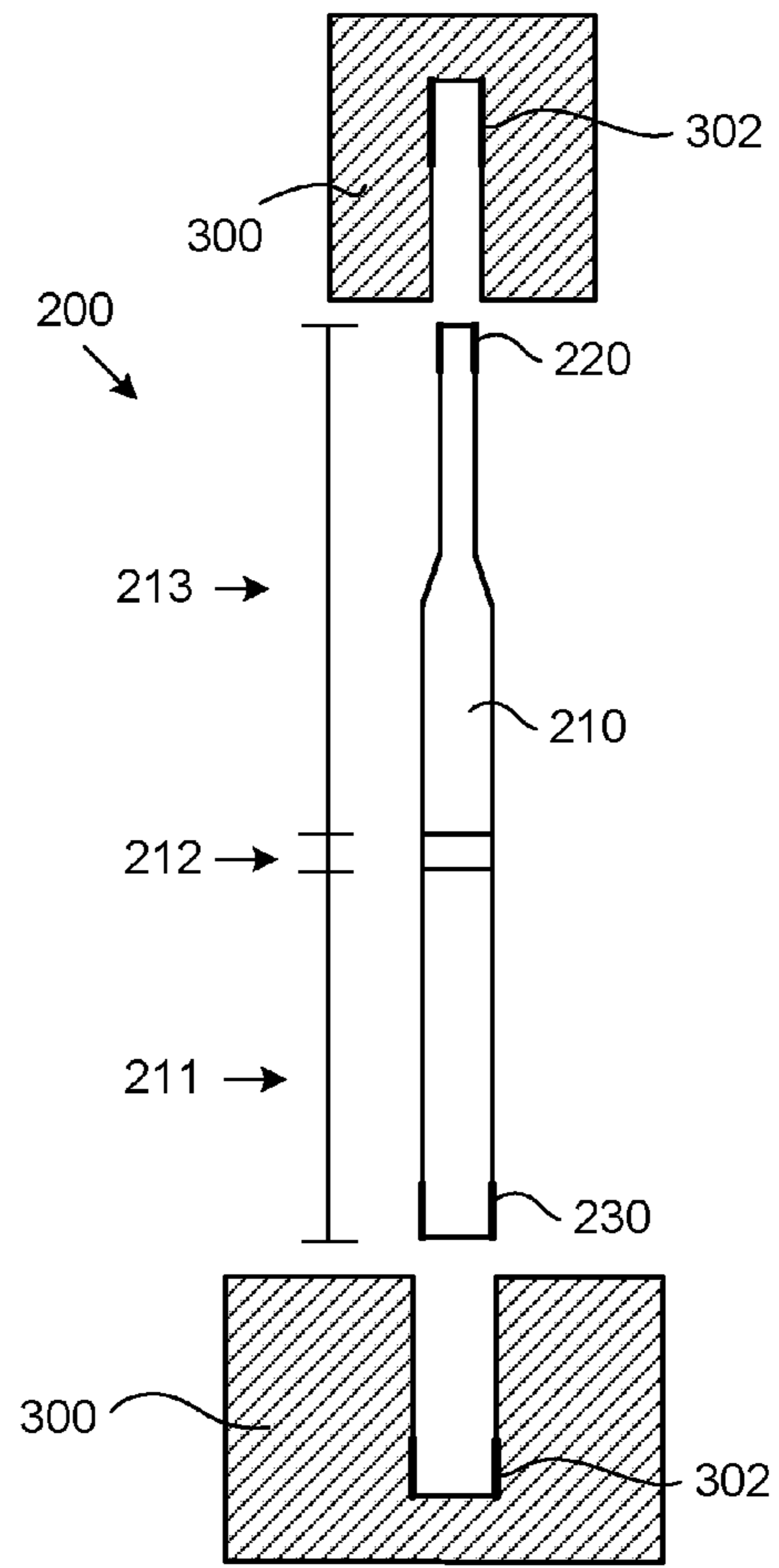

Fig. 6B

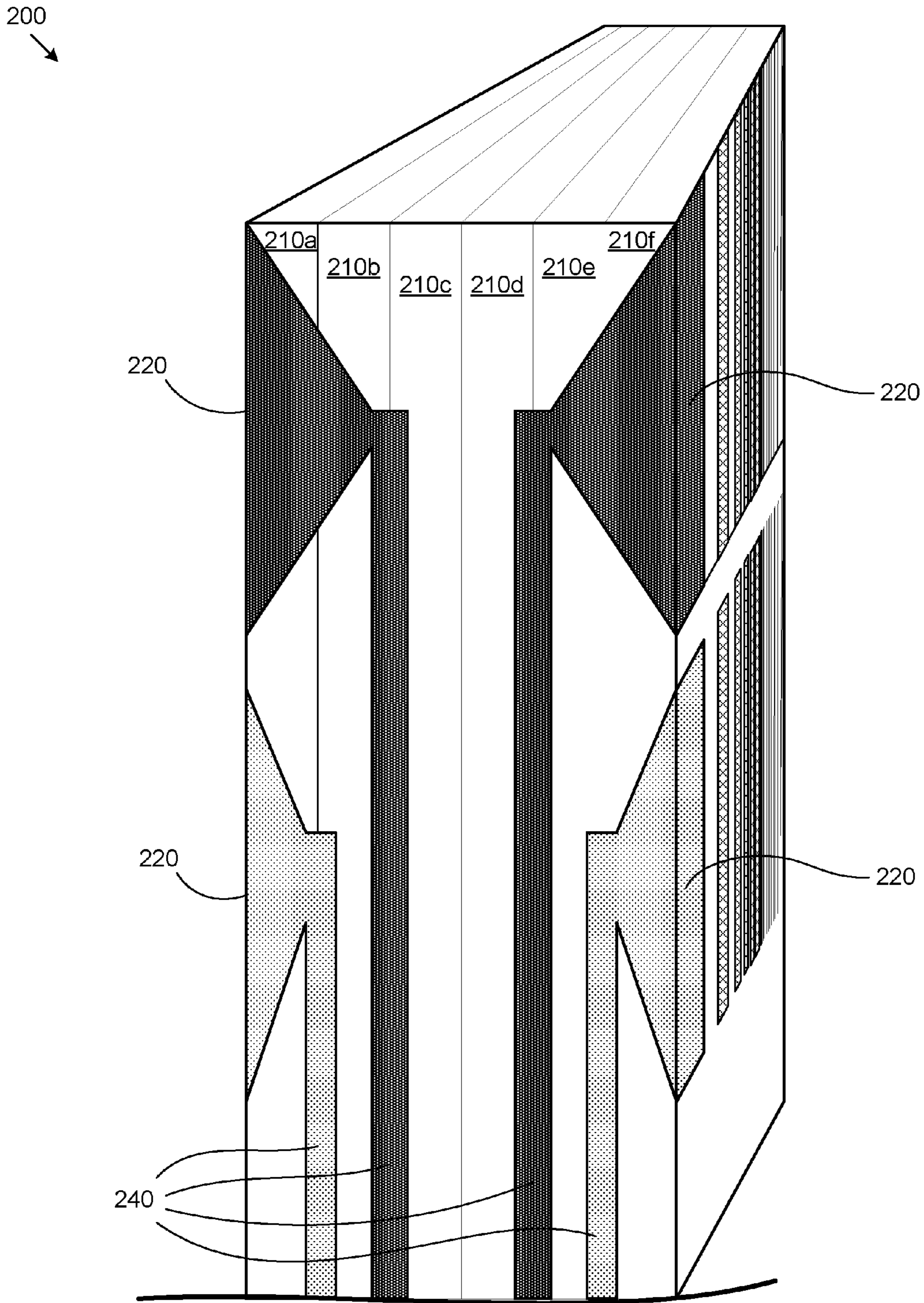

Fig. 7

1

FEEDTHROUGH CONNECTOR FOR HERMETICALLY SEALED ELECTRONIC DEVICES

FIELD

This disclosure relates generally to electrical connectors for electronic devices, and more particularly to feedthrough electrical connectors for hermetically sealed electronic devices.

BACKGROUND

Hard disk drives are commonly used for storing and retrieving digital information using rapidly rotating discs or platters coated with magnetic material. Digital information is transferred between a hard disk drive and a computing device by virtue of an electrical connector forming part of the hard disk drive. Conventional electrical connectors include non-feedthrough connectors (e.g., P2 connectors) and feedthrough connectors.

Feedthrough connectors are defined by a plurality of electrical connections extending from outside the housing of an electronic device, such as a hard disk drive, to within an interior cavity of the electronic device. The portion of the electrical connections external to the housing are electrically coupled to a mating electrical connector of a computing device, while the portion of the electrical connections internal to the housing are electrically coupled to various components within the interior cavity.

Conventional feedthrough connectors are often difficult to couple to the housing of an electronic device, especially in circumstances where the interior cavity of the housing is sealed and maintained at a certain condition (e.g., pressure, temperature, air composition, etc.). For example, certain hard disk drives greatly benefit from a housing that isolates the interior cavity and the contents of the hard disk drive from the atmosphere exterior to the housing.

Further, conventional feedthrough connectors often experience severe and repeated mechanical stress caused by thermal cycling of the feedthrough connectors. In other words, different materials often utilized in forming and sealing the feedthrough connector within a feedthrough aperture of a hermetically sealed chamber have different coefficients of thermal expansion. Such non-uniformity of thermal expansion between components may impart mechanical stress and strain to the components, especially at the joints between components of the feedthrough connector assembly. Mechanical stress and strain can cause cracks and/or fractures to form in the feedthrough connector assembly, which may jeopardize the integrity of the hermetically sealed environment.

Some conventional solutions involve utilizing materials that have similar coefficients of thermal expansion, which may decrease the mechanical stress and strain caused by repeated thermal cycling. However, the manufacturing processes associated with the use of materials with matching coefficients of thermal expansion tend to significantly increase the cost of manufacturing and materials.

SUMMARY

The subject matter of the present application has been developed in response to the present state of the art, and in particular, in response to the problems and needs associated with hard disk drives and associated electrical connectors that have not yet been fully solved by currently available

2

systems. Accordingly, the subject matter of the present application has been developed to provide a feedthrough electrical connector, and associated apparatus, systems, and methods, that overcomes at least some of the above-discussed shortcomings of the prior art.

Disclosed herein is one embodiment of an apparatus that includes a housing that defines an interior cavity. The housing also includes a spring aperture. The apparatus further includes a spring coupled to the housing over the spring aperture, with the spring having a deflection portion and a feedthrough aperture. The apparatus has an electrical connector coupled to the spring and extending through the feedthrough aperture and the spring aperture. The electrical connector may have a plurality of electrical traces extending from a location external to the housing to a location within the interior cavity of the housing.

According to one implementation, the electrical connector is exclusively indirectly coupled to the housing via the spring. According to another implementation, the apparatus further includes at least one support bracket coupled to the housing, with the at least one support bracket being in supporting engagement with the electrical connector. The electrical connector may be exclusively indirectly coupled to the housing via the spring and the at least one support bracket. According to another implementation, the deflection portion of the spring absorbs thermal expansion of the electrical connector. In one implementation, the deflection portion extends entirely around the feedthrough aperture. The deflection portion may form a rectangular footprint or an oval footprint, among other shapes, or the deflection portion may include multiple deflection portions. In another implementation, the spring may be directly coupled to an external surface of the housing and/or a sidewall of the spring aperture of the housing. In one implementation, a seal between the spring and the housing maintains the interior cavity as a hermetically sealed environment. For example, the interior cavity may contain a helium-enriched environment and the seal may include one or more of solder, adhesive, and epoxy, with the epoxy having a low helium permeability.

Disclosed herein is another embodiment of an apparatus that includes a housing that defines an interior cavity. The housing also includes a spring aperture. The apparatus further includes a spring coupled to the housing over the spring aperture, with the spring having a deflection portion and a feedthrough aperture. The apparatus further includes an electrical connector coupled to the spring and extending through the feedthrough aperture and the spring aperture. The electrical connector has a plurality of electrical traces extending from a location external to the housing to a location within the interior cavity of the housing. The electrical connector further includes an electrically insulating base that has multiple layers of electrically insulating material with the plurality of electrical traces extending between the multiple layers. The electrically insulating base includes an inwardly positioned portion disposed in the interior cavity, an outwardly positioned portion disposed external to the interior cavity, and a sealing portion disposed between the inwardly positioned portion and the outwardly positioned portion, with the sealing portion being sealed to the feedthrough aperture of the spring. The electrical connector further includes a first plurality of electrical leads disposed on the outwardly positioned portion of the electrically insulating base and a second plurality of electrical leads disposed on the inwardly positioned portion of the electrically insulating base. Each electrical lead of the first plurality of electrical leads is electrically coupled to a

3

respective electrical lead of the second plurality of electrical leads via the electrical traces.

According to one implementation, the electrical connector is exclusively indirectly coupled to the housing via the spring. In another implementation, the apparatus further includes at least one support bracket coupled to the housing, with the at least one support bracket being in supporting engagement with the electrical connector. The electrical connector may be exclusively indirectly coupled to the housing via the spring and the at least one support bracket. The deflection portion of the spring may absorb the thermal expansion of the electrical connector.

Further disclosed herein is one embodiment of a hard disk drive that includes a hermetically sealed housing that substantially isolates a hard drive cavity containing a helium enriched environment from an exterior atmosphere, with the housing having a spring aperture. The hard disk drive further includes a spring coupled to the hermetically sealed housing over the spring aperture and the spring has a deflection portion and a feedthrough aperture.

The hard disk drive may further include an electrical connector coupled to the spring and extending through the feedthrough aperture and the spring aperture. The electrical connector has a plurality of electrical traces extending from a location external to the hermetically sealed housing to a location within the interior cavity of the hermetically sealed housing. The electrical connector may include an electrically insulating base that has multiple layers of electrically insulating material with the plurality of electrical traces extending between the multiple layers. The electrically insulating base includes an inwardly positioned portion disposed in the interior cavity, an outwardly positioned portion disposed external to the interior cavity, and a sealing portion disposed between the inwardly positioned portion and the outwardly positioned portion, with the sealing portion being sealed to the feedthrough aperture of the spring. Further, the electrical connection includes a first plurality of electrical leads disposed on the outwardly positioned portion of the electrically insulating base and a second plurality of electrical leads disposed on the inwardly positioned portion of the electrically insulating base, with each electrical lead of the first plurality of electrical leads being electrically coupled to a respective electrical lead of the second plurality of electrical leads via the electrical traces.

The hard disk drive may further include at least one support bracket coupled to the hermetically sealed housing. The at least one support bracket is in supporting engagement with the electrical connector and the electrical connector is exclusively indirectly coupled to the hermetically sealed housing via the spring and the at least one support bracket.

The described features, structures, advantages, and/or characteristics of the subject matter of the present disclosure may be combined in any suitable manner in one or more embodiments and/or implementations. In the following description, numerous specific details are provided to impart a thorough understanding of embodiments of the subject matter of the present disclosure. One skilled in the relevant art will recognize that the subject matter of the present disclosure may be practiced without one or more of the specific features, details, components, materials, and/or methods of a particular embodiment or implementation. In other instances, additional features and advantages may be recognized in certain embodiments and/or implementations that may not be present in all embodiments or implementations. Further, in some instances, well-known structures, materials, or operations are not shown or described in detail

4

to avoid obscuring aspects of the subject matter of the present disclosure. The features and advantages of the subject matter of the present disclosure will become more fully apparent from the following description and appended claims, or may be learned by the practice of the subject matter as set forth hereinafter.

BRIEF DESCRIPTION OF THE DRAWINGS

In order that the advantages of the subject matter may be more readily understood, a more particular description of the subject matter briefly described above will be rendered by reference to specific embodiments that are illustrated in the appended drawings. Understanding that these drawings depict only typical embodiments of the subject matter and are not therefore to be considered to be limiting of its scope, the subject matter will be described and explained with additional specificity and detail through the use of the drawings, in which:

FIG. 1 is a perspective view of a hard disk drive with a feedthrough electrical connector coupled to a spring, according to one embodiment;

FIG. 2 is a cross-sectional side view of a hard disk with a feedthrough electrical connector coupled to a spring, according to one embodiment;

FIGS. 3A-3C are top partial views of a feedthrough electrical connector extending through a hermetically sealed chamber housing showing various embodiments of spring footprints of springs coupled to the housing;

FIGS. 4A-4F are partial cross-sectional side views of a feedthrough electrical connector extending through a hermetically sealed chamber housing showing various embodiments of deflection portions of springs coupled to the housing;

FIG. 5A is a perspective view of a feedthrough electrical connector according to one embodiment;

FIG. 5B is a front view of the feedthrough electrical connector of FIG. 5A;

FIG. 5C is a top view of the feedthrough electrical connector of FIG. 5A;

FIG. 6A is a perspective view of a feedthrough electrical connector according to another embodiment;

FIG. 6B is a side view of the feedthrough electrical connector of FIG. 6A with corresponding electrical contacts according to one embodiment; and

FIG. 7 is a magnified cross-sectional perspective view of a feedthrough electrical connector according to one embodiment.

DETAILED DESCRIPTION

Reference throughout this specification to “one embodiment,” “an embodiment,” or similar language means that a particular feature, structure, or characteristic described in connection with the embodiment is included in at least one embodiment of the present disclosure. Appearances of the phrases “in one embodiment,” “in an embodiment,” and similar language throughout this specification may, but do not necessarily, all refer to the same embodiment. Similarly, the use of the term “implementation” means an implementation having a particular feature, structure, or characteristic described in connection with one or more embodiments of the present disclosure, however, absent an express correlation to indicate otherwise, an implementation may be associated with one or more embodiments.

Referring to FIGS. 1 and 2, a hard disk drive **10** with a feedthrough electrical connector **200** and a spring **150** is

5

shown according to one embodiment. The hard disk drive **10** includes a housing **100** that defines an interior cavity **110**. The interior cavity **110** contains hard disks and other interior components **112** of the hard disk drive **10**. In one embodiment, the feedthrough electrical connector **200** includes an electrically insulating base **210** with a plurality of electrical leads **220** disposed on at least one peripheral surface of the electrically insulating base **210** and a plurality of corresponding electrical traces (not shown) extending through the electrically insulating base. In another embodiment, the electrical connector includes a plurality of pins (traces) extending through the electrically insulating base and a skirt positioned about a periphery of the electrically insulating base. Generally, the feedthrough electrical connector **200** electrically connects the interior components **112** of the hard disk drive with a computing device (not shown), while still maintaining the interior cavity **110** of the hard disk drive relatively isolated from the exterior atmosphere **120**. Additional details relating to the feedthrough electrical connector **200** are included below with reference to FIGS. 2-7.

Although the illustrated embodiments described below are in relation to a hard disk drive with an electrical connector, in other embodiments, the principles and features of the present disclosure can be applied to other electronic devices that could benefit from a feedthrough electrical connector, such as solid state memory devices, semiconductor devices, general computing devices, and the like.

The housing **100** of the hard disk drive **10** houses and protects the various internal components **112** configured to store and retrieve data and information, as well as to control the storage and retrieval of data and information. The components **112** within the interior cavity **110** may include magnetic recording media (e.g., disks), read/write heads, actuators (e.g., swings arms), electrical circuitry, and the like. The hard disk drive **10** can be in electrical communication with a computing device (not shown) to transfer data for operation of the computing device. In one embodiment, the housing **100** is configured to hermetically seal the components **112** of the hard disk drive **10** from the exterior environment **120**. In certain implementations, the housing **100** includes two or more sections coupled together to maintain the sealing nature of the housing. According to some implementations, the housing **100** maintains the interior cavity **110** of the housing of the hard disk drive **10** at a pressure below atmospheric pressure. Because the components of hard disk drives, according to one embodiment, are sensitive to contaminants and pressure changes, hermetically sealing the internal components **112** of the hard disk drive **10** from the exterior environment **120** promotes the proper operation of the hard disk drive **10** and also extends the life of the hard disk drive **10**.

The housing **100**, which can be made from any of various materials (such as hardened plastics, metal, and the like), may, in certain embodiments, include a connector receptacle **130**. The connector receptacle **130** is formed in an exterior surface of the housing **100** about a spring aperture **135** (see FIG. 2), which is also formed in the housing **100**. The spring aperture **135**, in the absence of the spring **150** and the feedthrough electrical connector **200**, is open to the interior cavity **110** of the hard disk drive **10**. Generally, the connector receptacle **130** may be configured to receive and orient mating electrical connectors that are connectable with the electrical connector **200**. Although shown in FIG. 1 as a tray or indentation in the housing **100** that is substantially larger than the connector **200** and larger than the spring **150**, in other embodiments, the connector receptacle **130** may be sized similar to the electrical connector **200** in order to

6

physically support the spring **150** or the protruding surfaces of the electrical connector **200**. Further, the connector receptacle **130** may be useful for retaining a layer of solder, adhesive, or other weldment agent for securing the spring **150** to the housing **100**. Further details regarding the spring **150** and the electrical connector **200** are included below.

FIG. 2 is a schematic cross-sectional side view of a hard disk drive **10** with the feedthrough electrical connector **200** and the spring **250**, according to one embodiment. In the depicted embodiment, the hard disk drive **10** includes a housing **100** that substantially isolates the interior cavity **110** of the hard disk drive **10** from the exterior atmosphere **120**. For example, the interior cavity **110** may have a helium enriched atmosphere or the interior cavity **110** may be maintained at a lower pressure than the pressure of the exterior atmosphere **120**. Certain hard disk drives **10** are specifically configured to have or maintain certain conditions within the interior cavity **110** to promote the efficient operation of the hard disk drive **10**. Leaks from the housing tend to disrupt the desired conditions within the interior cavity (e.g., cause an increase in pressure or introduction of heavier air), which can harm the efficiency and reliability of the hard disk drive **10**.

The embodiment of the housing **100** depicted in FIG. 2 does not include a connector receptacle **130** (as depicted in FIG. 1). The housing **100** holds the components **112** of the hard disk drive, such as magnetic media and read/write arms. Also depicted schematically in the interior cavity **110** of the hard disk drive **10** are secondary electrical connections **114** that electrically connect the components **112** of the hard disk drive **10** to the feedthrough electrical connector **200**. The secondary electrical connections **114** may be wiring, electrical traces, connectors, controllers, control modules, and the like. Such secondary electrical connections **114** may be configured to connect with the feedthrough electrical connector **200** in a variety of ways, as recognized by those of ordinary skill in the art.

The spring **250**, which may be constructed of a metallic material, a plastic material, a polymeric material, or a composite material, among others, is coupled to the housing **100** and extends over and at least partially across the spring aperture **135**. The spring aperture **135** is an aperture formed in the wall of the housing **100** that is wider than the cross-sectional dimensions of the electrical connector **200**. The spring **250** may be directly coupled to the housing via any of various coupling techniques, such as techniques using solder, adhesive, or epoxy, among others. Additional details relating to the spring **250** are included below with reference to FIGS. 3A-4F. Generally, the spring **250** includes a feedthrough aperture **254** through which the electrical connector **200** extends and to which the electrical connector **250** is directly coupled. The coupling of the spring **250** to the housing **100** (across the spring aperture **135**) and the coupling of the electrical connector **200** within the feedthrough aperture **254** creates a hermetic seal that isolates the interior cavity **110** from the exterior atmosphere **120**. In other words, in one embodiment the electrical connector **200** is indirectly coupled to the housing **100** via the spring **250**. In such an embodiment, direct engagement or contact between the electrical connector **200** and the housing, if any, is not contributing to the hermetic seal.

The spring **250** includes a deflection portion **253** that helps to absorb thermal expansion of the electrical connector **200** relative to the housing **100** caused by thermal cycling (i.e., operation of the feedthrough connector). The deflection portion **253**, according to one embodiment, is a bend, curve, twist, or bow in the spring. As will be described in greater

detail below with reference to FIGS. 3A-4F, the deflection portion 253 compresses and expands as the electrical connector 200 thermally expands and compresses, respectively. In other words, the deflection portion 253 dampens and/or dissipates thermal or other expansion of the electrical connector 200, thus helping to maintain the hermetic seal.

According to one embodiment, the feedthrough electrical connector 200 includes an electrically insulating base 210 and a plurality of electrical leads 220. The electrically insulating base 210 may include multiple layers of electrically insulating material with electrical traces extending between adjacent layers. For example, the multiple layers may extend in a direction perpendicular to the cross-sectional area of the feedthrough aperture 254. The electrically insulating base 210 also includes three different portions or sections: an inwardly positioned portion 211, a sealing portion 212, and an outwardly positioned portion 213. Although described and referenced throughout the disclosure as three separate portions 211, 212, 213, it is contemplated that, according to one embodiment, the electrically insulating base 210 may be a single, integrated structure. In other embodiments, the electrically insulating base 210 may be modular such that each portion 211, 212, 213 is a separate material. Further, in one embodiment, the electrically insulating base 210 may be layered (FIG. 7). Additional details regarding the structure and composition of the electrically insulating base 210 are included below with reference to FIGS. 5A and 7.

In one embodiment, the feedthrough electrical connector 200 has at least a first plurality of electrical leads 220 on the outwardly positioned portion 213. The first plurality of electrical leads 220 may be disposed on at least one peripheral surface of the outwardly positioned portion 213. The arrangement, material, and structure of the leads 220 are described in greater detail below with reference to FIG. 5A-7. The first plurality of electrical leads 220 are electrically connected, via electrical traces/wires not depicted in FIG. 2, to corresponding contact points on the inwardly positioned portion 211 of the electrically insulated base material 210 for connecting with the components 112 of the hard disk drive 10.

Although described in greater detail below, the inwardly positioned portion 211 of the electrically insulating base 210 of the feedthrough electrical connector 200 may or may not have similarly situated electrical leads. For example, in one embodiment, the secondary electrical connections 114 may electrically connect to the electrical connector 200 via leads disposed on the inwardly positioned portion 211 of the electrically insulating base 210. However, in another embodiment, the inwardly positioned portion of the electrically insulating base 210 may resemble a conventional electrical connector that has electrical contact points for interfacing with the integrated wiring 114 and components 112 of the hard disk drive 10.

The sealing portion 212 is the portion/region of the feedthrough electrical connector 200 that engages the feedthrough aperture 254 and couples the connector 200 to the spring 250. In one embodiment, the sealing portion 212 is electroplated with a soldering metal or other weldment facilitator for coupling the connector 200 to the spring 250. In another embodiment, the sealing portion 212 couples to the feedthrough aperture 254 via an adhesive composition. Additional details relating to the sealing portion 212 are included below with reference to FIG. 5A.

In one embodiment, the feedthrough electrical connector 200 has a first plurality of electrical leads 220 disposed on a distal end of the outwardly positioned portion 213 of the

electrically insulating base 210. These leads 220 are configured to be inserted into a corresponding/mated receptacle. For example, the outwardly positioned portion 213 of the connector 200 may be a zero-insertion-force type of connector. In another embodiment, the feedthrough electrical connector 200 may have a first plurality of electrical leads 220 disposed on a distal end of the outwardly positioned portion of the electrically insulating base 210.

FIGS. 3A-3C are top partial views of the feedthrough electrical connector 200 extending through the hermetically sealed chamber housing 100 showing various embodiments of spring footprints of springs coupled to the housing 100. As described above, the spring extends across the spring aperture 135 in the housing 100. Also as described above, the spring includes a deflection portion that facilitates absorbing thermal expansion of the electrical connector 200 caused by thermal cycling and thermal fluctuations. As described below with reference to FIGS. 4A-4F, the deflection portion may have the form of an outwardly and/or inwardly oriented bend, bow, trench, or curve.

FIG. 3A shows a spring 350 that includes a deflection portion 353 that has a rectangular spring footprint 352. The term spring footprint is defined herein as the pattern of the deflection portion across the surface of the spring. In other words, the term spring footprint refers to the relative configuration and orientation of the deflection portion with respect to the feedthrough aperture (or electrical connector). As depicted in FIG. 3A, the deflection portion 353 extends 360 degrees around the electrical connector 200 in a rectangular pattern. FIG. 3B shows a spring 360 with a deflection portion 363 that extends completely around the electrical connector 200 in an ovular (e.g., circular, elliptical, etc.) spring footprint 362. FIG. 3C shows yet another embodiment where the spring 370 includes a deflection portion 373 that does not extend completely around (i.e., does not completely circumscribe) the electrical connector 200. The deflection portion 373 may extend in straight lines, for example, along two sides of the electrical connector 200. In one embodiment, the deflection portion 373 extends along the two wider sides of the electrical connector 200 to absorb the out-of-plane thermal expansion of the electrical connector 200.

While the outer periphery of each of the springs 350, 360, 370 depicted in FIGS. 3A-3C is rectangular, it is expected that the outer peripheries of the springs may have other shapes, according to the specifics of a given application. For example, the outer periphery of a spring may form a square shape or a circular shape.

FIGS. 4A-4F are partial cross-sectional side views of the electrical connector 200 extending through the hermetically sealed chamber housing 100 showing various embodiments of deflection portions of springs coupled to the housing 100. FIG. 4A shows one embodiment of a spring 450 that is coupled to a sealing portion 212 of the connector 200. The sealing portion 212 is described in more detail below with reference to FIGS. 5A-B and 6A-B. The spring is also coupled to an outer surface 103 of the housing 100 and has a deflection portion 453 with a rectangular rib profile. The deflection portion 453 protrudes outwardly away from the space 111 of the spring aperture and is able to facilitate absorbing the mechanical/structural stress imparted to the apparatus by the thermal expansion of the electrical connector 200. As described above, the spring 450 may be coupled to the housing via soldering, weldment, epoxy, or adhesive, among others, in order to form a hermetic seal.

Also depicted in FIG. 4A is a support bracket 160 coupled to the inner surface 101 of the housing. However, the

support bracket **160**, according to one embodiment, does not provide a sealing engagement with the electrical connector **200** and thus does not contribute to the hermetic seal of the housing. In other words, the internal atmosphere of the interior cavity **110** may extend beyond the support bracket **160** and into the space **111** of the spring aperture, as shown in FIGS. 4A-4F. Accordingly, the support bracket **160** may be coupled to the housing **100** via fasteners and/or adhesives, among others. The support bracket **160** may be optionally included to provide mechanical reinforcement to the feedthrough connection. In one embodiment, as depicted in FIG. 4B, the feedthrough connector and the spring are implemented without a support bracket. While the spring **450** dampens the micro movement/vibration of thermal expansion, the support bracket **160** may be used to provide macro reinforcement. In other words, the support bracket **160** may be in non-sealing (e.g., supportive) engagement with the electrical connector **200**. The shape, size, orientation, and configuration of the support bracket **160** may be different than depicted in the figures of the present disclosure. Additionally, the support bracket **160** may also have electrical traces/leads and may be utilized to make electrical connections with other components.

FIG. 4B depicts a similar embodiment, only the spring **460** includes a deflection portion **463** that has a circular trench profile that indents inwardly. FIG. 4C shows a deflection portion **473** with a rectangular, wave-like trough profile. The deflection portion **473** of FIG. 4C may be considered a single deflection portion with two troughs facing in opposite directions. In another embodiment, the deflection portion **473** may consist of two separate, spaced apart deflection portions. In another embodiment, the spring may have multiple deflection portions spaced apart across the surface of the spring. FIG. 4D shows a deflection portion **483** with a circular, wave-like, trough profile.

FIG. 4E depicts a spring **490** that is directly coupled to the sidewalls **102** of the spring aperture of the housing **100**. The spring **490** also includes a lip that extends to engage the inner surface **101** of the housing **100**. The spring **490** depicted in FIG. 4E does not have a deflection portion formed in a portion of the spring **490** but instead the entire spring **490** effectively forms a large deflection portion **493**. FIG. 4F depicts an embodiment similar to FIG. 4E, but the spring **495** in FIG. 4F also includes an indentation that forms a deflection portion **499**. Also depicted in FIG. 4F is a second support bracket **162**. Similar to the support bracket **160** described above, the second support bracket **162** may provide additional supporting engagement to the electrical connector **200** and/or may include electrical contacts/traces for facilitating electrical connections with other electrical components. It is expected that the spring may be implemented in other manners not explicitly described herein and/or may be implemented by combining various aspects of the several embodiments described herein.

FIG. 5A is a perspective view of a feedthrough electrical connector **200** according to one embodiment. As described above, the feedthrough electrical connector **200** has an electrically insulating base **210** that defines the structure and overall shape of the connector **200**. The electrically insulating base **210** may be any non-conductive material that is suited for use in an electrical device. For example, the electrically insulating base **210** may be glass, ceramic, rubber, plastic, polymer, and the like. In one embodiment, the electrically insulating base **210** may be constructed in the same manner as printed circuit boards, printed wiring boards, etched wiring boards, printed circuit board assemblies, or circuit card assemblies. Although described in

greater detail below with reference to FIG. 7, the electrically insulating base **210** includes electrical traces for conveying electric current and electrical signals between the first plurality of electrical leads **220** and the second plurality of electrical leads **230**. In one embodiment, the electrically insulating base **210** implemented in the connector **200** may be selected according to the specific material's ability to withstand the conditions present in the interior cavity **110** of the hard disk drive **10**. For example, if a helium enriched atmosphere is maintained in the interior cavity **110**, an electrically insulating base **210** may be selected that has low helium permeability, thus promoting the isolation of the helium enriched interior cavity **110** from the exterior atmosphere **120**.

The three portions **211**, **212**, **213** of the electrically insulating base **210** are also depicted in FIG. 5A. As described above, the three portions **211**, **212**, **213** may be a single, integrated structure. In other embodiments, the electrically insulating base **210** may be modular such that each portion **211**, **212**, **213** is a separate material. In one embodiment, the portions **211**, **212**, **213**, may not be definitively marked and the portions may not be visually or structurally distinguishable from each other. In other words, the present disclosure distinguishes the portions **211**, **212**, **213** generally based on the expected arrangement and use of the feedthrough electrical connector **200**. For example, the outwardly positioned portion **213** may be comparatively more rigid and may be constructed of a stronger non-conductive material so as to withstand the conditions of the exterior atmosphere and/or repeated connecting and disconnecting (depending on the specifics of a given application). Also, the comparative lengths and relative dimensions of the three portions **211**, **212**, **213** are only illustrative of one embodiment and are not intended to restrict the scope of the disclosure. In other words, one portion may be substantially larger, longer, and/or wider than another portion, depending on the specifics of a given application. Also, as described below, the number, size, configuration, and arrangement of the depicted electrical leads **220**, **230** are not restrictive of the scope of the present disclosure. In one embodiment (as depicted) the width of electrically insulating base **210** is substantially smaller than the length and the height of the electrically insulating base **210**.

The sealing portion **212** may simply be a medial region where the connector **200** is coupled to the spring. However, in another embodiment the external surfaces of the sealing portion **212** may be electroplated with a soldering material. In another embodiment, the sealing portion **212** may include a prepared surface that is capable of bonding, through the use of an adhesive or epoxy, to the feedthrough aperture. In yet another embodiment, both an adhesive and solder (or other weldment agent) may be implemented to seal the connector **200** within the feedthrough aperture of the spring, thus substantially maintaining the interior cavity **110** isolated from the exterior atmosphere **120**. For example, in one embodiment, electroplating material may be disposed along the length of the sealing portion **212** and an adhesive may be disposed along the width of the sealing portion **212**. As briefly described above, the sealing portion **212** may not only be the region of the connector **200** that is directly engaged with the feedthrough aperture. In one embodiment, the sealing portion **212** may extend beyond the thickness of the feedthrough aperture of the spring. Once again, the adhesive and/or the solder may be selected according to its ability to withstand the expected conditions within the interior cavity **110** or the exterior atmosphere **120** (e.g., low helium permeability).

11

The electrically insulating base **210** may have a cross-sectional area, at least at the sealing portion, that is less than about 200 square millimeters. In a further embodiment, the cross-sectional area of the electrical connector may be less than about 100 square millimeters. In one embodiment, the electrical connector, at least in the sealing portion, has a cross-section that is co-planar with the cross-sectional area of the feedthrough aperture and that includes a first and second dimension. The first dimension, according to one embodiment, is substantially longer than the second direction. For example, the first dimension may be at least 5 times the length of the second dimension. In another implementation, the first dimension is at least 10 times the length of the second dimension.

FIG. 5B is a front view of the feedthrough electrical connector **200** of FIG. 5A, according to one embodiment. As described and shown in FIGS. 3 and 4, the electrical connector **200** has a first plurality of leads **220** disposed on the outwardly positioned portion **213** and a second plurality of leads **230** disposed on the inwardly positioned portion **211**. The first **220** and second plurality of leads **230** are interconnected via traces/wiring extending the length of the electrically insulating base **210** (see FIG. 7). As described above, the first plurality of electrical leads **220** are disposed on at least one peripheral surface of the outwardly positioned portion **213** of the connector **200**. However, the second plurality of electrical leads **230**, while they may be similar in arrangement and configuration to the first plurality of electrical leads **220** (as depicted in FIGS. 4 and 5A-5C), in another embodiment may have the structure and configuration of a conventional electrical connector (i.e., electrical terminals, electrical contacts, wire couplings, etc.).

The leads **220**, **230** may be constructed from any electrically conductive material that is suited for use in an electrical device. For example, the electrical leads **220**, **230** may be constructed of metals such as copper, aluminum, gold, zinc, nickel, brass, bronze, iron, platinum, etc. In another embodiment, the electrical leads **220**, **230** may be constructed of other conductive materials, such as graphite and conductive polymers. The number of leads in the first plurality of electrical leads **220** is not limited to the number depicted in the Figures. In one embodiment, the feedthrough electrical connector **200** may have less than 20 associated electrical leads. However, in another embodiment the feedthrough electrical connector **200** may have more than 20 associated electrical leads (i.e., hundreds or thousands) depending on the specifics of a given application.

FIG. 5C is a top view of the feedthrough electrical connector **200** of FIG. 5A, according to one embodiment. As depicted, the first plurality of electrical leads **220** may be disposed on opposing lateral peripheral sides **214** of the outwardly positioned portion **213** of the electrically insulating base **210**. Additionally, the electrical leads **220**, or at least a portion of the electrical leads **220**, may be exposed on the leading edge **215** of the connector **200**, thus allowing a mating connector to electrically engage the leads **220** on the peripheral sides **214** and/or the leading edge/surface **215** of the feedthrough connector **200**. Also, the first plurality of electrical leads **220** may be disposed on all the lateral sides **214** of the feedthrough connector **200** instead of just two opposing sides. In another embodiment, the leads **220** may only be disposed on a single side. Further details and embodiments relating to the shape of the connector **200** and the arrangement of the leads **220** are included below.

FIG. 6A is a perspective view of a feedthrough electrical connector **200**, according to another embodiment. The feedthrough electrical connector **200** may have a tapered

12

design, thus potentially making the insertion of the outwardly positioned portion **213** into a mating receptacle (not shown) easier. In another embodiment (not shown), sealing portion **212** may be tapered so as to reduce the effective footprint (cross-sectional area) of the connector **200**, thus reducing the size of the feedthrough aperture and reducing the likelihood of leakage between the interior cavity **110** and the exterior atmosphere **120** or rendering the sealing process more efficient/effective. In one embodiment, the cross-sectional area of the electrical connector **200**, at least at the sealing portion **212**, is less than about 200 square millimeters. In another embodiment, the cross-sectional area of the electrical connector **200** is less than about 100 square millimeters.

FIG. 6B is a side view of the feedthrough electrical connector **200** of FIG. 6A with corresponding mating receptacles **300**, according to one embodiment. The mating receptacles **300** have electrical contact pads **302** that, upon inserting the proper portion of the feedthrough electrical connector **200** into the receptacle, the leads **220**, **230** engage the electrical contact pads **302** and an electrical connection is made. The mating receptacles **300** may be electrically coupled to other components. Although not depicted, the mating receptacles **300** and/or the feedthrough electrical connector **200** may have a securing mechanism that fastens the connector in place. The securing mechanism may be a latch, a clamp, a tie, a fastener, a bolt, clasp, pin, clip, etc. In another embodiment, the connector may be held in place merely by the snug fit of the connector **200** within the mating receptacle(s) **300**.

As described above, the number, configuration, arrangement, and general dimensions of the leads **220**, **230** are not restricted to the embodiments depicted in the Figures. Additionally, it is contemplated that the connector may have shapes other than those depicted and described in the present disclosure. For example, the electrical connector may have a generally racetrack-shaped, ellipse-shaped, or oval-shaped outer periphery. In other words the outer perimeter of the electrical connector **200**, or at least the outer perimeter of one of the portions **211**, **212**, **213** of the connector **200**, may have various shapes. For example, the outer perimeter of the connector **200** may include two opposing sides extending substantially parallel to each other, with the sides being coupled together by semi-circular ends. In another embodiment, the outer perimeter (i.e., footprint) of the connector **200** may have a circular shape. In contrast to traditional feedthrough connectors, the connector **200** may be void of relatively sharp corners or edges.

FIG. 7 is a magnified perspective view of a feedthrough electrical connector **200**, according to one embodiment. The electrical connector **200** includes leads **220** disposed on peripheral surfaces of the electrically insulating base **210**. As depicted, multiple leads **220** may be spaced apart in multiple directions across the peripheral surfaces of the electrically insulating base **210**. For example, the not only can the leads **220** be spaced apart across the width of the connector **200**, the leads **220** may be spaced apart down the length of the connector **200**. The electrically insulating base **210** may include multiple layers **210a**, **210b**, **210c**, **210d**, **210e**, **210f** formed together. In between adjacent layers, electrical traces **240** can be electrically connected to the leads **220** and extend the length of the connector **200** to connect with corresponding leads/contact points **230** on the opposite end (e.g., between the inwardly positioned portion **211** to the outwardly positioned portion **213**). The electrical traces **240** may be constructed from any electrically conductive material that is suited for use in an electrical device. For example,

the electrical traces **240** may be constructed of metals such as copper, aluminum, gold, zinc, nickel, brass, bronze, iron, platinum, etc. In another embodiment, the electrical traces **240** may be constructed of other conductive materials, such as graphite and conductive polymers. The number and configuration of the traces **240** and the layers **210a**, **210b**, **210c**, **210d**, **210e**, **210f** is not limited to the depicted embodiment. Depending on the specifics of a given application, many layers **210a**, **210b**, **210c**, **210d**, **210e**, **210f** may be incorporated to properly route the traces **240**.

In the above description, certain terms may be used such as “up,” “down,” “upper,” “lower,” “horizontal,” “vertical,” “left,” “right,” and the like. These terms are used, where applicable, to provide some clarity of description when dealing with relative relationships. But, these terms are not intended to imply absolute relationships, positions, and/or orientations. For example, with respect to an object, an “upper” surface can become a “lower” surface simply by turning the object over. Nevertheless, it is still the same object. Further, the terms “including,” “comprising,” “having,” and variations thereof mean “including but not limited to” unless expressly specified otherwise. An enumerated listing of items does not imply that any or all of the items are mutually exclusive and/or mutually inclusive, unless expressly specified otherwise. The terms “a,” “an,” and “the” also refer to “one or more” unless expressly specified otherwise. Further, the term “plurality” can be defined as “at least two.”

Additionally, instances in this specification where one element is “coupled” to another element can include direct and indirect coupling. Direct coupling can be defined as one element coupled to and in some contact with another element. Indirect coupling can be defined as coupling between two elements not in direct contact with each other, but having one or more additional elements between the coupled elements. Further, as used herein, securing one element to another element can include direct securing and indirect securing. Additionally, as used herein, “adjacent” does not necessarily denote contact. For example, one element can be adjacent another element without being in contact with that element.

As used herein, the phrase “at least one of”, when used with a list of items, means different combinations of one or more of the listed items may be used and only one of the items in the list may be needed. The item may be a particular object, thing, or category. In other words, “at least one of” means any combination of items or number of items may be used from the list, but not all of the items in the list may be required. For example, “at least one of item A, item B, and item C” may mean item A; item A and item B; item B; item A, item B, and item C; or item B and item C. In some cases, “at least one of item A, item B, and item C” may mean, for example, without limitation, two of item A, one of item B, and ten of item C; four of item B and seven of item C; or some other suitable combination.

Unless otherwise indicated, the terms “first,” “second,” etc. are used herein merely as labels, and are not intended to impose ordinal, positional, or hierarchical requirements on the items to which these terms refer. Moreover, reference to, e.g., a “second” item does not require or preclude the existence of, e.g., a “first” or lower-numbered item, and/or, e.g., a “third” or higher-numbered item.

The present subject matter may be embodied in other specific forms without departing from its spirit or essential characteristics. The described embodiments are to be considered in all respects only as illustrative and not restrictive. The scope of the invention is, therefore, indicated by the

appended claims rather than by the foregoing description. All changes which come within the meaning and range of equivalency of the claims are to be embraced within their scope.

What is claimed is:

1. An apparatus, comprising:

a housing defining an interior cavity, the housing comprising a spring aperture;

a spring coupled to the housing over the spring aperture to at least partially cover the spring aperture, wherein the spring comprises a deflection portion and a feedthrough aperture; and

an electrical connector comprising an insulated base directly coupled to the spring and extending through the feedthrough aperture and the spring aperture, the insulated base comprising a sealing portion to form a seal with the spring, an outwardly positioned portion partially exterior to the housing, and an inwardly positioned portion partially within the interior cavity of the housing.

2. The apparatus of claim 1, wherein the electrical connector is indirectly coupled to the housing via the spring.

3. The apparatus of claim 1, further comprising at least one support bracket coupled to the housing, wherein the at least one support bracket is in supporting engagement with the electrical connector.

4. The apparatus of claim 3, wherein the electrical connector is indirectly coupled to the housing via the spring and the at least one support bracket.

5. The apparatus of claim 1, wherein the deflection portion of the spring absorbs thermal expansion of one or more of the electrical connector and the housing.

6. The apparatus of claim 1, wherein the deflection portion extends entirely around the feedthrough aperture.

7. The apparatus of claim 1, wherein the deflection portion comprises a rectangular footprint.

8. The apparatus of claim 1, wherein the deflection portion comprises an oval footprint.

9. The apparatus of claim 1, wherein the spring comprises multiple, spaced-apart deflection portions.

10. The apparatus of claim 1, wherein the spring is directly coupled to an external surface of the housing adjacent the spring aperture.

11. The apparatus of claim 1, wherein the spring is directly coupled to a sidewall of the spring aperture of the housing.

12. The apparatus of claim 1, wherein a first seal between the spring and the housing and a second seal between the spring and the electrical connector maintain the interior cavity as a hermetically sealed environment.

13. The apparatus of claim 12, wherein the interior cavity contains a helium-enriched environment.

14. The apparatus of claim 12, wherein at least one of the first seal and the second seal comprises one or more of solder, adhesive, and epoxy, the epoxy having a low helium permeability.

15. A hard disk drive, comprising:

a hermetically sealed housing defining and substantially isolating an interior cavity containing a helium enriched environment from an exterior atmosphere, the housing comprising a spring aperture having a first cross-sectional area;

a spring coupled to the hermetically sealed housing over the spring aperture, wherein the spring comprises a deflection portion and a feedthrough aperture, the feedthrough aperture having a second cross-sectional area smaller than the first cross-sectional area; and

an electrical connector comprising an insulated base directly coupled to the spring and extending through the feedthrough aperture and the spring aperture, the insulated base comprising a sealing portion to form a seal with the spring, an outwardly position portion 5 partially exterior to the housing, and an inwardly positioned portion partially within the interior cavity of the housing the electrical connector comprising a plurality of electrical traces extending from a location external to the hermetically sealed housing to a location within the 10 interior cavity of the hermetically sealed housing.

* * * * *