



US009687354B2

(12) **United States Patent**
Bellas et al.

(10) **Patent No.:** **US 9,687,354 B2**
(45) **Date of Patent:** **Jun. 27, 2017**

(54) **POSTERIOR INTERVERTEBRAL DISC
INSERTER AND EXPANSION TECHNIQUES**

2002/30579 (2013.01); A61F 2002/30617
(2013.01); A61F 2002/4415 (2013.01); A61F
2002/4627 (2013.01); A61F 2220/0025
(2013.01); A61F 2220/0091 (2013.01); A61F
2230/0006 (2013.01); A61F 2230/006
(2013.01); A61F 2230/0058 (2013.01); A61F
2250/0097 (2013.01)

(71) Applicant: **DePuy Synthes Products, Inc.**,
Raynham, MA (US)

(72) Inventors: **Jonathan Bellas**, East Taunton, MA
(US); **Seungkyu Daniel Kwak**,
Needham, MA (US); **Michael J.
O’Neil**, West Barnstable, MA (US);
John Riley Hawkins, Cumberland, RI
(US)

(58) **Field of Classification Search**
CPC A61F 2/4611; A61F 2/44; A61F 2/4425;
A61F 2/443
USPC 623/17.11–17.16; 606/99, 105
See application file for complete search history.

(73) Assignee: **DePuy Synthes Products, Inc.**,
Raynham, MA (US)

(56) **References Cited**

(*) Notice: Subject to any disclaimer, the term of this
patent is extended or adjusted under 35
U.S.C. 154(b) by 0 days.

U.S. PATENT DOCUMENTS

1,636,636 A 7/1927 Humble
1,677,337 A 7/1928 Grove
2,304,703 A 12/1942 O’Leary
(Continued)

(21) Appl. No.: **14/922,360**

(22) Filed: **Oct. 26, 2015**

FOREIGN PATENT DOCUMENTS

(65) **Prior Publication Data**
US 2016/0045325 A1 Feb. 18, 2016

CN 201244104 5/2009
DE 19710392 7/1999
(Continued)

Related U.S. Application Data

(63) Continuation of application No. 12/055,779, filed on
Mar. 26, 2008, now abandoned.

(51) **Int. Cl.**
A61F 2/44 (2006.01)
A61F 2/46 (2006.01)
A61F 2/30 (2006.01)

(52) **U.S. Cl.**
CPC *A61F 2/442* (2013.01); *A61F 2/4611*
(2013.01); *A61F 2/4425* (2013.01); *A61F*
2002/3052 (2013.01); *A61F 2002/30116*
(2013.01); *A61F 2002/30179* (2013.01); *A61F*
2002/30181 (2013.01); *A61F 2002/30405*
(2013.01); *A61F 2002/30471* (2013.01); *A61F*

OTHER PUBLICATIONS

Schmiedberg; “Isolation and characterization of metallic wear
debris from a dynamic intervertebral disc prosthesis”; J. Biomed.
Mater. Res.; vol. 28 Issue 11; 1994; p. 1277-1288; abstract.

Primary Examiner — Eduardo C Robert
Assistant Examiner — Michelle C Eckman
(74) *Attorney, Agent, or Firm* — Baker & Hostetler LLP

(57) **ABSTRACT**
Insertion and expansion devices for use in inserting motion
discs, and associated methods of use.

39 Claims, 7 Drawing Sheets

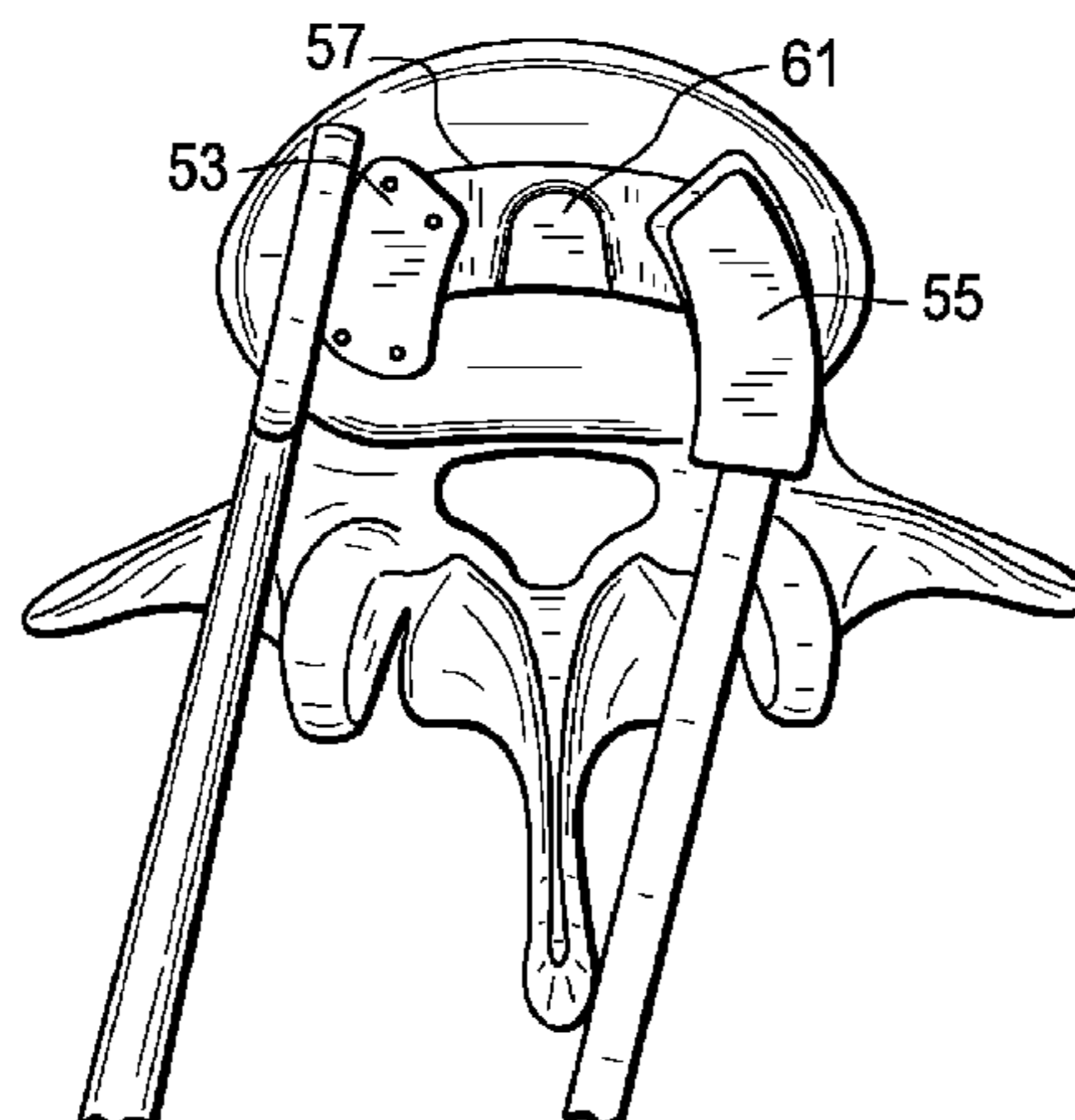

(56)

References Cited

U.S. PATENT DOCUMENTS

4,105,034 A	8/1978	Shalaby	6,193,757 B1	2/2001	Foley et al.	
4,130,639 A	12/1978	Shalaby	6,200,306 B1	3/2001	Klostermeyer	
4,140,678 A	2/1979	Shalaby	6,206,922 B1	3/2001	Zdeblick	
4,141,087 A	2/1979	Shalaby	6,231,610 B1	5/2001	Geisler	
4,205,399 A	6/1980	Shalaby	6,235,059 B1	5/2001	Benezech	
4,208,511 A	6/1980	Shalaby	6,306,170 B2	10/2001	Ray	
4,743,256 A	5/1988	Brantigan	6,330,845 B1	12/2001	Meulink	
4,904,261 A	2/1990	Dove	6,336,928 B1	1/2002	Guerin	
4,955,908 A	9/1990	Frey	6,342,055 B1	1/2002	Eisermann	
5,041,113 A	8/1991	Biedermann	6,342,074 B1	1/2002	Simpson	
5,123,926 A	6/1992	Pisharodi	6,364,880 B1	4/2002	Michelson	
5,147,361 A	9/1992	Ojima et al.	6,368,351 B1	4/2002	Glenn et al.	
5,209,751 A	5/1993	Farris et al.	6,375,462 B2	4/2002	Holweg et al.	
5,306,308 A	4/1994	Gross et al.	6,387,130 B1 *	5/2002	Stone	A61F 2/4455 623/17.16
5,352,231 A	10/1994	Brumfield	6,395,031 B1	5/2002	Foley et al.	
5,391,170 A	2/1995	McGuire	6,406,478 B1	6/2002	Kuo	
5,395,372 A	3/1995	Holt	6,409,766 B1	6/2002	Brett	
5,397,364 A	3/1995	Kozak	6,413,278 B1	7/2002	Marchosky	
5,443,514 A	8/1995	Steffee	6,423,063 B1	7/2002	Bonutti	
5,443,515 A	8/1995	Cohen	6,428,575 B2	8/2002	Koo	
5,464,407 A	11/1995	McGuire	6,432,106 B1	8/2002	Fraser	
5,464,929 A	11/1995	Bezwada	6,447,546 B1	9/2002	Bramlet	
5,499,986 A	3/1996	Dimarco	6,454,769 B2	9/2002	Wagner et al.	
5,529,580 A	6/1996	Kusunoki	6,461,359 B1	10/2002	Tribus	
5,534,031 A	7/1996	Matsuzaki	6,471,724 B2	10/2002	Zdeblick	
5,578,034 A	11/1996	Estes	6,488,710 B2	12/2002	Besselink	
5,591,166 A	1/1997	Bernhardt et al.	6,508,818 B2	1/2003	Steiner et al.	
5,595,751 A	1/1997	Bezwada	6,558,387 B2	5/2003	Errico	
5,597,579 A	1/1997	Bezwada	6,558,423 B1	5/2003	Michelson	
5,601,553 A	2/1997	Trebing et al.	6,562,073 B2	5/2003	Foley	
5,607,687 A	3/1997	Bezwada	6,565,570 B2	5/2003	Sterett	
5,609,636 A	3/1997	Kohrs et al.	6,572,619 B2	6/2003	Santilli	
5,618,552 A	4/1997	Bezwada	6,579,290 B1	6/2003	Hardcastle	
5,620,458 A	4/1997	Green et al.	6,602,257 B1	8/2003	Thramann	
5,620,698 A	4/1997	Bezwada	6,629,998 B1	10/2003	Lin	
5,645,598 A	7/1997	Brosnahan, III	6,682,563 B2	1/2004	Scharf	
5,645,850 A	7/1997	Bezwada	6,695,846 B2	2/2004	Richelsoph	
5,648,088 A	7/1997	Bezwada	6,730,125 B1	5/2004	Lin	
5,662,655 A	9/1997	Laboureau	6,730,127 B2	5/2004	Michelson	
5,676,666 A	10/1997	Oxland et al.	6,733,531 B1	5/2004	Trieu	
5,698,213 A	12/1997	Jamiolkowski	6,736,850 B2	5/2004	Davis	
5,700,583 A	12/1997	Jamiolkowski	6,743,257 B2	6/2004	Castro	
5,713,899 A	2/1998	Marnay	6,745,255 B2	6/2004	Yen et al.	
5,716,415 A	2/1998	Steffee	6,761,738 B1	7/2004	Boyd	
5,755,796 A	5/1998	Ibo et al.	6,770,096 B2	8/2004	Bolger	
5,776,196 A	7/1998	Matsuzaki	6,773,437 B2	8/2004	Ogilvie	
5,779,707 A	7/1998	Bertholet	6,776,781 B1	8/2004	Uwaydah	
5,785,713 A	7/1998	Jobe	6,805,714 B2	10/2004	Sutcliffe	
5,788,698 A	8/1998	Savornin	6,808,537 B2	10/2004	Michelson	
5,797,912 A	8/1998	Runciman	6,824,564 B2	11/2004	Crozet	
5,797,918 A	8/1998	McGuire	6,824,565 B2	11/2004	Muhanna et al.	
5,800,435 A	9/1998	Errico et al.	6,833,006 B2	12/2004	Foley et al.	
5,800,440 A	9/1998	Stead	6,835,208 B2	12/2004	Marchosky	
5,859,150 A	1/1999	Jamiolkowski	6,837,905 B1	1/2005	Lieberman	
5,888,223 A	3/1999	Bray, Jr.	6,849,093 B2	2/2005	Michelson	
5,904,689 A	5/1999	Jonjic	6,890,335 B2	5/2005	Grabowski	
5,913,860 A	6/1999	Scholl	6,890,355 B2	5/2005	Michelson	
6,039,761 A	3/2000	Li et al.	6,945,973 B2	9/2005	Bray	
6,049,026 A	4/2000	Muschler	6,972,019 B2	12/2005	Michelson	
6,056,749 A	5/2000	Kuslich	6,974,479 B2	12/2005	Trieu	
6,066,175 A	5/2000	Henderson	6,974,480 B2	12/2005	Messerli et al.	
6,086,593 A	7/2000	Bonutti	6,984,234 B2	1/2006	Bray	
6,093,205 A	7/2000	McLeod	7,001,385 B2	2/2006	Bonutti	
6,099,531 A	8/2000	Bonutti	7,033,394 B2	4/2006	Michelson	
6,106,557 A	8/2000	Robioneck	7,041,135 B2	5/2006	Michelson	
6,117,174 A	9/2000	Nolan	7,044,971 B2	5/2006	Suddaby	
6,120,503 A	9/2000	Michelson	7,056,341 B2	6/2006	Crozet	
6,126,689 A	10/2000	Brett	7,063,491 B2	6/2006	French	
6,139,550 A	10/2000	Michelson	7,070,598 B2	7/2006	Lim et al.	
6,156,037 A	12/2000	LeHuec	7,077,864 B2	7/2006	Byrd, III	
6,159,211 A	12/2000	Boriani	7,087,055 B2	8/2006	Lim et al.	
6,159,244 A	12/2000	Suddaby	7,112,222 B2	9/2006	Fraser	
6,174,311 B1	1/2001	Branch et al.	7,112,223 B2	9/2006	Davis	
6,179,875 B1	1/2001	Von Strempel	7,135,024 B2	11/2006	Cook	
6,190,414 B1	2/2001	Young et al.	7,135,043 B2	11/2006	Nakahara	
			7,163,561 B2	1/2007	Michelson	
			7,172,627 B2	2/2007	Fiere	
			7,226,482 B2	6/2007	Messerli	

(56)

References Cited

U.S. PATENT DOCUMENTS

7,232,463 B2	6/2007	Falahee	8,496,708 B2	7/2013	Blain
7,232,464 B2	6/2007	Mathieu	8,500,783 B2	8/2013	Baynham
7,238,203 B2	7/2007	Bagga	8,551,175 B1	10/2013	Wensel
7,238,206 B2	7/2007	Lange	8,562,651 B2	10/2013	Metcalf et al.
7,255,698 B2	8/2007	Michelson	8,597,330 B2	12/2013	Siegal
7,276,081 B1	10/2007	Coates	8,613,772 B2	12/2013	Bray et al.
7,288,094 B2	10/2007	Lindemann	8,617,245 B2	12/2013	Brett
7,288,095 B2	10/2007	Baynham	8,628,578 B2	1/2014	Miller et al.
7,288,114 B2	10/2007	Lange	8,641,765 B2	2/2014	Muhanna
7,306,605 B2	12/2007	Ross	8,672,977 B2	3/2014	Siegal et al.
7,309,358 B2	12/2007	Berry	8,690,928 B1	4/2014	Walkenhorst et al.
7,311,734 B2	12/2007	Van Hoeck	8,690,948 B2	4/2014	Armstrong et al.
7,316,714 B2	1/2008	Gordon	8,758,439 B2	6/2014	Linares
7,318,839 B2	1/2008	Malberg et al.	8,821,555 B2	9/2014	Bae
7,323,011 B2	1/2008	Shepard	8,900,235 B2	12/2014	Siegal
7,326,248 B2	2/2008	Michelson	8,906,098 B2	12/2014	Siegal
7,338,525 B2	3/2008	Ferree	8,932,359 B2	1/2015	Brett
7,341,587 B2	3/2008	Molz	8,956,416 B2	2/2015	McCarthy
7,341,590 B2	3/2008	Ferree	9,005,293 B2	4/2015	Moskowitz et al.
7,354,452 B2	4/2008	Foley	9,005,295 B2	4/2015	Kueenzi et al.
7,361,193 B2	4/2008	Frey	9,138,330 B2	9/2015	Hansell et al.
7,435,262 B2	10/2008	Michelson	9,192,419 B2	11/2015	McDonough et al.
7,438,715 B2	10/2008	Doubler	9,248,028 B2	2/2016	Gamache
7,442,209 B2	10/2008	Michelson	9,278,009 B2	3/2016	Bray et al.
7,452,370 B2	11/2008	Anderson	9,289,311 B1	3/2016	Whipple
7,491,237 B2	2/2009	Randall	9,402,738 B2	8/2016	Niemic
7,527,641 B2	5/2009	Suh	2001/0031968 A1	10/2001	Dorchak et al.
7,594,931 B2	9/2009	Louis et al.	2002/0029044 A1	3/2002	Monassevitch
7,594,932 B2	9/2009	Aferzon	2002/0029082 A1	3/2002	Muhanna
7,601,171 B2	10/2009	Ainsworth et al.	2002/0095155 A1	7/2002	Michelson
7,601,173 B2	10/2009	Messerli	2002/0099376 A1	7/2002	Michelson
7,608,062 B2	10/2009	Sweeney	2002/0138146 A1	9/2002	Jackson
7,618,456 B2	11/2009	Mathieu	2002/0151976 A1	10/2002	Foley et al.
7,628,816 B2	12/2009	Magerl	2002/0156475 A1	10/2002	Lerch et al.
7,641,665 B2	1/2010	Zubok	2003/0004576 A1	1/2003	Thalgott
7,655,042 B2	2/2010	Foley et al.	2003/0045940 A1	3/2003	Eberlein et al.
7,658,766 B2	2/2010	Melkent	2003/0050645 A1	3/2003	Parker
7,662,182 B2	2/2010	Zubok	2003/0083748 A1	5/2003	Lee et al.
7,674,279 B2	3/2010	Johnson	2003/0100949 A1	5/2003	Michelson
7,704,255 B2	4/2010	Michelson	2003/0125739 A1	7/2003	Bagga
7,726,002 B2	6/2010	Shimp et al.	2003/0153975 A1	8/2003	Byrd
7,794,502 B2	9/2010	Michelson	2003/0158555 A1	8/2003	Sanders
7,815,643 B2	10/2010	Johnson et al.	2003/0187506 A1	10/2003	Ross
7,815,681 B2	10/2010	Ferguson	2003/0195632 A1	10/2003	Foley
7,846,206 B2	12/2010	Leonard et al.	2003/0225409 A1	12/2003	Freid et al.
7,846,210 B2	12/2010	Perez-Cruet et al.	2004/0024464 A1	2/2004	Errico
7,862,616 B2	1/2011	Lechmann et al.	2004/0034430 A1	2/2004	Falahee
7,871,441 B2	1/2011	Eckman	2004/0092929 A1	5/2004	Zindrick
7,875,062 B2	1/2011	Lindemann	2004/0106996 A1	6/2004	Liu et al.
7,875,076 B2	1/2011	Mathieu	2004/0111089 A1	6/2004	Stevens et al.
7,883,531 B2	2/2011	de Coninck et al.	2004/0127902 A1	7/2004	Suzuki
7,887,591 B2	2/2011	Aebi et al.	2004/0127990 A1	7/2004	Bartish
7,887,595 B1	2/2011	Pimenta	2004/0138662 A1	7/2004	Landry et al.
7,909,877 B2	3/2011	Krueger et al.	2004/0153072 A1	8/2004	Bonutti
7,993,403 B2	8/2011	Foley et al.	2004/0167625 A1	8/2004	Beyar et al.
8,002,808 B2	8/2011	Morrison et al.	2004/0199253 A1	10/2004	Link
8,007,523 B2	8/2011	Wagner	2004/0199254 A1	10/2004	Louis
8,187,329 B2	5/2012	Theofilos	2004/0210219 A1	10/2004	Bray
8,206,423 B2	6/2012	Siegal	2004/0249377 A1	12/2004	Kaes
8,216,312 B2	7/2012	Gray	2004/0260286 A1	12/2004	Ferree
8,236,029 B2	8/2012	Siegal	2005/0021144 A1	1/2005	Malberg et al.
8,241,328 B2	8/2012	Siegal	2005/0033433 A1	2/2005	Michelson
8,323,342 B2	12/2012	Schwab	2005/0038513 A1	2/2005	Michelson
8,336,559 B2	12/2012	Kallabat et al.	2005/0043800 A1	2/2005	Paul et al.
8,343,219 B2	1/2013	Allain	2005/0065608 A1	3/2005	Michelson
8,349,015 B2	1/2013	Bae et al.	2005/0071006 A1	3/2005	Kirschman
8,357,200 B2	1/2013	Adl	2005/0071008 A1	3/2005	Kirschman
8,454,694 B2	6/2013	Armstrong et al.	2005/0085913 A1	4/2005	Fraser
8,460,385 B1	6/2013	Wensel	2005/0096657 A1	5/2005	Autericque et al.
8,460,387 B2	6/2013	Theofilos	2005/0101960 A1	5/2005	Fiere et al.
8,465,524 B2	6/2013	Siegal	2005/0113920 A1	5/2005	Foley et al.
8,470,044 B2	6/2013	Bertholet et al.	2005/0143749 A1	6/2005	Zalenski
8,480,747 B2	7/2013	Melkent et al.	2005/0143827 A1	6/2005	Globerman et al.
8,486,109 B2	7/2013	Siegal	2005/0149192 A1	7/2005	Zucherman
8,491,658 B1	7/2013	Etminan	2005/0149193 A1	7/2005	Zucherman
			2005/0154391 A1	7/2005	Doherty et al.
			2005/0159813 A1	7/2005	Molz
			2005/0177240 A1	8/2005	Blain
			2005/0177245 A1	8/2005	Leatherbury et al.

(56)		References Cited		2008/0133014 A1*	6/2008	Gately A61F 2/4425 623/17.16
		U.S. PATENT DOCUMENTS		2008/0161925 A1	7/2008	Brittan
				2008/0167666 A1	7/2008	Fiere
				2008/0177307 A1	7/2008	Moskowitz
				2008/0183293 A1	7/2008	Parry
				2008/0183294 A1	7/2008	Adl
				2008/0221690 A1	9/2008	Chaput
				2008/0221694 A1	9/2008	Warnick et al.
				2008/0243136 A1	10/2008	Prager
				2008/0249569 A1	10/2008	Waugh
				2008/0249575 A1	10/2008	Waugh
				2008/0249625 A1	10/2008	Waugh
				2008/0255620 A1	10/2008	Strauss
				2008/0269806 A1	10/2008	Zhang
				2008/0281425 A1	11/2008	Thalgott
				2008/0294262 A1	11/2008	Levieux
				2008/0300601 A1	12/2008	Fabian et al.
				2008/0300634 A1	12/2008	Gray
				2008/0306596 A1	12/2008	Jones
				2008/0306598 A1	12/2008	Hansen
				2008/0312698 A1	12/2008	Bergeron
				2008/0312742 A1	12/2008	Abernathie
				2009/0012529 A1	1/2009	Blain et al.
				2009/0030421 A1	1/2009	Hawkins
				2009/0030519 A1	1/2009	Falahee
				2009/0030520 A1	1/2009	Biedermann
				2009/0062921 A1	3/2009	Michelson
				2009/0088849 A1	4/2009	Armstrong
				2009/0099554 A1	4/2009	Forster
				2009/0099610 A1	4/2009	Johnson et al.
				2009/0105771 A1	4/2009	Lei
				2009/0105774 A1	4/2009	Jones
				2009/0105830 A1	4/2009	Jones
				2009/0105831 A1	4/2009	Jones
				2009/0105832 A1	4/2009	Allain et al.
				2009/0125028 A1	5/2009	Teisen et al.
				2009/0131988 A1	5/2009	Bush
				2009/0132054 A1	5/2009	Zeegers
				2009/0143859 A1	6/2009	McClellan
				2009/0164020 A1	6/2009	Janowski
				2009/0182428 A1	7/2009	McClellan et al.
				2009/0182430 A1	7/2009	Tyber
				2009/0192549 A1	7/2009	Sanders
				2009/0192613 A1	7/2009	Wing
				2009/0192615 A1	7/2009	Tyber
				2009/0192616 A1	7/2009	Zielinski
				2009/0198245 A1	8/2009	Phan
				2009/0198287 A1	8/2009	Chiu
				2009/0198339 A1	8/2009	Kleiner et al.
				2009/0210062 A1	8/2009	Thalgott
				2009/0210064 A1	8/2009	Lechmann
				2009/0234364 A1	9/2009	Crook
				2009/0265007 A1	10/2009	Colleran
				2009/0287251 A1	11/2009	Bae
				2009/0306779 A1	12/2009	Ahn
				2009/0326543 A1	12/2009	Fabian
				2009/0326580 A1	12/2009	Anderson et al.
				2009/0326589 A1	12/2009	Lemoine et al.
				2010/0004747 A1	1/2010	Lin
				2010/0016901 A1	1/2010	Robinson
				2010/0016973 A1*	1/2010	de Villiers A61F 2/4611 623/17.16
				2010/0023128 A1	1/2010	Malberg
				2010/0030334 A1	2/2010	Molz, IV
				2010/0036496 A1	2/2010	Yu
				2010/0042159 A1	2/2010	Butler
				2010/0057206 A1	3/2010	Duffield
				2010/0070037 A1	3/2010	Parry et al.
				2010/0087925 A1	4/2010	Kostuik
				2010/0106249 A1	4/2010	Tyber
				2010/0145457 A1	6/2010	Felt
				2010/0145459 A1	6/2010	McDonough
				2010/0145460 A1	6/2010	McDonough
				2010/0185289 A1	7/2010	Kirwan
				2010/0185292 A1	7/2010	Hochschuler et al.
				2010/0204739 A1	8/2010	Bae et al.
				2010/0217325 A1	8/2010	Hochschuler et al.
				2010/0217393 A1	8/2010	Theofilos
		2005/0182416 A1	8/2005	Lim et al.		
		2005/0209696 A1	9/2005	Lin et al.		
		2005/0251260 A1	11/2005	Gerber et al.		
		2005/0261768 A1	11/2005	Trieu		
		2005/0277938 A1	12/2005	Parsons		
		2005/0278036 A1	12/2005	Leonard		
		2006/0025860 A1	2/2006	Li		
		2006/0030851 A1	2/2006	Bray		
		2006/0058801 A1	3/2006	Schlienger et al.		
		2006/0079961 A1	4/2006	Michelson		
		2006/0085071 A1	4/2006	Lechmann		
		2006/0129424 A1	6/2006	Chan		
		2006/0142765 A9	6/2006	Dixon		
		2006/0142858 A1	6/2006	Colleran et al.		
		2006/0142863 A1	6/2006	Fraser		
		2006/0178745 A1	8/2006	Bartish et al.		
		2006/0211952 A1	9/2006	Kennedy		
		2006/0229609 A1	10/2006	Wang		
		2006/0229729 A1	10/2006	Gordon et al.		
		2006/0235403 A1	10/2006	Blain		
		2006/0235409 A1	10/2006	Blain		
		2006/0235518 A1	10/2006	Blain		
		2006/0235535 A1	10/2006	Ferree		
		2006/0241597 A1	10/2006	Mitchell et al.		
		2006/0241761 A1	10/2006	Gately		
		2006/0247650 A1	11/2006	Yerby et al.		
		2006/0259147 A1	11/2006	Krishna et al.		
		2006/0293753 A1	12/2006	Thramann		
		2007/0049941 A1	3/2007	Thramann		
		2007/0055252 A1	3/2007	Blain		
		2007/0067035 A1*	3/2007	Falahee A61F 2/4455 623/17.11		
		2007/0073398 A1*	3/2007	Fabian A61F 2/442 623/17.11		
		2007/0106384 A1	5/2007	Bray		
		2007/0106388 A1	5/2007	Michelson		
		2007/0129804 A1	6/2007	Bentley		
		2007/0162138 A1	7/2007	Heinz		
		2007/0198016 A1	8/2007	Zang et al.		
		2007/0213737 A1	9/2007	Schemmerhorn et al.		
		2007/0219635 A1	9/2007	Mathieu		
		2007/0233118 A1	10/2007	McLain		
		2007/0233253 A1	10/2007	Bray		
		2007/0233261 A1	10/2007	Lopez et al.		
		2007/0233263 A1	10/2007	Melkent		
		2007/0250167 A1	10/2007	Bray		
		2007/0255416 A1	11/2007	Melkent		
		2007/0265631 A1	11/2007	Fox		
		2007/0270957 A1	11/2007	Heinz		
		2007/0270965 A1	11/2007	Ferguson		
		2007/0276490 A1	11/2007	Mateyka		
		2007/0282449 A1*	12/2007	de Villiers A61F 2/4425 623/17.15		
		2007/0293948 A1	12/2007	Bagga		
		2007/0299521 A1*	12/2007	Glenn A61F 2/4425 623/17.11		
		2008/0015694 A1	1/2008	Tribus		
		2008/0027550 A1	1/2008	Link		
		2008/0033440 A1	2/2008	Moskowitz		
		2008/0051890 A1	2/2008	Waugh et al.		
		2008/0051897 A1	2/2008	Lopez et al.		
		2008/0065219 A1	3/2008	Dye		
		2008/0077247 A1	3/2008	Murillo		
		2008/0082173 A1	4/2008	Delurio		
		2008/0097436 A1	4/2008	Culbert		
		2008/0103597 A1*	5/2008	Lechmann A61F 2/4425 623/17.16		
		2008/0103598 A1	5/2008	Trudeau et al.		
		2008/0109005 A1	5/2008	Trudeau et al.		
		2008/0125865 A1	5/2008	Abdelgany		
		2008/0132949 A1	6/2008	Aferzon		
		2008/0132958 A1	6/2008	Pech		
		2008/0133012 A1	6/2008	McGuckin		

(56)

References Cited

U.S. PATENT DOCUMENTS

2010/0249935 A1 9/2010 Slivka
 2010/0249937 A1 9/2010 Blain et al.
 2010/0286777 A1 11/2010 Errico
 2010/0286781 A1 11/2010 Bullard
 2010/0292696 A1 11/2010 Chantelot
 2010/0292737 A1 11/2010 Suh
 2010/0305704 A1 12/2010 Messerli
 2010/0312345 A1 12/2010 Duffield
 2011/0009908 A1 1/2011 Ferguson
 2011/0009966 A1 1/2011 Michelson
 2011/0015675 A1 1/2011 Howard
 2011/0015745 A1 1/2011 Bucci
 2011/0082550 A1 4/2011 Yeh
 2011/0082555 A1 4/2011 Martz
 2011/0098747 A1 4/2011 Donner et al.
 2011/0106159 A1 5/2011 Nazeck
 2011/0144703 A1 6/2011 Krause et al.
 2011/0184415 A1 7/2011 Anderson et al.
 2011/0190892 A1 8/2011 Kirschman
 2011/0202136 A1 8/2011 Brittan et al.
 2011/0208311 A1 8/2011 Janowski
 2011/0213421 A1 9/2011 Binder et al.
 2011/0230971 A1 9/2011 Donner et al.
 2011/0251689 A1 10/2011 Seifert
 2011/0319998 A1 12/2011 O'Neil
 2012/0041559 A1 2/2012 Melkent et al.
 2012/0078371 A1 3/2012 Gamache
 2012/0078372 A1 3/2012 Gamache
 2012/0078373 A1 3/2012 Gamache
 2012/0083889 A1 4/2012 Purcell et al.
 2012/0150301 A1 6/2012 Gamache
 2012/0150303 A1 6/2012 Linares
 2012/0158143 A1 6/2012 Shapiro
 2012/0197401 A1 8/2012 Duncan
 2012/0203230 A1 8/2012 Adams
 2012/0209331 A1 8/2012 Michelson
 2012/0226319 A1 9/2012 Armstrong et al.
 2012/0253406 A1 10/2012 Bae
 2013/0060337 A1 3/2013 Petersheim et al.
 2013/0073044 A1 3/2013 Gamache
 2013/0166027 A1 6/2013 Bellas
 2013/0238095 A1 9/2013 Pavento et al.
 2013/0268080 A1 10/2013 Melkent et al.
 2013/0325071 A1 12/2013 Niemiec et al.
 2013/0345813 A1 12/2013 Frank et al.
 2014/0039623 A1 2/2014 Iott et al.
 2014/0067069 A1 3/2014 Lopez
 2014/0107786 A1 4/2014 Geisler et al.
 2014/0114415 A1 4/2014 Tyber
 2014/0135930 A1 5/2014 Georges
 2014/0142705 A1 5/2014 Duffield et al.
 2014/0156009 A1 6/2014 Armstrong et al.

2014/0172103 A1 6/2014 O'Neil et al.
 2014/0364917 A1 12/2014 Sandstrom
 2015/0297356 A1 10/2015 Gamache et al.
 2015/0313721 A1 11/2015 Gamache et al.
 2015/0374511 A1 12/2015 Pavento et al.
 2016/0128846 A1 5/2016 Voellmicke
 2016/0213487 A1 7/2016 Wilson et al.

FOREIGN PATENT DOCUMENTS

EP 1459711 B1 7/2007
 EP 1683490 7/2008
 EP 1506753 B1 9/2009
 EP 1774926 6/2010
 EP 1847240 11/2011
 FR 2894130 6/2007
 GB 2220729 1/1990
 GB 2457673 8/2009
 WO WO 98/04217 2/1998
 WO WO 98/34568 A1 8/1998
 WO WO 99/52473 10/1999
 WO WO 99/38463 11/1999
 WO WO 01/08864 2/2001
 WO WO 02/13732 5/2002
 WO WO 03/003951 A1 1/2003
 WO WO 03/005938 1/2003
 WO WO 03/005939 5/2003
 WO WO 03/070128 8/2003
 WO WO 03/090650 11/2003
 WO WO 2004/069106 8/2004
 WO WO 2005/020861 3/2005
 WO WO 2006/084057 8/2006
 WO WO 2006/058281 A3 10/2006
 WO WO 2007/003785 1/2007
 WO WO 2007/118856 10/2007
 WO WO 2007/098288 3/2008
 WO WO 2008/149223 12/2008
 WO WO 2009/025841 2/2009
 WO WO 2009/064644 5/2009
 WO WO 2009/091775 9/2009
 WO WO 2009/136009 11/2009
 WO WO 2010/028045 3/2010
 WO WO 2010/033786 3/2010
 WO WO 2010/054208 5/2010
 WO WO 2010/092893 8/2010
 WO WO 2010/099239 9/2010
 WO WO 2010/121028 10/2010
 WO WO 2011/008864 1/2011
 WO WO 2011/080535 7/2011
 WO WO 2012/056119 5/2012
 WO WO 2013/018062 2/2013
 WO WO 2013/096192 6/2013
 WO WO 2013/191979 12/2013

* cited by examiner

FIG. 1

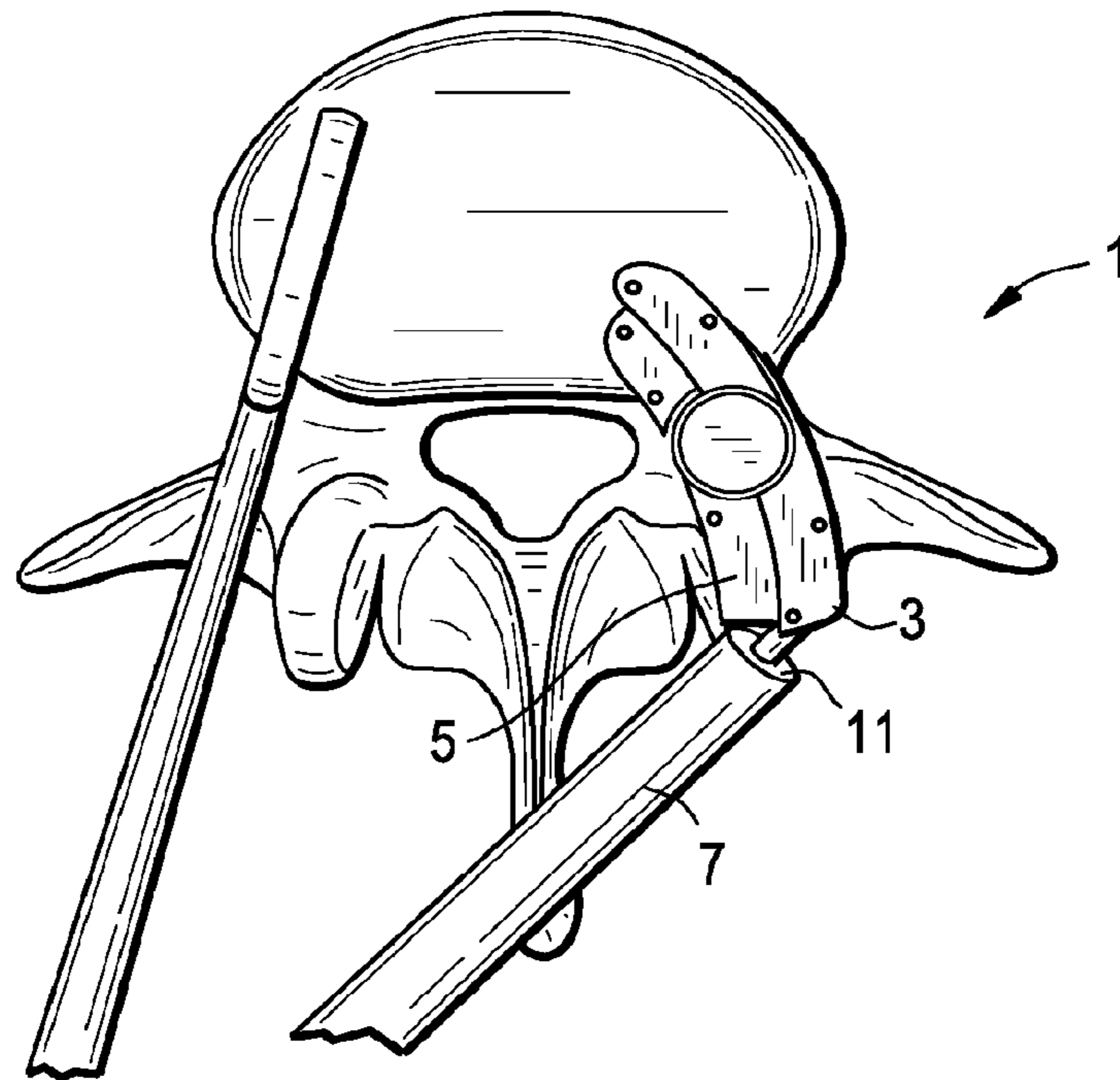

FIG. 2

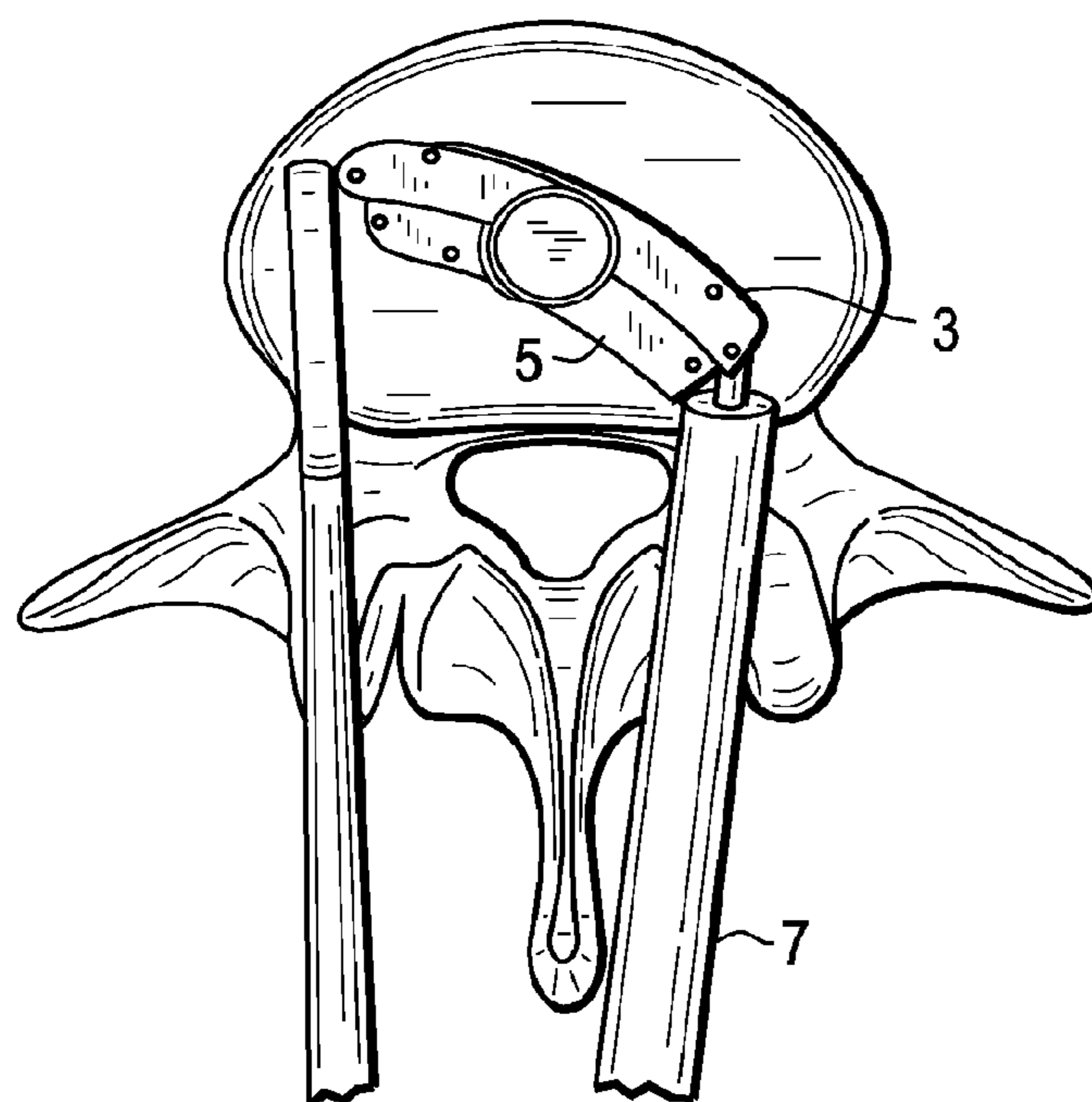

FIG. 3

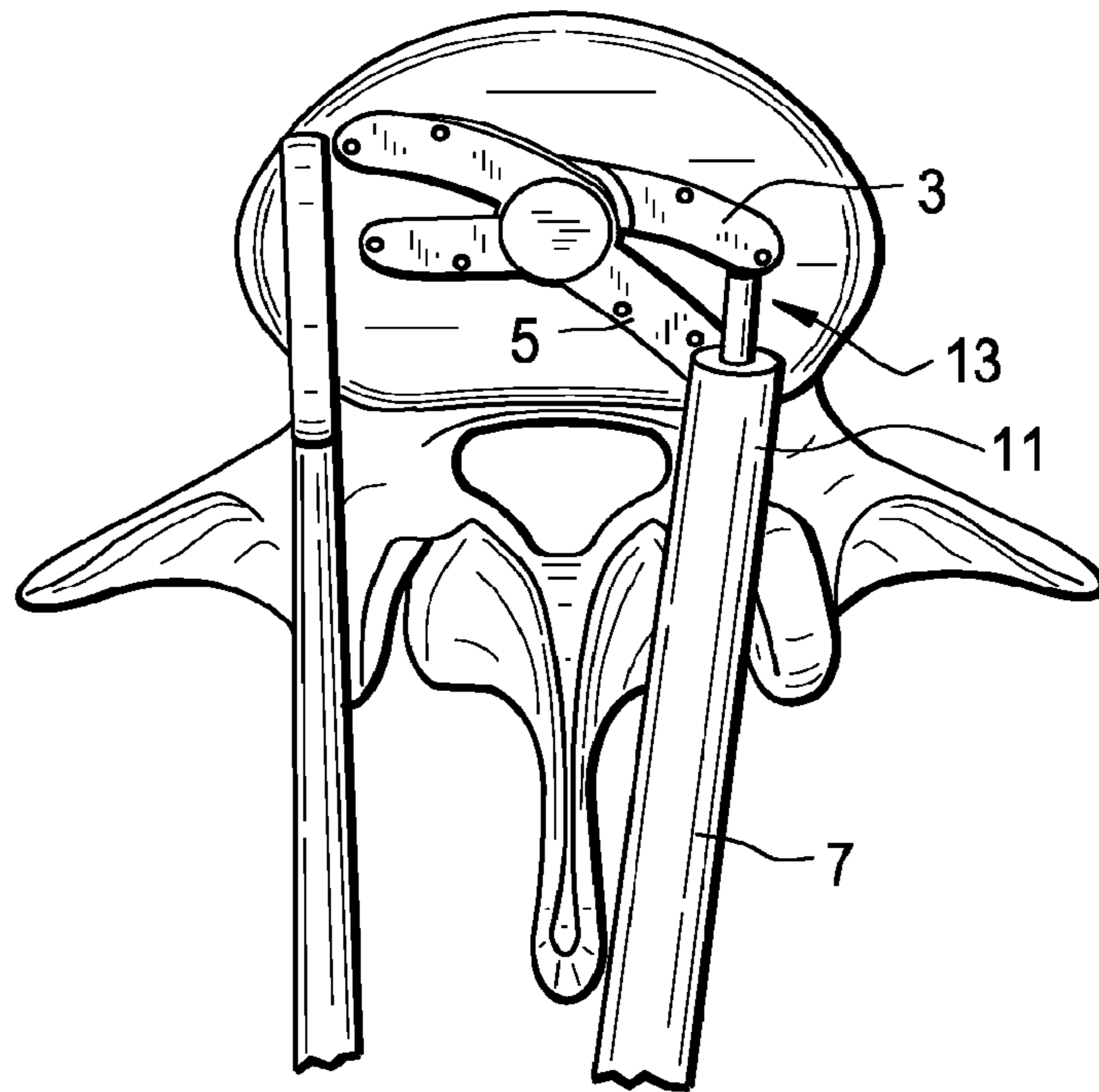

FIG. 4

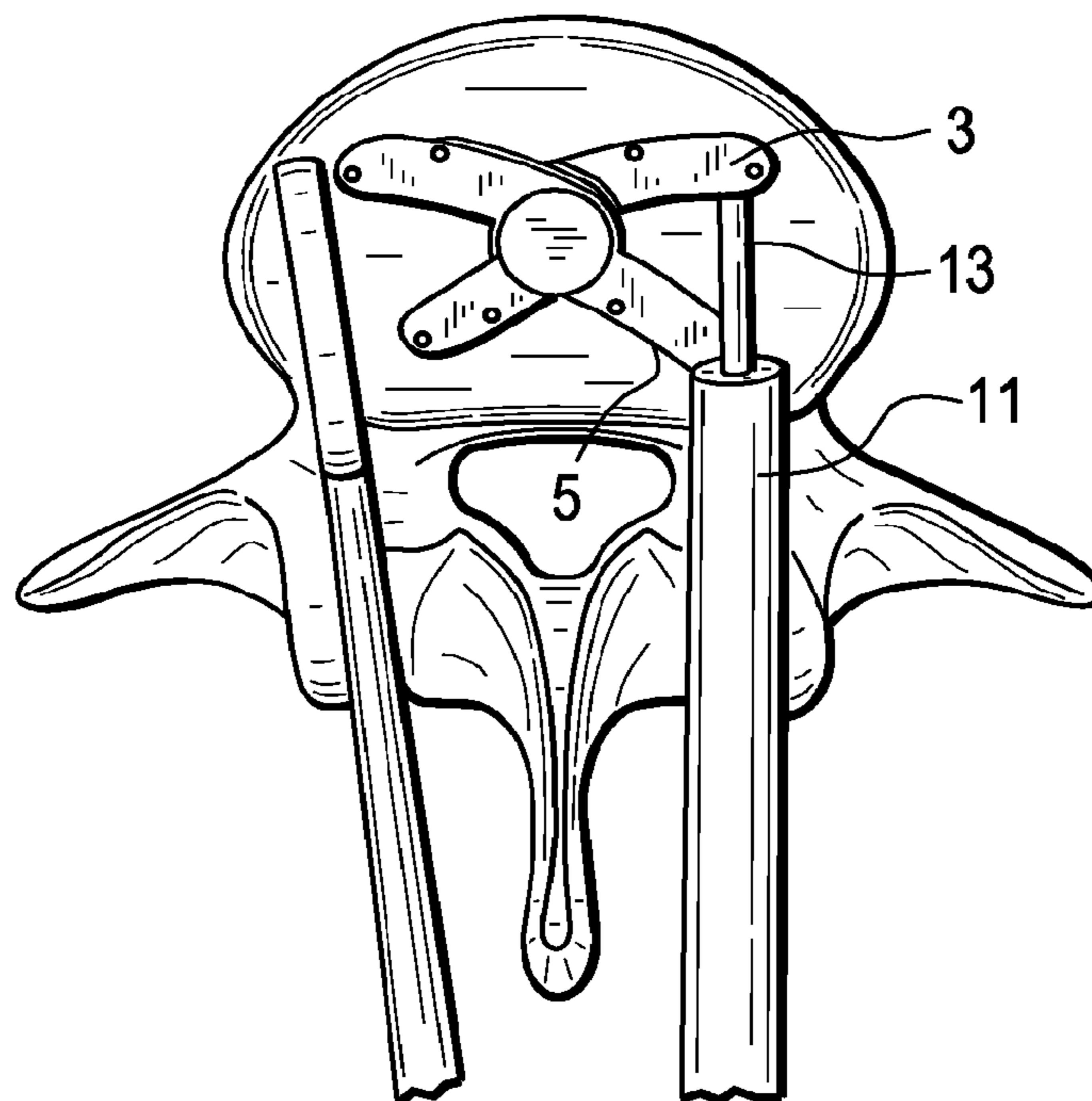

FIG. 5

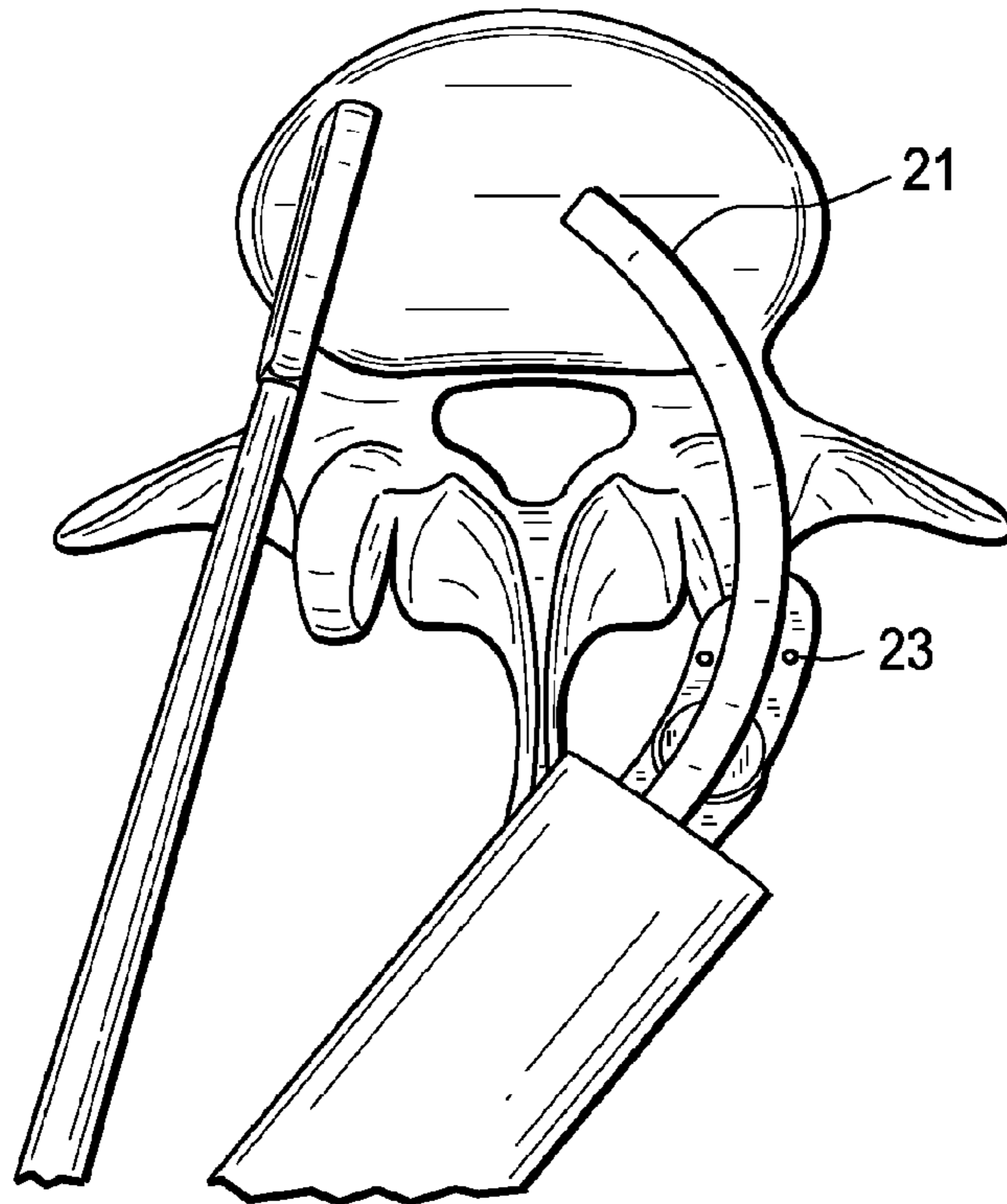

FIG. 6

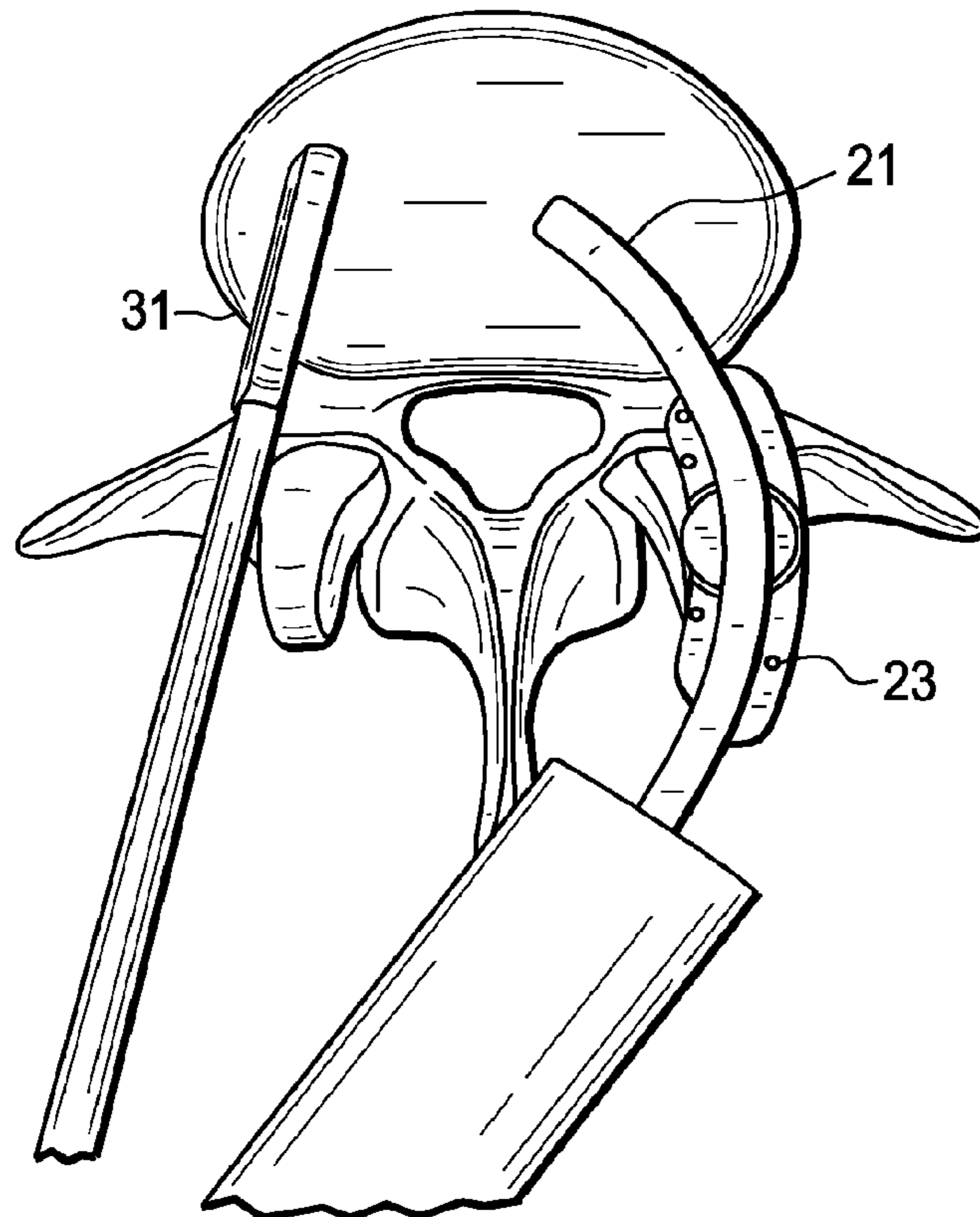

FIG. 7

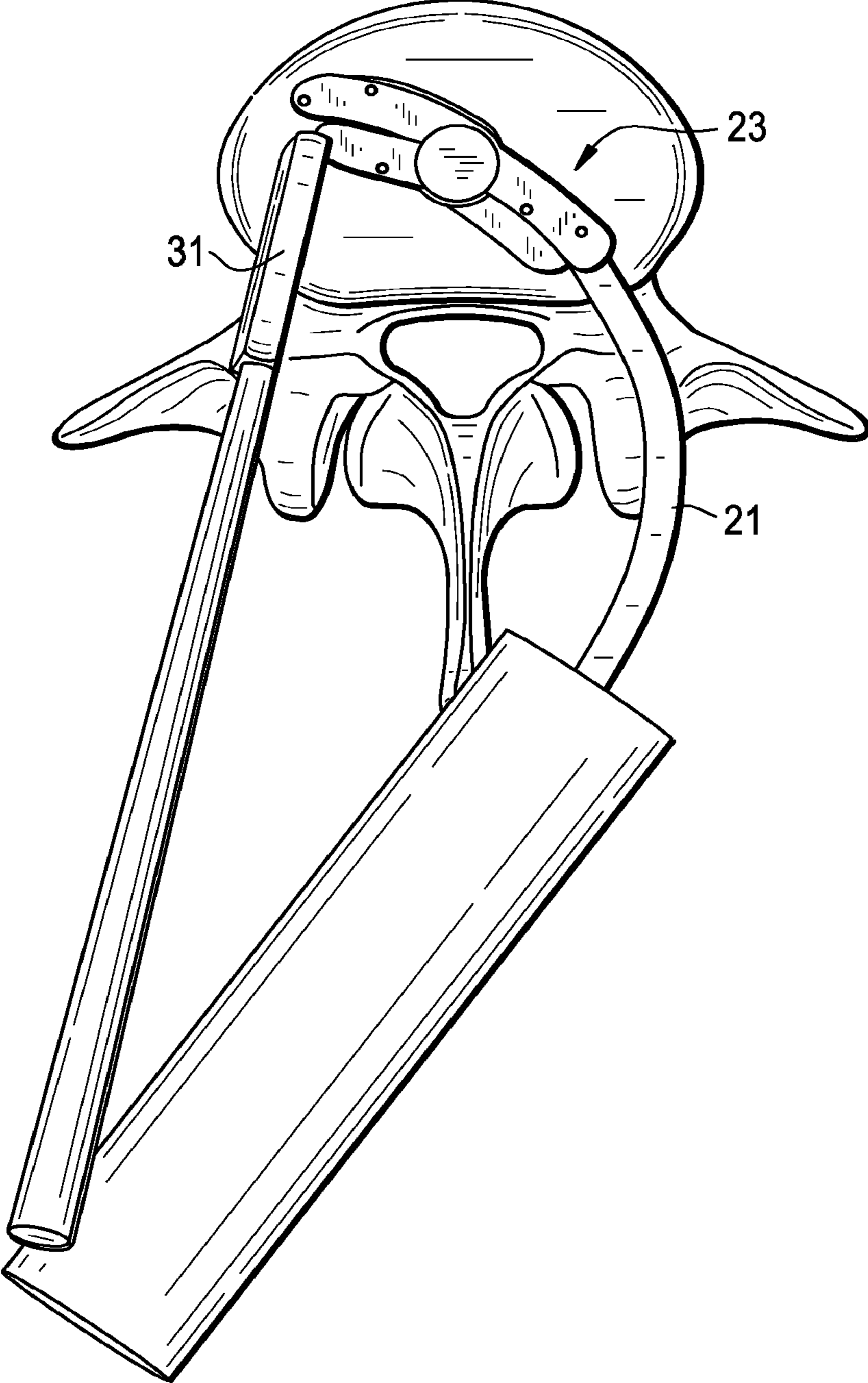

FIG. 8

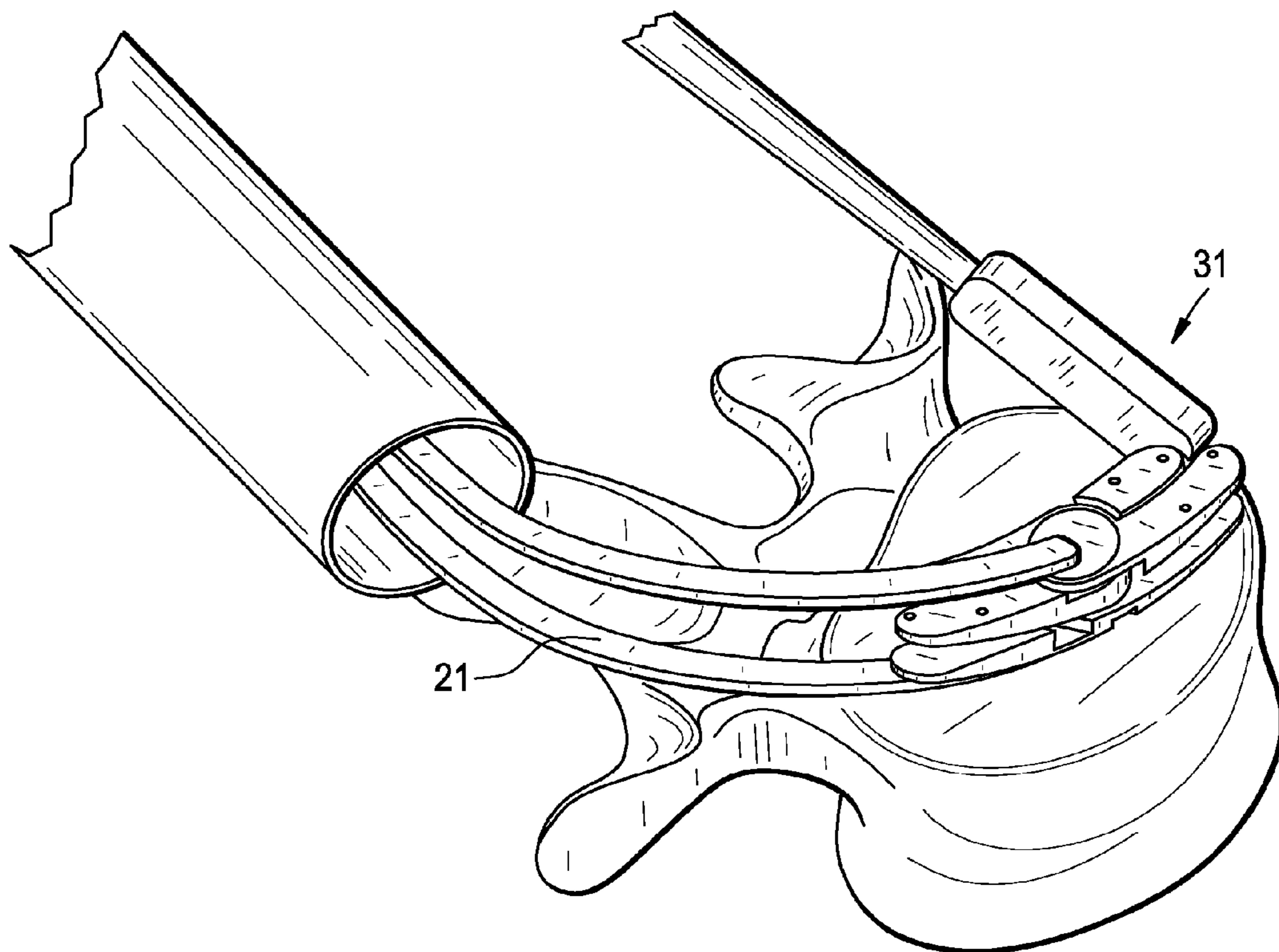

FIG. 9

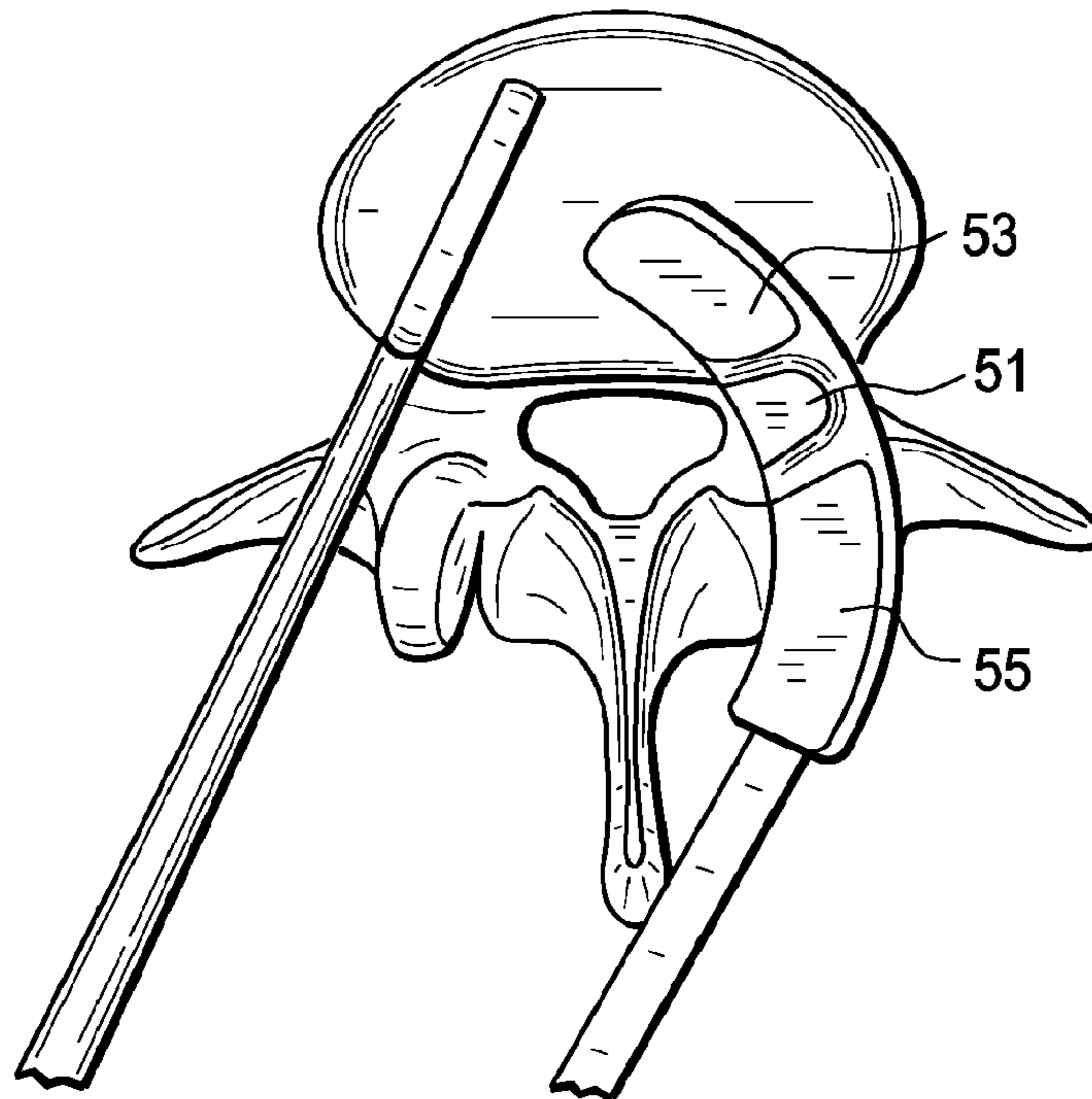

FIG. 10

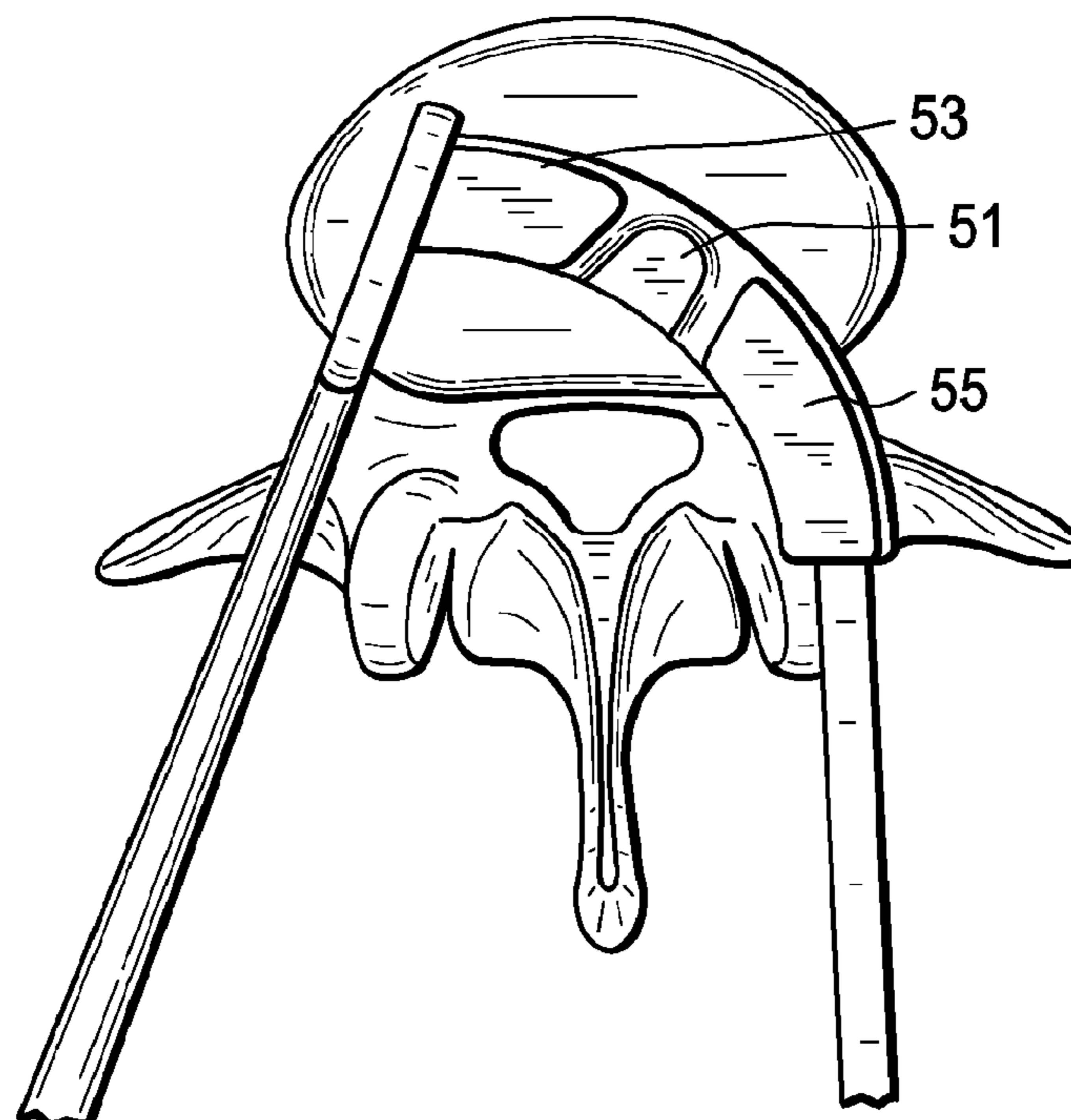

FIG. 11

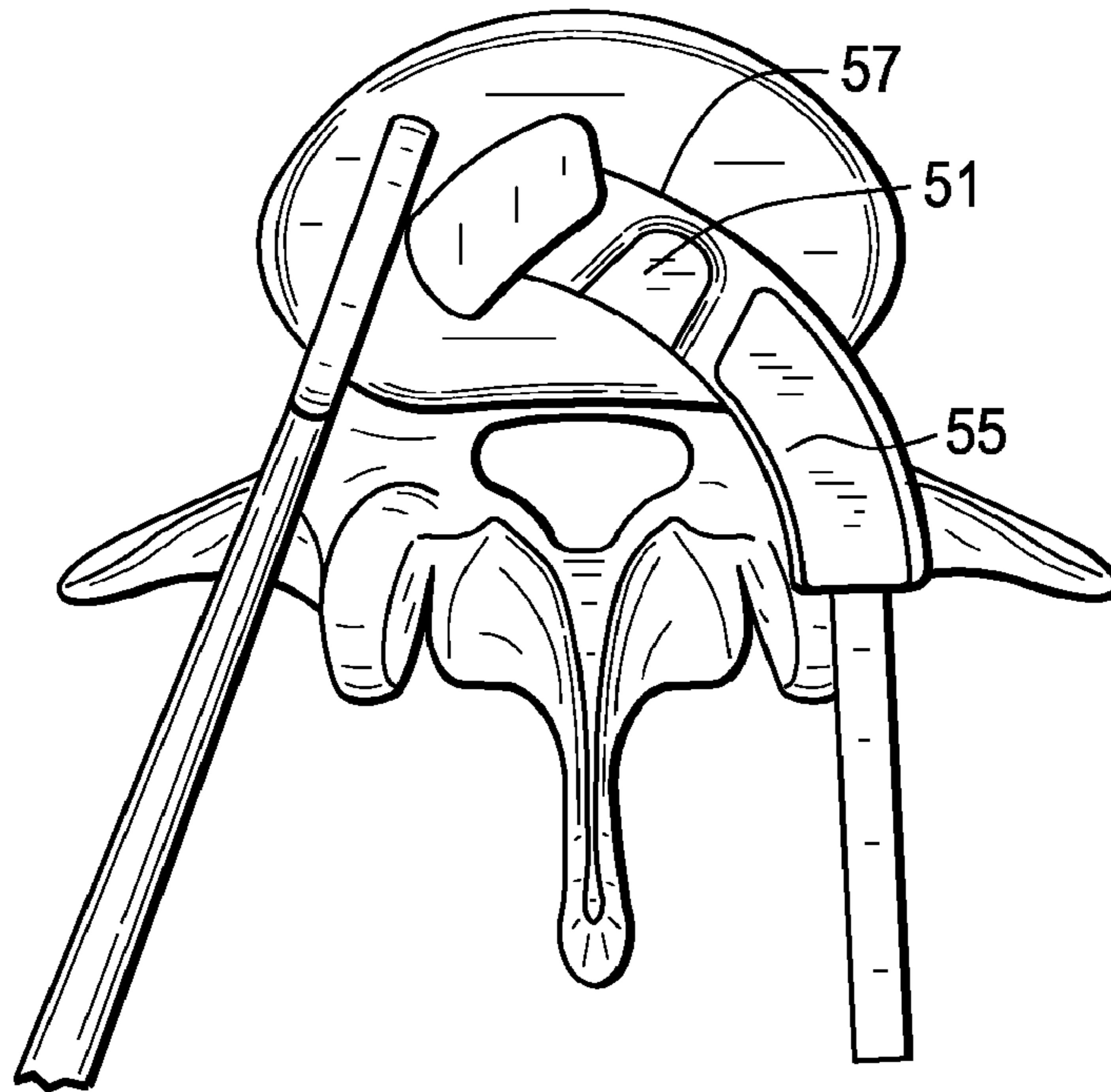
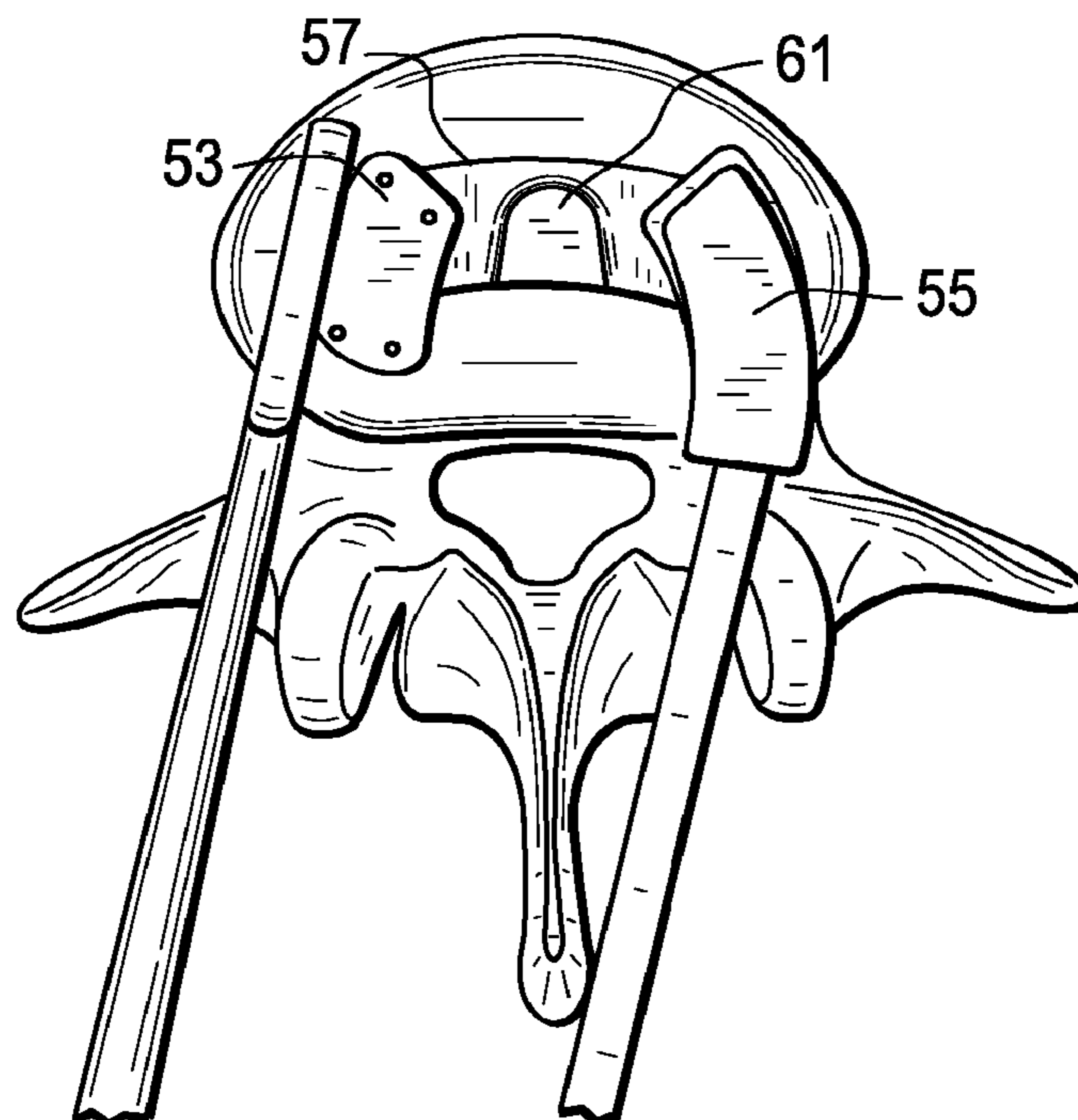

FIG. 12



1

**POSTERIOR INTERVERTEBRAL DISC
INSERTER AND EXPANSION TECHNIQUES**

CROSS-REFERENCE TO RELATED
APPLICATIONS

This is a continuation application of U.S. patent application Ser. No. 12/055,779 filed Mar. 26, 2008, the disclosure of which is hereby incorporated by reference as if set forth in its entirety herein.

BACKGROUND OF THE INVENTION

The leading cause of lower back pain arises from rupture or degeneration of lumbar intervertebral discs. Pain in the lower extremities is caused by the compression of spinal nerve roots by a bulging disc, while lower back pain is caused by collapse of the disc and by the adverse effects of articulation weight through a damaged, unstable vertebral joint. One proposed method of managing these problems is to remove the problematic disc and replace it with a prosthetic disc that allows for the natural motion between the adjacent vertebrae (“a motion disc”).

There are many types of motion disc inserters disclosed in the prior art. These devices generally hold the inferior and superior endplates of the motion disc for “line of site” insertion. Positive stops and measurement devices are also employed on these inserters to determine the appropriate depth of implant placement.

PCT Published Patent Application WO 2006-058281 (“Glenn”) discloses a spinal implant to be inserted between two vertebra to support and stabilize adjacent vertebra and allow for physiological motion. The invention includes an implantable device to support the vertebrae, and a minimally invasive method for inserting and deploying the device within the intervertebral space.

SUMMARY OF THE INVENTION

The present invention relates to insertion and expansion devices for use in inserting intervertebral motion discs, and associated methods of use. They are grouped into two separate devices and techniques as follows:

In a first embodiment, the inserter has a longitudinal handle having a distal pair of holders for holding a proximal end of a pivoting motion disc, wherein one of the holders is axially deployable within the handle. The pair of holders secure the proximal legs of the implant for insertion into the disc space. This assembly utilizes an implant first methodology, wherein this assembly is inserted into the disc space in an orientation wherein the implant is on the leading end of the assembly. Once the motion disc is placed into the disc space, a secondary deployer associated with the handle is activated to axially move one of the holders, thereby moving one of the legs relative to the other leg and thereby changing the disc device footprint (e.g., pivoting one of the legs). Several expansion mechanisms can be used to expand the legs of the implant.

The approach used in conjunction with this first embodiment may include one or more annular locations. For example, in some embodiments, the approach is ipsilateral. In some embodiments, the approach is contralateral, or both. In some embodiments, the first embodiment of the present invention produces an X-shaped artificial intervertebral disc in its expanded condition. However, other expanded motion disc geometries, such as an H-shape artificial intervertebral disc in its expanded condition, are also contemplated.

2

Therefore, in accordance with the present invention, there is provided a method of inserting a curvilinear motion disc having a first and second legs connected by a pivot, each leg having an endportion, the method comprising the steps of:

- a) providing the motion disc in a collapsed position,
- b) providing a motion disc inserter comprising a handle having a longitudinal axis and a first end having first holder and a deployer, the deployer being axially moveable along the axis of the handle,
- c) attaching the first endportion of the motion disc to the first holder,
- d) contacting the second endportion of the motion disc to the deployer,
- e) arcuately inserting the motion disc into the disc space in the collapsed condition, and
- f) axially moving the deployer to move the second leg and to expand the motion disc into an open condition.

Therefore, in accordance with the present invention, there is provided an assembly for inserting a curvilinear motion disc into a disc space, the assembly comprising:

- a) a curvilinear motion disc having first and second pivoting legs, each leg having an endportion, wherein the first and second leg endportions are in a first collapsed position, and wherein the first and second leg endportions are in a second expanded position, and
- b) an inserter comprising a handle having a longitudinal axis and a first end having a first holder and a deployer, the deployer being axially moveable along the axis of the rod, wherein the first endportion of the motion disc is attached to the first holder, and wherein the second endportion of the motion disc is attached to the deployer.

In a second embodiment, the insertion instrument possesses an insertion track. The insertion track instrument is inserted into the disc space by itself and creates an annular shield for the motion disc implant (thereby protecting the disc). It also provides a guide or track for the subsequently-placed motion disc implant insertion and placement to follow during insertion. Lastly, the guide/track facilitates expansion of the motion disc footprint by holding the central axis pivot point.

Therefore, in accordance with the present invention, there is provided a method of inserting a curvilinear motion disc having first and second endportions, the method comprising the steps of:

- a) providing the motion disc in a collapsed position wherein the first and second endportions are close together,
- b) inserting into a disc space a distal portion of a motion disc inserter comprising a tubular proximal portion and a curved distal portion comprising upper and lower rails,
- c) advancing the motion disc in the collapsed condition through the motion disc inserter to insert the motion disc into the disc space and rotate the motion disc, and
- d) expanding the motion disc into an open condition in the disc space.

The methods of the present invention differ from those of the prior art because the present methods employ non-linear insertion techniques with instruments having deployment features that expand or change the footprint of an artificial intervertebral disc implant.

Some embodiments of this invention differs from prior art because it employs an expansion means to change location and footprint of the artificial disc, wherein the expansion means is independent of the insertion method.

This invention differs from the prior art because it does not use screw attachment to couple the inserter to the implant.

DESCRIPTION OF THE FIGURES

FIG. 1 discloses inserting a first motion disc/inserter assembly into the disc space, wherein the motion disc is in a collapsed condition.

FIG. 2 discloses advancing the motion disc of FIG. 1 further into the disc space to rotate the motion disc.

FIG. 3 discloses the initial actuation of the deployer to expand the motion disc to a partially expanded condition.

FIG. 4 discloses the complete actuation of the deployer to expand the motion disc to a final expanded condition.

FIG. 5 discloses advancing a motion disc up a linear proximal portion of a second motion inserter, wherein the motion disc is in a collapsed condition.

FIG. 6 discloses further advancing the motion disc of FIG. 5 through a curved intermediate portion of the inserter to rotate the motion disc.

FIG. 7 discloses further advancing the motion disc of FIG. 6 through a curved distal portion of the inserter to insert the motion disc into the disc space.

FIG. 8 discloses the final placement of the motion disc of the FIG. 7 in the disc space.

FIG. 9 discloses advancing an H-type motion disc up a linear proximal portion of a second motion inserter, wherein the motion disc is in a collapsed condition.

FIG. 10 discloses further advancing the motion disc of FIG. 9 through a curved distal portion of the inserter to rotate the motion disc and insert the motion disc into the disc space.

FIG. 11 discloses the initial actuation of the motion disc of FIG. 10 to expand a first leg of the motion disc.

FIG. 12 discloses the final actuation of the motion disc of FIG. 11 to expand a second leg of the motion disc.

DETAILED DESCRIPTION

Now referring to FIGS. 1-4, there is provided a method of inserting a motion disc having a first and second legs connected by a pivot, each leg having an endportion, the method comprising the steps of:

- a) providing the motion disc **1** in a collapsed position wherein the first **3** and second **5** leg endportions are close together,
- b) providing a motion disc inserter **7** comprising a handle having a longitudinal axis and a first end **11** having first **13** and second holders, the deployer being axially moveable along the axis of the handle,
- c) attaching the first endportion of the motion disc to the first holder,
- d) attaching the second endportion of the motion disc to the deployer,
- e) inserting the motion disc into the disc space in the collapsed condition, and
- f) axially moving the deployer to move the second leg and to expand the motion disc into an open condition.

In particular, and now referring to FIG. 1, the motion disc inserter secures the proximal portion of the motion disc implant for insertion into the disc space by grasping the top and bottom aspects of the proximal portion of the intradiscal device. Now referring to FIG. 2, the implant is inserted into its desired location in the disc space.

Now referring to FIG. 3, with the implant in its desired location, the deployment component of the inserter is acti-

vated to expand or adjust the implant shape for improved vertebra body contact and balanced load transfer. In particular, the expansion component of the inserter is activated to move the deployer axially and thereby pivot one of the legs of the implant shape. This produces expansion of the implant, improved vertebra body contact and a more balanced load transfer. Means for the axial movement of the deployer (and thereby the second leg) include: a) a rod that is slideably movable within a tube, b) a threaded rod that is threadably movable within a threaded tube, and c) a notched rod that is capable of ratcheted actuation.

FIG. 4 shows the motion disc in its expanded condition after it has been expanded by activation of the inserter.

The extent to which the deployer can be axially moved can be monitored via depth markings. In some embodiments, the depth markings are placed on the deployer. In some embodiments, the depth markings are placed on the insertion handle.

Although the inserter/deployer is shown in FIGS. 1-4 as being utilized in a posterior approach, it can be also used for other angles of approach, including lateral, anterior, and postero/lateral approaches.

The implant used in conjunction with the first embodiment can be of varying shape and configurations. Typically, it has at least one pivoting leg. In some embodiments, it has a pair of pivoting legs. An "X shaped" implant is shown in FIGS. 1-4. The X-shape can have multiple layers wherein inferior and superior layers are held or deployed individually or simultaneously. Other disc implant geometries can utilize the inserter holder/deployer of the first embodiment to insert an implant and change the footprint via disclosed the deployment means. An example of an alternate geometry is a "T"-, "Y"- or "H"-shaped implant.

In some embodiments, the handle portion of the present invention comprises a tube within which the deployer is contained. In some embodiments, the first holder is fixedly attached to the distal end portion of the tube. In other embodiments, the handle portion of the present invention comprises a solid rod, and the holders are attached to the outer surface of the rod.

The insertion track of the second embodiment of the present invention is curvilinear and has a blade, semi-tubular or tubular construction, thereby allowing negotiation of bony or soft tissues without damaging those tissues. This track provides a fixed route for insertion and rotation of the motion disc. In some embodiments, it has a substantially linear proximal portion and a curved distal portion. In some embodiments, the linear proximal portion is tubular. In some embodiments, the curved distal portion can also be tubular. However, in other embodiments, the curved distal portion can comprise upper and lower rails that mate with the upper and lower aspects of the motion disc. The insertion track also allows insertion of the motion disc via a trajectory more comparable to that of the inner wall of the annulus fibrosus, as compared to "line of site" linear insertion techniques. This compatible trajectory has the advantage of intruding upon less of the annulus fibrosus during device insertion. In use, the track is inserted into the disc space prior to insertion of the motion disc. Doing so creates an annular shield around the implant so that the implant can be safely inserted into the disc space. The curved feature of the insertion track also creates a guide for turning the device during device placement. It may also provide a method of changing the device footprint by virtue of a guiding pusher for expansion of shape.

5

Now referring to FIG. 5, there is provided an insertion track 21 of the present invention following its insertion into the disc space along the annular inner wall.

Now referring to FIG. 6, a motion disc implant 23 is shown advancing along this insertion track to enter the disc space. Now referring to FIG. 7, the implant is advanced along the track until its final desired central placement is obtained. The placement depth can be limited by a positive stop(s) along the insertion track (proximal tip stop (not shown)). The depth to which the implant is inserted into the disc space can be monitored via depth markings provided on the track and referencing off an adjacent vertebral body.

Several methods of advancing the device along the insertion track can be carried out in accordance with the present invention. These methods include using a pusher instrument that holds and pushes the proximal end of the implant to advance it distally along the track. Another possible method may use a puller comprising a cable wrapped around a pulley located at the distal tip of the track, wherein one free end of the cable is connected to the implant and the other free end extends out of the proximal tubular portion of the insertion track. In this case, providing a tensile or pull force on the cable moves the device distally along the track and into the disc space.

Various methods of deployment can be used to change the device footprint once the motion disc is placed within the disc space. In one embodiment, the method includes temporarily attaching interconnecting features that connect the insertion track to the implant, and withdrawing the insertion track from the disc space, thereby changing the footprint of the implant via the insertion track extraction forces. In a second embodiment, and now referring to FIG. 8, the method includes placing on the contra-lateral side of the disc space an instrument to create an advancement stop. Instrument 31 has a puller mechanism, activating the puller mechanism and pulling or pushing the motion disc into position. In alternate embodiments, the contralateral puller or pusher mechanism may be actuated to change the footprint configuration of the motion disc.

In some embodiments, the insertion track can be directly connected to the implant, which provides the advantage of controlled trajectory and final position. In other embodiments, the insertion track can be connected to a holder/spacer that is attached to the implant and the insertion track, which provides the advantage of determining the angle of approach and entry for the puller/pusher mechanism.

The implant used in conjunction with the second embodiment can be of varying shape and configurations. Typically, it has at least one pivoting leg. In some embodiments, it has a pair of pivoting legs. An X-shaped implant is shown in FIGS. 5-8. The X-shape can have multiple layers, wherein various inferior and superior layers are held and/or deployed individually or simultaneously. Other disc implant geometries can exploit the insertion track to insert an implant and change the footprint via disclosed deployment means. In some embodiments, the alternate implant geometry comprises a "T"-, "Y"- or "H"-shaped implant.

FIGS. 9-12 disclose the insertion and actuation of an H-type motion disc using the insertion track inserter of the present invention. This motion disc has a central body 51 having first 53 and second 55 endportions, wherein a first leg 57 is pivotally attached to the first endportion at a first pivot, and wherein a second leg 61 is pivotally attached to the second endportion at a second pivot. Upon expansion, each of the legs of this device pivots to an orientation perpendicular to the longitudinal axis of the central body, and the device takes on an "H" shape.

6

Now referring to FIG. 9, an H-type motion disc in a collapsed condition is advanced up a linear portion of the insertion track inserter. Now referring to FIG. 10, the H-type motion disc is further advanced through a curved portion of the insertion track inserter to rotate the motion disc and insert the motion disc into the disc space. Now referring to FIG. 11, initial actuation of the motion disc causes the pivoting of first leg of the motion disc and initial expansion of the motion disc. Now referring to FIG. 12, final actuation of the motion disc causes pivoting of the second leg of the motion disc and complete expansion of the motion disc.

Irrespective of the embodiment selected, if desired, an optional guide 101 (shown in FIG. 8) can be utilized during insertion and deployment to assist the surgeon in any one of disc space distraction, implant positioning, implant expansion, and/or verifying implant placement. This guide is typically placed on a contralateral side of the disc space. When the guide is used as a distractor, it typically has a transverse cross-section having a height and a width, wherein the width is greater than the height. The distractor is inserted into the disc space contralaterally so that its height dimension bears against the endplates. Prior to insertion of the motion disc, the distractor is rotated 90 degrees so that its width dimension now bears against the endplates, thereby increasing the height of the disc space.

Irrespective of the embodiment selected, in some embodiments, the inserter/deployer (as shown in FIGS. 1-4) or the insertion track (as shown in FIGS. 5-8) is used in a freehand manner. However, in other embodiments, the inserter/insertion track further comprises a docking means to dock onto or reference off nearby stable landmarks such as a vertebral body edge or a pedicle screw. Docking off of these locations provides for enhanced surgical stability and control.

Irrespective of the embodiment selected, intraoperative imaging techniques (including fluoroscopy) can be used to assist in or verify placement and deployment of the inserter and/or motion disc. Although the primary surgical approach shown is posterior or posterior/lateral, other approaches can be utilized.

Although the inserter/deployer and insertion track inserters are shown as being utilized posteriorly, they can be also used for other angles of approach including lateral, anterior, and posterior/lateral approaches.

We claim:

1. An intervertebral implant, comprising:

a) a central body having a longitudinal axis, a proximal endportion and a distal endportion, wherein the proximal endportion is offset from the distal endportion in a proximal direction,

b) a first leg pivotally attached to the proximal endportion, wherein the first leg has a first orientation substantially in-line with the longitudinal axis of the central body to provide a footprint of the implant,

wherein the first leg is pivotable from the first orientation to a second orientation that is substantially perpendicular to the longitudinal axis of the central body,

wherein the second orientation changes the footprint of the implant,

wherein the first leg defines an external concave surface and an external convex surface opposite the concave surface, and the concave surface faces a distal direction in the second orientation, the distal direction opposite the proximal direction, and an entirety of the convex surface translates as the first leg pivots from the first orientation to the second orientation, and

7

wherein when the first leg is in the second orientation, a proximal-most surface of the first leg is offset from the central body in the proximal direction.

2. The implant of claim 1, wherein the longitudinal axis of the central body is a curvilinear longitudinal axis.

3. The implant of claim 1, wherein the leg contacts an adjacent vertebral body.

4. The implant of claim 1, wherein the central body has an intermediate portion comprising a convex sidewall and a concave sidewall, wherein the convex sidewall is substantially parallel to the concave sidewall.

5. The implant of claim 1, wherein the first leg constitutes an upper surface of the implant.

6. A method of inserting the intervertebral implant of claim 1 into a disc space, comprising the steps of:

- a) attaching an inserter to the first leg of the intervertebral implant,
- b) after the attaching step, inserting the intervertebral implant into the disc space using the inserter,
- c) pivoting the first leg of the inserted implant.

7. The method of claim 6, wherein the inserting step includes initially inserting the implant so that the longitudinal axis of the central body has a substantially anterior-posterior orientation in the disc space.

8. The method of claim 7, wherein the inserting step comprises causing the longitudinal axis of the central body to have a substantially lateral orientation in the disc space.

9. The method of claim 8, wherein the first leg resides substantially anterior to the central body after step c).

10. The method of claim 9, wherein the leg contacts a vertebral body adjacent the disc space.

11. The method of claim 6, wherein the pivoting step comprises pivoting the first leg from the first orientation to the second orientation.

12. The method of claim 6, wherein the central body has an intermediate portion comprising a convex sidewall and a concave sidewall, wherein the convex sidewall is substantially parallel to and anterior to the concave sidewall.

13. The intervertebral implant of claim 1, wherein the central body defines a body width along a direction perpendicular to the longitudinal axis, the first leg defines a leg width along the direction perpendicular to the longitudinal axis, and in the first orientation the leg width is less than the body width.

14. A system comprising:
the intervertebral implant of claim 1; and
a pedicle screw.

15. An intervertebral implant, comprising:

- a) a central body having a longitudinal axis, a proximal endportion and a distal endportion, wherein the central body defines a central body width along a direction perpendicular to the longitudinal axis,
- b) a first leg pivotally attached to the proximal endportion, wherein the first leg has an external concave face and an external convex face opposite the concave face and spaced from the concave face along a central leg axis of the first leg,

wherein the first leg is pivotable between a first orientation whereby the central leg axis is angularly offset from the longitudinal axis, and a second orientation whereby the central leg axis extends substantially in a common direction as the longitudinal axis, and wherein the first leg defines a distance from the concave face to the convex face along the central leg axis, the distance less than the central body width.

16. The implant of claim 15, wherein the longitudinal axis of the central body is a curvilinear longitudinal axis.

8

17. The implant of claim 15, wherein the leg is configured to contact an adjacent vertebral body.

18. The implant of claim 15, wherein the central body has an intermediate portion comprising a convex sidewall and a concave sidewall, wherein the convex sidewall is substantially parallel to the concave sidewall.

19. The implant of claim 15, wherein the first leg constitutes an upper surface of the implant.

20. The intervertebral implant of claim 15, wherein the first leg defines a leg width along the direction perpendicular to the longitudinal axis, and the leg width is less than the body width when the first leg is in the first orientation.

21. A system comprising:
the intervertebral implant of claim 15; and
a pedicle screw.

22. The intervertebral implant of claim 15, wherein the central leg axis is substantially perpendicular to the longitudinal axis when the first leg is in the first orientation.

23. An assembly intervertebral implant comprising:

- a) a central body having endplates spaced from each other along a transverse direction, a longitudinal axis and proximal and distal endportions spaced from each other along the longitudinal axis, wherein the central body has a body width along a direction perpendicular to both the longitudinal axis and the transverse direction, and

- b) a first leg pivotally attached to the proximal endportion, the first leg having an external concave surface and an external convex surface opposite the concave surface, wherein the first leg has a first orientation substantially in-line with the longitudinal axis of the central body to provide a first implant footprint,

wherein the first leg is pivotable between the first orientation and a second orientation, whereby the first leg is angularly offset with respect to the longitudinal axis of the central body so as to produce a second implant footprint that is different than the first implant footprint, and

wherein when the leg is in the first orientation, 1) the first leg has a leg width along the direction perpendicular to both the longitudinal axis and the transverse direction, and 2) the leg width along an entirety of the first leg is less than the body width along an entirety of the central body.

24. The implant of claim 23, wherein the longitudinal axis of the central body is a curvilinear longitudinal axis.

25. The implant of claim 23, wherein the leg contacts an adjacent vertebral body.

26. The assembly of claim 23, wherein the distal endportion is offset from the proximal endportion in a distal direction, and the concave surface faces the distal direction in the second orientation.

27. The intervertebral implant of claim 23, wherein the first leg defines a first leg distance from the concave surface to the convex surface, and the first leg distance is less than the body width.

28. The intervertebral implant of claim 23, wherein the proximal endportion is spaced from the distal endportion in a proximal direction, and when the first leg is in the second orientation, a proximal-most surface of the first leg is offset from the central body in the proximal direction.

29. The intervertebral implant of claim 28, wherein the convex surface is spaced from the concave surface in the proximal direction when the first leg is in the second orientation.

9

30. A system comprising:
the intervertebral implant of claim **23**; and
a pedicle screw.

31. The system as recited in claim **30**, further comprising
an inserter configured to be attached to the first leg of the
intervertebral implant. 5

32. A system comprising:
the intervertebral implant of claim **23**; and
an inserter configured to be attached to the first leg of the
intervertebral implant. 10

33. An intervertebral implant for insertion between upper
and lower vertebral endplates, comprising:

a) a central body having opposed endplates spaced from
each other along a transverse direction and configured
to face the upper and lower vertebral endplates, respec- 15
tively, the central body elongate along a longitudinal
body axis, and the central body defining a proximal
endportion and a distal endportion, and

b) a first leg pivotally attached to the proximal endportion, 20
the first leg having an external concave surface and an
external convex surface opposite the concave surface
along a central leg axis of the first leg,

wherein the first leg has a first orientation whereby the
central leg axis is substantially in-line with the longi- 25
tudinal axis of the central body to provide a first
footprint of the implant, and

wherein the first leg is pivotable to define a second
orientation whereby the central leg axis is angularly
offset with respect to the longitudinal axis of the central
body to provide a second footprint of the implant that 30
is different than the first footprint, and

10

wherein the first leg is configured to define a position with
respect to the central body between the first orientation
and the second orientation such that a plane that
extends along both the longitudinal body axis and the
transverse direction passes through each of the concave
and convex surfaces.

34. The intervertebral implant of claim **33**, wherein the
convex surface is offset with respect to the concave surface
along the longitudinal body axis when the first leg is in the
second orientation. 10

35. The intervertebral implant of claim **33**, wherein the
central body defines a body width measured along a direc-
tion perpendicular to the longitudinal body axis, and the first
leg defines a leg width measured along the direction per-
pendicular to the longitudinal body-axis that is less than the 15
body width when the first leg is in the first orientation.

36. The intervertebral implant of claim **35**, wherein when
the first leg is in the second orientation, 1) the convex
surface is offset from the concave surface in a proximal
direction, and 2) a proximal-most surface of the first leg is
offset from the central body in the proximal direction. 20

37. The intervertebral implant as recited in claim **36**,
wherein the concave and convex surfaces are spaced from
each other a distance that is less than the body width.

38. A system comprising:
the intervertebral implant of claim **36**; and
a pedicle screw. 25

39. A system comprising:
the intervertebral implant of claim **33**; and
a pedicle screw. 30

* * * * *