



US009686572B2

(12) **United States Patent**
Klamer et al.

(10) **Patent No.:** **US 9,686,572 B2**
(45) **Date of Patent:** ***Jun. 20, 2017**

(54) **DIGITAL MEDIA DISTRIBUTION DEVICE**

(71) Applicant: **Warner Bros. Entertainment, Inc.**,
Burbank, CA (US)

(72) Inventors: **Paul Klamer**, La Canada, CA (US);
Ken Long, Los Angeles, CA (US);
Arjun Ramamurthy, Glendale, CA (US)

(73) Assignee: **WARNER BROS. ENTERTAINMENT INC.**, Burbank, CA (US)

(*) Notice: Subject to any disclaimer, the term of this patent is extended or adjusted under 35 U.S.C. 154(b) by 0 days.

This patent is subject to a terminal disclaimer.

(21) Appl. No.: **14/557,296**

(22) Filed: **Dec. 1, 2014**

(65) **Prior Publication Data**

US 2015/0089562 A1 Mar. 26, 2015

Related U.S. Application Data

(63) Continuation of application No. 14/144,462, filed on Dec. 30, 2013, now Pat. No. 8,904,466, which is a (Continued)

(51) **Int. Cl.**

H04N 7/173 (2011.01)
H04N 7/16 (2011.01)

(Continued)

(52) **U.S. Cl.**

CPC ... **H04N 21/234309** (2013.01); **H04N 19/157** (2014.11); **H04N 19/162** (2014.11); (Continued)

(58) **Field of Classification Search**

USPC 725/143-153; 348/722; 715/726-736
See application file for complete search history.

(56) **References Cited**

U.S. PATENT DOCUMENTS

4,081,747 A * 3/1978 Meyerle G08C 19/22
455/68
5,479,617 A * 12/1995 Nei H04N 7/108
341/143

(Continued)

OTHER PUBLICATIONS

European Office Action Dated Jul. 17, 2009, Re Application No. 04 780 741.7-1522. p. 1-3.

(Continued)

Primary Examiner — Mushfikh Alam

(74) *Attorney, Agent, or Firm* — Jonathan Jaech; Snell & Wilmer L.L.P.

(57) **ABSTRACT**

A digital media distribution device that includes an encoder, a decoder coupled to the encoder, and a transcoder coupled to the decoder. The encoder is configured to encode input data that is received by the digital media distribution device into a first data format. The decoder is configured to decode output data to be output by the digital media distribution device. The transcoder is configured to convert the encoded input data from the first data format into a second data format. The digital media distribution device is configured to be coupled to a computer network.

23 Claims, 1 Drawing Sheet

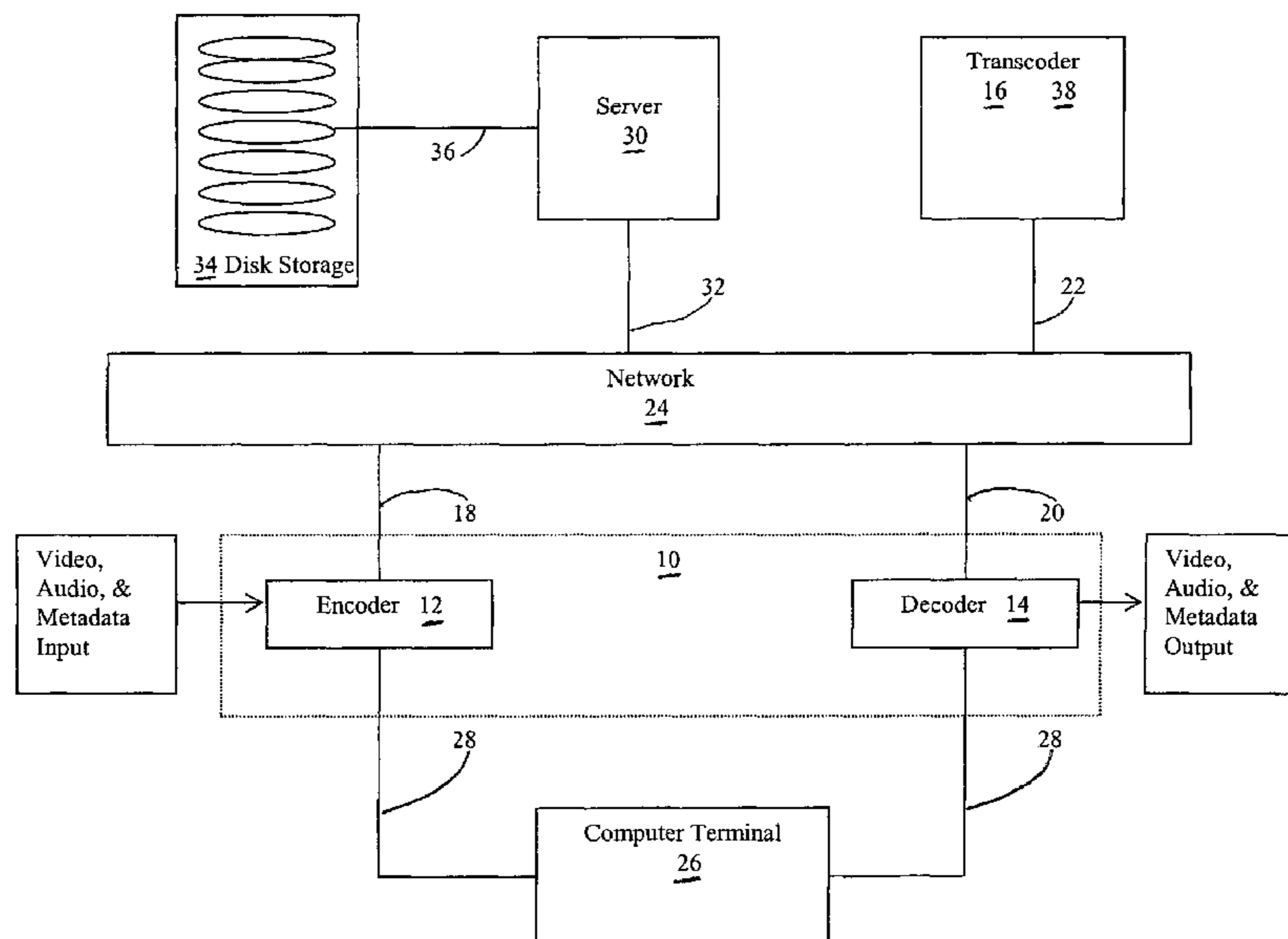

Related U.S. Application Data

continuation of application No. 10/916,330, filed on Aug. 10, 2004, now Pat. No. 8,621,542.

(60) Provisional application No. 60/494,396, filed on Aug. 11, 2003.

(51) **Int. Cl.**

- G06F 15/16** (2006.01)
- H04L 12/50** (2006.01)
- H04Q 11/00** (2006.01)
- H04N 21/2343** (2011.01)
- H04N 21/231** (2011.01)
- H04N 21/233** (2011.01)
- H04N 21/61** (2011.01)
- H04N 21/60** (2011.01)
- H04N 19/46** (2014.01)
- H04N 19/40** (2014.01)
- H04N 19/157** (2014.01)
- H04N 19/162** (2014.01)

(52) **U.S. Cl.**

CPC **H04N 19/40** (2014.11); **H04N 19/46** (2014.11); **H04N 21/231** (2013.01); **H04N 21/2335** (2013.01); **H04N 21/60** (2013.01); **H04N 21/6125** (2013.01)

(56) **References Cited**

U.S. PATENT DOCUMENTS

5,699,430 A * 12/1997 Krizay G07C 9/00182 340/5.26
 5,790,556 A * 8/1998 Matsumoto G11B 27/031 348/720
 5,818,512 A * 10/1998 Fuller H04N 7/17318 348/584
 5,995,553 A * 11/1999 Crandall G08B 25/085 375/272
 6,014,694 A * 1/2000 Aharoni et al. 709/219
 6,288,738 B1 * 9/2001 Dureau et al. 725/109
 6,487,720 B1 * 11/2002 Ohishi H04H 40/18 348/E7.063
 6,625,320 B1 * 9/2003 Nilsson et al. 382/238
 6,768,519 B2 * 7/2004 Fujita et al. 348/705
 7,046,251 B2 * 5/2006 Tarr et al. 348/575
 7,117,156 B1 * 10/2006 Kapilow G10L 19/005 370/281
 7,143,432 B1 * 11/2006 Brooks et al. 725/105
 7,239,703 B2 * 7/2007 Higurashi H04L 12/40104 369/47.1
 7,242,316 B2 * 7/2007 Scheelke H04L 12/2803 340/4.37
 7,266,611 B2 * 9/2007 Jabri et al. 709/231
 7,391,808 B1 * 6/2008 Farrand H04N 21/440218 375/240.02
 8,099,755 B2 * 1/2012 Bajpai et al. 725/94

8,214,567 B2 * 7/2012 Wu G11B 31/00 710/62
 2002/0007494 A1 * 1/2002 Hodge 725/109
 2002/0028024 A1 * 3/2002 Jayant et al. 382/243
 2002/0028670 A1 * 3/2002 Ohsuge H04M 1/6505 455/413
 2002/0059637 A1 * 5/2002 Rakib 725/119
 2002/0092030 A1 * 7/2002 Gu 725/134
 2002/0172281 A1 * 11/2002 Mantchala H04N 21/23412 375/240.12
 2002/0174442 A1 * 11/2002 Nomura 725/115
 2002/0196762 A1 * 12/2002 Choi et al. 370/338
 2003/0018983 A1 * 1/2003 Kawabata H04N 21/4147 725/151
 2003/0066084 A1 4/2003 Kaars
 2003/0123173 A1 * 7/2003 Blaum G11B 20/1426 360/48
 2003/0128301 A1 7/2003 Tarr et al.
 2003/0154480 A1 * 8/2003 Goldthwaite et al. 725/46
 2003/0177255 A1 * 9/2003 Yun 709/231
 2003/0185301 A1 10/2003 Abrams et al.
 2003/0233663 A1 12/2003 Rao et al.
 2004/0054689 A1 * 3/2004 Salmonsens et al. 707/104.1
 2004/0055016 A1 * 3/2004 Anipindi et al. 725/110
 2004/0237104 A1 * 11/2004 Cooper et al. 725/38
 2004/0246376 A1 * 12/2004 Sekiguchi et al. 348/468
 2004/0261113 A1 12/2004 Paul et al.
 2004/0264938 A1 12/2004 Felder
 2005/0044186 A1 2/2005 Petrisor
 2005/0144284 A1 * 6/2005 Ludwig H04L 12/58 709/226
 2006/0218611 A1 * 9/2006 Son et al. 725/105
 2007/0049306 A1 * 3/2007 Sekino H04W 28/06 455/502
 2009/0262741 A1 10/2009 Jungck et al.
 2011/0239258 A1 * 9/2011 Fisk et al. 725/81
 2014/0109144 A1 * 4/2014 Asnis H04N 21/43615 725/48

OTHER PUBLICATIONS

Anonymous, "Video Raptor," [Online] 2002, XP002307593, Retrieved from the Internet: URL:http://www.tiessecci.com/English/vr5000_engweb.pdf;[retrieved on Nov. 24, 2004].
 Anonymous, "One Source, Multi Use for Content Distribution in the Broadcast Era," Solution Blueprint Digital Media, [Online] 2002, XP002307594 Retrieved from the Internet: URL:<http://www.intel.com/business/bss/solutions/blueprints/pdf/isiddmam0235.pdf>;[retrieved].
 Anonymous, "FlipFactory," [Online] Mar. 2003 (Mar. 2003), XP002307595 Retrieved from the Internet: URL:<http://www.search/globalspec.com/goto/PDFViewer?pdfURL=http%3A%2F%2Fwww%2Evse%2Eut%2Fakkegatu%2FFF%5Fori%2Eodf%3E>;[retrieved].
 "Our New Standard!," JPEG 2000, <http://www.jpeg.org/jpeg2000/>.
 "GSN Overview," SGI, http://www.sgi.com/products/peripherals/networking/gsn_overview.html.
 Summons to attend oral proceedings pursuant to Rule 115(1) EPC dated Aug. 18, 2014 for EP04780741.7.

* cited by examiner

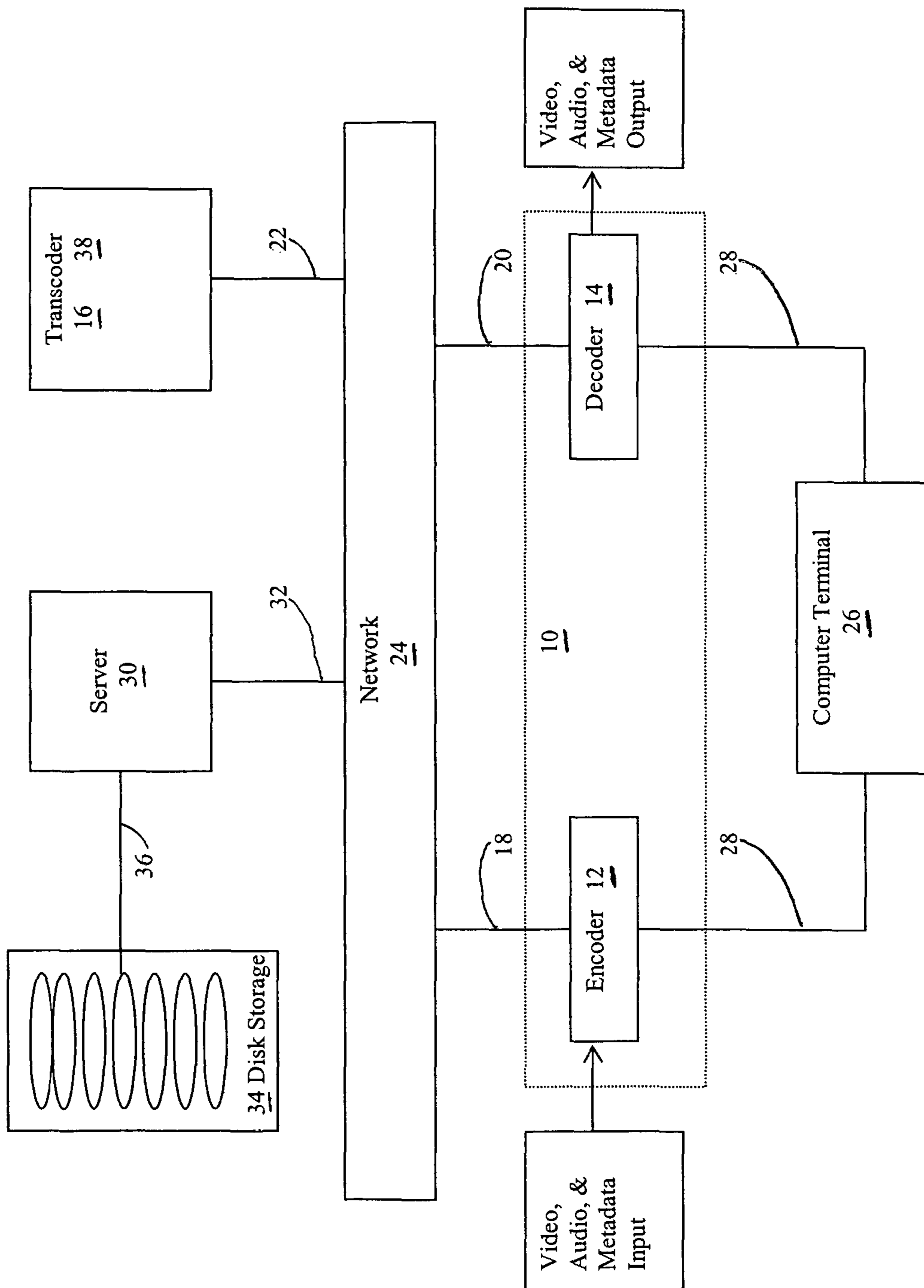

DIGITAL MEDIA DISTRIBUTION DEVICE**CROSS-REFERENCE TO RELATED APPLICATION**

This application is a continuation of U.S. application Ser. No. 14/144,462 filed Dec. 30, 2013, now U.S. Pat. No. 8,904,466, which is continuation of Ser. No. 10/916,330 filed Aug. 10, 2004, now U.S. Pat. No. 8,621,542, which claims priority under 35 U.S.C. §119(e) to U.S. Provisional Patent Application No. 60/494,396, filed on Aug. 11, 2003, entitled "Digital Media Distribution Device," by Paul Klamer, Ken Long, and Arjun Ramamurthy, which applications are incorporated by reference herein.

BACKGROUND OF THE INVENTION**Field of the Invention**

The invention relates generally to the field of data manipulation and storage. More specifically, the invention relates to devices that manipulate and store image, sound, and associated metadata.

Description of Related Art

In the entertainment industry, the video tape recorder ("VTR") has served for many years as the main device for storing video and accompanying audio. However, there is a need for an apparatus that provides capabilities beyond those offered by the VTR. In particular, there is a need for an apparatus that can store data on network-accessible mass storage devices, e.g., disk drives. Additionally, there is a need for an apparatus that can transcode data between different data formats. Accordingly, there is a need for an apparatus that can store data on network-accessible storage devices and transcode data between formats. The present invention satisfies these needs.

SUMMARY OF THE INVENTION

Embodiments of the present invention include a digital media distribution device that includes an encoder, a decoder, and a transcoder, which transcodes between data formats. The digital media distribution device interfaces with a shared storage device for data storage. An exemplary embodiment of the present invention is a digital media distribution device that includes an encoder, a decoder coupled to the encoder, and a transcoder coupled to the decoder. The encoder is configured to encode input data that is received by the digital media distribution device into a first data format. The decoder is configured to decode output data to be output by the digital media distribution device. The transcoder is configured to convert the encoded input data from the first data format into a second data format. The digital media distribution device is configured to be coupled to a computer network.

In other, more detailed features of the invention, the encoder and decoder are housed within a single electronics rack. The electronics rack includes a hardware slot, and an interface board that is configured to insert into the hardware slot. The interface board supports an interface format selected from the group consisting of SD-SDI, HD-HDI, GSN, uncompressed AES-3, unbalanced BNC, and balanced XLR. Also, the encoder and decoder are remote controllable. In addition, a computer terminal unit is coupled to the encoder and the decoder.

In other, more detailed features of the invention, the encoder and the decoder perform a verification check and report their status to a user before processing data. In

addition, the encoder is configured to calculate a peak signal-to-noise ratio value when the encoder and the decoder are coupled in a closed-loop configuration. In addition, the transcoder is implemented in software on a personal computer. Furthermore, the transcoder includes a PCI accelerator board having ASIC accelerators. Also, the transcoder converts between data formats selected from the group consisting of JPEG2000, MPEG-2, minimally ATSC (high definition), DVD elemental bit stream, DVB (625), and 4:2:2.

In other, more detailed features of the invention, the digital media distribution device is configured for wavelet-based tunable compression. Also, the digital media distribution device has a form factor and a user interface that approximate the form factor and the user interface for a video tape recorder. In addition, the digital media distribution device includes a codec and an operating system, and the codec and the operating system can be upgraded by a user. Furthermore, the encoder encodes data at an encoding bit rate, the decoder decodes data at a decoding bit rate, and the encoding bit rate and the decoding bit rate are user definable.

In other, more detailed features of the invention, the digital media distribution device is an internet protocol addressable device. Also, the digital media distribution device is coupled to the computer network, and the digital media distribution device is coupled to a network-accessible storage device via the computer network. Furthermore, the encoder, the decoder, and the transcoder each include cache memory used to compensate for latency associated with accessing the network-accessible storage device. Also, the digital media distribution device is coupled to an asset management system, and the asset management system can determine end of file location information and asset information for the data.

Other features of the invention should become apparent from the following description of the preferred embodiments taken in conjunction with the accompanying drawing, which illustrates, by way of example, the principles of the invention.

BRIEF DESCRIPTION OF THE DRAWINGS

The FIGURE is a block diagram of a digital media distribution device according to a preferred embodiment.

DETAILED DESCRIPTION OF THE PREFERRED EMBODIMENTS

Referring to the FIGURE, embodiments of the present invention are included in a digital media distribution device ("DMD device") **10** that compresses input data for storage and decompresses stored data to be output from the DMD device. The DMD device includes an encoder **12**, which compresses the input data received from an external device (not shown), e.g., film scanner; a decoder **14**, which decompresses the data for output while preserving color matrices and properly adjusting the image size; and a transcoder **16**, which converts the data between various data formats.

The encoder **12** and decoder **14** are rack-mountable and can be housed within a single electronics rack (not shown), or in two separate electronics racks (not shown) for playback-only or record-only configurations, and can be remotely controlled using various remote control formats, e.g., Sony RS-422 VTR control. The encoder, decoder, and transcoder **16** are coupled, via interface lines **18**, **20**, and **22**, respectively, e.g., fiber or copper Ethernet interfaces, to a computer network **24**, e.g., Ethernet. Accordingly, the

encoder is coupled to the decoder via the computer network. Also, a computer terminal unit **26** is coupled to both the encoder and the decoder via RS-232 lines **28** that couple to RS-232 ports (not shown) on the encoder and decoder. The computer terminal unit allows an operator to control the decoder and the encoder. Also, the computer terminal unit can be network assignable so it can be physically separated from the encoder and the decoder.

A server **30**, e.g., a New Technology (“NT”) server or a Unix box, is coupled to the computer network **24** via a server interface line **32**, and a network accessible data storage device **34** is coupled to the server via a storage device interface line **36**. The data storage device can be any of the standard storage devices known in the art. While the FIGURE depicts one server and network storage device, more than one server and more than one network storage device can be coupled to the computer network and accessed by the DMD device **10**.

The DMD device **10** is a network addressable device, e.g., an Internet protocol (“IP”) addressable device, thus the DMD device permits remote access via the computer network **24** for configuration, operation, diagnostics, and upgrades. The DMD device is designed to utilize database standards, e.g. SQL, and thus can interface with a standard database server **30**. The operating system (“OS”) for the DMD device can be any open and customizable OS, e.g., Linux.

Both the encoder **12** and the decoder **14** each include a front-end module (not shown), a mid-region module (not shown), and a back-end module (not shown). Encoder’s front-end module interfaces with the computer network **24** and receives input signals from the computer network. The encoder’s front-end module includes slots (not shown) into which various interface cards can be inserted to handle different input formats, e.g., high definition (“HD”), standard definition (“SD”), and gigabyte system network (“GSN”). The encoder transfers the data received by the encoder’s front-end module to the encoder’s mid-region module where the data is compressed. After the data is compressed, the encoder transfers the compressed data to the encoder’s back-end module, which transfers the compressed data via the computer network and the server **30** to the network storage device **34**.

The decoder’s back-end module (not shown) interfaces with the computer network **24** and receives data from the network storage device **34** via the server **30**. Next, the decoder **12** transfers the compressed data from the back-end module to the mid-region module where the compressed data is decompressed. Finally, the decoder transfers the decompressed data from the mid-region module to the decoder’s front-end module which outputs the data, e.g., SD or HD video data, to the user based on the user-defined configuration.

Both the encoder **12** and the decoder **14** are of a modular building block configuration, which allows for the expansion of encoder and decoder capability. As mentioned previously, the encoder and the decoder are rack-mountable, each with a maximum foot print of two rack units (“RUs”). The rack space for the combination of all of the encoder modules (not shown) and the decoder modules (not shown) can extend, for example, to a total of six RUs.

Both the encoder’s front end module (not shown) and the decoder’s front-end module (not shown) include reconfigurable hardware slots into which various interface boards, e.g., Ethernet board including either fiber or copper interfaces, can be installed to handle various input types (encoder) and output types (decoder). Since the interface type

for both the encoder’s front-end module and decoder’s front end module can be reconfigured, the encoder and decoder can be customized to match the desired interface type. In particular, the interface type for both the encoder’s front-end module and the decoder’s front-end module can be reconfigured to support an SD (e.g., NTSC standard=525 lines or PAL standard=625 lines) serial data input (“SD-SDI”) stream, an HD (e.g., 1920 by 1080 interlaced pixels) serial data input (“HD-SDI”) stream, or an optical GSN stream.

In one example, the encoder’s front-end module (not shown) and/or the decoder’s front-end module (not shown) can be configured to include dual 292 HD-SDI interfaces, five audio channels interfaces, and a time code interface. Embodiments that include dual HD-SDI advantageously provide full color, i.e., red, green, blue data (“RGB”) at 4:4:4, rather than sub-sampled color, i.e., RGB at 4:2:2, which is provided when the interfaces are single HD-SDI interfaces. In another example, the encoder’s front-end module or the decoder’s front-end module includes 48 audio channels interfaces. In yet another example, both the encoder’s front-end module and the decoder’s front-end module are configured with SD-SDI, HD-SDI SMPTE **292**, and 8 audio channel interfaces such that both the encoder and the decoder have a combined front-end module bandwidth of 3.5 gigabits per second and a combined back-end module bandwidth of at least 1 gigabit per second.

Furthermore, the slots (not shown) in the encoder’s front-end module (not shown) and the decoder’s front-end module (not shown) can be configured to include interfaces for encoding/decoding audio data, which can be in various audio formats, e.g., uncompressed AES-3, unbalanced BNC, and balanced XLK. Both the encoder **12** and the decoder **14** can also handle embedded audio in 292 or 601 bit stream configurations. The implemented audio file format should be lossless with a mechanism to sync with the corresponding video format for transcoding and decoding. An example audio format supports a 96 kHz sample rate and a 32-bit depth.

Both the encoder **12** and the decoder **14** include a time code that supports the linear time code (“LTC”) and vertical interlaced time code (“VITC”) standards, including drop frame/non-drop frame. For the decoder, both an analog timecode and a digital timecode are available over an RS-422 serial port. Also, the decoder supports error concealment, for on-air use, and provides for disabling error concealment, for mastering. The user has the ability to turn the concealment on and off. Also, the decoder supports standard VTR functionality, for example, jog dial playback, pause, and rewind. In addition, the decoder supports the ability to adjust the size, aspect ratio, and resolution of an image.

Before the encoder **12** and the decoder **14** are used, the encoder and the decoder perform a file system performance verification check and report their statuses to the user. Also, the encoder and the decoder report their ability to perform proper encoding and decoding based on the statuses of their boot batteries and the results of bandwidth tests. The boot battery is the internal battery source included in both the encoder and the decoder that is used to power memory devices, e.g., EEPROMs, that hold the boot information for the encoder or decoder. Also, both the encoder and the decoder can perform video/audio diagnostic capability checks such as tone and test pattern reading.

The encoder **12** and the decoder **14** can be coupled in a closed-loop configuration (not shown). In the closed-loop

5

configuration, the encoder can calculate a value of peak signal-to-noise ratio (“PSNR”) according to the following equation:

$$\text{PSNR} = 20 \log(\text{RMS error}),$$

where the RMS error is the square root of the squared value of the encoder-decoder system’s average error measured by the encoder squared.

The PSNR value is output to the user on the computer terminal unit **26** and can be monitored by the user or a remote device (not shown) and used to determine if the quality of the encoding is sufficient, or if the encoding bit rate needs to be adjusted.

The transcoder **16** is housed within a personal computer **38** and can be implemented as a software module that can run on more than one computer. Furthermore, the transcoder can incorporate a peripheral component interconnect (“PCI”) accelerator board (not shown) with Application Specific Integrated Circuit (“ASIC”) accelerators for improved performance. The transcoder utilizes a database, e.g., an SQL-compliant database, for job actions, and processes transcoding jobs according to a customizable priority structure. More specifically, the transcoder handles job delegation, queuing, prioritization, delivery, and hand-off. The transcoder delivers transcoded output to the network storage device **34** via the computer network **24**.

User interaction with the transcoder **16** is implemented via a graphical user interface (“GUI”) and command line interface (“CLI”). Through the GUI, users can select a data file to transcode and submit the job for processing. The GUI is generic, able to run on multiple platforms, and is customizable to support the creation of interfaces for different job functions. The transcoder also is able to accept transcoding commands via a command line interface (“CLI”) through a remote shell (“RSH”), which allows for remote login to the transcoder.

The transcoder **16** can transcode between various data formats, e.g., JPEG2000, MPEG-2, minimally ATSC (high definition), DVD elemental bit stream, DVB (625), and 4:2:2, with full user configurability on transcode options. Also, the transcoder allows the user to adjust the bit rates, frame rates, resolution, broadcast format, GOP structures, audio repackaging, and syncing schemes of the data. The transcoder processes intermediate RGB data and add burn-in elements. Also, the transcoder converts different field orders (both lower and upper). The transcoder can output asset recreation instructions (“metadata”) so that the transcoded version of the data can be recreated if demanded. The transcoder can first store the transcoded output data to the network storage device **34**, and then forward the transcoder’s output to another device (not shown), e.g., additional disk storage.

All storage of data for the encoder **12**, decoder **14**, and transcoder **16**, is accomplished using the network storage device **34**, which is accessible over the computer network **24** through the server **30**. The encoder, decoder, and transcoder all include cache memory (not shown), which is used to compensate for latency associated with accessing the network storage device. The size of the cache memory in each of the encoder, the decoder, and the transcoder is sufficient to prevent lag during high-latency conditions. File systems, e.g., common internet file system (CIFS/SMB) or network file system interface-NFS-V3, are included in the DMD device **10** that support the storage of encoded files to the network storage device. The DMD device can also include a hierarchical storage management (“HSM”) system (not

6

shown) via standard HSM protocols, or even Extensible Markup Language (“XML”) tags, which control the storage of the encoded data.

Furthermore, the DMD device **10** has the ability to communicate with an asset management system (not shown), which permits the user to track and manage the data (“the asset”). The asset management system can be used to determine the end file location information and asset identification of the data. In one example, an asset management system could be used to locate where a specific take of a scene in a film is stored in the network data storage device **34**.

Advantageously, the DMD device **10** according to the present invention, in addition to functioning as a VTR, has a form factor and user interface that is similar to, approximate, that of a VTR. The DMD device can operate either as a stand-alone device or a network-accessible device. When the DMD device is coupled to a computer network **24**, the DMD device can benefit from backup servers (not shown) that provide data in the event of a failure of the network data storage device **34**. Also, the DMD device advantageously includes an output mechanism that indicates the status and configuration of the encoder **12** and the decoder **14**. For example, the DMD device can measure the boot battery value and bandwidth of the encoder and decoder prior to use. When power is applied to the encoder and decoder, the encoder and decoder use their boot battery for initialization purposes, and the encoder and decoder measure the available network bandwidth and characterize the computer network throughput and performance based on the current network bandwidth and usage. This information is output to the user via a monitoring device, e.g., the computer terminal unit **26**.

Another advantage of the DMD device **10** is that the codec and OS are upgradeable in both the encoder **12** and decoder **14** since the OS is stored on Flash ROM (not shown) and the codec is implemented using a pin grid array (“PGA”) based architecture (not shown). The codec and the OS can be upgraded in the server mode, where the DMD device checks for updates from a server, via the computer network, and then proceeds to operation. Alternatively, the codec and the OS can be upgraded in the stand alone mode, where updates can be administered through the computer terminal unit **26**. Furthermore, the computer terminal unit can communicate with the encoder or decoder in case of boot failures, notifications, or status messages. The encoder or decoder can be instructed, via the computer terminal unit, through command line interface (“CLI”) scripts. Also, CLI scripts can be used to control the transcoder.

Advantageously, the DMD device **10** can support the encoding and decoding of data files at bit rates set in user-definable profiles (not shown). The profiles are stored on the server **30** and can be accessed by a remote user when changing the bit rate for a specific input job. The bit rate can change from lossless to lossy, which could be from no degradation to absolute degradation in image quality. Also, the bit rate can be different between the bit rate input to the DMD device and the bit rate output from the DMD device, if the input bit rate is 10 bits per pixel, the output can vary from 10 bits per pixel (no loss) down to 0.1 bit per pixel (lossy). Furthermore, the digital media distribution device provides for wavelet-based tunable compression, for example, with JPEG2000 data.

The foregoing detailed description of the present invention is provided for purposes of illustration, and it is not intended to be exhaustive or to limit the invention to the particular embodiments disclosed. The embodiments can provide different capabilities and benefits, depending on the

configuration used to implement the key features of the invention. Accordingly, the scope of the invention is defined only by the following claims.

The invention claimed is:

1. A digital media distribution device comprising:
 - an encoder that is configured to encode input data that is received by the digital media distribution device into a first data format, the encoder coupled directly to and under control from a computer terminal unit;
 - a decoder, coupled to the encoder via a computer network, that is configured to decode output data to be output by the digital media distribution device, the decoder coupled directly to and under control from the computer terminal unit; and
 - a transcoder, coupled to the decoder, that is configured to convert the encoded input data from the first data format into a second data format; and
 the computer terminal unit enabling an operator to directly control the encoder and the decoder using a remote control format via one of a serial connection or the computer network, wherein the encoder is coupled to the decoder solely by the computer network, and the transcoder is coupled to the decoder and to the encoder via the computer network.
2. The digital media distribution device according to claim 1, wherein the encoder and the decoder are remotely controllable.
3. The digital media distribution device according to claim 1, wherein the encoder and the decoder perform a verification check and report their status to a user before processing data, including reporting decoding and encoding capability based on a bandwidth test.
4. The digital media distribution device according to claim 1, wherein the digital media distribution device is configured for wavelet-based tunable compression.
5. The digital media distribution device according to claim 1, wherein the digital media distribution device has a form factor and a user interface that approximate the form factor and the user interface for a video tape recorder.
6. The digital media distribution device according to claim 1, wherein:
 - a. the encoder encodes data at an encoding bit rate;
 - b. the decoder decodes data at a decoding bit rate; and
 - c. the encoding bit rate and the decoding bit rate are user definable.
7. The digital media distribution device according to claim 1, wherein the digital media distribution device is an internet protocol addressable device.
8. The digital media distribution device according to claim 1, wherein:

the digital media distribution device is coupled to a network-accessible storage device via the computer network, the network-accessible storage device configured to store all encoded data for at least one of the encoder and the decoder.
9. The digital media distribution device according to claim 1, wherein the encoder, the decoder, and the transcoder each include cache memory used to compensate for latency associated with accessing the network-accessible storage device.
10. The digital media distribution device according to claim 1, wherein the digital media distribution device is coupled to an asset management system, and the asset management system can determine end of file location information and asset information for the data.

11. The digital media distribution device according to claim 1, further comprising a hardware reconfigurable compression codec operatively associated with at least one of the encoder and the decoder.

12. The digital media distribution device according to claim 1, wherein the encoder and the decoder comprise hardware slots configured to support multiple interface formats including at least two selected from the group consisting of SD-SDI, HD-HDI, GSN, uncompressed AES-3, unbalanced BNC, and balanced XLR.

13. A digital media distribution device comprising:

- an encoder that is configured to encode input data that is received by the digital media distribution device into a first data format, the encoder coupled directly to and under control from a computer terminal unit; and
- a decoder, coupled to the encoder via a computer network, that is configured to decode output data to be output by the digital media distribution device, the decoder coupled directly to and under control from the computer terminal unit; and

 the computer terminal unit enabling an operator to directly control the encoder and the decoder using a remote control format via one of a serial connection or the computer network, wherein the encoder is coupled to the decoder solely by the computer network.

14. The digital media distribution device according to claim 13, wherein the encoder and the decoder perform a verification check and report their status to a user before processing data, including reporting decoding and encoding capability based on a bandwidth test.

15. The digital media distribution device according to claim 13, wherein the digital media distribution device is configured for wavelet-based tunable compression.

16. The digital media distribution device according to claim 13, wherein the digital media distribution device has a form factor and a user interface that approximate the form factor and the user interface for a video tape recorder.

17. The digital media distribution device according to claim 13, wherein:

- d. the encoder encodes data at an encoding bit rate;
- e. the decoder decodes data at a decoding bit rate; and
- f. the encoding bit rate and the decoding bit rate are user definable.

18. The digital media distribution device according to claim 13, wherein the digital media distribution device is an internet protocol addressable device.

19. The digital media distribution device according to claim 13, wherein:

the digital media distribution device is coupled to a network-accessible storage device via the computer network, the network-accessible storage device configured to store all encoded data for at least one of the encoder and the decoder.

20. The digital media distribution device according to claim 13, wherein the encoder and the decoder each include cache memory used to compensate for latency associated with accessing the network-accessible storage device.

21. The digital media distribution device according to claim 13, wherein the digital media distribution device is coupled to an asset management system, and the asset management system can determine end of file location information and asset information for the data.

22. The digital media distribution device according to claim 13, further comprising a hardware reconfigurable compression codec operatively associated with at least one of the encoder and the decoder.

23. The digital media distribution device according to claim 13, wherein the encoder and the decoder comprise hardware slots configured to support multiple interface formats including at least two selected from the group consisting of SD-SDI, HD-HDI, GSN, uncompressed AES- 5
3, unbalanced BNC, and balanced XLR.

* * * * *