



US009675004B2

(12) **United States Patent**
Landphair et al.

(10) **Patent No.:** **US 9,675,004 B2**
(45) **Date of Patent:** **Jun. 13, 2017**

(54) **SOIL MOISTURE-BASED PLANTER**
DOWNFORCE CONTROL

8,522,889 B2 9/2013 Adams et al.
8,924,092 B2 12/2014 Achen et al.
9,232,687 B2 1/2016 Bassett

(71) Applicant: **Deere & Company**, Moline, IL (US)

(Continued)

(72) Inventors: **Donald K. Landphair**, Moline, IL (US); **Michael E. Frasier**, Iowa City, IA (US); **James Z. Liu**, Moline, IL (US); **Jason D. Walter**, Bettendorf, IA (US); **Lawrence D. Green**, Bettendorf, IA (US)

FOREIGN PATENT DOCUMENTS

WO 2013066652 5/2013
WO 2014153157 9/2014

(Continued)

OTHER PUBLICATIONS

(73) Assignee: **Deere & Company**, Moline, IL (US)

Hanna, et. al., Applied Engineering in Agriculture, vol. 26(4): pp. 551-556, (2010) American Society of Agricultural and Biological Engineers ISSN 0883-8542.

(*) Notice: Subject to any disclaimer, the term of this patent is extended or adjusted under 35 U.S.C. 154(b) by 0 days.

(Continued)

(21) Appl. No.: **14/871,476**

Primary Examiner — Thomas Tarcza

(22) Filed: **Sep. 30, 2015**

Assistant Examiner — Alex C Dunn

(65) **Prior Publication Data**

US 2017/0086361 A1 Mar. 30, 2017

(74) *Attorney, Agent, or Firm* — Michael Best & Friedrich LLP

(51) **Int. Cl.**
A01C 7/20 (2006.01)
A01C 5/06 (2006.01)

(57) **ABSTRACT**

(52) **U.S. Cl.**
CPC **A01C 7/205** (2013.01); **A01C 5/062** (2013.01); **A01C 5/068** (2013.01); **A01C 7/203** (2013.01)

A seeding machine includes a main frame, and a row unit coupled to the main frame. The row unit has a row unit frame, a gauge wheel coupled to the row unit frame, and a furrow opener coupled to the row unit frame, the furrow opener having a stationary or rotating surface that contacts and moves soil. The row unit also includes a furrow closer, the furrow closer having a stationary or rotating surface that contacts and presses soil. The seeding machine also includes a downforce adjustment system for adjusting an amount of downforce applied to the row unit, the downforce adjustment system including a moisture sensor, a controller configured to receive a signal from the moisture sensor, and an actuator configured to change the amount of downforce applied to the row unit based on the signal received by the controller.

(58) **Field of Classification Search**
CPC **A01C 5/062**; **G05B 15/02**
See application file for complete search history.

(56) **References Cited**

U.S. PATENT DOCUMENTS

7,630,806 B2 * 12/2009 Breed B60R 21/0134
180/273

17 Claims, 2 Drawing Sheets

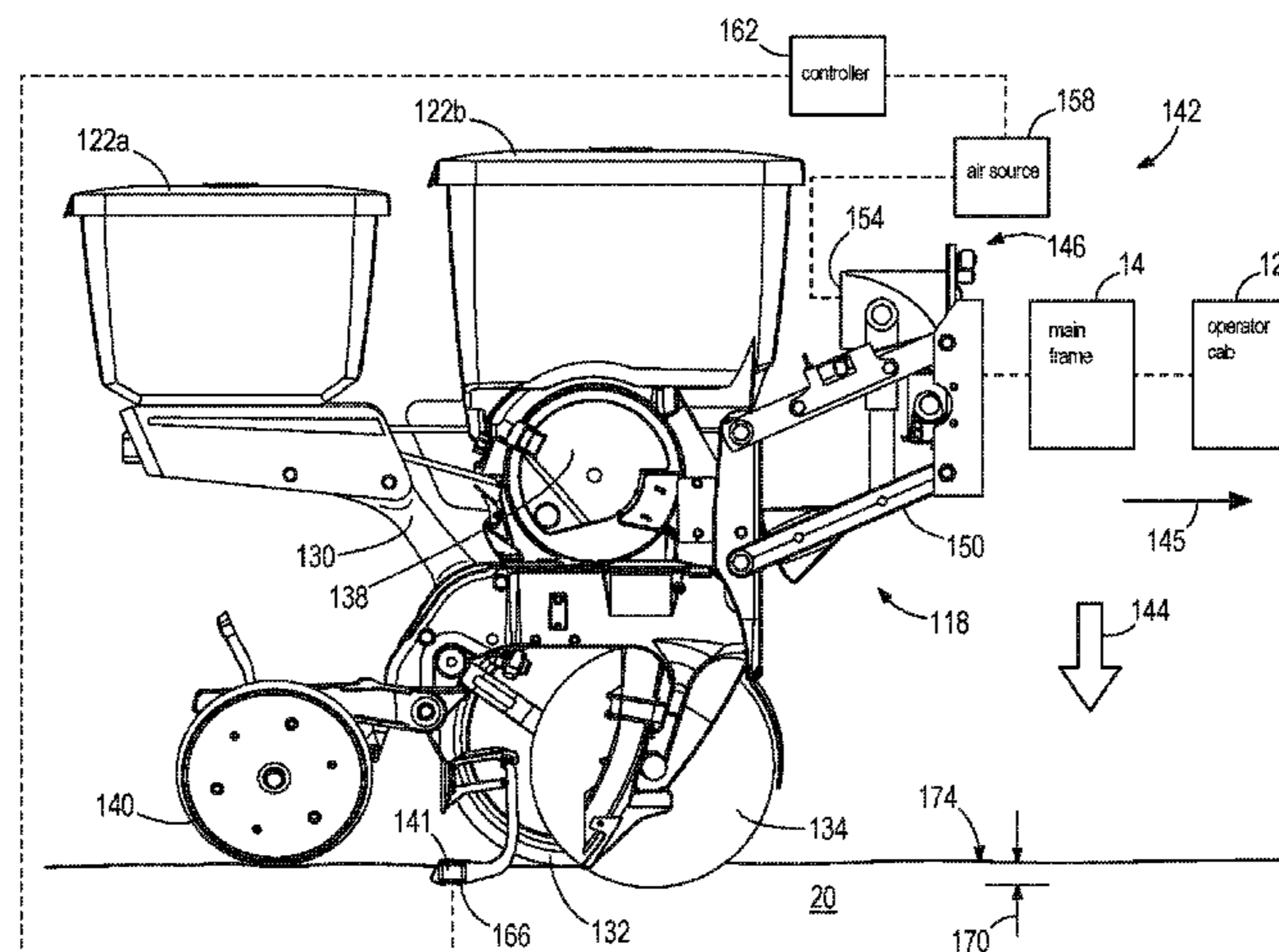

(56)

References Cited

U.S. PATENT DOCUMENTS

2009/0164067 A1* 6/2009 Whitehead A01B 79/005
701/41
2011/0126746 A1* 6/2011 Borland A01C 5/04
111/149
2012/0083907 A1* 4/2012 Motavalli G06Q 10/0631
700/90
2014/0303854 A1 10/2014 Zielke
2014/0379228 A1* 12/2014 Batcheller A01C 21/005
701/50
2015/0066932 A1* 3/2015 Stuber G06Q 50/02
707/737
2015/0105965 A1* 4/2015 Blackwell A01B 59/002
701/28
2015/0264857 A1 9/2015 Achen et al.
2015/0289441 A1 10/2015 Arnett et al.

2015/0296698 A1 10/2015 Schumacher et al.
2016/0037709 A1* 2/2016 Sauder A01C 7/203
700/275

2016/0116632 A1 4/2016 Stoller et al.
2016/0338260 A1 11/2016 Hahn et al.

FOREIGN PATENT DOCUMENTS

WO 2015143433 9/2015
WO 2015171908 A1 11/2015

OTHER PUBLICATIONS

EP16190940.3 Extended European Search Report dated Feb. 7, 2017 (9 pages).
Office Action from the United States Patent and Trademark Office for U.S. Appl. No. 14/871,458 dated Jan. 13, 2017 (12 pages).

* cited by examiner

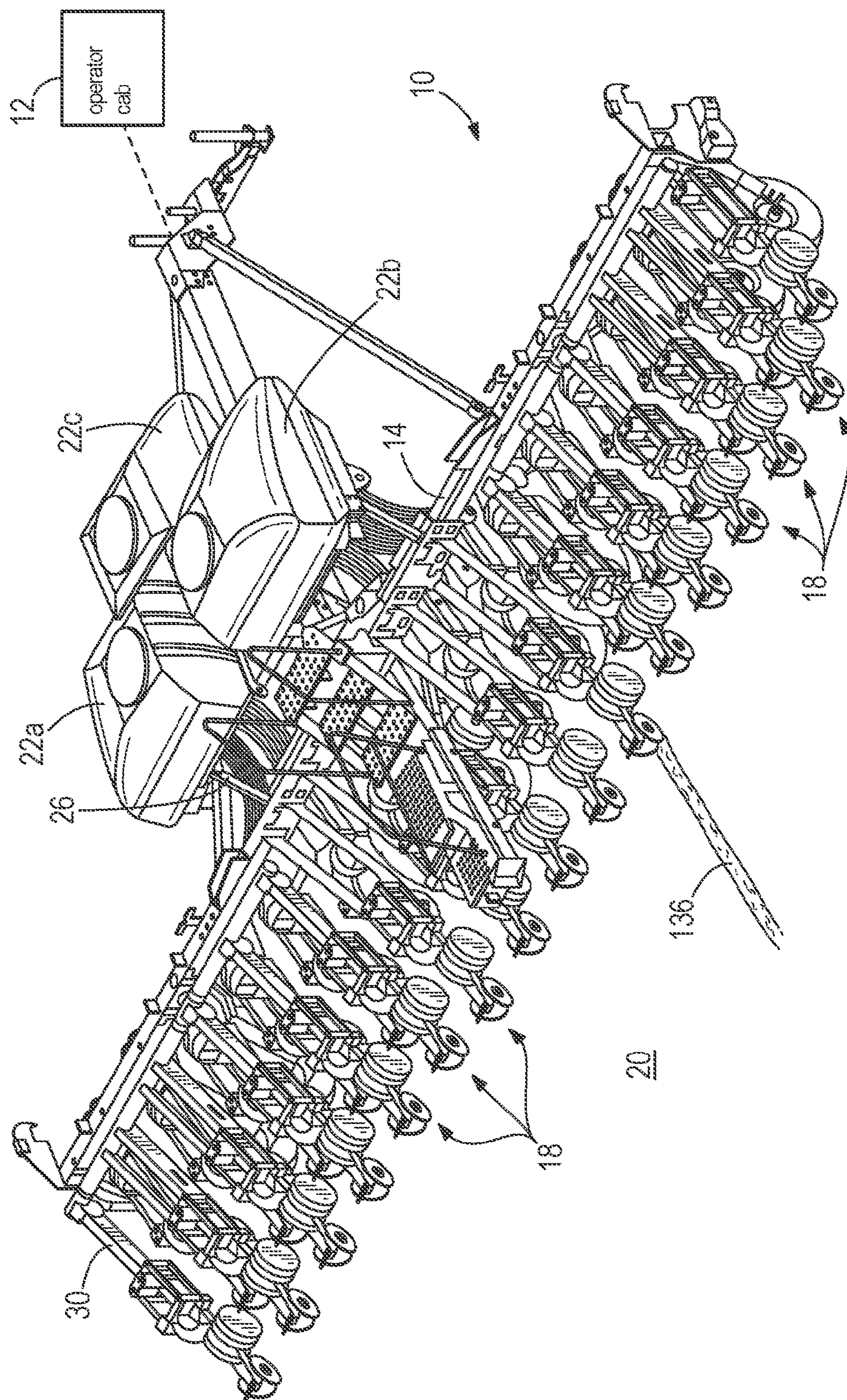

FIG. 1

1

SOIL MOISTURE-BASED PLANTER
DOWNFORCE CONTROL

BACKGROUND

The present disclosure relates to systems and methods for planting seeds, in particular with a row crop planter.

Various factors affect crop yields. Such factors include, for example, seed depth, seed spacing, soil compaction, soil moisture, tillage condition, soil nutrients, and soil type. A productive crop yield is typically one that grows and emerges uniformly from the soil.

SUMMARY

In one aspect, the disclosure provides a seeding machine that includes a main frame, and a row unit coupled to the main frame. The row unit has a row unit frame, a gauge wheel coupled to the row unit frame, and a furrow opener coupled to the row unit frame, the furrow opener having a stationary or rotating surface that contacts and moves soil. The row unit also includes a furrow closer coupled to the row unit frame, the furrow closer having a stationary or rotating surface that contacts and presses soil. The seeding machine also includes a downforce adjustment system for adjusting an amount of downforce applied to the row unit, the downforce adjustment system including a moisture sensor configured to detect a moisture level of soil, a controller configured to receive a signal from the moisture sensor corresponding to the detected moisture level, and an actuator configured to change the amount of downforce applied to the row unit based on the signal received by the controller.

In another aspect, the disclosure provides a seeding machine that includes a controller having a processor configured to detect a moisture level with a moisture sensor coupled to a row unit on the seeding machine, determine whether the moisture level is above a predetermined threshold, and in response to determining that the moisture level is above a predetermined threshold, decrease a downforce on the row unit.

In another aspect, the disclosure provides a seeding machine that includes a main frame, and a row unit coupled to the main frame. The row unit has a row unit frame. The seeding machine also includes a downforce adjustment system coupled to the row unit for adjusting an amount of downforce applied to the row unit. The downforce adjustment system includes a moisture sensor coupled to the row unit and configured to detect a moisture level of one or more layers of soil, the moisture sensor selected from a group consisting of a capacitive sensor, an infrared sensor, and a radar sensor. The downforce adjustment system also includes a controller configured to receive a signal from the moisture sensor corresponding to the detected moisture level, and an actuator configured to change the amount of downforce applied to the row unit based on the signal received by the controller. The actuator includes an air bag and an air source coupled to the air bag, the air source configured to provide air to the air bag. The downforce adjustment system also includes a linkage coupled to each of the air bag, the row unit frame, and the main frame, wherein the linkage is pivotally coupled to the main frame.

Other aspects of the disclosure will become apparent by consideration of the detailed description and accompanying drawings.

BRIEF DESCRIPTION OF THE DRAWINGS

FIG. 1 is a partially schematic perspective view of a seeding machine.

2

FIG. 2 is a partially schematic side view of a row unit for the seeding machine of FIG. 1.

DETAILED DESCRIPTION

Before embodiments of the disclosure are explained in detail, it is to be understood that the disclosure is not limited in its application to the details of construction and the arrangement of components set forth in the following description or illustrated in the accompanying drawings. The disclosure is capable of supporting other embodiments and of being practiced or of being carried out in various ways.

FIG. 1 illustrates a seeding machine 10 (e.g., a row crop planter). The seeding machine 10 includes a main frame 14 and is pulled behind a tractor (not shown) having an operator's cab 12 (shown schematically). A plurality of individual row units 18 are coupled (e.g., mounted) on a rear portion of the main frame 14, such that the row units 18 are pulled over a layer of soil 20. Seed sources, such as storage tanks 22a-22c, are coupled to the main frame 14, and hold seed that is delivered, e.g., pneumatically or in any other suitable manner, to a mini-hopper (not shown) on each row unit 18. The storage tanks 22a-22c are coupled to the mini-hoppers by way of conduits 26, such as hoses, and a pressurized delivery apparatus (not shown). Each storage tank 22a-22c contains the same or different varieties of seed to be planted in the soil 20. Each row unit 18 is connected to a conduit 26 such that each row unit 18 is coupled to a storage tank 22a-22c to receive seed. As illustrated in FIG. 1, each row unit 18 further includes its own frame 30, to which various components (e.g., a furrow opener, a furrow closer, etc.) are mounted.

FIG. 2 illustrates an example of a row unit 118 that may be used in place of one of the row units 18 in FIG. 1. Similar to the row unit 18, the row 118 is also coupled to the main frame 14. In some constructions, a plurality of row units 118 are coupled to the main frame 14, similar to the row units 18 in FIG. 1.

As illustrated in FIG. 2, each row unit 118 includes its own hoppers 122a, 122b that hold chemical and seed respectively rather than receiving seed from bulk storage as in the construction illustrated in FIG. 1. The hoppers 122a, 122b are coupled to a row unit frame 130. Each row unit 118 also includes a gauge wheel (or wheels) 132 coupled to the row unit frame 130 that contacts and rolls along the soil 20, and a furrow opener 134 (e.g., an opening wheel or blade or other structure having a stationary or rotating surface that contacts and moves soil away to form a furrow) coupled to the row unit frame 130 for forming a furrow 136 (see FIG. 1) in the soil 20. A seed metering device 138 coupled to the row unit frame 130 receives seeds from hopper 122b and meters and dispenses the seeds into the furrow 136. A furrow closer 141 (e.g., a closing and packing wheel or wheels or other structure having a stationary or rotating surface that contacts and presses soil) coupled to the row unit frame 130 pushes soil around the seeds to close the furrow 136. In the illustrated construction, each row unit 118 also includes a seed firmer device 141 coupled to the row unit frame 130 forward of the closer 141 that firms each seed and pushes it into the opened furrow 136.

With continued reference to FIG. 2, the row unit 118 further includes a downforce adjustment system 142. The downforce adjustment system 142 adjusts an amount of downforce that is applied to the row unit 118 (e.g., to the gauge wheel or wheels 132) to control a seed planting depth. Downforce refers to an amount of force applied downwardly

(see the arrow **144** in FIG. **2**) in a direction perpendicular relative to the soil **20** and to a direction of movement **145** of the seeding machine **10**.

The downforce adjustment system **142** includes an actuator **146** that when activated changes the downforce on the row unit **118**. In the illustrated construction, a linkage **150** couples the row unit **118** to the main frame **14**. A downforce actuator **146** is coupled to main frame **14** and the linkage **150**. When activated, the actuator **146** drives the linkage **150** downwardly, causing an increase in downforce on the row unit frame **130** and on the overall row unit **118**. When the downforce is increased, the downforce presses the gauge wheel **132** into the soil **20**. Thus, when the downforce is increased, the resulting planted seeds are typically planted at a deeper depth. Conversely, when the downforce is decreased, the resulting planted seeds are typically planted at a shallower depth. In some constructions the actuator **146** may be double acting and can provide an up-force to lift the row unit if the row unit weight is more needed for the conditions.

In the illustrated construction, the actuator **146** is a pneumatic actuator that includes an air bag **154** and an air source **158** (e.g., a compressor, a motor, etc.). The air source **158** may be located on the row unit **118** itself, on the main frame **14**, or on the towing tractor. When the actuator **146** is activated, the force applied to the linkage **150** rotates the linkage downward relative to the main frame **14** (counterclockwise in FIG. **2**), causing the gauge wheel **132** to press down more firmly into the soil **20** below.

In some constructions, the actuator **146** is a hydraulic actuator (e.g., including a hydraulic cylinder and rod coupled to the main frame **14** and to the linkage **150** to change the downforce on the row unit **118**), a pneumatic actuator (e.g., including an extendable rod coupled to the main frame **14** and linkage **150** to move the row unit frame **130** downward and change the downforce on the row unit **118**), a motorized actuator, or any other type of actuator that when activated changes a downforce on the row unit **118**.

With continued reference to FIG. **2**, the downforce adjustment system **142** further includes a controller **162** and at least one moisture sensor **166**. The controller **162** includes a processor, and is coupled to and communicates with both the actuator **146** (e.g., the pressure source **158** of the actuator **146**) and the moisture sensor **166**. In some constructions, the controller **162** is mounted to one of the row units **118** itself, on the main frame **14**, or on the operator's cab **12**. In some constructions, the controller **162** is disposed remotely from the row unit **118**, the main frame **14**, and the operator's cab **12**. In the illustrated construction, the controller **162** communicates wirelessly with both the actuator **146** and the moisture sensor **166**. In other constructions, one or more wired connections are used.

The moisture sensor **166** detects levels of moisture in the soil **20** beneath the seeding machine **10** as the seeding machine **10** moves over the soil **20**. In some constructions, the moisture sensor **166** detects a level of moisture at a specified depth **170** below a top surface **174** of the soil **20** (e.g., at a predetermined, or default, planting depth). In the illustrated construction, the moisture sensor **166** is mounted to the seed firmer device **141**. In other constructions, the moisture sensor **166** is coupled to another area of the seeding machine **10**, such as to the main frame **14**, to the towing tractor, or to another area on the row unit **118**. In some constructions, the moisture sensor **166** is positioned to detect moisture of approaching soil ahead of the furrow opener **134** (i.e., to the right of the furrow opener **134** in FIG. **2**, along the direction of movement **145**). In some constructions, the

seeding machine **10** includes a plurality of row units **118**, each having its own moisture sensor or sensors **166**. The moisture sensors **166** may be any of a variety of types of sensors, including capacitive sensors in contact with the soil **20**, infrared sensors, or radar sensors.

With continued reference to FIG. **2**, in the illustrated construction the moisture sensor **166** sends a signal (e.g., a continuous signal or signals) corresponding to the moisture level of the soil **20** to the controller **162**. The controller **162** is programmed to receive the signal or signals from the moisture sensor **166** and to determine whether or not to actuate the actuator **146** and change the downforce (i.e., increase the downforce or decrease the downforce) on the row unit **118**.

It is desirable for seeds to be planted at depths and in moisture conditions that result in optimal growth and emergence. In the illustrated construction, if the moisture sensor **166** detects high levels of moisture in the soil **20** (e.g., moisture levels above a predetermined threshold), the controller **162** sends a signal to the actuator **146** to decrease the downforce on the row unit **118** and allowing the linkage **150** and the row unit overall **118** to rise. Conversely, if the moisture sensor **166** detects low levels of moisture in the soil **20** (e.g., moisture levels below a predetermined threshold), the controller **162** sends a signal to the actuator **146** to increase the downforce on the row unit **118** and causing the linkage **150** and the row unit overall **118** to lower. In some constructions, the amount of change of the downforce is proportional to the amount of detected moisture. For example, in some constructions the higher the detected moisture content in the soil **20**, the smaller the downforce applied by the downforce adjustment system **142**. Conversely, the lower the detected moisture content of the soil **20**, the higher the downforce applied by the downforce adjustment system **142**.

Other constructions include different correlations between the downforce and the measured moisture level. However, at least with respect to corn, it has been found that in moist soil conditions corn generally emerges more rapidly with a lower downforce, and in drier soil conditions corn generally emerges more rapidly with a higher downforce. In some constructions, a farmer may have three or more different types of fields, each having its own separate soil moisture level, or a single field with varying soil moisture levels. Thus, the system and controls described above advantageously provide a farmer with options for causing faster emergence and growth in each type of soil than would otherwise be expected.

With continued reference to FIG. **2**, in some constructions the moisture sensor **166**, the controller **162**, and the actuator **146** form a closed loop, such that the moisture sensor **166** continuously monitors moisture levels in the soil **20** and sends signals to the controller **162**, and the actuator **146** continuously adjusts a downforce on the row unit **118** based on signals from the controller **162**. This ensures that the planting depths for each seed planted by the row unit **118** are continuously adjusted as needed to ensure desired plant emergence.

For example, in some constructions the moisture sensor **166** detects a level of moisture in the soil **20**. If the controller **162** determines that the moisture level is above a predetermined threshold the downforce is decreased. After decreasing the downforce, if the moisture sensor **166** then detects that the moisture level has fallen below the predetermined threshold, the downforce is then increased.

Conversely, in some constructions if the controller **162** determines that the moisture level is below a predetermined

5

threshold the downforce is increased. After increasing the downforce, if the moisture sensor 166 then detects that the moisture level has risen above the predetermined threshold, the downforce is then decreased.

Other constructions include an open loop system, in which the controller 162 provides a signal or signals to a user (e.g., via a user interface on the operator's cab 12) from the moisture sensor 166, and the user must determine whether or not to manually activate the actuator 146 to change the downforce on the row unit 118.

In some constructions, the seeding machine 10 includes a plurality of row units 118. Each of the row units 118 includes its own associated actuator 146. The actuators 146 are coupled to a single controller 162, such that the single controller 162 controls each of the associated actuators 146 individually.

In some constructions, the moisture sensor 166 is one of a plurality of moisture sensors 166 that are each coupled to a single controller 162. Each moisture sensor 166 is associated with a different row unit 118.

In some constructions, each of the row units 118 includes its own associated controller 162, its own associated moisture sensor 166, and its own associated actuator 146, such that each controller 162 only communicates with the moisture sensor 166 and the actuator 146 associated with a particular row unit 118.

In some constructions, only a single moisture sensor 166 is used for the entire seeding machine 10, and the downforce for all of the row units 118 is identical for each row unit 118, based on the moisture level detected by the single moisture sensor.

In some constructions, one moisture sensor 166 is used for a section on the machine 10 and the downforce for all the row units 118 on each section is identical based on the moisture level detected by the single moisture sensor for that section.

Various features and advantages of the disclosure are set forth in the following claims.

What is claimed is:

1. A seeding machine comprising:

a main frame;

a row unit coupled to the main frame, the row unit having a row unit frame, a gauge wheel coupled to the row unit frame, and a furrow opener coupled to the row unit frame; and

a downforce adjustment system for adjusting an amount of downforce applied to the row unit, the downforce adjustment system including a moisture sensor configured to detect a moisture level of soil, a controller configured to receive a signal from the moisture sensor corresponding to the detected moisture level, and an actuator configured to change the amount of downforce applied to the row unit based on the signal received by the controller,

wherein the row unit is one of a plurality of row units coupled to the main frame, and wherein each of the row units includes its own associated controller, its own associated moisture sensor, and its own associated actuator, such that each controller only communicates with the moisture sensor and the actuator associated of a single row unit.

2. The seeding machine of claim 1, wherein the moisture sensor is coupled to the row unit.

3. The seeding machine of claim 2, further comprising a seed firmer device coupled to the row unit frame, wherein the moisture sensor is coupled to the seed firmer device.

6

4. The seeding machine of claim 1, wherein the seeding machine has a direction of travel, and wherein the moisture sensor is positioned to detect the moisture level of approaching soil ahead of the furrow opener along the direction of travel.

5. The seeding machine of claim 1, wherein the moisture sensor is selected from a group consisting of a capacitive sensor, an infrared sensor, and a radar sensor.

6. The seeding machine of claim 1, wherein the moisture sensor detects a moisture level at a predetermined depth within soil.

7. The seeding machine of claim 1, wherein the actuator is a pneumatic or hydraulic actuator.

8. The seeding machine of claim 7, wherein the linkage is pivotally coupled to the main frame.

9. The seeding machine of claim 1, wherein the controller is mounted to the row unit.

10. The seeding machine of claim 1, wherein the controller is configured to increase the downforce on the row unit if the detected moisture level is below a predetermined threshold.

11. The seeding machine of claim 1, wherein the controller is configured to decrease the downforce on the row unit if the detected moisture level is above a predetermined threshold.

12. The seeding machine of claim 1, wherein the moisture sensor, the controller, and the actuator form a closed loop control, such that the moisture sensor continuously monitors moisture levels in the soil and send signals to the controller, and the actuator continuously adjusts a downforce on the row unit based on signals received from the controller.

13. The seeding machine of claim 1, wherein the row unit is one of a plurality of row units coupled to the main frame, wherein each row unit includes an associated actuator, and wherein the actuators are coupled to a single controller, such that the single controller controls each of the associated actuators individually.

14. The seeding machine of claim 13, wherein the moisture sensor is one of a plurality of moisture sensors that are each coupled to the single controller, and wherein each moisture sensor is associated with a different row unit.

15. A seeding machine comprising:

a main frame;

a row unit coupled to the main frame, the row unit having a row unit frame, a gauge wheel coupled to the row unit frame, and a furrow opener coupled to the row unit frame; and

a downforce adjustment system for adjusting an amount of downforce applied to the row unit, the downforce adjustment system including a moisture sensor configured to detect a moisture level of soil, a controller configured to receive a signal from the moisture sensor corresponding to the detected moisture level, and an actuator configured to change the amount of downforce applied to the row unit based on the signal received by the controller,

wherein the row unit is one of a plurality of row units coupled to the main frame, wherein the moisture sensor is a single moisture sensor, and wherein the downforce applied to each row unit is identical based on the moisture level detected by the single moisture sensor.

16. A seeding machine comprising:

a main frame;

a row unit coupled to the main frame, the row unit having a row unit frame; and

a downforce adjustment system coupled to the row unit for adjusting an amount of downforce applied to the row unit, the downforce adjustment system including: a moisture sensor coupled to the row unit and configured to detect a moisture level of one or more layers of soil, the moisture sensor selected from a group consisting of a capacitive sensor, an infrared sensor, and a radar sensor; a controller configured to receive a signal from the moisture sensor corresponding to the detected moisture level; an actuator configured to change the amount of downforce applied to the row unit based on the signal received by the controller; and a linkage coupled to the actuator, the row unit frame, and the main frame, wherein the linkage is pivotally coupled to the main frame, wherein the row unit is one of a plurality of row units coupled to the main frame, and wherein each of the row units includes its own associated controller, its own associated moisture sensor, and its own associated actuator, such that each controller only communicates with the moisture sensor and the actuator associated of a single row unit.

17. The seeding machine of claim **16**, wherein the controller is configured to increase the downforce on the row unit if the detected moisture level is below a predetermined threshold, and wherein the controller is configured to decrease the downforce on the row unit if the detected moisture level is above a predetermined threshold.

* * * * *