

US009666090B2

(12) **United States Patent**
Kahle et al.

(10) **Patent No.:** **US 9,666,090 B2**
(45) **Date of Patent:** **May 30, 2017**

(54) **REFERENCE BASED POSITIONING OF HANDHELD TOOLS**

(71) Applicant: **Trimble Navigation Limited**, Sunnyvale, CA (US)

(72) Inventors: **Kent Kahle**, Hayward, CA (US); **Pat Bohle**, Boulder, CO (US); **Markus Messmer**, Wasserburg (DE); **Oliver Glockner**, Feldkirch (AT); **Angela Beckenbauer**, St. Gallen (CH); **Till Cramer**, Jenins (CH); **Andreas Winter**, Feldkirch (AT); **Reinhard Waibel**, Berneck (CH)

(73) Assignee: **Trimble Inc.**, Sunnyvale, CA (US)

(*) Notice: Subject to any disclaimer, the term of this patent is extended or adjusted under 35 U.S.C. 154(b) by 294 days.

(21) Appl. No.: **13/689,529**

(22) Filed: **Nov. 29, 2012**

(65) **Prior Publication Data**
US 2013/0137079 A1 May 30, 2013

Related U.S. Application Data
(60) Provisional application No. 61/564,560, filed on Nov. 29, 2011.

(51) **Int. Cl.**
G09B 9/00 (2006.01)
G01C 15/00 (2006.01)
G01S 19/14 (2010.01)
G01S 19/45 (2010.01)

(52) **U.S. Cl.**
CPC **G09B 9/00** (2013.01); **G01C 15/00** (2013.01); **G01S 19/14** (2013.01); **G01S 19/45** (2013.01)

(58) **Field of Classification Search**
CPC G09B 23/28; G09B 23/285; G09B 23/30; G09B 9/00; G01C 15/00; G01S 19/14; G01S 19/45
USPC 434/11-72, 262-275, 365
See application file for complete search history.

(56) **References Cited**
U.S. PATENT DOCUMENTS
5,903,462 A 5/1999 Wagner et al.
5,918,219 A 6/1999 Isherwood
6,433,689 B1 8/2002 Hovind et al.
6,435,286 B1 8/2002 Stump et al.
6,484,818 B2 11/2002 Alft et al.
6,544,041 B1* 4/2003 Damadian 434/262
6,857,879 B2 2/2005 Sawada et al.
(Continued)

FOREIGN PATENT DOCUMENTS
DE 202006014606 U1 1/2007
DE 202006016830 U1 1/2007
(Continued)

OTHER PUBLICATIONS
“International Search Report PCT/2012/066906”, 22 Pages, Sep. 12, 2013.
(Continued)

Primary Examiner — Timothy A Musselman
(74) *Attorney, Agent, or Firm* — Kilpatrick Townsend & Stockton LLP

(57) **ABSTRACT**
A method for positioning a handheld tool is disclosed. In one embodiment, information is received at a handheld tool for positioning a working end of the handheld tool at a desired position. Information is also received at the handheld tool for aligning the handheld tools at the desired position.

19 Claims, 9 Drawing Sheets

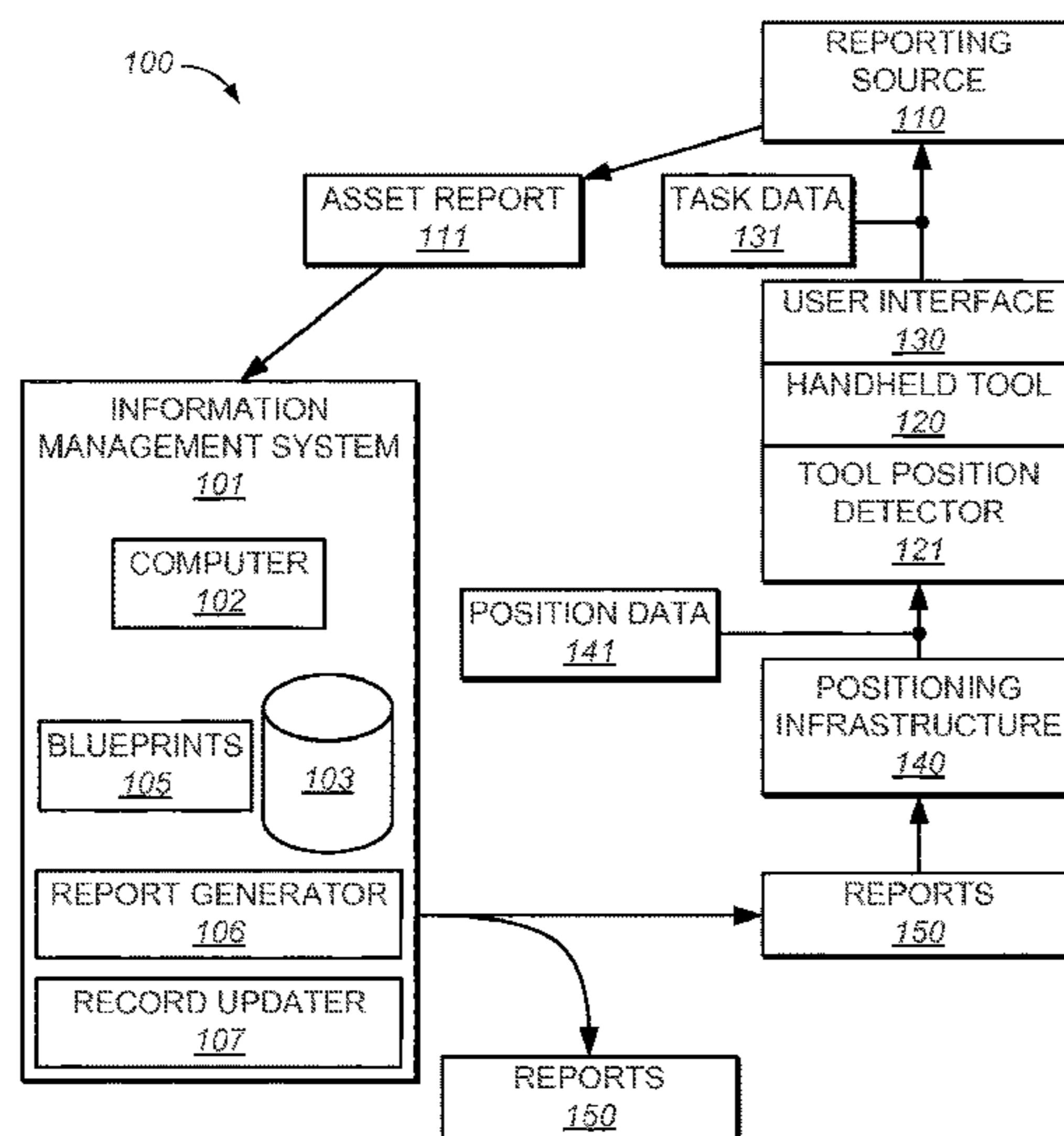

(56)

References Cited

U.S. PATENT DOCUMENTS

6,981,311	B2	1/2006	Seith et al.	
7,245,999	B2	7/2007	Dietsch et al.	
7,301,536	B2	11/2007	Ellenby et al.	
7,319,395	B2	1/2008	Puzio et al.	
7,613,590	B2	11/2009	Brown	
7,681,192	B2	3/2010	Dietsch et al.	
7,788,317	B2	8/2010	Chraiet et al.	
8,004,664	B2	8/2011	Etter et al.	
8,041,650	B2	10/2011	Gaffey et al.	
8,316,741	B2	11/2012	Wallgren	
8,362,973	B2	1/2013	Cernasov et al.	
8,532,342	B2	9/2013	Nielsen et al.	
8,619,022	B1	12/2013	Hart	
8,620,587	B2	12/2013	Nielsen et al.	
8,626,384	B2	1/2014	Newman et al.	
8,647,124	B2	2/2014	Bardsley et al.	
8,657,482	B2	2/2014	Malackowski et al.	
8,749,239	B2	6/2014	Nielsen et al.	
8,974,467	B2*	3/2015	Stone	A61B 17/175 606/102
2004/0172800	A1	9/2004	Seith et al.	
2004/0210370	A1	10/2004	Gudat et al.	
2004/0248586	A1	12/2004	Patel et al.	
2005/0110639	A1	5/2005	Puzio et al.	
2006/0155582	A1	7/2006	Brown	
2006/0173600	A1	8/2006	Dietsch et al.	
2006/0193262	A1	8/2006	McSheffrey et al.	
2007/0010925	A1	1/2007	Yokoyama et al.	
2007/0011285	A1	1/2007	Chraiet et al.	
2007/0027732	A1	2/2007	Hudgens	
2007/0210929	A1	9/2007	Sabata et al.	
2008/0125942	A1*	5/2008	Tucker	A01B 69/008 701/50
2008/0133128	A1	6/2008	Koch	

2009/0202975	A1*	8/2009	Bolick	G09B 25/02 434/401
2009/0204466	A1	8/2009	Nielsen et al.	
2010/0010882	A1	1/2010	Nielsen et al.	
2010/0061181	A1	3/2010	Malackowski et al.	
2010/0167250	A1*	7/2010	Ryan et al.	434/267
2010/0173582	A1	7/2010	Han	
2010/0174656	A1	7/2010	Nolan	
2010/0188407	A1*	7/2010	Nielsen	G06Q 10/06 345/440
2010/0275747	A1	11/2010	Wallgren	
2010/0295754	A1	11/2010	Cernasov et al.	
2011/0249122	A1	10/2011	Tricoukes et al.	
2012/0015665	A1	1/2012	Farley et al.	
2012/0109455	A1	5/2012	Newman et al.	
2012/0270197	A1*	10/2012	Brost et al.	434/267
2013/0109375	A1	5/2013	Zeiler et al.	
2013/0137079	A1	5/2013	Kahle et al.	
2013/0137468	A1	5/2013	Kahle et al.	
2013/0138465	A1	5/2013	Kahle et al.	
2013/0138466	A1	5/2013	Kahle et al.	
2013/0138606	A1	5/2013	Kahle et al.	
2013/0203032	A1*	8/2013	Bardsley et al.	434/268
2014/0365259	A1	12/2014	Delplace et al.	

FOREIGN PATENT DOCUMENTS

DE	202011004847	U1	6/2011
JP	2010-039907		2/2010
KR	10-2009-0015354		2/2009

OTHER PUBLICATIONS

"12853817.0 Extended Supplementary Search Report", May 29, 2015, pp. 1-8.

* cited by examiner

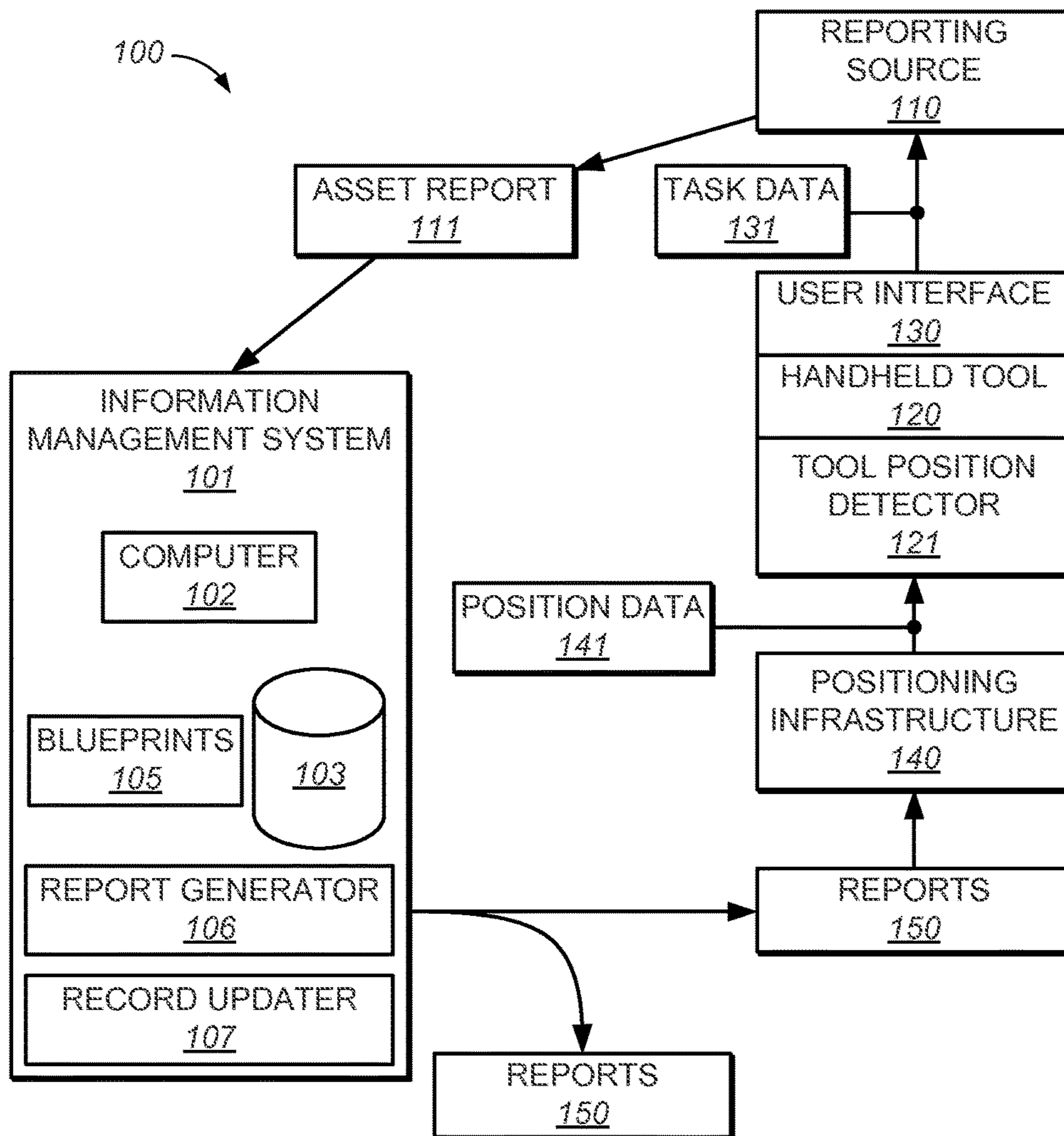

FIG. 1

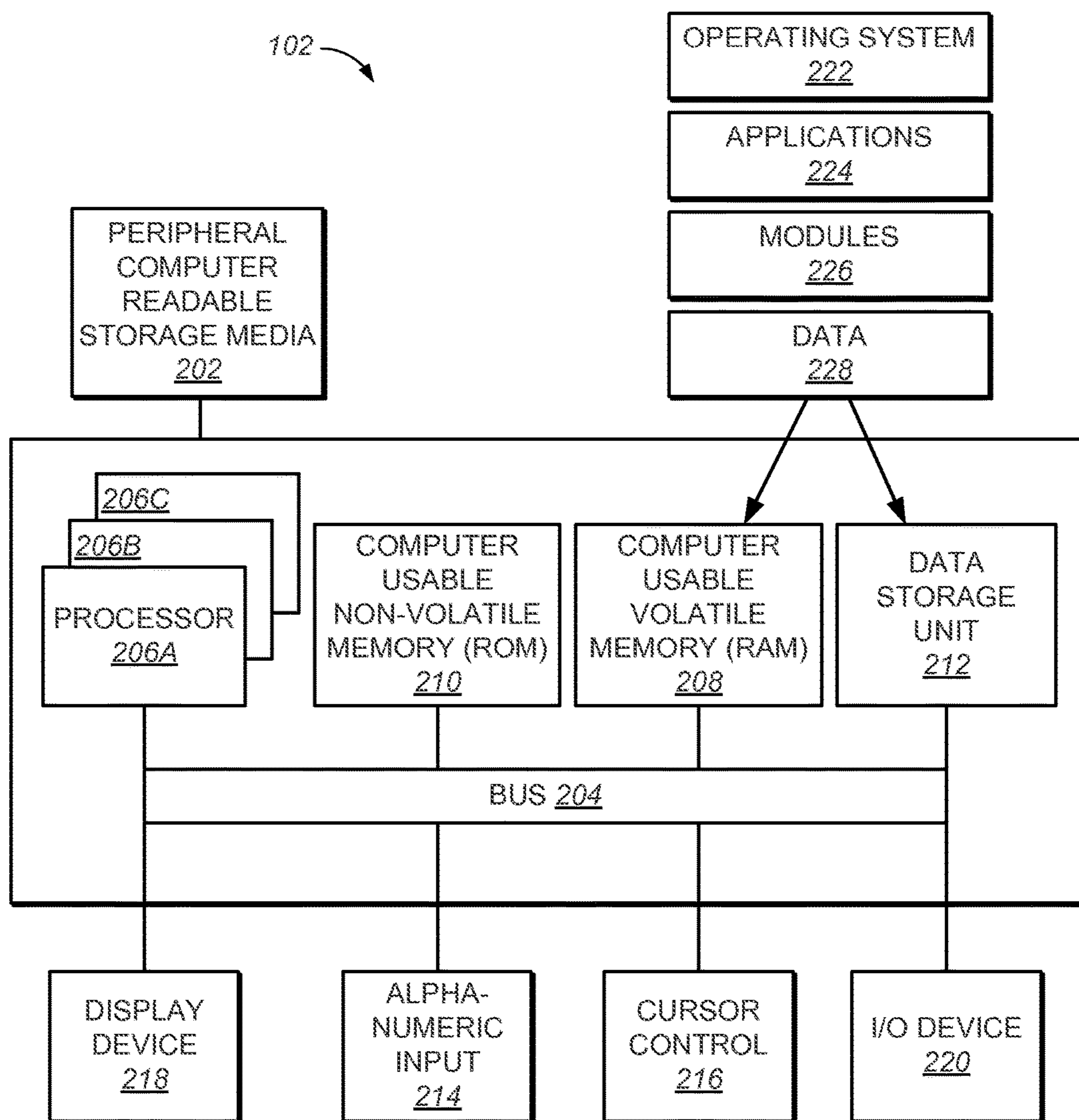

FIG. 2

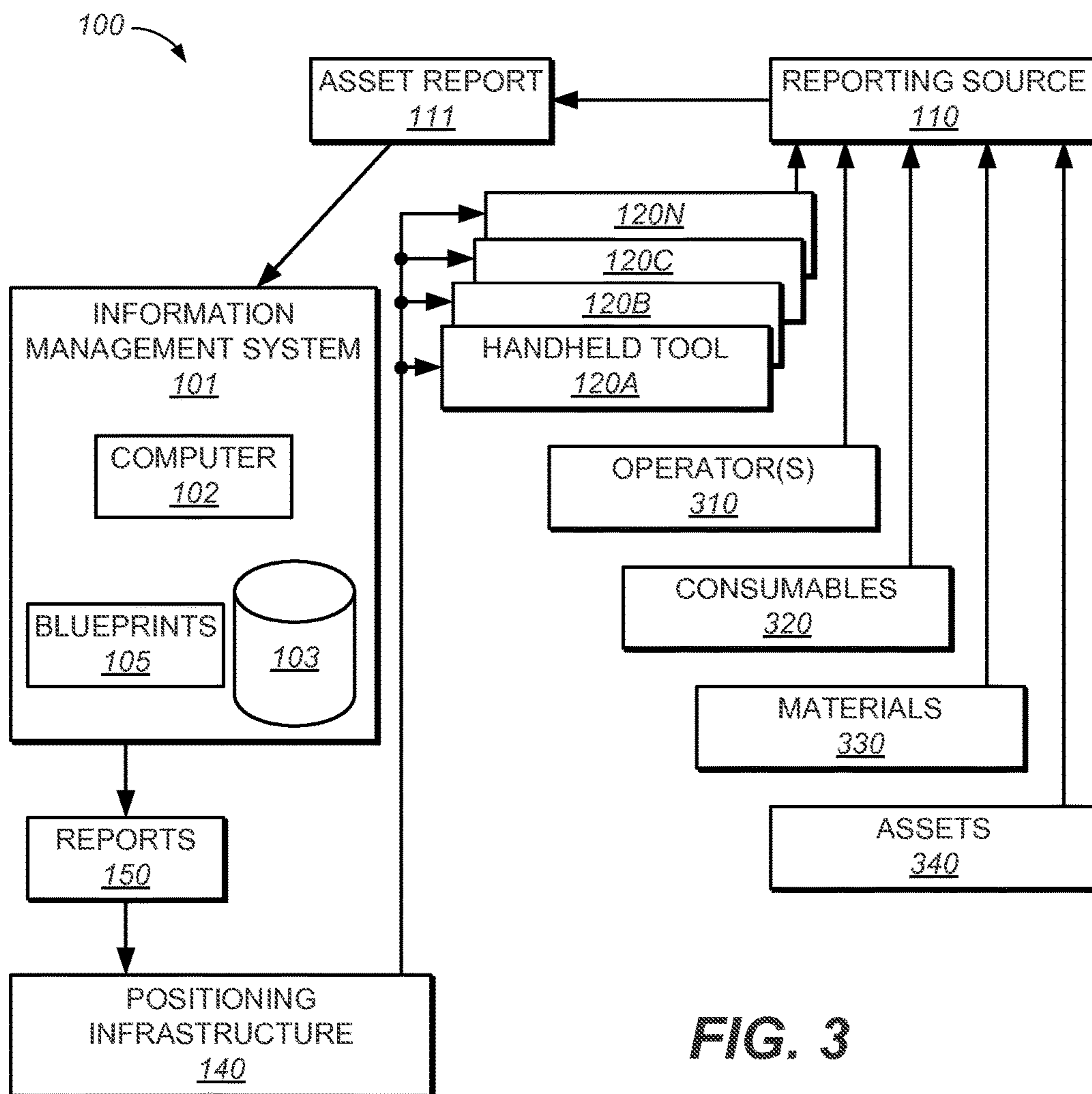

FIG. 3

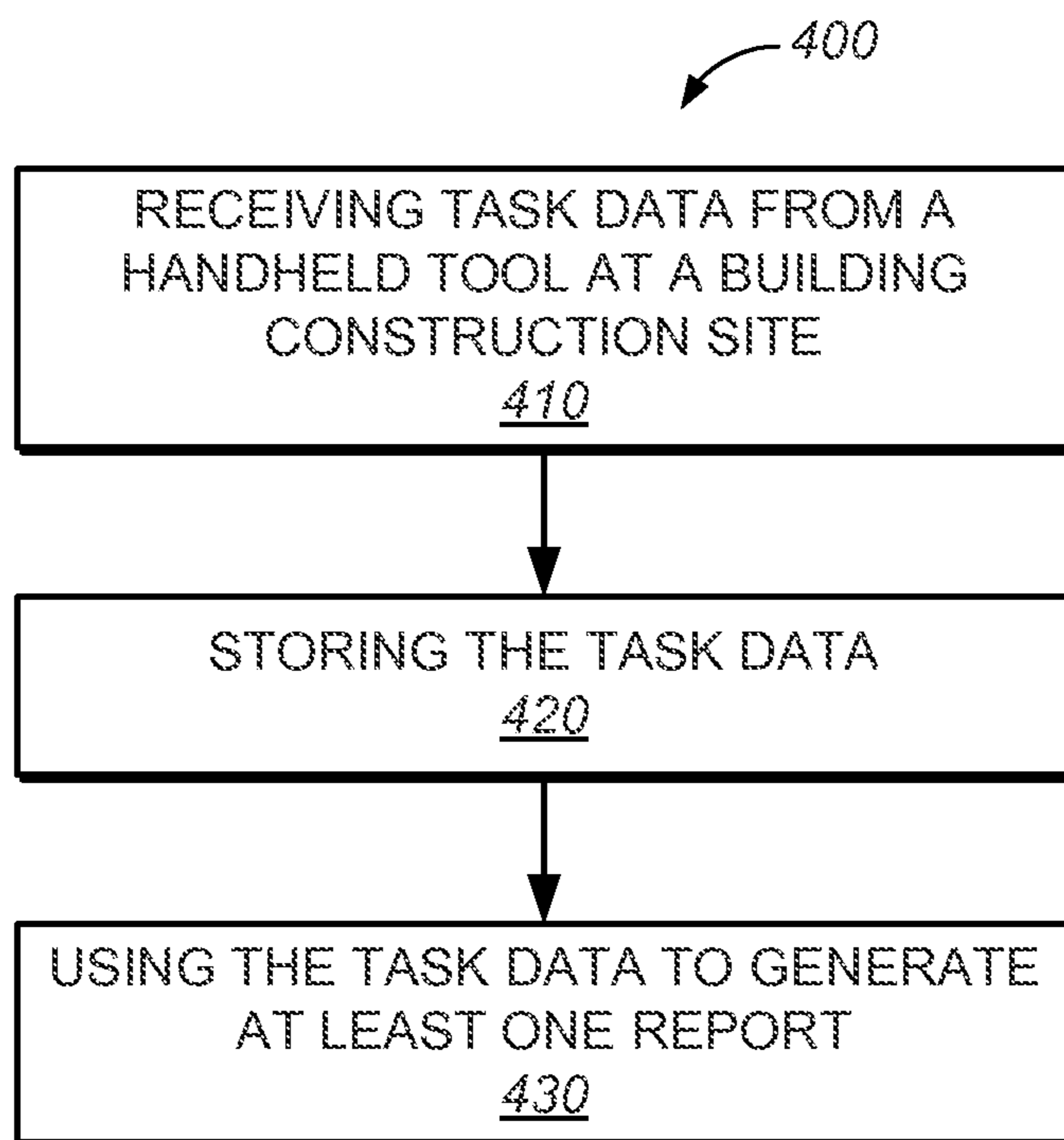

FIG. 4

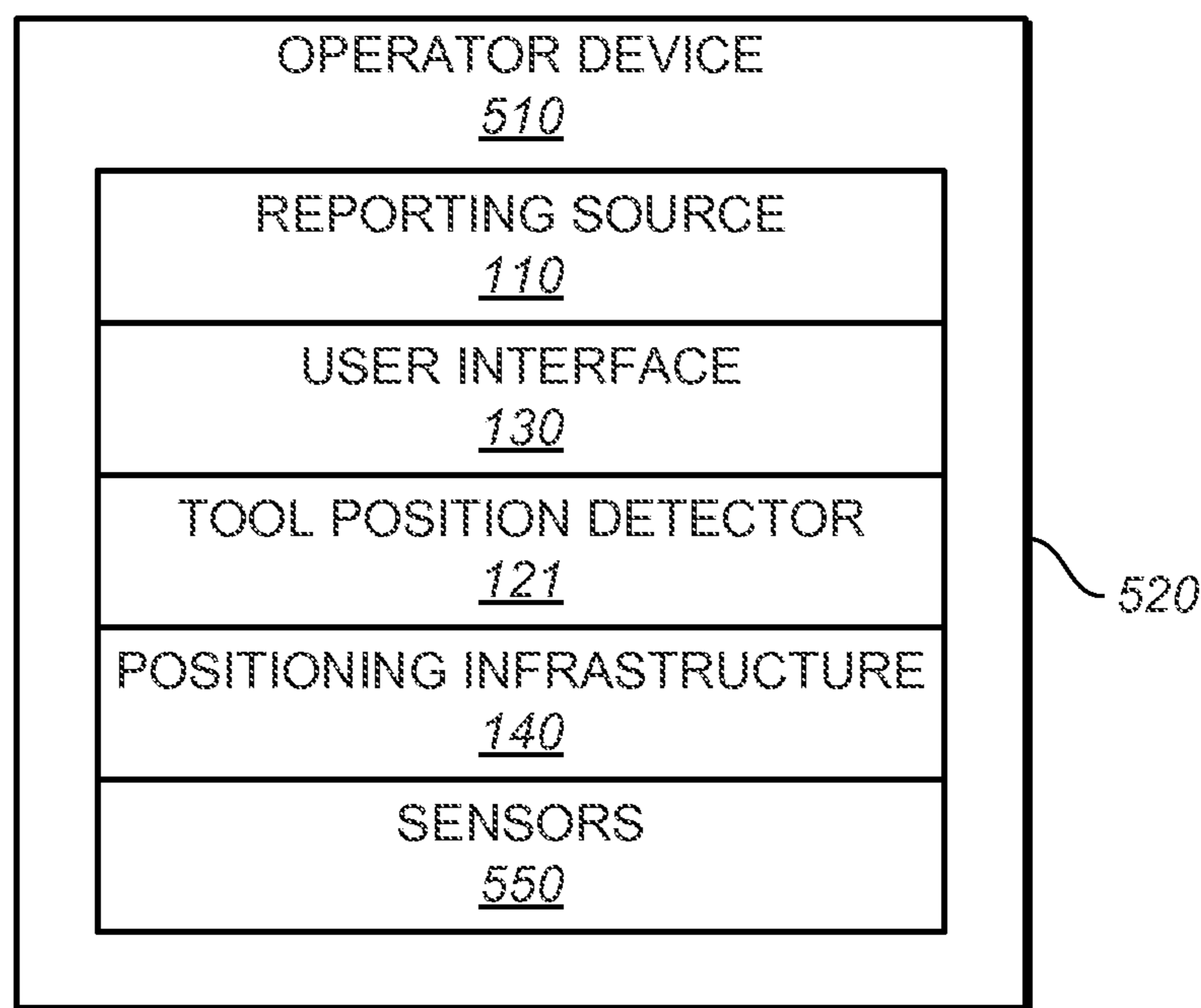

FIG. 5A

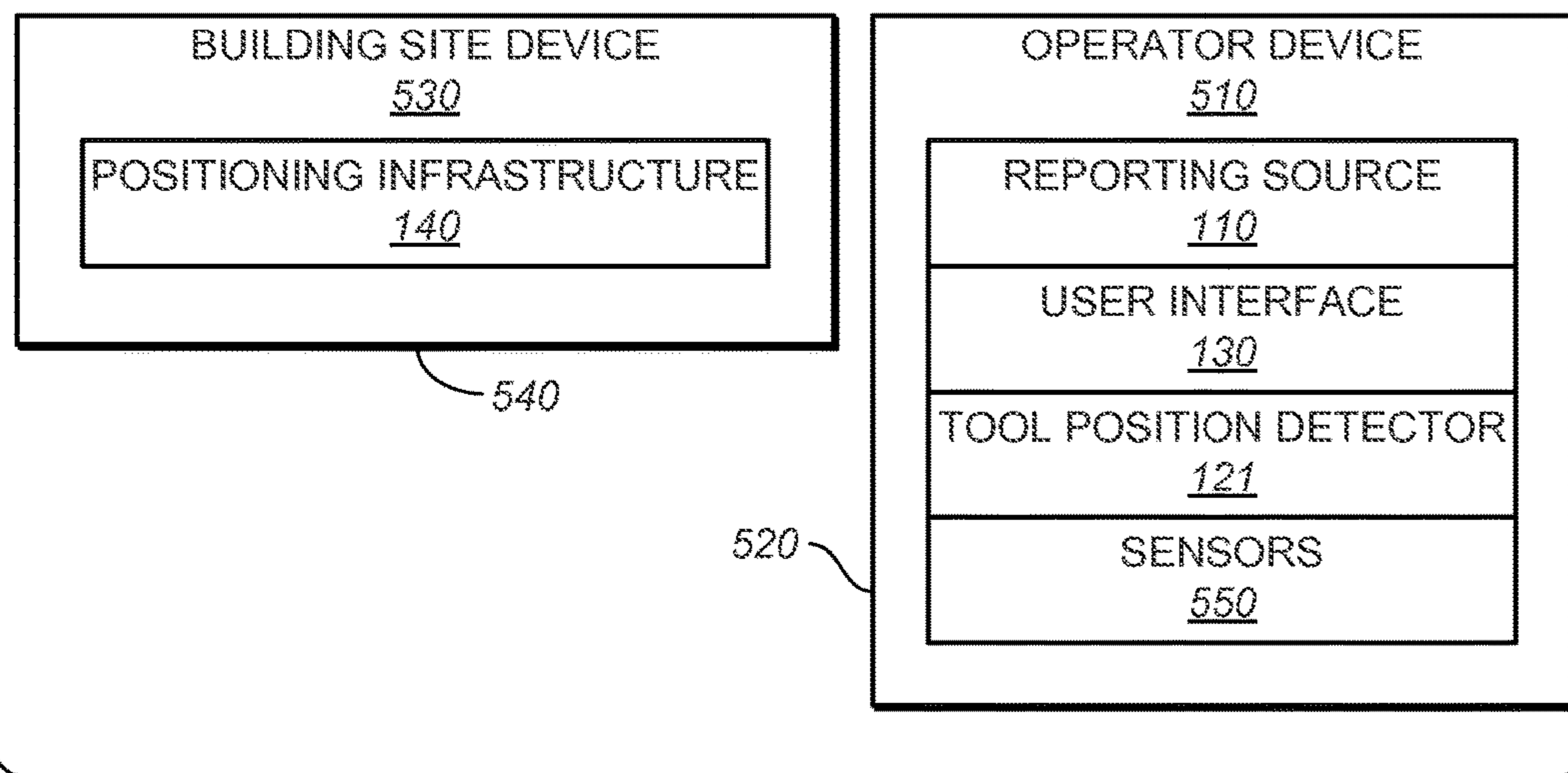

FIG. 5B

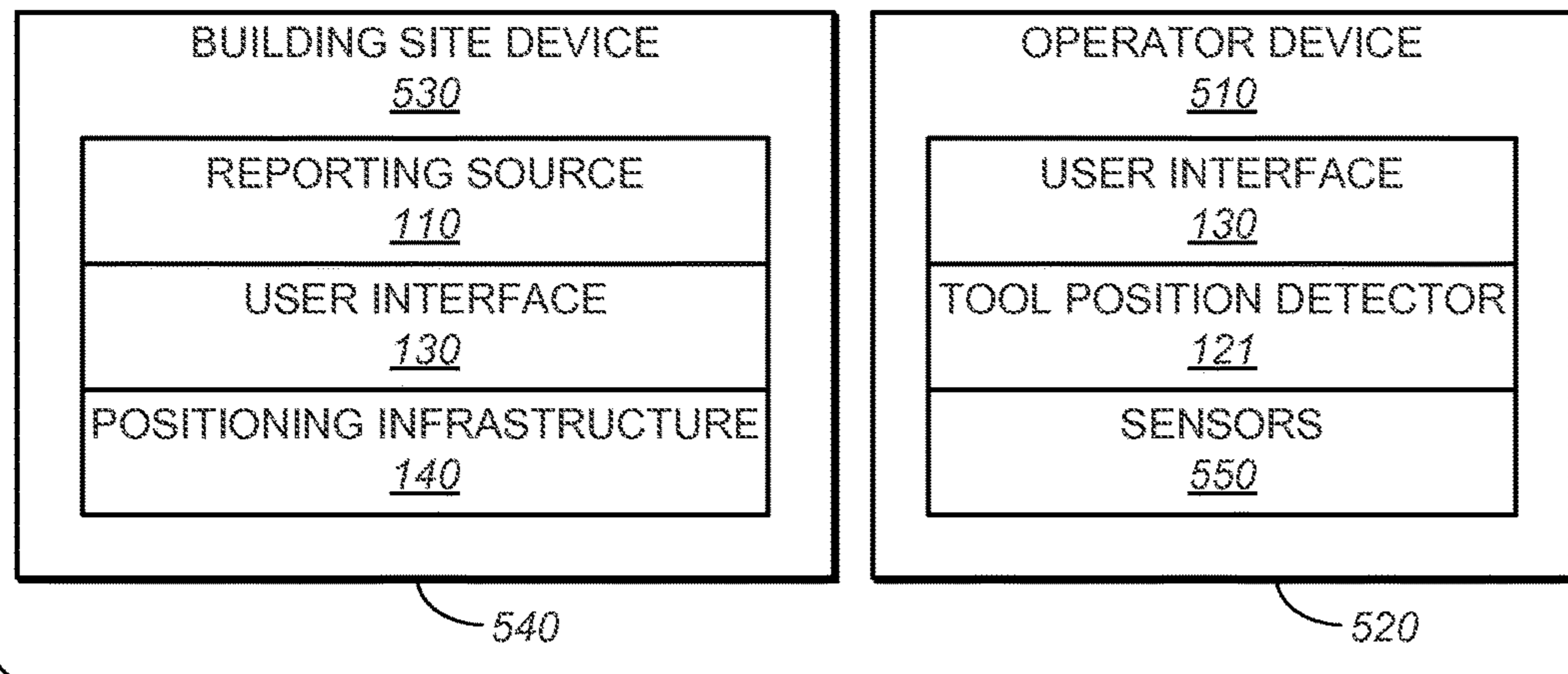

FIG. 5C

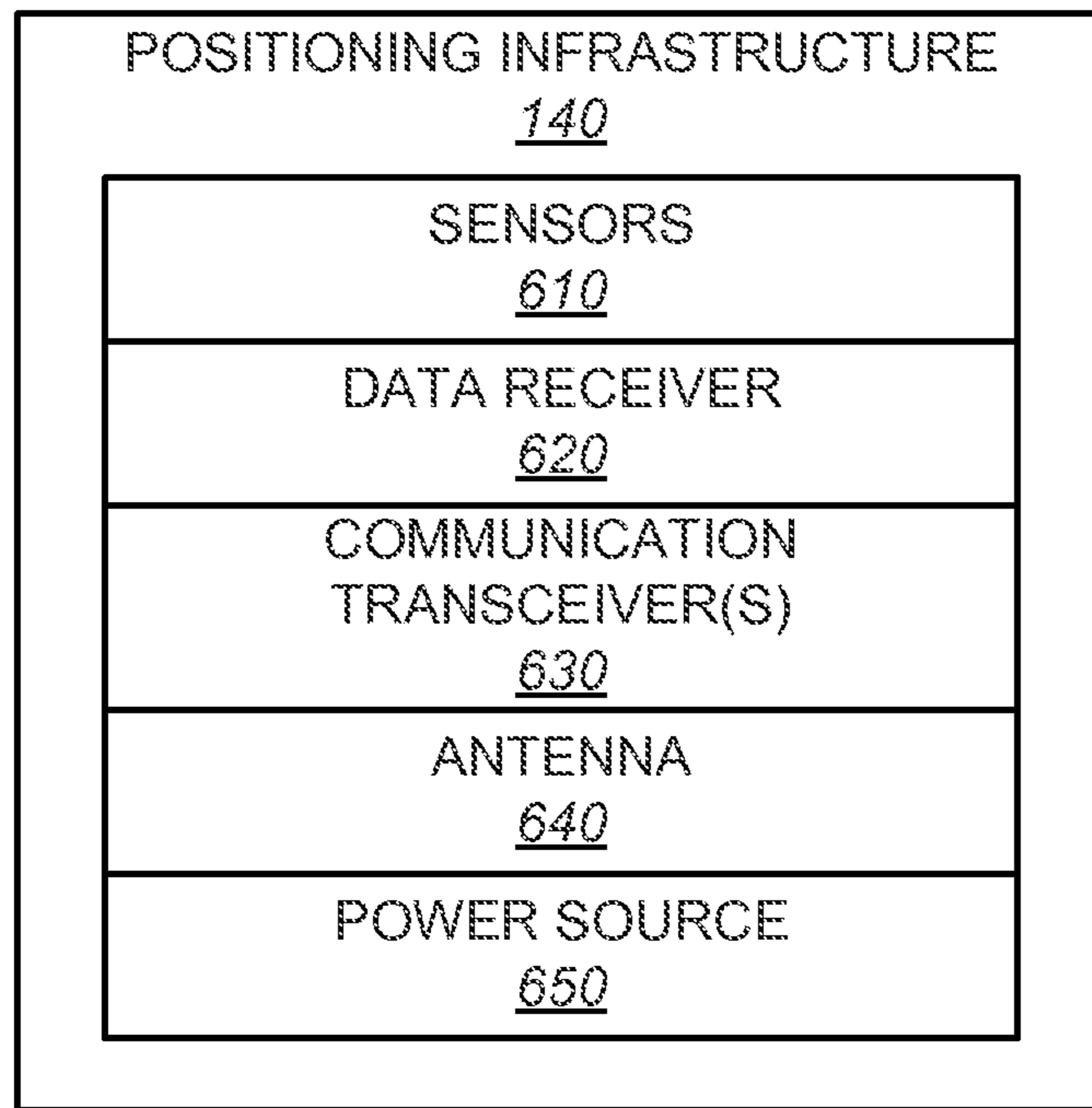

FIG. 6

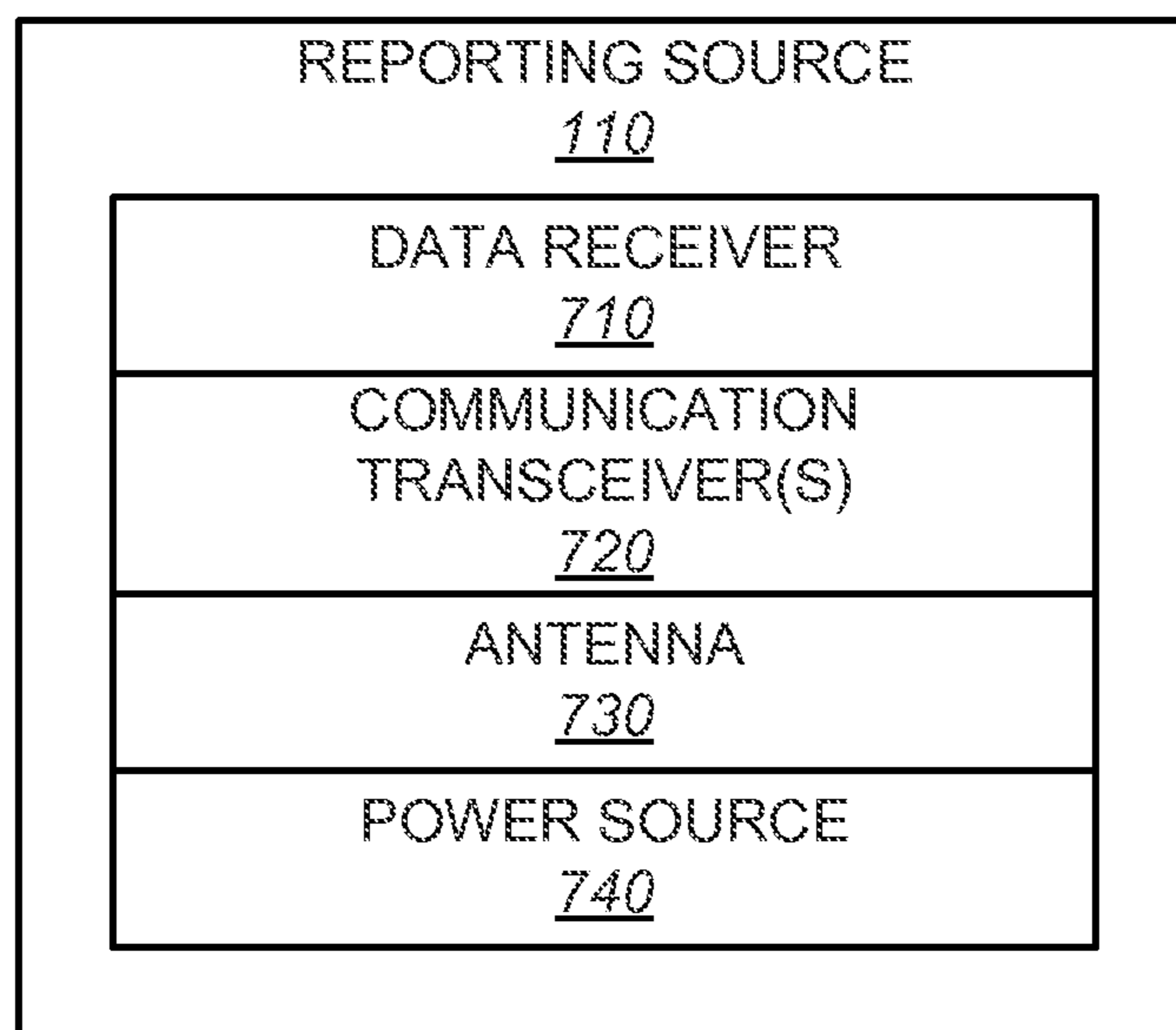

FIG. 7

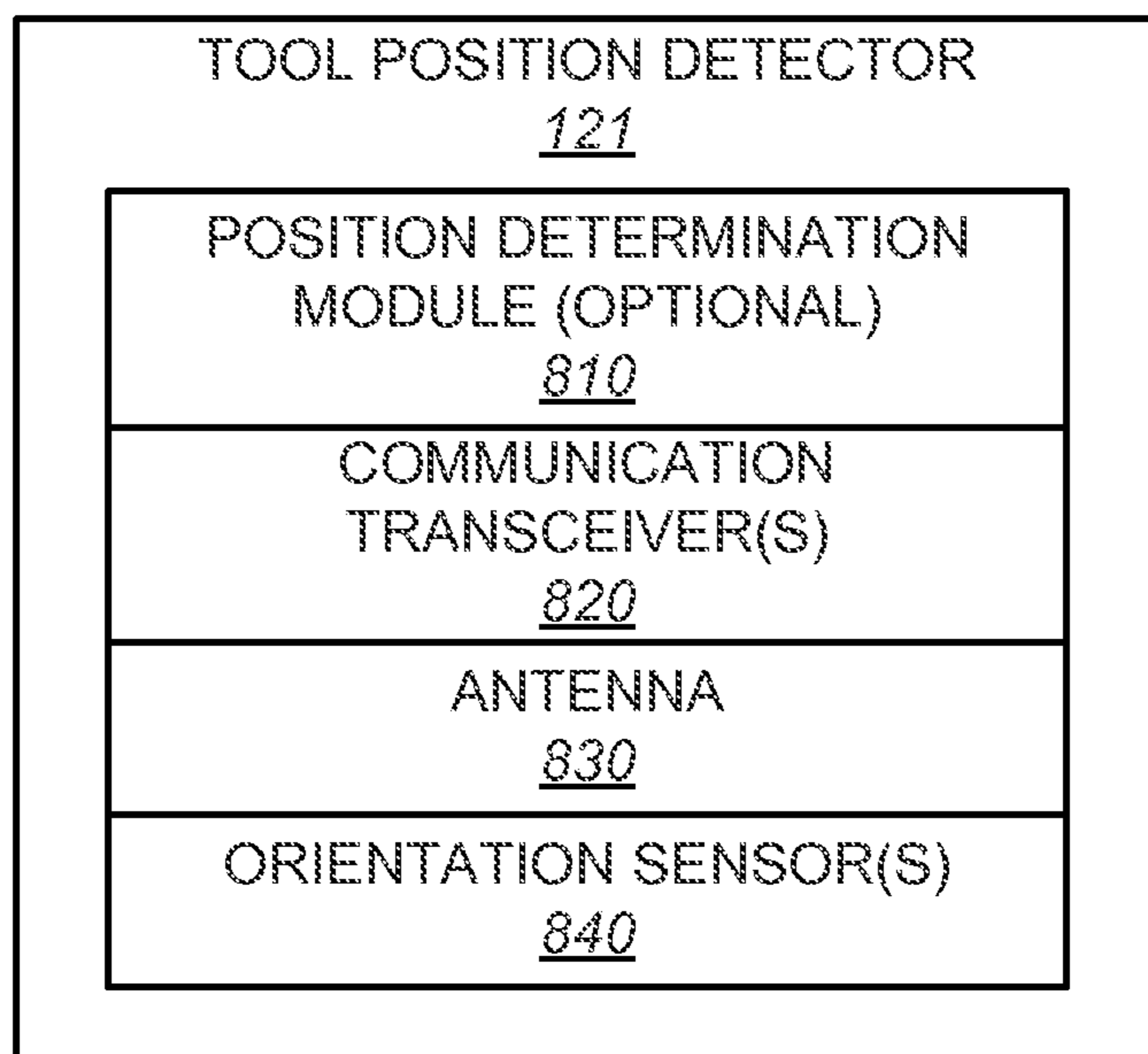

FIG. 8

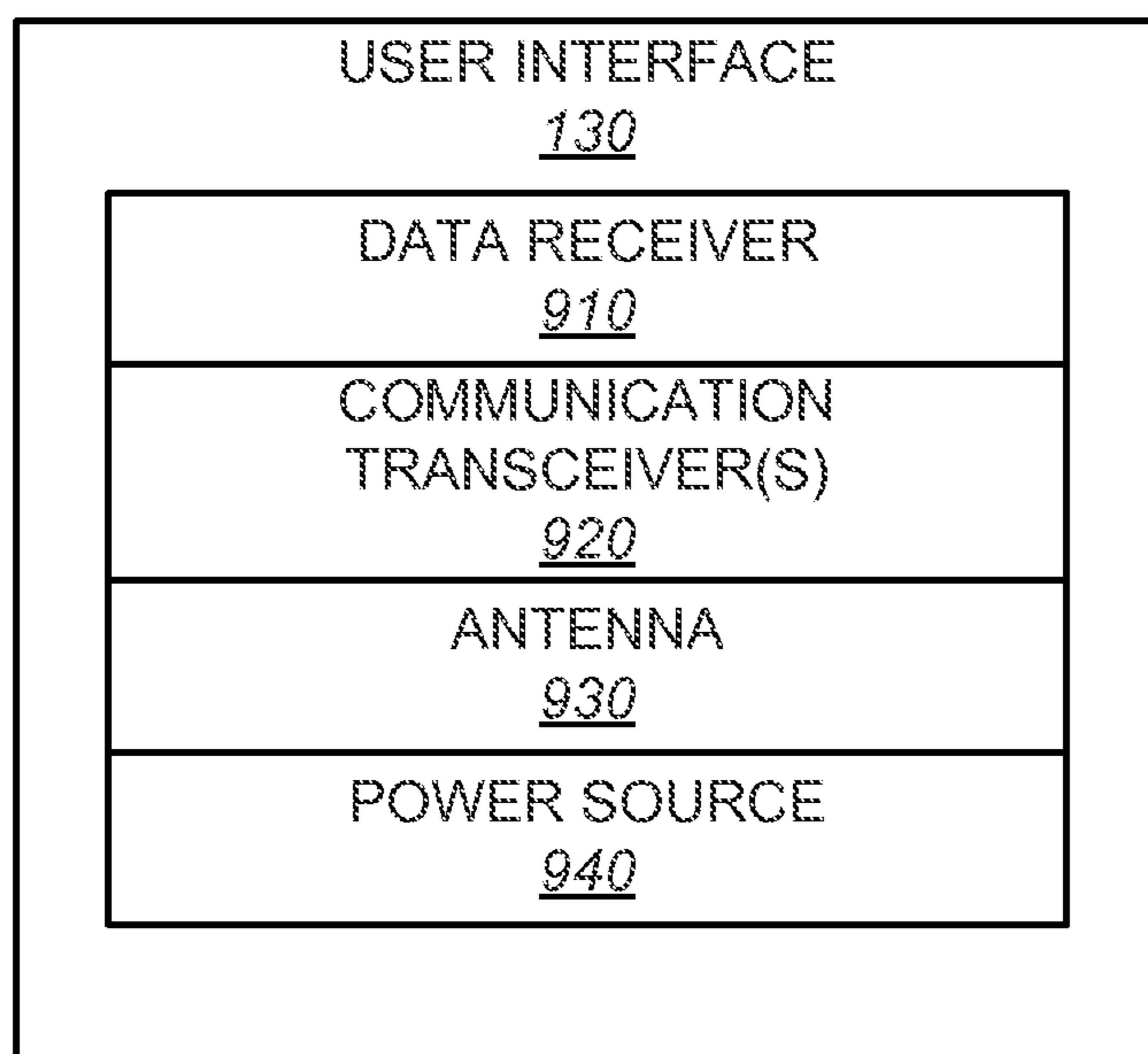

FIG. 9

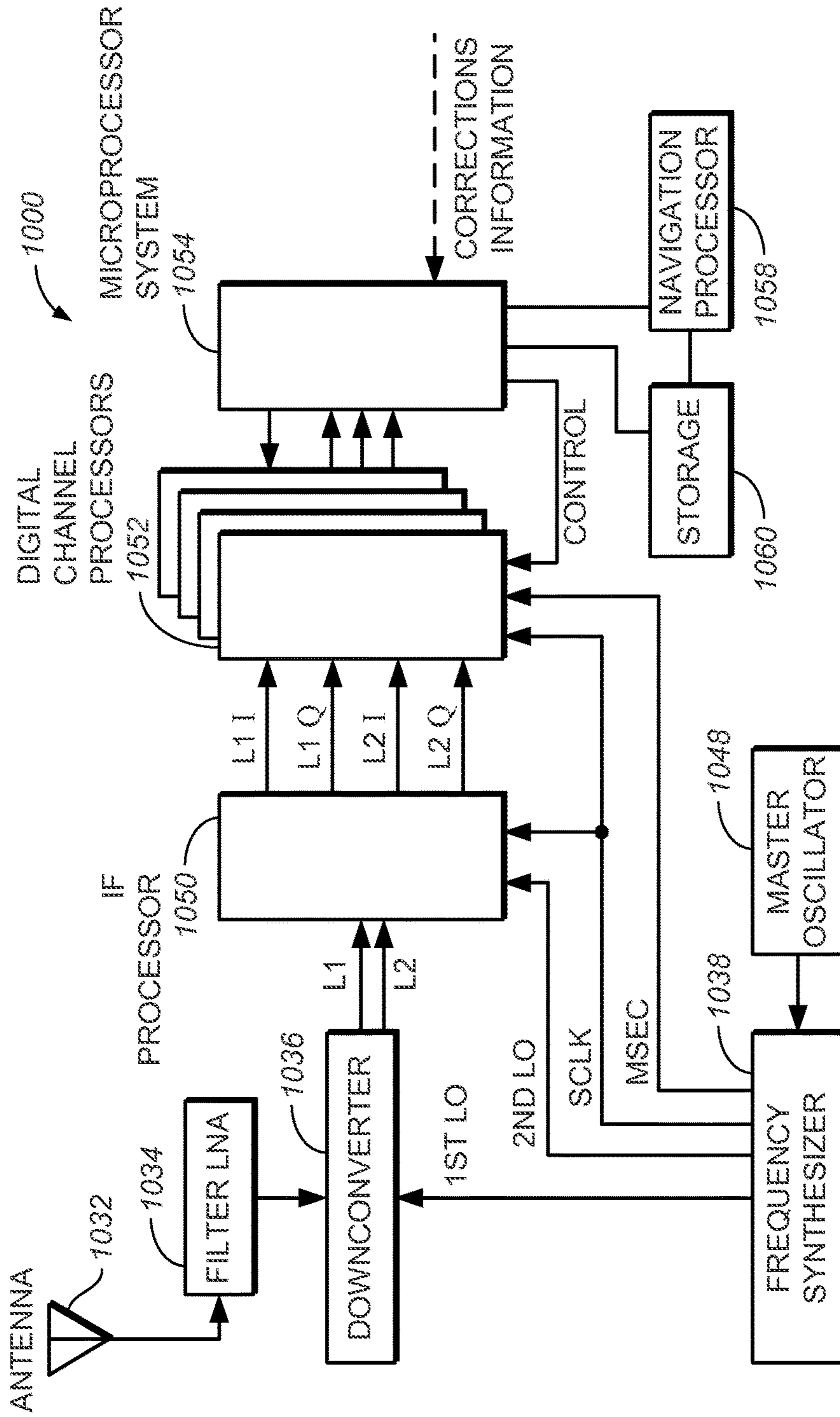

FIG. 10

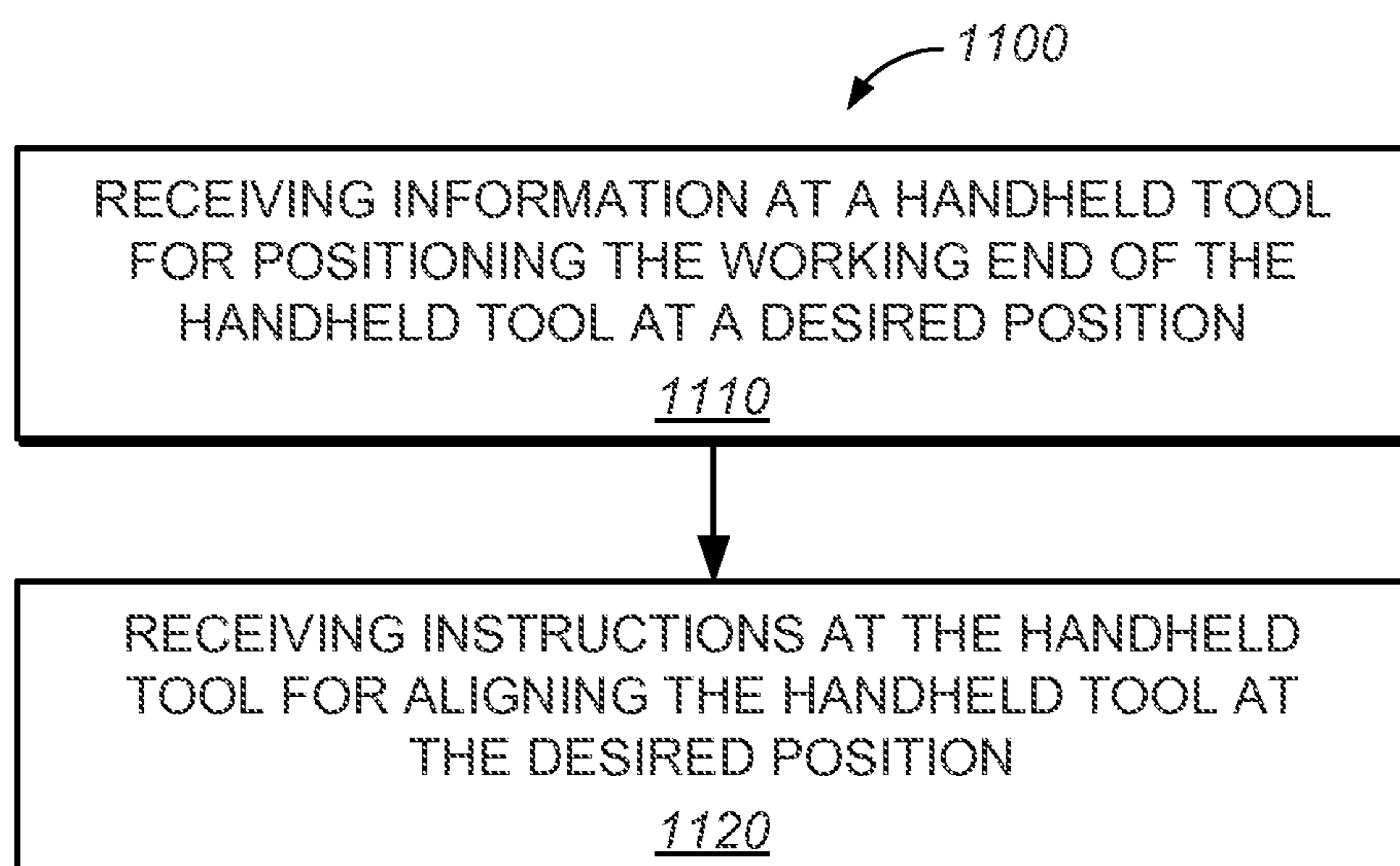

FIG. 11

REFERENCE BASED POSITIONING OF HANDHELD TOOLS

CROSS-REFERENCE TO RELATED APPLICATIONS

This application claims priority to U.S. Provisional Application No. 61/564,560, filed Nov. 29, 2011, titled "Reference Based Positioning of Handheld Tools," by Kent Kahle et al., assigned to the assignee of the present application, and hereby incorporated by reference in its entirety.

This Application is related to U.S. patent application Ser. No. 13/689,519 by Kent Kahle et al., filed on Nov. 29, 2012, titled "Managing Information at a Construction Site," assigned to the assignee of the present patent application.

This Application is related to U.S. patent application Ser. No. 13/689,548 by Kent Kahle et al., filed on Nov. 29, 2012, titled "Integration of as Built Data of a Project," assigned to the assignee of the present patent application.

This Application is related to U.S. patent application Ser. No. 13/689,556 by Kent Kahle et al., filed on Nov. 29, 2012, titled "Integrating Position Information into a Handheld Tool," assigned to the assignee of the present patent application.

This Application is related to U.S. patent application Ser. No. 13/689,575 by Kent Kahle et al., filed on Nov. 29, 2012, titled "Application Information for Power Tools," assigned to the assignee of the present patent application.

This Application is related to U.S. patent application Ser. No. 13/689,595 by Kent Kahle et al., filed on Nov. 29, 2012, titled "Automated Hand Tool Task Verification," assigned to the assignee of the present patent application.

BACKGROUND

During the operations involved with erecting a building, or other structure, there are a wide variety of tasks performed every day which utilize positioning information and positioning tools. This includes moving soil, pouring foundations and footers, erecting walls and roofs, and installing interior systems such as HVAC, plumbing, electrical, sprinklers, as well as interior walls and finishing. Typically, these are manually performed operations using tape measures, electronic layout tools (e.g., plumb lasers and digital levels), distance meters, and even survey-type instruments. These tools are used to layout the dimensions of the structures being built. Additionally, these layout tools are often operated by a single user who marks the position of a particular feature while another user installs or builds the feature at the marked position. For example, an operator of an electronic plumb laser marks positions on a wall where holes are to be drilled. Later, another worker actually drills the holes at the indicated positions.

When a project is completed, the final construction drawings are generated which are intended to show where features of a building are actually located. For example, during the course of erecting a building, pipes may have to be re-routed around a structural member. As a result, the actual building is not reflected in the original construction drawings. When this is not shown on the original construction drawings, they are amended on the fly so that they show the features of the building as built. Again, this is often performed manually so that the final construction drawings are an accurate representation of the building as completed.

SUMMARY

A method for positioning a handheld tool is disclosed. In one embodiment, information is received at a handheld tool

for positioning a working end of the handheld tool at a desired position. Information is also received at the handheld tool for aligning the handheld tools at the desired position.

BRIEF DESCRIPTION OF THE DRAWINGS

The accompanying drawings, which are incorporated in and form a part of this application, illustrate embodiments of the subject matter, and together with the description of embodiments, serve to explain the principles of the embodiments of the subject matter. Unless noted, the drawings referred to in this brief description of drawings should be understood as not being drawn to scale.

FIG. 1 shows an information management network in accordance with an embodiment.

FIG. 2 is a block diagram of an example computer system in accordance with an embodiment.

FIG. 3 shows information management network in accordance with an embodiment.

FIG. 4 is a flowchart of a method for managing information at a construction site in accordance with one embodiment.

FIGS. 5A, 5B, and 5C show different configurations of components of information management network in accordance with various embodiments.

FIG. 6 is a block diagram of an example positioning infrastructure in accordance with one embodiment.

FIG. 7 is a block diagram of an example reporting source in accordance with one embodiment.

FIG. 8 is a block diagram of an example tool position detector in accordance with one embodiment.

FIG. 9 is a block diagram of an example user interface in accordance with one embodiment.

FIG. 10, shows an example Global Navigation Satellite System (GNSS) receiver in accordance with one embodiment.

FIG. 11 is a flowchart of a method of positioning handheld tools in accordance with at least one embodiment.

DESCRIPTION OF EMBODIMENTS

Reference will now be made in detail to various embodiments, examples of which are illustrated in the accompanying drawings. While the subject matter will be described in conjunction with these embodiments, it will be understood that they are not intended to limit the subject matter to these embodiments. On the contrary, the subject matter described herein is intended to cover alternatives, modifications and equivalents, which may be included within the spirit and scope as defined by the appended claims. In some embodiments, all or portions of the electronic computing devices, units, and components described herein are implemented in hardware, a combination of hardware and firmware, a combination of hardware and computer-executable instructions, or the like. In one embodiment, the computer-executable instructions are stored in a non-transitory computer-readable storage medium. Furthermore, in the following description, numerous specific details are set forth in order to provide a thorough understanding of the subject matter. However, some embodiments may be practiced without these specific details. In other instances, well-known methods, procedures, objects, and circuits have not been described in detail as not to unnecessarily obscure aspects of the subject matter.

Notation and Nomenclature

Unless specifically stated otherwise as apparent from the following discussions, it is appreciated that throughout the

present Description of Embodiments, discussions utilizing terms such as “receiving,” “detecting,” “determining,” “coupling,” “sending,” “displaying,” “generating,” “projecting,” or the like, often (but not always) refer to the actions and processes of a computer system or similar electronic computing device such as, but not limited to, a display unit, a reporting unit, an information management system, a tool interface, or component thereof. The electronic computing device manipulates and transforms data represented as physical (electronic) quantities within the electronic computing device’s processors, registers, and/or memories into other data similarly represented as physical quantities within the electronic computing device’s memories, registers and/or other such information storage, processing, transmission, or/or display components of the electronic computing device or other electronic computing device(s).

The term “handheld tool” is used often herein. By “handheld tool” what is meant is a man-portable device that is used in the construction trade. Some non-limiting examples of handheld tools include manual tools, power tools (e.g., tools powered by electricity, an internal battery, compressed air, an internal combustion engine, or the like), and powder-actuated tools. Handheld tools are often utilized for tasks such as drilling, sawing, cutting, and installing various types of fasteners.

Overview of Discussion

Example units, systems, and methods for construction site management and reporting are described herein. Discussion begins with a description of an information management network in accordance with one embodiment. Example units, systems, and methods for construction site management and reporting are described herein. Discussion continues with a description of an information management network in accordance with various embodiments along with description of some example configurations of components of the information management network. An example positioning infrastructure is described. An example reporting source is described, as are an example tool position detector and an example tool user interface. An example global navigation satellite system (GNSS) receiver is described. Discussion concludes with a description of reference based positioning of tools, assets, and materials on a construction site.

Information Management Network

FIG. 1 shows an information management network **100** in accordance with an embodiment. In FIG. 1, an information management system **101**, comprising computer **102** and database **103**, receives asset information (e.g., asset report **111**) from a reporting source **110**. In response to user requests, in response to the occurrence of a defined event, or automatically based upon a pre-determined time interval, information management system **101** generates reports **150** to positioning infrastructure **140**. Similarly, reporting source **110** can generate asset report **111** in response to user requests, in response to the occurrence of a defined event, or automatically based upon a pre-determined time interval. In accordance with various embodiments, task data **131** comprises data describing events, conditions, and parameters which are recorded at a site. For example, handheld tool **120** can be used to report operating parameters which were implemented upon handheld tool in the performance of a task. Similarly, handheld tool **120** can record the condition of an item such as a structure, a tool, etc. back to information

management system **101**. It is noted that the recording, and reporting, of this information can occur in real-time, and can include conditions before, during, and after a task have been performed. This information can be used to verify that operations performed by handheld tool **120** were performed in accordance with pre-determined parameters and can show the condition of the finished task. In general, reports **150** comprise data, warnings, or other messages which assist in the completion of a task. In one embodiment, positioning infrastructure **140** can generate position data **141** in response to report **150** which is used to assist an operator in positioning and orienting handheld tool **120** at the correct location to perform a particular task. In one embodiment, user interface **130** is used to direct the operator in positioning and orienting handheld tool **120**. It is noted that information management network **100**, as well as components thereof such as information management system **101**, can be implemented in a cloud computing environment in accordance with various embodiments.

In accordance with one embodiment, database **103** can store and retrieve task data **131** and use that data to generate reports **150**. The reports **150** can be used to convey details of a task to be performed such as the position where the task is to be performed, operating parameters when performing the task, alerts, updated scheduling information, or updated blueprints **105** based upon received task data **131**, etc. For example, report **150** may comprise a data file (e.g., a computer-aided design (CAD) file), or other building information modeling data, which shows the location within a room where certain tasks, such as drilling holes, are to be performed. Using this information, positioning infrastructure **140** can generate cues which the operator of handheld tool **120** uses to properly place the working end (e.g., the drill bit) at the correct location to drill a hole. Positioning infrastructure **140** can also generate cues which direct the operator to change the alignment/orientation of handheld tool **120** so that the hole is drilled in the proper direction. As a result, separate steps of laying out and marking the positions where operations are to be performed, as well as performing the actual operation itself, can be performed by a single operator in one step. Positioning infrastructure **140** is also configured to determine how far handheld tool **120** has traveled while performing a task, such as drilling a hole, and can generate a message telling the operator of handheld tool **120** to stop drilling when the hole is sufficiently deep. Alternatively, the message from positioning infrastructure **140** can cause handheld tool **120** to automatically shut down when a task is completed. In another embodiment, this message can be generated by information management system **101**. This is possible in part because handheld tool **120** is configured with a tool position detector **121**. As will be discussed in greater detail below, tool position detector **121** is configured to determine the position of the working end of handheld tool **120** based upon a local, or global reference system. Additionally, tool position detector **121** can be configured to determine the alignment/orientation (e.g., azimuth and tilt) of handheld tool **120**. Alternatively, tool position detector **121** is coupled with positioning infrastructure **140** rather than with handheld tool **120**.

Upon completion of a task, task data **131** is sent from handheld tool **120** to a reporting source **110**. Reporting source **110** then generates an asset report **111** to information management system **101** which facilitates tracking the progress of work at the construction site and automatically updating records such as blueprints **105** in real-time using record updater **107** so that they reflect the as-built configuration of the building. It is noted that the functions described

which are attributed to positioning infrastructure **140**, tool position detector **121**, user interface **130** and reporting source **110** can be implemented in a variety of configurations. In one embodiment, all of these functions are integrated into a single device. This device can be coupled with, mounted upon, or integrated within handheld tool **120**. In another embodiment, some of the above functions (e.g., reporting source **110**, positioning infrastructure **140**, and/or user interface **130**) can be integrated into a handheld device such as a personal computer system, personal digital assistant (PDA), a “smart phone”, or a dedicated device. This device is in communication with handheld tool **120** which further comprises tool position detector **121** and, optionally, an additional user interface **130**. It is noted that a plurality of handheld tools **120** can send task data to a reporting source **110** in accordance with one embodiment. Similarly, a plurality of handheld tools **120** can receive position data **141** from a single positioning infrastructure in accordance with one embodiment.

Additionally, information management system **101** can prevent inadvertent damage to structures within a building. As an example, blueprints **105** can contain information such as the location of mechanical, electrical, and plumbing features (e.g., pipes, electrical conduits, ventilation ducts, etc.) which have already been built, or will be later. Because asset report **111** provides real-time data on actions performed at a construction site, information management system **101** can determine whether an operator of handheld tool **120** is performing an action which may damage other structures or interfere with the installation of subsequent structures. Information management system **101** can generate a warning (e.g., report **150**) to the operator of handheld tool **120** prior to beginning a task so that the operator is aware of the potential damage that could be caused. In one embodiment, positioning infrastructure **140**, and information management system **101**, can monitor the position of handheld tool **120** in real-time and generate a message which causes handheld tool **120** to automatically shut down to prevent damaging other structures. Additionally, user interface **130** can display, for example, a picture of a wall with the underlying structures overlaid to represent their positions, or a blueprint of the wall with the same information. Again, this means that separate steps of laying out and marking the locations of existing structures are not necessary as the operator of handheld tool **120** can be provided that information directly.

Furthermore, due to the asset management capabilities described herein a significant business management tool is realized. That is, because information management system **101** is useful at all levels of asset management, the information management system **101** provides significant value added features. For example, the asset reports **111** can provide real-time reporting on the progress of a particular task to allow changing the workflow implemented at a construction site. Information management system **101** can also be used to track the maintenance schedule of handheld tool **120**, monitor the performance of handheld tool **120**, and to track the service life of “consumables” such as drill bits and saw blades. Furthermore, this can be linked with the material being worked upon. For example, knowing whether concrete or steel is being drilled can significantly change the parameters regarding the life of the consumables, safety, and operator performance, as well whether work is progressing at a satisfactory pace and/or whether to generate alerts.

As an example, if asset report **111** indicates that it is taking longer than expected to drill holes using handheld tool **120**, information management system **101** can determine whether

the drill bit being used by handheld tool **120** is in need of replacement, or if handheld tool **120** itself is in need of maintenance. Determination of how long it takes to perform a task can be based upon, for example, the start time and finish time for a task as reported by handheld tool **120**, or the distance handheld tool **120** has moved in performing a task as reported by positioning infrastructure **140**. Additionally, as the location of the consumables and handheld tools can be monitored by information management system **101**, the process of locating them in order to implement needed repairs is facilitated. This may also include maintaining inventory of consumables so that sufficient stores are maintained at the construction site to prevent unnecessary delays. Alternatively, it may be that an operator of handheld tool **120** is not exerting enough force which causes the drilling of holes to take longer than expected. In one embodiment, information management system **101** can make this determination and generate a report **150** in real-time to the operator of handheld tool **120** which explains that more force should be exerted upon handheld tool **120**. Additionally, information management system **101** can ensure that the proper tools, personnel, and other assets are at the correct location at the correct time to perform a particular task. As an example, information management system **101** can ensure that a generator is at the construction site to provide power to handheld tool **120** as well as the correct fasteners for a particular task. This data can also be used to track the life of handheld tools, consumables, etc., from various providers to determine which provider provides a superior product. For example, if drill bits from one provider have a service life 20% lower than those from a second provider, it may indicate that the second provider sells a superior product.

In another embodiment, information management system **101** can monitor workplace safety in real-time. For example, database **103** can maintain a record of what handheld tools a particular operator is allowed to use. In one embodiment, for example user interface **130** can identifier an operator via manual login (such as by operator input of a personally identifying code), automatic electronic login (such as by sensing an personally identifying information provided wirelessly by an RFID badge worn by the employee), or combination thereof. Thus, if the operator has not been trained how to operate a particular handheld tool, workplace safety, or other relevant information, information management system **101** can generate a report **150** which indicates this to the operator. In one embodiment, report **150** may disable handheld tool **120** such that the operator cannot use handheld tool **120** until the required training has been recorded in database **103**. Furthermore, information management system **101** can be used to monitor how quickly a particular operator is at performing a task. This information can be used to determine whether additional training and/or supervision is need for that particular operator. In various embodiments, additional sensor devices (e.g., sensors **550** of FIGS. 5A-5C) can be worn by a user and interact with handheld tool **120**. Examples of such sensors include, but are not limited to, sensors for recording vibration, dust, noise, chemicals, radiation, or other hazardous exposures which can be collected and reported to information management system **101** to be used as a record against possible health claims.

Additionally, information management system **101** can be used to monitor the quality of work performed at a construction site. As will be discussed in greater detail below, various sensors can be used to send task data **131** which provide metrics (e.g., operating parameters of handheld tool

120 during the performance of a task) for determining how well various operations have been performed. For example, a sensor coupled with handheld tool 120 can determine how much torque was applied to a fastener. This information can be used by, for example, building inspectors to assist them in assessing whether a building is being built in accordance with the building codes. In another example, a camera coupled with handheld tool 120 can capture an image, images, or video showing the work before, during, and after it is performed. The captured media can verify that the hole was cleanly drilled, did not damage surrounding structures, and that excess material was removed. Furthermore, asset report 111 can not only report what actions have been performed at the construction site, but can also report what materials were used or applied to complete a particular task. Asset report 111 can also be used to notify in real-time whether materials, or consumables, are being used at a greater than expected rate. For example, an operator can generate an asset report via user interface 130 which states that a given material (e.g., an adhesive) is not in stock at the construction site.

With reference now to FIG. 2, all or portions of some embodiments described herein are composed of computer-readable and computer-executable instructions that reside, for example, in computer-usable/computer-readable storage media of a computer system. That is, FIG. 2 illustrates one example of a type of computer system (computer 102 of FIG. 1) that can be used in accordance with or to implement various embodiments which are discussed herein. It is appreciated that computer system 102 of FIG. 2 is only an example and that embodiments as described herein can operate on or within a number of different computer systems including, but not limited to, general purpose networked computer systems, embedded computer systems, server devices, various intermediate devices/nodes, stand alone computer systems, handheld computer systems, multi-media devices, and the like. Computer system 102 of FIG. 2 is well adapted to having peripheral computer-readable storage media 202 such as, for example, a floppy disk, a compact disc, digital versatile disc, universal serial bus “thumb” drive, removable memory card, and the like coupled thereto.

Computer system 102 of FIG. 2 includes an address/data bus 204 for communicating information, and a processor 206A coupled to bus 204 for processing information and instructions. As depicted in FIG. 2, computer system 102 is also well suited to a multi-processor environment in which a plurality of processors 206A, 206B, and 206C are present. Conversely, computer system 102 is also well suited to having a single processor such as, for example, processor 206A. Processors 206A, 206B, and 206C may be any of various types of microprocessors. Computer system 102 also includes data storage features such as a computer usable volatile memory 208, e.g., random access memory (RAM), coupled to bus 204 for storing information and instructions for processors 206A, 206B, and 206C. Computer system 102 also includes computer usable non-volatile memory 210, e.g., read only memory (ROM), and coupled to bus 204 for storing static information and instructions for processors 206A, 206B, and 206C. Also present in computer system 102 is a data storage unit 212 (e.g., a magnetic or optical disk and disk drive) coupled to bus 204 for storing information and instructions. Computer system 102 also includes an optional alphanumeric input device 214 including alphanumeric and function keys coupled to bus 204 for communicating information and command selections to processor 206A or processors 206A, 206B, and 206C. Computer system 102 also includes an optional cursor control device

216 coupled to bus 204 for communicating user input information and command selections to processor 206A or processors 206A, 206B, and 206C. In one embodiment, computer system 102 also includes an optional display device 218 coupled to bus 204 for displaying information.

Referring still to FIG. 2, optional display device 218 of FIG. 2 may be a liquid crystal device, cathode ray tube, plasma display device, projector, or other display device suitable for creating graphic images and alphanumeric characters recognizable to a user. Optional cursor control device 216 allows the computer user to dynamically signal the movement of a visible symbol (cursor) on a display screen of display device 218 and indicate user selections of selectable items displayed on display device 218. Many implementations of cursor control device 216 are known in the art including a trackball, mouse, touch pad, joystick or special keys on alphanumeric input device 214 capable of signaling movement of a given direction or manner of displacement. In another embodiment, a motion sensing device (not shown) can detect movement of a handheld computer system. Examples of a motion sensing device in accordance with various embodiments include, but are not limited to, gyroscopes, accelerometers, tilt-sensors, or the like. Alternatively, it will be appreciated that a cursor can be directed and/or activated via input from alphanumeric input device 214 using special keys and key sequence commands. Computer system 102 is also well suited to having a cursor directed by other means such as, for example, voice commands. In another embodiment, display device 218 comprises a touch screen display which can detect contact upon its surface and interpret this event as a command. Computer system 102 also includes an I/O device 220 for coupling computer system 102 with external entities. For example, in one embodiment, I/O device 220 is a modem for enabling wired or wireless communications between system 102 and an external network such as, but not limited to, the Internet.

Referring still to FIG. 2, various other components are depicted for computer system 102. Specifically, when present, an operating system 222, applications 224, modules 226, and data 228 are shown as typically residing in one or some combination of computer usable volatile memory 208 (e.g., RAM), computer usable non-volatile memory 210 (e.g., ROM), and data storage unit 212. In some embodiments, all or portions of various embodiments described herein are stored, for example, as an application 224 and/or module 226 in memory locations within RAM 208, computer-readable storage media within data storage unit 212, peripheral computer-readable storage media 202, and/or other tangible computer-readable storage media.

FIG. 3 shows information management network 100 in accordance with an embodiment. As shown in FIG. 3, reporting source 110 receives data such as task data 131 from a handheld tools 120-A, 120-B, 120-C3-120-n. In accordance with various embodiments, positioning infrastructure 140 can generate data to a plurality of handheld tools 120 based upon information received via reports 150.

Similarly, reporting source 110 can also receive data from other sources such as operator(s) 310, consumables 320, materials 330, and other assets 340. Identification of these various data sources can be detected and reported automatically, or manually by operator 310 via user interface 130. In accordance with various embodiments, reporting source 110 can comprise a dedicated user interface 130, and other data sensing devices such as, but not limited to, radio-frequency identification (RFID) readers, magnetic card readers, barcode readers, or image capture devices which utilize image recognition software to identify objects. In accordance with

one embodiment, assets **340** comprise devices such as air compressors, extension cords, batteries, equipment boxes, fire extinguishers, or other equipment which are used at the construction site. As a result, information management system **101** can integrate data from a variety of sources in order to facilitate workflow, monitor performance, update blueprints **105** on a real-time basis, and generate reports based upon the received information.

FIG. **4** is a flowchart of a method **400** for managing information at a construction site in accordance with one embodiment. The flow chart of method **400** includes some procedures that, in various embodiments, are carried out by one or more processors under the control of computer-readable and computer-executable instructions. In this fashion, procedures described herein and in conjunction with the flow chart of method **400** are, or may be, implemented in an automated fashion using a computer, in various embodiments. The computer-readable and computer-executable instructions can reside in any tangible, non-transitory computer-readable storage media, such as, for example, in data storage features such as peripheral computer-readable storage media **202**, RAM **208**, ROM **210**, and/or storage device **212** (all of FIG. **2**) or the like. The computer-readable and computer-executable instructions, which reside on tangible, non-transitory computer-readable storage media, are used to control or operate in conjunction with, for example, one or some combination of processor(s) **206** (see FIG. **2**), or other similar processor(s). Although specific procedures are disclosed in the flow chart of method **400**, such procedures are examples. That is, embodiments are well suited to performing various other procedures or variations of the procedures recited in the flow chart of method **400**. Likewise, in some embodiments, the procedures in the flow chart of method **400** may be performed in an order different than presented and/or not all of the procedures described may be performed. It is further appreciated that procedures described in the flow chart of method **400** may be implemented in hardware, or a combination of hardware with firmware and/or software.

In operation **410** of FIG. **4**, task data is received from a handheld tool at a construction site. As described above, handheld tool **120** is configured to generate task data which is sent via reporting source **110** to information management system **101**.

In operation **420** of FIG. **4**, a database is populated with the task data such that the task data can be retrieved from the database. In one embodiment, task data **131** is received in asset report **111**. This data can be stored in database **103** for later use such as to generate reports **150**. The task data **131** can also be used to automatically update blueprints **105** to reflect the as-built configuration of a building or other structure. The term "as-built" means the actual configuration of features within the building which may, or may not, differ from the original blueprints. For example, a pipe may have to be routed around a beam in the original blueprints. However, as the building is being constructed, it is discovered that the pipe in fact does not have to be routed around the beam. Thus, the as-built configuration found in the updated blueprints shows the location of the pipe which was not routed around the beam. In accordance with various embodiments, the location, disposition, and configuration of structural elements, or other components, at a construction site can be recorded and reported using information management network **100**. For example, handheld tool **120**, positioning infrastructure **140**, or reporting source **110** can be configured to report the completion of tasks, including parameters implemented in the completion of those tasks, to information management system **101**.

In operation **430** of FIG. **4**, the task data is used to generate at least one report. In accordance with one embodiment, the task data **131** is used to update records at information management system **101**. As a result, report **150** can generate instructions, messages, warnings, or the like based upon real-time conditions at the building site.

Example Configurations of Components of Information Management Network

FIGS. **5A**, **5B**, and **5C** show different configurations of components of information management network, in accordance with various embodiments. It is noted the configurations shown in FIGS. **5A**, **5B**, and **5C** are for purposes of illustration only and that embodiments of the present technology are not limited to these examples alone. In FIG. **5A**, an operator device **510** (e.g., handheld tool **120**) comprises reporting source **110**, user interface **130**, tool position detector **121**, positioning infrastructure **140**, and sensors **550**.

In accordance with one embodiment, operator device **510** is a stand-alone device coupled with a housing **520**. In accordance with various embodiments, housing **520** is comprised of a rigid or semi rigid material or materials. In one embodiment, all or a portion of housing **520** is made of an injection molded material such as high impact strength polycarbonate. In one embodiment, housing **520** is transparent to global navigation satellite system (GNSS) satellite signals such as signals which can be received by tool position detector **121** and/or positioning infrastructure **140**. In the embodiment of FIG. **5A**, operator device **510** is configured to be coupled with handheld tool **120**. For example, operator device **510** can be removably coupled with handheld tool **120** using a clip-on bracket. In another embodiment, operator device **510** can be coupled with handheld tool **120** using mechanical fasteners such as screws. While not shown in FIG. **5A**, when operator device **510** is configured as a stand-alone device it is powered by a battery.

In another embodiment, operator device **510** comprises an integral component of handheld tool **120**. In this embodiment, housing **520** comprises the housing of handheld tool **120** itself. In one embodiment, operator device **510** can draw power directly from handheld tool **120**.

In accordance with various embodiments, sensors **550** comprise devices which collect information for operator device **510**. Examples of sensors **550** include, but are not limited to, an image capture device (or plurality thereof), a depth camera, a laser scanner, an ultrasonic ranging device, a laser range finder, a barcode scanner, an RFID reader, or the like. Sensors **550** may also identify an operator via wireless communication with an operator identification device (e.g., a badge with an RFID coded with operator unique information). A barcode scanner, or RFID reader, can be used to quickly identify objects, or consumables used by handheld tool **120**. For example, each drill bit, saw blade, or other consumable can be configured with a barcode, or RFID tag, which provides a unique identifier of that object. Using this information, operator device **510** can access information which correlates that identifier with other characteristics of that object. As an example, a drill bit can be provided with an RFID tag providing a unique identifier to operator device **510**. Operator device **510** then accesses a local, or remote, database and determines that the identified object is a $\frac{3}{4}$ inch drill bit which is 8 inches long. This information can be used by operator device **510** to facilitate properly performing a task as well as provide information which can be included in task data **131** which is forwarded to information manage-

ment system **101**. In one embodiment, operating parameters of operator device **510** can be configured, either manually or automatically, based upon information from report **150** from information management system **101**. This information can be used by the operator of handheld tool **120** to verify that he is using the correct drill bit, as well as for later verification that the task was performed up to standard. Also, data can be sent from operator device **510** conveying its settings or operating parameters back to information management system **101**. A user of information management system **101** can also use this information to track the use of that drill bit to determine whether it is time to replace it. In another example, sensors **550** can verify that the correct type of fire-proofing material was used by the operator of handheld tool **120**. The use of a camera allows an operator of handheld tool **120** to capture an image of the work performed to verify that the task was performed correctly such as at the correct location and in a manner which complies with applicable standards. It is noted that a plurality of operator devices **510** can be communicatively coupled in a mesh network to permit communications between a plurality of handheld tools **120**. Thus, in one embodiment, one handheld tool **120** can relay information to a second handheld tool **120**. Operator device **510** can also determine and forward information regarding what materials were used to perform a task (e.g., what type of fastener was used), as well as parameters about the task which was performed such as the torque applied to a nut, or the force used to drive an anchor into a substrate. Operator device **510** can also provide real-time metrics during the course of the task being performed. This permits remote monitoring and/or control of the process from another location such as from information management system **101**.

In FIG. **5B**, operator device **510** comprises reporting source **110**, user interface **130**, tool position detector **121**, and sensors **550**. A separate building site device **530** comprising positioning infrastructure **140** is located in the vicinity of operator device **510**. Positioning infrastructure **140** comprises sensors, wired and wireless communication components, processors, and software instructions which are disposed in a housing **540** and which facilitate building site device **530** in generating instructions to operator device **510**. A more detailed description of these components follows with reference to FIG. **6**.

In accordance with various embodiments, building site device **530** is configured to receive report(s) **150** from information management system **101** and to relay some or all of this information to operator device **510**. In accordance with various embodiments, building site device **530** can be precisely placed at a set of coordinates in the vicinity of the construction site. By determining the azimuth, direction, and elevation from building site device **530** to other points, building site device **530** can provide positioning cues to operator device to assist an operator in properly placing handheld tool **120** to perform a task. This is possible in part because building site device **530** receives instructions via report **150** such as blueprints **105**. Building site device **530** can correlate the features shown in blueprints **105** with its current position to determine where those features are to be located at the building site. Furthermore, avoidance zones can be defined where certain actions are not permitted. For example, if rebar is embedded 6 inches deep within a concrete pillar, it may be permissible to drill down 2 inches into the pillar above the rebar, but no deeper to prevent inadvertently hitting the rebar. It may be necessary to use a certain type of adhesive for a task based upon the substances being glued. In accordance with embodiments of the present

technology, this information can be sent to operator device **510** through information management network **100**.

As an example, building site device **530** can be placed in a space of a building where a room is being built. Using, for example, a GNSS receiver, building site device **530** can precisely determine its own geographic position. Using the information from blueprints **105**, building site device **530** can then determine where features of that room are to be located. For example, building site device **530** can determine the location and distance to the walls of the room being built, as well as other features such as pipes, conduits, structural members and the like which will be disposed in the space behind the wall. It is important for an operator of handheld tool **120** to know the location of these features as well in order to prevent inadvertent damage, or to perform tasks which are intended to tie in with these features. For example, it may be desired to drill through sheetrock into underlying studs in a wall. Building site device **530** can determine where these features are located relative to its own position by leveraging the knowledge of its own position and the data from blueprints **105**.

In accordance with various embodiments, building site device **530** is also configured to detect the position and/or orientation of handheld tool **120** and to generate instructions which facilitate correctly positioning and orienting it to perform a task. For example, if a hole is to be drilled in a floor, building site device **530** can access blueprints **105** and determine the location, angle, and desired depth of that hole and correlate that information with the location and orientation of handheld tool **120**. Building site device **530** then determines where that hole is to be located relative its own location. Building site device **530** then generates one or more messages to operator device **510** which provide positioning cues such that an operator of handheld tool **120** can correctly position the working end (e.g., the drill bit tip) at the location where the hole is to be drilled. It is noted that a series of communications between building site device **530** and operator device **510** may occur to correctly position the working end of handheld tool **120** at the correct location.

Additionally, building site device **530** may use position and/or orientation information generated by tool position detector **121** to facilitate the process of positioning and orienting handheld tool **120**. In one embodiment, once the working end of handheld tool **120** is correctly positioned, building site device **530** can generate one or more messages to facilitate correctly orienting handheld tool **120**. This is to facilitate drilling the hole at the correct angle as determined by blueprints **105**. It is noted that these actions can be performed by operator device **510** of FIG. **5A** as described above. In accordance with various embodiments, multiple building site devices **530** can be positioned at a construction site which are communicatively coupled with each other in a mesh network and with one or more handheld tools **120**. It is noted that in one embodiment, user interface **130** comprises an operator wearable transparent display which projects data, such as the location of hidden structures (e.g., pipes or rebar) to the operator. For example heads-up display (HUD) glasses exist which use an organic light emitting diode (OLED) to project data for a wearer. In one embodiment, a wearer of these glasses can see a projection of objects which the operator may want to avoid such as rebar, as well the position at which a task is to be performed. For example, if a hole is to be drilled at a certain location, that location can be projected onto the glasses so that when a user is looking at a wall, the position where the hole will be drilled is displayed by the glasses at the proper location on the wall. Building site device **530** can provide data or images

which are projected or displayed directly by a LED or laser projector, or by such HUD glasses, and additionally such HUD glasses may serve a dual purpose of providing eye protection (e.g., as safety glasses) for an operator when operating an handheld tool.

In FIG. 5C, operator device 510 comprises a user interface 130, tool position detector 121, and sensors 550 while building site device 530 comprises reporting source 110, user interface 130, and positioning infrastructure 140. FIG. 5C represents an embodiment in which the functions of reporting source 110 and positioning infrastructure 140 are removed from the operator of handheld tool 120, or from handheld tool 120 itself. In one embodiment, building site device 530, as represented in FIGS. 5B and 5C, can provide positioning and/or orientation information to a plurality of operator devices 510. It is noted that in accordance with various embodiments, user interface 130 may be configured differently. For example, in one embodiment, user interface 130 comprises a touch screen display which is capable of displaying characters, menus, diagrams, images, and other data for an operator of handheld tool 120. In another embodiment, user interface may comprise an array of LED lights which are configured to provide visual cues which facilitate positioning the working end of handheld tool 120 at a given position and the alignment of handheld tool 120 as well. In one embodiment, the display of visual cues is in response to messages generated by building site device 530 and/or operator device 510.

There are a variety of instruments which can be configured to serve the function of building site device 530. One example instrument which can be configured to perform the functions of building site device 530 is a pseudolite which is used to provide localized position information, such as GNSS signal data to operator device 510. Another example instrument which can be configured to perform the functions of building site device 530 is a robotic total station. One example of a robotic total station is the S8 Total station which is commercially available from Trimble Navigation Limited of Sunnyvale, Calif. Another example of an instrument which can be configured to perform the functions of building site device 530 is a virtual reference station (VRS) rover which uses networked real-time kinematics corrections to determine its location more precisely. One example of a VRS rover is the R8 VRS which is commercially available from Trimble Navigation Limited of Sunnyvale, Calif.

Example Positioning Infrastructure

FIG. 6 is a block diagram of an example positioning infrastructure 140 in accordance with one embodiment. In FIG. 6, positioning infrastructure 140 comprises sensors 610, a data receiver 620, one or more communication transceivers 630, an antenna 640, and a power source 650. In accordance with various embodiments, sensors 610 are configured to detect objects and features around positioning infrastructure 140. Some objects include, but are not limited to, handheld tool 120, operators 310, consumables 320, materials 330, and assets 340 as described in FIG. 3. Sensors 610 are also configured to detect objects pertaining to a construction site such as buildings, wall, pipes, floors, ceilings, vehicles, etc. Sensors 610 further comprise devices for determining the position of positioning infrastructure 140 such as a GNSS receiver (e.g., GNSS receiver 1000 of FIG. 10), radio receiver(s), and the like. In another embodiment, the position of positioning infrastructure 140 can be manually entered by an operator using a user interface 130

coupled therewith. It is noted that other objects and features described above can also be manually entered via user interface 130 as well. Examples of sensors 610 in accordance with various embodiments include, but are not limited to, an image capture device, or plurality thereof, an ultrasonic sensor, a laser scanner, a laser range finder, a barcode scanner, an RFID reader, sonic range finders, a magnetic swipe card reader, a radio ranging device, or the like. It is noted that information received via communication transceiver(s) 630 can also be used to detect and/or identify features and objects as well. In accordance with one embodiment, photogrammetric processing of a captured image (e.g., by information management system 101, or positioning infrastructure 140) can be used to detect and/or identify features and objects.

In one embodiment, the location of cameras for photogrammetric processing can be determined by information management system 101 based upon what task is to be performed. For example, if a particular wall is to be drilled, information management system 101 can determine where to place cameras in order to capture images which facilitate photogrammetric processing to determine various parameters of the task being performed. Thus, the location where the working end of the drill bit, depth of drilling, angle of drilling, and other parameters can be determined using photogrammetric processing of images captures by sensors 610. Alternatively, a user can choose where to place the cameras in order to capture images to be used in photogrammetric processing. In another embodiment, cameras can be placed in each corner of a room to capture images of the entire area. In accordance with one embodiment, positioning infrastructure 140 can calculate the respective positions of cameras within a work space by detecting known points from a BIM model. For example, I-beams, or room corners, can be readily identified and, based on their known position, the position of the cameras which have captured those features can be determined. Again, this processing of images, as well as other photogrammetric processing, can be performed by information management system 101 and/or positioning infrastructure 140.

In accordance with one embodiment, when handheld tool 120 is brought into a workspace in which the cameras have been placed, it is captured by at least one camera and its position can be determined by image recognition and triangulation. The orientation of handheld tool 120 can be determined using multiple cameras to determine the roll, pitch, and yaw. Also, the position of the working end of handheld tool 120 can be processed in a similar manner. In accordance with one embodiment, this information can be conveyed to handheld tool 120 to provide real-time feedback to an operator of the position and orientation of handheld tool 120. In one embodiment, the cameras comprising sensors 610 can view multiple handheld tools 120 simultaneously and provide real-time position and orientation information to respective operators of those handheld tools. Additionally, new cameras can be added to adjacent or next work areas and integrated into existing area camera networks to facilitate moving handheld tool 120 to other areas, or to extend coverage of positioning infrastructure 140 in large areas where camera angle and/or range is not adequate.

Data receiver 620 comprises a computer system similar to that described above with reference to FIG. 2. In accordance with various embodiments, data receiver 620 receives reports 150, or other data, and uses this information to generate messages to, for example, operator device 510. As described above, reports 150 can convey CAD files, or other building information modeling data, which describes the

location where various objects and structures are to be built at a construction site. Because positioning infrastructure **140** is aware of its own geographic position, it can correlate where these objects and structures are to be located relative to its own location in a local or global coordinate system. As an example, the angle and distance to each pixel in a captured image can be calculated by data receiver **620** in one embodiment. In accordance with various embodiments, positioning infrastructure **140** can generate messages and instructions to operator device **510** which assist in positioning and orienting handheld tool **120** to perform a task. It is noted that some components as described above with reference to FIG. 2, such as processors **206B** and **206C**, may be redundant in the implementation of data receiver **620** and can therefore be excluded in one embodiment. It is noted that information relating to settings of handheld tool **120** can be relayed via data receiver **620**. For example, leveraging knowledge of a material which is being worked on, information on the desired operating parameters (e.g., speed, torque, RPMs, impact energy, etc.) for handheld tool **120** can be forwarded directly to handheld tool **120**. As a result, operator error in setting the parameters for a handheld tool **120** can be reduced.

Communication transceivers **630** comprise one or more wireless radio transceivers coupled with an antenna **640** and configured to operate on any suitable wireless communication protocol including, but not limited to, WiFi, WiMAX, WWAN, implementations of the IEEE 802.11 specification, cellular, two-way radio, satellite-based cellular (e.g., via the Inmarsat or Iridium communication networks), mesh networking, implementations of the IEEE 802.15.4 specification for personal area networks, and implementations of the Bluetooth® standard. Personal area network refer to short-range, and often low-data rate, wireless communications networks. In accordance with various embodiments, communication transceiver(s) **630** are configured to automatic detection of other components (e.g., communication transceiver(s) **720**, **820**, and **920** of FIGS. 7, 8, and 9 respectively) and for automatically establishing wireless communications. It is noted that one communication transceiver **630** can be used to communicate with other devices in the vicinity of positioning infrastructure **140** such as in an ad-hoc personal area network while a second communication transceiver **630** can be used to communicate outside of the vicinity positioning infrastructure **140** (e.g., with information management system **101**). Also shown in FIG. 6 is a power source **650** for providing power to positioning infrastructure **140**. In accordance with various embodiments, positioning infrastructure **140** can receive power via an electrical cord, or when implemented as a mobile device by battery.

Example Reporting Source

FIG. 7 is a block diagram of an example reporting source **110** in accordance with one embodiment. In the embodiment of FIG. 7, reporting source **110** comprises a data receiver **710**, a communication transceiver(s) **720**, an antenna **730**, and a power source **740**. For the purposes of brevity, the discussion of computer system **102** in FIG. 2 is understood to describe components of data receiver **710** as well. Data receiver **710** is configured to receive task data **131** generated by, for example, operator device **510** and building site device **530** which describe events, conditions, operations, and objects present at a construction site. Data receiver **710** is also configured to convey this task data **131** in the form of an asset report **111** to information management system **101**. It is noted that asset report **111** may comprise an abbreviated

version of the task data **131**, or may comprise additional data in addition to task data **131**. In one embodiment, asset report **111** comprises a compilation of multiple instances of task data collected over time from a single operator device **510**, or building site device **530**. In another embodiment, asset report **111** comprises a compilation of multiple instances of task data **131** generated by a plurality of operator devices **510**, or building site devices **530**. In accordance with various embodiments, reporting source **110** can generate asset report **111** periodically when a pre-determined time interval has elapsed, as a result of a request or polling from information management system **101**, or as a result of receiving task data **131** from an operator device **510** or building site device **530**. It is noted that a user of operator device **510** or building site device **530** can also initiate generating asset report **111**.

Reporting source **110** further comprises communication transceiver(s) **720** which are coupled with antenna **730** and a power source **740**. Again, for the purposes of brevity, the discussion of communication transceiver(s) **630**, antenna **640**, and power source **650** of FIG. 6 is understood to describe communication transceiver(s) **720**, antenna **730**, and power source **740**, respectively, of reporting source **110** as well.

Example Tool Position Detector

FIG. 8 is a block diagram of an example tool position detector **121** in accordance with one embodiment. In FIG. 8, tool position detector **121** comprises an optional position determination module **810**, communication transceiver(s) **820**, antenna **830**, and orientation sensors **840**. In accordance with various embodiments, tool position detector **121** is configured to detect and report the orientation, and optionally, the position of handheld tool **120**. It is noted that in accordance with various embodiments, the position of handheld tool **120** can be determined by building site device **530** rather than a device co-located with handheld tool **120**. In one embodiment, position determination module **810** comprises a GNSS receiver (e.g., GNSS receiver **1000** of FIG. 10), or another system capable of determining the position of handheld tool **120** with a sufficient degree of precision. It is noted that the position of, for example, antenna **1032** of FIG. 10, can be offset by a user interface **130** coupled with handheld device to more precisely reflect the working end of handheld tool **120**. For example, if handheld tool **120** is coupled with a drill bit, user interface **130** of operator device **510** can apply an offset (e.g., 3 centimeters lower and 100 centimeters forward of the position of antenna **1032**). In another embodiment, position determination module **810** utilizes a camera which captures images of structures and implements photogrammetric processing techniques to these images to determine the position of handheld tool **120**. In at least one embodiment, the captured image can be sent to another component of information management network **100** (e.g., to information management system **101**, or to positioning infrastructure **140**) to perform the photogrammetric processing of the image captured by position determination module **810**. In one embodiment, operator device **510** can use sensors **550** can automatically provide information which identifies a consumable coupled with which handheld tool **120** is coupled. Operator device **510** can then identify characteristics of that consumable so that the working end of handheld tool **120**, when coupled with that consumable, can be known. Alternatively, information identifying a consumable can be manually entered by an operator of handheld tool **120** via user interface **130**.

Again, for the purposes of brevity, the discussion of communication transceiver(s) **630** and antenna **640** of FIG. **6** is understood to describe communication transceiver(s) **820** and antenna **830** respectively of reporting source tool position detector **121** as well. Orientation sensor(s) **840** are configured to determine the orientation of handheld tool **120** in both an X Y plane, as well as tilt of handheld tool **120** around an axis. In accordance with various embodiments, orientation sensors comprise, but are not limited to, azimuth determination devices such as electronic compasses, as well as inclinometers (e.g., operable for determination of tilt in 3 axes), gyroscopes, accelerometers, depth cameras, multiple GNSS receivers or antennas, magnetometers, distance measuring devices, etc., which can determine whether handheld tool **120** is correctly aligned along a particular axis to perform a task. This facilitates correctly orienting/aligning handheld tool **120** above a designated position in order to perform a task. Using a drill as an example, once the end of the drill bit coupled with handheld tool **120** has been positioned above the location where the hole is to be drilled (e.g., using cues provided by position determination module **810** and/or a GNSS receiver **1000** disposed within positioning infrastructure **140** of operator device **510** and/or building site device **530**) orientation sensors **840** are used to determine whether handheld tool **120** is properly aligned to drill the hole as desired. It is noted that in one embodiment, a series of communications between operator device **510** and building site device **530** may be exchanged in the process of correctly orienting/aligning handheld tool **120**. In one embodiment, tool position detector **121** communicates with a user interface **130** of operator device **510** to provide cues to guide the operator of handheld tool **120** in correctly aligning handheld tool **120** along the correct axis. As the operator changes the axis of handheld tool **120** in response to visual cues displayed on user interface **130**, orientation sensors **840** will determine the orientation/alignment of handheld tool **120**. When it is determined that handheld tool **120** is aligned within pre-determined parameters, an indication is displayed and/or annunciated to the operator of handheld tool **120** via user interface **130**.

Example User Interface

FIG. **9** is a block diagram of an example user interface **130** in accordance with one embodiment. In FIG. **9**, user interface **130** comprises a data receiver **910**, communication transceiver(s) **920** coupled with antenna **930**, and a power source. For the purposes of brevity, the discussion of computer system **102** in FIG. **2** is understood to describe components of data receiver **910** as well. Also, for the purposes of brevity, the discussion of communication transceiver(s) **630**, antenna **640**, and power source **650** of FIG. **6** is understood to describe communication transceiver(s) **920**, antenna **930**, and power source **940** respectively of user interface **130** as well. The user interface **130** is capable of communicating with tool position detector **121**, is operable for receiving data, displaying data to an operator of handheld tool **120**, detecting and/or selecting materials, assets, consumables, and personnel, reporting operating parameters of handheld tool **120**, and reporting task data describing the performance of a task. In one embodiment, user interface **130** is coupled with, or is integral to, handheld tool **120**. In another embodiment, user interface **130** can be disposed in a separate device (e.g., operator device **510** or building site

device **530**). As discussed above, in one embodiment user interface **130** comprises a user wearable display such as a set of heads-up display glasses.

Example GNSS Receiver

FIG. **10**, shows an example GNSS receiver **1000** in accordance with one embodiment. It is appreciated that different types or variations of GNSS receivers may also be suitable for use in the embodiments described herein. In FIG. **10**, received L1 and L2 signals are generated by at least one GPS satellite. Each GPS satellite generates different signal L1 and L2 signals and they are processed by different digital channel processors **1052** which operate in the same way as one another. FIG. **10** shows GPS signals (L1=1575.42 MHz, L2=1227.60 MHz) entering GNSS receiver **1000** through a dual frequency antenna **1032**. Antenna **1032** may be a magnetically mountable model commercially available from Trimble Navigation of Sunnyvale, Calif. Master oscillator **1048** provides the reference oscillator which drives all other clocks in the system. Frequency synthesizer **1038** takes the output of master oscillator **1048** and generates important clock and local oscillator frequencies used throughout the system. For example, in one embodiment frequency synthesizer **1038** generates several timing signals such as a 1st (local oscillator) signal LO1 at 1400 MHz, a 2nd local oscillator signal LO2 at 175 MHz, an SCLK (sampling clock) signal at 25 MHz, and a MSEC (millisecond) signal used by the system as a measurement of local reference time.

A filter/LNA (Low Noise Amplifier) **1034** performs filtering and low noise amplification of both L1 and L2 signals. The noise figure of GNSS receiver **1000** is dictated by the performance of the filter/LNA combination. The downconverter **1036** mixes both L1 and L2 signals in frequency down to approximately 175 MHz and outputs the analogue L1 and L2 signals into an IF (intermediate frequency) processor **1050**. IF processor **1050** takes the analog L1 and L2 signals at approximately 175 MHz and converts them into digitally sampled L1 and L2 inphase (L1 I and L2 I) and quadrature signals (L1 Q and L2 Q) at carrier frequencies 420 KHz for L1 and at 2.6 MHz for L2 signals respectively. At least one digital channel processor **1052** inputs the digitally sampled L1 and L2 inphase and quadrature signals. All digital channel processors **1052** are typically are identical by design and typically operate on identical input samples. Each digital channel processor **1052** is designed to digitally track the L1 and L2 signals produced by one satellite by tracking code and carrier signals and to from code and carrier phase measurements in conjunction with the microprocessor system **1054**. One digital channel processor **1052** is capable of tracking one satellite in both L1 and L2 channels. Microprocessor system **1054** is a general purpose computing device which facilitates tracking and measurements processes, providing pseudorange and carrier phase measurements for a navigation processor **1058**. In one embodiment, microprocessor system **1054** provides signals to control the operation of one or more digital channel processors **1052**. Navigation processor **1058** performs the higher level function of combining measurements in such a way as to produce position, velocity and time information for the differential and surveying functions. Storage **1060** is coupled with navigation processor **1058** and microprocessor system **1054**. It is appreciated that storage **1060** may comprise a volatile or non-volatile storage such as a RAM or ROM, or some other computer-readable memory device or media. In one

rover receiver embodiment, navigation processor **1058** performs one or more of the methods of position correction.

In some embodiments, microprocessor **1054** and/or navigation processor **1058** receive additional inputs for use in refining position information determined by GNSS receiver **1000**. In some embodiments, for example, corrections information is received and utilized. Such corrections information can include differential GPS corrections, RTK corrections, and wide area augmentation system (WAAS) corrections.

Reference Based Positioning of Tools, Assets, and Materials on a Building Construction Site

As in other industries, in the construction trade greater efficiency and cost reduction provides a competitive advantage. In accordance with various embodiments of the present technology, integration of positioning devices within handheld tool **120** increases the speed and efficiency in performing many tasks performed at a construction site. For example, layout of the construction site and marking the location of various features can consume over $\frac{1}{4}$ of the total time spent to complete a project and can be the greatest single time consuming task performed at a construction site. However, using information management network **100** as shown in FIG. **1**, the time spent in layout of the site can be greatly reduced. For example, the layout of already installed features such as pipes, structural members, rebar, etc., does not have to be performed because that information can be forwarded directly to the operator of handheld tool **120**. Additionally, because the location of these features can be precisely determined using various positioning technologies described above, the operator of handheld tool **120** can avoid inadvertent damage to these features, or can more accurately tie in his actions with these structures when desired. Often, one result of inadvertently damaging these features is the time and money spent to repair the damage. Another advantage is that handheld tool **120** can direct an operator to a particular portion of a construction site where a task is to be performed and then assist the operator in precisely positioning the working end of handheld tool **120** at the location where the task is to be performed and then in aligning handheld tool **120** in the performance of a task without the necessity of a separate prior step of measuring and marking the location where this task is to be performed. Thus, the amount of time spent in the time consuming process of laying out and marking the building site can be reduced using embodiments of the present technology.

As discussed above, information management network **100** can be used to identify tools, assets, personnel, and materials at a particular time and place in order to perform needed tasks more efficiently. Furthermore, the capability to record this information in information management system **101** facilitates quality control verification, personnel evaluation, inventory management, updating records, and scheduling. By integrating positioning technology with handheld tools, greater productivity can be realized at the construction site by reducing the amount of layout performed prior to using handheld tool **120**. This also results in increased positioning quality by reducing the number of people involved in a particular task, which can multiply human errors. This also minimizes re-work of tasks due to human error and reduces costs by consolidating the layout and task performance to a single operator. An additional benefit is that assets can be positioned at the correct time and place which again increases productivity.

FIG. **11** is a flowchart of a method **1100** of positioning handheld tools in accordance with at least one embodiment. The flow chart of method **1100** includes some procedures that, in various embodiments, are carried out by one or more processors under the control of computer-readable and computer-executable instructions. In this fashion, procedures described herein and in conjunction with the flow chart of method **1100** are, or may be, implemented in an automated fashion using a computer, in various embodiments. The computer-readable and computer-executable instructions can reside in any tangible, non-transitory computer-readable storage media, such as, for example, in data storage features such as peripheral computer-readable storage media **202**, RAM **208**, ROM **210**, and/or storage device **212** (all of FIG. **2**) or the like. The computer-readable and computer-executable instructions, which reside on tangible, non-transitory computer-readable storage media, are used to control or operate in conjunction with, for example, one or some combination of processor(s) **206** (see FIG. **2**), or other similar processor(s). Although specific procedures are disclosed in the flow chart of method **1100**, such procedures are examples. That is, embodiments are well suited to performing various other procedures or variations of the procedures recited in the flow chart of method **1100**. Likewise, in some embodiments, the procedures in the flow chart of method **1100** may be performed in an order different than presented and/or not all of the procedures described may be performed. It is further appreciated that procedures described in the flow chart of method **1100** may be implemented in hardware, or a combination of hardware with firmware and/or software.

In operation **1110**, information is received at a handheld tool for positioning a working end of the handheld tool at a desired position. As discussed above, handheld tool **120** is configured with tool position detector **121** in at least one embodiment. As discussed above with reference to FIG. **8**, tool position detector **121** comprises a position determination module **810** (e.g., a GNSS receiver) which permits handheld tool **120** to determine the location of a working end of handheld tool **120** such as the working end of an implement or consumable coupled with handheld tool **120**.

In operation **1120** of FIG. **11**, instructions are received at the handheld tool for aligning the handheld tool at the desired position. As described above, in at least one embodiment tool position detector **121** also comprises one or more orientation sensors **840** configured to determine the orientation of handheld tool **120** around an axis. Thus, when the working end of handheld tool **120** is located at a desired location as described in operation **1110**, user interface **130** can display the alignment instructions to facilitate orienting handheld tool **120** around an axis. As a result, the location and orientation of handheld tool **120** to perform a given task can be conveyed from information management system **101** in real-time to handheld tool **120**. This facilitates the construction process as separate steps of laying out, for example, where to drill a hole, then locating and orienting the drill can be integrated using information management network **100**.

Embodiments of the present technology are thus described. While the present technology has been described in particular embodiments, it should be appreciated that the present technology should not be construed as limited to these embodiments alone, but rather construed according to the following claims.

What is claimed is:

1. A method for positioning and orienting a handheld tool comprising:

21

receiving, at said handheld tool from an entity that is not within a structure that said handheld tool will perform a task on, information for positioning a working end of said handheld tool at a desired position with respect to said structure, wherein the desired position is different than a current position of said handheld tool;

displaying, on said handheld tool, at least one cue for positioning said working end of said handheld tool at said desired position;

receiving, at said handheld tool from said entity, instructions for orienting said handheld tool at said desired position to a desired orientation, wherein the desired orientation is different than a current orientation of said handheld tool; and

displaying, on said handheld tool, at least one cue for aligning said handheld tool to said desired orientation.

2. The method of claim 1 further comprising:
receiving at said handheld tool an operating parameter of said handheld tool to perform a task.

3. The method of claim 1 further comprising:
automatically detecting by said handheld tool an identification of a consumable item coupled with said handheld tool; and
determining an offset of a working end of said consumable item relative to an antenna of a Global Navigation Satellite System (GNSS) antenna coupled with said handheld tool.

4. The method of claim 1 further comprising:
communicatively coupling said handheld tool with a positioning infrastructure;
receiving by said positioning infrastructure a report conveying said desired position and orientation;
wirelessly sending said desired position and orientation to said handheld tool; and
displaying said desired position and orientation using a user interface coupled with said handheld tool.

5. The method of claim 4 wherein said positioning infrastructure comprises a separate device from said handheld tool, said method further comprising:
determining the position of said positioning infrastructure;
determining the position and orientation of said handheld tool and said desired position and orientation relative to said positioning infrastructure; and
generating by said positioning infrastructure the information for positioning said working end of said handheld tool to said desired position and the instructions for orienting said handheld tool at said desired position to said desired orientation.

6. The method of claim 1 further comprising:
displaying an image which conveys said desired position and orientation of said working end of said handheld tool.

7. The method of claim 6 further comprising:
projecting said image using a set of heads-up display (HUD) glasses.

8. The method of claim 1 further comprising:
displaying the location of said structure proximate to said desired position.

9. A handheld tool comprising:
a data receiver configured to receive, from an entity that is not within a structure that said handheld tool will perform a task on, positioning information describing a desired position of a working end of said handheld tool to perform said task on said structure, wherein the desired position is different than a current position of said handheld tool, said data receiver further configured

22

to receive a set of alignment data for orienting said handheld tool when said working end is situated at said desired position;

a display integrated with said handheld tool and configured to display, on said handheld tool, at least one cue for positioning said working end of said handheld tool at said desired position and at least one cue for orienting said handheld tool at said desired position to a desired orientation, wherein the desired orientation is different than a current orientation of said handheld tool; and

a tool position detector configured to provide data verifying that said working end of said tool is located at said desired position and that said handheld tool is oriented in accordance with said alignment data.

10. The handheld tool of claim 9 wherein said data receiver is further configured to receive an operating parameter of said handheld tool to perform a task.

11. The handheld tool of claim 9 further comprising:
a tool position detector comprising at least one sensor for automatically detecting an identification of a consumable item coupled with said handheld tool; and
a Global Navigation Satellite System (GNSS) position determination device, and wherein said tool position detector is configured to determine an offset of a working end of said consumable item relative to an antenna of said GNSS position determination device.

12. The handheld tool of claim 9 further comprising:
a wireless communication transceiver for communicatively coupling said handheld tool with a positioning infrastructure and wherein said positioning infrastructure wirelessly conveys said desired position and orientation to said handheld tool; and
a user interface for displaying said desired position and orientation.

13. The handheld tool of claim 12 wherein said positioning infrastructure comprises a separate device from said handheld tool, and wherein said positioning infrastructure is configured to determine its position, determine the position of said handheld tool and said desired position relative to said positioning infrastructure, and to generate the positioning information describing said desired position of a working end of said handheld tool and said set of alignment data for orienting said handheld tool based upon at least one report received by said positioning infrastructure.

14. The handheld tool of claim 9 further comprising:
a user interface comprising a set of heads-up display (HUD) glasses upon which an image which conveys said desired position and orientation of the working end of said handheld tool.

15. The handheld tool of claim 9 further comprising:
a user interface used to display the location of said structure proximate to said desired position.

16. A system for providing positioning information to handheld tools, said system comprising:
an information management system for accessing task data for a site;
a handheld tool comprising:
a user interface integrated with said handheld tool; and
a tool position detector configured to determine a position of a working end of said handheld tool and an orientation of said handheld tool; and
a positioning infrastructure wirelessly coupled with said information management system and configured to correlate the task data with said position of said working end of said handheld tool and to generate at least one cue for positioning said working end of said

handheld tool at a desired position of said site and to generate at least one cue for orienting said handheld tool at said desired position to a desired orientation wherein the desired orientation is different than a current orientation of said handheld tool, wherein the 5
desired position is different than a current position of said handheld tool, and wherein said user interface is configured to display, on said handheld tool, at least one cue for positioning a working end of said handheld tool at said desired position of said site and said at least 10
one cue for orienting said handheld tool at said desired position to said desired orientation.

17. The system of claim **16** wherein said user interface further comprises a set of heads-up display (HUD) glasses upon which an image which conveys said desired position 15
and orientation of said working end of said handheld tool.

18. The system of claim **16** wherein said positioning infrastructure comprises a device separate from said handheld tool.

19. The system of claim **16** further comprising: 20
a reporting source comprising a wireless transmitter and configured to report task data generated by said handheld tool to said information management system.

* * * * *