



US009648444B2

(12) **United States Patent**
Agee

(10) **Patent No.:** **US 9,648,444 B2**
(45) **Date of Patent:** **May 9, 2017**

(54) **PHYSICALLY SECURE DIGITAL SIGNAL PROCESSING FOR WIRELESS M2M NETWORKS**

FOREIGN PATENT DOCUMENTS

GB 2491835 12/2012
GB 2491836 A 12/2012

(Continued)

(71) Applicant: **Brian G. Agee**, San Jose, CA (US)

(72) Inventor: **Brian G. Agee**, San Jose, CA (US)

(*) Notice: Subject to any disclaimer, the term of this patent is extended or adjusted under 35 U.S.C. 154(b) by 169 days.

Agarwal, M. et al.; Optimal Bandwidth Allocation to Coding and Spreading in DS-CDMA Systems Using LMMSE Front-End Detector; IEEE Trans. on Wireless Comm., V.4 N6; Nov. 2005, p. 2636-41.

(Continued)

(21) Appl. No.: **13/999,040**

(22) Filed: **Jan. 6, 2014**

(65) **Prior Publication Data**

US 2015/0195670 A1 Jul. 9, 2015

(51) **Int. Cl.**

H04B 1/00 (2006.01)

H04W 4/00 (2009.01)

H04B 1/715 (2011.01)

(52) **U.S. Cl.**

CPC **H04W 4/005** (2013.01); **H04B 2001/7154** (2013.01)

(58) **Field of Classification Search**

CPC H04W 4/005; H04B 1/7103; H04B 1/715; H04B 1/7156

USPC 375/133, 144

See application file for complete search history.

(56) **References Cited**

U.S. PATENT DOCUMENTS

5,260,968 A 11/1993 Gardner et al.
5,343,496 A 8/1994 Honig et al.
5,692,006 A * 11/1997 Ross H04B 1/7097
375/147

5,848,105 A 12/1998 Gardner
6,175,587 B1 1/2001 Madhow et al.

(Continued)

OTHER PUBLICATIONS

Primary Examiner — Helene Tayong

(74) *Attorney, Agent, or Firm* — George S. Cole

(57)

ABSTRACT

A method and apparatus for physically secure communication over machine-to-machine (M2M) networks is claimed, through the use of frequency-hop and random access spread spectrum modulation formats employing using truly random spreading codes and time/frequency hopping and receiver selection strategies at the transmitters in the M2M network, blind signal detection and linear signal separation techniques at the receivers in the M2M network, completely eliminating the ability for an adversary to predict and override M2M transmissions. Additional physical security protocols are also introduced that allow the network to easily detect and identify spoofing transmissions on uplinks and downlinks, and to automatically excise those transmissions as part of the despreading procedure, even if those transmissions are received at a much higher power level than the intended transmissions. Extensions to weakly and strongly macrodiverse networks are also described, which provide additional efficiency and security improvements by exploiting the route diversity of the network.

34 Claims, 37 Drawing Sheets

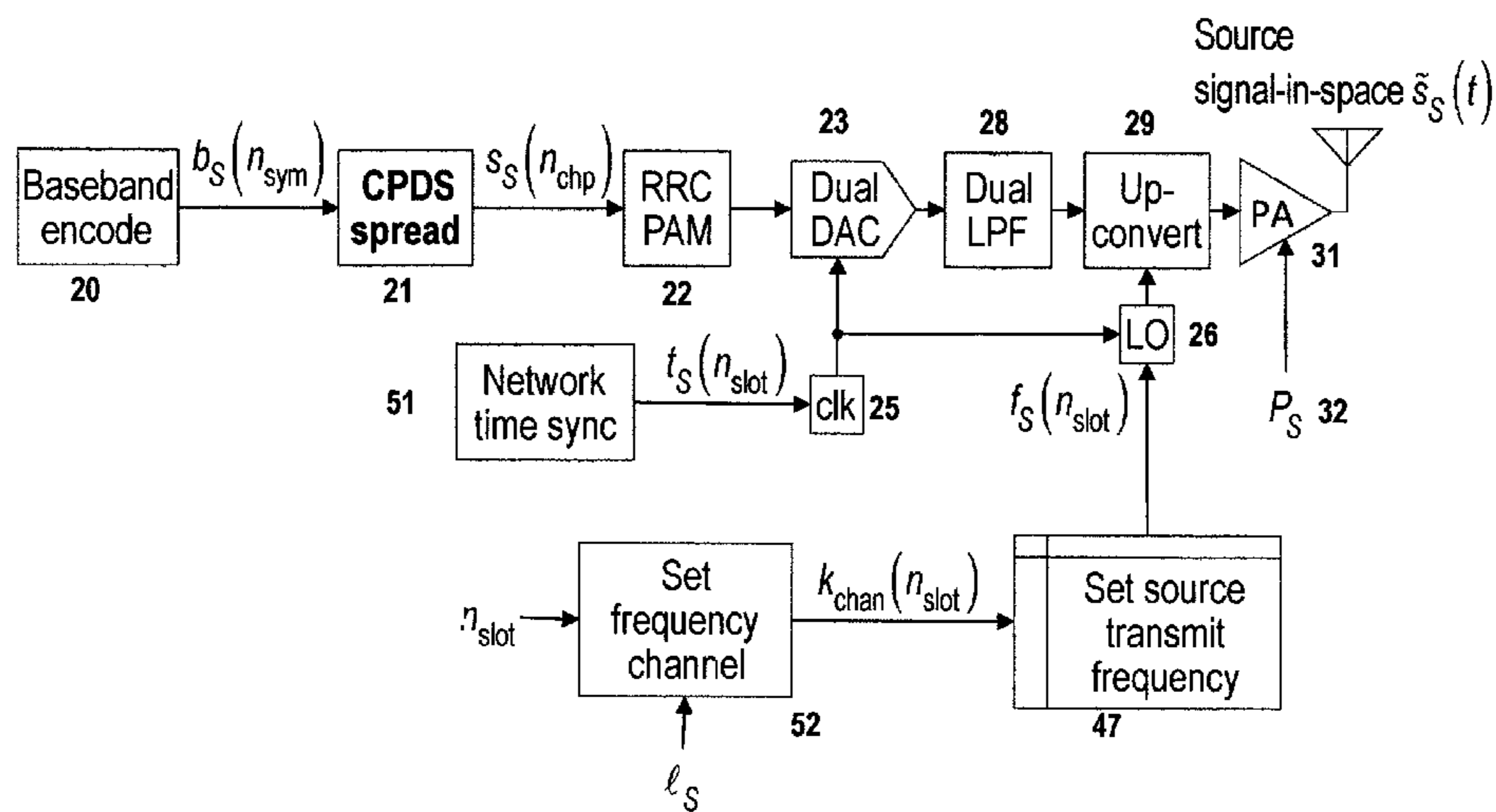

(56)

References Cited

U.S. PATENT DOCUMENTS

6,175,588	B1	1/2001	Visotsky et al.	
6,426,973	B1	7/2002	Madhow et al.	
6,621,851	B1	9/2003	Agee et al.	
6,658,047	B1	12/2003	Komulainen et al.	
6,771,690	B2	8/2004	Heikkila	
6,975,666	B2	12/2005	Affes et al.	
7,050,490	B2	5/2006	Chi et al.	
7,079,480	B2	7/2006	Agee	
7,099,372	B2	8/2006	Nieczyporowicz et al.	
7,126,982	B1	10/2006	Barham et al.	
7,130,333	B2	10/2006	Gibson, Jr. et al.	
7,161,927	B2	1/2007	Wu et al.	
7,248,841	B2	7/2007	Agee et al.	
7,301,985	B1	11/2007	Hall et al.	
7,313,164	B1	12/2007	Wilson et al.	
7,321,564	B2	1/2008	Ikram et al.	
7,336,930	B2	2/2008	Larsson et al.	
7,443,909	B2	10/2008	Nguyen et al.	
7,453,855	B1	11/2008	Madhow	
7,483,480	B2	1/2009	Guo et al.	
7,492,815	B2	2/2009	Guo et al.	
7,539,239	B2	5/2009	Barham et al.	
1,106,477	A1	4/2010	Larsson	
7,701,999	B1	4/2010	Schlegel et al.	
7,764,747	B2	7/2010	Ionescu	
7,768,990	B1	8/2010	Schlegel et al.	
7,978,747	B1	7/2011	Harris et al.	
8,036,255	B1	10/2011	Harris et al.	
8,036,601	B2	10/2011	Prasad et al.	
8,059,610	B2	11/2011	Li et al.	
8,130,693	B2	3/2012	Miller et al.	
8,144,668	B1	3/2012	Madhow	
8,290,074	B2	10/2012	Annavajjala et al.	
8,345,693	B1	1/2013	Kim	
8,345,733	B2	1/2013	Ghosh	
8,412,129	B2*	4/2013	Himayat et al.	455/101
2008/0291972	A1*	11/2008	Chin Po Shin et al.	375/130
2011/0270984	A1*	11/2011	Park	709/225
2012/0230178	A1*	9/2012	Wang et al.	370/216
2012/0231828	A1*	9/2012	Wang et al.	455/509
2014/0056221	A1*	2/2014	Li et al.	370/328

FOREIGN PATENT DOCUMENTS

GB	2491840	A	12/2012
WO	WO 2012/171867	A1	12/2012

OTHER PUBLICATIONS

Comaniciu, C. et al.; Capacity Regions and Optimal Power Allocation for Groupwise Multiuser Detection; IEEE Trans. on Wireless Comm., V 4 N 2; Mar. 2005; p. 349-352.

Shi, Z. et al.; On the Performance of Partitioned-Spreading CDMA with Multistage Demodulation; 1-4244-0350-2/06/\$20.00 © 2006 IEEE, p. 1522-1527.

Comaniciu, C. et al.; Jointly Optimal Power and Admission Control for Delay Sensitive Traffic in CDMA Networks with LMMSE Receivers; IEEE Trans. Sig Proc.; V51 N8 Aug. 2003; 2031-42.

Etkin, R. et al.; Degrees of Freedom in Underspread MIMO Fading Channels; ISIT 2003; 0-7803-7728-1/03/\$17.00 © 2003 IEEE; p. 323.

Kempton, Roland; Capacity and QoS Analysis for a Novel Packet Based Wireless Access System; 0-7803-7954-3/03/\$17.00 © 2003 IEEE; p. 1432-1436.

Veeravalli, V. et al.; The Coding-Spreading Tradeoff in CDMA Systems; IEEE Journal on Selected Areas in Communications, V. 20, No. 2, Feb. 2002; p. 396-408.

Mirbagheri, A. et al.; A Linear MMSE Receiver for Multipath Asynchronous Random-Shaping CDMA With Chip Pulse Shaping; IEEE Trans. on Vehic. Tech., V51 N5 Sep. 2002; p. 1072-1086.

Zaidel, M. et al.; Multicell Uplink Spectral Efficiency of Coded DS-SS With Random Signatures; IEEE Journal on Selected Areas in Commun., V19, N8, Aug. 2001; p. 1556-1569.

Evans, J. et al.; Large System Performance of Linear Multiuser Receivers in Multipath Fading Channels; IEEE Trans. on Information Theory, V46, N6, Sep. 2000; p. 2059-2078.

William Webb; Understanding Weightless: Technology, Equipment, and Network Deployment for M2M Communications in White Space; 2012; p. 15; Camb. U. Press; ISBN 978-1-107-02707-7. www.weightless.org.

Ali Tajer et al.; Coordination Limits in MIMO Networks; 2011 IEEE Symposium on Information Theory Proceedings; pp. 933-937.

Kammoun, Abla et al.; A Central Limit Theorem for the SINR at the LMMSE Estimator Output for Large-Dimensional Signals; IEEE Trans. on Inf. Theory, V 55 N 11 Nov. 2009; 5048-5063.

Hemabih Shekhar et al.; On the Use of LMMSE Receiver for Single and-Multiple Packet Reception in Stabilized Multi-Channel Slotted Aloha; 1-4244-1463-6/08/ © 2008 IEEE p. 215-218.

Hemabih Shekhar et al.; Closed Form Throughput of a Slotted ALOHA Network Using LMMSE Receiver; 978-1-4244-2110-7/08/ (c) 2007 IEEE p. 2128-2132.

Ng, B. L. et al.; On the Capacity of Cellular Networks with Global LMMSE Receiver; 1-4244-0353-7/07/\$25.00 © 2007 IEEE; p. 870-876.

Ioannis D. Schizas et al.; Consensus-Based Distributed Estimation of Random Signals with Wireless Sensor Networks; 1424407850/06/ p. 530-534.

Schlegel, C. et al.; A Novel Random Wireless Packet Multiple Access Method Using CDMA; IEEE Transactions on Wireless Communications, vol. 5, No. 6, Jun. 2006 p. 1362-1370.

Montanari, A.; Analysis of Belief Propagation for Non-Linear Problems; 2006 IEEE Information Theory Workshop; 1-4244-0036-8/06/ © C2006 IEEE; p. 160-164.

Tse, D. N. C. et al.; Linear Multiuser Receivers: Effective Interference, Effective Bandwidth and User Capacity; IEEE Trans. on Information Theory; V45 N2, Mar. 1999; p. 641-657.

Verdu, S. et al.; Spectral Efficiency of CDMA with Random Spreading; IEEE Transactions on Information Theory, vol. 45, No. 2, Mar. 1999; p. 622-640.

Wang, X. et al.; Blind Multiuser Detection: A Subspace Approach; IEEE Transactions on Information Theory, vol. 44, No. 2, Mar. 1998; p. 677-690.

Morrow, R. K. Jr. et al.; Packet Throughput in Slotted ALOHA DS/SSMA Radio Systems with Random Signature Sequences; IEEE Trans. on Communications; V40 N7 Jul. 1992; p. 1223-1230.

Agee, B.; The Property Restoral Approach to Blind Adaptive Signal Extraction, Ph.D Dissertation, Dept. of Electrical Engineering, U. of Cal. Davis, CA Jun. 1989.

Agee, B. et al.; Spectral Self-Coherence Restoral: A New Approach to Blind Adaptive Signal Extraction Using Antenna Arrays; IEEE Proceedings, V78 N4, Apr. 1990, p. 753-767.

Agee, B.; Maximum-Likelihood Approaches to Blind Adaptive Signal Extraction Using Narrowband Antenna Arrays; Proc. 25th Asilomar Conf. on Sign., Svs. Comp.; V2 Nov. 1991; p. 716-720.

* cited by examiner

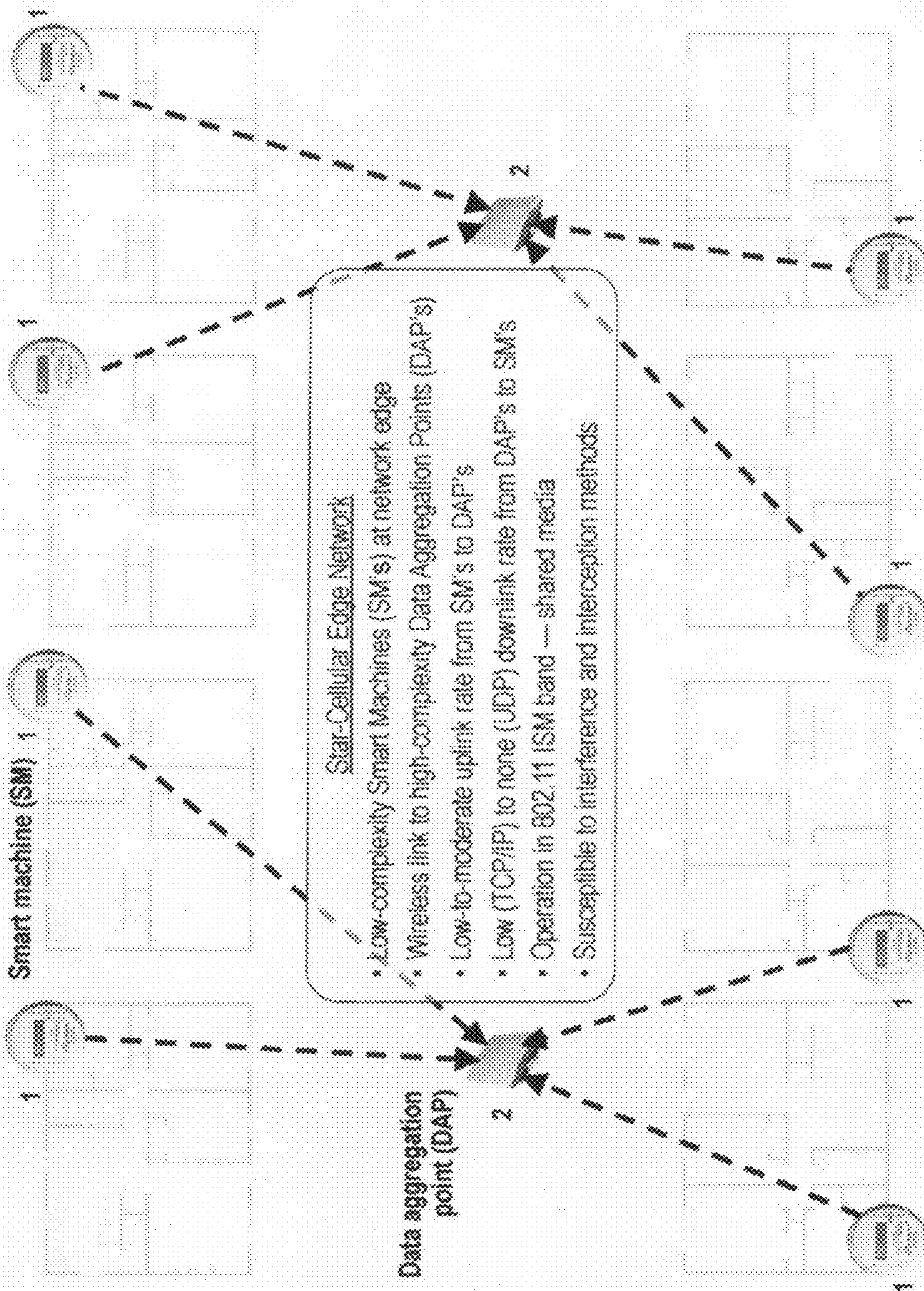

Figure 1

Physically Secure Digital Signal Processing For Wireless M2M Networks; S/N 13/959,040; Inventor: Ages, B. G.; Corrected

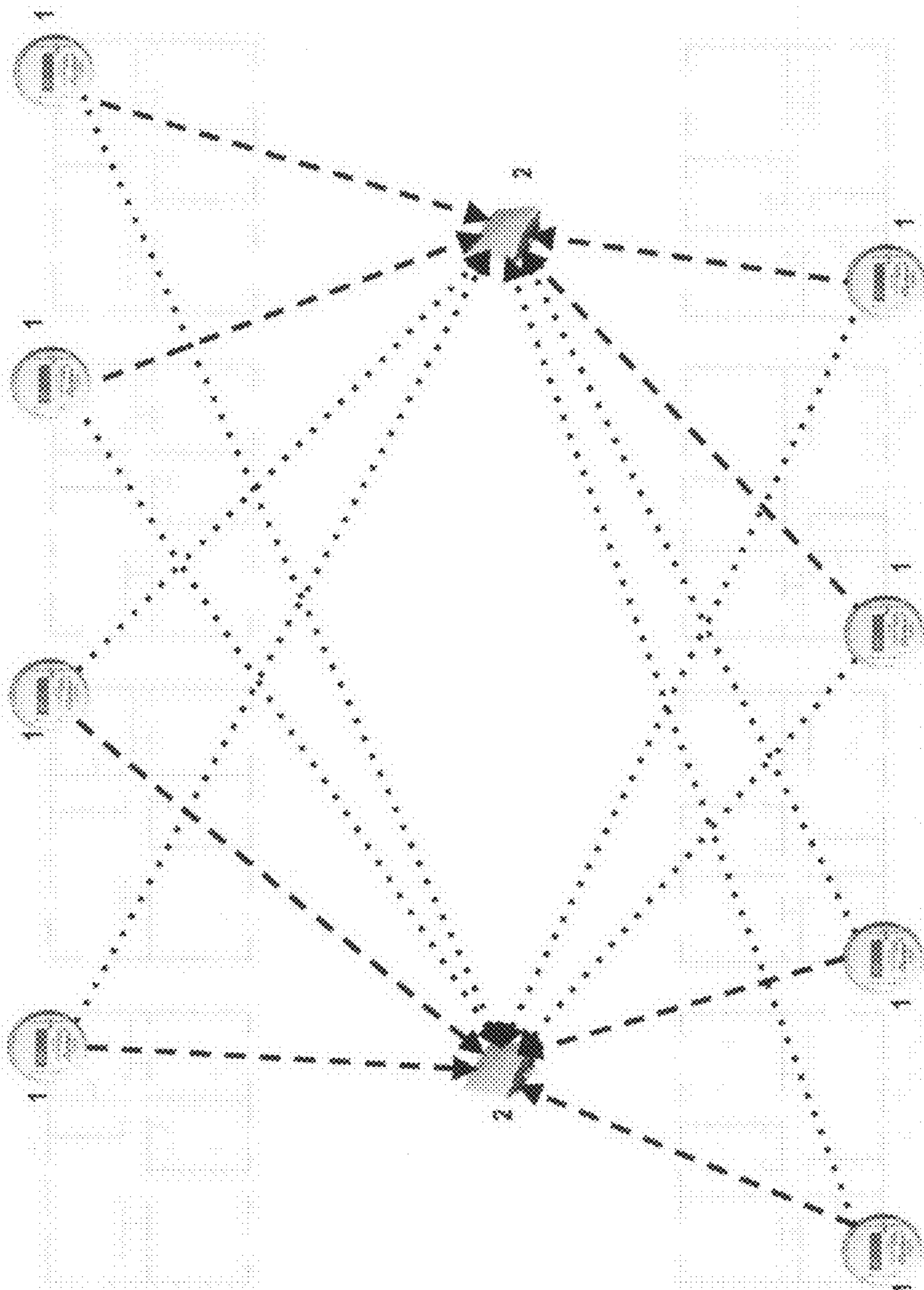

Figure 2

Physically Secure Digital Signal Processing For Wireless M2M Networks, S/N 13/939,040, Inventor, Agsee, B. G.; Corrected

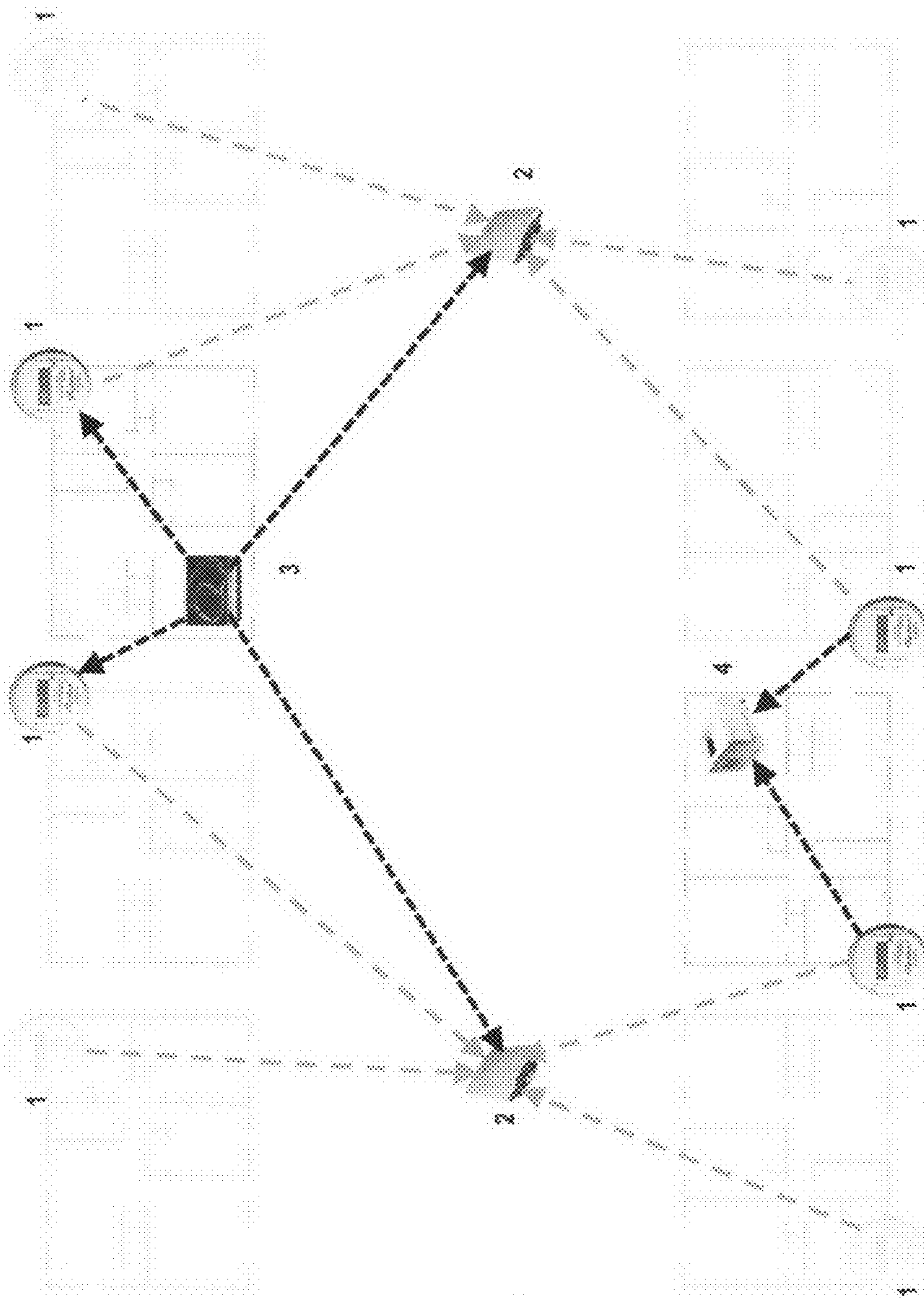

Figure 3

Physically Secure Digital Signal Processing For Wireless M2M Networks: SIN 13/999,040; Inventor: Agsee, B. G.; Corrected

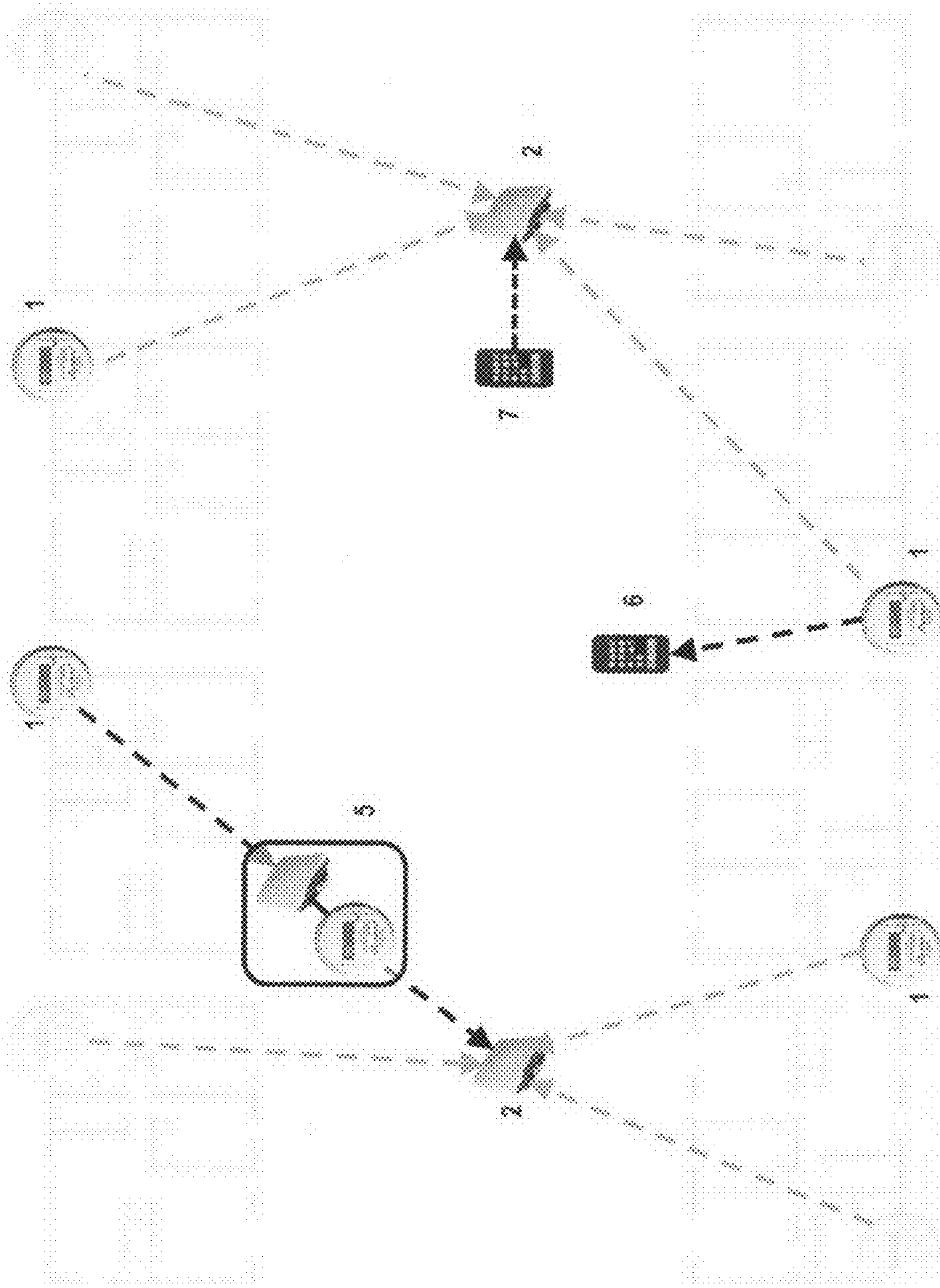
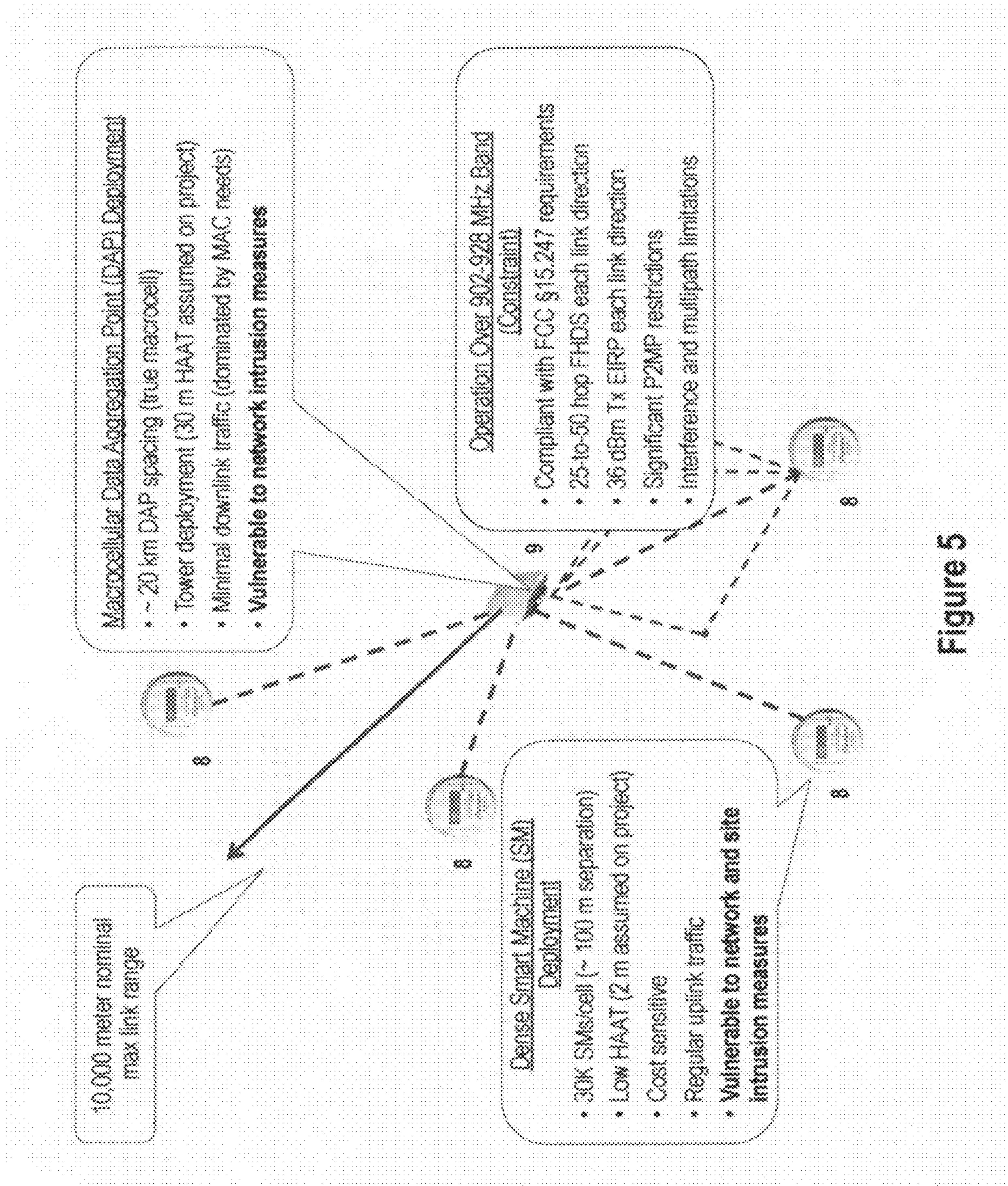

Figure 4



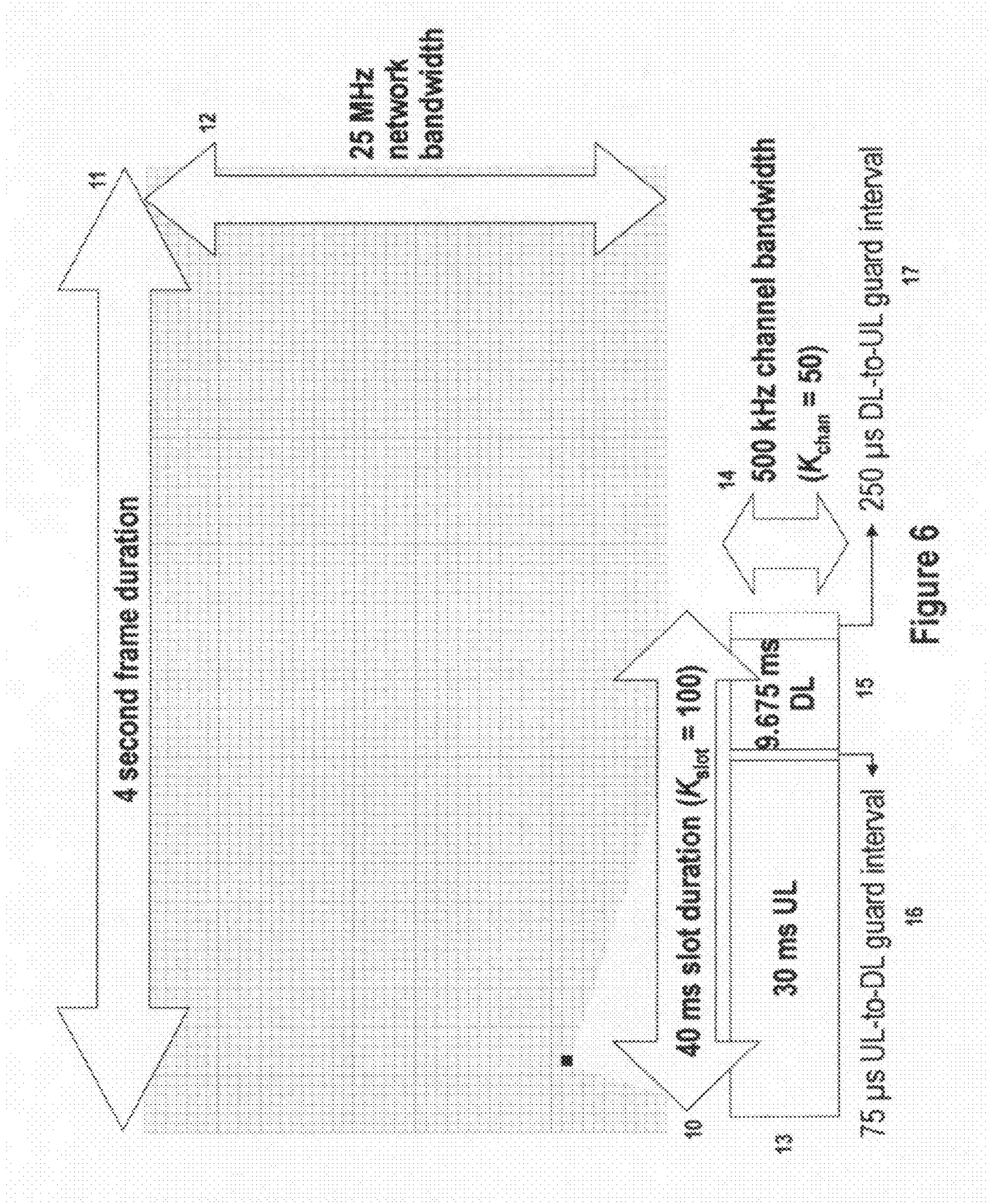

Figure 6

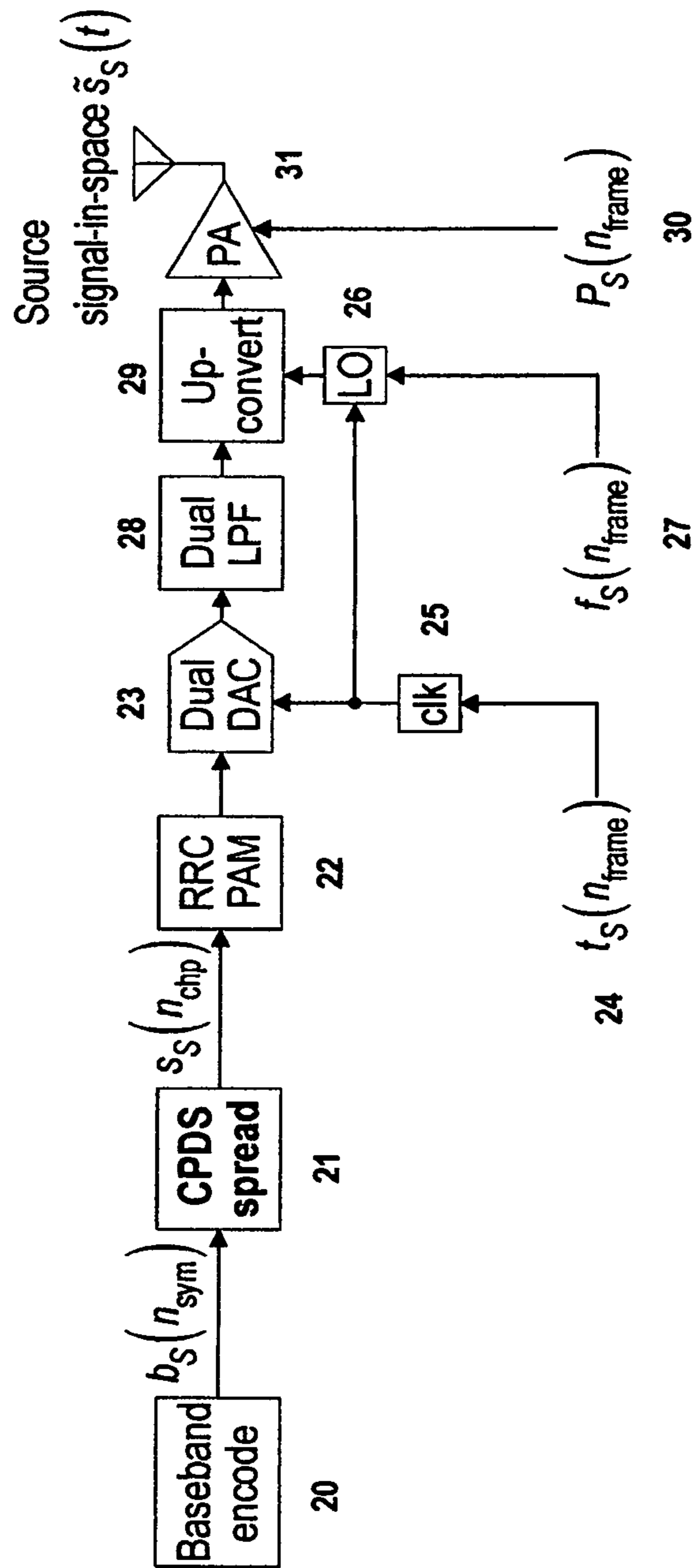

Figure 7

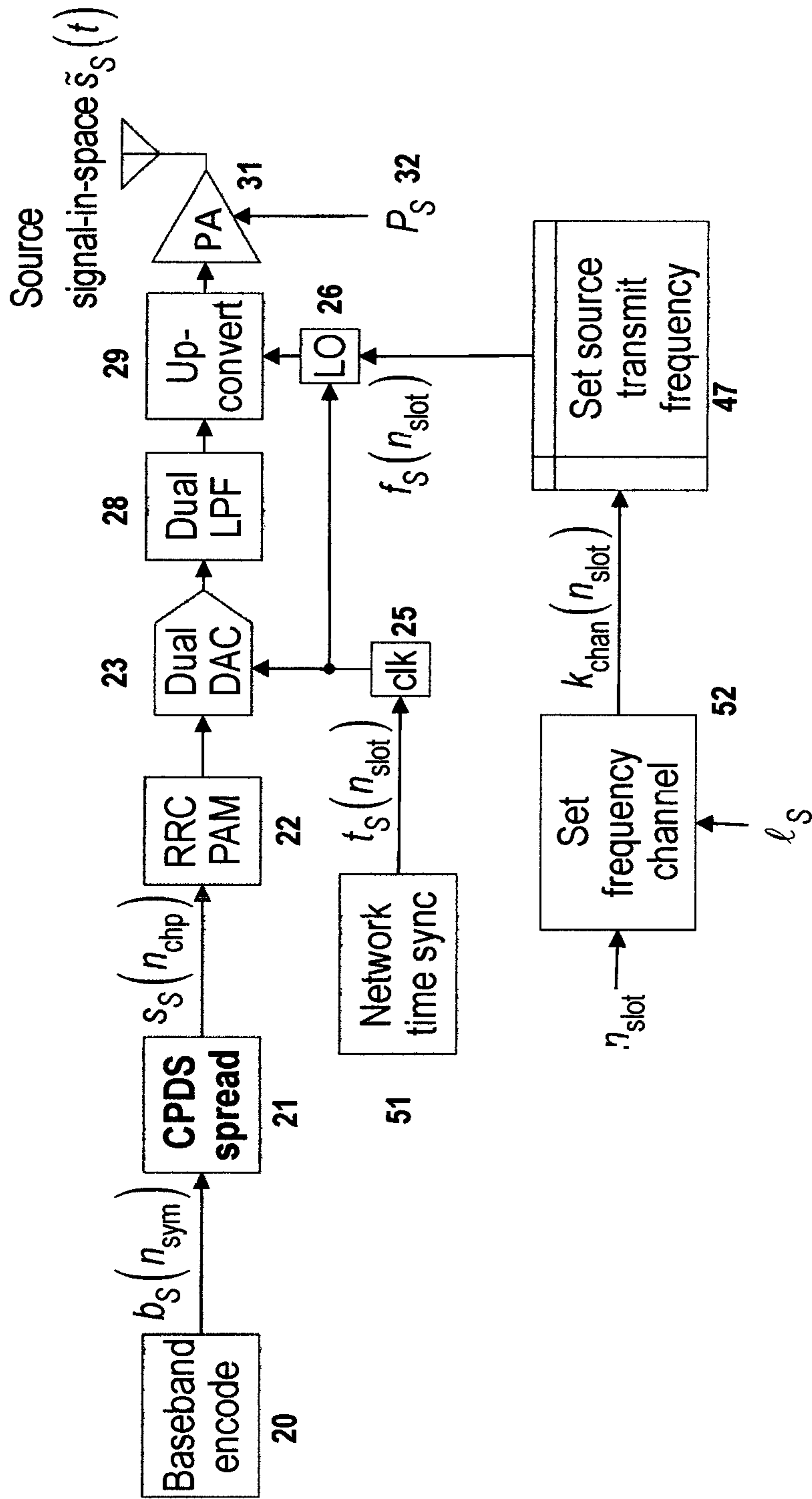

Figure 9

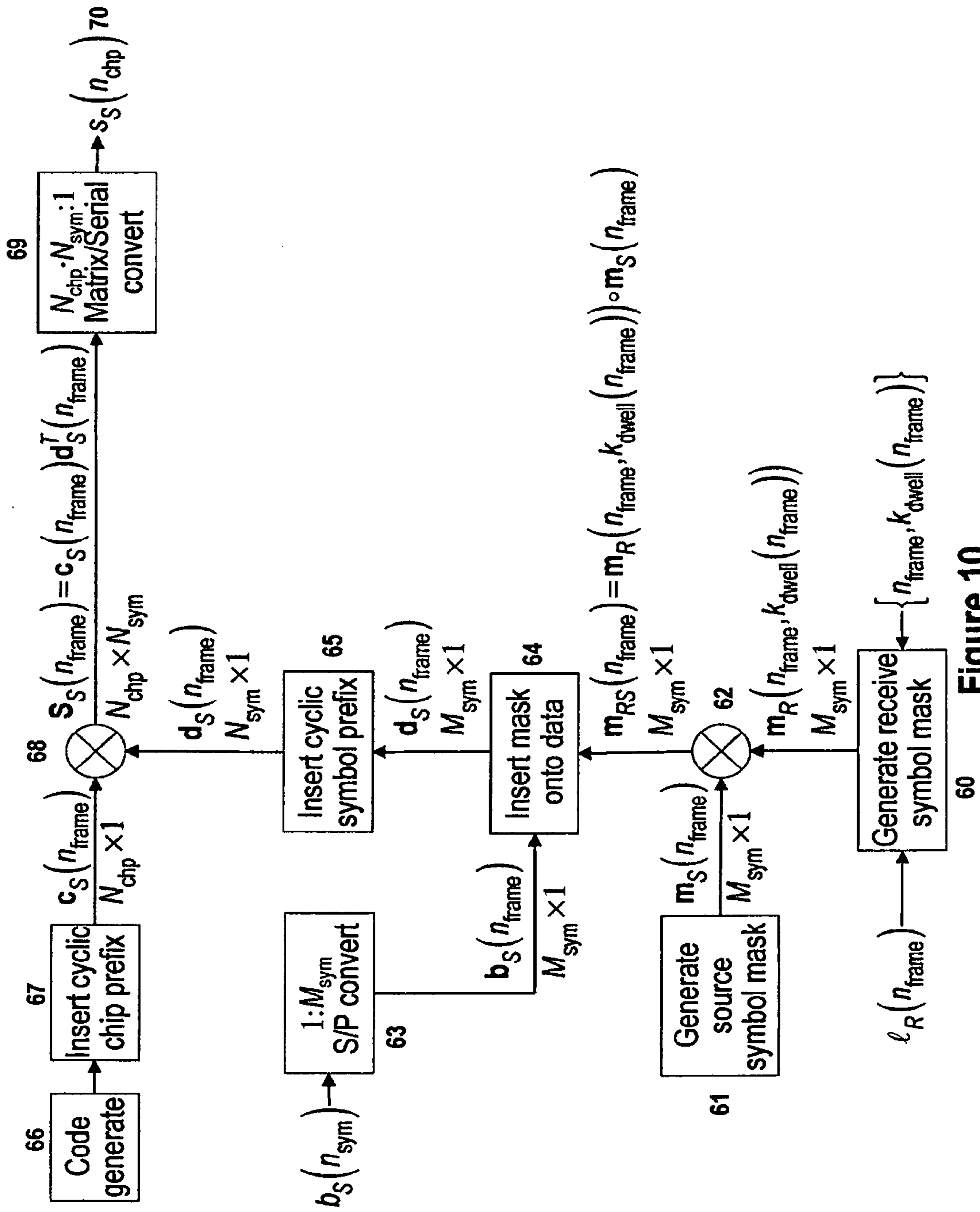

Figure 10

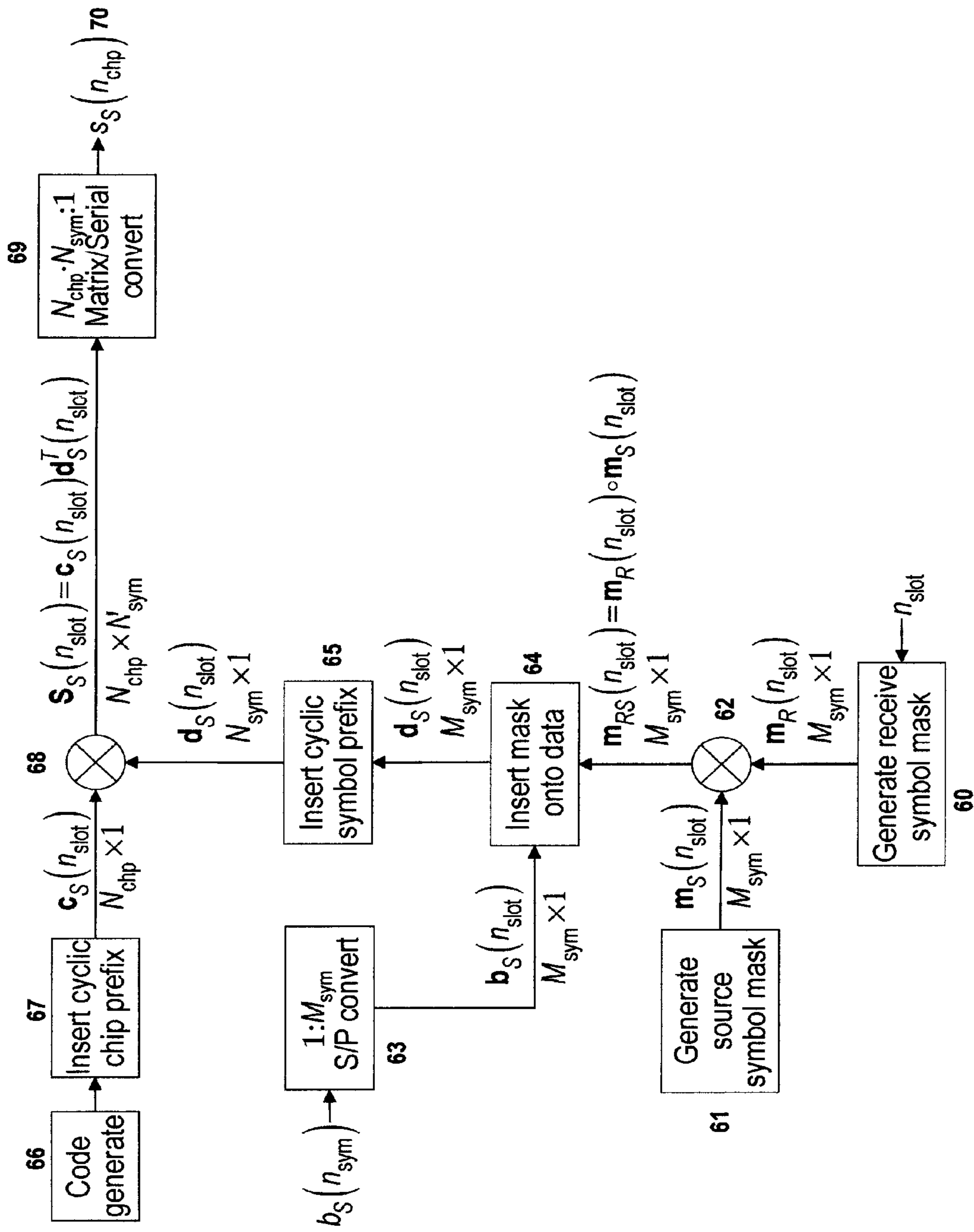

Figure 11

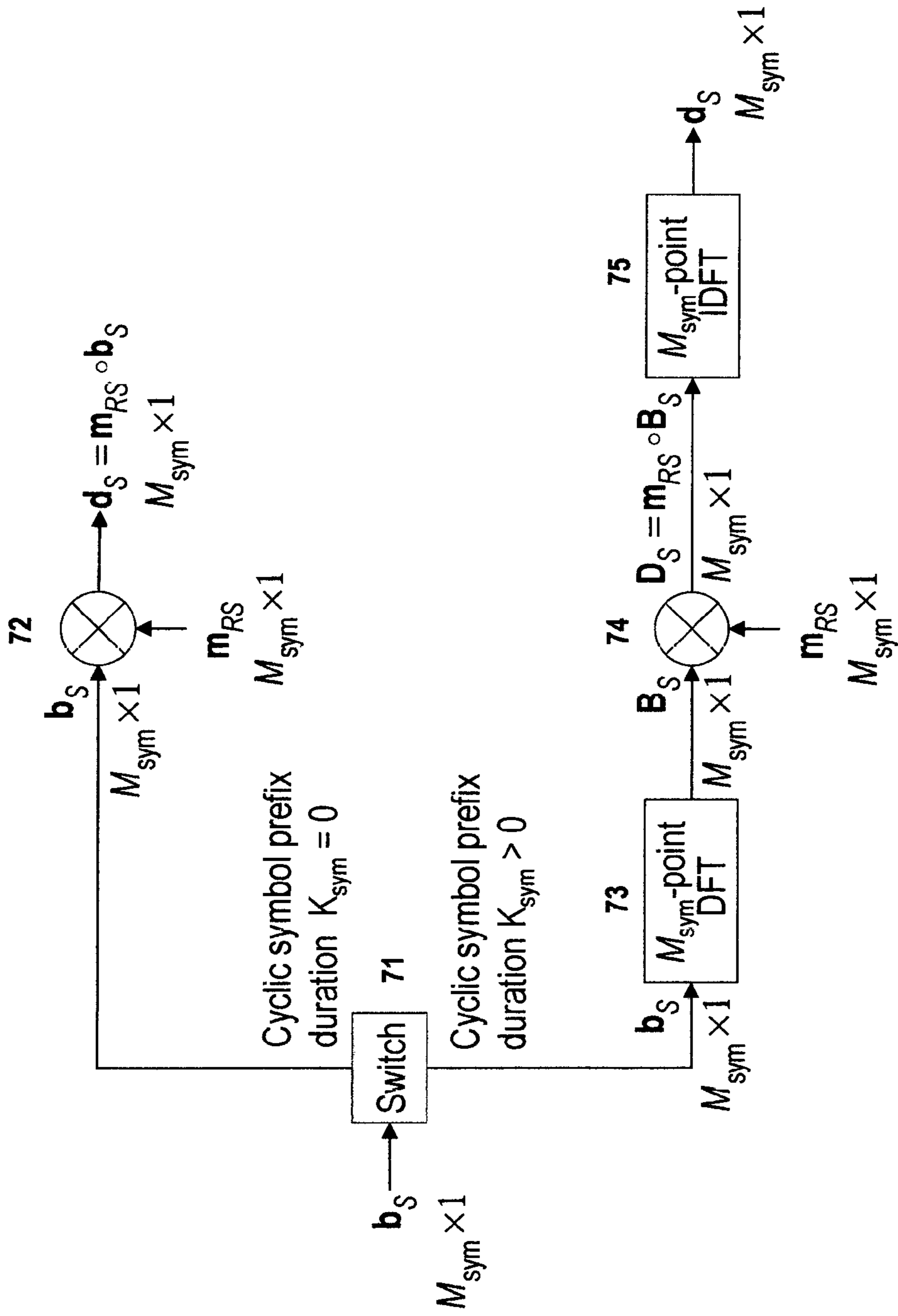

Figure 12

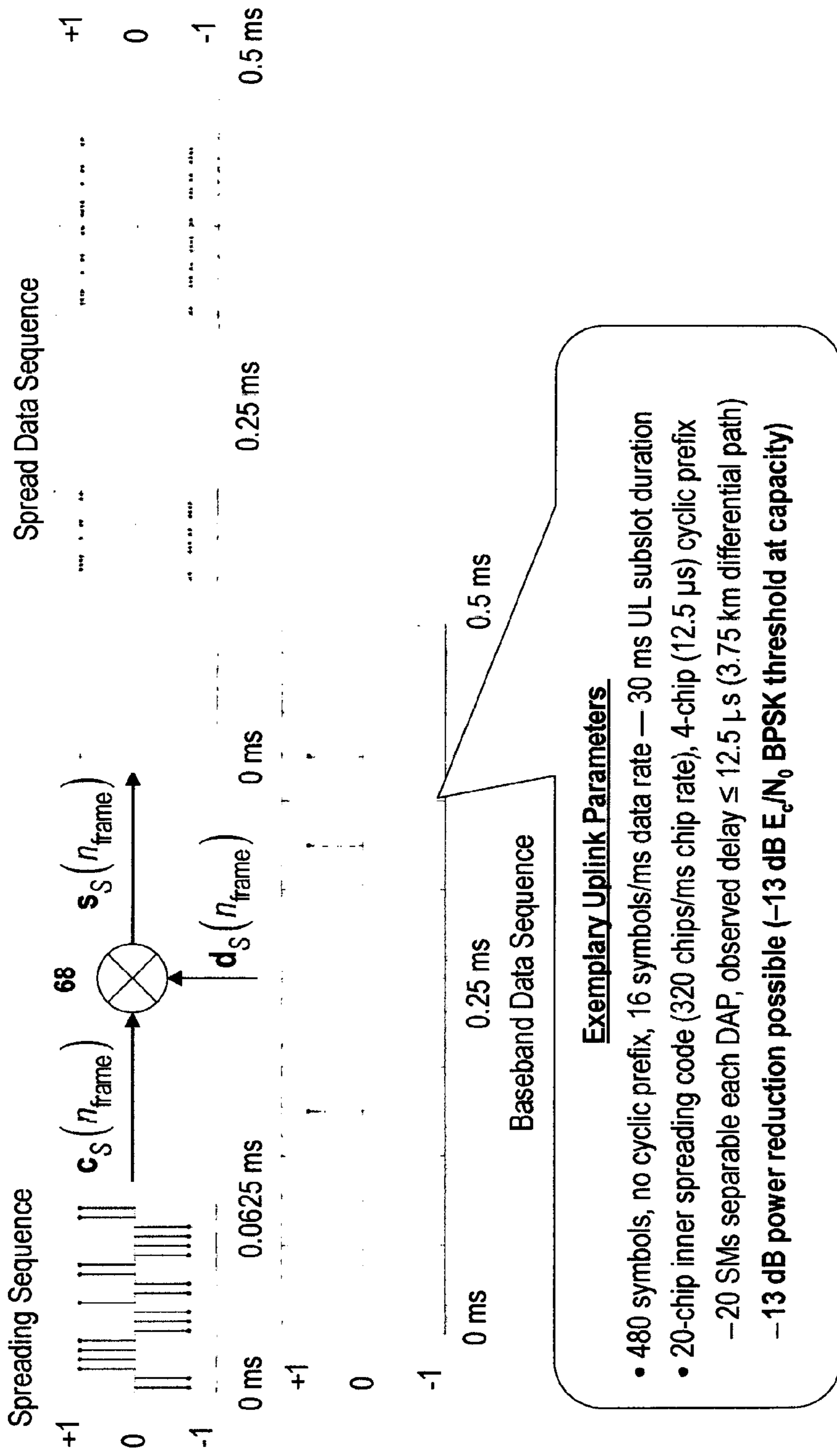
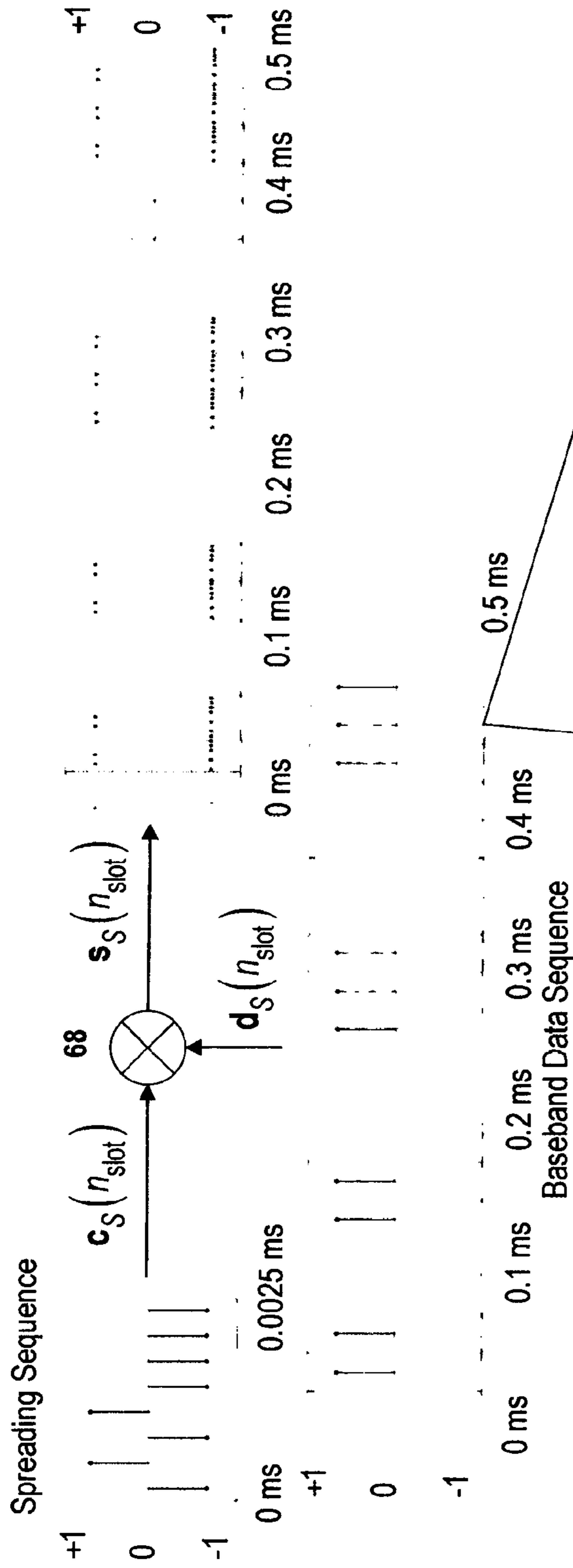

Figure 13



Exemplary CPDS Downlink Parameters

- 384 symbols, 3 symbol (75 μ s) cyclic prefix, 40 symbols/ms data rate—9.675 ms DL subslot duration
- 8-chip inner spreading code (320 chip/ms chip-rate), no cyclic prefix (loading accepted)
 - 4-to-8 DAPs separable each SM using time-channelized despreading
 - 6 dB power reduction possible (–6 dB E_c/N_0 BPSK threshold at capacity)

Figure 14

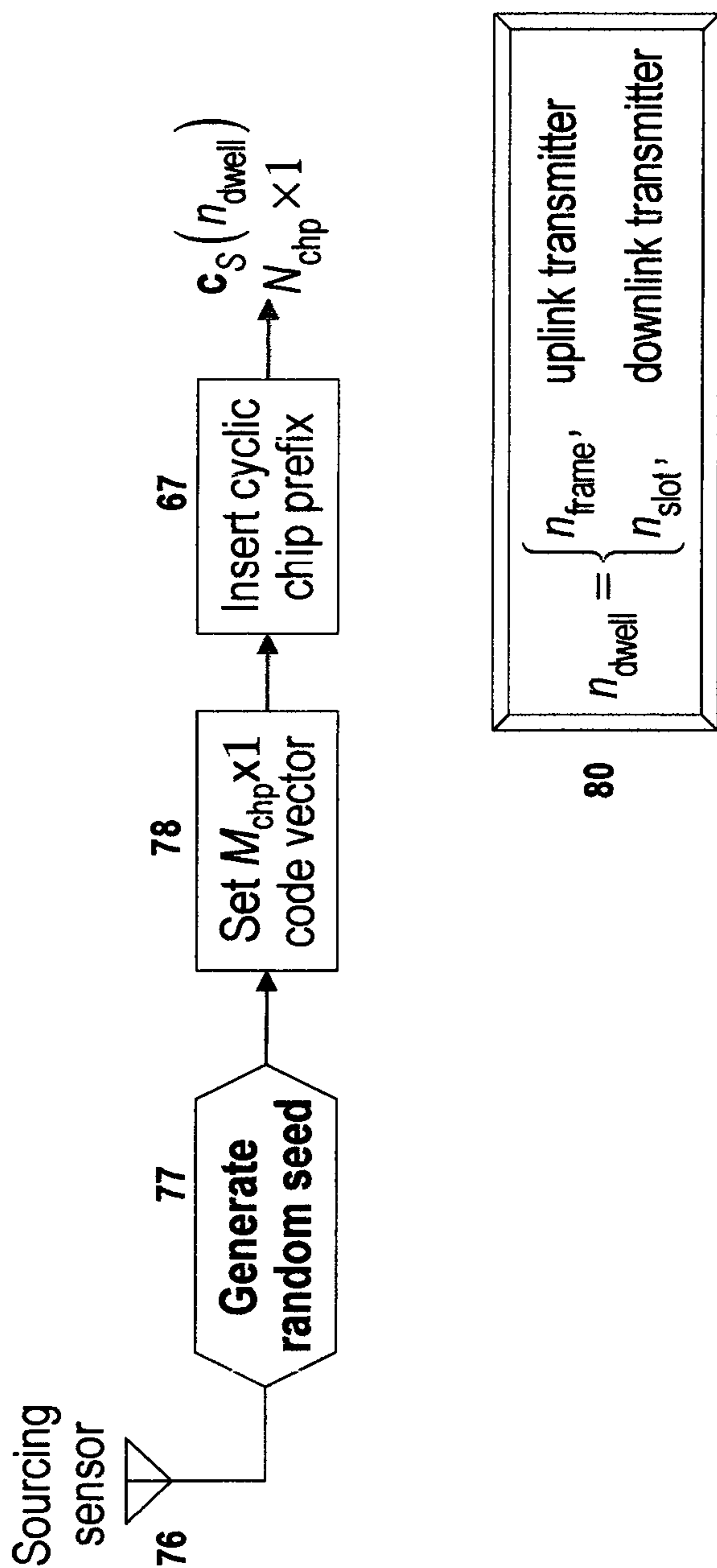

Figure 15

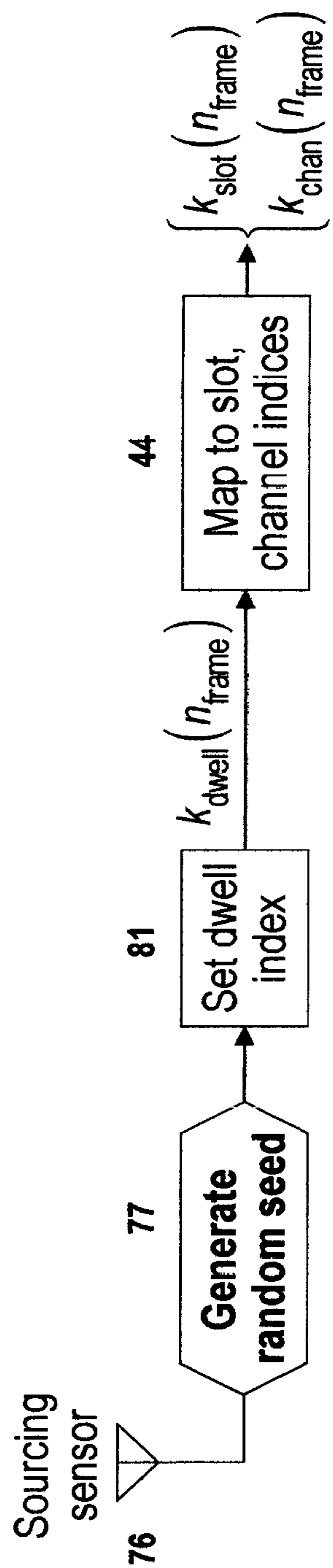

Figure 16

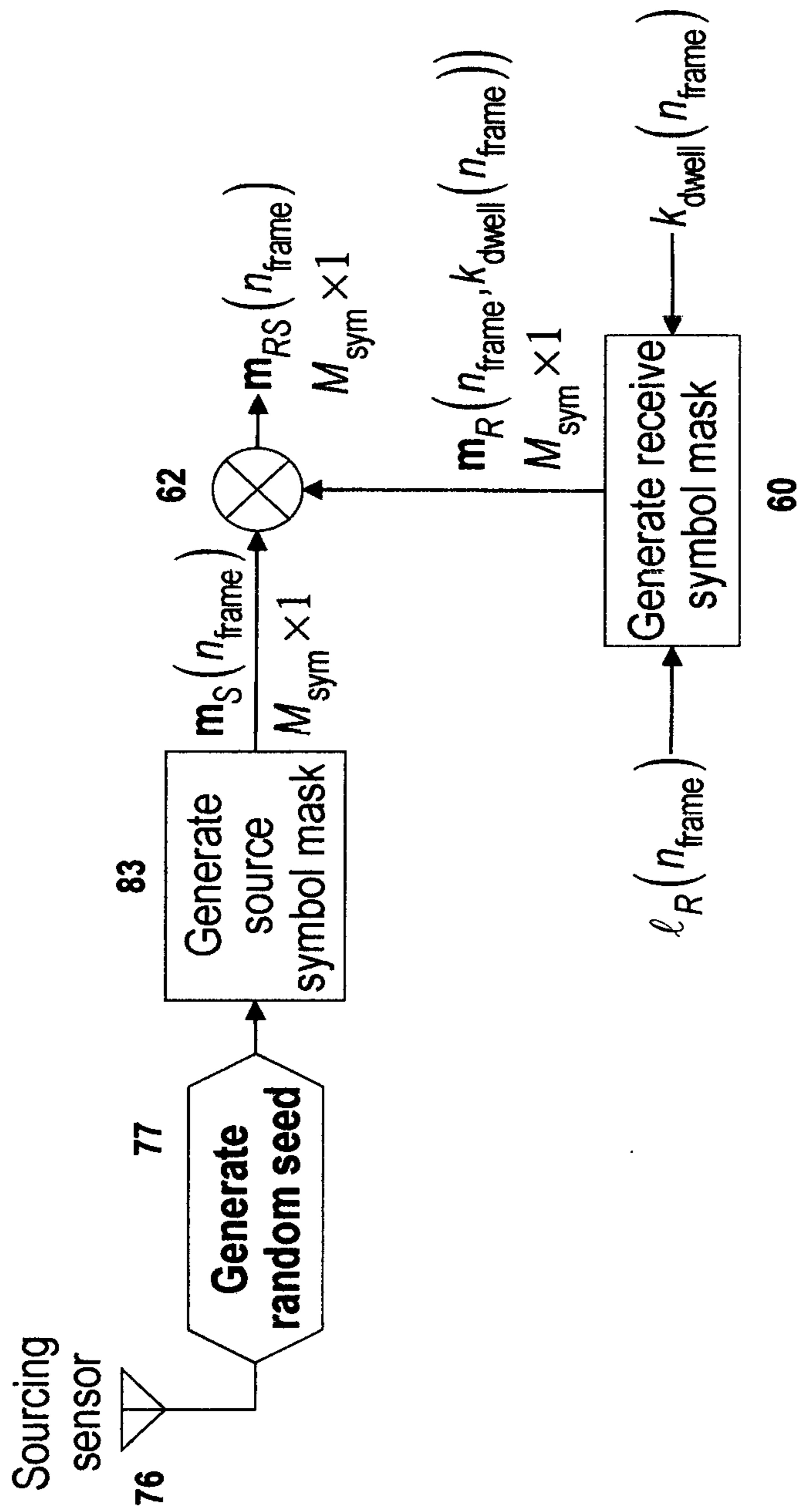

Figure 17

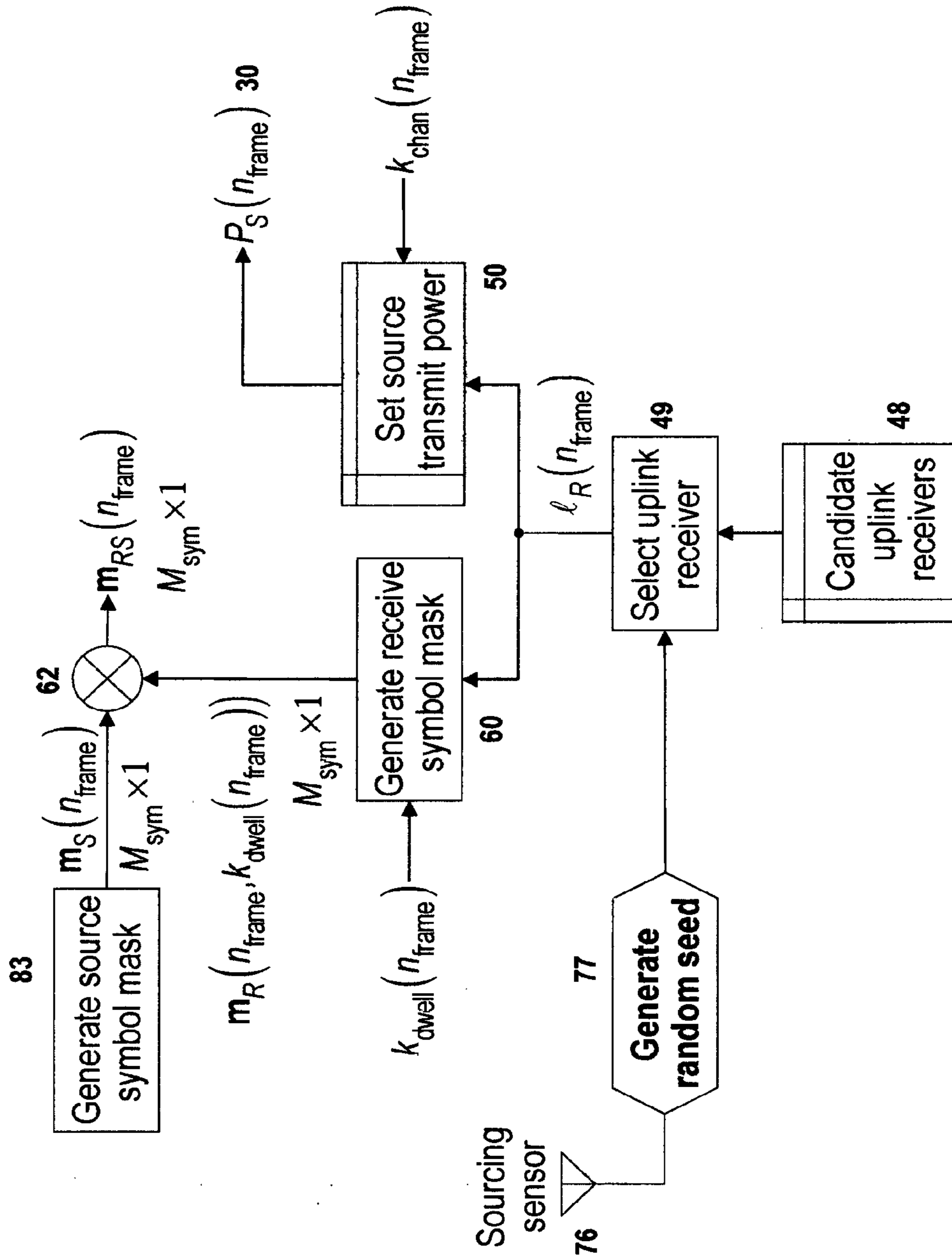

Figure 18

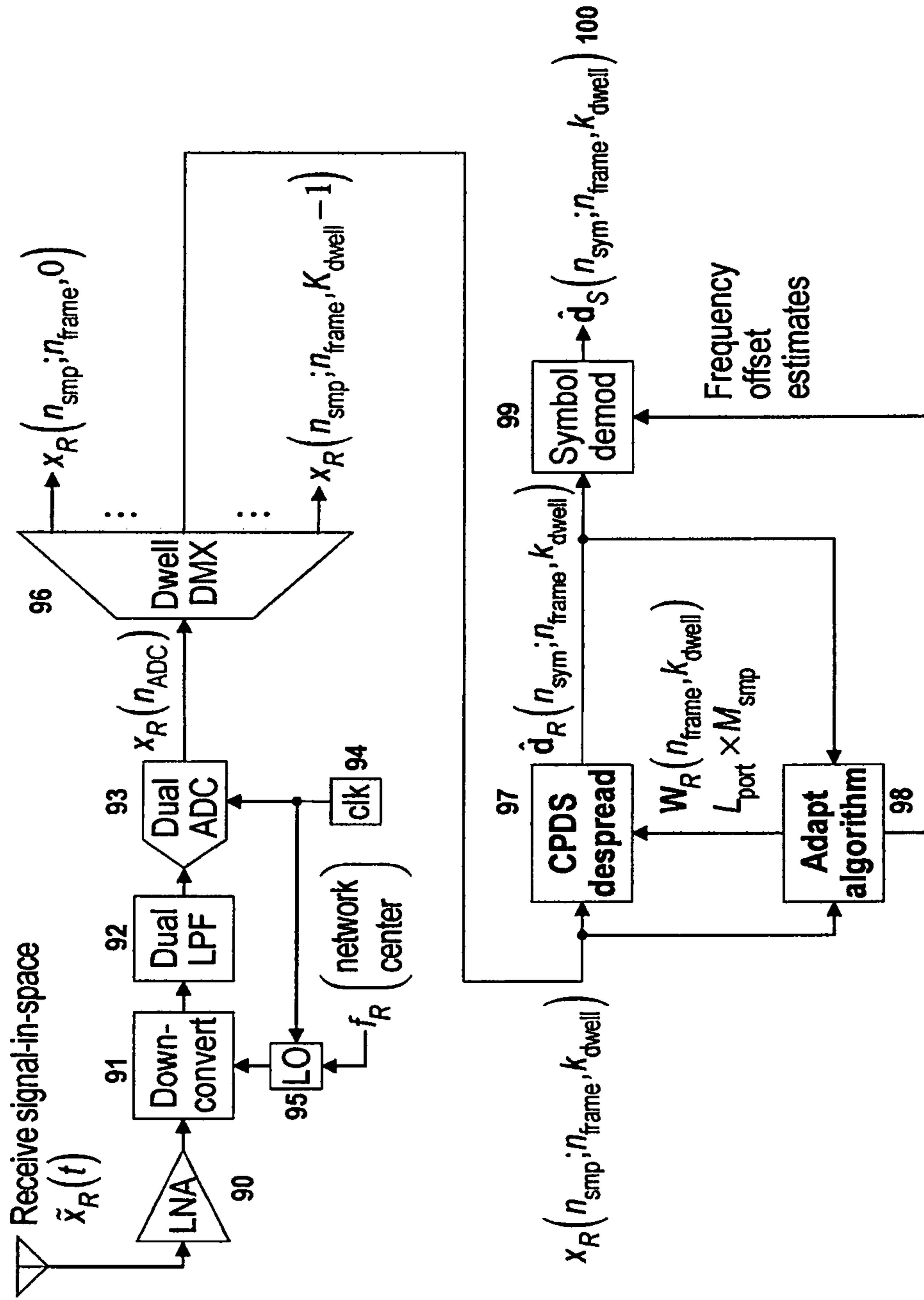

Figure 19

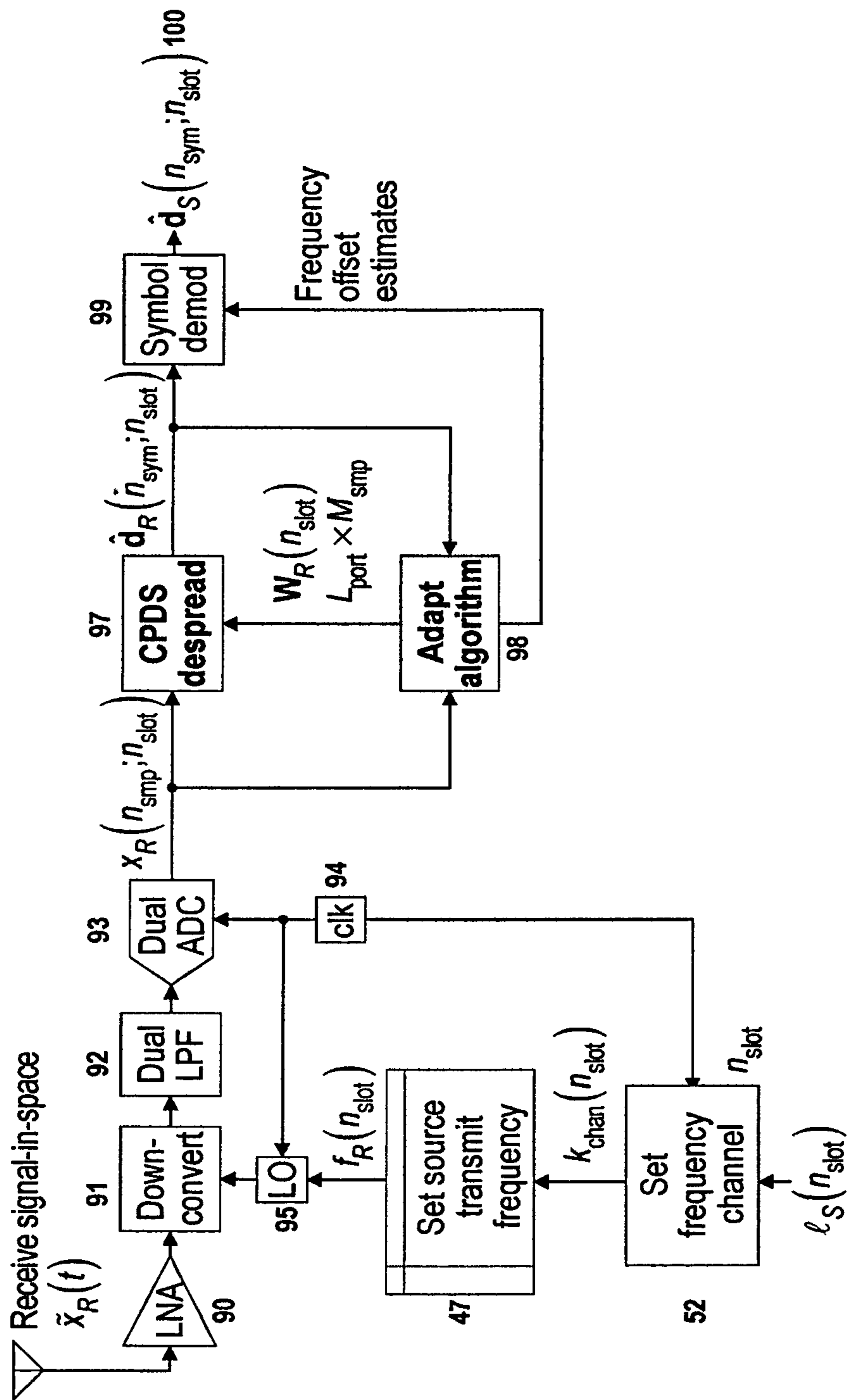

Figure 20

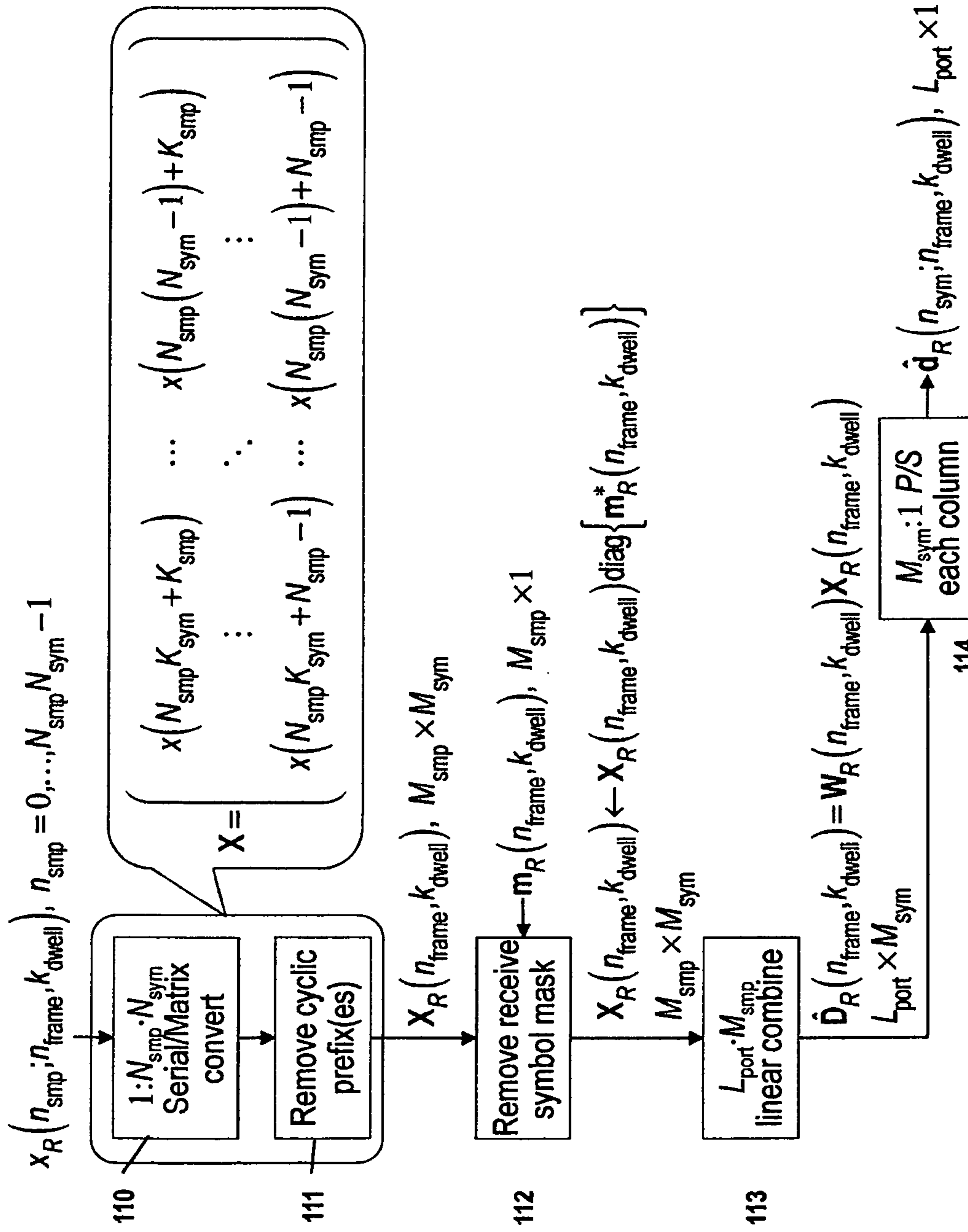

Figure 21

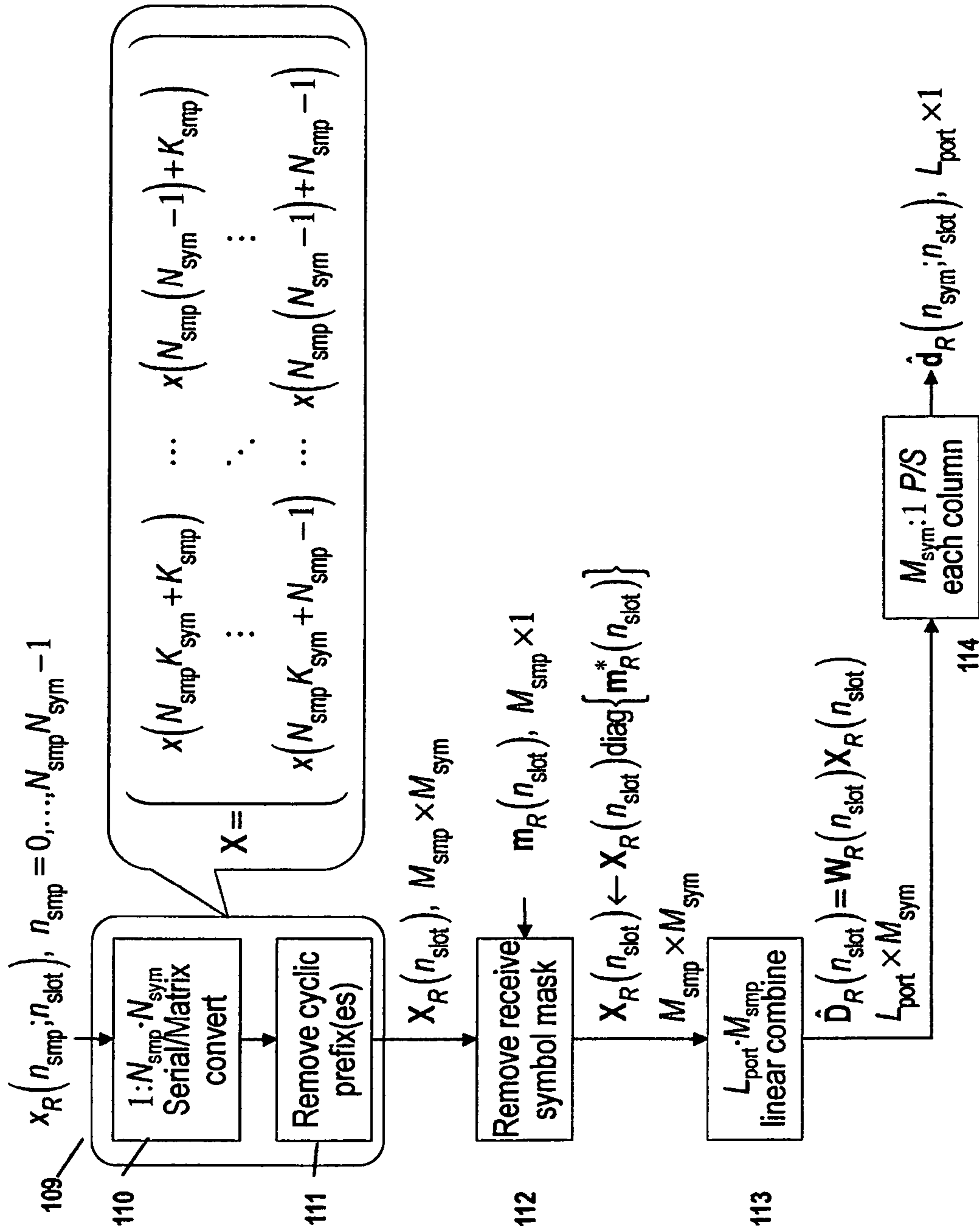
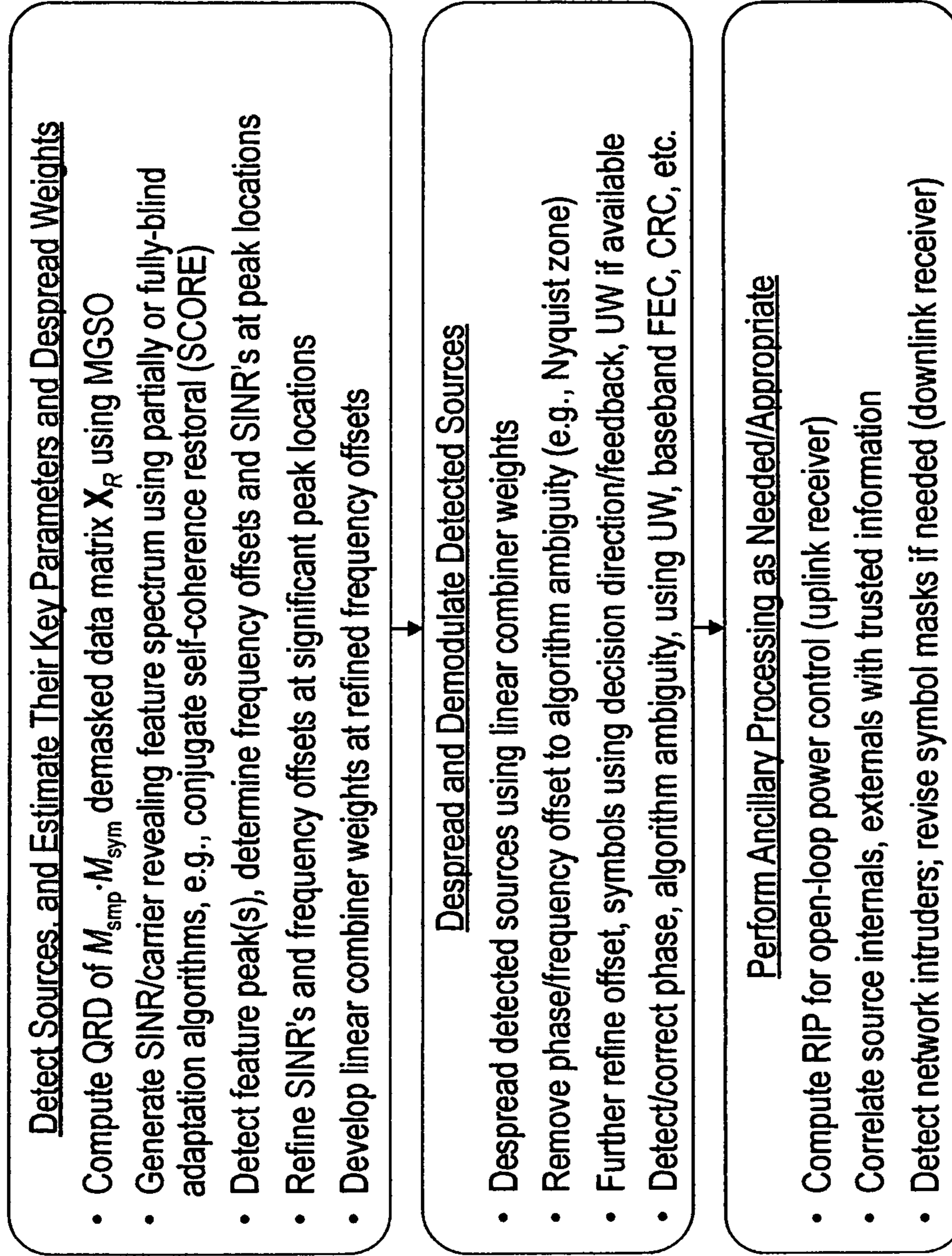

Figure 22

**Figure 23**

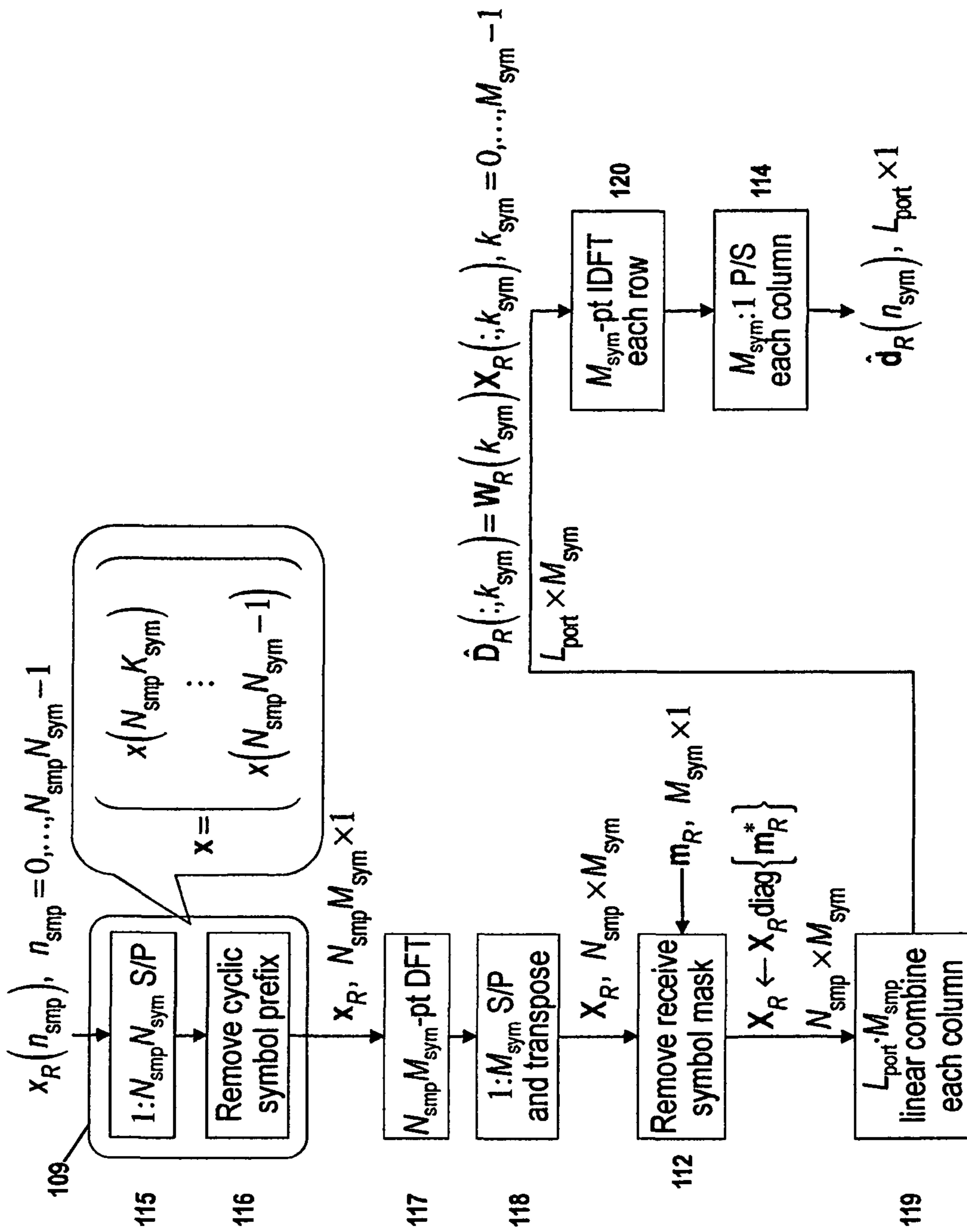

Figure 24

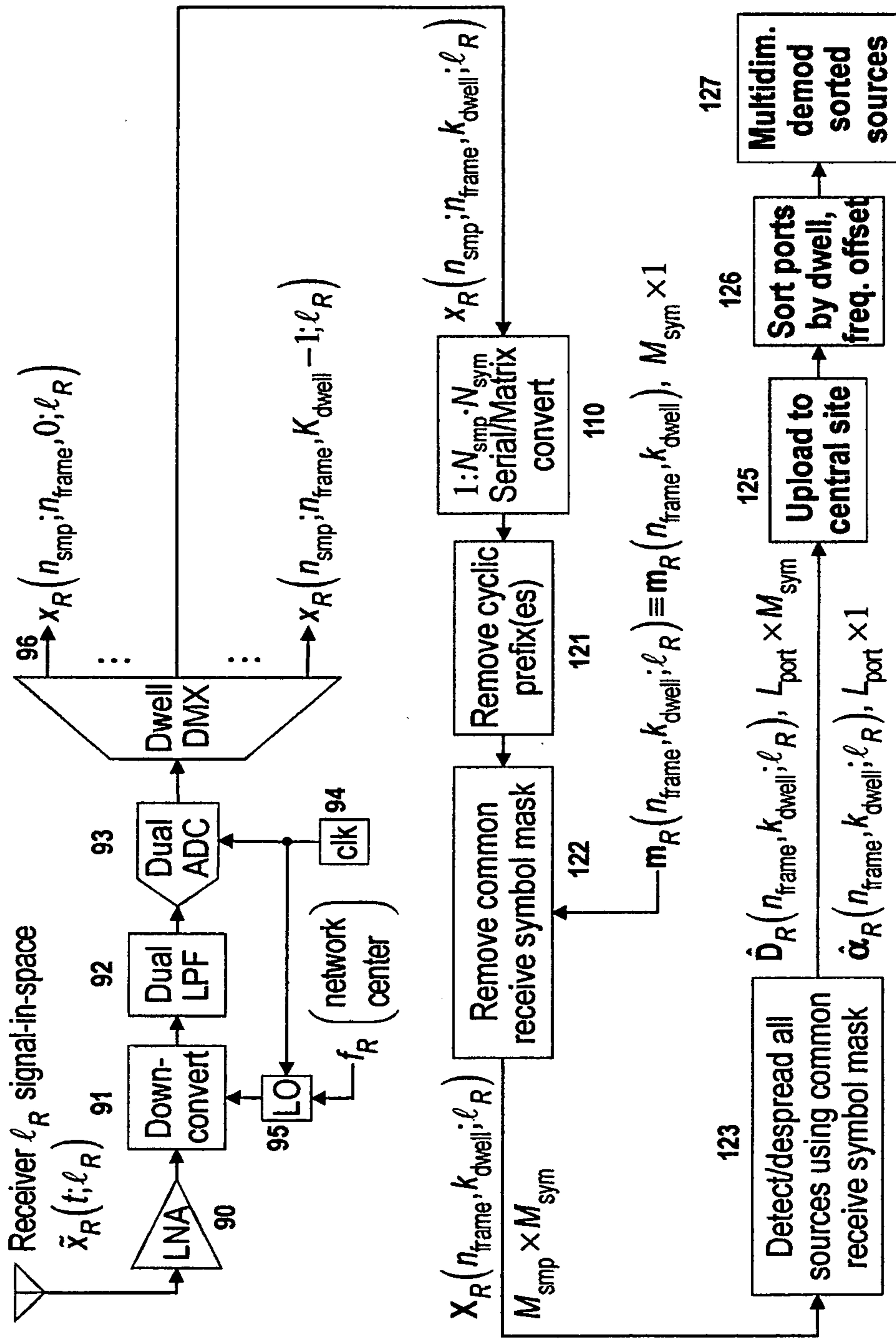

Figure 25

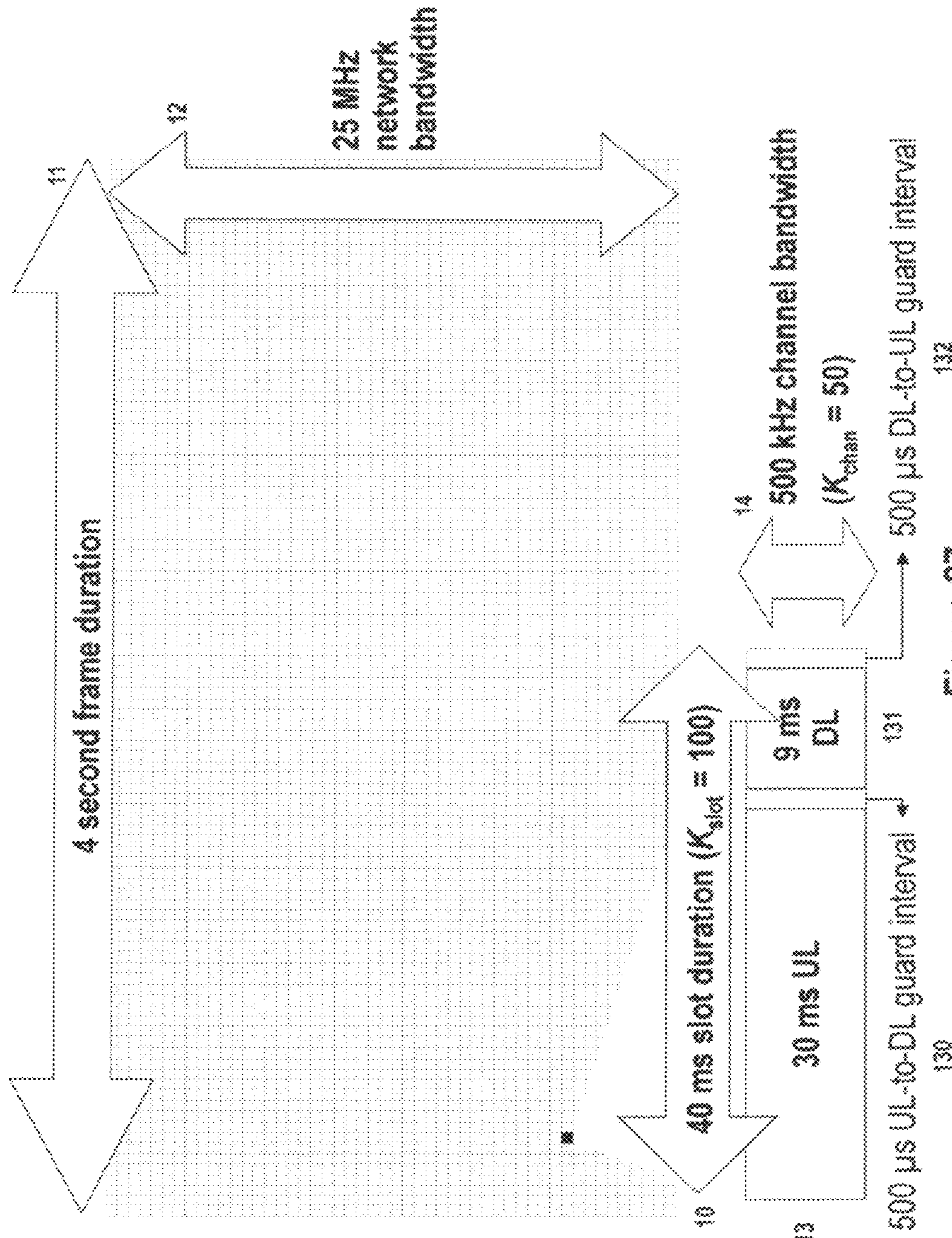

Figure 27

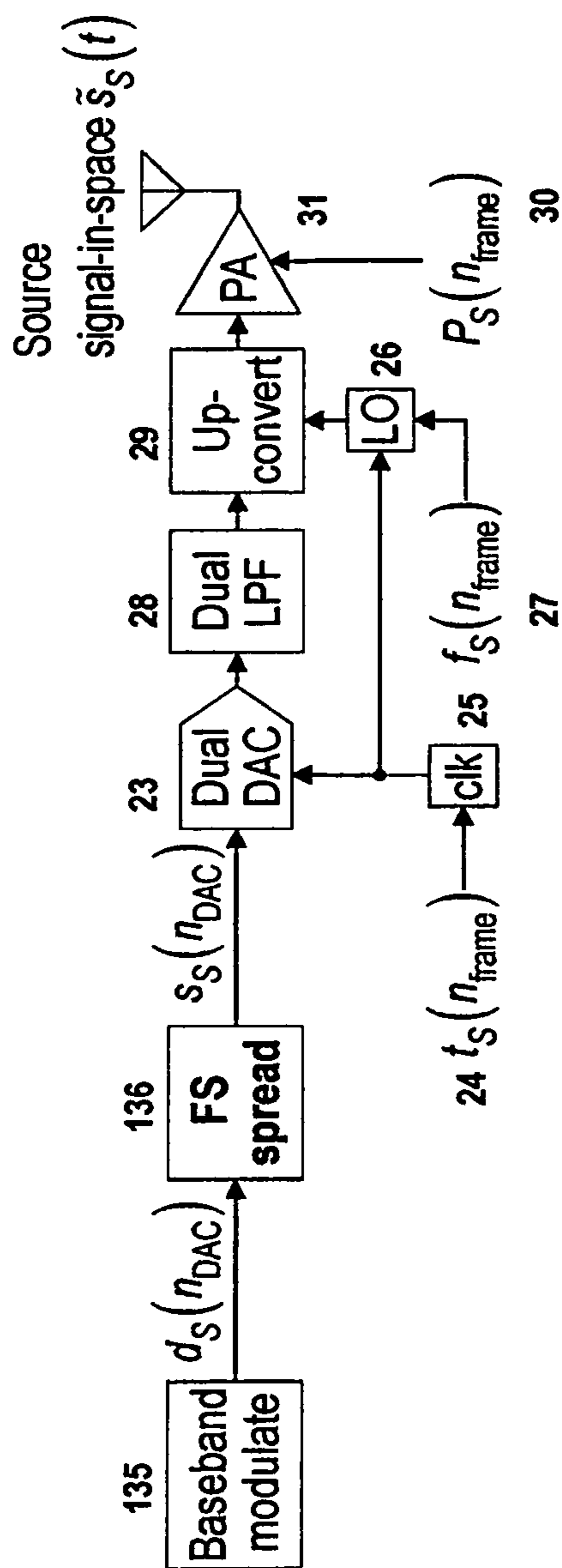

Figure 28

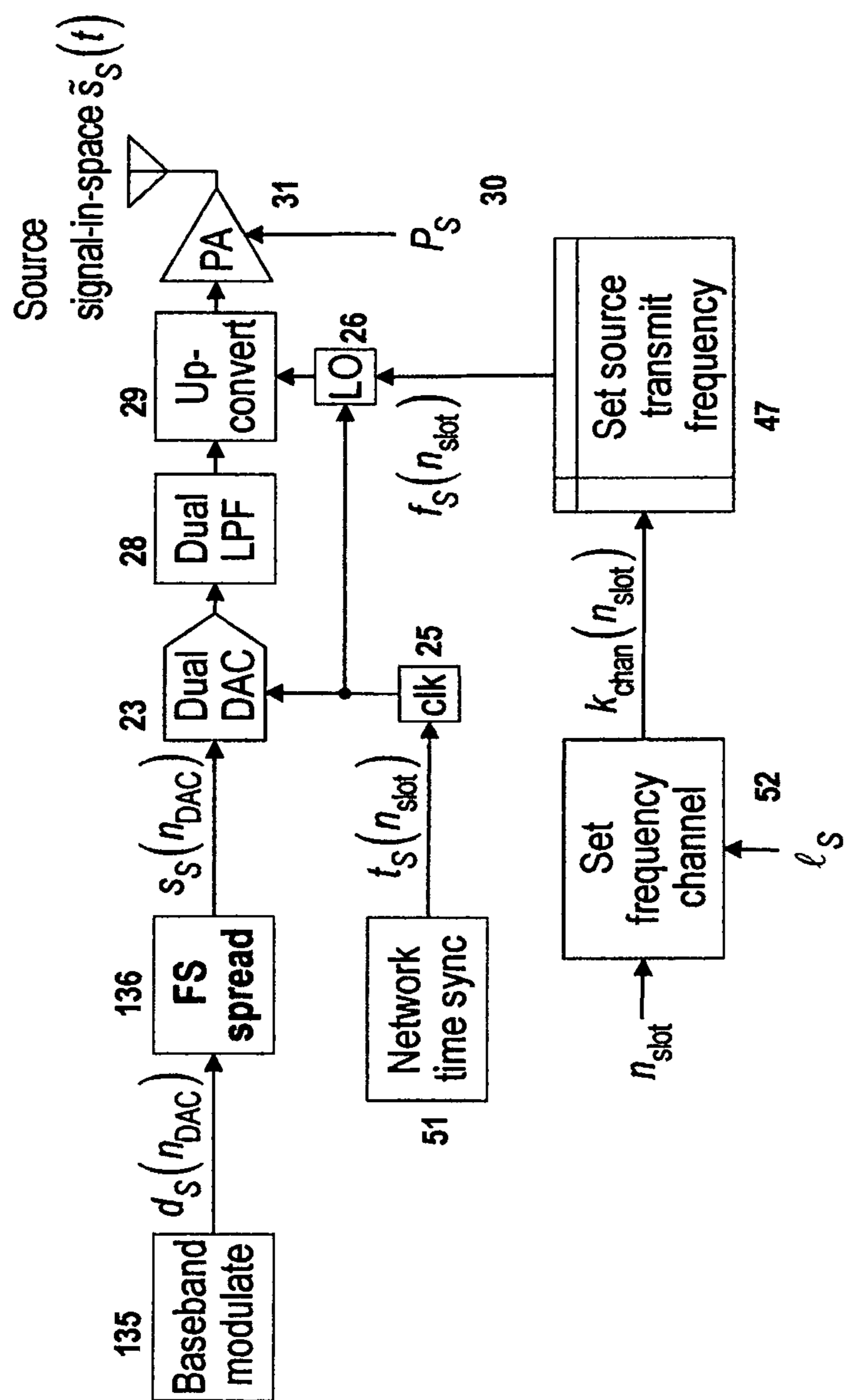

Figure 29

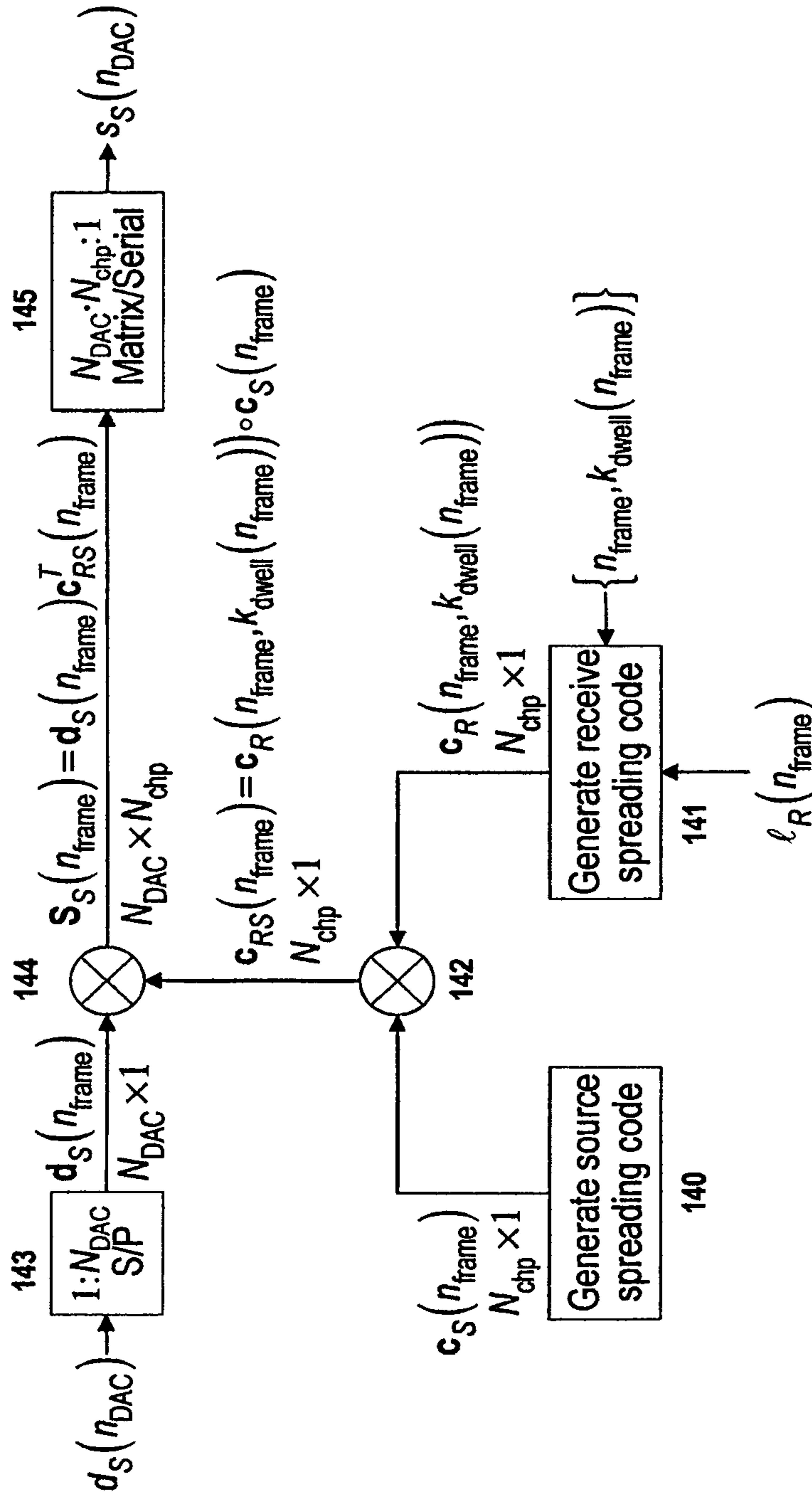

Figure 30

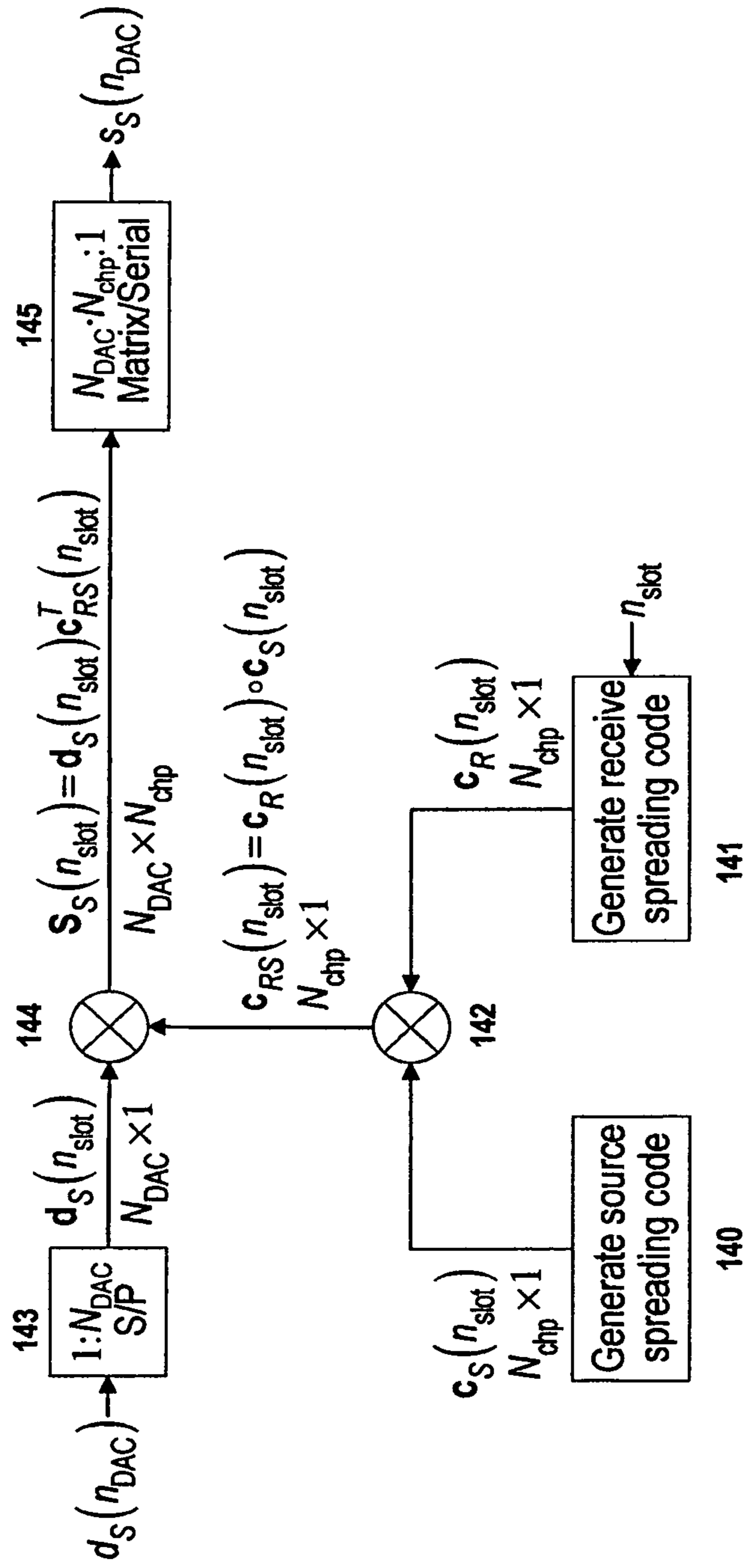

Figure 31

Physically Secure Digital Signal Processing For Wireless M2M Networks; S/N 13/999,040; Inventor: Agee, B. G.; Corrected

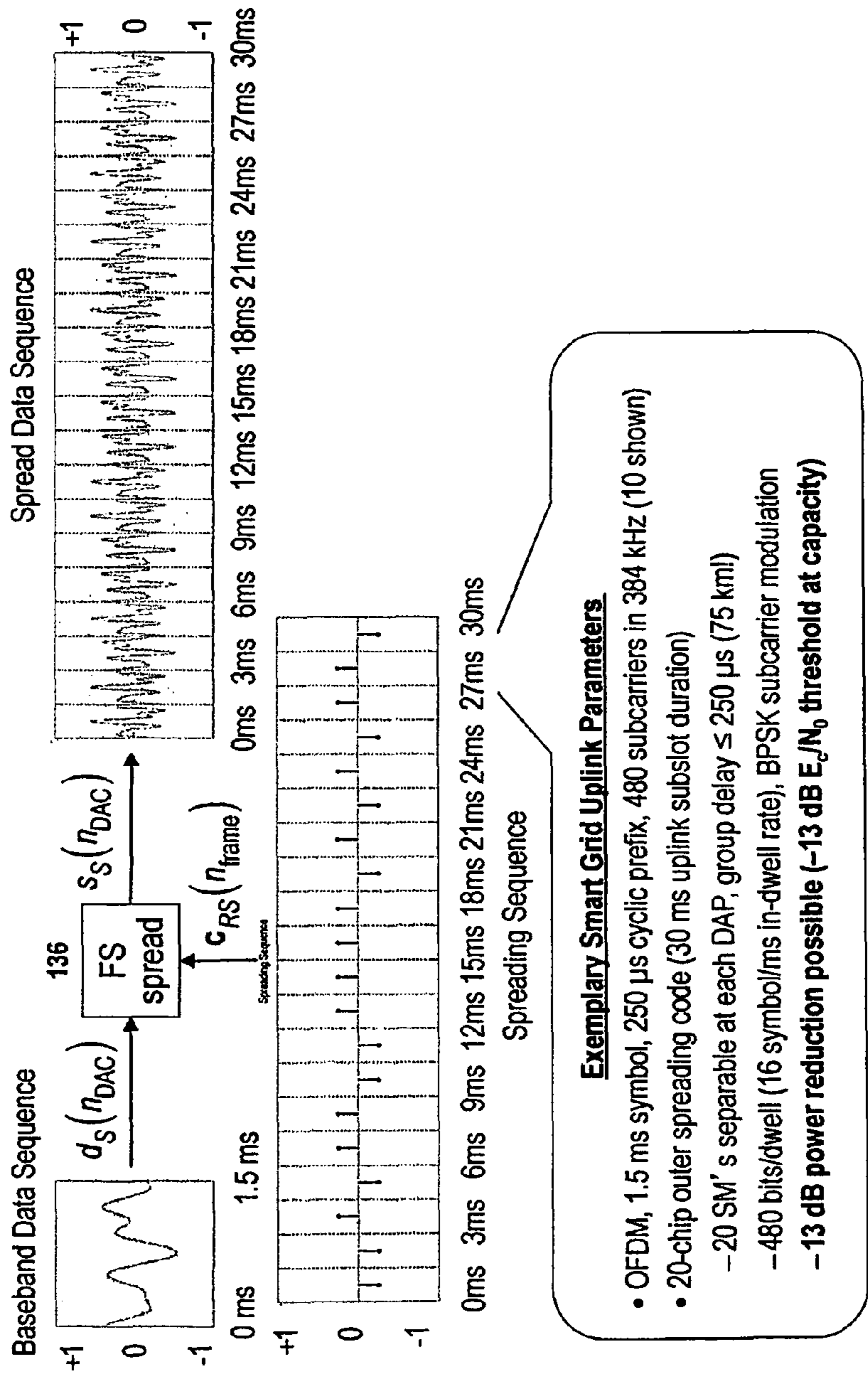

Figure 32

Physically Secure Digital Signal Processing For Wireless M2M Networks; SIN 13/999,040; Inventor: Agee, B. G.; Corrected

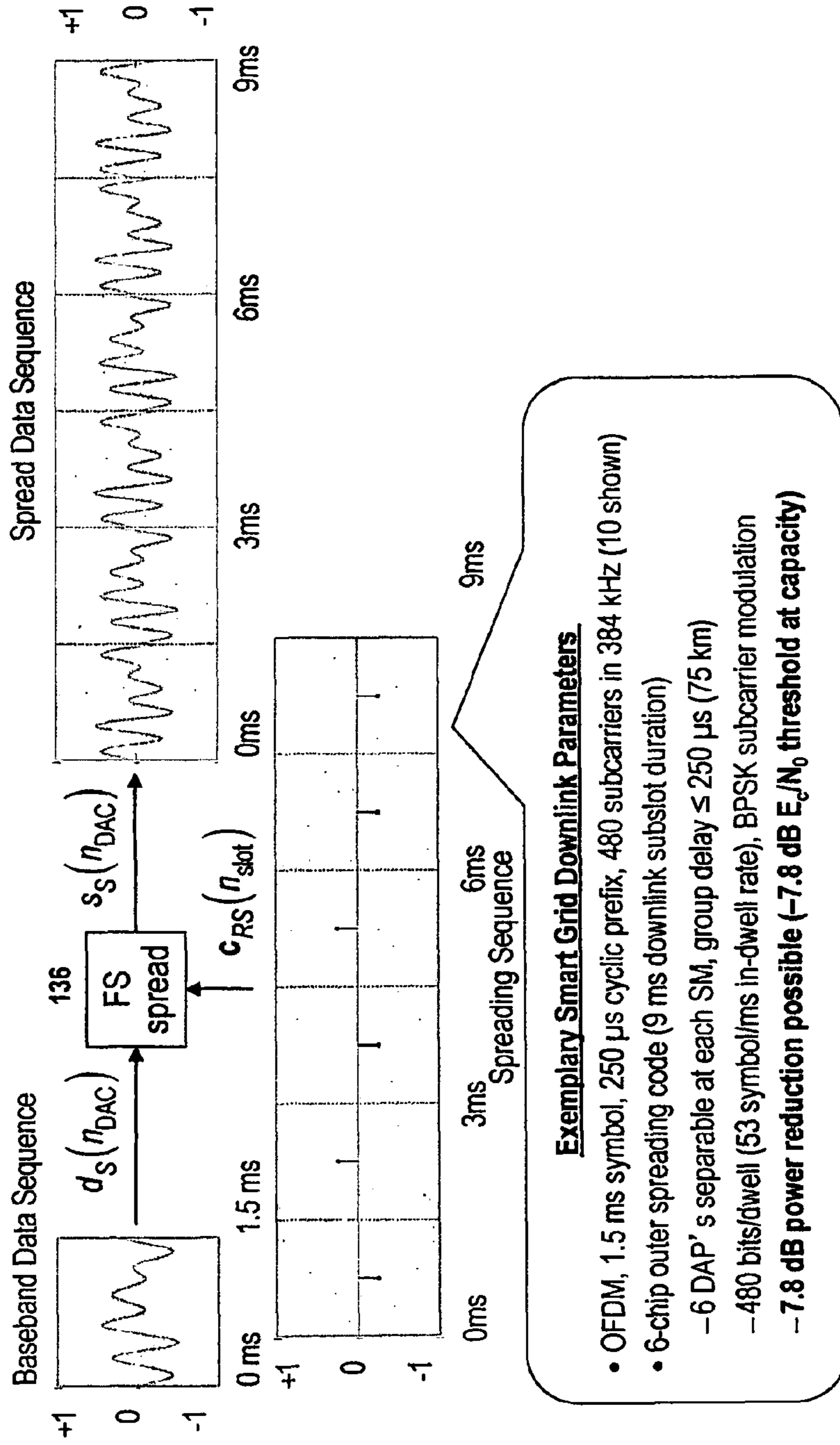

Figure 33

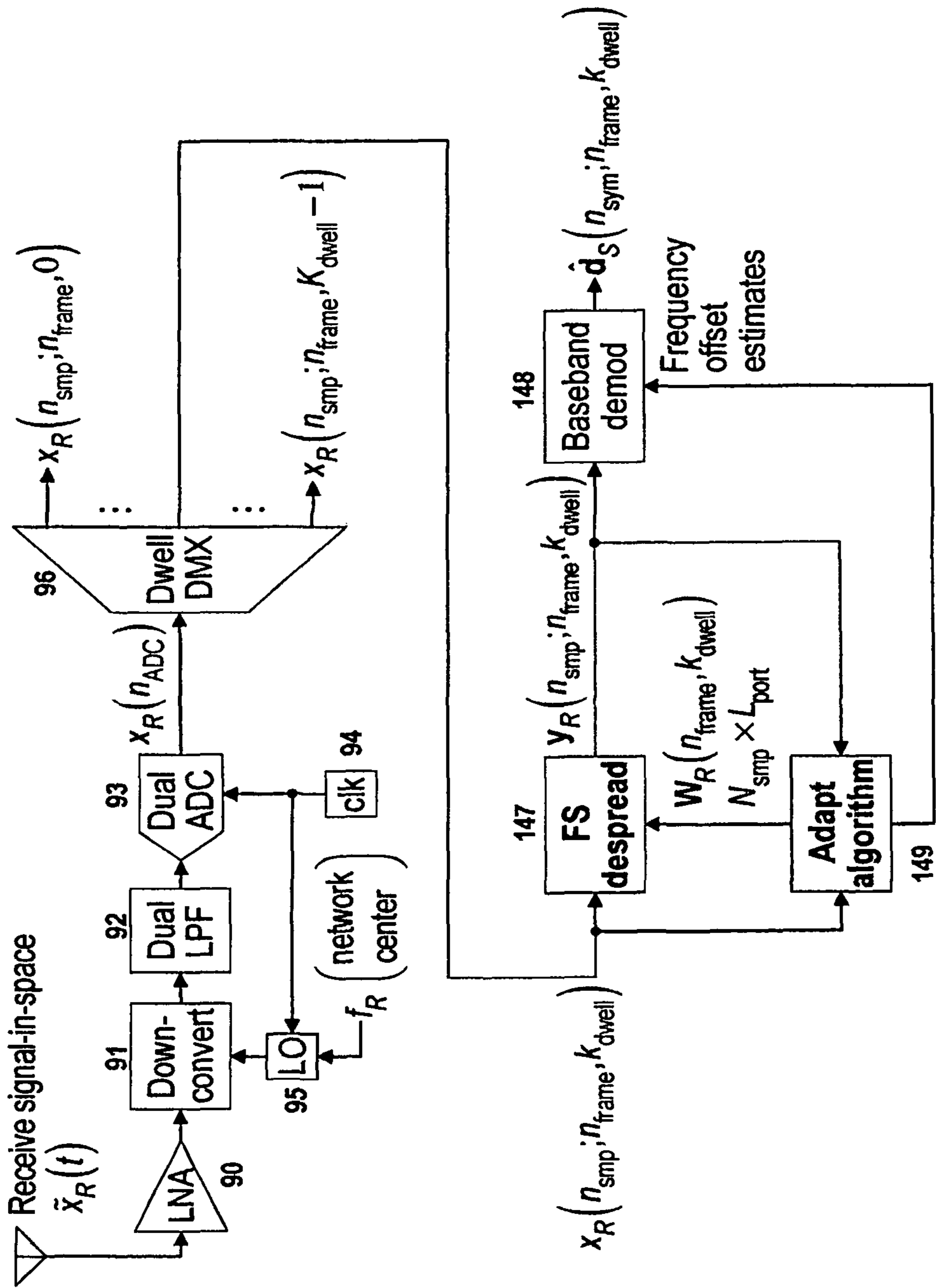

Figure 34

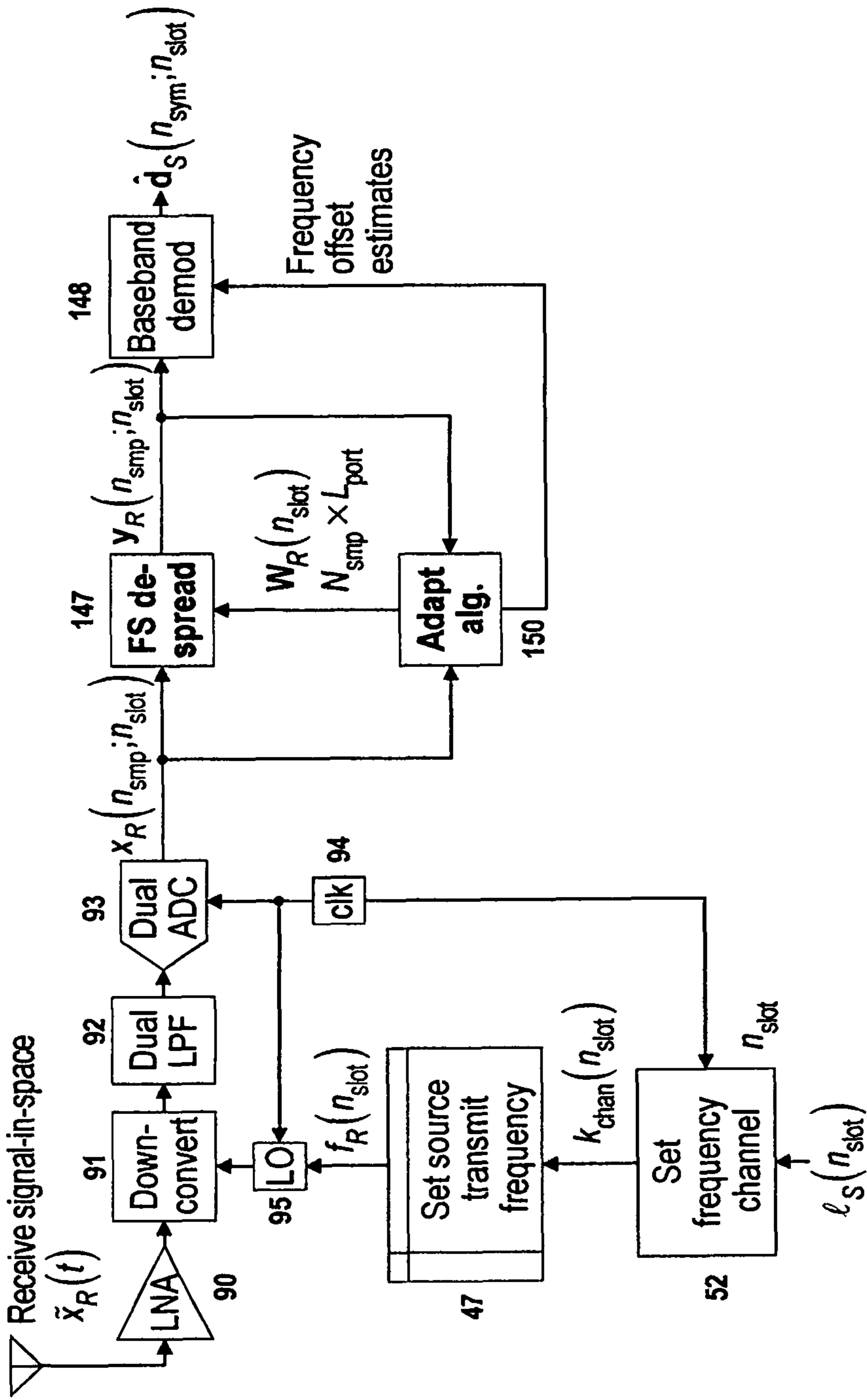

Figure 35

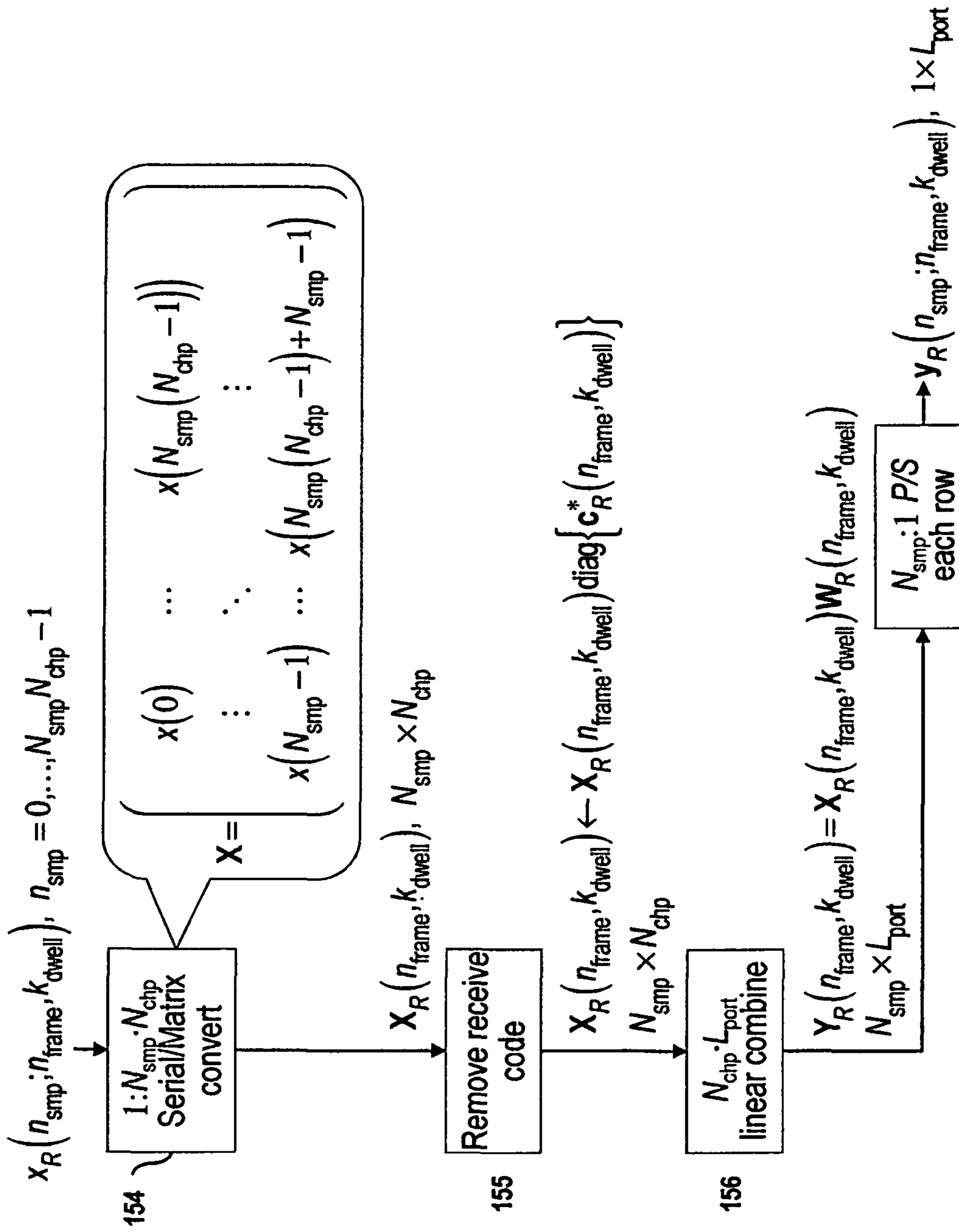

Figure 36 157

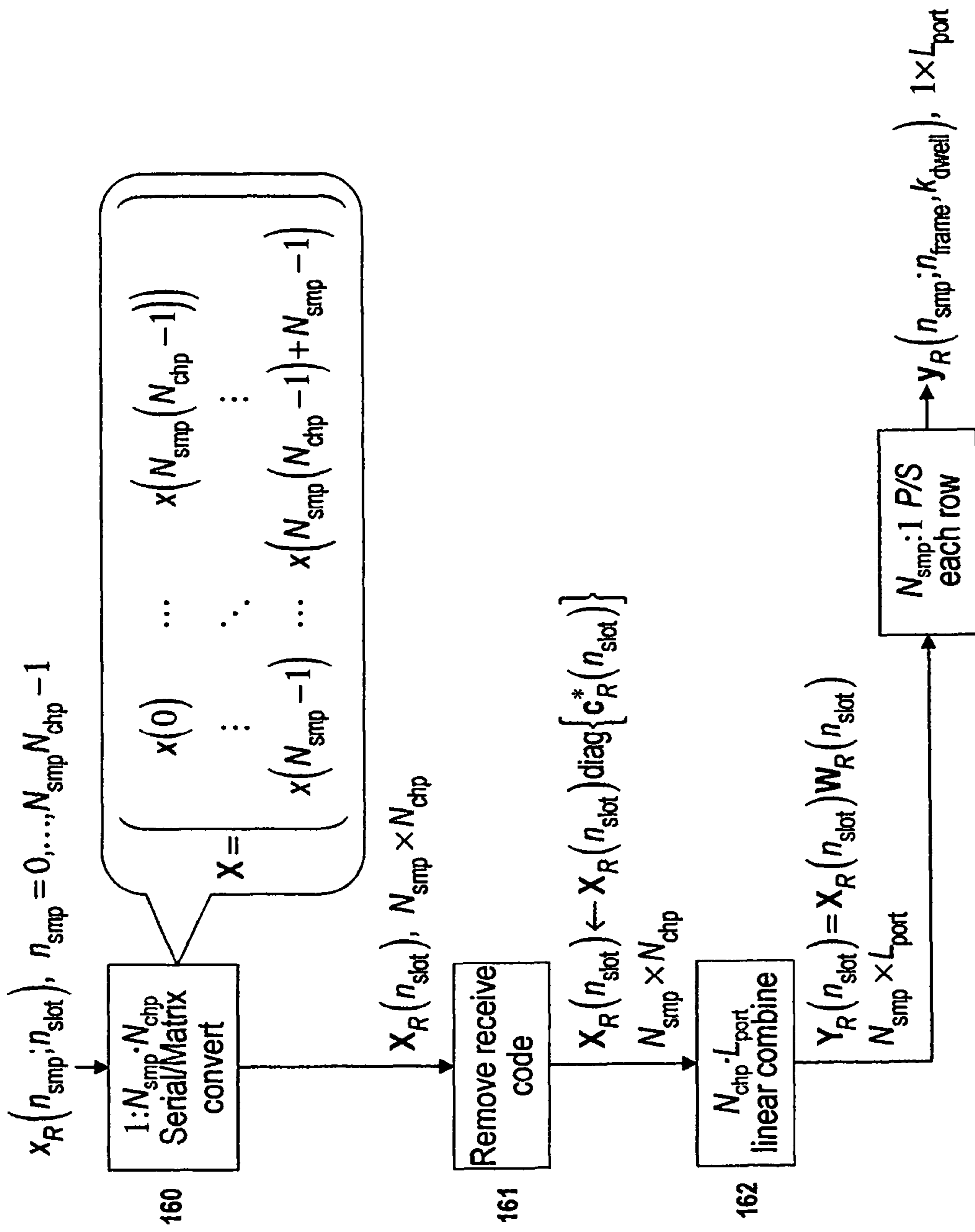

Figure 37 ¹⁶³

**PHYSICALLY SECURE DIGITAL SIGNAL
PROCESSING FOR WIRELESS M2M
NETWORKS**

CROSS REFERENCE TO RELATED
APPLICATIONS

This application for patent claims priority under 35 U.S.C. 119(e), particularly §119(e)(3), from U.S. provisional application filed for the invention described therein by the same inventor which was filed on Jan. 5, 2013 by Express Mail Certificate, Post Office to U.S. Patent and Trademark Office, EM Certificate # EI 449614053 US, and this application and Specification expressly references that original provisional application and incorporates all of that original provisional application's specification and drawings.

STATEMENT REGARDING FEDERALLY
SPONSORED RESEARCH OR DEVELOPMENT

Not Applicable

FIELD OF THE INVENTION

The present invention relates generally to digital signal processing, with particular emphasis on machines wirelessly communicating with each other ("machine to machine" or "M2M" intercommunication) in noisy, crowded, multiple-use and multiple-overlap environments. A majority of this wireless intercommunication may occur with indirect, remote, or otherwise removed human oversight focusing on the network and specific communications rather than implementing and effecting each, or even the majority, of such, as part of a broader intercommunication background of multiple networks of machines comprising what has been called "the internet of things" or IoT. The environment for such wireless intercommunication may be 'noisy' as there may be multiple, chaotic networks operating with different standards and disparate organization, often transmitting highly bursty, asymmetric traffic from many different sources. Blind linear signal separating secure digital processing methods can be used to provide physically secure wireless M2M intercommunications in such environments, without direct human management, and in a manner that is robust, efficient, and interference-resistant.

Signal generation for message and addressing content (respectively, the 'data' containing the information to be communicated and 'metadata' describing the sourcing, routing, and receiver for the message being communicated) is no more to be confused with the specific signals forming the message itself, than the process of combining letters and words of a language into a message and delivering it to a recipient, are with formation and delivery of meaning that that message conveys.

BACKGROUND OF THE INVENTION

Machine-to-machine (M2M) networks comprise a thick mesh of tiered hardware forming the skeleton and body of a communications network, incorporating as desired sensor-and-reporting elements, which effectively comprise a 'nervous system'. Avoiding the time, expense, and effort of physically installing, maintaining, and most particularly adapting wired intercommunication linkages requires that the elements use wireless signals in any, or any set, of electromagnetic spectrum bands.

For any wireless network, providing feedback for regular, directed, and emergency reporting processes all are useful to its continuous operation (particularly when under stress or upon experiencing a failure, whether point, localized, or central, with recovery desired both 'as soon, and as safe, as possible' or 'AS, AAS, AP').

At the 'edges' of the wireless network, every nodal point (home, building, or mobile station) may be a Signaling Machine (SM). Any finite number of Signaling Machines can be aggregated to a lesser order set of Data Aggregation Points (DAP's) each of which serving as an intermediate network distribution point to provide a set of delivery paths with their own capacity or divisibility indices; and these DAP's must also be monitored to avoid unthinking overloads or under-utilizations. DAP's may then transfer the signaling to a wired 'trunk' or background line; but the communication between DAP and SM's may assuredly be in a 'noisy' environment, for at least two readily foreseeable causes.

First, the physical environment of the SM's and DAP's may vary from sub-cell (one DAP, many SM's) to the next, and even within the same sub-cell as vehicles move about, doors open and close, and other physical events occur. So there may be also issues of interference for the network—both within one sub-cell (between SM's and their assigned DAP), and between sub-cells (from adjacent, i.e. geographically, immediately adjacent or overlapping) that are neighbors within the overall network.

Second, the communication between DAP and SM's, in one embodiment operates in the ISM band—which is a shared media. Other devices (e.g. smartphones, wireless printers, and computers) whose penetration and number are rapidly growing, and thus their message traffic, use the ISM band for their own purposes and with their own protocols, timing, and placements that may be ever-changing and unpredictable.

To effect wireless communication under such conditions reliably and efficiently needs digital signal processing which can handle complex, noisy, 'dirty' and above all—uncontrolled and unpredictably varying—communication conditions. This is the background in which the present description takes form.

The principle areas in which M2M communications may take place include (but are not limited to: utility networks (electricity, water, natural gas); industrial operations (as an obvious extension from the former, refineries; but also including manufacturing, distribution/logistical processing, warehousing, and transshipment operations—particularly those switching between modes of transport, e.g. rail-and-truck or truck-and-ship); agricultural and pastoral production (large-scale planting, care, harvesting of grain, truck, or tree crops; or open- or closed-range herds); transportation networks (riverine, including barge/lock/bridge interactions; seabome in channels, harbors, straits, or other 'narrows'; airborne (around or between terminals); and road (including 'convoy' or 'aggregate' vehicle groupings or clusters); healthcare (intra- and inter-provider operations, remote servicing and communications); education (also intra- and inter-provider operations, remote servicing, Massively On-Line Open Courses, reverse-pyramid tutorial schemes, 'educational portal' services); all aspects of value exchange and financial transactions (credit, debit, swap; goods, services, or financial and other 'intangibles'); and social media (ad-hoc peer narrow-, group-, peer-, or open-ended 'casting'; messaging; social calendaring & coordination of 'agents'). The similarity amongst these areas include the following key aspects:

- (a) Potentially high asymmetry between numbers of SM's at the lowest tier or "edge" of the network, and DAP's at higher tiers in the network.
- (b) Potentially high asymmetry in uplink and downlink transmission requirements between network tiers. In the most extreme case (and, in one embodiment, an advantageous case for this invention), SM's at the network edge may preferentially communicate data units to DAP's without any need to requirement for feedback from those DAP's, except for transport of infrequent physical-layer (PHY) messages to set or reset security protocols between the SM's and DAP's. Example services that meet this criterion include User Data Protocol (UDP) and Trivial File Transfer Protocol (TFTP) services.
- (c) Potentially high asymmetry in cost, complexity, size-weight-and-power (SWaP), and energy usage requirements between (typically "dumb") SM's at the network edge and DAP's at higher tiers in the network.
- (b) Transmission of small data bursts, rather than extensive data-heavy, continuing linkages, with low average rate relative to human-centric operational 'norm' at the respective time.
- (d) Rapidly varying and highly dynamic variation in interference observed by SM's and DAP's, comprising both interference generated by the M2M network, and interference generated from emitters operating 'outside' the M2M network.

An individual human may have multiple 'terminals' in such an M2M network everything from physiological sensors in his clothing and accessories, to multiple communications and information-processing devices. An individual 'origination point' may be a single person, a single machine, a single household, or a single building—with greater or lesser 'interior' differentiation and demands.

Power efficiency may be an important criterion for at least some members of the network, as wireless operations may require self-sufficiency for extended periods at non-predictable intervals; without fixed wires, power is more likely to be provisioned by batteries with weight and capacity limitations and thus be more expensive.

Additional important criteria for M2M networks and elements include: mobility, ubiquity, and minimization of maintenance costs (of servicing, of replacement elements, and of 'opportunity of use', i.e. downtime), especially at the network edge; and avoidance of network-centric SM authentication, association, and provisioning requirements that can unduly load the network downlink and create critical points of failure in the network. In particular, the ability to operate with limited or "local" provisioning of security keys can greatly improve robustness and scalability of the network, and (if successfully implemented) eliminate critical points of attack by adversaries seeking to corrupt or penetrate the M2M network.

All of the above criteria (and others known to the field but not specifically described here) generally militate towards a least-cost economic pressure; the networks that are pragmatically operable may be those that can most readily adapt to such. Unlike critical-path, 'must succeed' operations, M2M communications may have to accommodate localized failures, environmentally-caused intermittency, and be able to fail and then recover. The elements and networks can tolerate lower data transmission rates, transmission delays, and flawed communication handovers—using the principle benefit of machines, persistence and exact repetition—to overcome transient faults. They need not be as perfect as possible (in comparison to, say, a human-implanted medical

support device), as durable as manufacturable (in comparison to, say, a multi-decade geosynchronous-orbit communications satellite), or even as secure against failure as imaginable (in comparison, say, to a nuclear reactors in-pile operational machinery). Yet M2M networks and thus the individual elements therein must still be resistant ('hardened') against both inadvertent and intentional 'spoofing' effects (whether these arise from unintentional or intentional mistakes, environmentally-sourced distortions, and sabotage). Continued public acceptance of this approach to M2M networks and their intercommunications requires sustainably high confidence in the validity, verity, and non-distortability of such network's operations, for all SM's and DAP's, all of the time. The security of the network must be trusted even when real-world dangers, be those mistakes or temporary failures, or intentional efforts to misguide, intercept, spoof, or substitute network signals, are present. This security must be secured in and by the real world, rather than exist solely in some perfect model or algorithmic abstraction.

At the present time there are no fixed standards for M2M wireless communications networks that are universal, global, or national. There are cellular, Wi-Fi, and other 'bands' in the electromagnetic spectrum which might be used (and multiple combinations therein might be, also); and the distance ranges for such can shift from short, to close, to mid, to long range crossing the boundaries of skin, clothing, walls, and geography respectively.

Furthermore, because this is an evolving domain, changes can be anticipated to stay both rapid and continuing. Thus an open-ended, rather than closed, proprietary, solution may have the greatest utility. Changes may come to and from each and all of the use of the network, its provisioning and servicing capital (hardware and institutions), its spectra of transmission and reception ('transception'); and its mode of interstitial operation (amplitude, frequency, temporal, spatial, and other diversities of transmission and reception). Chief concerns may include avoiding interference, using low-output power (if only to avoid deafening itself with 'white noise' from such), and intelligent application, sensitive to both the environmental conditions and human-imposed restrictions and requirements (whether regulatory, operational, or standards-compliant).

SUMMARY OF THE INVENTION

The present invention is a method for wireless intercommunication between a set of Signaling Machines (SM's) and a set of Data Aggregation Points (DAP's), comprising within a selected frequency range (in one embodiment, the 902-928 MHz ISM band) a frequency-hop direct-sequence (FHDS) spread-spectrum modulation format, which provides cyclic chip-level and symbol-level cyclic prefixes to control channel multipath and interference loading, and which preferentially employs transmission information that is randomly determined at every node in the network, and neither known to the receivers in the network nor provisioned by the network. On the uplink, this randomly determined transmission information includes:

- the physical dwell (time slot and frequency channel) used by each uplink transmit node in the network, which physical dwell is randomly varied over every time frame;
- the spreading code used by each uplink transmit node in the network, which spreading code is also randomly varied over every time frame; and

elements of a source symbol mask applied to the data bursts prior to spreading, which source symbol mask is also randomly varied over every time frame.

Additionally, if multiple uplink receivers are in the field-of-view (FoV) of the uplink transmitter and have pathloss communication with those receivers, the uplink receiver selected by the uplink transmit node can also be randomly varied over each time frame. On the downlink, this randomly determined transmission information includes:

the spreading code used by each downlink transmit node in the network, which spreading code is randomly varied in every time slot of each time frame; and elements of a source symbol mask applied to the data bursts prior to spreading, which source spreading mask is also randomly varied over every time frame.

Additionally, each downlink transmit node in the network transmits over a downlink frequency channel that is preferentially pseudorandomly varied over each time slot of each frame, using an algorithm that is provided to, known to, or learnable by each downlink receiver(s) allowed to communicate with that downlink transmit node, and which algorithm is locally and independently set at each downlink transmitter.

This randomly-determined transmission information can be provisioned at and by each transmitter, with each intended receiver being blind (no pre-set agreement or provisioning between transmitter and receiver) to the choice of that transmission information, and using only rudimentary provisioning from any specific transmitter in the network to only its set of intended receivers in the network of a commonly-known and shared receive symbol mask for all signals intended for a given receiver(s) so as to differentiate them from transmissions by that specific transmitter intended for other nodes in the network, as well as transmissions from other transmitters in the network intended for that particular receiver(s). The random spreading codes are further exploited at each receiver to differentiate between subsets of nodes transmitting to the same or different receivers in the network, preferentially using linear digital signal processing methods that can separate signals with widely varying receive power, and experiencing arbitrary channel multipath with group delay less than or equal to the cyclic prefix imposed during the spreading operation. This further permits the use of multiple time and frequency coincident transmissions and also avoids provisioning overhead (which reduces data transmission rates) required by using matched-filter despreading.

All of these enable higher security, by greatly complicating the task for any observer to determine actual in-use transmissions from noise; by eliminating the ability for an observer to predict the randomly determined transmission information used at the nodes in the network; and by using linear digital signal processing methods to excise intruders from legitimate network transmissions. For example, even if an intruder has learned the uplink receive symbol mask, so that the intruder can pose as a legitimate uplink transmission, the intruder may not be able to predict the randomly determined uplink transmission information used by any uplink transmitter in the network; will not be able to consistently jam any uplink transmitter in the network; may be instantly identified as a duplicated authorized node, or an unauthorized node, by the uplink receiver, allowing the uplink receive symbol mask to be reset by the system; and may in any event be excised by the linear digital signal processing methods employed by the uplink receiver.

One embodiment has the network exploit these arbitrary spreading codes, enabling this method to be used in any

ad-hoc (not previously designated) set of SM's and DAP's, requiring only the preliminary commonalization (i.e. provisioning, of the symbol mask to the set of SM's and DAP's forming the ad-hoc network); and this method can be employed in any FDMA, TDMA, FHMA or OFDMA (Frequency Diverse Multiple Access; Time Diverse Multiple Access, Frequency Hop Multiple Access, Orthogonal Frequency Diverse Multiple Access) network without scheduling of intercommunications, thereby reducing the feedback response overhead cost. Because the despreading algorithms are not required to be pre-arranged, hard-coded, or otherwise communicated throughout the network, but can be least-common-knowledge shared, fully-blind in nature, they present the lowest overhead for any such approach, do not require carrier synchronization, and enable the SM's and DAP's (the network) to operate without either knowledge of a carrier offset or 'handshake' overhead signaling.

BRIEF DESCRIPTION OF THE DRAWINGS

The present invention is illustrated in the attached presentation explaining some aspects of the present invention, which include Signaling Machine networks (SM's and DAP's) working under various 'loads' of interfering, same-band signals from non-network sources as well as potentially-interfering within-network signals from the sets of SM's and DAP's.

FIG. 1 is a drawing of overlapping and non-cooperating machine-to-machine (M2M) transceivers operating in an exemplary medium-range network, with each sub-network, or cell, containing multiple SM's connecting with a single DAP.

FIG. 2 is a drawing of overlapping and non-cooperating medium-range M2M networks, each with multiple SM's connecting to a single DAP, showing the interference between multiple networks.

FIG. 3 is a drawing of overlapping and non-cooperating medium-range M2M networks, each with multiple SM's connecting to a single DAP, showing the interference from out-of-network devices.

FIG. 4 is a drawing of overlapping and non-cooperating medium-range M2M networks, each with multiple SM's connecting to a single DAP, with an additional intrusive element shown respectively attempting to eavesdrop on, intercept, or interfere with, a network.

FIG. 5 is a drawing of overlapping and non-cooperating machine-to-machine (M2M) transceivers operating in the long-range M2M network, in which a large number of low-complexity M2M transceivers are communicating with a small number of higher-complexity M2M transceivers.

FIG. 6 is a drawing of the time-frequency structure and parameters of each 'frame' used in the Cyclic-Prefix Direct-Sequence (CPDS) system embodiment for the long-range M2M network shown in FIG. 5.

FIG. 7 is a drawing of the hardware implementation at each cyclic-prefix direct-sequence (CPDS) uplink transmitter used in the long-range M2M network embodiment.

FIG. 8 is a drawing of the logical and computational processes performed in each time frame to self-provision network resources used by the CPDS uplink transmitter shown in FIG. 7.

FIG. 9 is a drawing of the hardware implementation at each cyclic-prefix direct-sequence (CPDS) downlink transmitter used in the long-range M2M network embodiment. This Figure includes the logical and computational processes performed in each time slot to self-provision network resources used by the CPDS downlink transmitter.

FIG. 10 is a drawing of the logical and computational processes that implement the Cyclic-Prefix Direct-Sequence (CPDS) Spreader (in one embodiment, comprising digital signal processing hardware) for each uplink transmitter used in the long-range M2M network embodiment shown in FIG. 5, and for time-frequency framing structure shown in FIG. 6.

FIG. 11 is a drawing of the logical and computational processes that implement the CPDS Spreader (again, in one embodiment, comprising digital signal processing hardware) for each downlink transmitter used in the long-range M2M network embodiment shown in FIG. 5, and for the time-frequency framing structure shown in FIG. 6.

FIG. 12 is a drawing of the logical and computation processes that insert a symbol mask onto the baseband data stream input to the CPDS despreaders. This Figure furthermore shows the criteria for adding that symbol mask directly to the baseband data in the 'time domain', or to the data in the 'frequency domain' via incorporation of discrete Fourier transform ('DFT') and inverse DFT ('IDFT') operations.

FIG. 13 shows finer detail of the spreading of the signal within the structure on the exemplary CPDS uplink.

FIG. 14 shows the finer detail of the spreading of the signal within the structure during a downlink.

FIG. 15 shows a CPDS-enabled network element with a real-world, random-number, sourcing-sensor element for modifying the coding.

FIG. 16 shows a CPDS-enabled network element with a real-world, random-number, sourcing-sensor element for setting the dwell index.

FIG. 17 shows a CPDS-enabled network element with a real-world, random-number, sourcing-sensor element by which elements of the source symbol mask, e.g., a cyclic frequency offset, are generated randomly.

FIG. 18 shows a CPDS-enabled network element with a real-world, random-number, sourcing-sensor element by which the intended uplink receiver is selected randomly from a set of candidate uplink receivers over every time frame in a randomizer element and then provided to the CPDS uplink spreader.

FIG. 19 is a drawing of the hardware implementation at each cyclic-prefix direct-sequence (CPDS) uplink receiver used in the long-range M2M network embodiment.

FIG. 20 is a drawing of the hardware implementation at each CPDS downlink receiver used in the long-range M2M network embodiment.

FIG. 21 is a drawing of the CPDS despreading procedure implemented (in any combination of hardware and software elements) on each time-frequency channel accessed by an uplink receiving device in the network.

FIG. 22 is a drawing of the CPDS despreading procedure implemented (in any combination of hardware and software elements) on each time-slot accessed by a downlink receiving device in the network.

FIG. 23 describes the procedure used to adapt the CPDS despreaders in one embodiment.

FIG. 24 is a drawing of the computational and logical processes used to perform CPDS despreading if a cyclic symbol prefix is added to the CPDS transmit signal and the observed path delay at the CPDS receiver is greater than the duration of the cyclic chip prefix.

FIG. 25 is a drawing of the hardware and processing steps used in one embodiment to perform weakly-macrodiverse CPDS despreading.

FIG. 26 is a drawing of the hardware and processing steps used in one embodiment to perform strongly-macrodiverse CPDS despreading.

FIG. 27 is a drawing of the time-frequency structure and parameters of each 'frame' used in the alternate Frame Synchronous (FS) system embodiment for the long-range M2M cell shown in FIG. 5.

FIG. 28 is a drawing of the hardware implementation of the uplink transmitter employed in an alternate embodiment whereby an uplink signal stream is sent through a Frame-Synchronous (FS) Spreader.

FIG. 29 is a drawing of the hardware implementation of the downlink transmitter employed in an alternate embodiment whereby a downlink signal stream is sent through a Frame-Synchronous (FS) Spreader.

FIG. 30 is a drawing of the logical and computational processes that implement the alternate Frame Synchronous (FS) Transmitter Structure (in an alternate instantiation of the alternate embodiment, comprising digital signal processing hardware) for each uplink transmitter used in the long-range M2M network embodiment shown in FIG. 5, and for the time-frequency framing structure shown in FIG. 27.

FIG. 31 is a drawing of the logical and computational processes that implement the alternate Frame Synchronous (FS) Spreading Structure (in an alternate instantiation of the alternate embodiment, comprising digital signal processing hardware) for each downlink transmitter used in the long-range M2M network embodiment shown in FIG. 5, and for the 902-928 MHz time-frequency framing structure shown in FIG. 27.

FIG. 32 shows finer detail of the spreading of the signal within the structure on an exemplary alternate FS uplink.

FIG. 33 shows finer detail of the spreading of the signal within the structure on an exemplary alternate FS downlink.

FIG. 34 is a drawing of a possible hardware implementation at each frame synchronous (FS) uplink receiver used in the alternate long-range M2M network embodiment.

FIG. 35 is a drawing of a possible hardware implementation at each frame synchronous (FS) downlink receiver used in the alternate long-range M2M network embodiment.

FIG. 36 is a drawing of the FS despreading procedure implemented (in any combination of hardware and software elements) on each time-frequency channel accessed by an uplink receiving machine in the network in an alternative embodiment.

FIG. 37 is a drawing of the FS despreading procedure implemented (in any combination of hardware and software elements) on each time-slot accessed by a downlink receiving machine in the network in an alternative embodiment.

DETAILED DESCRIPTION OF THE DRAWINGS

FIG. 1, in one embodiment, is the drawing of overlapping and non-cooperating machine-to-machine (M2M) transceivers operating in an exemplary medium-range network, with each sub-network, or cell, containing multiple SM's (1) connecting with a single DAP (2). Connections between the DAP's (2) or with any other part of a network, are not shown but are not excluded.

FIG. 2, in one embodiment, is the drawing of overlapping and non-cooperating medium-range M2M networks, each with multiple SM's (1) connecting to a single DAP (2), showing the interference (the dotted lines) between multiple networks (specifically, adjacent-cell interference).

FIG. 3, in one embodiment, is the drawing of overlapping and non-cooperating medium-range M2M networks, each with multiple SM's (1) connecting to a single DAP (2), showing the interference from or with out-of-network devices (emitters (3) or receivers (4), respectively).

FIG. 4, in one embodiment, is the drawing of overlapping and non-cooperating medium-range M2M networks, each with multiple SM's (1) connecting to a single DAP (2), with at least one additional intrusive element attempting to intercept (and potentially spoof in a 'man-in-the-middle' attack) (4), eavesdrop on or monitor (5), or interfere with (6), a network.

FIG. 5, in one embodiment, is the drawing of overlapping and non-cooperating machine-to-machine (M2M) transceivers ('nodes') operating in the long-range M2M network, in which a large number of low-complexity M2M transceivers are communicating with a small number of higher-complexity M2M transceivers; with this drawing showing an exemplary application for this network: a wireless, Smart Grid, edge network, in which the low-complexity M2M nodes are Smart Meters (SM's) (8) and the higher-complexity M2M transceivers ('Nodes') are Data Aggregation Points (DAP's) (9). It is assumed that the low-complexity M2M nodes (8) are at a lower elevation restricting their view to a small number of higher-complexity Nodes (9), similar to user equipment 368 ('UE's) in a cellular telephony network, and that the low-complexity M2M nodes (8) have identified a primary or "nearest neighbor" higher-complexity M2M Node (9) in the network. However, it is not assumed that the low-complexity M2M nodes (8) are restricted to, or even preferentially transmit to that primary higher-complexity Node (9).

FIG. 6, in one embodiment, is the drawing of the time-frequency structure and parameters of each 'frame' used in the preferred Cyclic-Prefix Direct-Sequence (CPDS) system embodiment for the long-range M2M cell shown in FIG. 5, shows how on the uplink, each Smart Machine (SM) intending to transmit data to a Data Aggregation Point (DAP) in a 4 second frame first randomly selects one of 5,000 physical time-frequency dwells, comprising 100 contiguous 40 ms physical time slots (10) covering the 4 second frame (11), and frequency-channelized into 50 contiguous kHz physical frequency channels (12) covering 25 MHz of the 902-928 MHz ISM band. The SM then transmits its intended information over a 30 ms uplink (UL) subslot (13) of that time-frequency dwell using a signal employing a cyclic-prefix direct-sequence modulation format. On the downlink, over each 30 ms time slot, each DAP selects one (14) of the 50 physical frequency channels (12) using a pseudorandom selection algorithm known to its intended SM's. The DAP then broadcasts its intended information over a 9.675 ms downlink (DL) subslot (15) of that frequency channel. Each time slot has an additional 75 μ s UL-to-DL guard interval (16) to allow timing advancement of the SM UL transmissions to its primary (but not necessarily preferential) DAP, and a 250 μ s DL-to-UL guard interval (17) to prevent DAP-to-DAP interference from the DAP DL transmissions. Each frequency channel has an additional set-aside of ± 50 kHz guard band to account for carrier local oscillator ('LO') uncertainty and power amplifier ('PA') intermodulation distortion ('IMD') in the transmitted SM and DAP signals. This framing structure allows the SM's and DAP's to be fully compliant with FCC §15.247 regulation for frequency-hop spread spectrum intentional radiators in the 902-928 MHz band. However, the framing structure shown in FIG. 6 can be used with any long-range M2M network in which a large number of low-complexity M2M transceivers are communicating with a small number of higher-complexity M2M transceivers in a manner that is compliant with 902-928 MHz ISM band emission restrictions.

FIG. 7, in one embodiment, is the drawing of the hardware implementation at each cyclic-prefix direct-sequence

(CPDS) uplink transmitter used in the long-range M2M network embodiment. The information to be sent in the intended transmission passes from a baseband encoder (20) successively to the CPDS spreader (21), the raised-root cosine ('RRC') interpolation pulse and pulse-amplitude modulator (PAM') (22), and into at least one digital-to-analog converter ('DAC') (in one embodiment, dual converters) (23). A source transmit start time (' t_S ') for each time frame (' n_{frame} ') (24) is sent to the clock (25) which is both connected to the DAC (23) and the LO (26), which also receives a selected source transmit center frequency (' f_S ') for each time frame n_{frame} (27). From the DAC the now-digital signal is sent through the at least one LPF (28) (in one embodiment, dual LPF's are used) and then to the upconverter (29), which also takes the frequency-specific input from the LO (26). The upconverter then sends the converted digital signal to the PA (31), which also receives a power setting (' P_S ') for each time frame n_{frame} , from where the transmission becomes a wireless signal.

FIG. 8, in one embodiment, is the drawing of the logical and computational processes performed in each time frame to self-provision network resources used by the CPDS uplink transmitter shown in FIG. 7, showing that information is taken from a database of geolocations for both source and candidate uplink receivers (40) and then used to compute the best timing advance to the 'nearest' (which may measure not just geographic separation, but Quality of Signal, least-interference, least-problematic multipath, or other alternate values) uplink receiver (42); that the selection of the dwell index (43) of $k_{dwell}(n_{frame})$ inputs into the calculation of a mapping (44) of $k_{dwell}(n_{frame})$ to the correct time slot index $k_{slot}(n_{frame})$ and frequency channel index $k_{chan}(n_{frame})$, with the correct slot being combined with the frame index n_{frame} to generate the transmit start time (45) which then is used with the best timing advance to calculate (46) the slot start time for each frame index n_{frame} , $t_S(n_{frame})$ (which in FIG. 7 is shown sent to the clock). The frequency channel index $k_{chan}(n_{frame})$ is used to compute (47) both the source transmit center frequency for each n_{frame} , $f_S(n_{frame})$ (which in FIG. 7 is shown sent to the LO), and also along with information taken from a database of candidate uplink receivers (48) from which the intended uplink receiver(s) for each frame index n_{frame} , $I_R(n_{frame})$ is(are) selected (49), combined to set the source transmit power setting for each n_{frame} , $P_S(n_{frame})$ (which in FIG. 7 is shown sent to the PA).

In one embodiment, FIG. 9, the drawing of the hardware implementation at each cyclic-prefix direct-sequence (CPDS) downlink transmitter used in the preferred long-range M2M network embodiment, includes the logical and computational processes performed in each time slot to self-provision network resources used by the CPDS downlink transmitter. In this downlink transmitter, differentiating it from the uplink transmitter described and shown in FIG. 7, instead of a timing signal for each frame, a network time synchronization (51) for the slot start time at each slot index n_{slot} , $t_S(n_{slot})$, is given to the clock (25), and for each slot index n_{slot} and uplink transmitter source index I_S the frequency channel index $k_{chan}(n_{slot})$ is first determined (52) and then used to select the source transmit center frequency (47) which is fed to the LO (26).

In one embodiment, FIG. 10, the drawing of the logical and computational processes that implement the Cyclic-Prefix Direct-sequence (CPDS) Spreader (in one embodiment, comprising digital signal processing hardware) for each uplink transmitter used in the long-range M2M network embodiment shown in FIG. 5, and for the 902-928 MHz time-frequency framing structure shown in FIG. 6,

shows that the CPDS spreader uses a modulation-on-symbol spreading format, in which a spreading code is repeated over each baseband symbol transmitted over a slot. In addition, the spreading structure includes incorporation of cyclic prefixes in both the spreading code and the baseband symbol stream to mitigate multipath and delay uncertainty between the transmitter and receiver in the network; and multiplication of the baseband symbols by a symbol mask that provides PHY security to the signal.

For each frame, from both the intended receiver index $l_R(n_{frame})$ and physical dwell index $k_{dwell}(n_{frame})$ are used to generate its receive symbol mask (60) which in one embodiment takes the form of $M_{sym} \times 1$ vector $m_R(n_{frame}, k_{dwell}(n_{frame}))$ to which a generated source symbol mask (61) of the form of $M_{sym} \times 1$ vector $m_S(n_{frame})$ is combined (62), producing the symbol mask of the form of $M_{sym} \times 1$ $m_{RS}(n_{frame})$ formed by the element-wise (Schur) product

$$m_{RS}(n_{frame}) = m_R(n_{frame}, k_{dwell}(n_{frame})) \circ m_S(n_{frame});$$

to which the converted baseband source symbol stream $b_S(n_{sym})$, after serial-to-parallel (S/P) conversion (63) to $M_{sym} \times 1$ source baseband vector $b_S(n_{frame}) =$

$$b_S(n_{frame}) = [b_S(n_{frame} M_{sym} + n_{sym})]_{n_{sym}=0}^{M_{sym}-1}$$

for frame n_{frame} , has applied on a framewise basis for each n_{frame} (64), producing $M_{sym} \times 1$ source data vector $d_S(n_{frame})$, to which the cyclic symbol prefix is added (65) thus producing $N_{sym} \times 1$ extended source data vector $d_S(n_{frame})$; and a code is generated for each n_{frame} (66), to which the cyclic chip prefix is applied (67), producing $N_{chp} \times 1$ spreading code vector $c_S(n_{frame})$ for each n_{frame} ; after which the twin streams with applied cyclic prefixes are combined (68) producing the $N_{chp} \times N_{sym}$ source signal matrix $S_S(n_{frame})$ of the form

$$S_S(n_{frame}) = c_S(n_{frame}) d_S^T(n_{frame});$$

which is then fed to $N_{chp} \times N_{sym} : 1$ Matrix/Serial converter (69) to produce the source signal stream $s_S(n_{chp})$ (70).

FIG. 11, in one embodiment, is the drawing of the logical and computational processes that implement the CPDS Spreader (again, in one preferred embodiment, comprising digital signal processing hardware) for each downlink transmitter used in the preferred long-range M2M network embodiment shown in FIG. 5, and for the time-frequency framing structure shown in FIG. 6 (which in one embodiment is 902-928 MHz), differs chiefly from FIG. 10 in that the transformations are for each time slot n_{slot} rather than each time frame n_{frame} .

FIG. 12, in one embodiment, is the drawing of the logical and computation processes that insert the symbol mask onto the baseband data stream input to the CPDS despreader, and furthermore shows the criteria for adding that symbol mask directly to the baseband data in the 'time domain', or to the data in the 'frequency domain' via incorporation of discrete Fourier transform ('DFT') and inverse DFT ('IDFT') operations. In this Figure, the frame and dwell indices shown in FIG. 10 for the uplink spreader parameters are not shown, but are understood to be present; and the slot index shown in FIG. 11 for the downlink spreader parameters are not shown, but are understood to be present. The $M_{sym} \times 1$ source baseband vector b_S is first passed through a switch (71), which determines the manner in which the symbol mask is to be inserted. On the upper path (connecting the switch (71) to multiplier element (72)), the $M_{sym} \times 1$ symbol mask m_{RS} is

applied directly to $M_{sym} \times 1$ source baseband vector b_S in the 'time domain' using an element-wise multiplication operation (72), resulting in $M_{sym} \times 1$ source data vector d_S given by $d_S = m_{RS} \circ b_S$, where ' \circ ' denotes the element-wise or Schur matrix product operation. On the lower path (connecting the switch (71) to the 'DFT' element (73)), the $M_{sym} \times 1$ symbol mask m_{RS} is applied to the $M_{sym} \times 1$ source baseband vector b_S in the 'frequency domain', by applying an M_{sym} -point discrete Fourier transform (DFT) operation to b_S (73), resulting in $M_{sym} \times 1$ source baseband subcarrier vector B_S ; applying m_{RS} to B_S using an element-wise multiplication operation (74), resulting in $M_{sym} \times 1$ source data subcarrier vector $D_S = m_{RS} \circ B_S$; and applying an M_{sym} -point inverse DFT (IDFT) to D_S (75), resulting in $M_{sym} \times 1$ source data vector d_S .

Preferentially, the symbol mask is applied to the source baseband vector in the 'time domain' if a cyclic symbol prefix is not inserted in to the source data vector (step (65) shown in FIG. 10 or FIG. 11), i.e., if the cyclic symbol prefix duration $K_{sym} = N_{sym} - M_{sym} = 0$, and the symbol mask is applied to the source baseband vector in the 'frequency domain' if the cyclic symbol prefix is inserted in to the source data vector, i.e., if the cyclic prefix duration $K_{sym} > 0$. However, it should be understood that either insertion method, or any other insertion method that allows the symbol mask to be easily removed at the despreader, can be employed in one embodiment by the embodiments in the present description and that the switch (71) can be interpreted as an actual operation that is explicitly instantiated in the transmitter, or as a choice of insertion methods that can be implemented at the transmitter in one instantiation or another. It should also be understood that the DFT operation (73) can also be dispensed with if the source baseband vector b_S is itself defined in the 'frequency domain,' e.g., as the subcarriers of an OFDM or OFDM-like modulation format.

FIG. 13, the drawing of the finer detail of the spreading of the signal within the structure on the exemplary CPDS uplink, shows how in one embodiment as exemplary Uplink Parameters, it uses 480 symbols, has no cyclic prefix, has 16 symbols/ms for a 30 ms UL hop dwell/slot; incorporates a 20-chip inner spreading code (effecting thereby a 320 chips/ms chip-rate) and for that has a 4-chip (12.5 ms) cyclic prefix. This would enable, for the network, some 20 separable SM's for each DAP, with an observed delay less than 12.5 μ s, tolerating a 3.75 km path spread with timing advancement to the nearest DAP of 10 km cells.

In one embodiment, FIG. 14, the drawing of the finer detail of the spreading of the signal within the structure during a downlink, shows how in one embodiment, as exemplary downlink Parameters, it uses 384 symbols, incorporates a 3 symbol (75 μ s) cyclic prefix, 40 symbols/ms for a 9.675 ms DL hop dwell/slot, incorporates an 8-chip inner spreading code (320 chips/ms chip-rate), and for that has no cyclic prefix (loading accepted). This may enable, for the network, between 4-to-8 DAP's separable for each SM using time-channelized despreading with an observed 6 dB power reduction possible (-6 dB E_c/N_0 BPSK threshold at capacity).

In one embodiment, FIG. 15, the drawing showing a CPDS-enabled network element with a real-world, random-number, sourcing-sensor element for modifying the coding, shows how the real-world, random-number, sourcing sensor (72) provides a truly random kernel input using real-world chance events which is used to generate a random seed (73) from which the spreading code is generated randomly over every transmit opportunity (every time frame n_{frame} on the uplink, and every time slot n_{slot} on the downlink (76)); applying this to a code vector (74) and then adding a cyclic

chip prefix (75) then provided to the CPDS spreader, thereby providing physical, or ‘reality-based’ security rather than algorithmic or model-based security.

In one embodiment, FIG. 16, the drawing showing a CPDS-enabled network element with a real-world, random-number, sourcing-sensor element for setting the dwell index, shows how the real-world, random-number, sourcing sensor (72) provides a truly random kernel input using real-world chance events which is used to generate a random seed (73) which is used to set the dwell index 526 (77) for each frame which is then mapped over slot and channel indices (78) which are then provided to the CPDS uplink transmitter, again providing physical, or ‘reality-based’ security rather than algorithmic or model-based security.

In one embodiment, FIG. 17, the drawing showing a CPDS-enabled network element with a real-world, random-number, sourcing-sensor element that provides a truly random kernel input from a sourcing sensor using real-world chance events (72) from which elements of the source symbol mask, e.g., a cyclic frequency offset, are generated randomly, shows how the generated random seed (73) is used to generate the source symbol mask (79), along with the intended uplink receiver index at frame n_{frame} ($l_R(n_{frame})$) and physical time-frequency dwell index at frame n_{frame} ($k_{dwell}(n_{frame})$) which are combined to generate the receive symbol mask (80), and then the two symbol masks (source and receive) are combined (81) with the result then provided to the CPDS uplink spreader, again providing physical, or ‘reality-based’ security rather than algorithmic or model-based security.

In one embodiment, FIG. 18, the drawing showing a CPDS-enabled network element with a real-world, random-number, sourcing-sensor element that provides a truly random kernel input from a sourcing sensor using real-world chance events (76) from which the intended uplink receiver is selected randomly from a set of candidate uplink receivers, shows how the generated random seed (77) is used to select the uplink receiver at frame n_{frame} ($l_R(n_{frame})$) (49), which is used along with the physical time-frequency dwell index at frame n_{frame} ($k_{dwell}(n_{frame})$) to generate the receive symbol mask (85), which is combined (84) with the source symbol mask (83), and which is further used along with the channel frequency index at frame n_{frame} ($k_{chan}(n_{frame})$) to set the source transmit power at frame n_{frame} ($P_S(n_{frame})$) from a database of transmit powers required to close the link to the intended uplink receiver (50), again providing physical, or ‘reality-based’ security rather than algorithmic or model-based security.

In one embodiment, FIG. 19, the drawing of the hardware implementation at each cyclic-prefix direct-sequence (CPDS) uplink receiver used in the preferred long-range M2M network embodiment, shows whereby the incoming received signal-in-space is received by at least one antenna and low-noise amplifier (‘LNA’) (90), down-converted to complex baseband representation (91) ((in-phase and quadrature analog waveforms) using a local oscillator (‘LO’) (95) tuned to a single frequency (preferentially, the center of the network), whereby the in-phase and quadrature analog waveforms are filtered using a dual lowpass filter (‘LPF’) (92), sampled at a rate (driven by clock (94)) preferentially sufficiently high enough digitize the entire network bandwidth without aliasing using a dual analog-to-digital convertor (‘ADC’) (93), and digitally demultiplexed into physical time-frequency dwells (separated into time slots and frequency channels) accessible to the receiver (96); and whereby each physical dwell is passed through an uplink CPDS despreader (97), modified with a feedback

loop through an adaptation algorithm (98), and each resulting symbol stream is fed through to a symbol demodulator (99) that incorporates the frequency offset estimates also provided by the adaptation algorithm for environmental delay/degradation effects actually observed by the receiving machine.

In one embodiment, FIG. 20, the drawing of the hardware implementation at each CPDS downlink receiver used in the long-range M2M network embodiment, shows whereby the incoming received signal-in-space is received by at least one antenna and LNA (90), down-converted to complex baseband representation (91) using an LO (95) tuned on each time slot n_{slot} to the center of the known frequency channel used by the downlink transmitter on that slot, $f_R(n_{slot})$, and digitized using dual LPF (92) and dual ADC (93) operations over that time slot; and whereby that time slot of data is passed through the downlink CPDS despreader (97) (modified with a feedback loop through an adaptation algorithm (98)), and the resulting symbol stream is fed through to a symbol demodulator (99) that incorporates the frequency offset estimates also provided by the adaptation algorithm for environmental delay/degradation effects actually observed by the receiving machine.

FIG. 21, in one embodiment, is the drawing of the CPDS despreading procedure implemented (in any combination of hardware and software elements) on each time-frequency channel accessed by an uplink receiving machine in the network, if the symbol mask is applied to the baseband source data in the time domain as shown in the upper symbol mask insertion path in FIG. 12, preferentially performed if the cyclic symbol prefix is equal to 0 ($K_{sym}=0$). The N_{smp} N_{sym} -sample received signal sequence

$$\{x_R(n_{smp}; n_{frame}, k_{dwell})\}_{n_{smp}=0}^{N_{smp}N_{sym}-1},$$

output from the dwell demultiplexer (shown in FIG. 19, element (96)) over dwell k_{dwell} and time frame n_{frame} (where N_{sym} is the number of source data symbols transmitted in the dwell and N_{smp} is the number of demultiplexer output samples per source data symbol) is despread by the steps of:

Performing a $1:N_{smp} \times N_{sym}$ serial/matrix conversion (110) on the demultiplexer output signal sequence

$$\{x_R(n_{smp}; n_{frame}, k_{dwell})\}_{n_{smp}=0}^{N_{smp}N_{sym}-1},$$

and removing the K_{smp} -sample cyclic chip prefix and (if applied at the transmitter) the K_{sym} -symbol cyclic symbol prefix from the $N_{smp} \times N_{sym}$ matrix resulting from that serial/matrix conversion operation (111), resulting in $M_{smp} \times M_{sym}$ received signal matrix $X_R(n_{frame}, k_{dwell})$, given mathematically by

$$X = \begin{pmatrix} x(N_{smp}K_{sym} + K_{smp}) & \dots & x(N_{smp}(N_{sym} - 1) + K_{smp}) \\ \vdots & \ddots & \vdots \\ x(N_{smp}K_{sym} + N_{smp} - 1) & \dots & x(N_{smp}(N_{sym} - 1) + N_{smp} - 1) \end{pmatrix}$$

for general received data sequence

$$\{x(n_{smp})\}_{n_{smp}=0}^{N_{smp}N_{sym}-1},$$

and where $K_{smp} = N_{smp} - M_{smp}$ is the number of demultiplexer output samples covering the cyclic chip prefix.

15

Removing the $M_{sym} \times 1$ receive symbol mask vector $m_R(n_{frame}, k_{dwell})$ mask vector over dwell k_{dwell} and time frame n_{frame} from the received signal matrix $X_R(n_{frame}, k_{dwell})$ (112), given mathematically by

$$X_R(n_{frame}, k_{dwell}) \leftarrow X_R(n_{frame}, k_{dwell}) \text{diag}\{m_R^*(n_{frame}, k_{dwell})\}$$

where $\text{diag}\{\bullet\}$ is the vector-to-diagonal matrix conversion operation and $(\bullet)^*$ is the complex conjugation operation, resulting in $M_{smp} \times M_{sym}$ demasked signal matrix $X_R(n_{frame}, k_{dwell})$.

Perform a linear combining operation on demasked signal matrix (113), given mathematically by

$$\hat{D}_R(n_{frame}, k_{dwell}) = W_R(n_{frame}, k_{dwell}) X_R(n_{frame}, k_{dwell}),$$

where $W_R(n_{frame}, k_{dwell})$ is an $L_{port} \times M_{smp}$ linear combining matrix, computed as part of the adaptation procedure shown in FIG. 23, that substantively despreads the source symbols transmitted to the receiver over dwell k_{dwell} and time frame n_{frame} , and to which the symbol mask $m_R(n_{frame}, k_{dwell})$ has been inserted, resulting in $L_{port} \times M_{sym}$ despread symbol matrix $\hat{D}_R(n_{frame}, k_{dwell})$.

Apply $M_{sym}:1$ parallel-to-serial (P/S) conversion operation (114) to each column of $\hat{D}_R(n_{frame}, k_{dwell})$, resulting in $1 \times L_{port}$ despread symbol sequence vectors

$$\{\hat{d}_R(n_{sym}; n_{frame}, k_{dwell})\}_{n_{sym}=0}^{M_{sym}-1}$$

FIG. 22, in one embodiment, is the drawing of the CPDS despreading procedure implemented (in any combination of hardware and software elements) on each time-slot accessed by a downlink receiving machine in the network; and differs chiefly from FIG. 21 in that the transformations are for each time slot n_{slot} rather than each time frame n_{frame} .

FIG. 23, in one embodiment, shows the procedure used to adapt the uplink despreader shown in FIG. 21, and at the downlink despreader structure shown in FIG. 22, by:

1st: Detecting all sources intended for the receiver, estimating key parameters of those signals, and developing linear combining weights that can substantively despread the source symbols, said operations comprising:

1.A computing the QR decomposition (QRD) of the $m_{smp} \times M_{sym}$ received signal X_R , resulting after removal of cyclic prefix(es) and the receive symbol mask;

1.B generating an SINR/carrier revealing feature spectrum that can (i) estimate the maximum attainable despread signal-to-interference-and-noise ratio ('maximum despread SINR') of each signal impinging on the receiver that is employing the receive symbol mask ('authorized signals'), given the received spreading code (source spreading code, modulated by the transmission channel) of each signal and interference impinging on the receiver at the dwell and time-frame being monitored by the receiver, (ii) as a function of observed frequency offset of that signal, and (iii) provide statistics that can be used to develop linear combining weights that can substantively achieve that maximum SINR, without knowledge of the received spreading code for any of those signals, and without knowledge of the background noise and interference environment;

1.C detecting L_{port} significant peak(s), in the SINR/carrier revealing feature spectrum, and determining the maximum despread SINR and frequency offset of each peak;

16

1.D refining strengths (estimated maximum despread SINR) and locations (estimated frequency offsets) of each significant peak, e.g., using Newton search methods; and

1.E developing $L_{port} \times M_{sym}$ linear combiner weight matrices W_R that can substantively achieve the maximum despread SINR for each authorized signal, without knowledge of the received spreading code for any of those signals, and without knowledge of the background noise and interference environment.

Then:

2nd: Despreading and demodulating the detected sources, said operations comprising:

2.A Substantively despread the sources detected in Step 1.C, by multiplying the demasked signal matrix provided at the output of (112) in FIG. 21 and FIG. 22 by the substantively despread linearly combining linear combiner weights computed in Step 1.E, said matrix multiplication operation shown in element (113) in FIG. 21 and FIG. 22.

2.B Substantively remove frequency offset from the despread symbols, using the frequency offset estimates computed in Step 1.D.

2.C Estimate and correct phase offsets, and further refine frequency offsets to algorithm ambiguity using known features of the source symbols, e.g., adherence to known symbol constellations, unique words (UW's) and training sequences embedded in the source symbols, known properties of the source symbol mask, etc.;

2.D Remove algorithm ambiguity using additional features of the source symbols, e.g., UW's, forward error correction (FEC), cyclic redundancy check's (CRC's), etc.; and

2.E Decrypt traffic and protected medium access control (MAC) data.

Then:

3rd: Perform ancillary processing as needed/appropriate:

3.A Compute received incident power (RIP) for open-loop power control, using SINR and channel estimates provided by the CPDS despreading algorithm (uplink receiver);

3.B Correlate source internals, externals with trusted information, using dwell, intended receiver and source symbol mask elements provided by the CPDS receiver and despreading algorithm; and

3.C Detect network intrusions revise symbol masks if needed (downlink receiver).

FIG. 24, in one embodiment, is the drawing of the CPDS despreading procedure implemented (in any combination of hardware and software elements) on each time-frequency channel accessed by an uplink receiving machine in the network, if the symbol mask is applied to the baseband source data in the frequency domain as shown in the lower symbol mask insertion path in FIG. 12, preferentially performed if the cyclic symbol prefix is greater than 0 ($K_{sym} > 0$). The $N_{smp} N_{sym}$ -sample received signal sequence

$$\{x_R(n_{smp})\}_{n_{smp}=0}^{N_{smp} N_{sym}-1}$$

input to the despreader is despread by the steps of:

Passing

$$\{x_R(n_{smp})\}_{n_{smp}=0}^{N_{smp} N_{sym}-1}$$

through a $1:N_{smp}N_{sym}$ serial-to-parallel (S/P) converter (115), and removing the first K_{sym} symbols ($N_{smp}K_{sym}$ samples) encompassing the cyclic symbol prefix from the resultant $N_{smp}N_{sym} \times 1$ S/P output vector (116), resulting in $N_{smp}M_{sym} \times 1$ received data vector x_R .

Performing a $N_{smp}M_{sym}$ -point discrete Fourier transform (DFT) operation (117) on x_R (thereby converting it to the 'frequency domain'); reshaping the $N_{smp}M_{sym} \times 1$ DFT output vector into an $N_{smp} \times M_{sym}$ matrix using a $1:M_{sym}$ S/P converter and matrix transpose operation (118), resulting in $N_{smp} \times M_{sym}$ received data matrix X_R . Removing the $M_{sym} \times 1$ receive symbol mask vector m_R mask vector from X_R (112), given mathematically by

$$X_R \leftarrow X_R \text{diag}\{m_R^*\}$$

where $\text{diag}\{\bullet\}$ is the vector-to-diagonal matrix conversion operation and $(\bullet)^*$ is the complex conjugation operation, resulting in $M_{smp} \times M_{sym}$ demasked signal matrix X_R .

Perform a separate linear combining operation to each column of demasked signal matrix X_R (119), given mathematically by

$$\hat{D}_R(:,k_{sym}) = W_R(k_{sym})X_R(:,k_{sym}), k_{sym}=0, \dots, M_{sym}-1,$$

where $W_R(k_{sym})$ is an $L_{port} \times M_{smp}$ linear combining matrix, computed as part of the adaptation procedure shown in FIG. 23, that substantively despreads the DFT bin ('subcarrier') k_{sym} of each of the source symbols detected by the receiver, and to which the symbol mask m_R has been inserted, resulting in $L_{port} \times M_{sym}$ despread symbol subcarrier matrix \hat{D}_R .

Apply $M_{sym} \times 1$ -point inverse DFT (IDFT) to each row of \hat{D}_R (120), and $M_{sym} \times 1$ parallel-to-serial (P/S) conversion operation (114) to each column of the resultant IDFT output matrix, resulting in $L_{port} \times 1$ despread symbol sequence vectors

$$\{\hat{d}_R(n_{sym})\}_{n_{sym}=0}^{M_{sym}-1}.$$

FIG. 25, in one embodiment, is the drawing of the hardware and processing steps used in one embodiment to perform weakly-macrodiverse uplink CPDS despreading. The uplink receiver performs the same uplink reception, dwell demultiplexing, and adaptive despreading operations shown in FIG. 19; the same uplink despreading operations shown in FIG. 21 or FIG. 24 (depending on how the symbol mask is inserted as shown in FIG. 12); and the same despreader adaptation procedure shown in FIG. 23. However, the CPDS network employs a common receive symbol mask (122) at a set of $L_R > 1$ uplink receivers in the network, such that the $M_{sym} \times 1$ receive symbol mask $m_R(n_{frame}, k_{dwell}; l_R)$ used over physical dwell k_{dwell} in time frame n_{frame} at each uplink receiver

$$\{\ell_R\}_{\ell_R=1}^{L_R}$$

in that set is identical, i.e., $m_R(n_{frame}, k_{dwell}; l_R) = m_R(n_{frame}, k_{dwell})$ for every receiver in that set.

At uplink receiver l_R used for weakly-macrodiverse uplink despreading, and if the symbol mask is inserted into the baseband source symbols using the time-domain method shown on the upper path of FIG. 12, each signal sequence

$$\{x_R(n_{smp}; n_{frame}, k_{dwell}; \ell_R)\}_{n_{smp}=0}^{N_{smp}N_{sym}-1}$$

output from the dwell demultiplexer (96) is passed through a serial/matrix converter (110) and a matrix thinning operation to remove the cyclic prefixes from the serial/matrix converted symbol matrix (122), and the common receive symbol mask is removed from the resultant data matrix using the multiplicative operation (112) shown in FIG. 21, resulting in $M_{smp} \times M_{sym}$ demasked data matrix $X_R(n_{frame}, k_{dwell}; l_R)$. The demasked data matrix is then adaptively despread using the linear combining operation shown in FIG. 21 (113), and using the despreader adaptation procedure shown in FIG. 23 (123), which detects L_{port} sources using the common receive mask; computes an $L_{port} \times 1$ frequency offset vector

$$\hat{\alpha}_R(n_{frame}, k_{dwell}; \ell_R) = [\hat{\alpha}_R(n_{frame}, k_{dwell}; \ell_{port}, \ell_R)]_{\ell_{port}=1}^{L_{port}}$$

where $\hat{\alpha}_R(n_{frame}, k_{dwell}; l_{port}; l_R)$ is an estimate of the frequency offset of the signal detected on port l_{port} ; estimates and substantively despreads the signal detected on each output port, resulting in $L_{port} \times M_{sym}$ despread data matrix $\hat{D}_R(n_{frame}, k_{dwell}; l_R)$.

The despread data matrix and frequency offset vector from every uplink receiver engaged in weakly-macrodiverse despreading is then uploaded to a central site (125), where the signal ports from each such receiver are sorted by dwell, frequency offset estimate, and other source observables, e.g., cross-correlation properties and known symbol fields, e.g., Unique Words, to associate signals detected at each port with the same source (126), and each sorted source is demodulated into source symbol estimates using a multidimensional demodulation algorithm (127).

If the symbol mask is inserted in the frequency domain, as shown on the lower path of FIG. 12, then the serial/matrix conversion operation (110) and the cyclic prefix(es) removal operation (121) shown in FIG. 25 are replaced by the serial/parallel conversion (115), cyclic symbol prefix removal (116), DFT (117) and serial-to-parallel conversion, and transposition (117) operations shown in FIG. 24, and the frequency offset estimates and despread data matrix output from the column-by-column linear combining (119) and IDFT (120) operations is uploaded to the central site (125).

FIG. 26, in one embodiment, is the drawing of the hardware and processing steps used in one embodiment to perform strongly-macrodiverse CPDS despreading. The CPDS network employs the same common receive symbol mask for a set of $L_R > 1$ uplink receivers in the network, and performs the same operations shown in FIG. 25 to generate $M_{smp} \times M_{sym}$ demasked data matrix $X_R(n_{frame}, k_{dwell}; l_R)$ after removal of that common receive symbol mask (122). The entire demasked data matrix is then uploaded to a central site (125), where it is stacked with the demasked data matrices uploaded from every other receiver using that common receive symbol mask (128), to form $L_R M_{smp} \times M_{sym}$ network data matrix $X_R(n_{frame}, k_{dwell})$ given by

$$X_R(n_{frame}, k_{dwell}) = \begin{pmatrix} X_R(n_{frame}, k_{dwell}; 1) \\ \vdots \\ X_R(n_{frame}, k_{dwell}; L_R) \end{pmatrix}, \quad (\text{Eq 1})$$

The network data matrix is then passed to a network-level despreader (97), which employs the adaptation procedure (98) shown in FIG. 23 to detect L_{port} sources using the common receive mask; computes an $L_{port} \times 1$ frequency offset vector

$$\hat{\alpha}_R(n_{frame}, k_{dwell}) = [\hat{\alpha}_R(n_{frame}, k_{dwell}, \ell_{port})]_{\ell_{port}=1}^{L_{port}}$$

where $\hat{\alpha}_R(n_{frame}, k_{dwell}, \ell_{port})$ is an estimate of the frequency offset of the signal detected on port ℓ_{port} ; and compute $L_{port} \times M_{smp} \times L_R$ linear combiner weights $W_R(n_{frame}, k_{dwell})$. Those weights are then used to despread the stacked receive data vector (97), resulting in $L_{port} \times M_{sym}$ despread data matrix $\hat{D}_R(n_{frame}, k_{dwell})$. It should be noted that the number of output ports L_{port} achievable at the central site can be much higher than the number of output ports achievable at any single site, due to the higher number of linear combiner ‘degrees of freedom’ $M_{smp} \times L_R$ available in the stacked receive signal matrix.

In one embodiment, FIG. 27, the drawing of the time-frequency structure and parameters of each ‘frame’ used in the alternate Frame Synchronous (FS) system embodiment for the long-range M2M cell shown in FIG. 5, shows the framing structure similar to the CPDS framing structure shown in FIG. 6, except in this embodiment the durations of the DL subslots (131) are 9 ms, and the preceding and following guard intervals (130, 132) are each 500 μ s. This framing structure again allows the SM’s and DAP’s to be fully compliant with FCC §15.247 regulation for frequency-hop spread spectrum intentional radiators in the 902-928 MHz band. However, these much higher guard intervals allows the alternate FS network to be used in applications where the SM’s and/or DAP’s are communicating over much longer ranges or at much higher altitudes, e.g., in airborne or satellite communication networks. In addition, this frame structure provides sufficient guard interval to eliminate the need for SM timing advancement in many applications.

In one embodiment, FIG. 28, the drawing of the hardware implementation of the uplink transmitter employed in an alternate embodiment whereby an uplink signal stream is sent through a Frame-Synchronous (FS) Spreader (136), is structurally the same as the CPDS uplink transmitter shown in FIG. 7, except that the FS embodiment does not integrate the baseband modulation and spreading operations, but instead directly spreads baseband signals using any baseband modulation format (135).

In one embodiment, FIG. 29, the drawing of the hardware implementation of the downlink transmitter employed in an alternate embodiment whereby a downlink signal stream is sent through a Frame-Synchronous (FS) Spreader (136), is structurally the same as the CPDS downlink transmitter shown in FIG. 9, except that the FS embodiment does not integrate the baseband modulation and spreading operations, but instead directly spreads baseband signals using any baseband modulation format (135).

FIG. 30, in one embodiment, is the drawing of the logical and computational processes that implement the alternate Frame Synchronous (FS) Transmitter Structure (in the instantiation of the alternate embodiment, comprising digital signal processing hardware) for each uplink transmitter used in the long-range M2M network embodiment shown in FIG. 5, and for the 902-928 MHz time-frequency framing structure shown in FIG. 27. N_{DAC} -sample baseband source

sequence $d_S(n_{DAC})$ intended for transmission over time-frame n_{frame} is first passed to a $1:N_{DAC}$ serial-to-parallel (S/P) convertor (143) resulting in $N_{DAC} \times 1$ source symbol vector

$$d_S(n_{frame}) = [d_S(n_{frame}N_{DAC} + n_{DAC})]_{n_{DAC}=0}^{N_{DAC}-1}$$

The source symbol vector is then spread over time (144) using an $N_{chp} \times 1$ spreading code vector $c_{RS}(n_{frame})$, mathematically given by

$$S_S(n_{frame}) = d_S(n_{frame})c_{RS}^T(n_{frame}),$$

resulting in $N_{DAC} \times N_{chp}$ data matrix $S_S(n_{frame})$, followed by an $N_{DAC} \times N_{chp} : 1$ matrix-to-serial conversion operation (145) to convert $S_S(n_{frame})$ to a $(N_{DAC}N_{chp})$ -chip scalar data stream $s_S(n_{DAC})$, in which each column of $S_S(n_{frame})$ is serially converted to a scalar data stream, moving from left to right across the matrix.

This Figure also shows $c_{RS}(n_{frame})$ being constructed from the element-wise multiplication (142) of an $N_{chp} \times 1$ source spreading code $c_S(n_{frame})$ (140) that is unique to the uplink transmitter and randomly varied between time frames, and an $N_{chp} \times 1$ receive spreading code $c_R(n_{frame}, k_{dwell}(n_{frame}))$ (141) that is pseudorandomly varied based on the time frame n_{frame} , the physical dwell $k_{dwell}(n_{frame})$ employed by the receiver over time frame n_{frame} , and the intended uplink receiver $l_R(n_{frame})$. However, if the baseband source vector has known or exploitable structure, the entire code vector can be constructed locally using random spreading code.

FIG. 31, in one embodiment, is the drawing of the logical and computational processes that implement the alternate Frame Synchronous (FS) Spreading Structure (in one instantiation of the alternate embodiment, comprising digital signal processing hardware) for each downlink transmitter used in the long-range M2M network embodiment shown in FIG. 5, and for the 902-928 MHz time-frequency framing structure shown in FIG. 27, differs chiefly from FIG. 30 in that the transformations are for each time slot n_{slot} rather than each time frame n_{frame} .

In one embodiment, FIG. 32, the drawing showing finer detail of the spreading of the signal within the structure on an exemplary alternate FS uplink, shows how in this embodiment as exemplary Uplink Parameters, it employs a baseband OFDM signal modulation with a 1.5 ms symbol period including a 250 μ s cyclic prefix (1.25 ms FFT duration, or 0.8 kHz subcarrier separation), allowing transport of 480 subcarriers in 384 MHz of active bandwidth, effecting thereby a 16 symbol/ms in-dwell information symbol rate; and incorporates a 20-chip outer spreading code, enabling each DAP in the network to detect, despread, and separate up to 20 SM emissions intended for that DAP, or to excise as many as 19 SM emissions intended for other DAP’s in the network. In addition, the cyclic prefix employed by the baseband modulation format provides up to 250 μ s of group delay tolerance, equivalent to a 75 km path spread. This path spread is sufficient to eliminate the need for timing advancement of the uplink transmitters in the long-range communication application described in FIG. 5.

In one embodiment, FIG. 33, the drawing showing finer detail of the spreading of the signal within the structure on an exemplary alternate FS downlink, shows how in this embodiment as exemplary Downlink Parameters, it employs the same baseband modulation format as the uplink spreader, allowing transport of 480 subcarriers in 384 MHz of active bandwidth, effecting thereby a 16 symbol/ms

in-dwell information symbol rate; and incorporates a 6-chip outer spreading code, enabling each SM in the network to detect, despread, and separate up to 6 DAP emissions, or to excise as many as 5 DAP emissions intended for other SM's in the network. The cyclic prefix employed by the baseband modulation format again provides up to 250 μ s of group delay tolerance, equivalent to a 75 km path spread.

In one embodiment, FIG. 34, the drawing of a possible hardware implementation at each frame synchronous (FS) uplink receiver used in the alternate long-range M2M network embodiment, shows whereby the incoming received signal-in-space is received at antenna(e), down-converted from the analog incoming waveforms, and demultiplexed into physical dwells (96) accessible to the receiver; and whereby each physical dwell is passed through an uplink FS despreader (147) (modified with a feedback loop through an adaptation algorithm (149) to detect and substantively despread the FS signals received on each dwell), and each resulting substantively despread signal stream is fed through to a baseband demodulator (148), is structurally the same as the CPDS uplink receiver shown in FIG. 19, except that the FS embodiment does not integrate the baseband symbol demodulation operations, but instead despreads baseband signals using any baseband modulation format (147).

In one embodiment, FIG. 35, the drawing of a possible hardware implementation at each frame synchronous (FS) downlink receiver used in the alternate long-range M2M network embodiment, differs chiefly from FIG. 34 in that the transformations are for each time slot n_{slot} rather than each time frame n_{frame} .

In one embodiment FIG. 36, the drawing of the logical and computational processes that implement the alternate Frame Synchronous (FS) Despreader Structure (in one instantiation of the alternate embodiment, comprising digital signal processing hardware) for each uplink transmitter used in the long-range M2M network embodiment shown in FIG. 5, show despreading of the demultiplexed uplink data sequence

$$\{x_R(n_{smp}; n_{frame}, k_{dwell})\}_{n_{smp}=0}^{N_{smp}N_{chp}-1}$$

received in k_{dwell} over time frame n_{frame} by performing the sequential steps of:

Performing a $1:N_{smp} \times N_{chp}$ serial-to-matrix conversion operation (154) on the demultiplexer output signal sequence

$$\{x_R(n_{smp}; n_{frame}, k_{dwell})\}_{n_{smp}=0}^{N_{smp}N_{chp}-1},$$

resulting in $N_{smp} \times N_{chp}$ matrix $X_R(n_{frame}, k_{dwell})$, given mathematically by

$$X = \begin{pmatrix} x(0) & \dots & x(N_{smp}(N_{chp}-1)) \\ \vdots & \ddots & \vdots \\ x(N_{smp}-1) & \dots & x(N_{smp}(N_{chp}-1) + N_{smp}-1) \end{pmatrix}$$

for general received data sequence

$$\{x(n_{smp})\}_{n_{smp}=0}^{N_{smp}N_{chp}-1}.$$

Removing the $N_{chp} \times 1$ receive spreading code $c_R(n_{frame}, k_{dwell})$ from $X_R(n_{frame}, k_{dwell})$ (155), given mathematically by

$$X_R(n_{frame}, k_{dwell}) \leftarrow X_R(n_{frame}, k_{dwell}) \text{diag}\{c_R^*(n_{frame}, k_{dwell})\}$$

where $\text{diag}\{\bullet\}$ is the vector-to-diagonal matrix conversion operation and $(\bullet)^*$ is the complex conjugation operation.

Computing $N_{smp} \times L_{port}$ despread baseband signal matrix $Y_R(n_{frame}, k_{dwell})$ (156), given mathematically by

$$Y_R(n_{frame}, k_{dwell}) = X_R(n_{frame}, k_{dwell}) W_R(n_{frame}, k_{dwell}),$$

where $W_R(n_{frame}, k_{dwell})$ is an $N_{chp} \times L_{port}$ linear combining matrix computed using the procedure shown in FIG. 23.

Converting the despread baseband signal matrix $Y_R(n_{frame}, k_{dwell})$ back to a sequence of $1 \times L_{port}$ despread baseband signal vectors

$$\{\hat{d}_R(n_{sym}; n_{frame}, k_{dwell})\}_{n_{sym}=0}^{M_{sym}-1}$$

by applying an $N_{smp}:1$ parallel-to-series (P/S) conversion operation (157) to each row of $Y_R(n_{frame}, k_{dwell})$.

In one embodiment, FIG. 37, the drawing of the logical and computational processes that implement the alternate Frame Synchronous (FS) Spreading Structure (in one instantiation of the alternate embodiment, comprising digital signal processing hardware) for each downlink transmitter used in the long-range M2M network embodiment shown in FIG. 5, and for the 902-928 MHz time-frequency framing structure shown in FIG. 27, differs chiefly from FIG. 36 in that the transformations are for each time slot n_{slot} rather than each time frame n_{frame} .

DETAILED DESCRIPTION OF EXEMPLARY EMBODIMENTS

While this invention is susceptible of embodiment in many different forms, there is shown in the drawings and will herein be described in detail several specific embodiments with the understanding that these specific embodiments of the present disclosure are to be considered as individual exemplifications of the principles of the invention and not intended to limit the invention to the embodiments illustrated.

The embodiments described herein presume a hardware implementation that uses a single antenna per transceiving element, to which any of a set of spatial excision/separation methods of digital signal processing may be applied, including: Linear demodulators (which provide the benefits, among others, of low complexity, simpler network coordination); blind and/or uncalibrated adaptation algorithms; and Subspace-constrained partial update (SCPU) (in order to minimize adaptation complexity). In a further embodiment, more than one antenna may be used and additional dimensions of diversity (spatial, polarization, or any combinations thereof) thus enabled, applied to the excision/separation/security DSP.

The embodiments further provide physical security as an intended but ancillary benefit to overall network efficiency, as the method enables any or all of the following in individual elements, sub-sets of elements, or the entire set comprising the network, while sending messages: Pseudo-random or truly random spreading to prevent exploitation of

compromised codes; Fast code replacement (“code hopping”) to prevent exploitation of detected codes; and Low-power transmission modes to minimize detect footprint, defeat remote exploitation methods.

There are further network enhancements as an intended ancillary benefit, which include: Coordinated/simultaneous SM uplink transmission, DAP reception; the Elimination/enhancement of slotted ALOHA, TDMA protocols; Reduced interference presented to co-channel users; and Provable improvement using information theoretic arguments. Plus, the overall effect enables the network to function with both Blind/uncalibrated SM downlink reception and, consequently, the elimination/minimization of network coordination (and the required signal overhead to effect the same) at each SM.

In one embodiment, a method is provided for wireless intercommunication between at least one Signaling Machine (‘SM’) and one Data Aggregation Point (‘DAP’) each belonging to a set of like devices (all capable of both transmitting and receiving) and with all said devices belonging to the same network of which each said device is a node. Because this method is extremely flexible and adaptable, as described herein all embodiments disclosed in the present description must be understood to be used by collections of devices where members of a specific collection may be both like (e.g. multiple SM’s in Collection A) and disparate (a single DAP also in Collection A). Intercommunication may be between a first node and a second node, or a single node and multiple nodes, or multiple nodes to single node, or multiple nodes to multiple nodes. So at least one SM and at least one DAP may intercommunicate; likewise, more than one SM with a single DAP, more than one DAP with a single SM, multiples of SM’s with multiples of DAP’s; and SM’s may intercommunicate with other SM’s and DAP’s may intercommunicate with other DAP’s, in any combination. Each SM and DAP may be referred to as a ‘node’, a ‘device’, and (depending on their current activity and role) may be the transmitter, receiver, or transmitter and receiver of a message (or intercommunication, or intended transmission); but calling the device a transmitter (or receiver) for its functional activity at the time, is not usage to be confused with and taken as, requiring or stating that the device as a whole be solely that specific electronic component.

The FHDS spread-spectrum modulation is effected through spreading codes, and its format comprises time slots and frequency channels which combine to form a ‘time frame’; so the time slots and frequency channels are subdivisions of the time frame. Any transmission may comprise at least one time frame (and probably more), an uplink and a downlink, and comprise both at least one data burst (a time period of active transmission) and at least one guard interval (a time period of no transmission) (as seen in FIGS. 6 and 27). Transmission information—which is not the content of the transmission, but its structure, nature, recipient(s), spreading code(s), and other such ‘metadata’—may be not provisioned by the network nor known to the receivers in the network, but locally determined, by any device for its intended sub-set of other devices to which the transmission is to be intercommunicated. This transmission information may be any of provisioned, pseudorandomly selected, and randomly selected, by the transmitting device and varied, likewise.

As one embodiment of the method uses blind fully-despreading algorithms at each receiver, the network can implement arbitrary spreading codes (to distinguish intercommunications between each SM and DAP, or sub-sets or sets thereof); and these arbitrarily spreading codes can be

chosen randomly, pseudorandomly, or locally (that is, without coordination or activation/change effort on the part of the network as a whole, i.e. without centralized network provisioning).

Furthermore, and equally importantly to the continued security, even when, while, or after any attempted infiltration or interception, the selection of arbitrarily spreading codes actually used within the network as a whole can be altered (again randomly, pseudorandomly, and locally) with any timing and by any ad-hoc redivision of the network, thereby preventing any third party from learning, or predicting, and thus gaining access to, the intercommunications between any sub-set of SM’s and their DAP’s. By using the spreading codes to differentiate intended signaling between the SM’s and DAP, this method prevents mutual interference amongst its elements.

To obtain the kernel for implementing a truly randomized spreading code, in at least one further embodiment the network incorporates at least one real-world sensor which takes input from events in the real world as the source for random-number generation (a real-world, random-number, sourcing sensor, or ‘RW-RN-SS’). For example, the network may have an amplitude sensor which picks the most powerful signal within a time frame; or a photovoltaic sensor which detects the intensity of a light shining through a set of heat-variant-density liquid containers (lava lamps’), or a frequency sensor which selects the mean, average, peak or low, or other calculated value, of all frequencies detected within a certain time period. The method can then be using, during said transformations, input from a real-world, random-number, sourcing-sensor element that provides a truly random kernel using real-world chance events for randomly effecting the transmission transformation, including any combination of the following set: by randomly generating the spreading code over every transmit opportunity (every frame on the uplink, and every time slot on the downlink) in a randomizer element and then providing the generated spreading code to the CPDS spreader; by randomly generating the physical dwell index (time slot and frequency channel) over every time frame in a randomizer element and then providing said randomly generated physical dwell index to the CPDS uplink transmitter; by randomly generating elements of the source symbol mask, e.g., a cyclic frequency offset, over every time frame in a randomizer element and then providing said randomly generated physical dwell index; and, by randomly selecting an intended uplink receiver from a set of candidate uplink receivers over every time frame and then providing that selection of uplink receiver to the CPDS uplink spreader.

Thus the environment as a whole—including the ‘noise’ of all other transmissions—can become a self-sourcing aspect of the network’s security, using genuinely random and constantly-changing real-world events instead of a mere ‘pseudorandom noise’ (‘PN’) element.

In another and further embodiment each DAP incorporates in itself a RW-RN-SS to generate for that DAP and its associated SM’s, the truly randomized spreading code(s) used by that subset of the network.

In yet another and further embodiment each SM incorporates in itself a RW-RN-SS to generate for that SM, the truly randomized spreading code(s) used by it.

Furthermore, the successful interception and detection of one spreading code does nothing to ensure further, continued, or future interception of any messages (within the affected sub-set of the network, or any part or whole of the network. As soon as the intercepted spreading code is

changed the new messages may be once again not merely encrypted, but become part of the overall ‘noise’ of the total environment.

As a consequence, the method completely eliminates the ability for an adversary to predict or control when, where in frequency, or even whom an SM may transmit to at any time. In the worst case scenario where the anti-spoofing protocols are compromised, an adversary can at best generate a duplicate node that is easily detected and identified by the network using PHY observables (e.g. carrier offsets, locational angles, intensity variations, timing inconsistencies, multipath imbalances, etc. as known to the state of the art, which in a transmission may be the Physical Layer (‘PHY’) data bits), internals, or other trusted information possessed by the true SM and DAP. Whenever a node is duplicated the original source and intended recipient can, each independently or together, compare any of the PHY observables in the received transmissions and use any discrepancy from previously observed values to identify the adversarial node; and then ignore that now-identified hostile node, alert the other nodes in the network to the presence, and PHY observable characteristics, of that now-identified hostile node, and otherwise respond.

One embodiment enables randomized and/or decentralized time-frequency hopping and code spreading to defeat interception/deception attacks that focus on scheduled transmissions (including, among others, the ‘man-in-the-middle’ interception type of attack). Indeed, one embodiment eliminates the very existence of feedback paths needed to schedule uplink transmissions, thereby negating a critical point of attack for intruders attempting to intercept, jam, spoof, or otherwise disrupt the network, as well as reducing downlink network loading imposed by those paths.

Further still, another embodiment also differs from the prior art in implementing physical security which neither depends on every element having an antennae array, nor which inherently exploits channel differences resulting from differing geographical placement of those arrays, yet which allows both signaling between a SM and a DAP (or a ‘user’ and a ‘base station’) and a pair of SM’s or a pair of DAP’s with the same physical security and processing implementation, and without network-assigned differentiation of processing methods.

One embodiment focuses on Max-SINR rather than matched-filter despreading, uses fully-blind rather than parametric despreading, and employs conventional LMMSE (Linear Minimum Mean-Squared Spreading Error), because this method greatly reduces the overhead to the network (signal-controlling and signal-defining sub-content) of its transmissions, which correspondingly increases the efficiency and capacity of the network. It also enables a back-compatible approach (to existing communication signal, e.g. 802.11 DSSS) whenever and wherever desired, enabling cost-effective implementation as signal/noise densities become problematic, rather than an ‘entirely new generation’ implementation effort where the entire network must be simultaneously upgraded as a prerequisite to the attainable improvement(s).

A further embodiment combines cyclic time prefixes and specific guard intervals that allow operation of any SM’s-DAP network (or sub-portion), in an environment with very coarse time synchronization, without any significant loss of signal density or range of effectiveness.

In one embodiment the method fits each transmission into a series of frames of Upload (‘UL’) and Download (‘DL’) transmissions (FIG. 6). Each frame comprises a frame structure with a 4-second frame period and 25 MHz fre-

quency bandwidth within the 902-928 MHz ISM band, divided into 5,000 physical time-frequency dwells, comprising 100 contiguous 40 ms physical time slots covering the 4 second frame, and frequency-channelized into 50 contiguous 500 kHz physical frequency channels. Each physical time-frequency dwell is further subdivided into a 30 ms UL subslot in which an SM can transmit to a DAP; a 9.675 ms DL subslot in which a DAP can transmit to an SM; a 75 μ s UL-to-DL guard interval between the UL and DL subslots to allow timing advancement of the SM UL transmissions to its primary (but not necessarily preferential) DAP, and a 250 μ s DL-to-UL guard interval between the end of the DL subslot and the next time slot to prevent ‘DAP-to-DAP interference’ caused by DAP DL transmission into the next time slot. Each 500 kHz frequency channel has an additional set-aside of ± 50 kHz guard band to account for carrier LO uncertainty and PA intermodulation distortion (IMD) in the transmitted SM and DAP signals.

This frame structure enables a Point-to-Multipoint (‘P2MP’) transmission that is compliant with ‘intentional radiator’ exceptions under the FCC §15.247 requirements for the 902-928 MHz band. Moreover, the DL is broadcast from the DAP, thereby avoiding the Point-Multi-Point (‘P-MP’) restriction and making it compliant with FCC §15.247 requirements for the 902-928 MHz band.

In one embodiment, the network used a method incorporating into each transmission at each transceiver a Cyclic-Prefix Direct-Sequence (CPDS) modulation-on-symbol spreader and fully-blind despreader within each physical time-frequency channel, thus providing a differentiator for that transmission with time-channelized despreading to further support the robustness and quality of the differentiation of signal from noise within the accepted transmission band. Furthermore, this spreading format incorporates randomization features that also eliminates the need for pre-deployment network planning and enables and allows more robust (mesh, macrodiverse) network topologies, improving and increasing the stability and robustness of the actually deployed network. A reasonable estimate is that this multiplies the potential capacity for the network by a factor of 3, compared to conventional FHDS networks; or allows link connection at 10-20 dB lower power level with the same fidelity. Using a single-carrier prefix also minimizes signal loading due to multipath or in-cell group delay. In one embodiment the method may also be fitting each transmission into a series of frames of Upload Transmissions (‘Up-Link’) and Download Transmissions (‘Downlink’), and transmitting from the SM on any UpLink and from the DAP on any DownLink.

In one embodiment, in the CPDS uplink transmitter shown in FIG. 7, information intended for transmission in a single physical time-frequency dwell of each frame (in accordance with FIG. 6) is first passed through baseband encoding algorithms, e.g., to add medium access control (MAC) and Physical layer (PHY) data bits, perform data encryption and source/channel coding, and interleaving/scrambling operations, convert bits to symbols, and add other PHY signatures (e.g., training preambles and/or Unique Words) as needed/desired to simplify receive processing and/or eliminate processing ambiguities. This process creates baseband source symbol stream $b_S(n_{sym})$ output from the encoder at each symbol index n_{sym} utilized by the transmitter.

The baseband source symbol stream is then passed to the cyclic-prefix direct-sequence (CPDS) spreading processor shown in FIG. 10 (described in detail below), thereby segmenting it into M_{sym} -symbol source data segments and

modulating each source data segment to generate spread source data stream; and outputting $s_S(n_{chip})$ output from the CPDS spreader at each chip index n_{chip} . Taking each $s_S(n_{chip})$ output the method is subsequently pulse-amplitude modulating (PAM) it by a raised-root-cosine (RRC) interpolation pulse; and converting this result to an analog signal-in-space (SiS). This transforms the digital stream to an analog transmission signal by, e.g., using a dual digital-to-analog converter (DAC) applied to the in-phase and quadrature rail (real and imaginary part) of the spread data stream; upconverting this resulting analog SiS to a desired source frequency $f_S(n_{frame})$ selected by the uplink transmitter within time-frame n_{frame} ; and transmitting it at source time $t_S(n_{frame})$ selected by the uplink transmitter within time-frame n_{frame} , at a power level $P_S(n_{frame})$ that is strong enough to allow the intended uplink receiver $l_R(n_{frame})$ to detect, despread, and demodulate the uplink transmission.

As shown in FIG. 8, the source transmit time $t_S(n_{frame})$ and transmit frequency $f_S(n_{frame})$ are preferentially selected randomly within each frame, by randomly selecting dwell index $k_{dwell}(n_{frame})$ for that frame; mapping $k_{dwell}(n_{frame})$ to time slot $k_{slot}(n_{frame})$ and frequency channel $k_{chan}(n_{frame})$, and selecting $t_S(n_{frame})$ from $k_{slot}(n_{frame})$ and $f_S(n_{frame})$ from $k_{chan}(n_{frame})$ via a look-up table. In particular, $k_{dwell}(n_{frame})$ is chosen without any prior scheduling or coordination between the uplink transmitter and the uplink receivers in the network. So the method is selecting randomly the source transmit time and transmit frequency $f_S(n_{frame})$ within each frame, by randomly selecting dwell index $k_{dwell}(n)$ for that frame, without any prior scheduling or coordination between the uplink transmitter and the uplink receivers in the network; mapping $k_{dwell}(n_{frame})$ to time slot $k_{slot}(n_{frame})$ and frequency channel $k_{chan}(n_{frame})$; and selecting $t_S(n_{frame})$ from $k_{slot}(n_{frame})$ and $f_S(n_{frame})$ from $k_{chan}(n_{frame})$ via a look-up table.

Preferentially, in one embodiment, the uplink transmitter also uses knowledge of the range between itself and its nearest physical receiver, e.g., based on known geolocation information of itself and the uplink receivers in its field of view, to provide timing advancement sufficient to allow its transmission to arrive at that receiver at the beginning of its observed uplink subslot. It should be noted that the nearest physical receiver does not need to be the receiver that the uplink transmitter is intending to communicate with. Additionally, this timing advancement does not need to be precise to a fraction of a chip period; however, it should be a small fraction of the cyclic prefix used on the uplink.

Preferentially, in one embodiment, the source transmit power $P_S(n_{frame})$ is calculated using an open-loop algorithm, e.g., by calculating pathloss between each DAP in the SM's field of view during downlink subslots, and using that pathloss estimate to calculate power required to determine the source power required to detect, despread, and demodulate subsequent uplink transmissions. The source transmit power does not need to precisely compensate for the pathloss between the transmitter and receiver, but should have sufficient margin to overcome any effects of fading between the uplink and downlink subslots, including processing gain achievable by the despreader in the presence of credible numbers of other uplink transmissions. Additionally, this power calculation is used to develop a database of candidate uplink receivers to which the transmitter can communicate without violating FCC §15.247 requirements for the 902-928 MHz band.

In alternate embodiments, this algorithm can be improved using closed-loop algorithms that use feedback from the uplink receiver to adjust the power level of the transmitter.

Preferentially, in one embodiment, the closed-loop algorithm should be as simple as possible, in order to reduce vulnerability to "cognitive jamming" measures that can disrupt this feedback loop. However, it should be noted that the blind despreading algorithms employed in one embodiment provide additional protection against cognitive jamming measures even if closed-loop power control is used in the network, due the random and unpredictable selection of frequency channels, time slots, and even intended receivers employed at the uplink transmitter, and due to the ability for the despreading algorithms to adaptively excise CPDS signals received at the uplink and downlink receivers, even if those signals are received at a much higher signal-to-noise ratio (SNR) than the signals intended for the receiver.

In the downlink transmitter shown in FIG. 9, information intended for transmission in each downlink slot of each frame (in accordance with FIG. 6) is passed through baseband encoding algorithms to create baseband source symbol stream $b_S(n_{sym})$; spread using the cyclic-prefix direct-sequence (CPDS) spreading processor shown in FIG. 11 (described in detail below) to generate spread source data stream $s_S(n_{chip})$; pulse-amplitude modulated using a raised-root-cosine (RRC) interpolation pulse; converted to an analog signal-in-space (SiS); upconverted to desired source frequency $f_S(n_{slot})$ selected by the downlink transmitter over time slot; and transmitted over time slot n_{slot} at a source power level P_S that is held constant over every time slot.

Thus the method is: first passing said information through baseband encoding to create a baseband source symbol stream $b_S(n_{sym})$; then passing the baseband source symbol stream $b_S(n_{sym})$ to a cyclic-prefix direct-sequence ('CPDS') spreading means which modulate each data segment to generate the spread source data stream $s_S(n_{chip})$ output from the CPDS spreading means at each chip index n_{chip} ; then subsequently pulse-amplitude modulating the spread source data stream $s_S(n_{chip})$ output by a raised-root-cosine ('RRC') interpolation pulse; converting this result to an analog signal-in-space ('SiS'); upconverting this analog SiS to a desired source frequency $f_S(n_{slot})$ selected by the downlink transmitter over time slot n_{slot} ; and transmitting this analog SiS over the desired source frequency $f_S(n_{slot})$ over time slot n_{slot} at a source power level P_S that is held constant over every time slot.

Preferentially, in one embodiment, each downlink transmitter is synchronized to a common network time-standard, e.g., using synchronization information provided over separate infrastructure, or a GPS time-transfer device. This synchronization should be precise enough to minimize DAP-to-DAP interference, but does not need to be precise to a fraction of a chip period.

Preferentially, in one embodiment, the frequency channel $k_{chan}(n_{slot})$ used to set source frequency $f_S(n_{slot})$ is generated using a pseudorandom selection algorithm based on the slot index n_{slot} and the source index l_S . In other words, the method is selecting a desired source frequency $f_S(n_{slot})$ to be used by the downlink transmitter over time slot n_{slot} by selecting a frequency channel $k_{chan}(n_{slot})$ using a pseudorandom selection algorithm based on the slot index n_{slot} and the source index l_S . In one embodiment, $f_S(n_{slot})$ is known to each downlink receiver allowed to communicate with that transmitter, over at least a subset of slots within each frame. However, in alternate embodiments the downlink receiver may detect the transmit frequency over each slot or a subset of monitored slots and frequency channels, without coordination with the downlink transmitter. Preferentially, in one embodiment, the source frequency employed by each down-

link transmitter is not coordinated with other downlink transmitters in the network; however, in alternate embodiments (employed outside the 902-928 MHz ISM band, which requires uncoordinated hopping between network elements) the downlink transmitters may use the same source frequency in each slot, e.g., to minimize intrusion on out-of-network users of the same frequency band, or may use disjoint source frequencies, e.g., to minimize adjacent-network interference.

In the CPDS uplink spreading structure shown in FIG. 10, the M_{sym} baseband source symbols intended for transmission over time-frame n_{frame} are first passed to a $1:M_{sym}$ serial-to-parallel (S/P) convertor to form $M_{sym} \times 1$ source symbol vector

$$b_S(n_{frame}) = [b_S(n_{frame}M_{sym} + n_{sym})]_{n_{sym}=0}^{M_{sym}-1}.$$

A unique $M_{sym} \times 1$ symbol mask vector

$$m_{RS}(n_{frame}) = [m_{RS}(n_{sym}; n_{frame})]_{n_{sym}=0}^{M_{sym}-1}$$

that is randomly varied from frame to frame is then inserted onto the data (procedure shown in FIG. 12), to provide physical security to the source symbol stream, randomize the source data stream, and allow the intended uplink receiver to differentiate the transmitted signal from other noise, co-channel interference, and in-network signals impinging on that receiver. The symbol mask vector is constructed from the element-wise multiplication of an $M_{sym} \times 1$ source symbol mask vector $m_S(n_{frame})$ (that is unique to the uplink transmitter and randomly varied between time frames), with an $M_{sym} \times 1$ receive symbol mask vector $m_R(n_{frame}; k_{dwell}(n_{frame}))$ (that is randomly varied between time frames and physical dwells and uses a receive symbol mask that is known to the intended receiver and common to every signal attempting to link with that receiver). This operation is depicted in FIG. 10 by the Schur product $m_{RS}(n_{frame}) = m_R(n_{frame}; k_{dwell}(n_{frame})) \circ m_S(n_{frame})$.

In one embodiment, $m_S(n_{frame})$ is either:

known to the receiver, e.g., established during initial and/or periodic network provisioning operations; or a member of a set of sequences that is known to the receiver, e.g., a Zadoff-Chu code with unknown index and/or offset; or

unknown to the receiver but estimable as part of the receive adaptation procedure.

An important member of the last category of source symbol masks is the complex sinusoid given by

$$m_S(n_{sym}; n_{frame}) = \exp\{j2\pi\alpha_S(n_{frame})n_{sym}\}, \quad (\text{Eq2})$$

where $\alpha_S(n_{frame})$ is a cyclic source frequency offset chosen randomly or pseudorandomly over frame n_{frame} . The cyclic source frequency may be communicated to the receiver, or predictable via side information provided at the time of installation of the SM or DAP, providing an additional means for validating the link.

In one embodiment, the source and receive symbol masks each possess a constant modulus, i.e., $|m_{(\cdot)}(n_{sym})| = 1$, to facilitate removal of the symbol mask at the receiver. In addition, except for the complex sinusoidal source symbol mask given in (Eq2), the source and receive symbol masks are preferentially designed to be circularly symmetric, such that the masks have no identifiable conjugate self-coherence

features $\langle m_{(\cdot)}^2(n)e^{-j2\pi\alpha n} \rangle = 0$, and cross-scrambling, such that the cross-multiplication of any two symbol masks results in a composite symbol mask that appears to be a zero-mean random sequence to an outside observer.

In one embodiment, the receive symbol mask is a function of both the time frame index n_{frame} , and the physical dwell index k_{dwell} , is generated using a pseudorandom selection algorithm based on both parameters. In addition, the receive symbol mask can be made unique to each uplink receiver in the network, in which case the receivers can use that mask to identify only those uplink transmitters intending to communicate with that receiver; or it can be made common to every receiver in the network, allowing any receiver to despread any SM in its field of view. The latter property can be especially useful for network access purposes (e.g., using a special receive mask intended just for transmitter association and authentication purposes), and in macrodiverse networks where symbol streams received and/or despread at multiple uplink receivers are further aggregated and processed at higher tiers in the network.

After insertion of the symbol mask, and if observed multipath time dispersion encountered by the channel is a substantive fraction of a single symbol period, a cyclic symbol prefix is then inserted into the $M_{sym} \times 1$ masked symbol vector $d_S(n_{frame})$, such that $d_S(n_{frame})$ is replaced by $N_{sym} \times 1$ data vector

$$d_S(n_{frame}) \leftarrow [d_S((n_{sym} - K_{sym}) \bmod M_{sym}; n_{frame})]_{n_{sym}=0}^{N_{sym}-1}, \quad (\text{Eq 3})$$

where M_{sym} , K_{sym} and $N_{sym} = M_{sym} + K_{sym}$ are the number of encoded symbols, cyclic prefix symbols, and full data symbols transmitted over the frame. The cyclic symbol prefix protects against multipath dispersion with group delay $T_{group} \leq K_{sym} T_{sym}$ observed at the uplink receiver, where $T_{sym} = 1/f_{sym}$ and f_{sym} are the symbol period and symbol rate for the baseband symbol stream, respectively.

After insertion of the symbol mask and (optional) symbol-level cyclic prefix, the full $N_{sym} \times 1$ data vector $d_S(n_{frame})$ is spread by $N_{chp} \times 1$ source spreading code vector $c_S(n_{frame})$, chosen randomly or pseudorandomly over every time frame and not known at the intended receiver. The source spreading code vector also has an optional K_{chp} -chip cyclic chip prefix inserted into it, such that $c_S(n_{frame})$ is given by

$$c_S(n_{frame}) = [c_S((n_{chp} - K_{chp}) \bmod M_{chp}, n_{frame})]_{n_{chp}=0}^{N_{chp}-1}, \quad (\text{Eq 4})$$

$$\text{where } \{c_S(n_{chp}, n_{frame})\}_{n_{chp}=0}^{N_{chp}-1}$$

is an M_{chp} -chip base code used for frame n_{frame} and $N_{chp} = M_{chp} + K_{chp}$. The cyclic chip prefix protects against multipath time dispersion with group delay $T_{group} \leq K_{chp} T_{chp}$ observed at the uplink receiver, where $T_{chp} = 1/f_{chp}$ and f_{chp} are the chip period and chip rate for the baseband symbol stream, respectively.

Preferentially, if the observed multipath time dispersion is a small fraction of a source symbol period, a cyclic chip prefix is inserted into the spreading code and the cyclic symbol prefix is not implemented ($K_{sym} = 0$); or, if the multipath time dispersion is larger than a small fraction of a source symbol period, a cyclic symbol prefix is inserted into the masked data vector and the cyclic chip prefix length is

not implemented ($K_{chp}=0$). In one embodiment, and for the long-range M2M network depicted in FIG. 5 and the 902-928 MHz deployment band and time-frequency framing shown in FIG. 6, a nonzero cyclic chip prefix is inserted into the spreading code and the cyclic symbol prefix is disabled. However, addition of both cyclic prefixes is not precluded by the embodiments in the present description and, in one embodiment, may be advantageous in some applications, e.g., mesh networks where transmitters may be communicating to a nearby receiver over one subset of physical dwells in one frame, and to a remote receiver over a second subset of physical dwells in another frame.

In one embodiment, a modulation-on-symbol direct-sequence spread spectrum (MOS-DSSS) method, in which the spreading code is repeated over every baseband symbol within each hop, is used to spread the source symbol vector $d_S(n_{frame})$ using the spreading code $c_S(n_{frame})$. Mathematically, the spreading operation can be expressed as a matrix inner-product operation given by

$$S_S(n_{frame})=c_S(n_{frame})d_S^T(n_{frame}), \quad (\text{Eq5})$$

in which $c_S(n_{frame})$ and $d_S(n_{frame})$ are the “inner” and “outer” components of the spreading process, respectively, followed by a matrix-to-serial or “matrix flattening” operation to convert the $N_{chp} \times N_{sym}$ data matrix $S_S(n_{frame})$ resulting from this operation to a $(N_{chp}N_{sym})$ -chip scalar data stream $s_S(n_{chp})$, in which each column of $S_S(n_{frame})$ is serially converted to a scalar data stream, moving from left to right across the matrix. An alternative, but entirely equivalent, representation can be obtained using the Kronecker product operation

$$s_S(n_{frame})=d_S(n_{frame}) \otimes c_S(n_{frame}), \quad (\text{Eq6})$$

to generate $(N_{chp}N_{sym}) \times 1$ data vector $s_S(n_{frame})$, followed by a conventional $(N_{chp}N_{sym}):1$ parallel-to-serial (P/S) conversion to $s_S(n_{chp})$. The symbol stream may be real or complex, depending on the baseband source stream, and on the specific spreading code and symbol mask employed by the CPDS spreader.

The CPDS downlink spreading operations shown in FIG. 11 are identical to the CPDS uplink spreading operations shown in FIG. 10, except that data is transmitted every slot rather than every frame, and the symbol mask and source spreading code are also generated every slot rather than every frame. In addition, the specific modulation parameters used at the uplink and downlink spreaders are different,

based on the group delay and interference density observed by the uplink and downlink receivers. In particular, the uplink receivers are expected to observe a large number of uplink emitters on each time slot and frequency channel, whereas the downlink receivers are expected to observe a small number of downlink emitters—typically one-to-two if source frequencies are not coordinated between those emitters. In addition, in one embodiment the uplink transmitters advance their transmit timing to minimize group delay at the uplink receivers in the network, whereas the downlink transmitters are synchronized to emit over coordinated transmission times to minimize overlap between downlink-to-uplink interference between widely-separated (but still visible) downlink transmitters in the network.

As shown in FIG. 12, the symbol mask is preferentially applied, in one embodiment, directly to the $M_{sym} \times 1$ source symbol vector b_S , i.e., in the ‘time domain,’ if a cyclic symbol prefix is not applied at the transmitter ($K_{sym}=0$), or is applied to the $M_{sym} \times 1$ discrete Fourier transform (DFT) of the source symbol vector B_S , i.e., in the ‘frequency domain,’ if a cyclic symbol prefix is applied at the transmitter ($K_{sym}>0$). In both cases, the mask is applied to the appropriate symbol vector using an element-wise multiply or Schur product operation. If the mask is applied in the frequency domain, the resultant masked symbol vector is then converted back to the time domain using an inverse DFT (IDFT) operation. The DFT and IDFT operations can be implemented in a number of ways, including fast Fourier transform (FFT) and inverse-FFT (IFFT) methods that minimize complexity of the overall masking operation. In addition, in some applications, the baseband source vector may be generated directly in the frequency domain and the initial DFT operation can be dispensed with, resulting in an effective OFDM modulation after the IDFT and cyclic symbol prefix operations are applied to the masked source vector.

Table 1 lists the exemplary uplink (UL) and downlink (DL) parameter values used for deployment of this structure in the 902-928 MHz ISM band using one embodiment, which are further illustrated in FIG. 13 for the CPDS uplink, and FIG. 14 for the CPDS downlink. These parameters reflect the different transmission characteristics between the uplink and downlink time slots, as well as constraints imposed by transmission within the 902-928 MHz ISM band.

TABLE 1

Exemplary Uplink and Downlink CPDS PHY, Transceiver Parameters			
Parameter	UL Value	DL Value	Comments
PHY symbols/slot (M_{sym})	480 symbols	384 symbols	
Cyclic symbol prefix length (K_{sym})	0 symbols	3 symbols	Symbol-level cyclic prefix
Full baseband symbols/slot (N_{sym})	480 symbols	387 symbols	
PHY baseband symbol rate (f_{sym})	16 symbol/ms	40 symbol/ms	Rate over Tx interval
Active link duration	30 ms	9.675 ms	
Guard time, end of link slot	75 μ s	250 μ s	40 ms hop dwell time
Spreading code base length (M_{chp})	16 chips	8 chips	
Cyclic chip prefix length (K_{chp})	4 chips	0 chips	Chip-level cyclic prefix
Full spreading code length (N_{chp})	20 chips	8 chips	
Spread chip rate	320 chip/ms	320 chip/ms	$\sim 3.125 \mu$ s chip period
Composite cyclic prefix duration	12.5 μ s	75 μ s	Max multipath dispersion
Equivalent range (4/3 Earth)	3.75 km	22.5 km	UL timing advance needed
RRC rolloff factor	25%	25%	320 kHz HPBW, 400 kHz full BW
Allowed FOA uncertainty	± 50 kHz	± 50 kHz	>50 ppm LO offset, 902-928 MHz band
Frequency channel bandwidth	500 kHz	500 kHz	Compliant, FCC §15.247, ¶(a)(1)(ii)

TABLE 1-continued

Exemplary Uplink and Downlink CPDS PHY, Transceiver Parameters			
Parameter	UL Value	DL Value	Comments
Number hop channels	50 channels	50 channels	Compliant, FCC §15.247, ¶ (a)(1)(ii)
Full hop bandwidth	25 MHz	25 MHz	
Number transmit hops/node	1	1	Compliant, FCC §15.247, ¶ (a)(1)(i)
Number receive hops/node	50 hop	≥1 hop	DAP's receive all UL hops
TDD slots per frame	100 slots	100 slots	4 second frame length
Slot Tx per node each frame	1	100	DL Tx every slot
Hop rate each slot direction	0.25 hps	25 hps	
Average time occupancy over 10 s	6 ms/SM	0.2 ms/DAP	Compliant, FCC §15.247, ¶ (a)(1)(i)
Max Tx conducted power into ANT	30 dBm (1 W)	30 dBm (1 W)	Compliant, FCC §15.247, ¶ (b)(2)
Number Tx ANT's	1 ANT	1 ANT	SISO links assumed
Tx ANT max directivity	6 dBi (4 W EIRP)	6 dBi (4 W EIRP)	Compliant, FCC §15.247, ¶ (b)(4)

20

FIG. 15 shows a CPDS-enabled network element with a real-world, random-number, sourcing-sensor element that provides a truly random kernel input from a sourcing sensor using real-world chance events from which the source spreading code is generated randomly over every transmit opportunity n_{dwell} (every frame on the uplink, and every time slot on the downlink) in a randomizer element and then provided to the CPDS spreader. This is one means whereby the embodiments in the present description can provide physical, or 'reality-based' security rather than algorithmic or model-based security to the M2M network, which cannot be predicted by any intruder attempting to intercept and/or spoof transmission in that network. Moreover, because this source spreading code is generated without any provisioning from the network, this network element eliminates transference of network information (e.g., secure keys used to generate unique spreading codes) that can be intercepted, exploited, and subverted by intruder devices; eliminates network downloading required to transport such information; and eliminates need to manage dissemination of that information at higher tiers in the M2M network.

FIG. 16 shows a CPDS-enabled network element with a real-world, random-number, sourcing-sensor element that provides a truly random kernel input from a sourcing sensor using real-world chance events from which the physical dwell index (time slot and frequency channel) is generated randomly over every time frame in a randomizer element and then provided to the CPDS uplink transmitter. This is a second means whereby the embodiments in the present description can provide physical, or 'reality-based' security rather than algorithmic, model-based, or security to the M2M network, which cannot be predicted by any intruder attempting to intercept and/or spoof uplink transmissions in that network. Because the uplink dwell index is generated without any provisioning from the network, this network element again eliminates transference of network information that can be intercepted, exploited, and subverted by intruder devices; eliminates network downloading required to transport such information; and eliminates the need to manage dissemination of that information at higher tiers in the M2M network. Moreover, because the uplink receiver can unambiguously determine the physical dwell employed in each uplink transmission, if the dwell-generating random seed element is combined with elements deterministically tied to the transmitter, e.g., trusted encryption keys known only to the M2M network, this network element can be used

to further increase the likelihood of detecting network intruders that lack access to that trusted information.

FIG. 17 shows a CPDS-enabled network element with a real-world, random-number, sourcing-sensor element that provides a truly random kernel input from a sourcing sensor using real-world chance events from which elements of the source symbol mask, e.g., a cyclic source frequency offset, are generated randomly over every time frame in a randomizer element and then provided to the CPDS uplink spreader. This is a third means whereby the embodiments in the present description can provide physical, or 'reality-based' security rather than algorithmic or model-based security to the M2M network, which cannot be predicted by any intruder attempting to intercept and/or spoof uplink transmissions in that network. Moreover, because those symbol mask elements are generated without any provisioning from the network, this network element again eliminates transference of network information that can be intercepted, exploited, and subverted by intruder devices; eliminates network downloading required to transport such information; and eliminates need to manage dissemination of that information at higher tiers in the M2M network.

FIG. 18 shows a CPDS-enabled network element with a real-world, random-number, sourcing-sensor element that provides a truly random kernel input from a sourcing sensor using real-world chance events from which the intended uplink receiver is selected randomly from a set of candidate uplink receivers over every time frame in a randomizer element and then provided to the CPDS uplink spreader. This is a fourth means whereby the embodiments in the present description can provide physical, or 'reality-based' security rather than algorithmic or model-based security to the M2M network, which cannot be predicted by any intruder attempting to intercept and/or spoof uplink transmissions in that network. In addition, if a unique pseudo-random receive symbol mask is used at each uplink receiver in the network, this provides multiple additional means whereby the embodiments in the present description can provide physical security to the M2M network, by providing an additional unpredictable search dimension to any algorithm an intruder might use to "crack" the pseudorandom receive symbol mask; and, if the receive symbol masks have been compromised, by increasing the number of unpredictable symbol masks that the intruder must employ to intercept any uplink transmission. Lastly, because the network can unambiguously determine the intended receiver in the

network, if the receiver-generating random seed element is combined with elements deterministically tied to the transmitter, e.g., trusted encryption keys known only to the M2M network, this network element can be used to further increase the likelihood of detecting network intruders that lack access to that trusted information.

As shown in FIG. 19, at the CPDS uplink receiver used in the long-range M2M network embodiment, the incoming received signal-in-space $\tilde{x}_R(t)$ is coupled into the receiver antenna(e), amplified and down-converted from the analog incoming waveforms, digitized using analog-to-digital conversion (ADC) devices, and demultiplexed (DMX'd) into physical dwells, i.e., separated into individual time slots and frequency channels accessible to the receiver, using digital signal processing methods and hardware. These operations result in demultiplexer output signal sequence

$$\{x_R(n_{smp}; n_{frame}, k_{dwell})\}_{n_{smp}=0}^{N_{smp}N_{sym}-1},$$

where receive spreading factor N_{smp} is the number of time samples per source symbol period at the demultiplexer output sampling rate. Note that this sampling rate can be substantively different than the chip rate employed at the transmitter; for example, if the transmitter chip rate is 320 chips/ms and the demultiplexer output rate is 400 samples/ms, then the source spreading factor employed at the transmitter $N_{chp}=16$, but the receive spreading factor is $N_{smp}=20$. Similarly if the cyclic chip prefix employed at the transmitter is $K_{chp}=4$, encompassing a 12.5 μ s time duration, then the cyclic chip prefix covering the same time duration at the receiver is $K_{smp}=5$.

Each demultiplexed physical dwell of interest to the receiver is then passed through an uplink CPDS despreader (shown in FIG. 21), modified with a feedback loop through an adaptation algorithm, which detects and estimates the frequency offset observed by the receiving machine (including a cyclic source frequency offset if that is applied at the uplink transmitter(s)) all sources intended for the receiver; despreads and substantively separates those signals from each other, creating symbol streams with relatively high signal-to-interference-and-noise ratio (SINR) relative to the incoming signal streams, except for gain, phase and frequency offset still present on those symbol streams; and substantively excises signals not intended for the receiver. The resultant substantively separated symbol streams are then fed through to a symbol demodulator that substantively removes the residual gain, phase and frequency offset (using frequency offset estimates also provided by the adaptation algorithm), and removes additional environmental delay/degradation effects actually observed by the receiving machine.

As shown in FIG. 20, the reception operations performed at the CPDS downlink receiver in one embodiment are substantively similar to the CPDS uplink reception operations shown in FIG. 19, except that the dwell DMX operation, used at the uplink receiver to detect and despread large numbers of incoming uplink transmissions, is replaced by a frequency-hopping receiver that demodulates the specific narrowband frequency channel containing the downlink transmission of interest to the receiver over at least a subset of time slots, and which is known to the downlink receiver over those time slots. Alternately, depending on time-criticality of information incoming from the downlink transmitter(s), the downlink receiver can randomly 'scan' over each frequency channel, or 'camp' on a particular frequency

channel or subset of channels with known favorable path-loss, and simply detect, despread, and demodulate transmissions as they arrive on that channel. This alternate approach is particularly well suited for applications or services where an SM does not require acknowledgement of its transmissions, e.g., data transport under User Datagram Protocol (UDP), and is particularly well enabled by the low level of network provisioning required by the embodiments in the present description.

As shown in FIG. 21, if the symbol mask is applied to the baseband source data in the time domain as shown in the upper mask insertion path in FIG. 12, demultiplexed dwell k_{dwell} is despread over time frame n_{frame} by the sequential steps of:

Organizing the demultiplexer output signal sequence

$$\{x_R(n_{smp}; n_{frame}, k_{dwell})\}_{n_{smp}=0}^{N_{smp}N_{sym}-1}$$

into $N_{smp} \times N_{sym}$ matrix $X_R(n_{frame}, k_{dwell})$, where N_{sym} is the number of transmitted symbols in the dwell, and removing the cyclic chip prefix and (if applied at the transmitter) the cyclic symbol prefix from that matrix, given in aggregate by

$$X = \begin{pmatrix} x(N_{smp}K_{sym} + K_{smp}) & \dots & x(N_{smp}(N_{sym} - 1) + K_{smp}) \\ \vdots & \ddots & \vdots \\ x(N_{smp}K_{sym} + N_{smp} - 1) & \dots & x(N_{smp}(N_{sym} - 1) + N_{smp} - 1) \end{pmatrix} \quad (\text{Eq 7})$$

for general received data sequence

$$\{x(n_{smp})\}_{n_{smp}=0}^{N_{smp}N_{sym}-1}.$$

Removing the receive symbol mask from $X_R(n_{frame}, k_{dwell})$, using algorithm

$$X_R(n_{frame}, k_{dwell}) \leftarrow X_R(n_{frame}, k_{dwell}) \text{diag}\{m_R^*(n_{frame}, k_{dwell})\} \quad (\text{Eq8})$$

where $m_R(n_{frame}, k_{dwell})$ is the $M_{sym} \times 1$ receive symbol mask vector over dwell k_{dwell} and time frame n_{frame} , and where $\text{diag}\{\bullet\}$ is the vector-to-diagonal matrix conversion operation and $(\bullet)^*$ is the complex conjugation operation.

Computing $L_{port} \times M_{sym}$ despread symbol matrix $\hat{D}_R(n_{frame}, k_{dwell})$, using linear signal separation algorithm

$$\hat{D}_R(n_{frame}, k_{dwell}) = W_R(n_{frame}, k_{dwell}) X_R(n_{frame}, k_{dwell}) \quad (\text{Eq9})$$

where $W_R(n_{frame}, k_{dwell})$ is an $L_{port} \times M_{smp}$ linear combining matrix, computed as part of the adaptation procedure shown in FIG. 23.

Converting the despread symbol matrix $\hat{D}_R(n_{frame}, k_{dwell})$ back to a sequence of $1 \times L_{port}$ despread symbol vectors

$$\{\hat{d}_R(n_{sym}; n_{frame}, k_{dwell})\}_{n_{sym}=0}^{M_{sym}-1}$$

by applying an $M_{sym}:1$ parallel-to-serial (P/S) conversion operation to each column of $\hat{D}_R(n_{frame}, k_{dwell})$.

The despreading operations performed in the downlink CPDS despreader, shown in FIG. 22, are substantively

equivalent to those shown in FIG. 21, except that they are only applied to time slots and frequency channels monitored by the downlink receiver.

As shown in FIG. 23, in one embodiment, each dwell of interest to a receiver is then despread in accordance with the uplink despreader structure shown in FIG. 21 at the uplink receiver, and in accordance with the downlink despreader structure shown in FIG. 22 at the downlink receiver. This comprises the following steps and substeps:

1st: Detect all sources intended for the receiver, estimate key parameters of those signals, and develop linear combining weights that can substantively despread the source symbols, by:

- 1.A computing the QR decomposition (QRD) of the $M_{smp} \times M_{sym}$ received signal X_R , resulting after removal of cyclic prefix(es) and the receive symbol mask;
- 1.B generating an SINR/carrier revealing feature spectrum that can (i) estimate the maximum attainable despread signal-to-interference-and-noise ratio ('maximum despread SINR') of each signal impinging on the receiver that is employing the receive symbol mask ('authorized signals'), given the received spreading code (source spreading code, modulated by the transmission channel) of each signal and interference impinging on the receiver at the dwell and time-frame being monitored by the receiver, (ii) as a function of observed frequency offset of that signal, and (iii) provide statistics that can be used to develop linear combining weights that can substantively achieve that maximum SINR, without knowledge of the received spreading code for any of those signals, and without knowledge of the background noise and interference environment;
- 1.C detecting L_{port} significant peak(s), in the SINR/carrier revealing feature spectrum, and determining the maximum despread SINR and frequency offset of each peak;
- 1.D refining strengths (estimated maximum despread SINR) and locations (estimated frequency offsets) of each significant peak, e.g., using Newton search methods; and
- 1.E developing $L_{port} \times M_{sym}$ linear combiner weight matrices W_R that can substantively achieve the maximum despread SINR for each authorized signal, without knowledge of the received spreading code for any of those signals, and without knowledge of the background noise and interference environment.

Then:

2nd: Despread and demodulate the detected sources:

- 2.A Despread detected source symbols—separate authorized signals employing the receive symbol mask, and automatically excise unauthorized signals not employing that mask;
- 2.B Substantively remove frequency offset from the despread symbols, using the frequency offset estimates;
- 2.C Estimate and correct phase offsets, and further refine frequency offsets to algorithm ambiguity using known features of the source symbols, e.g., adherence to known symbol constellations, unique words (UW's) and training sequences embedded in the source symbols, known properties of the source symbol mask, etc.;
- 2.D Remove algorithm ambiguity using additional features of the source symbols, e.g., UW's, forward error correction (FEC), cyclic redundancy check's (CRC's), etc.; and
- 2.E Decrypt traffic and protected medium access control (MAC) data.

Then:

3rd: Perform ancillary processing as needed/appropriate:

- 3.A Compute received incident power (RIP) for open-loop power control, using SINR and channel estimates provided by the CPDS despreading algorithm (uplink receiver);
- 3.B Correlate source internals, externals with trusted information, using dwell, intended receiver and source symbol mask elements provided by the CPDS receiver and despreading algorithm; and
- 3.C Detect network intrusions—revise symbol masks if needed (downlink receiver);

In one embodiment, specific partially or fully-blind adaptation algorithms can meet the criteria described above include:

The FFT-enabled least-squares (FFT-LS) detection, carrier estimation, and signal extraction algorithm, which can be derived as a maximum-likelihood estimate of carrier frequency for signals with known content but unknown carrier offset which exploits known training signals inserted in the baseband symbol sequence at every source (e.g., in "Unique Word" fields, or more sophisticated embedded pilots) to determine the linear combining weights. FFT-LS is most useful at high symbol rates (>3 bits/symbol), as the high dimensionality of the CPDS linear combiner requires a large set-aside of non-information-bearing symbols for training purposes (e.g., ≥ 40 UL symbols, e.g., 8% of each slot, for the baseline uplink signal).

The auto-self-coherence-restoral (A-SCORE) algorithm described in, which exploits nonzero (by design, perfect) temporal correlation induced as part of the embedded invariance algorithm. A-SCORE is most useful at moderate symbol rates (<3 bits/symbol), and over data bursts that are too short to allow set-aside for long training sequences (e.g., greater than 30% of the source symbols at 3 bits/symbol, or greater than 20% of the source symbols at 1 bit/symbol).

The conjugate self-coherence restoral (C-SCORE) algorithm, which exploits nonzero conjugate self-coherence of the baseband symbol sequence, if it exists prior to application of the masking signal, and which estimates the twice-carrier rate of that signal (including any cyclic source frequency offset applied to the source symbol mask). C-SCORE is most useful for symbol streams with perfect conjugate self-coherence, e.g., binary phase-shift keyed (BPSK) and amplitude-shift keyed (ASK) symbol sequences.

All of these algorithms are blind despreading methods that do not require knowledge of the spreading code to adapt the despreader. Moreover, except for incorporation of structure to resolve known ambiguities in the despreader output solutions, C-SCORE and A-SCORE are fully-blind despreading methods that require no knowledge of the source symbol sequence, and use the entire symbol stream to adapt the despreader. All of these methods also asymptotically converge to the max-SINR solution over data bursts with high usable time-bandwidth product (M_{sym}/M_{smp} large, where M_{sym} is the number of symbols used for training purposes). Moreover, all of the receiver adaptation algorithms are assumed to operate on a slot-by-slot basis, such that despreader weights for each slot are computed using only data received within that slot. Lastly, all of these methods yield an SINR-like feature spectrum which can be used to detect and estimate the carrier offset of the symbol sequences to within a Nyquist zone ambiguity, i.e., carrier

mod symbol rate for FFT-LS and A-SCORE, and twice-carrier mod symbol rate for C-SCORE.

In one embodiment, the baseband source sequence is BPSK and therefore possesses a perfect conjugate self-coherence at its twice-frequency offset. Moreover, if the symbol masks applied at the spreader are circularly symmetric, the received symbol streams have no identifiable conjugate self-coherence prior to the symbol demasking operation. After the demasking operation, the symbols employing that mask, and only the symbols employing that mask, are converted to perfectly conjugate self-coherent signals that provide strong peaks at their twice-carrier frequencies. As a consequence, the despreader is ideally suited for adaptation using a C-SCORE algorithm.

The full C-SCORE method is described as follows:

Compute the Q component Q_R of the QRD of X_R^T using a modified Gram-Schmidt orthogonalization (MGSO) algorithm

Compute $\{S_R(\alpha_k)\}$ from Q_R at uniform trial frequencies $\{\alpha_k\} = \{2\pi k/K_{DFT}\}_{k=0}^{K_{DFT}-1}$ using a fast Fourier transform (FFT) algorithm,

$$\{(S_R(\alpha_k))_{m,m'}\} = DFT_{K_{FFT}}\{(q_R(n))_m(q_R(n))_{m'}\}, \quad (\text{Eq 10})$$

$$\begin{cases} m = 1, \dots, M_{smp} \\ m' = 1, \dots, m \end{cases}$$

To facilitate subsequent operations, compute and store the $\frac{1}{2}M_{smp}(M_{smp}+1)M_{sym}$ unique cross-multiplications used in (Eq10) prior to the FFT operation. These cross-multiplications can also be used to compute (Eq10) for other masks.

Initialize $u_1(\alpha_k) = e_{M_{smp}}(M_{smp})$, and estimate $\{\eta_1(\alpha_k), u_1(\alpha_k)\}$ using power method recursion

$$u_1(\alpha_k) \leftarrow S_R(\alpha_k)u_1(\alpha_k)$$

$$u_1(\alpha_k) \leftarrow S_R^H(\alpha_k)u_1(\alpha_k)$$

$$\eta_1(\alpha_k) = \|u_1(\alpha_k)\|_2$$

$$u_1(\alpha_k) \leftarrow u_1(\alpha_k)/\eta_1(\alpha_k). \quad (\text{Eq11})$$

Select the L_{port} strongest peaks in $\{\eta_1(\alpha_k)\}$, $L_{port} = M_{smp}$. Estimate the dominant mode $\{\eta_1(\hat{\alpha}), u_1(\hat{\alpha})\}$ of $S(\hat{\alpha})$ at each peak frequency $\hat{\alpha}$, and optimize the frequency location to subbin accuracy, using an alternating projections method that alternately optimizes $\{\eta_1(\hat{\alpha}), u_1(\hat{\alpha})\}$ given fixed $\hat{\alpha}$ using (Eq11), and optimizes $\hat{\alpha}$ to maximize $\text{Re}\{u_1^T S_R(\hat{\alpha})u_1\}$ given fixed u_1 using a Newton recursion. This processing step reuses the cross-multiplication products computed in (Eq10).

Estimate the maximum attainable signal-to-interference-and-noise ratio (SINR) of the despreader at peak $\hat{\alpha}$ using $\hat{\gamma}_{max}(\hat{\alpha}) = \eta_1(\hat{\alpha})/(1 - \eta_1(\hat{\alpha}))$ and thin the C-SCORE peaks if needed.

Compute the spatially whitened minimum mean-square error (MMSE) weights using the formula

$$g(\hat{\alpha}) = \sqrt{\hat{\gamma}_{max}(\hat{\alpha})(1 + \hat{\gamma}_{max}(\hat{\alpha}))} e^{-j\frac{1}{2}L_u^T(\hat{\alpha})S(\hat{\alpha})u_1(\hat{\alpha})} \quad (\text{Eq 12})$$

$$u_R(\hat{\alpha}) = g(\hat{\alpha})u_1(\hat{\alpha})$$

Despread the symbol stream using $\hat{d}_R(\hat{\alpha}) = Q_R u_R(\hat{\alpha})$, and P/S convert to scalar stream $\hat{d}_R(n_{sym}; \hat{\alpha})$.

Remove the carrier offset using $\hat{d}_S(\hat{\alpha}) = \Delta(\hat{\alpha})\hat{d}_R(\hat{\alpha})$, where

$$\Delta(\hat{\alpha}) = \text{diag}\{e^{-j2\pi\hat{\alpha}n_{sym}}\}_{n_{sym}=0}^{M_{sym}-1}.$$

Use additional source signal structure to resolve the $\pm(\pm 1)^{n_{sym}}$ amplitude ambiguity inherent to the algorithm, e.g., using a Unique Word inserted into the symbol stream, and convert $\hat{\alpha}$ to a true carrier offset (mod the symbol rate).

Optionally refine the carrier, despreading weights, and source symbol stream using decision-direction recursion

$$\hat{d}_R(\hat{\alpha}) = Q_R u_R(\hat{\alpha}) \quad (\text{Eq 13})$$

$$\hat{d}_S(\hat{\alpha}) = \text{sgn}\{\text{Re}\{\Delta(\hat{\alpha})\hat{d}_R(\hat{\alpha})\}\},$$

$$\Delta(\hat{\alpha}) = \text{diag}\{e^{-j2\pi\hat{\alpha}n_{sym}}\}_{n_{sym}=0}^{M_{sym}-1}$$

$$\hat{\alpha} = \underset{\alpha}{\text{argmax}} \|u_R(\hat{\alpha})\|_2^2,$$

$$u_R(\hat{\alpha}) = Q_R^H \Delta^*(\hat{\alpha})\hat{d}_S(\hat{\alpha}),$$

where the carrier estimate and despreading weights are jointly updated using a Newton recursion.

The C-SCORE algorithm generates a single feature spectrum with multiple peaks at twice the carrier (mod the symbol rate) of every source communicating with the receiver, and with peak strengths consistent with the maximum attainable SINR of the despreader. Random cyclic complex sinusoids are also completely transparent to the C-SCORE algorithm, as the complex sinusoid may simply shift the location of peaks in the feature spectrum. This may improve resistance to collisions, by randomizing the location of all of the peaks in the spectrum. This can also provide additional resistance to spoofing if the cyclic offset used by each source is partially or fully derived from information known only to the source and receiver.

If a cyclic symbol prefix is inserted into the baseband symbol vector at the transmitter, and the operations shown on the lower branch of FIG. 12 are used to insert the symbol mask at the transmitter, then the alternate ‘frequency domain’ despreading structure shown in FIG. 24 can be employed to despread the received signal dwells. In this despreader, the input signal sequence

$$\{x_R(n_{smp})\}_{n_{smp}=0}^{N_{smp}N_{sym}}$$

is first converted to a $N_{smp} \times N_{sym}$ vector using a $1:N_{smp}$ serial-to-parallel converter, and the first K_{sym} symbols ($N_{smp}K_{sym}$ samples) encompassing the cyclic symbol prefix are removed. The resulting $N_{smp} \times M_{sym}$ data vector is then passed through an $N_{smp} \times M_{sym}$ -point DFT, reshaped into an $N_{smp} \times M_{sym}$ matrix, and transposed to form $M_{sym} \times N_{smp}$ matrix

$$X_R = [X_R(:, k_{sym})]_{k_{sym}=0}^{M_{sym}-1},$$

where k_{sym} is the index for each column of X_R . The receive symbol mask is then removed from X_R using (Eq8), and

each column of X_R is despread using linear combining algorithm

$$\hat{D}_R(:,k_{sym})=W_R(k_{sym})X_R(:,k_{sym}) \quad (\text{Eq14})$$

where

$$\{W_R(k_{sym})\}_{k_{sym}=0}^{M_{sym}-1}$$

are a set of $M_{sym} \times L_{port} \times M_{smp}$ linear combining matrices, computed as part of an adaptation procedure, and individually applied to each column of X_R . Each row of the resultant $L_{port} \times M_{sym}$ despread data matrix \hat{D}_R is then converted back to the time domain using an M_{sym} -point inverse DFT (IDFT) operation, and converted to a sequence of $L_{port} \times 1$ despread symbol vectors

$$\{\hat{d}_R(n_{sym})\}_{n_{sym}=0}^{M_{sym}-1}$$

It should be noted that any uplink transmitter employing the same receive symbol mask can use that mask to detect and despread emissions from neighboring uplink transmitters. As a consequence, information sent from these transmitters should possess additional encryption to protect that information from eavesdropping by neighboring network members. This can be accomplished at the physical layer, for example by adding a BPSK source symbol mask to each uplink transmission that still allows uplink desreading using C-SCORE; or by adding stronger encryption at higher layers in the OSI protocol stack; or by a combination of both strategies.

It should also be noted that this capability does not compromise ability for the network to defeat man-in-the-middle attacks, as the transmission parameters of the uplink transmitters cannot be predicted. It does place increased importance on truly random choice of those parameters, as an intelligent adversary could eventually learn the keys underlying pseudorandom choices if weak enough.

In fact, this capability can greatly enhance ability for the network to detect intruders, by allowing SM's to measure and transmit observables of their neighbors to the network DAP's as a normal part of their operation. Any intruder attempting to spoof an SM would be instantly identified by virtue of observables of the correct SM reported to the DAP by its neighbors.

For example, an SM can simply pick an uplink dwell to listen on; intercept and demodulate any SM transmissions during that dwell; break out a MAC header containing information sent some a portion of the message known to contain the SM's Address (which might still be encrypted using keys possessed by only the DAP and SM itself), and send that information along with PHY observables of the intercepted SM, e.g., the dwell index, source frequency offset, intercepted frame index, and intended receive DAP (if non-macrodiverse usage) back to a the network in a later transmission. That information alone should be enough to eventually uncover any radio attempting to spoof transmission.

This capability can also greatly facilitate the implementation of mesh networks to further improve reliability of the network, and reduce energy emitted or dissipated by the uplink transmitters.

One embodiment seamlessly extends to additional transceiver and network improvements, including:

Use of spatial and polarization diverse antenna arrays at any node in the network. In this case the spreading code can be repeated or randomly extended over each antenna employed at the transmitter, and the dimensionality of the desreading algorithms is simply multiplied by the number antennas employed at the receiver.

Macrodiverse uplink desreading methods in which part or all of the desreading operations are performed at a higher tier of the network.

Both of the above extensions can be implemented without any substantive change to the transmission and spreading structures described herein, and do not require reciprocity of the uplink and downlink channels or calibration techniques to enforce such reciprocity.

FIG. 25 shows a weakly-macrodiverse uplink desreading method, in which the DAP-specific receive symbol mask is replaced by a common or network-wide receive symbol mask $m_R(n_{frame}, k_{dwell})$, which is used by every SM attempting to transmit over physical dwell k_{dwell} in time frame n_{frame} , and which is assumed to evolve in a pseudorandom manner known to the SM over every frame. Thus the method is using any of the set of common receive symbol mask for that set of DAPs and the set of common receive symbol masks for all DAPs in the network; using as the form for each said common receive symbol mask $m_R(n_{frame}, k_{dwell})$; using this form by every SM attempting to transmit over physical dwell k_{dwell} in time frame n_{frame} ; evolving this form in a pseudorandom manner known to the SM over every frame; and that on receiving and downconverting a symbol stream for any device, uses this form to despread the symbol stream and then passing the symbol stream then on to the respective receiving device.

In more complex systems and other embodiments, this network mask may be broken into geographic-specific zonal masks, in order to differentiate between SM's based on their proximity to different clusters of DAP's. Because the symbol masks do not disrupt the MOS-DSSS structure of the signals, they still allow signals outside that geographical region to be excised by the desreader; however, only the signals within that region may be discovered and extracted by the desreader employed that symbol mask.

The CPDS method is particularly well suited to weakly-macrodiverse combining. The cyclic prefixes provide a high degree of tolerance to timing error between signals received at the DAP's in the network; in fact, it is likely that no timing error may occur at SM's that can most benefit from macrodiverse processing, e.g., SM's that are at nearly-equal range to multiple DAP's, and are therefore received at near-equal RIP at those DAP's. Moreover, because the SM uplink signals are despread at the DAP's, the bulk of operations needed to despread those signals are distributed over the network, with a relatively small number of operations needed at the network level. Lastly, the desreading performed at the DAP's also compress data needed to be transferred to the central site by a factor of 20 at least in one embodiment, much more if the despread symbols are quantized to low precision before being uploading to the central site.

FIG. 26 shows an even more powerful strongly-macrodiverse extension, in one embodiment, in which the entire $M_{smp} \times M_{sym}$ demasked DAP data matrices

$$\{X_R(n_{frame}, k_{dwell}, \ell_R)\}_{\ell_R=1}^{L_R}$$

are uploaded to a central processing site. In this system, the data matrices are “stacked” into an $L_R M_{smp} \times M_{sym}$ network data matrix $X_R(n_{frame}, k_{dwell})$ given by

$$X_R(n_{frame}, k_{dwell}) = \begin{pmatrix} X_R(n_{frame}, k_{dwell}; 1) \\ \vdots \\ X_R(n_{frame}, k_{dwell}; L_R) \end{pmatrix}, \quad (\text{Eq 15})$$

The network data matrix is then passed to a network-level despreader that on receiving and downconverting a symbol stream for any device removes the DAP carrier offsets

$$\{\alpha_R(\ell_R)\}_{\ell_R=1}^{L_R}$$

(if needed); detects the sources

$$\{\ell_S\}_{k'_{dwell}(\ell_S)=k_{dwell}}$$

using that channel; estimates their carrier offsets

$$\{\alpha_S(\ell_S)\}_{k'_{dwell}(\ell_S)=k_{dwell}}$$

develops a set of linear combiner weights with $L_R M_{smp}$ degrees of freedom, and uses those combining weights to extract all of those SM's symbol streams from the network data matrix, to be used by the network.

The macrodiverse extensions can improve the security, efficiency, and complexity of M2M networks, by exploiting the additional route diversity of macrocellular and mesh networks. Large scale network analyses have established that weakly-macrodiverse networks can provide as much as 3 dB of link margin in the long-range M2M use scenario shown in FIG. 5, and the strongly-macrodiverse network can provide much as 12 dB of link margin in the same scenario. This link margin can be traded against transmit power, link data rate, or network density to further improve performance or security of the network. Moreover, both approaches provide inherent resistance to denial-of-service attacks, as an attacker would need to simultaneously attack every uplink receiver in the network to prevent reception of information by a macrodiverse network. In addition, migrating the most computationally complex operations to a central processing node can significantly reduce complexity of the uplink receivers in the network.

FIG. 27 shows an FCC §15.247 compliant time-frequency framing structure for an alternate Frame Synchronous (FS) system embodiment, and for the long-range M2M cell shown in FIG. 5. The FS framing structure is similar to the CPDS framing structure shown in FIG. 6, except in this embodiment the durations of the DL subslots are 9 ms, and the preceding and following guard intervals are each 500 μ s. These much higher guard intervals allows the alternate FS network to be used in applications where the SM's and/or DAP's are communicating over much longer ranges or at much higher altitudes, e.g., in airborne or satellite communication networks. In addition, this frame structure provides sufficient guard interval to eliminate the need for SM timing advancement in many applications; or can be used to pro-

vide additional security to the network, e.g., by adding pseudorandom jitter to the format.

FIG. 28 shows an uplink transmitter structure employing the alternate FS spreading strategy. The transmitter structure is substantively similar to the CPDS uplink transmitter structure shown in FIG. 7, except that the information intended for transmission is first passed through a baseband modulator that generates a baseband data sequence $d_S(n_{DAC})$ with arbitrary modulation format, and with a sample rate equal to the interpolation rate of the transmitter digital-to-analog convertor(s) (DAC(s)). The baseband data sequence is then separated into segments of data intended for transmission over a single time-frequency dwell within each frame, and passed to a frame synchronous (FS) spreader that spreads it over time within an uplink dwell subslot, resulting in an FS spreader output signal sequence $s_S(n_{DAC})$ that also has a sample rate equal to the interpolation rate of the transmitter DAC. The FS spreader output signal is then converted to analog format in the transmitter DAC(s), frequency-shifted to RF transmit frequency $f_S(n_{frame})$, amplified to transmit power level $P_S(n_{frame})$, and transmitted to its intended uplink receiver.

In one embodiment, a possible feature of the FS embodiment is its ability to be used with any baseband modulation format. The exemplary FS system described here uses a spectrally efficient OFDM modulation format with a cyclic prefix allowing much higher tolerance to observed group delay at the uplink receiver.

The algorithm used to compute the time-slot start time $t_S(n_{frame})$, frequency channel center frequency $f_S(n_{frame})$, and transmit power level $P_S(n_{frame})$ in each time frame n_{frame} is computed using the operations shown in FIG. 8, and allows fully randomized selection of transmit dwell, $k_{dwell}(n_{frame})$ and intended uplink receiver $l_R(n_{frame})$. However, the large cyclic prefix can obviate the need for the timing advancement operation shown in that Figure, or can be used to further improve physical security of the network by pseudorandomly adjusting $t_S(n_{frame})$ in each time frame, or by pseudorandomly adjusting the duration of each OFDM cyclic prefix before or during the FS spreading operation.

FIG. 29 shows a downlink transmitter structure employing the alternate FS spreading strategy. The transmitter structure is substantively similar to the CPDS downlink transmitter structure shown in FIG. 9, except that the information intended for transmission is also first passed through a baseband modulator that generates a time-slot of baseband data with arbitrary modulation format and sample rate at the presumed interpolation rate of the transmitter DAC(s), whereby it is further spread in time by the FS spreader, resulting in a spreader output signal with the same sampling rate. The FS spreader output signal is then converted to analog format in the transmitter DAC(s), frequency-shifted to RF transmit frequency $f_S(n_{slot})$, amplified to (fixed) transmit power level P_S , and transmitted to its intended downlink receiver. The frequency channel $k_{chan}(n_{slot})$ used to set center frequency $f_S(n_{slot})$ in each time slot is pseudorandomly adjusted based on the time slot index n_{slot} and source index l_S , and is assumed to be known or detectable to intended downlink receivers in the network.

In the FS uplink spreading structure shown in FIG. 30, the N_{DAC} baseband source samples intended for transmission over time-frame n_{frame} are first passed to a $1:N_{DAC}$ serial-to-parallel (S/P) convertor to form $N_{DAC} \times 1$ source symbol vector

$$d_S(n_{frame}) = [d_S(n_{frame}N_{DAC} + n_{DAC})]_{n_{DAC}=0}^{N_{DAC}-1}$$

The source symbol vector is then spread over time using an $N_{chp} \times 1$ spreading code vector $c_{RS}(n_{frame})$ that is randomly or pseudorandomly generated in each time frame. Mathematically, the spreading operation can be expressed as a matrix inner-product operation given by

$$S_S(n_{frame}) = d_S(n_{frame}) c_{RS}^T(n_{frame}), \quad (\text{Eq16})$$

in which $d_S(n_{frame})$ and $c_{RS}(n_{frame})$ are the “inner” and “outer” components of the spreading process, respectively, followed by a matrix-to-serial or “matrix flattening” operation to convert the $N_{DAC} \times N_{chp}$ data matrix $S_S(n_{frame})$ resulting from this operation to a $(N_{DAC}N_{chp})$ -chip scalar data stream $s_S(n_{DAC})$, in which each column of $S_S(n_{frame})$ is serially converted to a scalar data stream, moving from left to right across the matrix. An alternative, but entirely equivalent, representation can be obtained using the Kronecker product operation

$$s_S(n_{frame}) = c_{RS}(n_{frame}) \otimes d_S(n_{frame}), \quad (\text{Eq17})$$

to generate $(N_{DAC}N_{chp}) \times 1$ data vector $s_S(n_{frame})$, followed by a conventional $(N_{DAC}N_{chp}):1$ parallel-to-serial (P/S) conversion to $s_S(n_{DAC})$. The symbol stream may be real or complex, depending on the baseband source stream and the specific spreading code used by the FS spreader.

Comparing (Eq16)-(Eq17) with (Eq5)-(Eq6), the FS spreading operation is seen to be the reverse or ‘dual’ of the spreading operation performed in the CPDS spreader. Alternately, the baseband data modulates the code sequence, that is, the baseband data in the FSS airlink takes on the same function as the spreading code in the CPDS airlink, and vice versa.

In the absence of known and exploitable structure of the baseband source vector, the spreading code $c_{RS}(n_{frame})$ is constructed from the element-wise multiplication of an $N_{chp} \times 1$ source spreading code vector $c_S(n_{frame})$ that is unique to the uplink transmitter and randomly varied between time frames, with an $N_{chp} \times 1$ receive spreading vector $c_R(n_{frame}; k_{dwell}(n_{frame}))$ that is randomly varied between time frames and physical dwells. This operation is depicted in FIG. 30 by the Schur product $c_{RS}(n_{frame}) = c_R(n_{frame}; k_{dwell}(n_{frame})) \circ c_S(n_{frame})$.

In other embodiments, in the absence of known and exploitable structure of the baseband source vector, $c_S(n_{frame})$ is further either:

- known to the receiver, e.g., established during initial and/or periodic network provisioning operations; or
- a member of a set of sequences that is known to the receiver, e.g., a Zadoff-Chu code with unknown index and/or offset; or
- unknown to the receiver but estimable as part of the receive adaptation procedure, e.g., a complex sinusoid given by

$$c_S(n_{frame}) = [\exp\{j2\pi\alpha_S(n_{frame})n_{chp}\}]_{n_{chp}=0}^{N_{chp}-1}, \quad (\text{Eq 18})$$

where $\alpha_S(n_{frame})$ is a cyclic source frequency offset chosen randomly or pseudorandomly over frame n_{frame} .

In the latter case, the cyclic source frequency offset may be communicated to the receiver, or predictable via side information provided at the time of installation of the SM or DAP, providing an additional means for validating the link. Except for the complex sinusoidal frequency offset, the source and receive code spreading vectors are preferentially designed to be circularly symmetric, such that the spreading vectors have no identifiable conjugate self-coherence fea-

tures $\langle c_{(\cdot)}^2(n)e^{-j2\pi\alpha n} \rangle = 0$, and cross-scrambling, such that the cross-multiplication of any two spreading vectors results in a composite spreading vector that appears to be a zero-mean random sequence to an outside observer.

Note that the FS spreader does not insert a ‘symbol mask’ into the spreader input signal—the source spreading code takes on the same function as the receive symbol mask in the FS format. This source frequency offset can also be generated using the symbol mask randomization network element shown in FIG. 17. As in the CPDS spreader, the random cyclic frequency offset provides additional differentiation between co-channel signals, as well as an additional spoof detection if that offset is known, estimable, communicated to the uplink receiver via other means.

If the baseband source signal contains additional known features, e.g., structural embedding taught in U.S. Pat. No. 7,079,480 or embedded pilot signals taught in U.S. Pat. No. 8,363,744, the entire spreading code vector $c_{RS}(n_{frame})$ can be randomly generated, e.g., using the spreading code randomization network element shown in FIG. 15. This can provide additional differentiation between co-channel signals, as well as an additional spoof detection if that offset is known, estimable, communicated to the uplink receiver via other means.

The FS downlink spreading operations shown in FIG. 31 are identical to the FS uplink spreading operations shown in FIG. 30, except that data is transmitted every slot rather than every frame, and the spreading code is also generated every slot rather than every frame. In addition, the specific spreading parameters used at the uplink and downlink spreaders are different, based on the traffic requirements of the uplink and downlink and the durations of the uplink and downlink slots. The baseband modulation formats can also be different in both link directions, or can be exactly the same in order to reduce complexity of the overall system.

Table 2 lists the exemplary uplink (UL) and downlink (DL) parameter values used for deployment of this structure in the 902-928 MHz ISM band using one embodiment, which are further illustrated in FIG. 32 for the FS uplink and FIG. 33 for the FS downlink. These parameters reflect the constraints imposed by transmission within the 902-928 MHz ISM band.

TABLE 2

Exemplary Uplink and Downlink FS PHY, Transceiver Parameters			
Parameter	UL Value	DL Value	Comments
Subcarriers/symbol (N_{sym})	480 symbols	480 symbols	
Subcarrier separation	800 kHz	800 kHz	1.25 ms FFT duration
Symbol cyclic prefix	250 μ s	250 μ s	1.5 ms OFDM symbol
Equiv. range (4/3 Earth)	75 km	75 km	Timing advance unneeded

TABLE 2-continued

Exemplary Uplink and Downlink FS PHY, Transceiver Parameters			
Parameter	UL Value	DL Value	Comments
Spread code length (N_{chp})	20 chips	6 chips	Cyclic chip prefix unneeded
Active link duration	30 ms	9 ms	
Baseband symbol rate (f_{sym})	16 symbol/ms	53.33 symbol/ms	
Guard time, end of link slot	500 μ s	500 μ s	
OFDM bandwidth	384 kHz	384 kHz	
Allowed FOA uncertainty	± 50 kHz	± 50 kHz	>50 ppm LO offset, 902-928 MHz band
Hop dwell bandwidth	500 kHz	500 kHz	Compliant, FCC §15.247, ¶(a)(1)(ii)
Number hop channels	50 channels	50 channels	Compliant, FCC §15.247, ¶(a)(1)(ii)
Full hop bandwidth	25 MHz	25 MHz	
Number transmit hops/node	1 hop Tx/SM	1 hop Tx/DAP	Compliant, FCC §15.247, ¶(a)(1)(i)
Number receive hops/node	50 hop Rx/DAP	≥ 1 hop Rx/SM	DAP's can receive all UL's
TDD slots per frame	100 slots	100 slots	4 second frame length
Slot Tx/node each frame	1	100	DAP Tx every slot, SM Tx once per frame
Hop rate each slot direction	0.25 hps	25 hps	
Average time occupancy over 10 s	6 ms/SM	0.2 ms/DAP	Compliant, FCC §15.247, ¶(a)(1)(i)
Max Tx conducted power into ANT	30 dBm (1 W)	30 dBm (1 W)	Compliant, FCC §15.247, ¶(b)(2)
Number Tx ANT's	1 ANT	1 ANT	SISO links assumed
Tx ANT max directivity	6 dBi (4 W EIRP)	6 dBi (4 W EIRP)	Compliant, FCC §15.247, ¶(b)(4)

The parameters shown in Table 2 are similar in many respects to those shown in Table 1 for the CPDS spreader, but also possess important differences. In particular, the exemplary FS spreader employs an OFDM baseband modulation format with the same number of subcarriers, cyclic prefix, subcarrier frequency spacing, and baseband information rate on each side of the link, and the exemplary FS spreader does not require timing advancement at the uplink transmitters. This can reduce the complexity of the FS transceivers, as the substantively similar processing hardware and software can be used to implement the FS transmitter and receiver at both ends of the link, and allows the FS transceivers to be used in networks with extreme long range, e.g., airborne and satellite communication networks.

The FS uplink receiver shown in FIG. 34 is substantively similar to the CPDS uplink receiver shown in FIG. 19, except that each received dwell is despread in an FS despreader rather than a CPDS despreader, resulting in $L_{port} \times 1$ vector FS despreader output signal sequences

$$\{y_R(n_{smp}; n_{frame}, k_{dwell})\}_{n_{smp}=0}^{N_{smp}-1},$$

comprising the L_{port} signals that are intended for the uplink receiver over dwell k_{dwell} and time frame n_{frame} , and that have been substantively extracted from received environment by the FS despreader; and except for the baseband demodulator that demodulates the resultant substantively extracted baseband signals provided by the despreader. The baseband source signals transmitted from the uplink transmitters must contain sufficient information to remove any ambiguities remaining in the despreader output signals.

Similarly, in another embodiment, the FS downlink receiver shown in FIG. 35 is substantively similar to the CPDS downlink receiver shown in FIG. 21, except that each received dwell is despread in an FS despreader rather than a CPDS despreader, resulting in $1 \times L_{port}$ vector FS despreader output signal sequences

$$\{y_R(n_{smp}; n_{slot})\}_{n_{smp}=0}^{N_{smp}-1},$$

comprising the L_{port} signals that are intended for the downlink receiver over time slot n_{slot} and that have been substantively extracted from received environment by the FS despreader; and except for the baseband demodulator that demodulates the resultant substantively extracted baseband signals provided by the despreader. The baseband source signals transmitted from the uplink transmitters must contain sufficient information to remove any ambiguities remaining in the despreader output signals.

As shown in FIG. 36, at the uplink despreader, dwell k_{dwell} is despread over time frame n_{frame} by the sequential steps of:

Organizing the demultiplexer output signal sequence

$$\{x_R(n_{smp}; n_{frame}, k_{dwell})\}_{n_{smp}=0}^{N_{smp}N_{chp}-1}$$

into $N_{smp} \times N_{chp}$ matrix $X_R(n_{frame}, k_{dwell})$ where N_{smp} is the number of received baseband samples per chip in the dwell at the demultiplexer output sampling rate, given by

$$X = \begin{pmatrix} x(0) & \cdots & x(N_{smp}(N_{chp} - 1)) \\ \vdots & \ddots & \vdots \\ x(N_{smp} - 1) & \cdots & x(N_{smp}(N_{chp} - 1) + N_{smp} - 1) \end{pmatrix} \quad (\text{Eq 19})$$

for general received data sequence

$$\{x(n_{smp})\}_{n_{smp}=0}^{N_{smp}N_{chp}-1}.$$

Removing the receive spreading code from $X_R(n_{frame}, k_{dwell})$, using algorithm

$$X_R(n_{frame}, k_{dwell}) \leftarrow X_R(n_{frame}, k_{dwell}) \text{diag}\{c_R^*(n_{frame}, k_{dwell})\} \quad (\text{Eq20})$$

where $c_R(n_{frame}, k_{dwell})$ is the $N_{chp} \times 1$ receive spreading code vector over dwell k_{dwell} and time frame n_{frame} , and where $\text{diag}\{\bullet\}$ is the vector-to-diagonal matrix conversion operation and $(\bullet)^*$ is the complex conjugation operation.

Compute $N_{smp} \times L_{port}$ despread baseband signal matrix $Y_R(n_{frame}, k_{dwell})$, using linear signal separation algorithm

$$Y_R(n_{frame}, k_{dwell}) = X_R(n_{frame}, k_{dwell}) W_R(n_{frame}, k_{dwell}), \quad (\text{Eq21})$$

where $W_R(n_{frame}, k_{dwell})$ is an $N_{chp} \times L_{port}$ linear combining matrix.

Convert the despread baseband signal matrix $Y_R(n_{frame}, k_{dwell})$ back to a sequence of $1 \times L_{port}$ despread baseband signal vectors

$$\{\hat{d}_R(n_{sym}; n_{frame}, k_{dwell})\}_{n_{sym}=0}^{M_{sym}-1}$$

by applying an $N_{smp}:1$ parallel-to-series (P/S) conversion operation to each row of $Y_R(n_{frame}, k_{dwell})$.

In one embodiment, the despreading operations performed in the downlink FS despreaders, shown in FIG. 37, are substantively equivalent to those shown in FIG. 36, except that they are only applied to time slots and frequency channels monitored by the downlink receiver.

If the baseband signal sequence possesses structure that can be exploited in an adaptation algorithm, then the CPDS adaptation procedure shown in FIG. 23 can be used to directly compute the linear combining matrix $W_R(n_{frame}, k_{dwell})$. For the exemplary FS transceiver and network parameters described in Table 2, the baseband cyclic prefix introduces self-coherence that can be exploited using the auto-self-coherence (auto-SCORE) algorithm described in (Error! Reference source not found., Error! Reference source not found., Error! Reference source not found.).

If the spreading code is known except for an unknown frequency offset, then unstructured parameter estimation techniques that are well-known in the art, such as Multiple Signal Classification (MUSIC), can be used to detect and determine the frequency offset of every signal using the known receive spreading code, and equally well-known methods such as linearly-constrained power minimization (LCPM) can be used to develop linear combiner weights that can extract those signals from the received environment.

If the spreading code length N_{chp} is much larger than the number of signals impinging on the receiver, e.g., at the downlink receiver in the exemplary environment, or in extreme long-range communication scenarios where the spreading gain of the modulation format is being used to raise the signal-to-noise ratio (SNR) of the signal above a thermal noise floor, then alternative methods that exploit the duality of the FS and MOS-DSSS spreading methods can be used to jointly detect and estimate signals using the known receive spreading code using an FFT-LS algorithm applied over a subset of the baseband signal samples. In this case, the receive spreading gain is treated as the signal, and the baseband signal samples are treated as the spreading code for purposes of signal detection and frequency offset estimation. Once this step has been accomplished, then the true

linear combiner weights $W_R(n_{frame}, k_{dwell})$ can be constructed using an LCPM algorithm for each of the detected signals.

The extension of alternate FS spreading methods to transceivers employing polarization/spatial diverse multi-element antenna arrays, and to macrodiverse reception methods, is straightforward. The FS method should be especially well suited to strongly-macrodiverse networks, as the LCPM algorithm is not dependent on the time-bandwidth product of the baseband.

In yet a further embodiment, the network selects a particular implementation based on its strategic value, which is strongly influenced by the desired tradeoff between Grade of Service ('GoS') and the required Codec SINR (signal-to-interference-and-noise ratio). If the network is using a fully-blind, least-squares despreaders, then between 10.5 dB and 15 dB required SINR, the performance change shifts; below that noise level the GoS rises as the number of hop channels decrease, so the best strategy is to minimize hops, which means spreading has a strong benefit. However, around 12-13 dB required SINR a 'crossover' effect is experienced, after which the GoS drops as the number of hop channels decrease, so the best strategy then becomes to maximize hops, which means there is no experienced benefit without scheduling. (This may be changed if the signalers are not experiencing the 1 bit/symbol Shannon limit of transmission capacity.) If, however, the network is using a Matched-Filter despreaders ('MF'), the changeover point is significantly different; it occurs nearly at 0 dB required SINR. Under these conditions an 8.6 dB Forward Error Correction ('FEC') coding gain (0.5 dB codec input SINR) is required before any 'ad hoc' MF spreading provides a benefit; while above this, there is no benefit to any MF spreading without FEC (so again, scheduling is required). An FEC can be part of an error detection/correction decoder for a coded communication system in which information bits are "encoded" with redundant parity bits at the transmitter, which are then used to detect and (more typically) correct for errors in the received bits or signal.

In one embodiment, the present description assumes the "code generation" process is the result of the hardware on which the method is effected performing operations outside the scope of the invention, in order to add bits to the input information stream that can be used to detect packet errors, and to correct for such errors if possible in the Symbol demodulator, which is also outside scope of the invention. The invention does not necessarily enhance this process beyond the means for doing so which are obvious extensions of the approach to those experienced and skilled in the field(s) of this invention, but can allow such enhancements to be added or incorporated.

In another embodiment, one possible feature of the present description is that it provides a useable base on which further enhancements can be more effectively deployed. One such specific further enhancement is the use of macrodiverse solutions, particularly for the CPDS; and a further sub-enhancement of that therein is a weakly macrodiverse solution where the SM can be demodulated at any DAP to provide later signal improvement.

Additionally, in one embodiment, another possible feature of the present description is that its use of a blind despreading algorithm renders the network's communications interference-excising, creates far greater tolerance, and operates in conditions of greater variability of transmit power ranges. Additionally, because the transmissions are 'open loop' (no

requirement for a return ‘ack’ or handshake) both power management and signal feedback overheads are greatly simplified or reduced.

Still yet, in another embodiment, one possible feature of the present description is that its flexible incorporation of CPDS cyclic prefixes at the symbol and chip level, and its instantiation over discrete time-frequency dwells, either with fixed time framing, or with ad hoc time slotting, allow it to be deployed over a wide range of frequency bands, and over a wider range of network topologies, transmission ranges, and use scenarios. While the parameters given in Table 1 for one embodiment have been chosen to provide full compliance with FCC §15.247 requirements for intentional radiators in that band, and for point-to-multipoint cellular network topologies, long-range transmissions, and Smart Grid use scenarios, it should be recognized that the embodiments in the present description can be applied to:

- other frequency bands, including ISM bands currently used for 802.11 wireless local area networks (WLAN’s), 802.15 wireless personal area networks (WPAN’s), or cellular telephony networks, or very low frequency bands used for near-field communications (NFC);

- White Spaces deployments where frequency channels are dynamically and potentially noncontiguously allocated based on spectrum availability in different geographical areas;

- other network topologies, including ad hoc point-to-point topologies, and mesh network topologies;

- other transmission ranges, including extremely short ranges consistent with WPAN’s and NFC links;

- other M2M use scenarios, including RFID, short-range medical networks, embedded automotive networks, point-of-sale financial transaction networks, and so on; and

- heterogeneous cognitive networks where the modulation format is software defined and reformatted on a dynamic basis for different topologies and use scenarios;

In one embodiment, the alternate frame synchronous embodiment further enhances flexibility of the embodiments in the present description, by allowing the invention to be applied over extreme long ranges, e.g., consistent with airborne and satellite communication networks, and by allowing the invention to be used with, or overlaid on top of, transceivers employing arbitrary baseband modulation formats, e.g., LTE communication networks.

In another embodiment of this invention, a further possible feature of the embodiments in the present description is that networks may be formed comprising devices capable of playing different roles, so any device may be serving as at least one Signaling Machine (‘SM’) and any other device may be serving (at the same time) as one Data Aggregation Point (‘DAP’). This is possible with each device comprising at least one antenna and one transceiver for exchanging wireless transmissions. In this embodiment the method will be comprising: incorporating into each transmission at each transceiver a Cyclic-prefix Direct-Sequence (‘CPDS’) differentiator for that transmission with time-channelized despreading; fitting each transmission into a series of frames of Upload Transmissions (‘UpLink’) and Download Transmissions (‘DownLink’); transmitting from any device on any UpLink; and, transmitting from any device on any DownLink.

Any specific subset of the method may be effected through any combination of hardware and software elements. Hardware elements already well-known and standard

to the state of the art include a wide range of Central Processing Units (CPUs), Linear Processing Units (LPUs), Vector Processing Units (VPUs), and Signal Processing Units (SPUs), which in turn may comprise single, dual, quad, or higher combinations of lesser such elements. Hardware elements also include both programmable and re-programmable floating-point gate arrays (FPGAs), application-specific integrated circuits (ASICs), programmable read-only memory (PROM) units, erasable-and-programmable read-only memory (EPROM) units, and electronically erasable-and-programmable read-only memory (EEPROM) units. The conversion between digital and analog, and analog and digital, representations may be through DAC/ADC chips, circuitry, or other transformational means incorporating both hardware (transceivers, processors) and software elements. Accordingly all elements disclosed in the present description must be understood as being capable of being effected in a hardware-only, physically transforming device. However, as no human has either a radio (or other electromagnetic) transceiver capabilities, or the capabilities of any of the speed, precision and capacity of perception, comprehension, memorization, and continuing real-time transformation of such signals as required to effect embodiments in the present description, even though some elements may be incorporated in software, and the method as a whole can be abstractly comprehended by an individual human being, the method cannot be effected by any human being without direct, physical, and continuing assistance by an external device. Therefore the present description incorporates all existing and yet-to-be-devised hardware elements which instantiate and process the digital signals using the method herein, known to the present state of the art or effected as functional equivalents to the methods and techniques disclosed herein.

Some of the above-described functions may be composed of instructions, or depend upon and use data, that are stored on storage media (e.g., computer-readable medium). The instructions and/or data may be retrieved and executed by the processor. Some examples of storage media are memory devices, tapes, disks, and the like. The instructions are operational when executed by the processor to direct the processor to operate in accord with the embodiments in the present description; and the data is used when it forms part of any instruction or result therefrom.

The terms “computer-readable storage medium” and “computer-readable storage media” as used herein refer to any medium or media that participate in providing instructions to a CPU for execution. Such media can take many forms, including, but not limited to, non-volatile (also known as ‘static’ or ‘long-term’) media, volatile media and transmission media. Non-volatile media include, for example, one or more optical or magnetic disks, such as a fixed disk, or a hard drive. Volatile media include dynamic memory, such as system RAM or transmission or bus ‘buffers’. Common forms of computer-readable media include, for example, a floppy disk, a flexible disk, a hard disk, magnetic tape, any other magnetic medium, a CD-ROM disk, digital video disk (DVD), any other optical medium, any other physical medium with patterns of marks or holes.

Memory, as used herein when referencing to computers, is the functional hardware that for the period of use retains a specific structure which can be and is used by the computer to represent the coding, whether data or instruction, which the computer uses to perform its function. Memory thus can be volatile or static, and be any of a RAM, a PROM, an EPROM, an EEPROM, a FLASHEPROM, any other

memory chip or cartridge, a carrier wave, or any other medium from which a computer can read data, instructions, or both.

I/O, or 'input/output', is any means whereby the computer can exchange information with the world external to the computer. This can include a wired, wireless, acoustic, infrared, or other communications link (including specifically voice or data telephony); a keyboard, tablet, camera, video input, audio input, pen, or other sensor; and a display (2D or 3D, plasma, LED, CRT, tactile, or audio). That which allows another device, or a human, to interact with and exchange data with, or control and command, a computer, is an I/O device, without which any computer (or human) is essentially in a solipsitic state.

The above description of the invention is illustrative and not restrictive. Many variations of the disclosed embodiments may become apparent to those of skill in the art upon review of this disclosure. The scope of the embodiments of the present description should, therefore, be determined not with reference to the above description, but instead should be determined with reference to the appended claims along with their full scope of equivalents.

While the present description has been described chiefly in connection with one embodiment, these descriptions are not intended to limit the scope of any of the embodiments to the particular forms (whether elements of any device or architecture, or steps of any method) set forth herein. It will be further understood that the elements or methods of the disclosed embodiments are not necessarily limited to the discrete elements or steps, or the precise connectivity of the elements or order of the steps described, particularly where elements or steps which are part of the prior art are not referenced (and are not claimed). To the contrary, the present descriptions are intended to cover such alternatives, modifications, and equivalents as may be included within the spirit and scope of the embodiments in the present description as defined by the appended claims and otherwise appreciated by one of ordinary skill in the art.

I claim:

1. A method for physically secure digital signal processing for intercommunication between members, of a wireless Machine-to-Machine ('M2M') network comprising at least one Signaling Machine ('SM') and one Data Aggregation Point (DAP), with each SM and DAP individually comprising at least one transceiver, at least one antenna, and digital signal processing means, by exchanging wireless transmissions between a first member and a second member, said method comprising:

first, for each intended intercommunication between any first member and second member,

selecting for each transmission of that intercommunication a Cyclic-Prefix Direct-Sequence ('CPDS') differentiator by any of randomly, pseudorandomly, or a varying selection method; then,

modifying the intended intercommunication by said CPDS differentiator;

transmitting the intended intercommunication that has been modified to an intended second member;

receiving at the antenna of the second member the intended communication and:

identifying, through use of a blind, time-channelized despreading algorithm, the intended intercommunication from other non-intended signals;

identifying the selected CPDS differentiator modifying the intended intercommunication;

and, restoring the received intended intercommunication by removing the selected CPDS differentiator.

2. The method for physically secure digital signal processing for intercommunication between members of the wireless M2M network as in claim 1, wherein the selected CPDS differentiator further comprises a combination of a transformation of the intended communication by a receive mask, a source mask, and a cyclic prefix for any of a set of symbols comprising the intercommunication to be transmitted.

3. A method for wireless intercommunication between at least one Signaling Machine ('SM') and one Data Aggregation Point (DAP) each belonging to a set of like devices, all transmitting and receiving and belonging to the same network, of which each said device is a node, said method further comprising:

effecting within a selected frequency range a frequency-hop direct-sequence (FHDS), spread-spectrum modulation format further comprising time slots, frequency channels, at least one data burst and guard intervals; providing through said FHDS modulation format, cyclic chip-level and symbol-level cyclic prefixes to control channel multipath and interference loading; and, employing transmission information that is randomly determined at any node in the network, not provisioned by the network nor known to receivers in the network; incorporating a spreading code for every uplink and downlink;

including in said randomly determined transmission information on each uplink, and randomly varying over every time frame:

the time slots and frequency channels used for that specific uplink and by that specific node;

the spreading code used for that specific uplink and by that specific node; and,

elements of a source symbol mask applied to the data bursts prior to spreading;

including in said randomly determined transmission information on each downlink:

the spreading code used for that specific downlink and by that specific node and randomly varied in every time slot of each time frame; and,

elements of a source symbol mask applied to the data bursts prior to spreading also randomly varied over every time frame;

transmitting from each downlink transmit node, over a downlink frequency channel using an algorithm that is any of the set of providable, known to, and learnable by each downlink receiver allowed to communicate with that downlink transmit node, said algorithm being further locally and independently set at said downlink transmit node.

4. The method for wireless intercommunication as in claim 3, wherein the step of transmitting from each downlink transmit node, over the downlink frequency channel, varies the frequency channel pseudorandomly over each time slot of each time frame.

5. The method for wireless intercommunication between at least one Signaling Machine ('SM') and one Data Aggregation Point ('DAP') each belonging to a set of like devices as in claim 3, wherein the step of employing transmission information that is randomly determined at any node in the network, not provisioned by the network nor known to the receivers in the network, is provisioned at and by each transmitter with each intended receiver being blind to the choice of that randomly determined transmission information, and utilizing only rudimentary provisioning from any specific transmitter in the network to only its intended set of receivers in the network of a commonly-known and shared

receive symbol mask for all signals intended for a given set of receivers so as to differentiate them from transmissions by that specific transmitter intended for other nodes in the network, as well as transmissions from other transmitters in the network intended for that particular set of receivers.

6. A method for physically secure digital signal processing for wireless Machine-to-Machine ('M2M') networks, said networks comprising at least one set of transceivers comprising at least one Signaling Machine ('SM') and one Data Aggregation Point ('DAP') with each SM and DAP comprising at least one antenna and one transceiver for exchanging wireless transmissions, said method comprising:

transforming each transmission by incorporating into each transmission at each transceiver a Cyclic-Prefix Direct-Sequence ('CPDS') differentiator for that transmission with time-channelized despreading;

fitting each transmission into a series of frames of Upload Transmissions ('UpLink') and Download Transmissions ('DownLink');

transmitting from the SM on any UpLink;

transmitting from the DAP on any DownLink; and,

after receiving each transmission at an antenna, for each such transmission:

downconverting the transmission;

demultiplexing the downconverted transmission into physical dwells which are separated into time slots and frequency channels and accessible to the receiver, thus forming for each time slot, frequency channel, and frame a received signal; and,

adaptively despreading the received signal to create an incoming and received digital symbol stream.

7. The method for physically secure digital signal processing for wireless M2M networks as in claim 6, where in the step of then fitting each transmission into the series of frames of Upload Transmissions ('UpLink') and Download Transmissions ('DownLink') further comprises:

for information intended for transmission in a single UpLink slot of each frame and thus passing through an UpLink transmitter:

first passing said information through baseband encoding utilizing any of a set of baseband encoding algorithms and adding Physical Layer (PHY) signatures including any of training preambles and Unique Words, to create a baseband source symbol stream output from any encoder, at each symbol index used by the UpLink transmitter;

passing the baseband source symbol stream to a cyclic-prefix direct-sequence ('CPDS') spreader;

segmenting the baseband source symbol stream into symbol-source data segments;

modulating each symbol-source data segment to generate the spread source data stream output from the CPDS spreader at each chip index;

then subsequently pulse-amplitude modulating the spread source data stream output;

converting this subsequently pulse-amplitude modulated spread source data stream output to an analog signal-in-space ('SiS');

upconverting this analog SiS to a desired source frequency selected by the uplink transmitter within each time-frame n_{frame} ;

for information intended for transmission in a single DownLink slot of each frame, and thus passing through a DownLink transmitter:

first passing said information through baseband encoding to create a baseband source symbol stream;

then passing the baseband source symbol stream to a cyclic-prefix direct-sequence ('CPDS') spreader which modulates each data segment to generate the spread source data stream output from the CPDS spreader at each chip index;

then subsequently pulse-amplitude modulating the spread source data stream output;

converting this subsequently pulse-amplitude modulated spread source data stream output to an analog signal-in-space ('SiS'); and,

upconverting this analog SiS to a desired source frequency selected by the downlink transmitter over each time slot and transmitting this analog SiS over the desired source frequency over each time slot at a source power level that is held constant over every time slot.

8. The method for physically secure digital signal processing for wireless M2M networks as in claim 7, wherein the step of selecting a desired source frequency by the uplink transmitter within time-frame n_{frame} further comprises utilizing any of a set of fixed, provisioned, pseudo-randomly directed, and randomly-directed selection methods within each frame.

9. The method for physically secure digital signal processing for wireless M2M networks as in claim 7 wherein the step of upconverting this analog SiS to a desired source frequency selected by the uplink transmitter over time slot n_{slot} ; and transmitting this analog SiS over the desired source frequency over time slot n_{slot} further comprises:

selecting randomly a source transmit time $t_S(n_{frame})$ and transmit frequency $f_S(n_{frame})$ within each frame, by randomly selecting dwell index $k_{dwell}(n_{frame})$ for that frame, without any prior scheduling or coordination between the uplink transmitter and the uplink receivers in the network;

mapping $k_{dwell}(n_{frame})$ to time slot $k_{slot}(n_{frame})$ and frequency channel $k_{chan}(n_{frame})$; and,

selecting $t_S(n_{frame})$ from $k_{slot}(n_{frame})$ and $f_S(n_{frame})$ from $k_{chan}(n_{frame})$ via a look-up table.

10. The method for physically secure digital signal processing for wireless M2M networks as in claim 7, wherein the step of selecting a desired source frequency $f_S(n_{slot})$ by the downlink transmitter over time slot n_{slot} further comprises selecting a frequency channel $k_{chan}(n_{slot})$ and using the selected frequency channel to set a source frequency $f_S(n_{slot})$ using a pseudorandom selection algorithm based on the slot index n_{slot} and the source index l_S .

11. The method for physically secure digital signal processing for wireless M2M networks as in claim 6, further comprising, for any DownLink transmission, selecting a transmit frequency known to each intended DownLink receiver in the network over at least a subset of slots within each frame, without coordinating the selection with any other set of downlink transmitters in the network.

12. The method for physically secure digital signal processing for wireless M2M networks as in claim 6, further comprising, for any DownLink transmission, detecting the transmit frequency over any of each slot and a subset of monitored slots and frequency channels, without coordination with the DownLink transmitter.

13. The method for physically secure digital signal processing for wireless M2M networks as in claim 6, wherein the cyclic-prefix direct-sequence ('CPDS') spreader produces a CPDS uplink spreading structure using the following steps:

57

passing the baseband source symbols intended for transmission over time-frame n_{frame} through a $1:M_{sym}$ serial-to-parallel (S/P) convertor to form a $M_{sym} \times 1$ source symbol vector

$$b_S(n_{frame}) = [b_S(n_{frame}M_{sym} + n_{sym})]_{n_{sym}=0}^{M_{sym}-1};$$

then performing an element-wise multiplication of this source symbol vector and an $M_{sym} \times 1$ symbol mask vector

$$m_{RS}(n_{frame}) = [m_{RS}(n_{sym}; n_{frame})]_{n_{sym}=0}^{M_{sym}-1},$$

where $m_{RS}(n_{sym}; n_{frame})$ is the product of a receive symbol mask $m_R(n_{sym}; n_{frame})$ that is known to the intended receiver; and a source symbol mask $m_S(n_{sym}; n_{frame})$ that is unique to each source, and belongs to any of: a set of masks known to the receiver, a code with any of an unknown index and offset, and a set of masks unknown to the receiver but estimable as part of the receive adaptation procedure;

generating a code vector utilizing a code chosen by any of the set of random or pseudorandom selections over every dwell and not known at the intended receiver; utilizing the generated code vector in spreading the full baseband data vector $d_S(n_{frame})$;

passing that spread baseband data vector stream through a $N_{chp} \times N_{sym}$ Matrix/Serial converter; and producing an output symbol stream $s_S(n_{chp})$.

14. The method for physically secure digital signal processing for wireless M2M networks as in claim 13, wherein the source and receive masks each possess a constant modulus.

15. The method for physically secure digital signal processing for wireless M2M networks as in claim 13, wherein the source and receive masks are both designed to be circularly symmetric and cross-scrambling.

16. The method for physically secure digital signal processing for wireless M2M networks as in claim 13, wherein: the source symbol mask is a complex sinusoid with a cyclic source frequency offset $f_S(n_{frame})$ chosen randomly and communicated to the receiver, said source symbol mask given by $m_S(n_{sym}; n_{frame}) = \exp\{j2\pi f_S(n_{frame})n_{sym}\}$.

17. The method for physically secure digital signal processing for wireless M2M networks as in claim 13, wherein at least one receive symbol mask has been made unique to each DAP in the network, and each DAP uses the receive symbol mask to identify those SM's intending to communicate with it.

18. The method for physically secure digital signal processing for wireless M2M networks as in claim 11, wherein the receive symbol mask has been made common to every DAP in the network, allowing any DAP to despread any SM in that DAP's field of view.

19. The method for physically secure digital signal processing for wireless M2M networks as in claim 18, wherein the network is macrodiverse and the symbol streams which are any of the set received and despread at multiple DAP's, are further processed at deeper aggregation sites in the network.

20. The method for physically secure digital signal processing for wireless M2M networks as in claim 13, further comprising applying a modulation-on-symbol direct-se-

58

quence spread spectrum ('MOS-DSSS') operation, in which the spreading code is repeated over every baseband symbol within each hop and is used to spread the symbol vector $d_S(n_{frame})$ using a spreading code $c_S(n_{frame})$.

21. The method for physically secure digital signal processing for wireless M2M networks as in claim 13 wherein: the step of performing an element-wise multiplication of this source symbol vector and an $M_{sym} \times 1$ symbol mask vector is applied in the time domain if the cyclic symbol prefix duration=0; and, a cyclic chip prefix is added to the spreading code.

22. The method for physically secure digital signal processing for wireless M2M networks as in claim 13, wherein the step of performing an element-wise multiplication of the source symbol vector and an $M_{sym} \times 1$ symbol mask vector

$$m_{RS}(n_{frame}) = [m_{RS}(n_{sym}; n_{frame})]_{n_{sym}=0}^{M_{sym}-1},$$

where $m_{RS}(n_{sym}; n_{frame})$ is the product of a receive symbol mask $m_R(n_{sym}; n_{frame})$ that is known to the intended receiver and a source symbol mask $m_S(n_{sym}; n_{frame})$ of a set of masks unknown to the receiver but estimable as part of the receive adaptation procedure, determines said estimable set of masks using features of the source symbols such as any of adherence to known symbol constellations, unique words, training sequences, and known properties of the source symbol mask.

23. The method for physically secure digital signal processing for wireless M2M networks as in claim 13, wherein: the source symbol mask is the complex sinusoid with the cyclic source frequency offset $f_S(n_{frame})$ chosen pseudorandomly over frame n_{frame} and communicated to the receiver, said source symbol mask given by $m_S(n_{sym}; n_{frame}) = \exp\{j2\pi f_S(n_{frame})n_{sym}\}$.

24. The method for physically secure digital signal processing for wireless M2M networks as in claim 13, wherein: the source symbol mask is a complex sinusoid with a chosen cyclic source frequency offset $f_S(n_{frame})$ communicated to the receiver, said source symbol mask given by $m_S(n_{sym}; n_{frame}) = \exp\{j2\pi f_S(n_{frame})n_{sym}\}$; and, the receive symbol mask is tied to the specific time slot and hop channel used by the SM over each time frame.

25. The method for physically secure digital signal processing for wireless M2M networks as in claim 13; wherein: the step of performing an element-wise multiplication of this source symbol vector and an $M_{sym} \times 1$ symbol mask vector, is applied in the frequency domain using a discrete Fourier transform ('DFT') if the cyclic symbol prefix duration >0; and, that resultant masked symbol vector is then converted back to the time domain utilizing an inverse DFT.

26. The method for physically secure digital signal processing for wireless M2M networks as in claim 6, wherein the step of adaptively despreading the received signal to create an incoming and received digital symbol stream further comprises:

passing the received signal, for each physical dwell the demultiplexed and downconverted transmission, through an UpLink CPDS despreader; adaptively despreading the received signal by applying to it an adaptation algorithm using the received signal's weighting WR observed by the receiver; and, passing the adaptively despread digital stream to a symbol demodulator which also uses the adaptation algorithm using for any combination of environmental delay and

degradation effects, frequency offset estimates from the observed weighting by the receiver, to create a resulting symbol stream.

27. The method for physically secure digital signal processing for wireless M2M networks as in claim 6, wherein the step of transforming each transmission further comprises:

utilizing input from a real-world, random-number, sourcing-sensor element that provides a truly random kernel from real-world chance events to randomly generate a spreading code over every transmit opportunity which is every frame on the uplink, and every time slot on the downlink;

and then providing that spreading code to a CPDS spreader that generates the CPDS differentiator.

28. The method for physically secure digital signal processing for wireless M2M networks as in claim 6, wherein the step of transforming each transmission further comprises:

utilizing input from a real-world, random-number, sourcing-sensor element that provides a truly random kernel from real-world chance events to randomly generate a physical dwell index which is time slot and frequency channel over every time frame;

and then providing that physical dwell index to a CPDS spreader that generates the CPDS differentiator for the uplink transmission.

29. The method for physically secure digital signal processing for wireless M2M networks as in claim 6, wherein the step of transforming each transmission further comprises:

utilizing input from a real-world, random-number, sourcing-sensor element that provides a truly random kernel from real-world chance events to randomly generate at least one element of the source symbol mask over every time frame; and then providing said randomly generated at least one element to a CPDS spreader that generates the CPDS differentiator for the uplink transmission.

30. The method for physically secure digital signal processing for wireless M2M networks as in claim 6, wherein the step of transforming each transmission further comprises:

utilizing input from a real-world, random-number, sourcing-sensor element that provides a truly random kernel from real-world chance events to randomly select an intended uplink receiver from a set of candidate uplink receivers over every time frame;

and then providing that selection of uplink receiver to a CPDS spreader that generates the CPDS differentiator for the uplink transmission.

31. The method for physically secure digital signal processing for wireless M2M networks as in claim 6, wherein the step of transforming each transmission further comprises:

using utilizing input from a real-world, random-number, sourcing-sensor element that provides a truly random kernel from real-world chance events to select any combination of the set of spreading code, physical dwell index, source signal mask, cyclic frequency offset, and intended receiver; and then providing that selected combination to a CPDS spreader that generates the CPDS differentiator for that transmission.

32. The method for physically secure digital signal processing for wireless M2M networks as in claim 6, whereby whenever a node is duplicated an original source and intended recipient can, each independently or together,

compare any of the Physical Layer ('PHY') data bits in the received transmissions and use any discrepancy from previously observed values to identify an adversarial node;

and then ignore that now-identified adversarial node, alert other nodes in the network to both the presence, and the PHY observable characteristics, of that now-identified adversarial node, and otherwise respond.

33. The method for physically secure digital signal processing for wireless M2M networks as in claim 6, wherein the cyclic-prefix direct-sequence ('CLAUS') spreader produces a CPDS uplink spreading structure using the following steps:

passing the baseband source symbols intended for transmission over time-frame n_{frame} through a $1:M_{sym}$ serial-to-parallel (SIP) convertor to form a $M_{sym} \times 1$ source symbol vector

$$b_S(n_{frame}) = [b_S(n_{frame} M_{sym} + n_{sym})]_{n_{sym}=0}^{M_{sym}-1};$$

then performing an element-wise multiplication of this source symbol vector and an $M_{sym} \times 1$ symbol mask vector

$$m_{RS}(n_{frame}) = [m_{RS}(n_{sym}; n_{frame})]_{n_{sym}=0}^{M_{sym}-1},$$

where $m_{RS}(n_{sym}; n_{frame})$ is the product of a receive symbol mask $m_R(n_{sym}; n_{frame})$ that is known to the intended receiver; and a source symbol mask $m_S(n_{sym}; n_{frame})$ that is unique to each source, and belongs to any of: a set of masks known to the receiver, is a code with any of an unknown index and offset, and a set of masks unknown to the receiver but estimable as part of the receive adaptation procedure;

applying a symbol-level cyclic-prefix;

generating a code vector using a code chosen by any of the set of randomly or pseudorandomly selections over every dwell and not known at the intended receiver; using the result in spreading the full baseband data vector $d_S(n_{frame})$;

passing that spread, cyclic chip prefixed, baseband data vector stream through a $N_{chp} \times N_{sym}$ Matrix/Serial converter; and,

producing an output symbol stream $s_S(n_{chp})$.

34. A device for adaptively despreading a received signal to create an incoming and received digital symbol stream comprising:

at least one antenna which receives an incoming analog signal-in-space, and passes it to;

a downconverter connected to at least one lowpass filter ('LPF') and then at least one analog-to-digital converter ('ADC');

a clock connected and signaling for a time slot to a channel identifying element which provides a frame for receipt for the time slot to a Local Oscillator ('LO') that also is connected to and receives a timing signal from the clock, with the LO also connected to and passing that combination to the downconverter;

said at least one ADC connected to and passing the received signal to;

a Cyclic-Prefix Direct-Sequence ('CPDS') despreader which is further connected to and passing a despread series to a symbol demodulator, said despread series being modified with a feedback loop through an adap-

61

tation algorithm element which uses the received signal's weighting observed by the receiver, said adaptation algorithm element being connected to both the CPDS despreader and the symbol demodulator;
said symbol demodulator then incorporating frequency 5
offset estimates also provided by the adaptation algorithm for environmental delay/degradation effects actually observed by the receiving device, to produce a series of symbols.

* * * * *

10

62

UNITED STATES PATENT AND TRADEMARK OFFICE
CERTIFICATE OF CORRECTION

PATENT NO. : 9,648,444 B2
APPLICATION NO. : 13/999040
DATED : May 9, 2017
INVENTOR(S) : Agee

Page 1 of 1

It is certified that error appears in the above-identified patent and that said Letters Patent is hereby corrected as shown below:

On the Title Page

The following Related Applications data please add item (62):

RELATED APPLICATIONS

This application claims benefit of Serial No. 61/848,463, filed 01/05/2013; and Serial No. 61/849,745, filed 02/01/2013

Signed and Sealed this
Eleventh Day of September, 2018

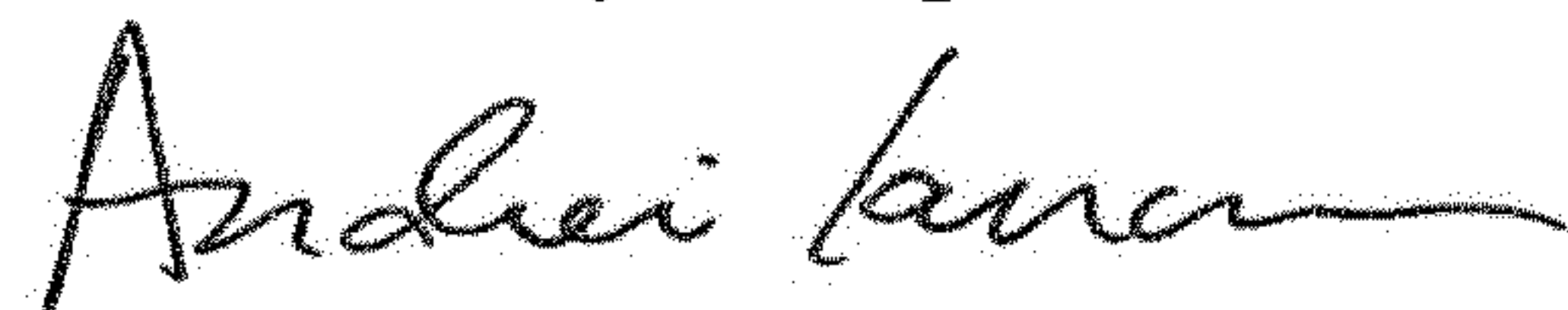

Andrei Iancu
Director of the United States Patent and Trademark Office