

US009600571B2

(12) **United States Patent**
Shaashua et al.

(10) **Patent No.:** **US 9,600,571 B2**
(45) **Date of Patent:** **Mar. 21, 2017**

(54) **INTEROPERABILITY MECHANISMS FOR INTERNET OF THINGS INTEGRATION PLATFORM**

(56) **References Cited**

U.S. PATENT DOCUMENTS

(71) Applicant: **Neura, Inc.**, Sunnyvale, CA (US)
(72) Inventors: **Triinu Magi Shaashua**, Sunnyvale, CA (US); **Ori Shaashua**, Sunnyvale, CA (US)
(73) Assignee: **NEURA, INC.**, Sunnyvale, CA (US)

6,601,026 B2 * 7/2003 Appelt G06F 17/30616 704/9
7,216,179 B2 5/2007 Ott et al.
7,921,686 B2 * 4/2011 Bagepalli et al. 70/223
8,271,878 B2 9/2012 Kane et al.
8,280,009 B2 * 10/2012 Stepanian G06F 21/10 348/14.04
8,489,596 B1 7/2013 Milton et al.
8,881,257 B2 * 11/2014 Cha et al. 726/10

(Continued)

(*) Notice: Subject to any disclaimer, the term of this patent is extended or adjusted under 35 U.S.C. 154(b) by 0 days.

FOREIGN PATENT DOCUMENTS

(21) Appl. No.: **13/957,255**

CN 102215150 A 10/2011
CN 202856780 U 4/2013

(Continued)

(22) Filed: **Aug. 1, 2013**

OTHER PUBLICATIONS

(65) **Prior Publication Data**
US 2015/0019710 A1 Jan. 15, 2015

Weber, "Internet of things—Need for a new legal environment?", 2009.*

(Continued)

Related U.S. Application Data

Primary Examiner — O. C. Vostal
(74) *Attorney, Agent, or Firm* — Perkins Coie LLP

(60) Provisional application No. 61/845,369, filed on Jul. 11, 2013.

(57) **ABSTRACT**

(51) **Int. Cl.**
G06F 17/30 (2006.01)
H04L 12/26 (2006.01)

A method of maintaining interoperability amongst Internet of Things (IoT) devices connected via an IoT integration platform is disclosed. The method includes: receiving a selection of a semantic label associated with an IoT device; determining a recommendation of an interoperable rule based on the semantic label; presenting the recommendation of the interoperable rule on the rule management interface; receiving a confirmation from the user to activate the interoperable rule; monitoring to detect the condition trigger of the interoperable rule in a network of connected IoT devices; and when the condition trigger is detected, executing the action policy of the interoperable rule to control one or more of the connected IoT devices.

(52) **U.S. Cl.**
CPC **G06F 17/30705** (2013.01); **H04L 43/10** (2013.01)

(58) **Field of Classification Search**
CPC G06F 17/30705; H04L 43/10
USPC 709/224
See application file for complete search history.

21 Claims, 18 Drawing Sheets

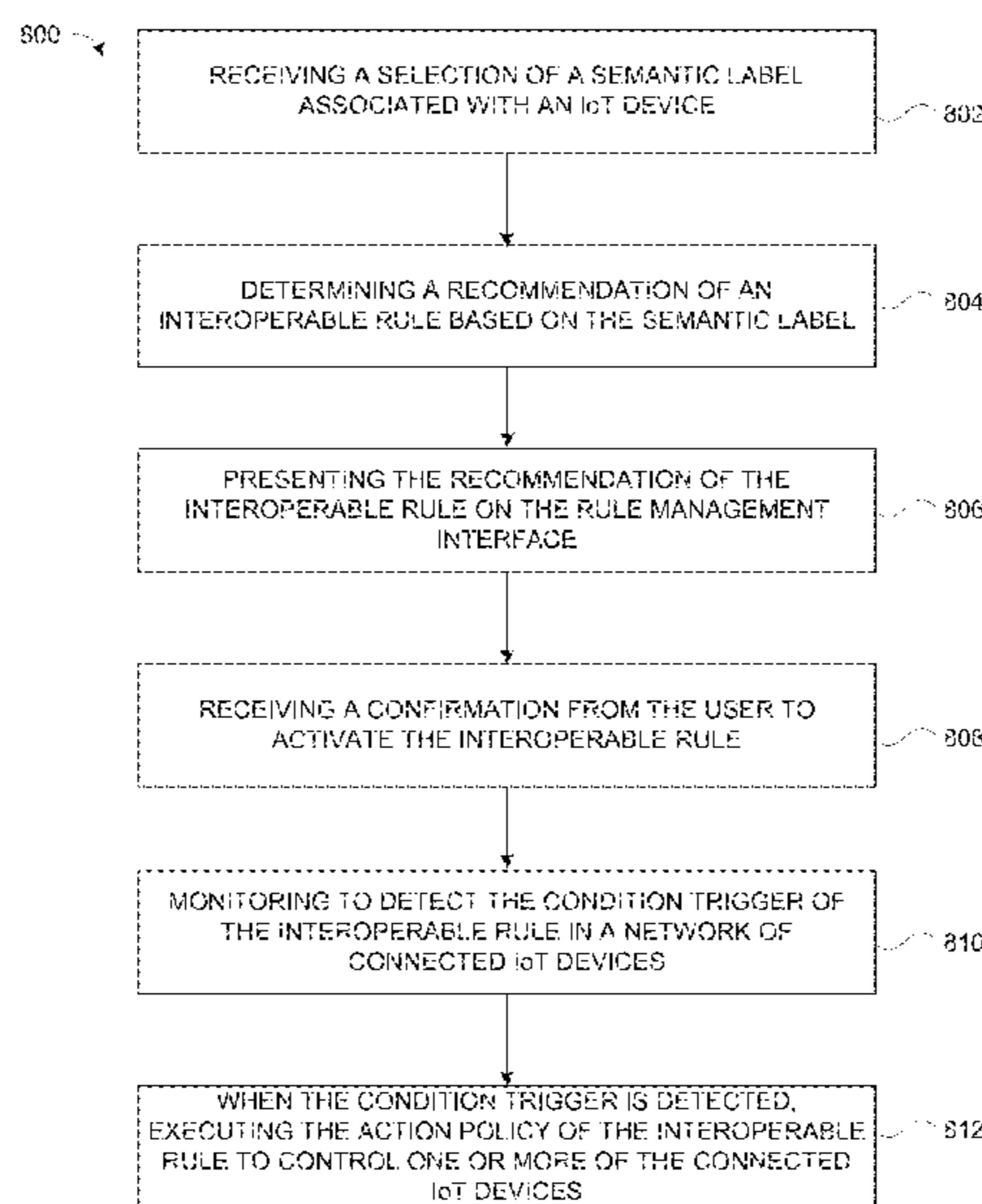

(56)

References Cited

U.S. PATENT DOCUMENTS

8,965,845 B2 * 2/2015 Calo G06F 17/30575
370/254
9,372,922 B2 6/2016 Shaashua et al.
2005/0193222 A1 * 9/2005 Greene H04L 63/102
726/5
2007/0112574 A1 * 5/2007 Greene 705/1
2009/0006469 A1 1/2009 Jain et al.
2009/0063665 A1 * 3/2009 Bagepalli H04L 63/166
709/222
2009/0089078 A1 * 4/2009 Bursey G06Q 10/101
705/300
2009/0171906 A1 * 7/2009 Adams et al. 707/3
2011/0218037 A1 9/2011 Singh et al.
2012/0079092 A1 3/2012 Woxblom et al.
2012/0150642 A1 * 6/2012 Kandanalala G06Q 30/02
705/14.53
2012/0244885 A1 9/2012 Hefetz et al.
2012/0284777 A1 * 11/2012 Eugenio H04L 67/20
726/4
2012/0296909 A1 * 11/2012 Cao G06F 17/30867
707/737
2012/0303618 A1 11/2012 Dutta et al.
2013/0258953 A1 * 10/2013 Huang et al. 370/329
2014/0047322 A1 * 2/2014 Kim et al. 715/234
2014/0181947 A1 * 6/2014 Lund H04L 63/08
726/9
2014/0241354 A1 8/2014 Shuman et al.
2014/0244834 A1 * 8/2014 Guedalia H04L 67/16
709/224
2014/0310243 A1 * 10/2014 McGee et al. 707/639
2014/0330959 A1 * 11/2014 Zhang H04L 12/2803
709/224
2014/0380264 A1 * 12/2014 Misra G06F 8/00
717/100
2015/0006695 A1 * 1/2015 Gupta H04L 41/32
709/223
2015/0019342 A1 1/2015 Gupta
2015/0019553 A1 1/2015 Shaashua et al.
2015/0019714 A1 1/2015 Shaashua et al.
2015/0039635 A1 * 2/2015 Monjas Llorente .. H04L 65/605
707/754

FOREIGN PATENT DOCUMENTS

CN 202870941 U 4/2013
SE WO 2013046021 A2 * 4/2013 H04L 41/046
WO 2013046021 A2 4/2013

OTHER PUBLICATIONS

Gubbi et al., "Internet of Things (IoT): A vision, architectural elements, and future directions", Jan. 2013.*
Kranenburg et al., "The Internet of Things", Oct. 2011.*
Tapiador et al., "Social Stream, a social network framework", 2012.*
Hornsby et al., "From Instant Messaging to Cloud Computing, an XMPP review", 2010.*
Breslin et al., "The Future of Social Networks on the Internet", 2007.*
Harbor Research, "How the Internet of Things, Social Networks & Creative Collaboration Will Shape Future Market Structure", 2009.*
Musial et al., "Social Networks on the Internet", Jan. 2012.*

Heflin et al., "Semantic Interoperability on the Web", 2000.*
Serbanati et al., "Building Blocks of the Internet of Things: State of the Art and Beyond", 2011.*
Bauer et al., "IoT Architecture Reference Model (IoT Arm)", "Chapter 7 IoT Reference Model", 2013.*
Andreev et al., "Internet of Things, Smart Spaces, and Next Generation Networking", 2012.*
Gena et al., "The evaluation of a social adaptive website for cultural events", 2011.*
Barnaghi, "SENSEI: An Architecture for the Real World Internet", First International Workshop on Semantic Interoperability for Smart Spaces (SSIS 2010), this document available on public internet at www.ieee-iscc.org/2010/web_pages/siss/presentation/keynote.pdf, Jun. 30, 2009.*
Zhou, "The Internet of Things in the Cloud: A Middleware Perspective", table of contents, 2012.*
Carrez et al., "Internet of Things—Architecture", 2013.*
Molina, "Semantic middleware development for the Internet of Things", 2012.*
Merriam-Webster, "recommendation", 2015.*
Celesti et al., "How the Dataweb Can Support Cloud Federation: Service Representation and Secure Data Exchange", 2012.*
Shah et al., "The Internet of Things: Technologies, Communications and Computing", 2014.*
Barnaghi et al., "From Data to Actionable Knowledge: Big Data Challenges in the Web of Things", 2013.*
Darianian et al., "Smart Home Mobile RFIC-based Internet-Of-Things Systems and Services", 2008.*
Gronbaek, "Architecture for the Internet of Things (IoT): API and interconnect", 2008.*
Huang et al., "A Semantic Analysis for Internet of Things", 2010.*
Lloret et al., "Ubiquitous Monitoring of Electrical Household Appliances", 2012.*
Miorandi et al., "Internet of Things: Vision, applications and research challenges", 2012.*
Sheth, "Computing for Human Experience", "Semantics-Empowered Sensors, Services, and Social Computing on the Ubiquitous Web", 2010.*
International Search Report and Written Opinion mailed Dec. 25, 2014, for International Application No. PCT/US2014/043923, International Filing Date Jun. 24, 2014, 5 pp.
International Search Report and Written Opinion mailed Dec. 11, 2014, for International Application No. PCT/US2014/044857, International Filing Date Jun. 30, 2014, 6 pp.
International Search Report mailed Jan. 29, 2015, for International Application No. PCT/2014/043915, International Filing Date Jun. 24, 2014, 2 pp.
U.S. Appl. No. 13/957,259 by Shaashua, T.M. et al. filed Aug. 1, 2013.
U.S. Appl. No. 14/315,031 of Shaashua et al. filed Jun. 25, 2014.
Non-Final Office Action Mailed Jul. 30, 2015 of U.S. Appl. No. 13/957,259 by Shaashua, T.M. et al. filed Aug. 1, 2013.
Notice of Allowance mailed Jan. 13, 2016, for U.S. Appl. No. 13/957,259 of Shaashua et al. filed Aug. 1, 2013.
Non-Final Office Action Mailed Jul. 28, 2016 of U.S. Appl. No. 14/315,031 by Shaashua, et al., filed Jun. 25, 2014.
Notice of Allowance Mailed Feb. 26, 2016 of U.S. Appl. No. 13/957,259 by Shaashua, T.M., et al., filed Aug. 1, 2013.
Pal, A. et al., "Intelligent Social Network of Devices," Computational Social Networks: Tools, Perspectives and Applications, 2012, pp. 329-348.
U.S. Appl. No. 15/181,191 of Shaashua et al. filed Jun. 13, 2016.
Notice of Allowance mailed Jan. 13, 2017, for U.S. Appl. No. 14/315,031 of Shaashua et al. filed Jun. 25, 2014, 7 pages.

* cited by examiner

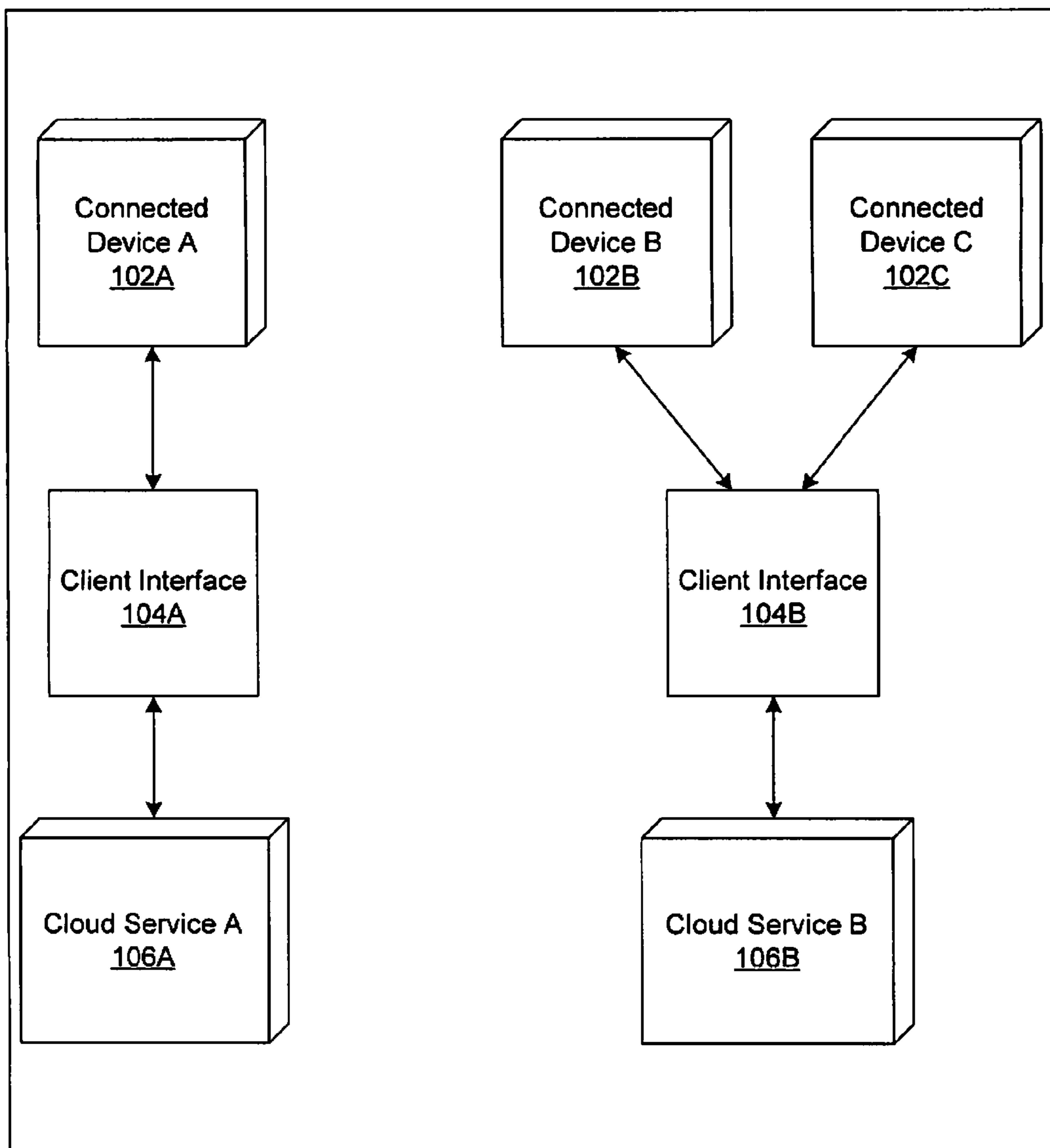

FIG. 1A

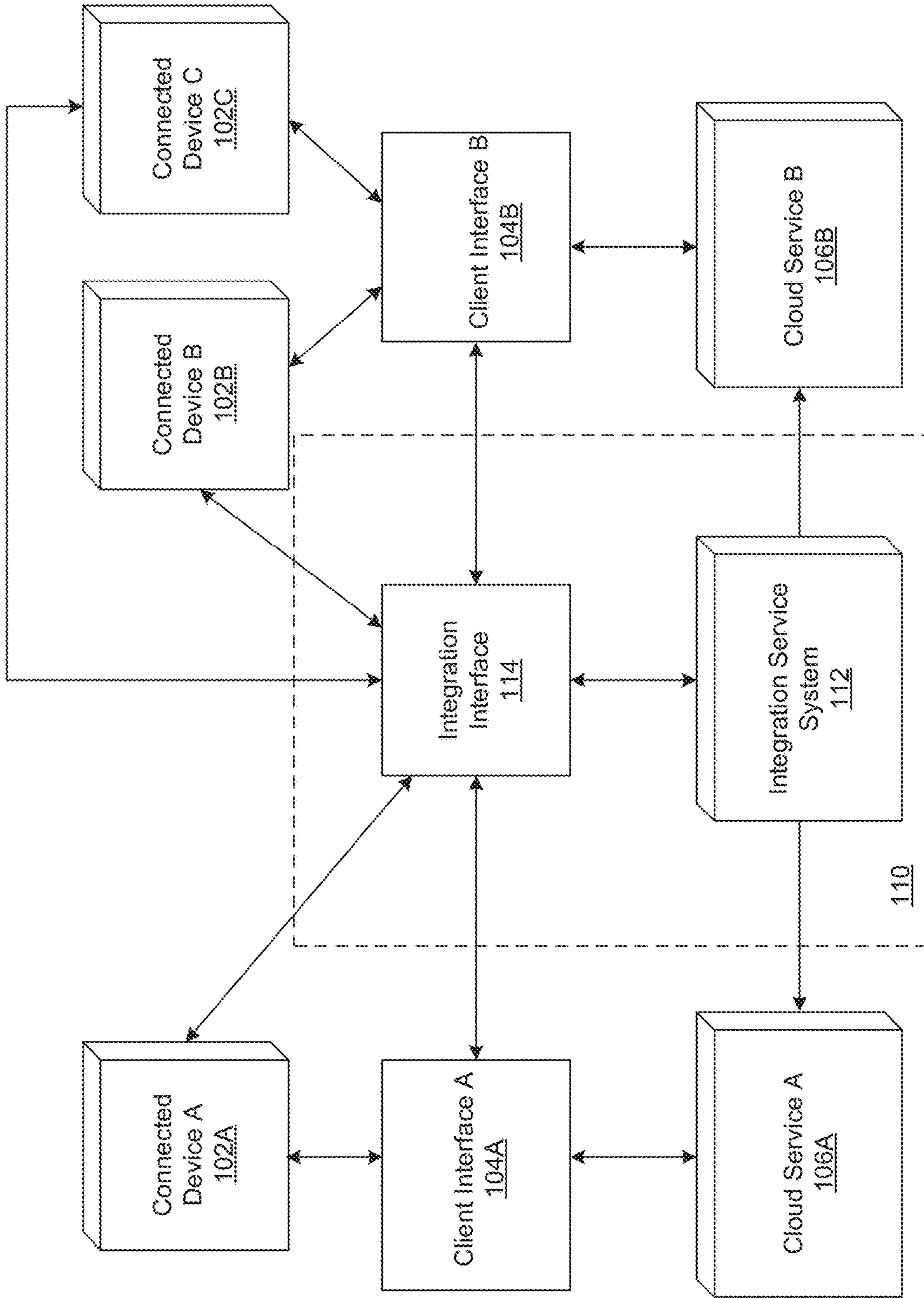

FIG. 1B

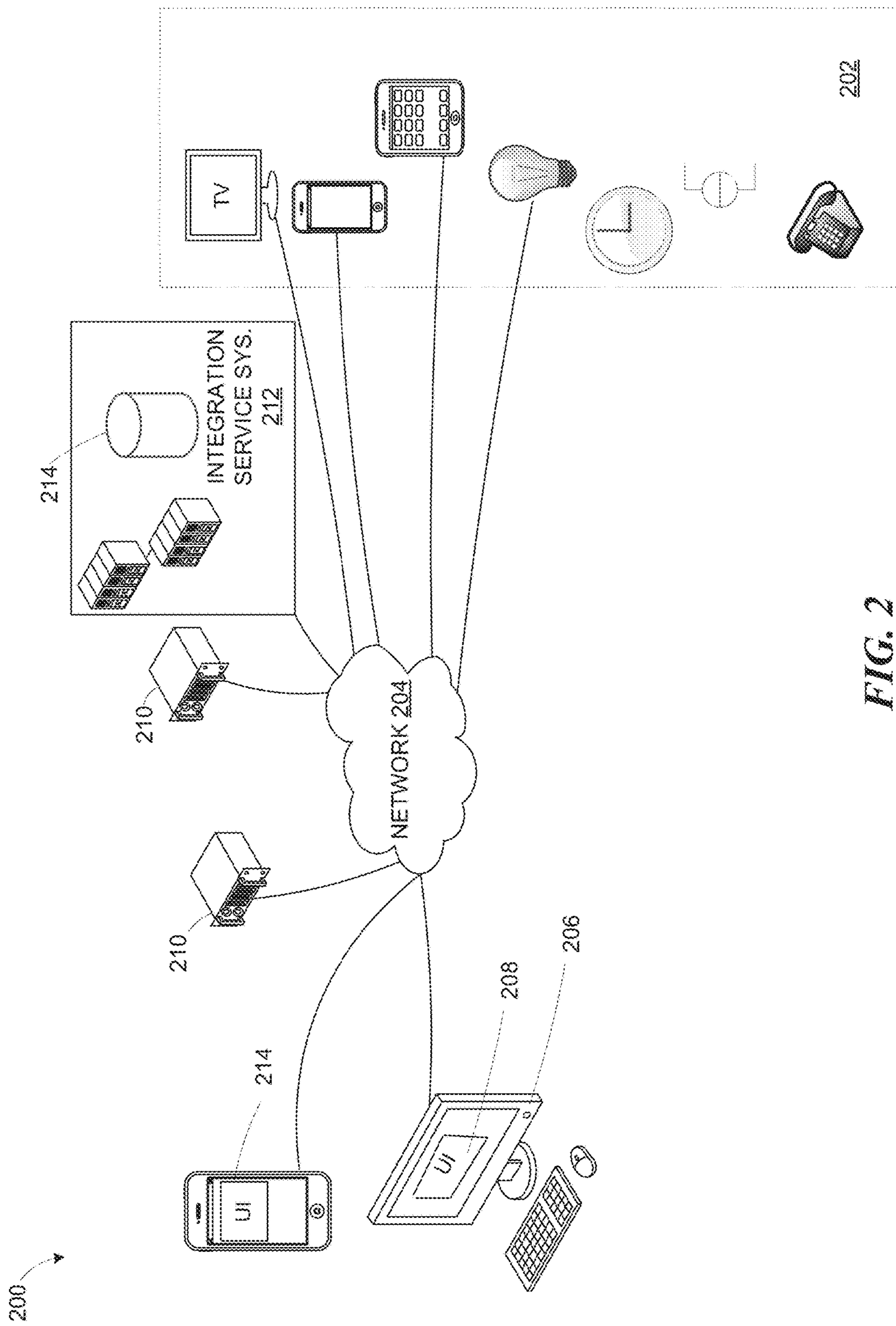

FIG. 2

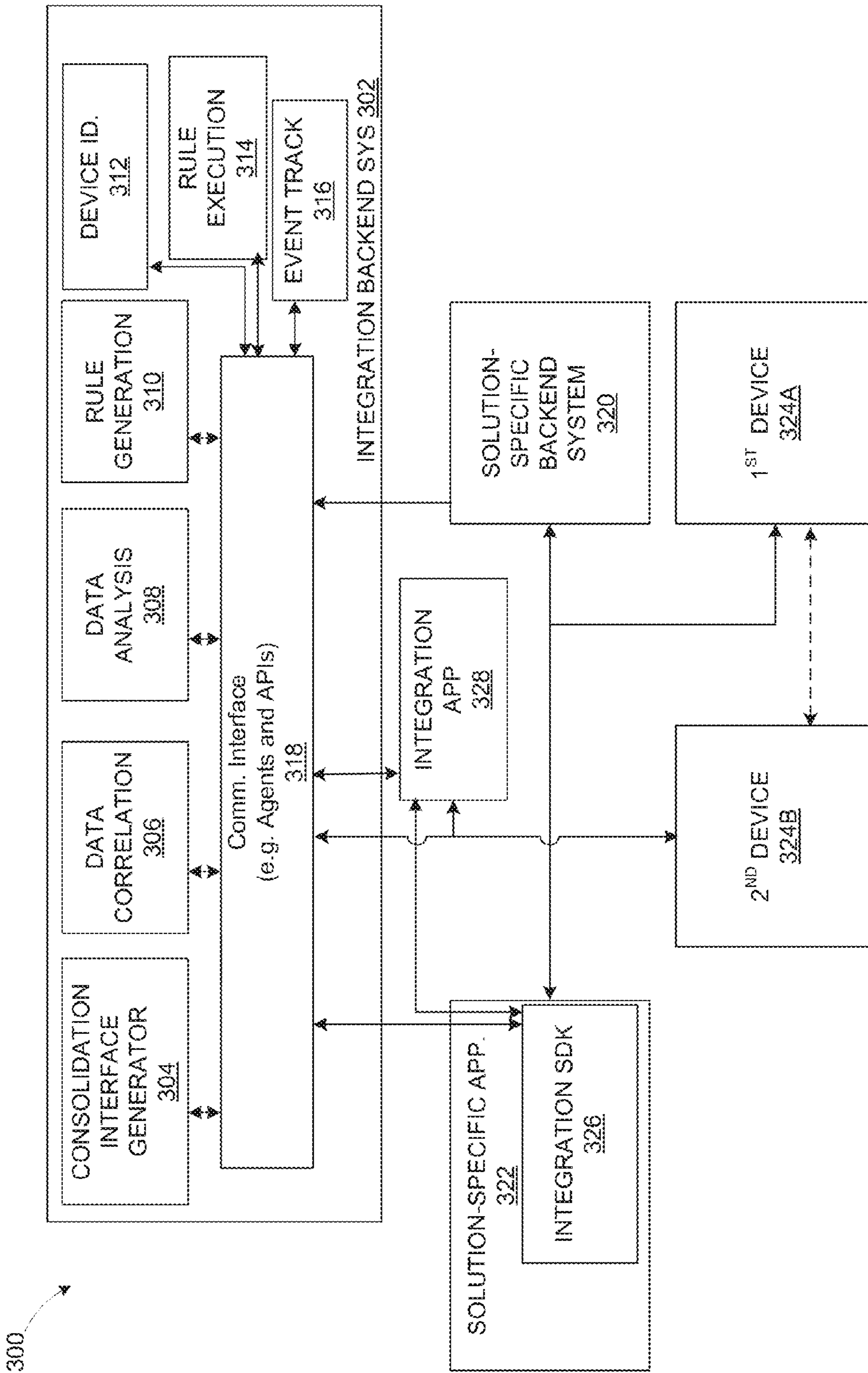

FIG. 3

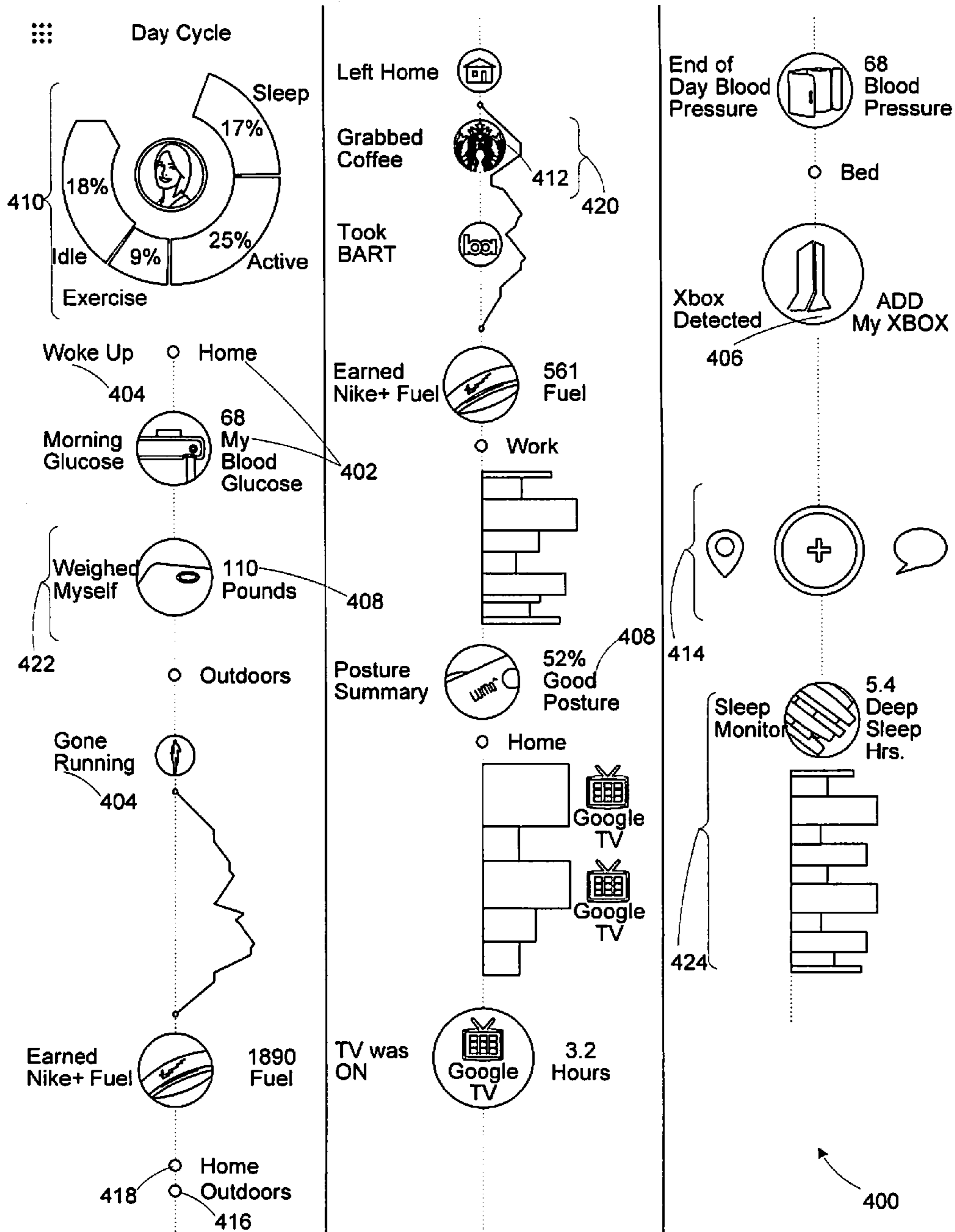

FIG. 4

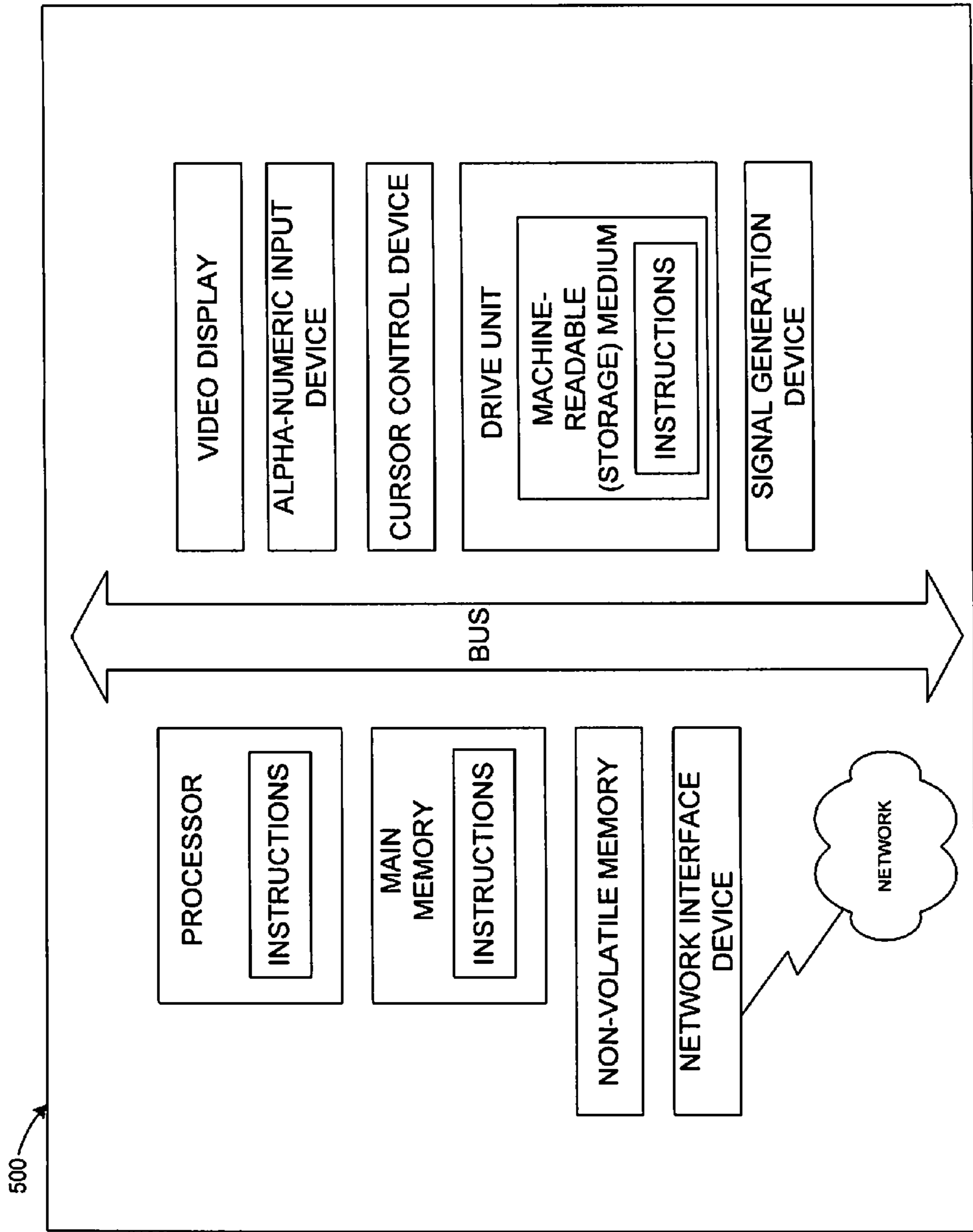

FIG. 5

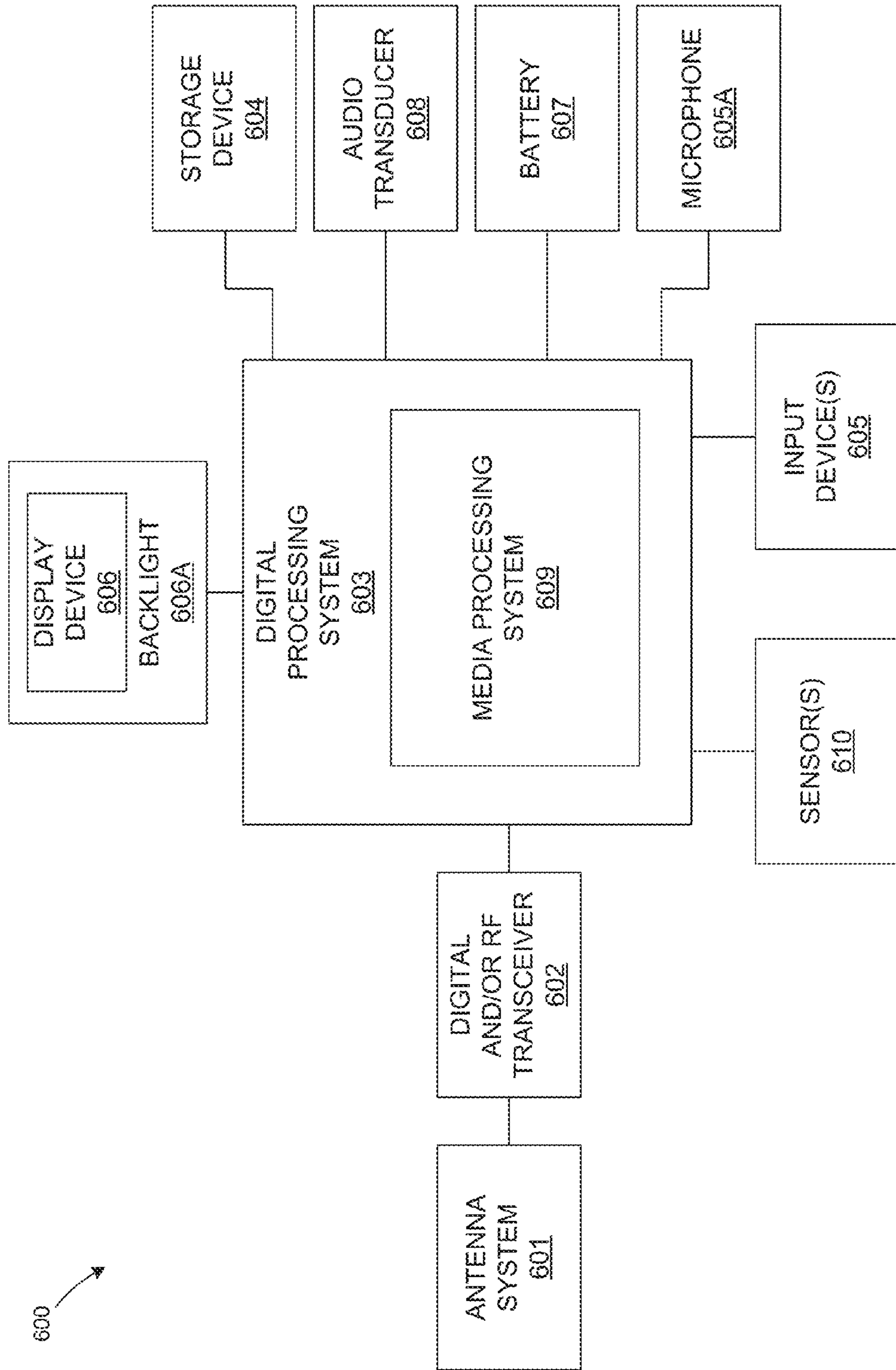

FIG. 6

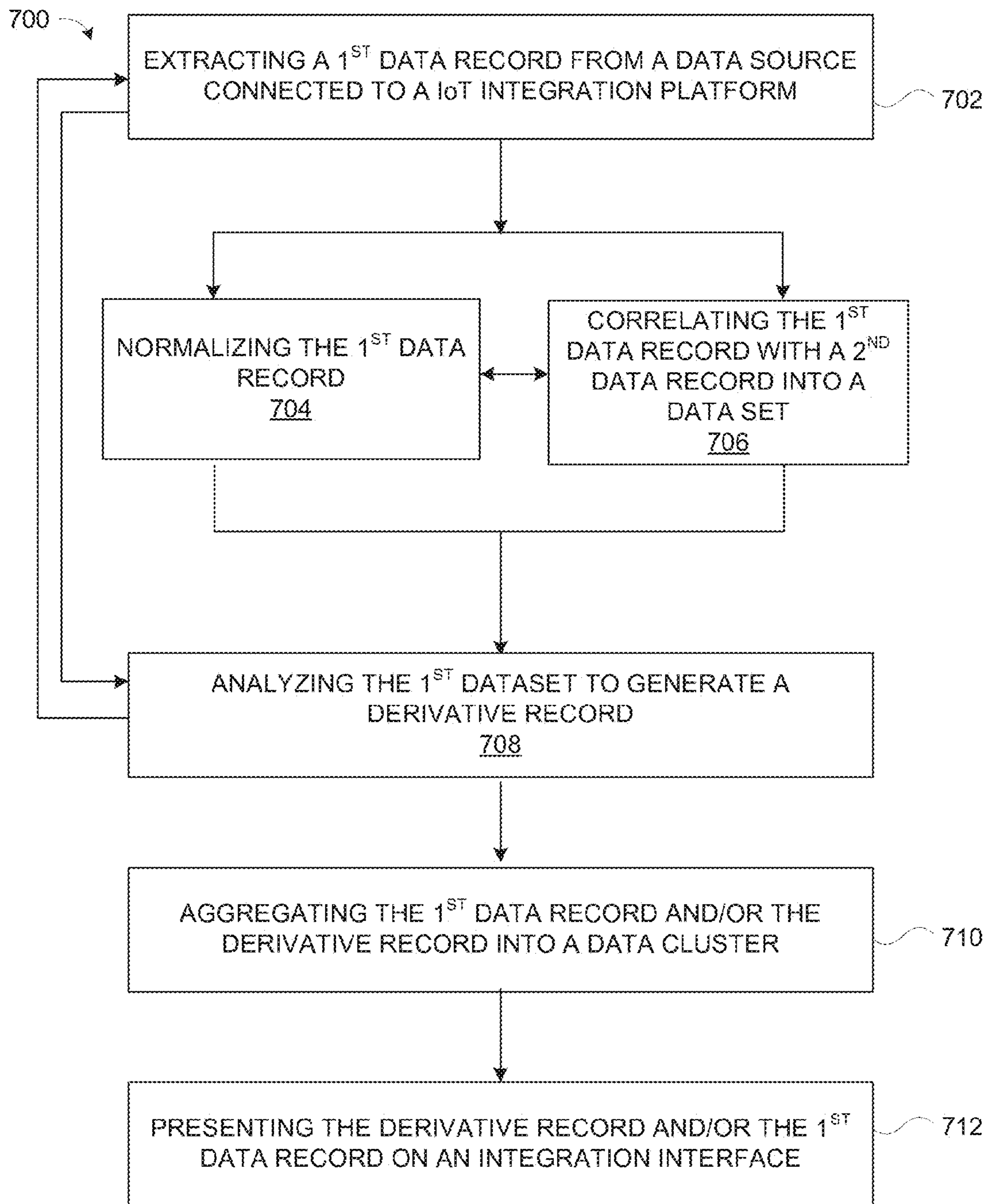

FIG. 7

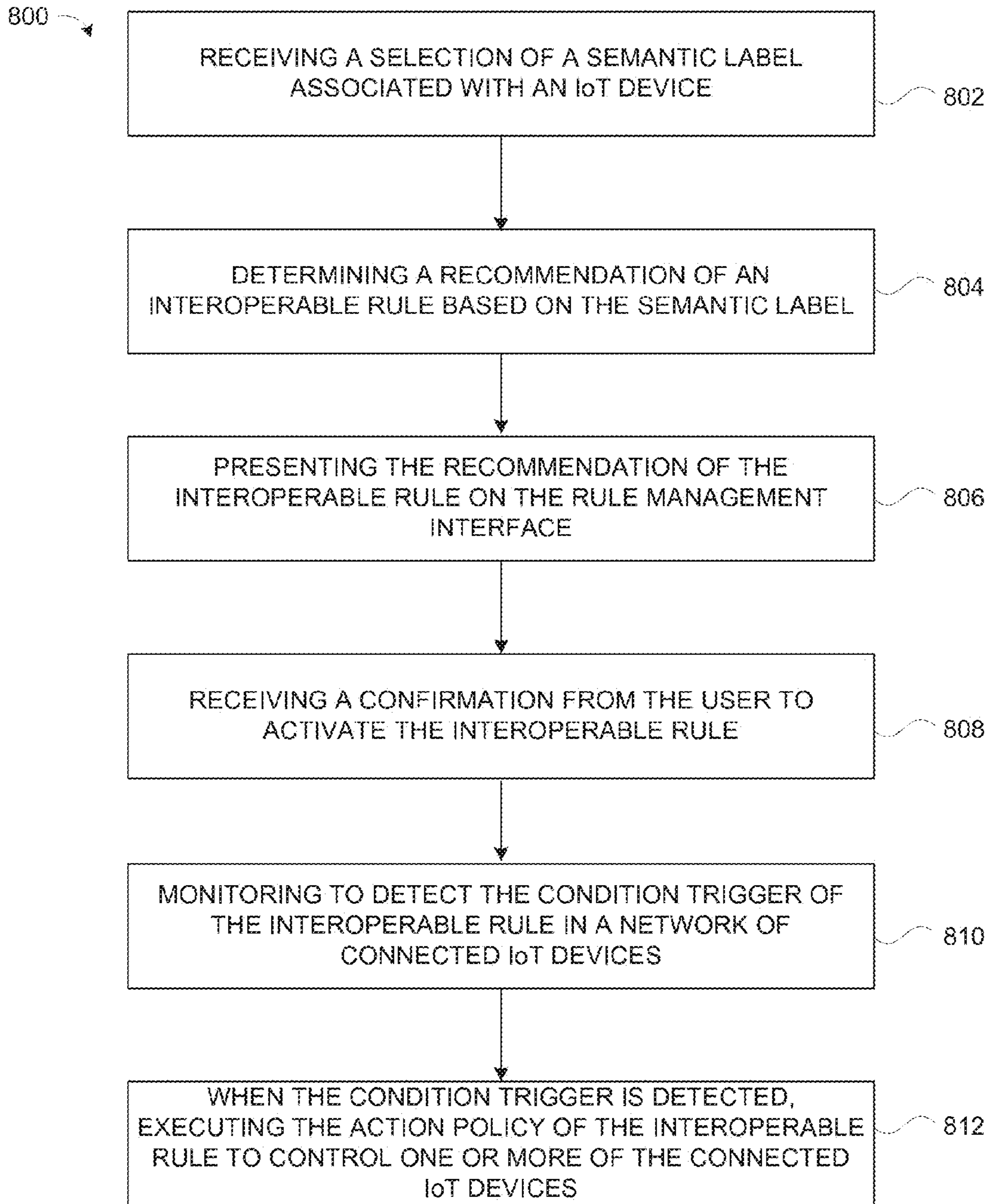

FIG. 8

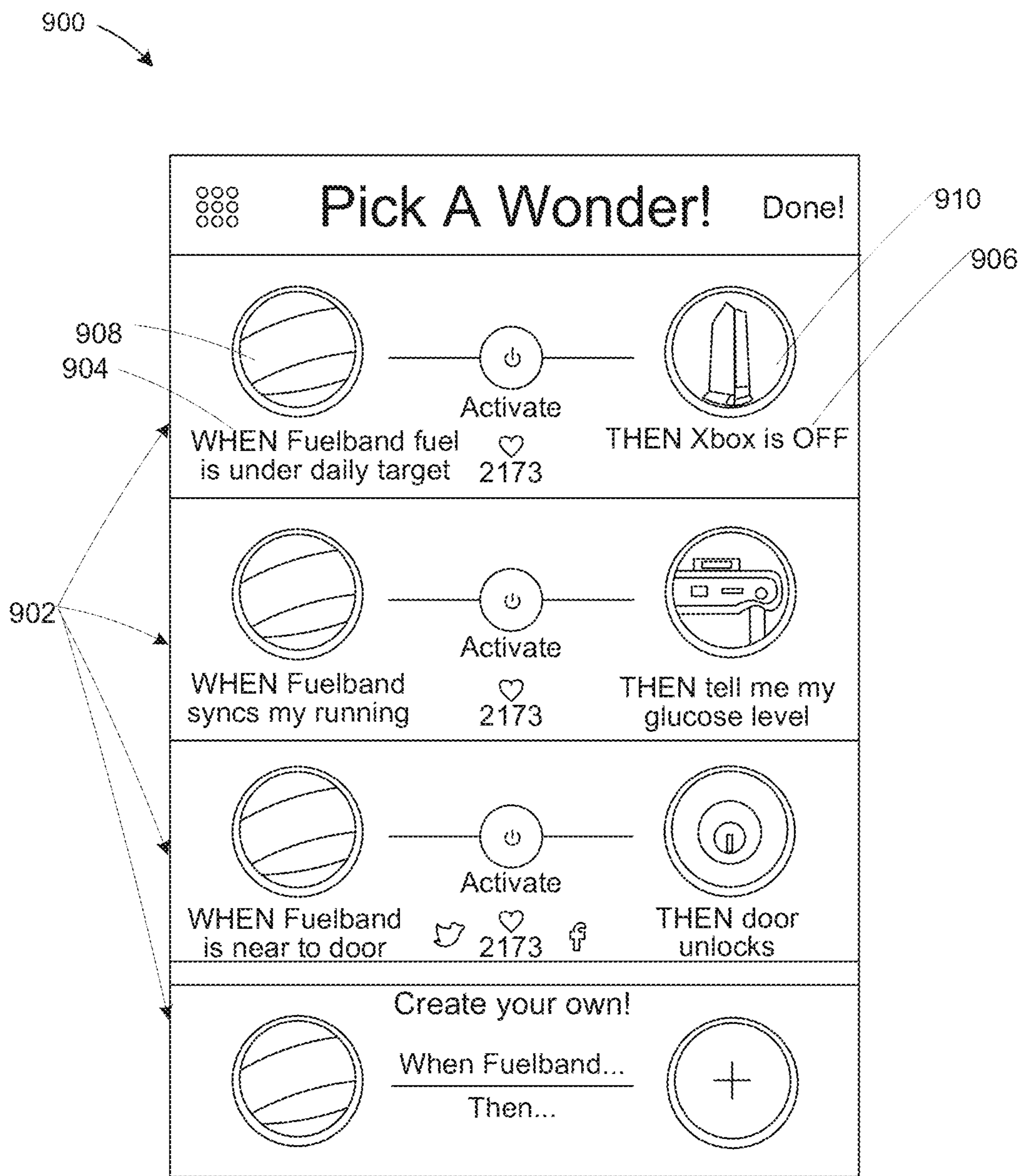

FIG. 9A

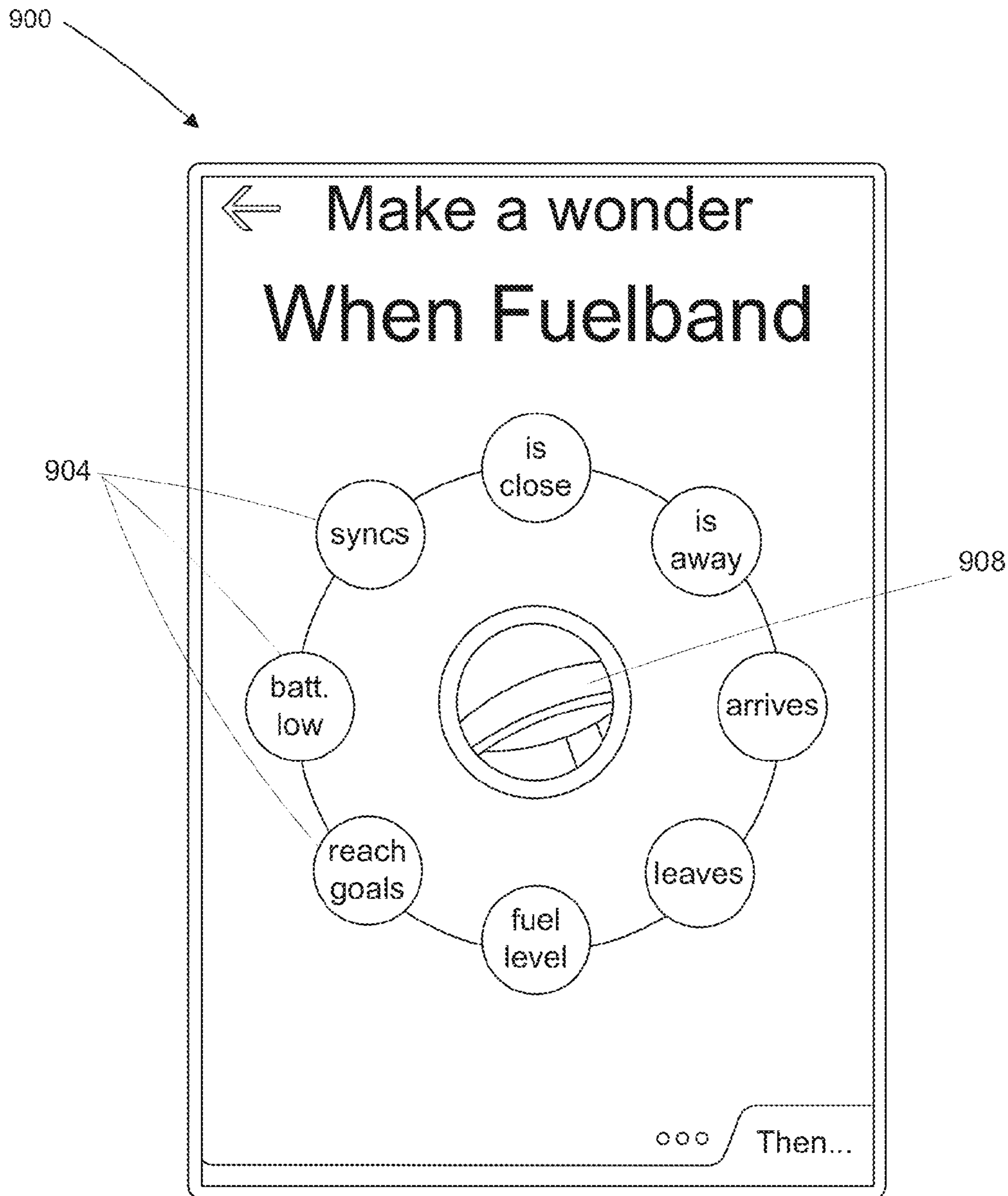

FIG. 9B

900

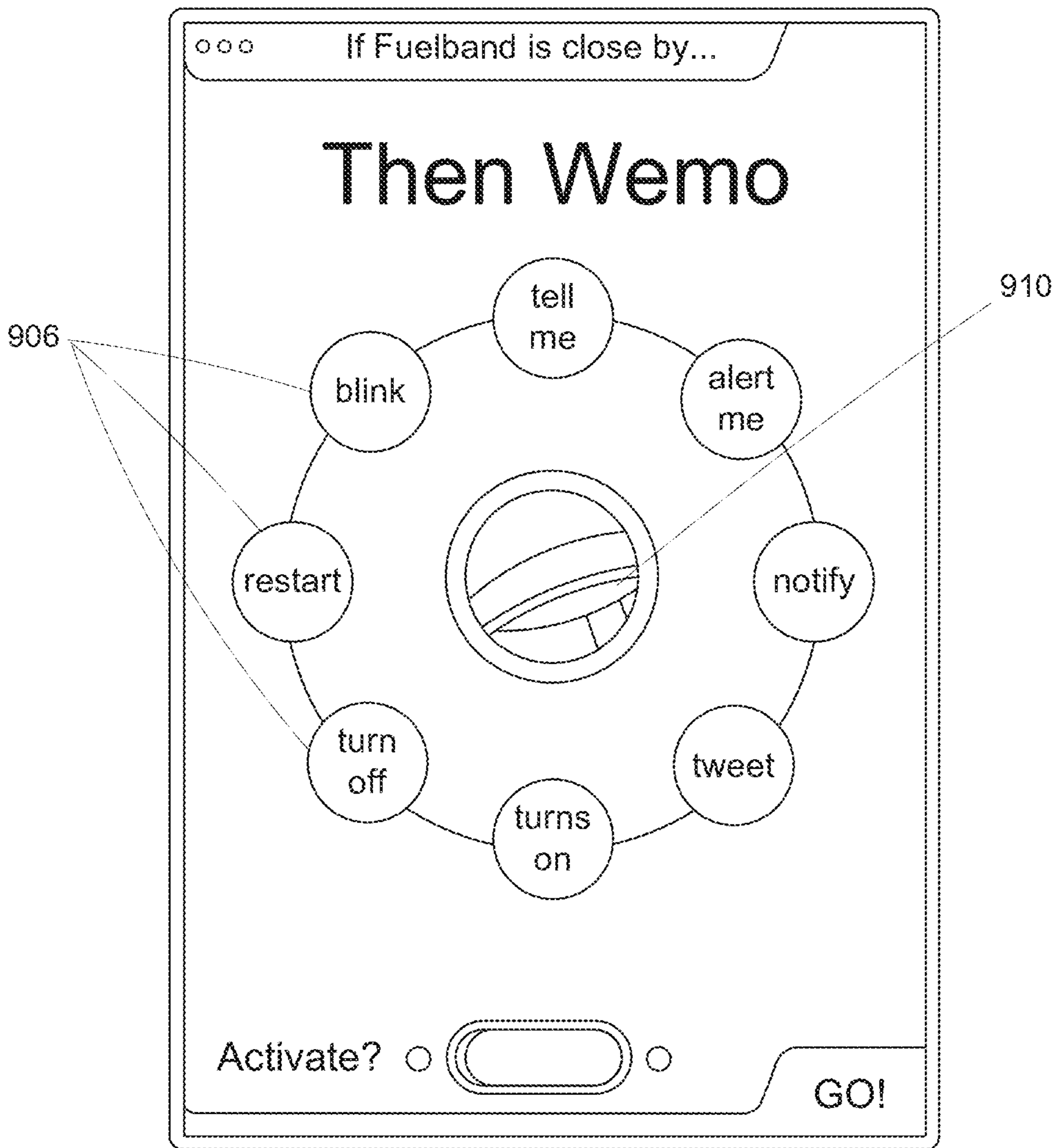

FIG. 9C

1000

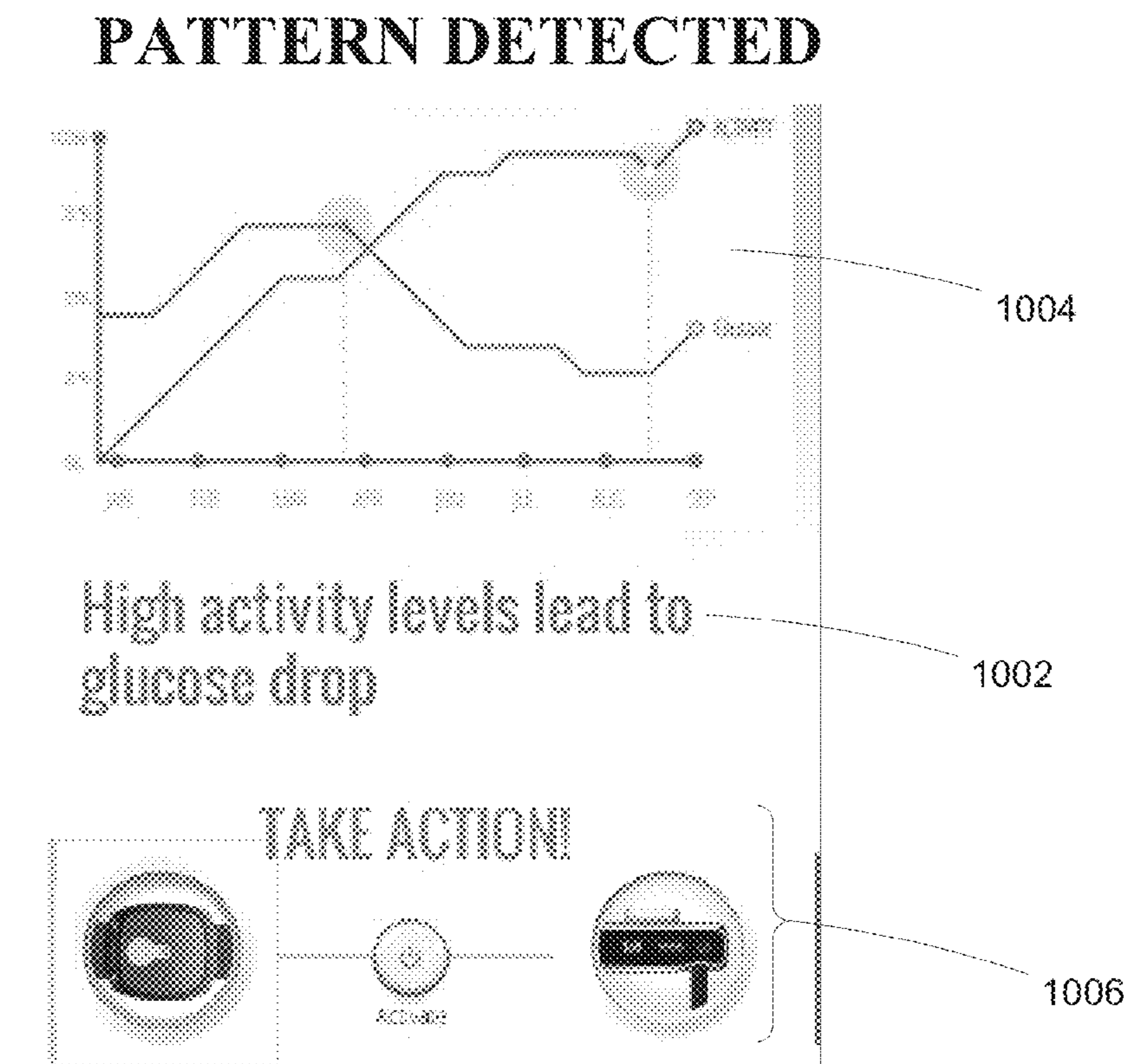

FIG. 10A

1050

CORRELATE & ACT

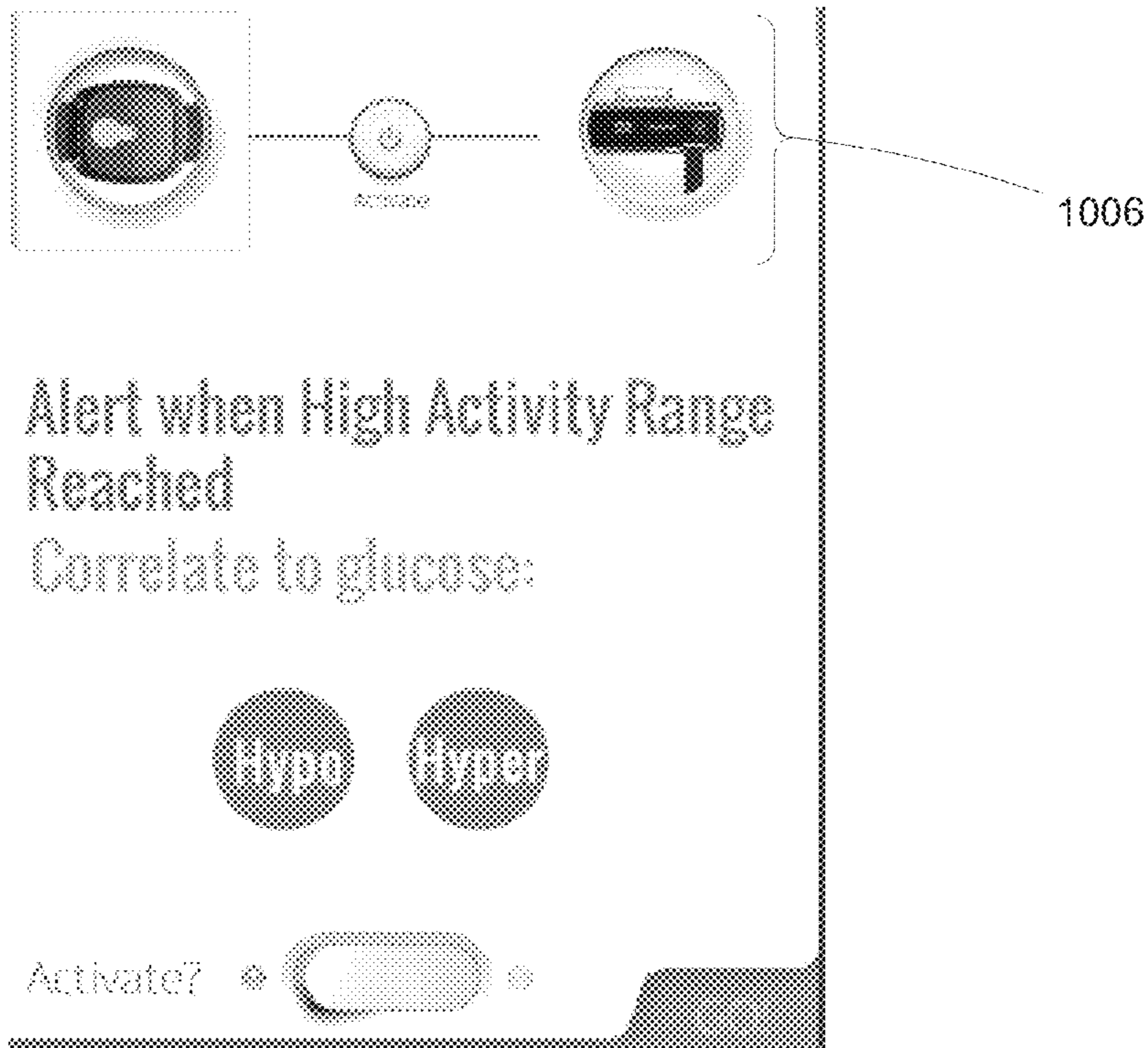

FIG. 10B

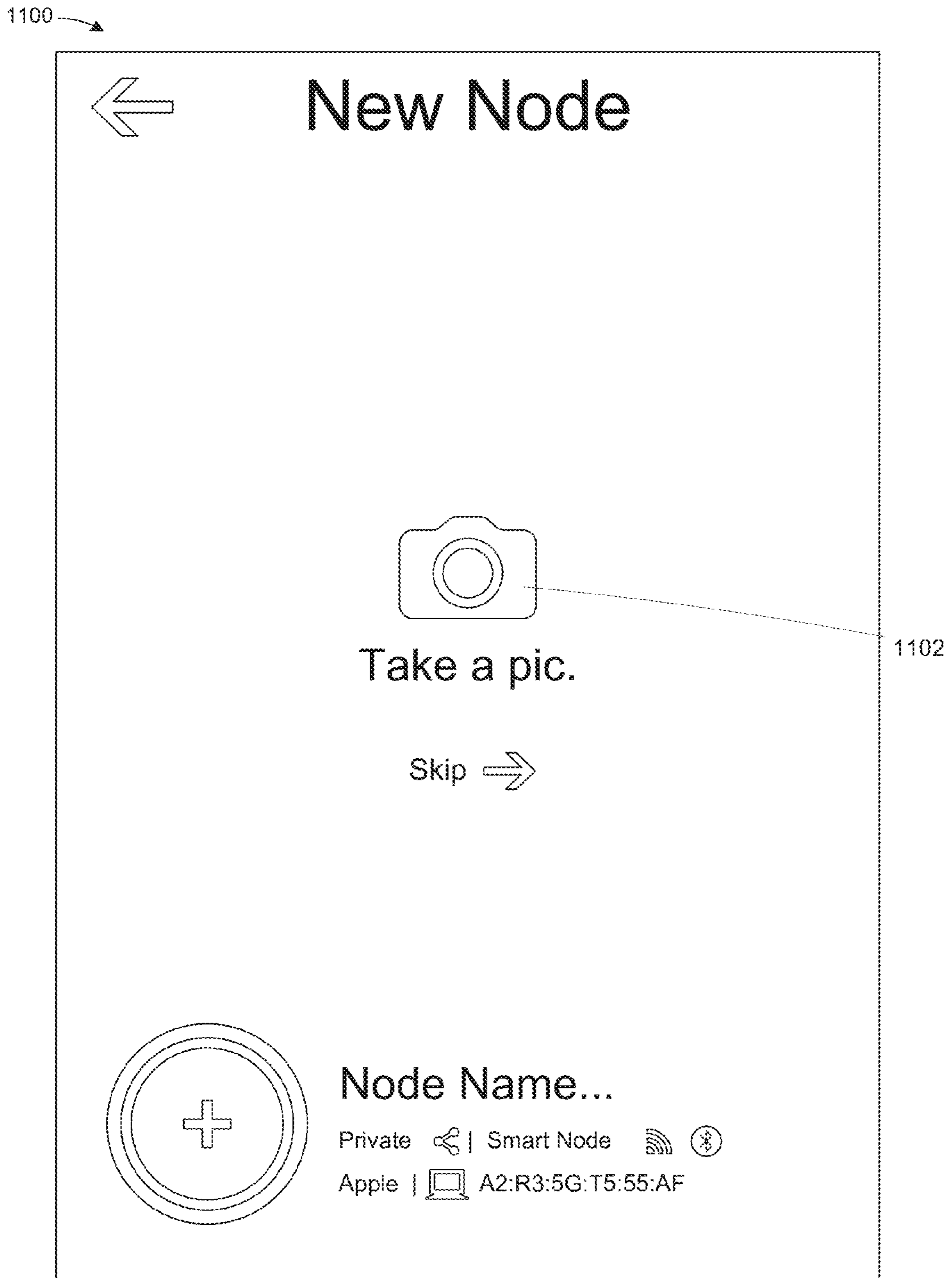

FIG. 11A

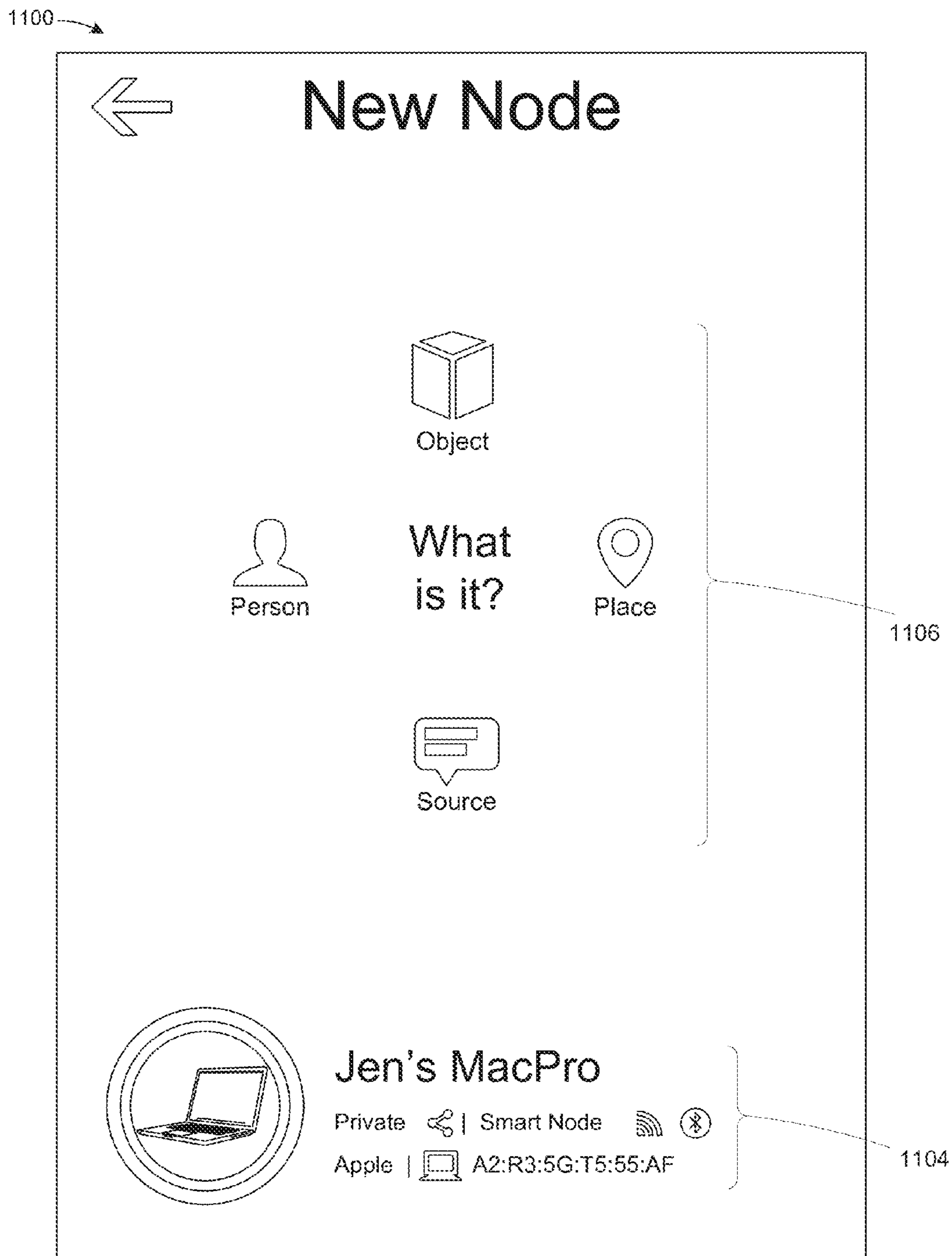
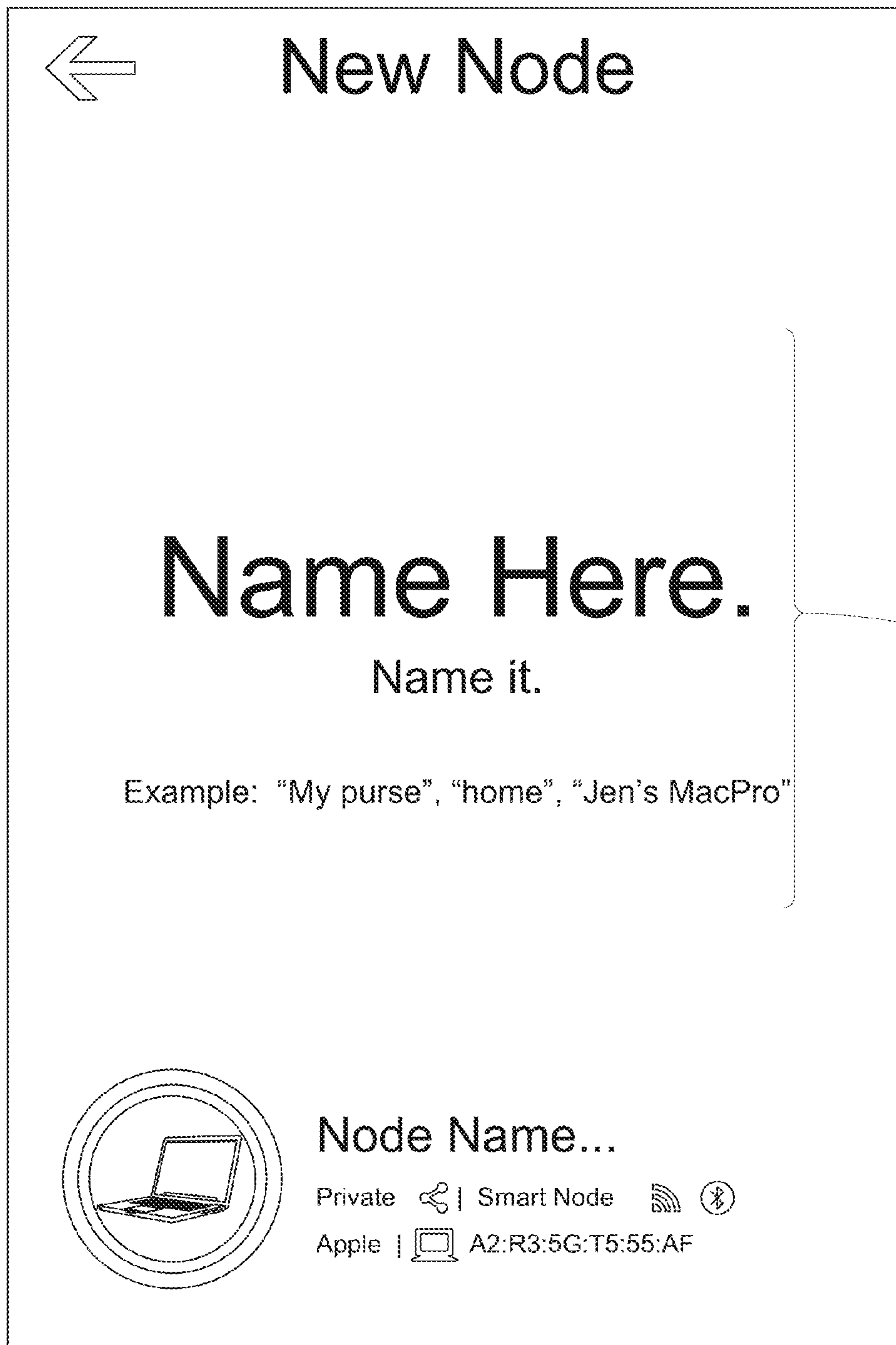

FIG. 11B

1100



1108

FIG. 11C

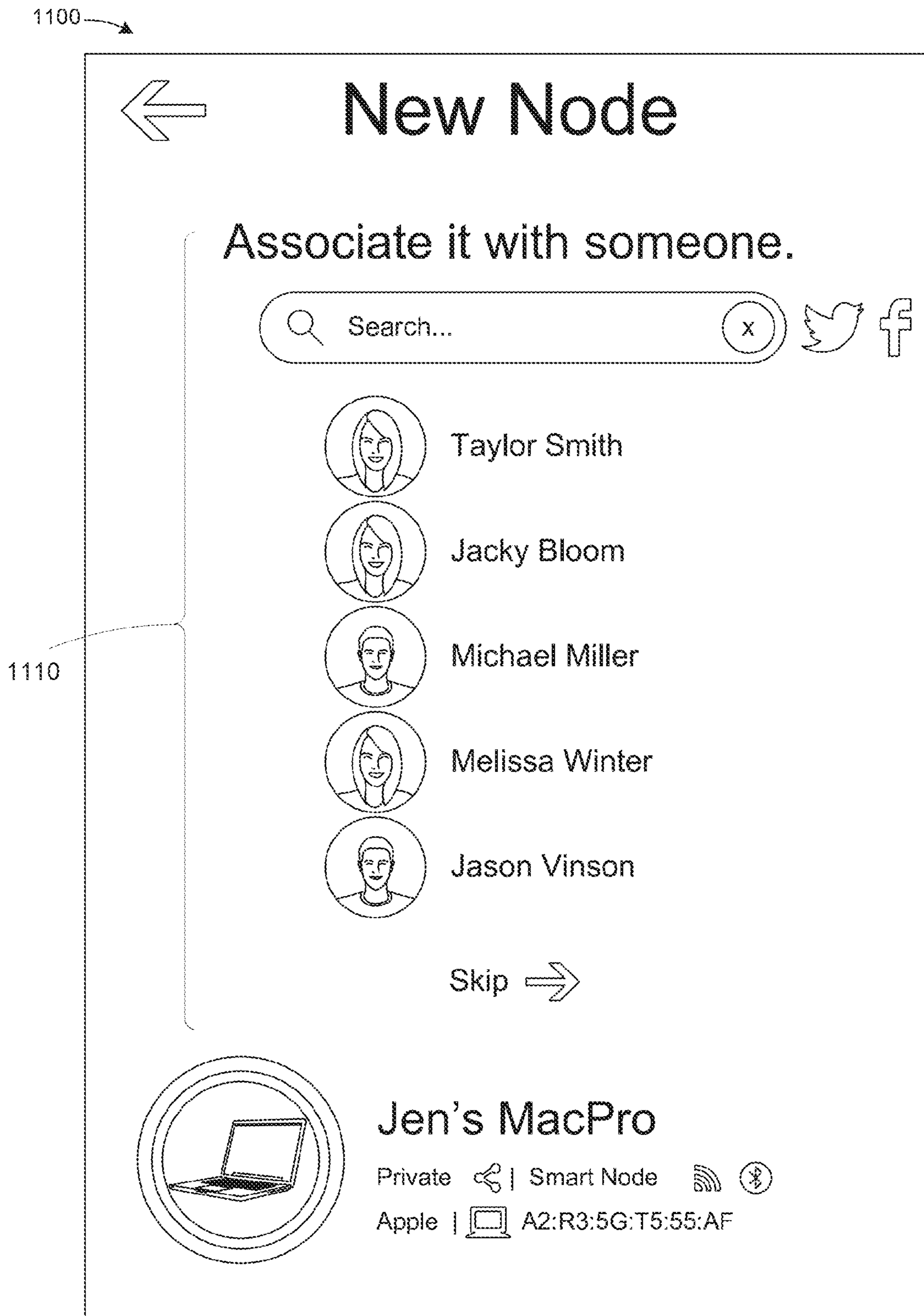

FIG. 11D

INTEROPERABILITY MECHANISMS FOR INTERNET OF THINGS INTEGRATION PLATFORM

CROSS-REFERENCE TO RELATED APPLICATION

This application claims the benefits of U.S. Provisional Patent Application Ser. No. 61/845,369 filed Jul. 11, 2013, and the subject matter thereof is incorporated herein by reference in its entirety.

FIELD OF INVENTION

This invention relates generally to the technical areas of the Internet of Things.

INTRODUCTION

The Internet of Things (IoT) refers to uniquely identifiable devices and their virtual representations in an Internet-like structure. The concept of IoT devices includes networked devices (“connected devices”) capable of communicating with a server or with a mobile application via a network connection other devices (“connected device”). The networked devices may include passive and active devices, where the passive devices may achieve network connectivity through interactions with the active devices. IoT devices are intended to achieve ubiquitous connection for intelligent perception, identification and management of items and processes. Many considers IoT as the third wave of development of information industry following the computer and the Internet. However, solutions for management of IoT devices are generally vertical solutions.

DISCLOSURE OF TECHNOLOGY

Disclosed is a technology for creating an integration platform for the Internet of Things (“the technology”). The technology further enhances the integration platform to connect to not only devices, but also other physical entities, such as places and people (“Internet of Everything”). The technology is a consumer solution to consolidate and automate users’ connected environment. The technology can identify and profile connected devices around a consumer, communicate with the connected devices, and create logical connections amongst people, devices, locations, digital channels, or any combination thereof.

The technology may be implemented by the integration platform. The integration platform may include a consolidation interface, a data correlation module, a data analysis module, and a rule development module. The consolidation interface is a centralized interface accessible via one or more of the networked devices. The consolidation interface may include a rule creation interface. The consolidation interface may include an interactive visual component including an interactive user interface and visual recognition of places, situations, and people, an interactive audio component including voice control, an interactive gesture component, or any combination thereof. The consolidation interface provides a single interface to view/edit consolidated data and to interact with the networked devices, such as via the rule creation interface. The data correlation module associates data and metadata from the networked devices to relate these data and/or metadata to a user. The data analysis module analyzes the collected data and metadata to determine spe-

cific semantic label or context relevant to the user. The rule management module enables configuration, adjustments, and interactions with the networked devices based on user-profile, context, event trigger, user behavior, social interactions, user configurations, or any combination thereof.

The rule management module may embody these configurations, adjustments, and interactions in one or more interoperable rules. These interoperable rule may be executed on the connected devices. The interoperable rules may be implemented in reference to any node, such as any person, place, device, group, or other entity, thing or object. Because of context recognition as enabled by the data analysis module, the one or more interoperable rules for each node may be designed and manipulated in context.

Some embodiments of the invention have other aspects, elements, features, and steps in addition to or in place of what is described above. These potential additions and replacements are described throughout the rest of the specification

BRIEF DESCRIPTION OF THE DRAWINGS

FIG. 1A is a block diagram illustrating vertical solutions provided for connected devices.

FIG. 1B is a block diagram illustrating an integration platform operating in conjunction with the vertical solutions.

FIG. 2 is a block diagram illustrating an example system environment of a internet of things (IoT) integration platform system.

FIG. 3 is a block diagram illustrating the IoT integration platform system.

FIG. 4 is an example of an user interface illustrating an active lifeline diagram for a user account on an integration interface, consistent with various embodiments of the disclosed technology

FIG. 5 is a diagrammatic representation of a machine in the example form of a computer system within which a set of instructions, for causing the machine to perform any one or more of the methodologies or modules discussed herein, may be executed.

FIG. 6 is a diagrammatic representation of a wireless device.

FIG. 7 is a flow diagram of a method of data consolidation, consistent with various embodiments of the disclosed technology.

FIG. 8 is a flow diagram of a method of interoperable IoT rule management, consistent with various embodiments of the disclosed technology.

FIG. 9A is an exemplary screen shot illustrating a rule management interface of an integration platform at a rule activation stage, consistent with various embodiments of the disclosed technology.

FIG. 9B is an exemplary screen shot illustrating the rule management interface of the integration platform at a condition selection stage, consistent with various embodiments of the disclosed technology.

FIG. 9C is an exemplary screen shot illustrating the rule management interface of the integration at an action selection stage, consistent with various embodiments of the disclosed technology.

FIG. 10A is an exemplary screen shot illustrating the consolidation interface showing a correlative insight, consistent with various embodiments of the disclosed technology.

FIG. 10B is an exemplary screen shot illustrating the consolidation interface generating an interoperable rule

from the correlative insight, consistent with various embodiments of the disclosed technology.

FIG. 11A is an exemplary screen shot illustrating a semantic camera interface at a first stage, the semantic camera interface used in conjunction with a life line diagram, consistent with various embodiments of the disclosed technology.

FIG. 11B is an exemplary screen shot illustrating the semantic camera interface at a second stage, the semantic camera interface used in conjunction with a life line diagram, consistent with various embodiments of the disclosed technology.

FIG. 11C is an exemplary screen shot illustrating the semantic camera interface at a third stage, the semantic camera interface used in conjunction with a life line diagram, consistent with various embodiments of the disclosed technology.

FIG. 11D is an exemplary screen shot illustrating the semantic camera interface at a fourth stage, the semantic camera interface used in conjunction with a life line diagram, consistent with various embodiments of the disclosed technology.

The figures depict various embodiments of the technology for purposes of illustration only. One skilled in the art will readily recognize from the following discussion that alternative embodiments of the structures and methods illustrated herein may be employed without departing from the principles of the technology described herein.

DETAILED DESCRIPTION

Integration

Every day more and more newly connected devices are introduced into the market each offering a vertical solution with a specific functionality. All these various solutions do not communicate to each other. For example, FIG. 1A is a block diagram illustrating vertical solutions provided for connected devices, such as device-A 102A, device-B 102B, and device C 102C (collectively “devices 102”). Each connected devices service provider may have its own vertical solution with a client interface (e.g., mobile or web), such as interface-A 104A and interface-B 104B (collectively “interfaces 104”), and one or more cloud services for computation, such as cloud service-A 106A or cloud service-B 106B (collectively “cloud services 106”).

Different devices 102 use different communications protocols made by different manufacturers. The integration platform may act as single point of interaction enabling cross-device and cross technology communication. FIG. 1B is a block diagram illustrating an integration platform operating in conjunction with the vertical solutions. The integration platform may be implemented through communication integration, including an unified application programming interface (API), unified software development kit (SDK), unified protocol(s), and/or interoperability interfaces between different connected devices. The integration platform mainly can be implemented by an integration service system 112 (e.g., the computer system 500 of FIG. 5) and an integration interface 114 (e.g., mobile or web). The integration service system 112 may provide different services for integration of the IoT devices 102 and for providing an execution environment for applications related to the use of the IoT devices 102. The integration interface 114 may be a software application that runs on a local computing device that is capable of managing or integrating the IoT devices 102 within a local network.

System Environment

FIG. 2 is a block diagram illustrating an example system environment of an internet of things (IoT) integration platform system 200. The IoT integration platform system 200 includes IoT devices 202, such as the IoT devices 102 of FIG. 1. IoT devices 202, for example, can be smart phones, smart watches, smart sensors (e.g., mechanical, thermal, electrical, magnetic, etc.), networked appliances, networked peripheral devices, networked lighting system, communication devices, networked vehicle accessories, smart accessories, tablets, smart TV, computers, smart security system, smart home system, other devices for monitoring or interacting with or for people and/or places, or any combination thereof. The IoT devices 202 may include the wireless device 600 of FIG. 6. The IoT devices 202 may include one or more of the following components: sensor, radio frequency identification (RFID) technology, global positioning system technology, mechanisms for real-time acquisition of data, passive or interactive interface, mechanisms of outputting and/or inputting sound, light, heat, electricity, mechanical force, chemical presence, biological presence, location, time, identity, other information, or any combination thereof.

The IoT device 202 are connected via a network 204. The network 204 may include different channels of communication and may include local networks therein. For example, the network 204 may include wireless communication through cellular networks, WiFi, Bluetooth, Zigbee, or any combination thereof. The network 204 may include one or more switches and/or routers, including wireless routers that connect the wireless communication channels with other wired networks (e.g., the Internet). A local network may exist that connects a local set of the IoT device 202. For example, the local network may be established by a local router or a local switch.

For example, the IoT device 202 may be connected to a control device 206 within the local network. The control device 206 may be a computer, a networked device, or a mobile device, such as the wireless device 600. The control device 206 may include an interface implemented by a solution-specific application 208. An IoT device may be coupled to the solution-specific application 208, where the solution-specific application 208 is created specifically to communicate with such devices as part of a vertical solution. The solution-specific application 208 may be able to control the IoT device or to access data from the IoT device.

IoT devices may also communicate with a solution-specific service server system 210. For example, a networked lighting system may communicate with the solution-specific service system 210 keeping track of whether lights are on/off on the solution-specific service system 210. The solution-specific service system 210 can create an interface to share that data and/or to interact with the IoT devices. The interface may be accessible through the solution-specific application 208 or through a browser.

The technology disclosed includes an integration service system 212, such as the integration service system 112, and an integration interface 214, such as the integration interface 114, that can manage or integrate multiple instances of the IoT devices 202 and co-exist with the vertical solutions. The integration interface 214 may run on the control device 206. The integration interface 214 may be a computing application, a web page, other interactive interface operable on a computing device. The disclosed integration service system 212 and/or the integration interface 214 overcome the challenge of user inconvenience. Vendors who manufacture IoT devices 202 do not have a consistent standard to provide a

unified interface. The proposed system provide a technology including specific modules and processes to coordinate with the multiple IoT devices 202, the multiple solution-specific applications 208, and the multiple solution-specific service server systems 210.

The integration service system 212 may include a profile store 214 of IoT devices 202 and other context relevant entities. For example, context relevant entities may include people, places, groups, physical objects, brands, things, or any combination thereof. Some of the context relevant entities in the integration service system 212 may not include any networking capabilities, but may be observed through the connected IoT devices 202 either directly or indirectly. The integration service system 212 may profile these entities, such as via a data analysis module 308 described below in FIG. 3, and store these entity profiles in the profile store 214 for reference. Interaction with these profiled entities may be enabled by visual identification (e.g., image recognition), voice recognition, motion detection, geo-location, other input data to the IoT devices 202, or any combination thereof.

As an example, an IoT device 202 with a camera can recognize a known user is in front of a plate and fork (e.g., within a context of “eating”). Such recognition may trigger an increase of the known user’s target daily steps in his/her activity monitor (e.g., due to higher calorie intake), or trigger the known user’s coffee machine to prepare an espresso. In this example the plate and fork do not have network capability, but do have profiles in the profile store 214. The recognition of the profiles may be a trigger for an action in the connected devices.

As another example, detecting proximity to a person (e.g., a child) or a place (e.g., a child’s room) may trigger wearable IoT devices 202 (e.g., sensors) on the child to synchronize relevant data to the integration service system 212, such as the child’s glucose level. The integration service system 212 may respond to this trigger by analyzing the relevant data, and visualizing a relevant correlative insight (e.g., “inject more insulin”) based on the analyzed data on a parent’s smartphone or wearable device. The integration service system 212 may further execute an interoperable rule upon detection of the trigger, such as by sending a command to another IoT device (e.g., an insulin pump). In this example, the trigger may be based on a contextual or semantic profiling of a person or place, and not necessarily another device.

System Architecture

FIG. 3 is a block diagram illustrating the IoT integration platform system 300. The modules therein may be implemented by a computer system, such as the computer system 500 of FIG. 5. The IoT integration platform system 300 may include an integration backend system 302, such as the integration service system 212 of FIG. 2. The integration backend system 302 may include a consolidation interface generator 304, a data correlation module 306, a data analysis module 308, a rule generation module 310, a device identification module 312, a rule execution module 314, and an event track module 316. The integration backend system 302 may also include a communication interface module 318 for interfacing with the IoT devices and/or client interfaces.

The IoT integration platform system 300 may enable integration of vertical solutions of IoT devices, such as the vertical solutions illustrated in FIG. 1A and FIG. 1B. For example, a vertical solution may include a solution-specific backend system 320, a solution-specific application 322, and/or a first IoT device 324A. For example, the first IoT device 324A may communicate with the solution-specific

backend system 320 and/or the solution-specific application 322 as part of the vertical solution. The IoT integration platform system 300 enables a second IoT device 324B to become connected, even though the second IoT device 324B is not part of the vertical solution. Collectively, the connected devices including the first and second IoT devices 324A and 324B may be referred to as “the IoT devices 324.” The technology to implement such integration may be achieved via the integration backend system 302, an integration application 328, such as the integration interface 214 of FIG. 2, or both. In various embodiments, any one or more of the modules of the integration backend system 302 may be implemented within the integrated application 328.

For example, integration may be achieved in any combination of the following methods, including cloud-based integration, mobile-based integration, and device-based integration. The integration method may depend on the manufacture of each of the IoT devices 324. Regardless of the integration method, the integration backend system 302 and/or the integration application 328 are informed of the existence of any newly connected IoT device.

For cloud-based integration, the communication interface module 318 enables communication between or amongst the integration backend system 302 and one or more of the solution specific backend systems 320. For mobile-based integration, the integration application 328 may communicate with the solution-specific application 322. For example, this communication may be achieved by providing an integration SDK 326 to the solution-specific application 322 and/or the integration application 328. For device-based integration, the integration application 328 may communicate with the IoT devices 324 belonging to different vertical solutions via an open protocol. For example, the integration application 328 may scan different local networks (e.g., Wi-Fi, Bluetooth, BlueTooth Low Energy, Zigbee, etc.), identify the IoT devices 324, and connect to control interfaces of each of the IoT devices 324.

For example, the communication interface module 318 may include an agent for communicating with an API on the solution-specific backend system 320. Alternatively, the communication interface module 318 may include an API of its own, and may allow the solution-specific backend system 322 to send/retrieve data, including real-time data, context data, sensor data, sensor metadata, configuration data, or any combination thereof, through the API.

As another example, the integration SDK 326 can embed communication processes/protocols for communicating with the communication interface module 318 of the integration backend system 302 and/or the integrated application 328. In some embodiments, the integrated application 328 may be distributed from the integration backend system 302. For example, the IoT devices 324 that have Wi-Fi connectivity may become visible to the integration platform 300 when in the Wi-Fi networks where the integration application 328 is connected.

As yet another specific example, an IoT device 324, such as the second IoT device 324B may integrate directly with the integration backend system 302 and/or the integrated application 328. The second IoT device 324B may be configured such that the protocols and processes for communicating with the integration backend system 302 and/or the integrated application 328 are stored thereon. Optionally, a device integration SDK (not shown), similar to the integration SDK 326, may be configured within an IoT device 324. The integration device SDK may enable the IoT devices 324 to communicate with the integration backend system

302, the integrated application 328, and/or with each other (shown as a dotted line connection).

Device Identification

The device identification module 312 is configured to generate a unique ID for each IoT device detected by the integration platform 300. The unique ID enables tracking of the IoT devices for the purposes of authentication, data access permissions and security, data correlation, data analysis, rule generation, rule execution, event tracking, and/or user interface. In some embodiments, the device identification module 312 may also detect the type and/or make of the IoT devices. The type may define the data structure of the IoT device, actions that are applicable to IoT device, and/or communication protocols and processes of the IoT device. As a specific example, correlating device features of a smart home automation light switch enables the data consolidation modules to communicate with the light switch and the interoperable rule modules to control and manage the light switch. The device identification module 312 can simplify the connectivity process of adding a new device by identifying the new device completely or partially without user input.

Identifying virtually and physically connected devices around a user or a place relevant to the user is an important component for the interoperability function. For example, the device identification module 312 may employ at least one of the following methods to identify the IoT devices 324: (a) device based identification, where unique IoT device identifier may be created based on the device's data elements; (b) protocol based identification, where unique device identifier may be created based on a device communication element or elements; (c) device and protocol based identification, where a combination of device data and communication protocol data may define the device identification; (d) device behavior based identification, where the device is identified based on its predefined or observed behavior, or any combination thereof. Behavior can be, for example, audible, visual, magnetic, electronic, motion, or any combination thereof. Behavior pattern can be passive or responsive to a command or stimulus. The device identification module 312 may recognize an IoT device behavior based on IoT device data, a test and verification command, or a context event associated with the IoT device. The test and verification command, for example, may include the device identification module 312 sending a blinking command to a connected light bulb in order to identify the exact bulb of multiple bulbs around. In this manner, the recognition of a context (e.g., behavioral context) and/or semantic circumstance of the IoT device (e.g., the light bulb) can define the unique identifier of the IoT device.

Device identification can be based on image recognition. Image-recognition-based device identification may be assisted by relevant data including contextual parameters from the data correlation module 306, the data analysis module 308, or both. For example, if the device identification module 312 analyzes a device and determines that the device may be either be a Samsung™ fridge or a Samsung™ TV, the device identity may be determined based on its geo-location context (e.g., if the device is in living room, then the device is a TV, and if the device is in kitchen, then the device is a fridge). In this case, for example, location may be determined through radio frequency (RF) beacons of other devices around or through geo-locating components. In the example of RF beaconing, if a microwave and coffee machine are detected around the device, then the device is probably in the kitchen. Location may further be assisted by semantic data. For example, if the device is proximate (e.g.,

within a distance threshold) to a bulb named by the user as “kitchen light”, then the device is in the kitchen. Proximity may be estimated by distance through router signal strength indication (RSSI) or visual recognition.

Data Consolidation

The task of data consolidation may be divided into steps. For example, data consolidation may be performed in the following steps including: (1) data extraction, (2) data aggregation, (3) data normalization, (4) data correlation, (5) data analysis, and (6) data visualization. An example of the data consolidation flow is illustrated in FIG. 7. The integration backend system 302 and/or the integration application 328 may implement any combination of the steps for data consolidation. For example, when a user operates an activity tracker and a network scale, the integration platform 300 enables a consolidated interface to present a correlative view of the user's weight and activities in a meaningful manner to assist the user in monitoring his/her health. The combination of the above steps enables unique correlation features that have been discovered to be advantageous. The data consolidation steps enable contextual and semantic insights based on a multitude of sensor/measurement/semantic/analytical/user-reported/device status data, rather than just a listing of sensor data. For example, the data consolidation may provide the user with health related insights of himself (e.g., when the user goes to work using public transport, the user burns four times more calories than when driving a car to work). Thus, the data consolidation steps may be used to motivate the user to change habits and behavioral patterns that affect his/her fitness/health. The data correlation module 306 is configured to extract raw data from different sources, including the IoT devices 324. For example, the data correlation module 306 can receive data (e.g., real-time from continuous or discrete data stream, non-real-time data, device sensor data, user-device interaction dataset, user reporting dataset, or any combination thereof including metadata thereof) from the IoT devices 324. For example, the data may include measurements, user commands, or user-reported status updates. The data correlation module 306 may receive the datasets directly from the IoT devices or via reporting from the solution-specific application 222 or the integrated application 328.

The data correlation module 306 may further be configured to extract raw data from an external source. For example, the raw data may be extracted from an online or virtual data source, such as a geo-location map, a social network, a calendar, a media network, or any combination thereof.

The data correlation module 306 may yet further be configured to extract data based on data analysis, such as the data analysis performed by the data analysis module 308. Data analysis may include semantic analysis and context awareness analysis. Further description of data generated from the data analysis module 308 is described herein.

The data correlation module 306 may be configured to aggregate the datasets into meaningful data buckets during the process of data collection. As data is extracted, the data is organized into the meaningful buckets (e.g., cluster). The data aggregation may be based on a time line, based on user, based on device type, based on user-defined groups, based on location, or any combination thereof.

The data correlation module 306 may be configured to normalize each of the datasets. For example, data along the same dimension may be normalized across time periods, across the data buckets through aggregation, or a combination thereof.

The data correlation module **306** may also be configured to correlate portions of the datasets with each other. Data correlation is an intelligent way of associating a portion of the datasets with another portion of the datasets. The data correlation may be based on time synchronization, shared social relation (e.g., devices are owned by user accounts in the same social group), shared data dimension (e.g., both devices measures weight), shared data source profile (e.g., location or device-type, etc.), data owner profile (e.g., user profile or user configurations), shared known semantic (e.g., both devices are considered “kitchenware”), shared known context (e.g., both devices are operated in the context of exercising), or any combination thereof.

For example, the data reported from a networked heating system may be correlated with the data reported from a networked thermometer based on a shared data dimension and a shared data source location. As another example, aggregated data reported from an exercise tracker on a first user may be correlated with an aggregated dataset of heart rate data of the first user (i.e., because of shared known context of “user health”). The aggregated dataset of heart rate data may in turn then be correlated with an aggregated dataset of user reported calorie count from the first user (i.e., because of shared known context of “user health”).

The data correlation module **306** is configured to interface with the data analysis module **308**. The data analysis module **308** is configured to determine a set of semantic or context data from the correlated datasets. Note that part of the correlated datasets may include semantic or contextual data already.

Semantic

The data analysis module **308** may determine semantic meaning to each of the IoT devices **324** and the data processed by the data correlation module **306**. Initially, the IoT devices **324** do not have any assigned meaning to an user. For example, the IoT devices **324** are devices like switches, routers, light bulbs, fridge, TV, car, etc. However, to users, the IoT devices **324** symbolize more than just a bulb. Users prefer to use devices based semantic meanings of the devices. For example, an “X-Box” switch, “my home” router, “kitchen” light, “bathroom” light, “my parents” fridge, and “kitchen” TV are all potential semantic labels that may assist a user when operating a set of IoT devices **324**. The semantic labels on the IoT devices **324** may also assist the data analysis module **308** to better understand the context of the user’s intentions. For example, a “front door” may be in a context with different default behaviors or interoperable rules than a “bedroom door.” Similarly, data generated through these semantically labeled IoT devices **324** may also be semantically labeled. The data analysis module **308** may implement semantic learning to each user’s devices based at least one or more of the following methods:

User-based: Semantic meaning may be defined by a user. A user may submit through the client application interface **322** or the integration application **328** that a specific device is connected to another device. For example, the user may submit through the client interface that a switch is connected to a game console X-Box, and hence the switch may be labeled the “X-box switch.”

Device-based: Semantic meaning may be determined via an adaptive correlation mechanism as implemented through the data correlation module **306** described above. Through network scanning techniques, the adaptive correlation mechanism may identify that the user’s smartphone sees the specific light bulb always at the same time when a fridge is also identified. The adaptive correlation mechanism may learn that the light bulb has significant meaning together

with the fridge. Such a correlation of data enables an understanding that the light bulb is very close to the fridge. The data analysis module **306** can then adopt an existing semantic meaning of the fridge being in the “kitchen” to the specific light bulb (i.e., labeling the light bulb as the “kitchen” light bulb).

Behavior profile based: The data analysis module **308** may profile user’s behavioral patterns and identify places, devices and people that a user is connected to during his/her day. For example, when a user is connected to IoT devices always or highly frequently during working days from a specific router or a geo-location, then the data analysis module **308** may label the IoT devices with a semantic meaning of being a “work” device based on association the specific router or with a geolocation of work.

Context Awareness

Through semantic awareness and devices’ interoperability, the data analysis module **308** may recognize the context between and/or amongst devices, people, places and time. Context may be organized semantically for ease of comprehension by the user of the integration platform. Context may work to approximate or describe a real-life situation, place, event, or people based on datasets collected from the IoT devices or other nodes (e.g., social network, external user-associated accounts, or geographical databases). Context may work to predict a future situation based on datasets collected from the IoT devices. Context may answer questions, such as who is doing what activity at when and where, and why is the activity being done. For example, the context of “mother is cooking dinner in the kitchen tonight” may be detected by activation of mother’s cellphone near a networked oven that is also activated. Context awareness mechanisms of the data analysis module **308** may be derived through one or more of the following methods:

Behavior profile based: The data analysis module **308** may derive at a particular context through device behavior analysis. For example, “finished running”, “child arrives home from school” awareness are recognized based on devices behaviors including when exercise tracker stopped registering movement or when a smart TV is tuned to a cartoon channel at home in the afternoon.

Socially-based: The data analysis module **308** may derive at a particular context through interaction with social graph data from a social network associated with a user account. For example, when users communicate to their friends via a social network, a matching mechanism can be applied to assign awareness of a friendship relationship to the devices of the user’s friends. A semantic label of a “friend Erica’s smart watch” may be assigned to a wearable device registered to a friend of the user named “Erica”. Henceforth, any activity observed through the smart watch may have a social context to the user as an activity performed by the friend “Erica”. As another example, when a device registered to “Erica” (e.g., the device is frequently or always with “Erica”) is detected in the vicinity of the user’s active region (e.g., where the data analysis module **308** has determined the user to be or location of a networked door of a registered home to the user), the data analysis module **308** may register a contextual event of “Erica is at the door.”

Geo-location based: The data analysis module **308** may further identify geo-locations of multiple devices’ activities to determine location context. In each network scanning event of a connected IoT device, a geolocation (longitude, latitude, accuracy) may be collected. Therefore, each IoT device and/or IoT device activity can have a geolocation history that defines the device’s geolocation context. Geo-location, for example, may be reported via a global posi-

tioning system (GPS) component or a network module (e.g., via network source triangulation) of the IoT devices 324.

The data analysis module 308 may also determine the geo-location of an IoT device by generating and maintaining an in-door navigation map. Techniques, such as GPS geo-
5 location and/or cellular network-based geo-location navigation systems, may not be as effective or readily available (e.g., due to low signal strength) while in-doors for positioning people and devices. In one embodiment, an in-door geo-location solution may include special hardware systems that are placed inside the building for indoor geo-location and navigation.

A preferred solution may include geo-location via local network connections without additional special hardware systems. In various embodiments, a directory of connected
15 devices that belong to the user may be kept in a database store coupled to the data analysis module 308. The directory along with beacon signal from Bluetooth or WiFi may be used to estimate the position of a user indoors. For example, for each Wi-Fi network router scanning, the GPS geolocation and RSSI may both be collected through the data correlation module 306 or the data analysis module 308. The RSSI enables the data analysis module 308 to position local networking devices (e.g., routers, access points, or switches)
20 relatively to each other in every specific geo-location point. Each IoT devices connected to the indoor network (e.g., Wi-Fi) through its visibility position relative to the local networking devices in every moment may thus enable locating of the user and IoT device activities in-house.

The data analysis module 308 may calculate the set of context in real-time as data is reported from the IoT devices. Absolute and/or relative timing of IoT device data may be used for temporal context. For example, the data correlation module 306 may correlate IoT device activation times from IoT devices in the same room. The data analysis module 308
25 can then compute a user relevant context from the device activation times. For example, if the IoT device activation times are close to one another within a predetermined time period in the morning, the data analysis module 308 may record a “user has woken up” context. As another example, if IoT device disconnection times for IoT devices within the same room are simultaneous within a very close margin, the data analysis module 308 may record a “blackout” context. This “blackout” context may be differentiated from when the IoT device disconnection times are sequential instead of simultaneous. As yet another example, a sequential turning off of IoT devices may signal a “user getting ready to sleep” context or “user leaving home” context.

Correlative Insights

Correlative insights may also be determined by the data analysis module 308. The correlative insights are actionable insights for facilitating the user to make decisions regarding what action(s) to take. FIGS. 10A-10B illustrate examples of how the correlative insights may be shown on a consolidated interface generated by the consolidation interface generator module 304. For example, the data correlation module 306 may be able to collect a first data set of glucose level data from a wearable device of a user. The data correlation module 306 may also be able to collect a second data set of activity level data from another wearable device of the user.
30 The data correlation module 306 may then correlate the two datasets. The data analysis module 308 may determine a correlative insight that “high activity level leads to sudden drop in glucose level.” This correlative insight may then be used to generate interoperable rules to notify the user to stop exercising after a certain activity level is reached in order to avoid sudden drops in glucose level.

The consolidation interface generator 304 is configured to provide a consolidation interface to access and/or manage IoT devices connected to the integration platform 300. The consolidation interface generator 304 enables consolidation of connected devices for a consumer/user to a single client interface. The single client interface may be presented on the integration application 328 or any other network device capable of accessing the web and connect with the integration backend system 302. The consolidation interface generator 304 may also be configured to provide access to real-time or non-real-time data captured by one or more of the IoT devices.

As a specific example, the data correlation module 306 may aggregate data to generate a “life line” to be presented through the client interface generated by the consolidation interface. The “life-line” may serve as an automated diary related to a user as illustrated in FIG. 4. A users’ daily activities and events may all or partially be correlated together in the order of the time of the day.

The “life line” may include context events determined by the data analysis module 308 as well as data from the IoT devices. The “life line” may be accessible to the user and/or social connections (e.g., friends in a social network) of the user through the consolidation interface. The “life line” may provide a big picture view for the user to visualize relevant correlated datasets related to him/herself. The “life line” may tag IoT device data in a timeline automatically based on a context-relevancy determination by the data analysis module 308 or based on user interaction. The “life line” may also be a motivator for collection of semantic data from a user.
35 For example, when a user spent a considerable large amount of time in a place, the data correlation module 306 can collect and correlate data associated with a default name “place in Menlo park.” The user may then be motivated to correct the semantic label to “home.”

For example, users may be able to see a life log with places the user has been, activity tracking data, health statuses, calendar events, weather data—all data correlated together over the timeline of the day. Additionally, the user may be able to add his/her custom events on the “life line”. The “life-line” is thus user specific. The accessibility and/or configurability of the “life-line” may be secured via privacy settings per user. Data (e.g., measurements, commands, status updates, and etc.) coming from the IoT devices 324 may be aggregated, analyzed, and/or correlated via the data correlation module 306 and/or the data analysis module 308. An advantage of the data analysis and data correlation is generation of one or more layers of contextual, correlative, and/or semantic insights, trigger events, and/or actions. The data analysis module 308 may apply machine learning on the analyzed and/or correlated data coming from the three layers described above and create a sense of “cognition”—understanding of contextual, correlative, and/or semantic events in a user’s life. These layers enable predictive or reflective comprehension of user and/or IoT device behavior patterns and/or trends, and may further enable synthesis of generalizations of user and/or IoT device activity or need.

Detection of contextual events may be useful as evident below for the purposes of generating and executing interoperable IoT device rules, such as for the use by the rule generation module 310, the rule execution module 314, and the event track module 316. For example, when the friend’s (e.g., Erica’s) activity tracker is close to the connected door lock of the user, and the user has given permissions, then the connected door lock can open automatically by recognition of a social context of a “friend at my home next to my connected door.”

Interoperability—Rule Generation and Execution

It has been discovered that interoperability is a significant part of consolidation of vertical solutions for IoT devices. Interoperability functions may be implemented through the rule generation module, the device identification module **312**, the rule execution module **314**, and/or the event track module **316**. Interoperability enables creation of logical connections between the connected IoT devices. For example, when a user turns off his office lights and leaves the work, then his home temperature may be set automatically for a desired temperature. The logical connections between the connected IoT devices may be created through users' natural languages. For example, a logical IoT devices rule may be implemented through a natural language indication by "when I leave home, turn off my lights and start my Roomba vacuum cleaner" or "when I finish exercising, then cool down my car".

Once a logical connection is defined, the logical connection can take place based on defined interoperable rules without any user interference. The interoperability functions may be based on a trigger-action mechanism responsible for creating (e.g., the rule generation module **310**), storing (e.g., the rule generation module **310**), validating (e.g., the rule generation module **310**), tracking (e.g., event tracking module **316**), and activating (e.g., the rule execution module **314**) the interoperable rules. For example, the rule generation **310** may create, store, and confirm a context event based rule with the user. The event track monitor **316** may, for example in substantially real-time or periodically, recognize context triggered conditions (e.g., "I left home"; "finished exercising", or "Erica entered to the kitchen"). The rule execution module **314** may then execute the context event based rule when the context triggered condition is satisfied.

As an example, the rule generation module **310** may have created a context-based rule of "if user left the house then turn off all in-house devices." The event track module **316** through the data analysis module **308** may be able to detect in real-time that a "user has left the house" context at time point T_1 . Thus in response to the detection of the conditional event at time T_1 , the rule execution module **314** may execute multiple shutdown commands to multiple IoT devices at the user's home address.

As another example, an interoperable rule may be an authentication condition coupled to unlocking of a connected security device (e.g., a network enabled door). The authentication condition, for example, may be a contextual event of "a friend coming over to my house." The event track module **316** may detect this contextual event when a friend's activity tracker device nears the connected door of the user. In this example, the geo-location of the connected activity tracker or other wearable devices of the friend can be used as the basis of confirming the authentication condition. The authentication condition may include multiple other factors, including geo-location proximity of a second and/or a third device belonging to the user or the user's friend, including smartphones or mobile devices. The rule generation module **310** is configured to facilitate creation of rules to control the IoT devices. The rule generation module **310** may couple to a rule management interface. The rule management interface may be part of the consolidation interface generated by the consolidation interface generation module **304**. The rule management interface may be part of the consolidation interface generated by the consolidation interface generator **304**. Rules may be configured by a user or automatically determined by the rule generation module **310**. When a rule is determined by the rule generation module **310**, the rule is shown as a recommendation. The

recommendation is then suggested through the consolidation interface for validation by the user. The rules may be stored on the integration backend system **302** or on an IoT device associated with a user who created or validated the rule.

The rules may include conditionals based on events, context, user trigger, time trigger, or any combination thereof. The rule generation module **310** may be coupled a rule management interface that enables selection(s) of a conditional followed by selection(s) of a command. A rule recommendation may be determined by an adaptive learning mechanism, such as by user behavior pattern (e.g., every morning the user turns on the air conditioning to 70 degrees), by user-profiling (e.g., other users of the same age and/or gender prefer to have a health report aggregated from health-related IoT devices and therefore a rule to generate a health report is created), or by social triggers (e.g., a friend who owns a Tesla decides to send over his IoT device rules associated with owning a Tesla).

A user is able to define the interoperability between his IoT devices according to his will, preference, habits, and/or desire of automation or any other type of motivation. Based on users' behaviors and users' profiling, the adaptive learning mechanism may recognize user's behavioral routine patterns and offer to a user to add an interoperable logical connection (i.e., IoT interoperable rule) between his/her connected devices. For example, the data correlation module **306** and the data analysis module **308** can recognize that every morning a user starts the coffee machine, turns on the music, leaves a house, and turns off all lights and thermostat. This sequence of IoT device commands to the coffee machine and the music player may be a recommended rule triggered by a context event of the user waking. The IoT device commands to the thermostat and the lights may be triggered by the context event of the user leaving the house. Users may also recommend the interoperable logical rules to their friends through any communication channel, e.g., social networks, emails, cellular messages, instant messages, or any combination thereof.

The event track module **316** is configured to synchronize execution of rules based on events. When the interoperable IoT rules are generated, execution of the rules may be based on a variety of conditional events. For example, the conditional events may include context-based events, device-state-based events, absolute or relative time-based events, socially triggered events, user profile triggered events, user behavior/interaction triggered events, or any sequential or parallel combination thereof. The event track module **316** may interface with the data analysis module **308** to detect the context-based events and execute context-based rules generated by the rule generation module **310**. The event track module **316** may detect conditional events in the connected IoT devices **324** based on polling the connected IoT devices **324**, or based on interrupts received from the IoT devices **324**, the solution specific application **322**, and/or the integration application **328**.

In various embodiments, the event monitoring mechanism of the event track module **316** may be implemented on the integration application **328**, the integration backend system **302**, the IoT devices **324**, or a combination thereof. When some logic of the event track module **316** is implemented on the IoT devices **324** or the integration application **328**, the event track module **316** may be able to detect condition events based on interrupts instead of polling.

The implementation of the interoperable rule validation, tracking and execution may be distributed. For example, the implementation of the interoperable rules may be based on a distributed mesh model in communication with a central

cloud service system (e.g., the integration backend system **302**). In various embodiments, every user running the integration application **328** can validate, track, and execute interoperable rules, even if the interoperable rules do not belong to the user. For example, if a user lost a Bluetooth tagged keychain, the integration platform **300** may try to scan proximal environments of other users' devices for the user's keychain. Identifiers from the other users' devices may remain anonymous and/or encrypted for privacy reasons. The final location of the keychain is also shielded from access by the other users even if the other users' devices contributed to the locating of the keychain. An anonymized identifier may then be transferred to the integration backend server **302** to inform the user that the key chain is found.

The rule execution module **314** is configured to execute an interoperability logical rule through the IoT devices **324**, the integration backend system **302**, the integration application **328**, the solution-specific applications **322**, the device-specific backend systems **320**, or any combination thereof. The rule execution module **314** may be configured to communicate with the above systems through the communication interface **318** to enable communication between all of the above devices, applications, and systems. The rule execution module **314** may also synchronize execution of commands related to multiple IoT devices. In various embodiments, similar to tracking of the trigger conditions, the execution of commands may also be distributed, including via devices owned by a user who is not the owner of the interoperable rule. In various embodiments, each user who owns devices may enable permission settings that allow other users to use the owned devices for tracking or execution of interoperable rules.

Blocks, components, and/or modules associated with the IoT integration platform system **300** may be implemented as hardware modules, software modules, or any combination thereof. For example, the modules described can be software modules implemented as instructions on a tangible storage memory capable of being executed by a processor or a controller on a machine. The tangible storage memory may be a volatile or a non-volatile memory. In some embodiments, the volatile memory may be considered "non-transitory" in the sense that it is not a transitory signal. Software modules may be operable when executed by a processor or other computing device, e.g., a single board chip, a field programmable field array, a network capable computing device, a virtual machine terminal device, a cloud-based computing terminal device, or any combination thereof.

Each of the modules may operate individually and independently of other modules. Some or all of the modules may be executed on the same host device or on separate devices. The separate devices can be coupled via a communication module to coordinate its operations. Some or all of the modules may be combined as one module.

A single module may also be divided into sub-modules, each sub-module performing separate method step or method steps of the single module. In some embodiments, the modules can share access to a memory space. One module may access data accessed by or transformed by another module. The modules may be considered "coupled" to one another if they share a physical connection or a virtual connection, directly or indirectly, allowing data accessed or modified from one module to be accessed in another module. In some embodiments, some or all of the modules can be upgraded or modified remotely. The IoT integration platform system **300** may include additional, fewer, or different modules for various applications.

FIG. 4 is an example of an user interface illustrating an active lifeline diagram **400** for a user account on an integration interface, such as the integration interface **114** of FIG. 1 or the integration application **328** of FIG. 3, consistent with various embodiments of the disclosed technology. For purposes of illustration, the single life line diagram **400** is divided into three columns to fit on a page. However, it will be understood that the columns are intended to be sequentially connected to one another from left to right. The active lifeline diagram **400**, for example, may be part of the consolidation interface generated by the consolidation interface generator **304** of FIG. 3. The active lifeline diagram **400** may be accessible through the integration application **328**.

As shown, the active lifeline diagram **400** illustrates a single day of a user, organized by when the user woke up to when the user went to sleep. Although the active lifeline diagram **400** has been illustrated for a time period of a single day, the user may define the length of the history data to any time period. In various embodiments, the user may scroll back between consecutive time periods along the life diagram **400**. The active lifeline diagram **400** includes illustrations of semantic labels **402**, contextual events/activities **404**, icons of relevant IoT devices **406**, relevant IoT device data **408**, correlated contextual data **410**, and externally sourced data **412**, such as data source from a social network status report.

As a specific example, the correlated contextual data **410** may represent a user interface element on the top of the lifeline diagram **400** that enables tagging of activities or postings specific to fitness activity contextual labels (e.g., sleep, idle, active, and exercise). As another example, the icon of the relevant IoT device **406** is illustrated along with a contextual event that a new device and a new semantic label has been added for "My XBOX."

The active lifeline diagram **400** may respond and visualize correlative insights according to periodic or real-time data, or context updates, enabling users of the active lifeline diagram **400** to take action based on the insights. The active lifeline diagram **400** may also enable a user to tag or post his/her own updates as part of a life-logging mechanism. An example of a semantic camera interface to facilitate the life logging is illustrated in FIGS. 11A-11D. For example, the active lifeline diagram **400** may be advantageous in achieving a health action plan with live feedback information. This is a significant step-up from a mere lifestyle blog. The active lifeline diagram **400** may not only consolidate lifestyle and daily routine data (e.g., exercise and performance data) relating to fitness activities, but may also correlate a user's lifestyle habits and daily routine with a context of how healthy the user is based on numerous measurements and reports.

Elements of the lifeline diagram **400** may be divided into at least the following categories: life logging posts **414**, type A elements **416**, type B elements **418**, type C elements **420**, type D elements **422**, type E elements **424**, or any combination thereof. A life log post **414** is a user reported post or tag on the lifeline diagram **400**. For example, the life logging posts may follow the following rules. A "+" sign may appear at the top of the lifeline when there is no other activity, on idle time, or when there is no other notification, element, or correlation within the same time period. When the plus sign is tapped, the posting options may appear. When choosing the post option, the plus sign may change to a camera icon enabling the semantic camera interface described in FIGS. 11A-11D. An editable text may appear on the left of the plus sign, such as "what is on your mind?" to request the user to specify an activity or a topic, or "what is this place?" to

request the user to specify a location. If the user is idle and does not edit or take a photo for more than a threshold number of seconds, such as three seconds, then the post becomes a C type element **420**, and the plus sign re-appears.

A type A element **416** is an activity or event where the place and description text is predefined by the integration platform **300**. However, a user may edit the text of the type A element **416** (e.g., by tapping once). The edited text may be returned to the integration platform **300**, such as the integration backend system **302** for future rendering of the life line diagram **400**. A type B element **418** is a node on the life line diagram **400**. The node image may be defined by the integration platform **300**, where the images may be cached off-line. The description text may be predefined by the server and editable by the user similar to the type A element **416**. Again, the edited text may be returned to the integration platform **300**.

A type C element **420** is a node on the lifeline diagram **400**, where the node is represented by an iconic image. The default iconic image may be received from the integration backend system **302**. However, the user may tap the iconic image to take and upload a picture to the integration backend system **302**. A type D element **422** is a node on the lifeline diagram **400**, where the node is associated with an activity, a contextual icon, and a display of data. A type E element **424** is a node on the lifeline diagram **400**, where the node is a data representation diagram. The user may configure how the data come from the integration backend system **302**. The user may also configure how the data is represented in the data representation diagram.

Referring now to FIG. **5**, therein is shown a diagrammatic representation of a machine in the example form of a computer system **500** within which a set of instructions, for causing the machine to perform any one or more of the methodologies or modules discussed herein, may be executed.

In the example of FIG. **5**, the computer system **500** includes a processor, memory, non-volatile memory, and an interface device. Various common components (e.g., cache memory) are omitted for illustrative simplicity. The computer system **500** is intended to illustrate a hardware device on which any of the modules or components depicted in the example of FIG. **2** or FIG. **3** (and any other components described in this specification) can be implemented. The computer system **500** can be of any applicable known or convenient type. The components of the computer system **500** can be coupled together via a bus or through some other known or convenient device.

This disclosure contemplates the computer system **500** taking any suitable physical form. As example and not by way of limitation, computer system **500** may be an embedded computer system, a system-on-chip (SOC), a single-board computer system (SBC) (such as, for example, a computer-on-module (COM) or system-on-module (SOM)), a desktop computer system, a laptop or notebook computer system, an interactive kiosk, a mainframe, a mesh of computer systems, a mobile telephone, a personal digital assistant (PDA), a server, or a combination of two or more of these. Where appropriate, computer system **500** may include one or more computer systems **500**; be unitary or distributed; span multiple locations; span multiple machines; or reside in a cloud, which may include one or more cloud components in one or more networks. Where appropriate, one or more computer systems **500** may perform without substantial spatial or temporal limitation one or more steps of one or more methods described or illustrated herein. As an example and not by way of limitation, one or more

computer systems **500** may perform in real time or in batch mode one or more steps of one or more methods described or illustrated herein. One or more computer systems **500** may perform at different times or at different locations one or more steps of one or more methods described or illustrated herein, where appropriate.

The processor may be, for example, a conventional microprocessor such as an Intel Pentium microprocessor or Motorola power PC microprocessor. One of skill in the relevant art will recognize that the terms “machine-readable (storage) medium” or “computer-readable (storage) medium” include any type of device that is accessible by the processor.

The memory is coupled to the processor by, for example, a bus. The memory can include, by way of example but not limitation, random access memory (RAM), such as dynamic RAM (DRAM) and static RAM (SRAM). The memory can be local, remote, or distributed.

The bus also couples the processor to the non-volatile memory and drive unit. The non-volatile memory is often a magnetic floppy or hard disk, a magnetic-optical disk, an optical disk, a read-only memory (ROM), such as a CD-ROM, EPROM, or EEPROM, a magnetic or optical card, or another form of storage for large amounts of data. Some of this data is often written, by a direct memory access process, into memory during execution of software in the computer system **500**. The non-volatile storage can be local, remote, or distributed. The non-volatile memory is optional because systems can be created with all applicable data available in memory. A typical computer system will usually include at least a processor, memory, and a device (e.g., a bus) coupling the memory to the processor.

Software is typically stored in the non-volatile memory and/or the drive unit. Indeed, for large programs, it may not even be possible to store the entire program in the memory. Nevertheless, it should be understood that for software to run, if necessary, it is moved to a computer readable location appropriate for processing, and for illustrative purposes, that location is referred to as the memory in this paper. Even when software is moved to the memory for execution, the processor will typically make use of hardware registers to store values associated with the software, and local cache that, ideally, serves to speed up execution. As used herein, a software program is assumed to be stored at any known or convenient location (from non-volatile storage to hardware registers) when the software program is referred to as “implemented in a computer-readable medium.” A processor is considered to be “configured to execute a program” when at least one value associated with the program is stored in a register readable by the processor.

The bus also couples the processor to the network interface device. The interface can include one or more of a modem or network interface. It will be appreciated that a modem or network interface can be considered to be part of the computer system **500**. The interface can include an analog modem, isdn modem, cable modem, token ring interface, satellite transmission interface (e.g., “direct PC”), or other interfaces for coupling a computer system to other computer systems. The interface can include one or more input and/or output devices. The I/O devices can include, by way of example but not limitation, a keyboard, a mouse or other pointing device, disk drives, printers, a scanner, and other input and/or output devices, including a display device. The display device can include, by way of example but not limitation, a cathode ray tube (CRT), liquid crystal display (LCD), or some other applicable known or convenient display device. For simplicity, it is assumed that

controllers of any devices not depicted in the example of FIG. 5 reside in the interface.

In operation, the computer system 500 can be controlled by operating system software that includes a file management system, such as a disk operating system. One example of operating system software with associated file management system software is the family of operating systems known as Windows® from Microsoft Corporation of Redmond, Wash., and their associated file management systems. Another example of operating system software with its associated file management system software is the Linux operating system and its associated file management system. The file management system is typically stored in the non-volatile memory and/or drive unit and causes the processor to execute the various acts required by the operating system to input and output data and to store data in the memory, including storing files on the non-volatile memory and/or drive unit.

Some portions of the detailed description may be presented in terms of algorithms and symbolic representations of operations on data bits within a computer memory. These algorithmic descriptions and representations are the means used by those skilled in the data processing arts to most effectively convey the substance of their work to others skilled in the art. An algorithm is here, and generally, conceived to be a self-consistent sequence of operations leading to a desired result. The operations are those requiring physical manipulations of physical quantities. Usually, though not necessarily, these quantities take the form of electrical or magnetic signals capable of being stored, transferred, combined, compared, and otherwise manipulated. It has proven convenient at times, principally for reasons of common usage, to refer to these signals as bits, values, elements, symbols, characters, terms, numbers, or the like.

It should be borne in mind, however, that all of these and similar terms are to be associated with the appropriate physical quantities and are merely convenient labels applied to these quantities. Unless specifically stated otherwise as apparent from the following discussion, it is appreciated that throughout the description, discussions utilizing terms such as “processing” or “computing” or “calculating” or “determining” or “displaying” or “generating” or the like, refer to the action and processes of a computer system, or similar electronic computing device, that manipulates and transforms data represented as physical (electronic) quantities within the computer system’s registers and memories into other data similarly represented as physical quantities within the computer system memories or registers or other such information storage, transmission or display devices.

The algorithms and displays presented herein are not inherently related to any particular computer or other apparatus. Various general purpose systems may be used with programs in accordance with the teachings herein, or it may prove convenient to construct more specialized apparatus to perform the methods of some embodiments. The required structure for a variety of these systems will appear from the description below. In addition, the techniques are not described with reference to any particular programming language, and various embodiments may thus be implemented using a variety of programming languages.

In alternative embodiments, the machine operates as a standalone device or may be connected (e.g., networked) to other machines. In a networked deployment, the machine may operate in the capacity of a server or a client machine in a client-server network environment, or as a peer machine in a peer-to-peer (or distributed) network environment.

The machine may be a server computer, a client computer, a personal computer (PC), a tablet PC, a laptop computer, a set-top box (STB), a personal digital assistant (PDA), a cellular telephone, an iPhone, a Blackberry, a processor, a telephone, a web appliance, a network router, switch or bridge, or any machine capable of executing a set of instructions (sequential or otherwise) that specify actions to be taken by that machine.

While the machine-readable medium or machine-readable storage medium is shown in an exemplary embodiment to be a single medium, the term “machine-readable medium” and “machine-readable storage medium” should be taken to include a single medium or multiple media (e.g., a centralized or distributed database, and/or associated caches and servers) that store the one or more sets of instructions. The term “machine-readable medium” and “machine-readable storage medium” shall also be taken to include any medium that is capable of storing, encoding or carrying a set of instructions for execution by the machine and that cause the machine to perform any one or more of the methodologies or modules of the presently disclosed technique and innovation.

In general, the routines executed to implement the embodiments of the disclosure, may be implemented as part of an operating system or a specific application, component, program, object, module or sequence of instructions referred to as “computer programs.” The computer programs typically comprise one or more instructions set at various times in various memory and storage devices in a computer, and that, when read and executed by one or more processing units or processors in a computer, cause the computer to perform operations to execute elements involving the various aspects of the disclosure.

Moreover, while embodiments have been described in the context of fully functioning computers and computer systems, those skilled in the art will appreciate that the various embodiments are capable of being distributed as a program product in a variety of forms, and that the disclosure applies equally regardless of the particular type of machine or computer-readable media used to actually effect the distribution.

Further examples of machine-readable storage media, machine-readable media, or computer-readable (storage) media include but are not limited to recordable type media such as volatile and non-volatile memory devices, floppy and other removable disks, hard disk drives, optical disks (e.g., Compact Disk Read-Only Memory (CD ROMS), Digital Versatile Disks, (DVDs), etc.), among others, and transmission type media such as digital and analog communication links.

In some circumstances, operation of a memory device, such as a change in state from a binary one to a binary zero or vice-versa, for example, may comprise a transformation, such as a physical transformation. With particular types of memory devices, such a physical transformation may comprise a physical transformation of an article to a different state or thing. For example, but without limitation, for some types of memory devices, a change in state may involve an accumulation and storage of charge or a release of stored charge. Likewise, in other memory devices, a change of state may comprise a physical change or transformation in magnetic orientation or a physical change or transformation in molecular structure, such as from crystalline to amorphous or vice versa. The foregoing is not intended to be an exhaustive list of all examples in which a change in state for a binary one to a binary zero or vice-versa in a memory

device may comprise a transformation, such as a physical transformation. Rather, the foregoing are intended as illustrative examples.

A storage medium typically may be non-transitory or comprise a non-transitory device. In this context, a non-transitory storage medium may include a device that is tangible, meaning that the device has a concrete physical form, although the device may change its physical state. Thus, for example, non-transitory refers to a device remaining tangible despite this change in state.

FIG. 6 shows an embodiment of a wireless device 600 which includes the capability for wireless communication. The wireless device 600 may be included in any one of the devices shown in FIG. 2, although alternative embodiments of those devices may include more or fewer components than the wireless device 600.

Wireless device 600 may include an antenna system 401. Wireless device 600 may also include a digital and/or analog radio frequency (RF) transceiver 602, coupled to the antenna system 601, to transmit and/or receive voice, digital data and/or media signals through antenna system 601.

Wireless device 600 may also include a digital processing system 603 to control the digital RF transceiver and to manage the voice, digital data and/or media signals. Digital processing system 603 may be a general purpose processing device, such as a microprocessor or controller for example. Digital processing system 603 may also be a special purpose processing device, such as an ASIC (application specific integrated circuit), FPGA (field-programmable gate array) or DSP (digital signal processor). Digital processing system 603 may also include other devices, as are known in the art, to interface with other components of wireless device 600. For example, digital processing system 603 may include analog-to-digital and digital-to-analog converters to interface with other components of wireless device 600. Digital processing system 603 may include a media processing system 609, which may also include a general purpose or special purpose processing device to manage media, such as files of audio data.

Wireless device 600 may also include a storage device 604, coupled to the digital processing system, to store data and/or operating programs for the wireless device 600. Storage device 604 may be, for example, any type of solid-state or magnetic memory device.

Wireless device 600 may also include one or more input devices 605, coupled to the digital processing system 603, to accept user inputs (e.g., telephone numbers, names, addresses, media selections, etc.) Input device 605 may be, for example, one or more of a keypad, a touchpad, a touch screen, a pointing device in combination with a display device or similar input device.

Wireless device 600 may also include at least one display device 606, coupled to the digital processing system 603, to display information such as messages, telephone call information, contact information, pictures, movies and/or titles or other indicators of media being selected via the input device 605. Display device 606 may be, for example, an LCD display device. In one embodiment, display device 606 and input device 605 may be integrated together in the same device (e.g., a touch screen LCD such as a multi-touch input panel which is integrated with a display device, such as an LCD display device). The display device 606 may include a backlight 606A to illuminate the display device 606 under certain circumstances. It will be appreciated that the Wireless device 600 may include multiple displays.

Wireless device 600 may also include a battery 607 to supply operating power to components of the system includ-

ing digital RF transceiver 602, digital processing system 603, storage device 604, input device 605, microphone 605A, audio transducer 608, media processing system 609, sensor(s) 610, and display device 606. Battery 607 may be, for example, a rechargeable or non-rechargeable lithium or nickel metal hydride battery. Wireless device 600 may also include audio transducers 608, which may include one or more speakers, and at least one microphone 605A. In certain embodiments of the present disclosure, the wireless device 600 can be used to implement at least some of the methods discussed in the present disclosure.

FIG. 7 is a flow diagram of a method 700 of data consolidation, consistent with various embodiments of the disclosed technology. The method 700 includes extracting a first data record (e.g., a data entry, measurement, stream, etc.) from a data source connected to an IoT integration platform, such as the IoT integration platform 200 of FIG. 2 or the integration platform 300 of FIG. 3, at a step 702. The data source may be an external data source, data reported from one or more IoT devices, or analyzed and/or correlated data based on the above, such as contextual data, correlations, semantic data, or other metadata. The step 702 may include determining a unique identifier of a first IoT device, where the first IoT device is the data source. The step 702 may be performed by the data correlation module 306 of FIG. 3.

Optionally data records may be normalized. For example, the first data record may be normalized with respect to other data record along a same data dimension at step 704. The step 704 may be performed by the data correlation module 306 as well.

Part of the data consolidation also includes correlating the data records and analyzing the data records to determine semantic label, context, and/or relevancy. For example, the data correlation module 306 may correlate the first data record with a second data record into a data set at a step 708. The data correlation may be based on a shared data dimension, a shared data context, a shared data source, a shared relevancy topic, a shared data semantic label, or any combination thereof. Optionally, the step 704 and the step 706 may be skipped prior to the data correlation.

The data analysis module 708 may analyze the first data record to generate a derivative record relevant to a user context at a step 708. The data analysis at the step 708 may be performed on the correlated data records in the data set generated at the step 706. Alternatively, the data analysis may also be performed directly on the extracted first data record and/or the normalized first data record of the steps 702 and 704, respectively.

The derivative record may include determination of a context of an IoT device activity. The derivative record may include determination of a semantic label for an IoT device associated with the first data record. The derivative record may include other predictive, trending, and/or comparative analytics. The derivative record may be used in another instance of the data consolidation flow as the extracted data record, such as in the step 702. The derivative record may be formatted as a natural language statement in any number of languages, such as the user's natural language.

After the above steps, different data records and data sets may be aggregated into a data cluster for a particular contextual relevant grouping, such as aggregating the first data record into a data cluster at step 710. The derivative record may also be aggregated into the data cluster. The data cluster may represent an aggregation of data that is beyond correlated. For example, a heart rate monitor data record may be correlated at the step 706 with a glucose level

monitor data record because of a shared semantic and context of health related data. However, these health related data may be aggregated into a data cluster for other non-health-related activities on the same day because the relevant grouping of the data cluster pertains to the activities of the day.

After the above steps of data processing, the derivative record and/or the first data record is presented (e.g., visualized or audibly presented) on an integration interface for the user at a step 712. The first data record and/or the derivative record may be presented on the integration interface along with other data sets or data records of the data cluster. The context indication may be determined based on the derivative record from the step 714. The visualization may also include comparative visualization, semantic visualization, or topical visualization (e.g., based on topical relevancy). The visualization may present the first data record within the aggregated data cluster. The visualization may present the first data record after the first data record is normalized. The visualization may present the first data record and the correlated second data record simultaneously together for illustrating the shared data category or the shared context, such as the context from the context indication.

FIG. 8 is a flow diagram of a method 800 of interoperable IoT rule management, consistent with various embodiments of the disclosed technology. The method 800 includes receiving a selection of a semantic label associated with an IoT device from a user at step 802. The step 802 may be implemented by the rule generation module 310 of FIG. 3 through correspondence with a rule management interface. The semantic label may be generated from the data analysis module 308 of FIG. 3. Several semantic labels may be presented on the rule management interface, such as via the integration application 328 of FIG. 3 or the rule management interface illustrated in FIGS. 9A-9C. In various embodiments, the semantic label may be associated with more than one IoT devices.

The rule generation module 310 may determine a recommendation of an interoperable rule based on the semantic label in a step 804. Each interoperable rule may include a contextual condition trigger and an action policy to be executed when the contextual condition trigger is detected. The recommendation of the interoperable rule may be determined based on the selected semantic label, available context, and/or data dimensions from the IoT device associated with the semantic label. The interoperable rule recommendation may be determined based on a history of user behavior in operating IoT devices. The interoperable rule recommendation may be based on a previously configured interoperable rule by the user. The interoperable rule recommendation may be determined based on previously configured interoperable rules by other users of a similar user profile (e.g., age, gender, hobby, profession, or other demographic profile) as the user. The interoperable rule recommendation may be determined based on socially recommended interoperable rules by another user who is associated with the user via a social connection.

In response to receiving the selection, rule generation module 310 may present the recommendation of the interoperable rule on the rule management interface in a step 806. At a step 808, the rule management interface may receive a confirmation from the user to activate the interoperable rule.

In response to activation of the interoperable rule, the event track module 216 may monitor to detect the condition trigger of the interoperable rule in a network of connected IoT devices in a step 810. The condition trigger may include a contextual determination, a data pattern, or a state of the

IoT device associated with the selected semantic label. When the condition trigger is detected, the rule execution module 314 may execute the action policy of the interoperable rule to control one or more of the connected IoT devices in a step 812. The one or more of the connected IoT devices to be controlled by the action policy may include the IoT device associated with the selected semantic label.

FIG. 9A is a screen shot of a rule management interface 900 of an integration platform at a rule activation stage, consistent with various embodiments of the disclosed technology. FIG. 9A illustrates a list of interoperable rules 902, each with a condition trigger 904 linked to an action policy 906. Each condition trigger 904 may be described with respect to the semantic label and context of the IoT device involved for the condition trigger 904. A monitor device icon 908 may represent the IoT device involved with the condition trigger 904. Similarly, each action policy 906 may be described with respect to the semantic label and context of the IoT device involved for the action policy 906. An action device icon 910 may represent the IoT device involved with the action policy 906.

FIG. 9B is a screen shot of the rule management interface 900 of the integration platform at a condition selection stage, consistent with various embodiments of the disclosed technology. FIG. 9B illustrates a circle of various condition triggers 904 around the monitor device icon 908 for a user to select. FIG. 9C is a screenshot of the rule management interface 900 of the integration platform at an action selection stage, consistent with various embodiments of the disclosed technology. FIG. 9C illustrates a circle of various action policies 906 around the action device icon 910 for the user to complete the interoperable rule 902.

FIG. 10A is an exemplary screen shot 1000 illustrating the consolidation interface showing a correlative insight, consistent with various embodiments of the disclosed technology. FIG. 10A illustrates a correlative insight 1002 determined based on analysis of correlated data regarding a user's activity and glucose level as shown in the correlated data diagram 1004. FIG. 10A further illustrates an interoperable rule 1006 that may be defined and/or configured by the user in response to viewing the correlative insight 1002.

FIG. 10B is an exemplary screen shot 1050 illustrating the consolidation interface generating the interoperable rule 1006 from the correlative insight, consistent with various embodiments of the disclosed technology. The interoperable rule 1006 of FIG. 10A may be further described and/or configured. For example, the screen shot 1050 illustrates a description of a recommended interoperable rule 1006 of alerting the user when there is high activity range reached.

FIG. 11A is an exemplary screen shot illustrating a semantic camera interface 1100 at a first stage, the semantic camera interface used in conjunction with a life line diagram, consistent with various embodiments of the disclosed technology. At the first stage, the user is requested to add a node to the life line diagram. A semantic camera icon 1102 is shown in the center of the semantic camera interface 1100 to take a picture of node in question for labeling and/or image recognition.

FIG. 11B is an exemplary screen shot illustrating the semantic camera interface 1100 at a second stage, the semantic camera interface used in conjunction with a life line diagram, consistent with various embodiments of the disclosed technology. At the second stage, the user is asked to semantically label a type of entity of the node added. The bottom of the screen shot shows the recognized entity 1104 associated with the node to be added as determined by the integration platform 300. The center of the screen shot

25

shows an entity type query **1106** that requests the user to label the type of the node added.

FIG. **11C** is an exemplary screen shot illustrating a semantic camera interface **1100** at a third stage, the semantic camera interface used in conjunction with a life line diagram, consistent with various embodiments of the disclosed technology. At the third stage, the user is asked to semantically label the node added. The center of the screen shot shows a semantic label query **1108** that requests the user to semantically label the node added.

FIG. **11D** is an exemplary screen shot illustrating a semantic camera interface **1100** at a fourth stage, the semantic camera interface used in conjunction with a life line diagram, consistent with various embodiments of the disclosed technology. At the fourth stage, the user is asked to associate the node added with one or more people. The center of the screen shot shows a social association query **1110** that requests the user to associate the node added with one or more people.

What is claimed can include:

1. A method of maintaining interoperability amongst Internet of Things (IoT) devices connected via an IoT integration platform, comprising:

receiving a user selection of a semantic label associated with an IoT device on a rule management interface, wherein the rule management interface is generated for a user account associated with multiple IoT devices, each IoT device capable of communicating with a server or a mobile application via a network connection and wherein the semantic label provides context of the IoT device relative to the user account;

generating, based on the semantic label of the IoT device, an interoperable rule that includes a condition trigger to be detected by at least a first IoT device and an action policy to be executed by at least a second IoT device at satisfaction of the condition trigger, wherein the IoT device associated with the semantic label is the first IoT device for detecting the condition trigger, the second IoT device for executing the action policy, or both;

presenting the interoperable rule, including a natural language description of the interoperable rule, to request a user via the rule management interface to confirm activation of the interoperable rule;

receiving a user interaction on the rule management interface, wherein the user interaction indicates the activation of the interoperable rule;

in response to the activation of the interoperable rule, monitoring data from at least a sensor of the first IoT device to determine an indication that the condition trigger is satisfied; and

executing the action policy on the second IoT device in response to receiving the indication that the condition trigger is satisfied.

2. The method of claim **1**, further comprising monitoring to detect the condition trigger among the IoT devices, including the first IoT device, connected to the IoT integration platform.

3. The method of claim **2**, further comprising when the condition trigger is detected, executing the action policy by controlling one or more of the IoT devices, including the second IoT device.

4. The method of claim **1**, wherein the condition trigger includes determining a contextual event based on data received from the IoT devices.

26

5. The method of claim **4**, wherein determining the contextual event includes determining a geo-locational proximity of an authenticating IoT device from the IoT device.

6. The method of claim **5**, wherein the action policy includes commanding the IoT device to unlock a security mechanism.

7. The method of claim **5**, wherein determining the contextual event further includes determining whether a first user account registered to the authenticating IoT device is associated with a second user account registered to the IoT device on a social network.

8. The method of claim **4**, wherein determining the contextual event includes determining a movement of the IoT device.

9. The method of claim **1**, wherein determining the recommendation of the interoperable rule is based on a history of user behavior of operating the IoT devices.

10. The method of claim **1**, wherein determining the recommendation of the interoperable rule is based on a user profile of the user.

11. The method of claim **1**, wherein the recommendation of the interoperable rule is received from a first user account to a second user account operating the rule management interface.

12. A method of maintaining interoperability amongst Internet of Things (IoT) devices connected via an IoT integration platform, comprising:

identifying an IoT device configured to communicate, via a network connection, with a server or a mobile application that communicates with the IoT integration platform, wherein a user account in the IoT integration platform is associated with the IoT device and one or more other IoT devices;

determining an interoperable rule having a condition trigger and an action policy, the condition trigger associated with a first set of one or more IoT devices configured to monitor sensor data to detect when the condition trigger is satisfied, the action policy associated with a second set of one or more IoT devices configured to execute the action policy, wherein the IoT device is part of the first set of IoT devices, the second set of IoT devices, or both;

activating the interoperable rule in response to receiving a user confirmation of the interoperable rule via a rule management interface;

monitoring data from one or more sensors of the first set of the IoT devices to detect an indication that the condition trigger is satisfied; and

after receiving the indication that the condition trigger is satisfied, executing the action policy by controlling one or more of the IoT devices to execute the action policy.

13. The method of claim **12**, wherein identifying the IoT device includes assigning a unique identifier to the IoT device based on a device communication element.

14. The method of claim **12**, wherein identifying the IoT device includes assigning a unique identifier to the IoT device based on a device behavior of the IoT device as observed by another IoT device connected to the IoT integration platform.

15. The method of claim **12**, wherein identifying the IoT device includes assigning a unique identifier to the IoT device based on a communication protocol data and a device data element.

16. The method of claim **12**, wherein monitoring to detect the condition trigger includes monitoring the IoT device via data observed through another IoT device.

27

17. The method of claim 12, wherein monitoring to detect the condition trigger includes monitoring via polling for a status from the IoT device.

18. The method of claim 12, wherein monitoring to detect the condition trigger includes determining whether a context event is satisfied by analyzing data received from the IoT devices.

19. The method of claim 12, wherein determining the interoperable rule includes receiving the condition trigger and the action policy from the user via a rule management interface.

20. A machine-implemented integration platform system for maintaining interoperability amongst Internet of Things (IoT) devices connected thereto, the integration platform system comprising:

- a rule management interface configured to receive a user selection of a semantic label associated with an IoT device, wherein the rule management interface is generated for a user account associated with multiple IoT devices, each IoT device capable of communicating with a server or a mobile application via a network connection and wherein the semantic label provides context of the IoT device relative to the user account;
- a rule generation module, coupled to the rule management interface, configured to determine an interoperable rule based on the semantic label, the interoperable rule having a condition trigger to be detected by at least a first IoT device and an action policy to be executed by at least a second IoT device at satisfaction of the

28

condition trigger, wherein the IoT device associated with the semantic label is the first IoT device for detecting the condition trigger, the second IoT device for executing the action policy, or both;

wherein the rule management interface is further configured to present the interoperable rule to a user and to receive a confirmation from the user through the rule management interface to activate the interoperable rule;

an event track module configured to detect the condition trigger among the IoT devices connected to the IoT integration platform by monitoring data from one or more sensors of the IoT devices; and

a rule execution module, coupled to the event track module to receive an indication that the condition trigger is detected, configured to execute the action policy by controlling one or more of the IoT devices when the condition trigger is detected by the event track module.

21. The machine-implemented integration platform system of claim 20, further comprising:

- a device identification module configured to identify an IoT device associated with the user account and establish communication between the IoT device and with a server of the integration platform system or a mobile application associated with the integration platform system.

* * * * *