



US009558917B2

(12) **United States Patent**
Finley et al.

(10) **Patent No.:** **US 9,558,917 B2**
(45) **Date of Patent:** **Jan. 31, 2017**

(54) **ADJUSTABLE NON-DISSIPATIVE VOLTAGE BOOSTING SNUBBER NETWORK FOR ACHIEVING LARGE BOOST VOLTAGES**

(58) **Field of Classification Search**
CPC H01J 37/3417; H01J 37/3438; H01J 37/3444;
H01J 37/3467; H05H 1/46
See application file for complete search history.

(71) Applicant: **Advanced Energy Industries, Inc.**,
Fort Collins, CO (US)

(56) **References Cited**

(72) Inventors: **Kenneth W. Finley**, Fort Collins, CO
(US); **Hendrik Walde**, Fort Collins, CO
(US)

U.S. PATENT DOCUMENTS

(73) Assignee: **Advanced Energy Industries, Inc.**,
Fort Collins, CO (US)

| | | | |
|--------------|----|--------|-----------------|
| 2005/0092596 | A1 | 5/2005 | Kouznetsov |
| 2006/0192774 | A1 | 8/2006 | Yasumura |
| 2007/0217093 | A1 | 9/2007 | Xue et al. |
| 2008/0203070 | A1 | 8/2008 | Ilic et al. |
| 2011/0011737 | A1 | 1/2011 | Wu et al. |
| 2011/0075445 | A1 | 3/2011 | Drummond et al. |

(*) Notice: Subject to any disclaimer, the term of this patent is extended or adjusted under 35 U.S.C. 154(b) by 0 days.

(Continued)

FOREIGN PATENT DOCUMENTS

(21) Appl. No.: **15/222,597**

EP 2316123 A1 5/2011

(22) Filed: **Jul. 28, 2016**

OTHER PUBLICATIONS

(65) **Prior Publication Data**
US 2016/0336148 A1 Nov. 17, 2016

King, Monica C., "Restriction Requirement re U.S. Appl. No. 14/184,968", Jul. 23, 2015, p. 5 Published in: US.

(Continued)

Related U.S. Application Data

(60) Continuation of application No. 14/945,331, filed on Nov. 18, 2015, which is a division of application No. 14/185,213, filed on Feb. 20, 2014, now Pat. No. 9,224,579, which is a continuation of application No. 13/867,907, filed on Apr. 22, 2013, now Pat. No. 9,129,776, which is a continuation-in-part of application No. 13/666,668, filed on Nov. 1, 2012, now Pat. No. 9,226,380.

Primary Examiner — Monica C King

(74) *Attorney, Agent, or Firm* — Neugeboren O'Dowd PC

(51) **Int. Cl.**
H01J 37/32 (2006.01)
H01J 37/34 (2006.01)

(57) **ABSTRACT**

This disclosure describes a non-dissipative snubber circuit configured to boost a voltage applied to a load after the load's impedance rises rapidly. The voltage boost can thereby cause more rapid current ramping after a decrease in power delivery to the load which results from the load impedance rise. In particular, the snubber can comprise a combination of a unidirectional switch, a voltage multiplier, and a current limiter. In some cases, these components can be a diode, voltage doubler, and an inductor, respectively.

(52) **U.S. Cl.**
CPC **H01J 37/32064** (2013.01); **H01J 37/34**
(2013.01)

32 Claims, 30 Drawing Sheets

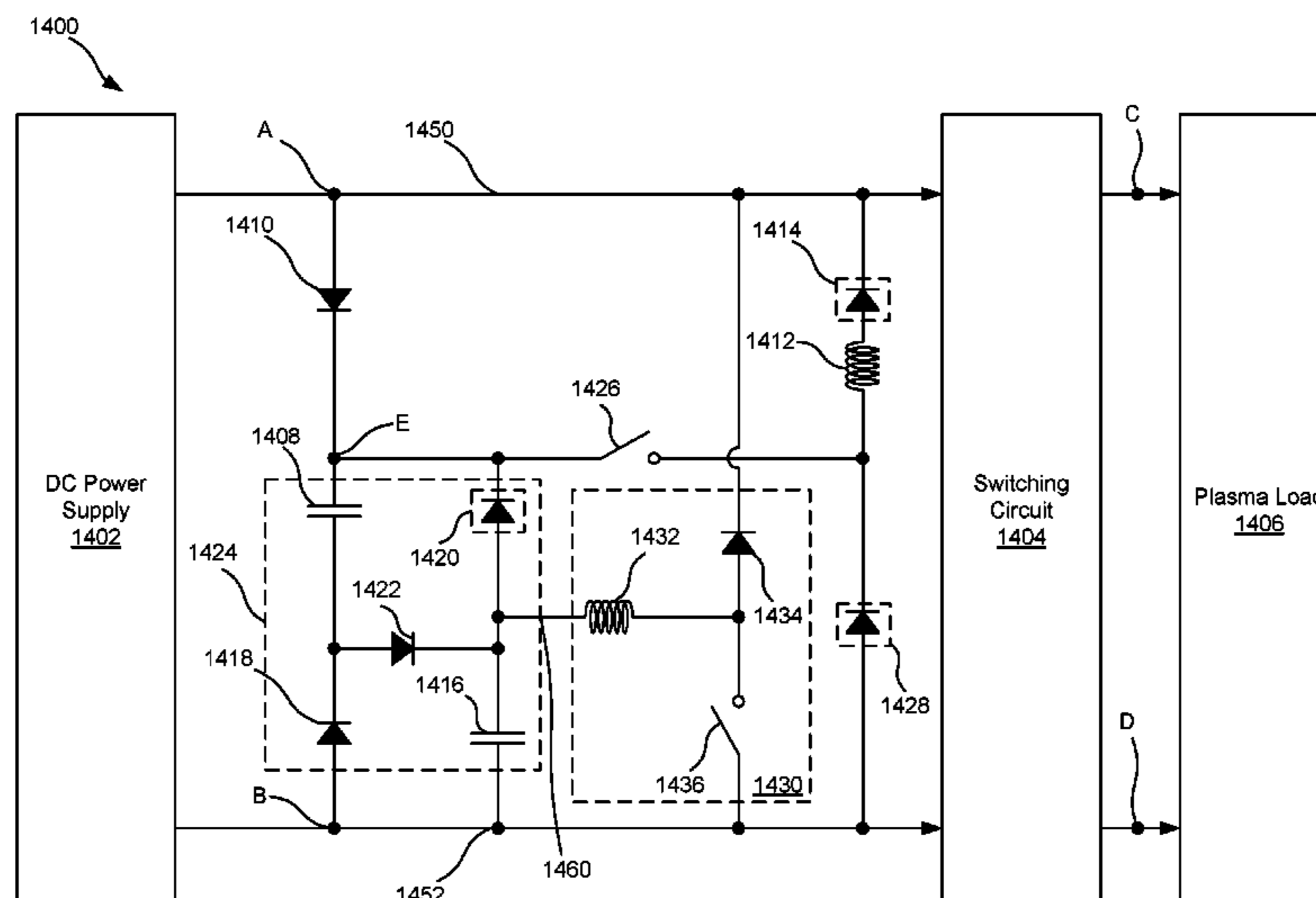

(56)

References Cited

U.S. PATENT DOCUMENTS

2011/0120861 A1* 5/2011 Horishita C23C 14/3464
 204/298.08
 2011/0248633 A1* 10/2011 Nauman C23C 14/3485
 315/111.21
 2012/0025726 A1* 2/2012 Watanabe H01J 37/32027
 315/205
 2014/0159648 A1 6/2014 Sadwick

OTHER PUBLICATIONS

Gruber, Stephen S., "Response to Restriction Requirement re U.S. Appl. No. 14/184,968", Sep. 23, 2015, p. 7, Published in: US.
 King, Monica C., "Office Action re U.S. Appl. No. 15/055,761", Sep. 2, 2016, p. 7 Published in: US.
 King, Monica C., "Office Action re U.S. Appl. No. 14/945,324", Jun. 10, 2016, p. 24 Published in: US.
 Gruber, Stephen S., "Response to Office Action re U.S. Appl. No. 14/945,324", Jul. 8, 2016, p. 9 Published in: US.

Belkind, A. et al., "Characterization of Pulsed DC Magnetron Sputtering Plasmas", Apr. 6, 2005, p. 19 vol. 7, No. 1, Publisher: New Journal of Physics.

Christie, et al., "High performance pulsed current source supplies for large area", Nov. 2, 2000, p. 12 Published in: US.

King, Monica C., "Office Action re U.S. Appl. No. 13/666,668", Jan. 30, 2015, p. 6 Published in: US.

O'Dowd, Sean R., "Response to Office Action re U.S. Appl. No. 13/666,688", Mar. 27, 2015, p. 8 Published in: US.

Koh, Eugene, "International Search Report and Written Opinion re Application No. PCT/US2013/068033", Feb. 3, 2014, p. 17 Published in: AU.

Sittinger, et al., "Position and Time Resolved Optical Emission Spectroscopy and Film Properties of", 2007, p. 6, Published in: US.

Todd, Philip C., "Snubber Circuits: Theory, Design and Application", "Unitrode Corporation", May 1993, pp. 2-1 through 2-17, Publisher: Texas Instruments, Published in: US.

Wittmann-Regis, Agnes, "International Preliminary Report on Patentability re Application No. PCT/US2013/068033", May 14, 2015, p. 12, Published in: US.

* cited by examiner

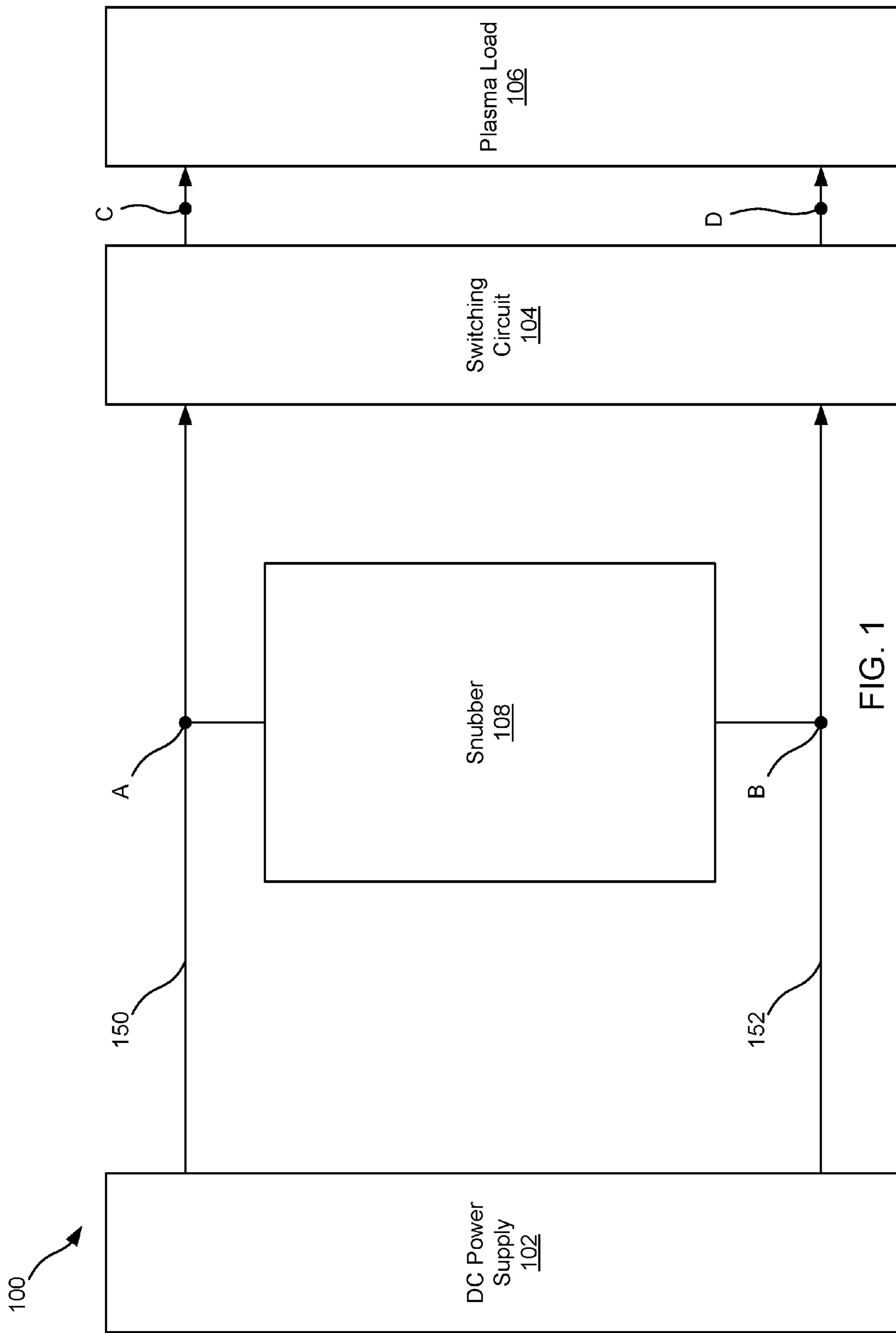

FIG. 1

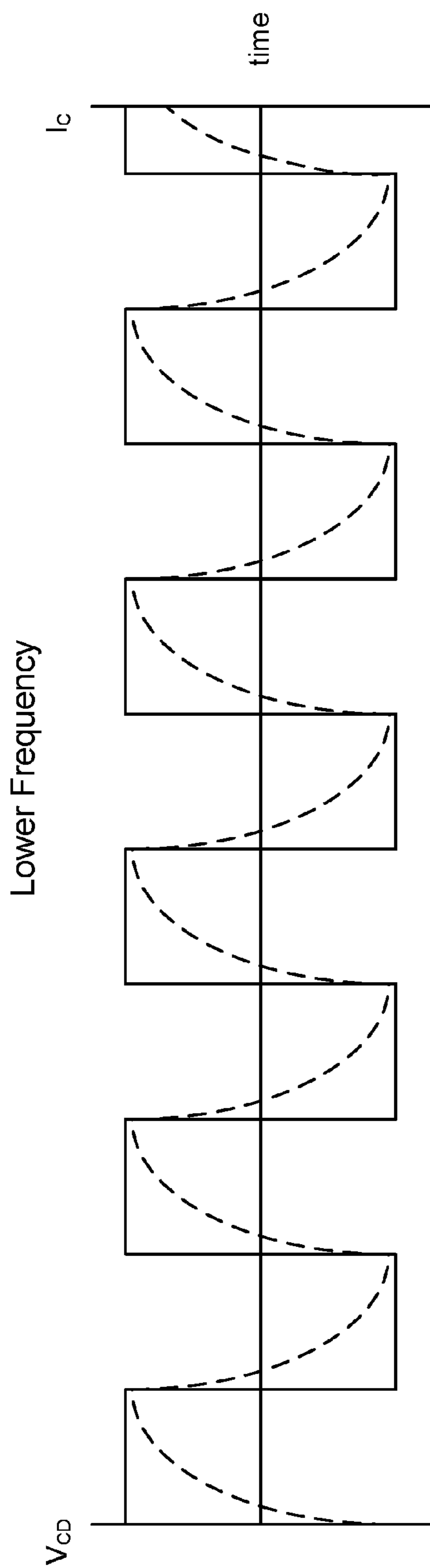

FIG. 2A

Voltage ———
Current - - - -

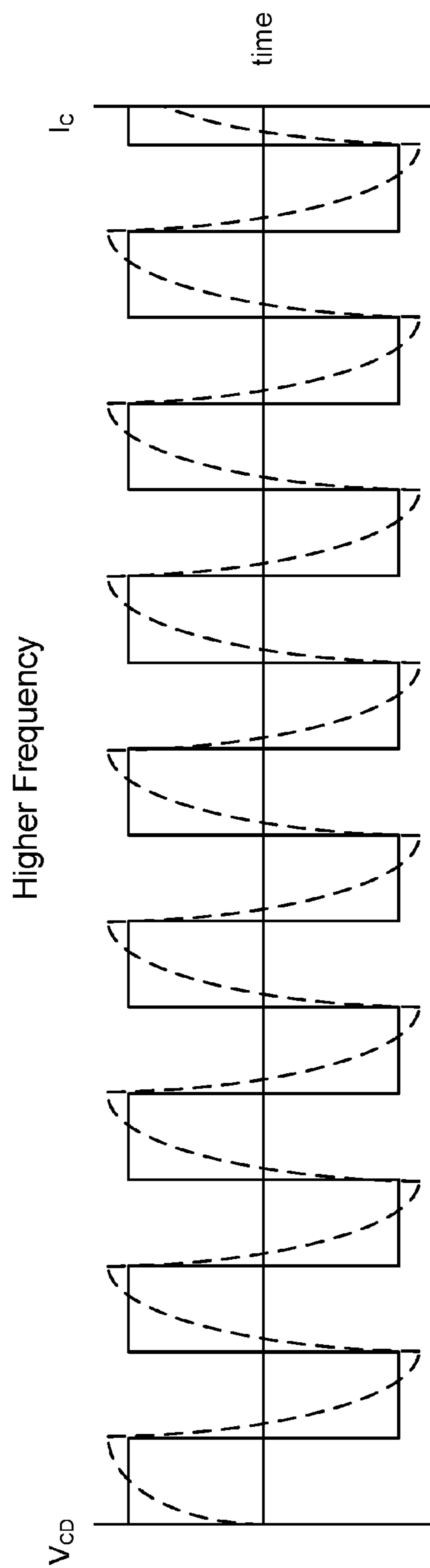

FIG. 2B

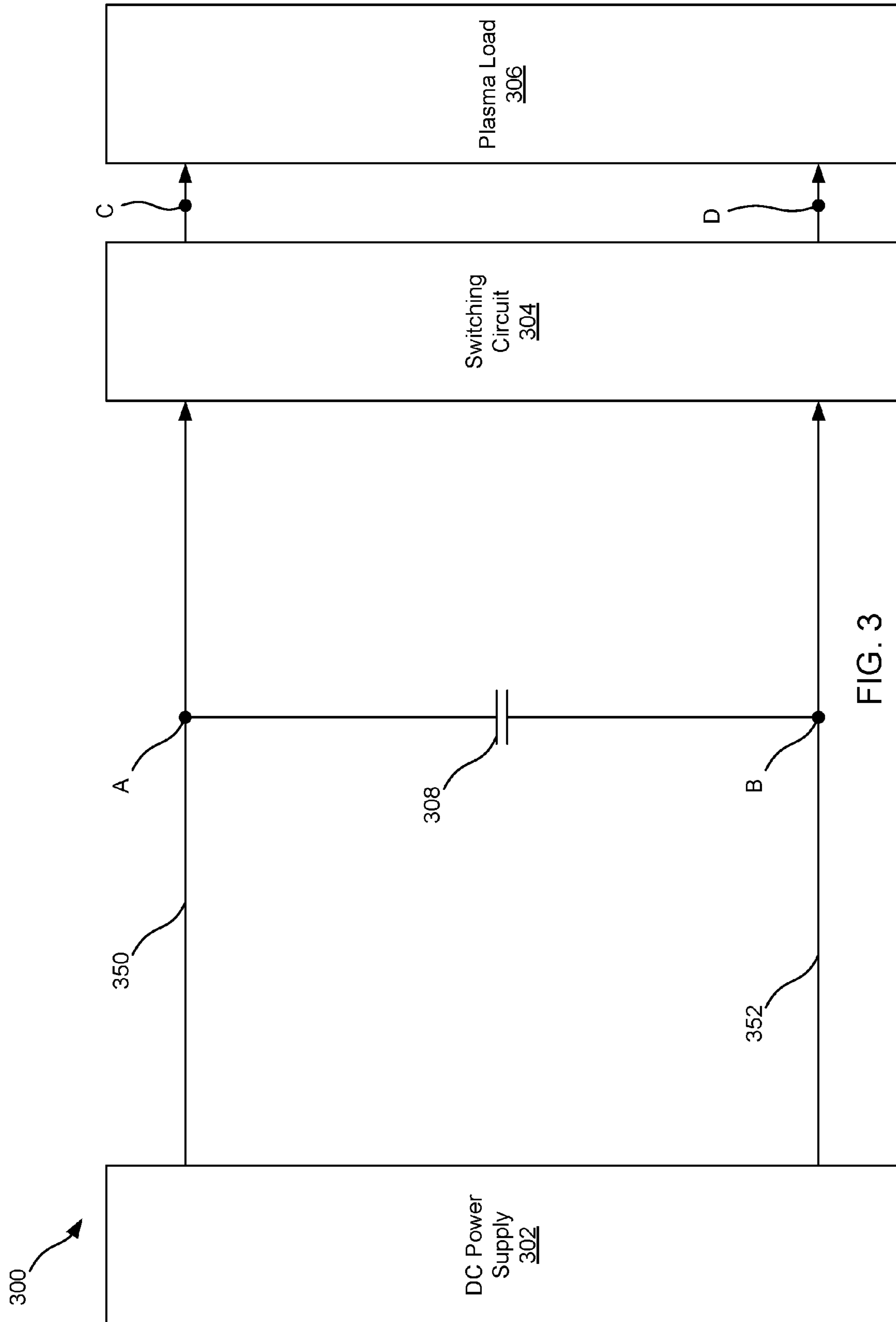

FIG. 3

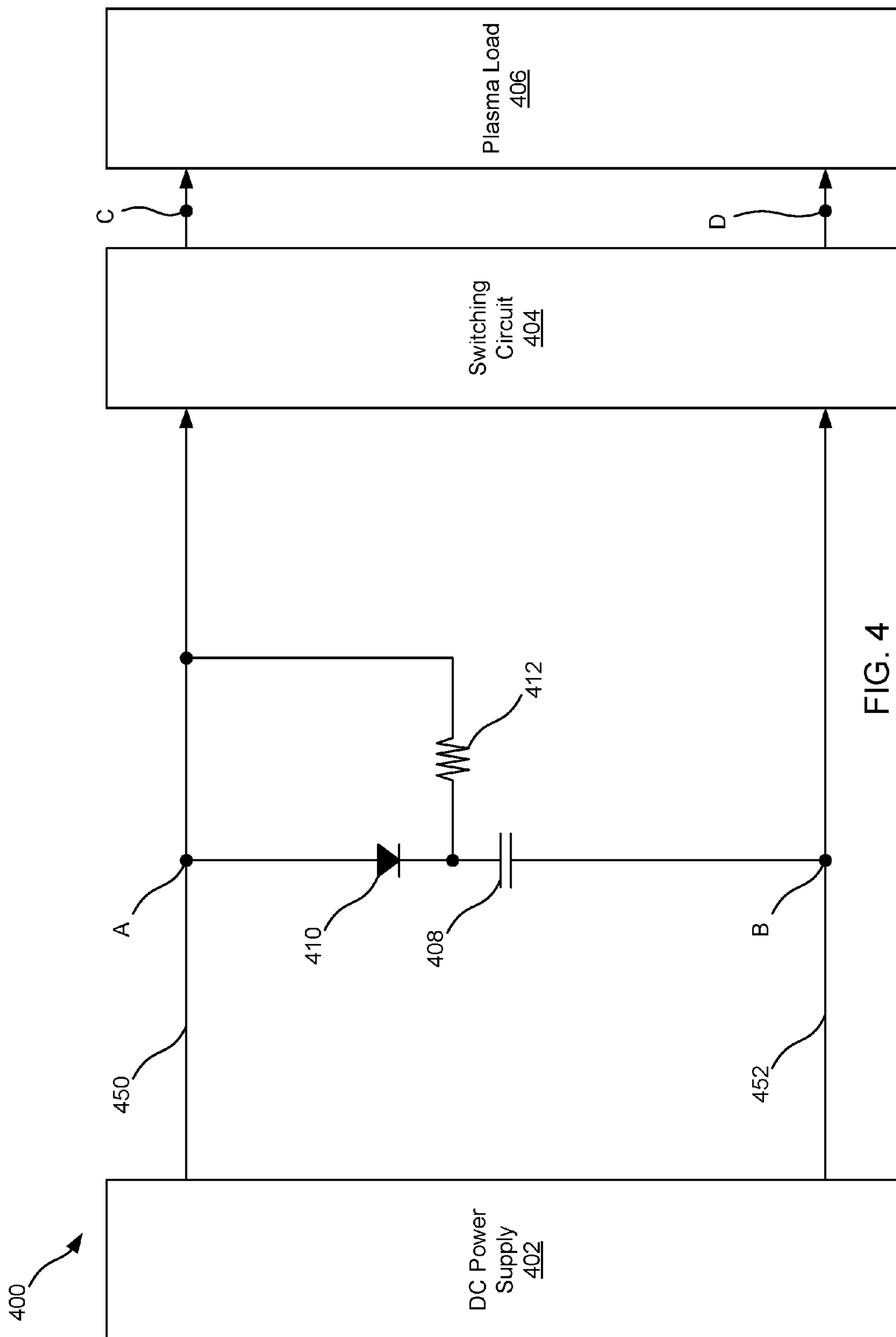

FIG. 4

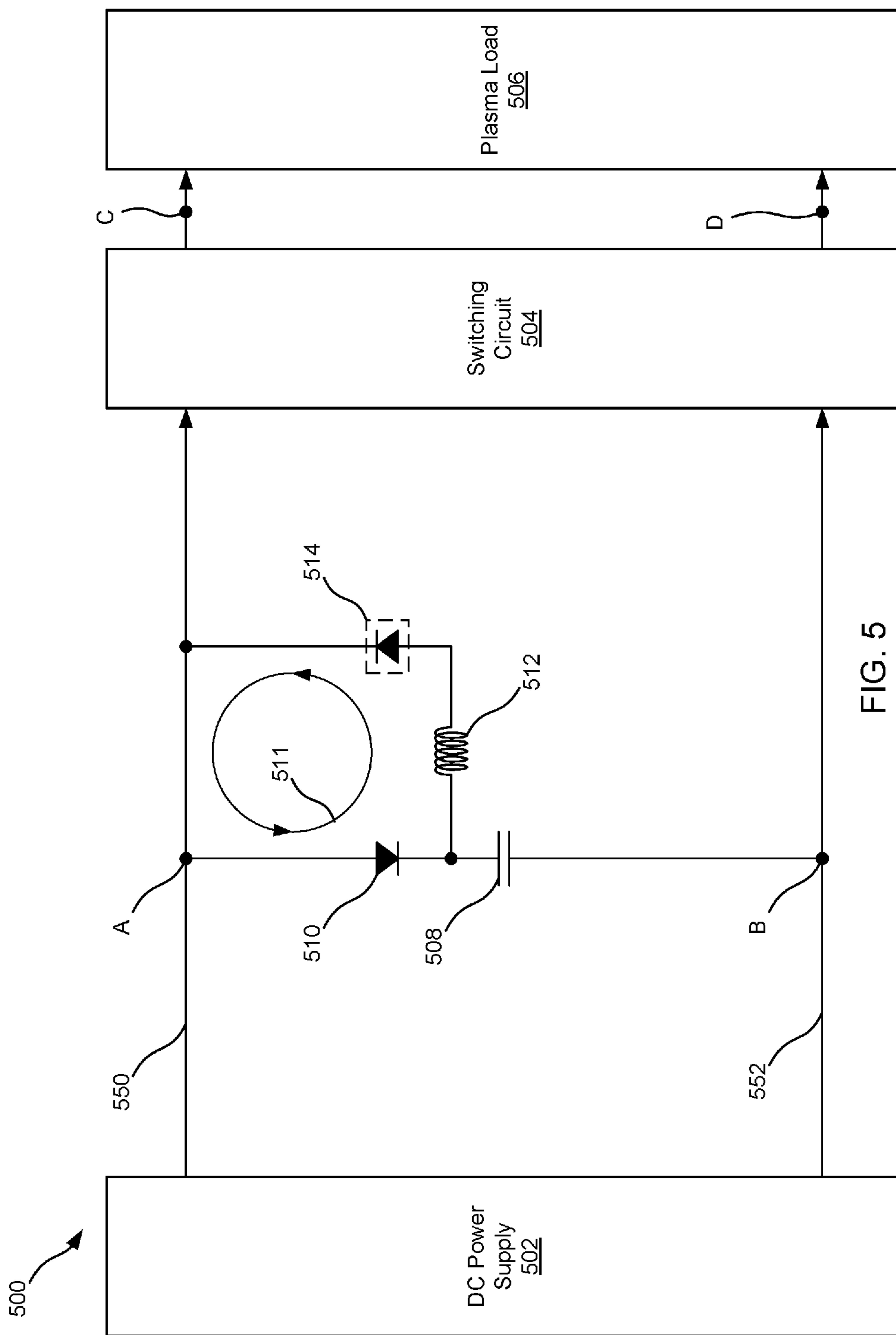

FIG. 5

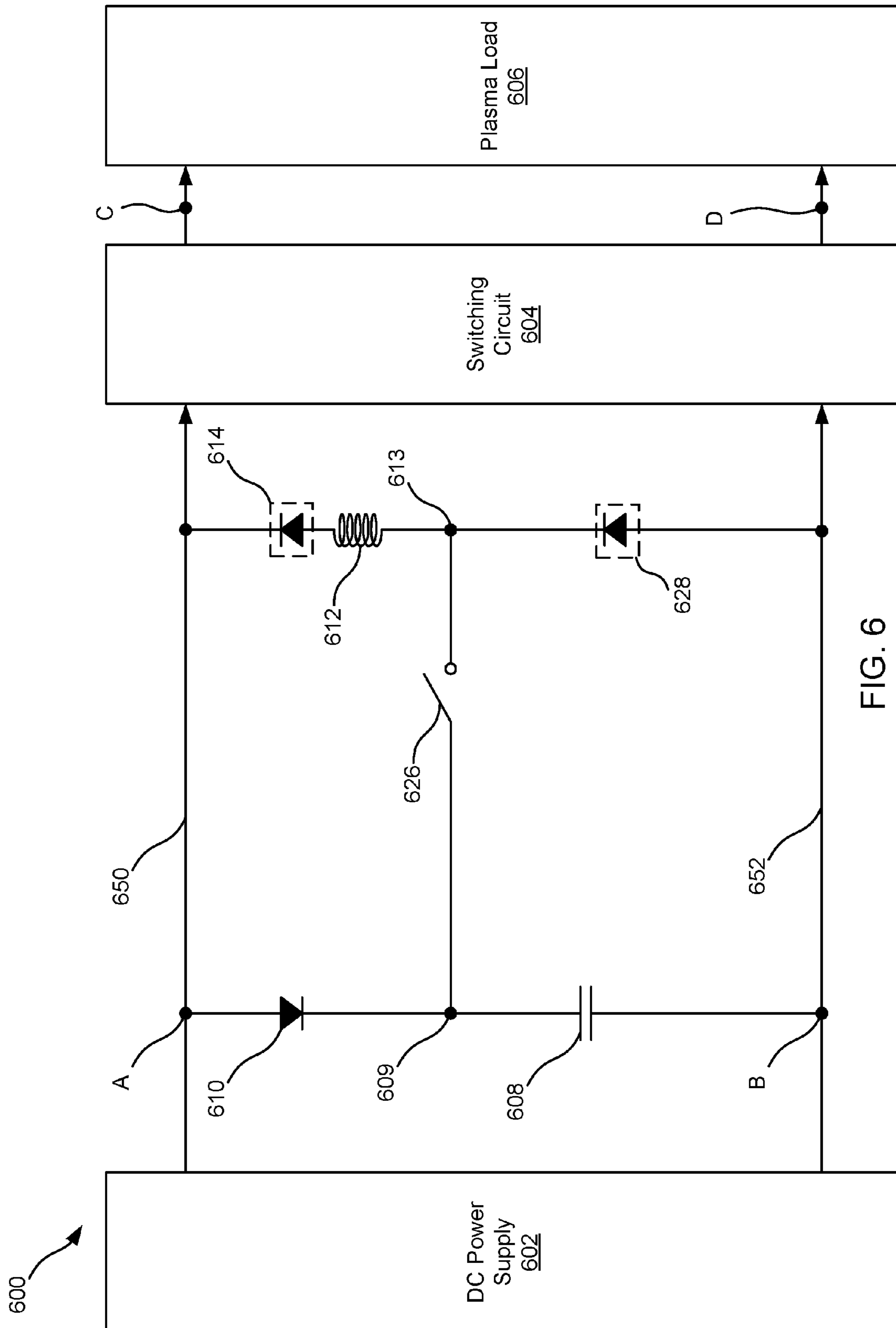

FIG. 6

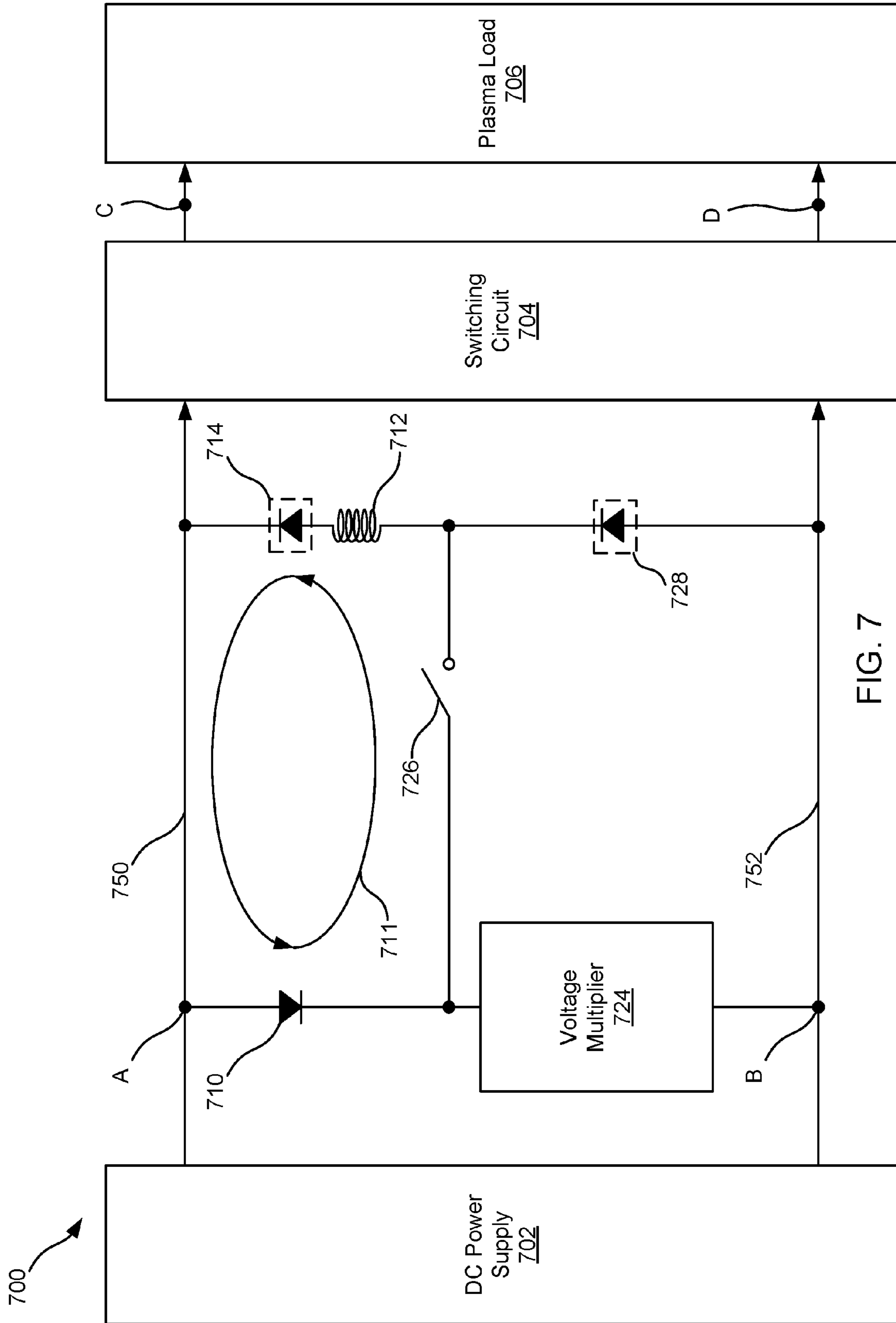

FIG. 7

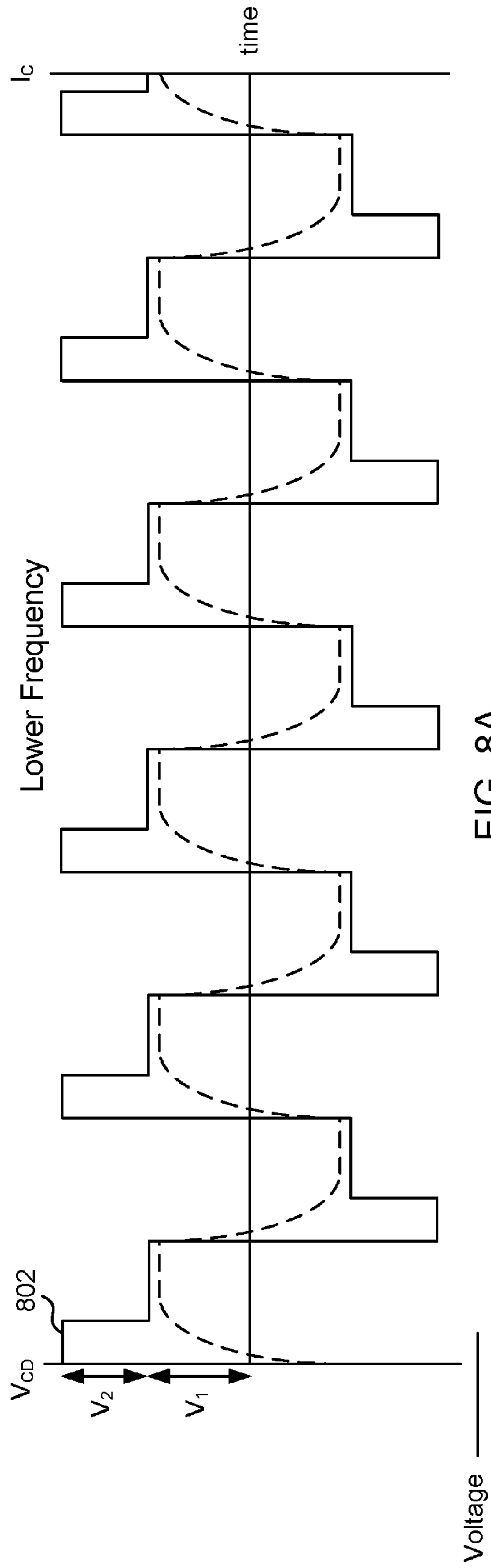

FIG. 8A

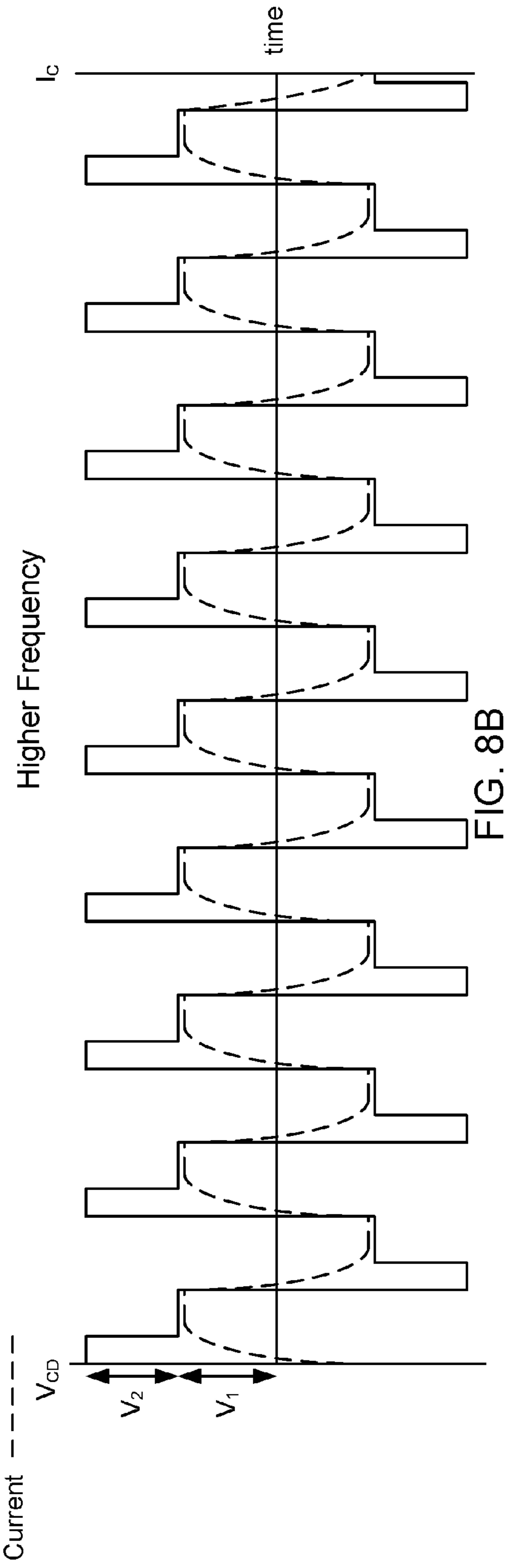

FIG. 8B

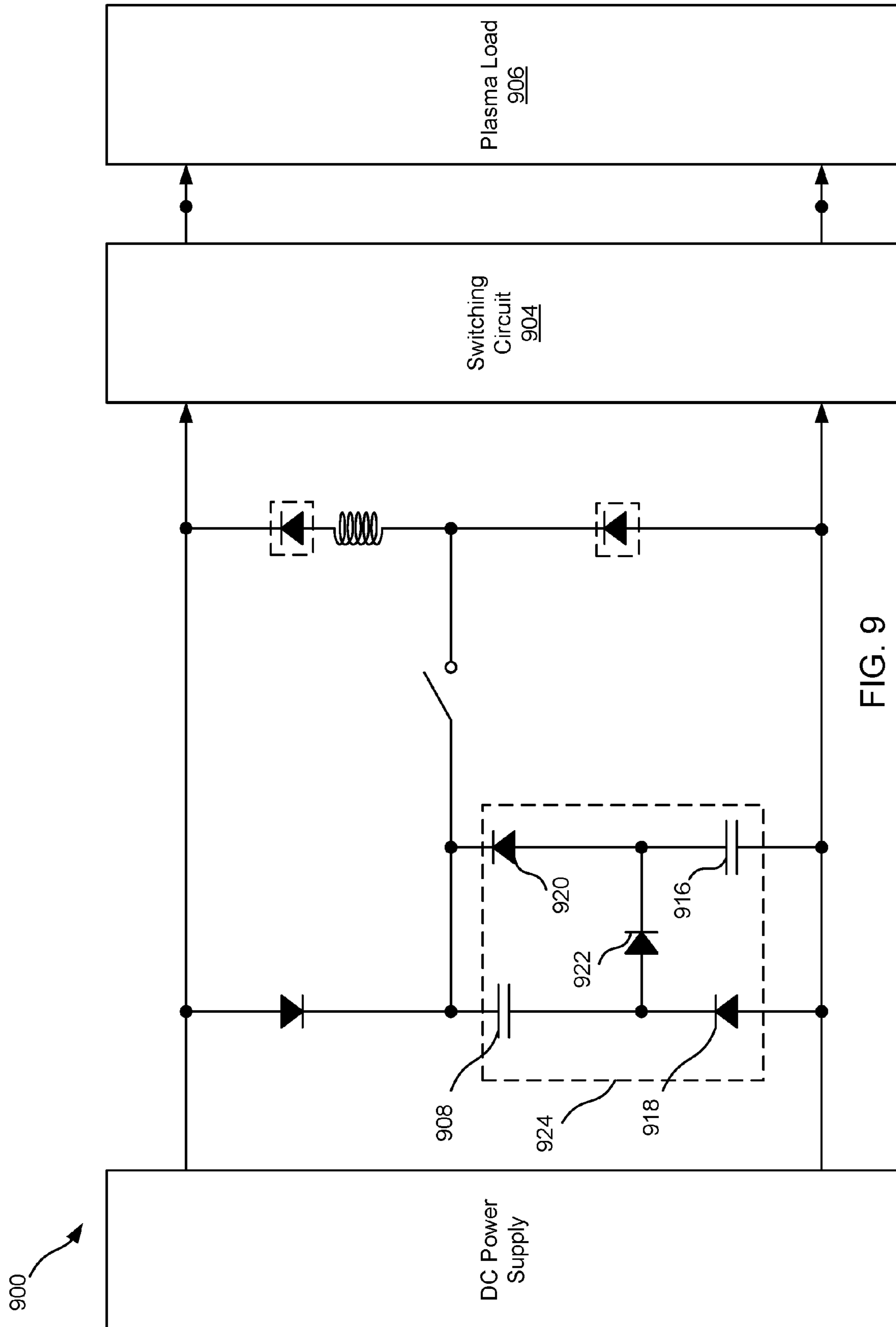
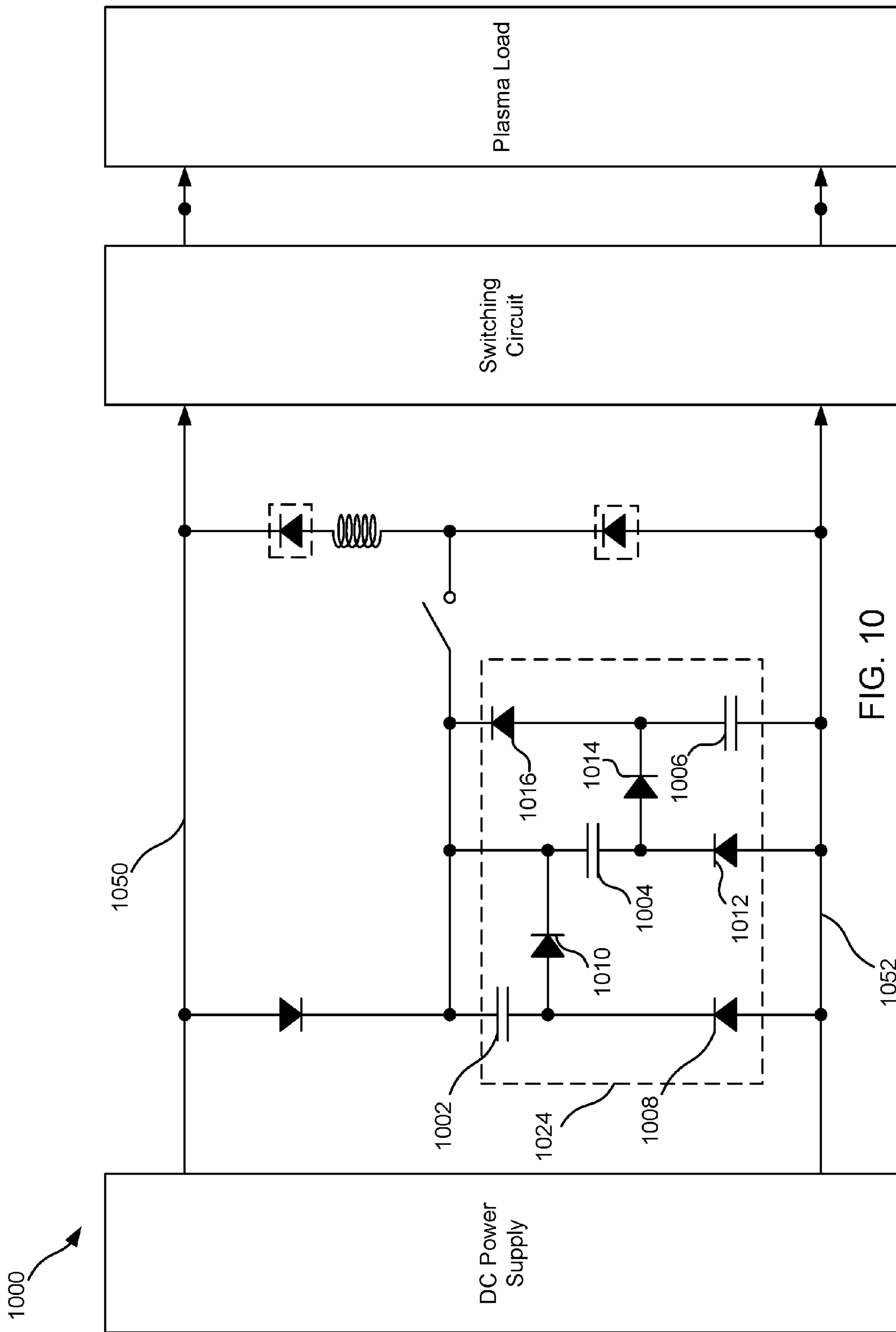

FIG. 9



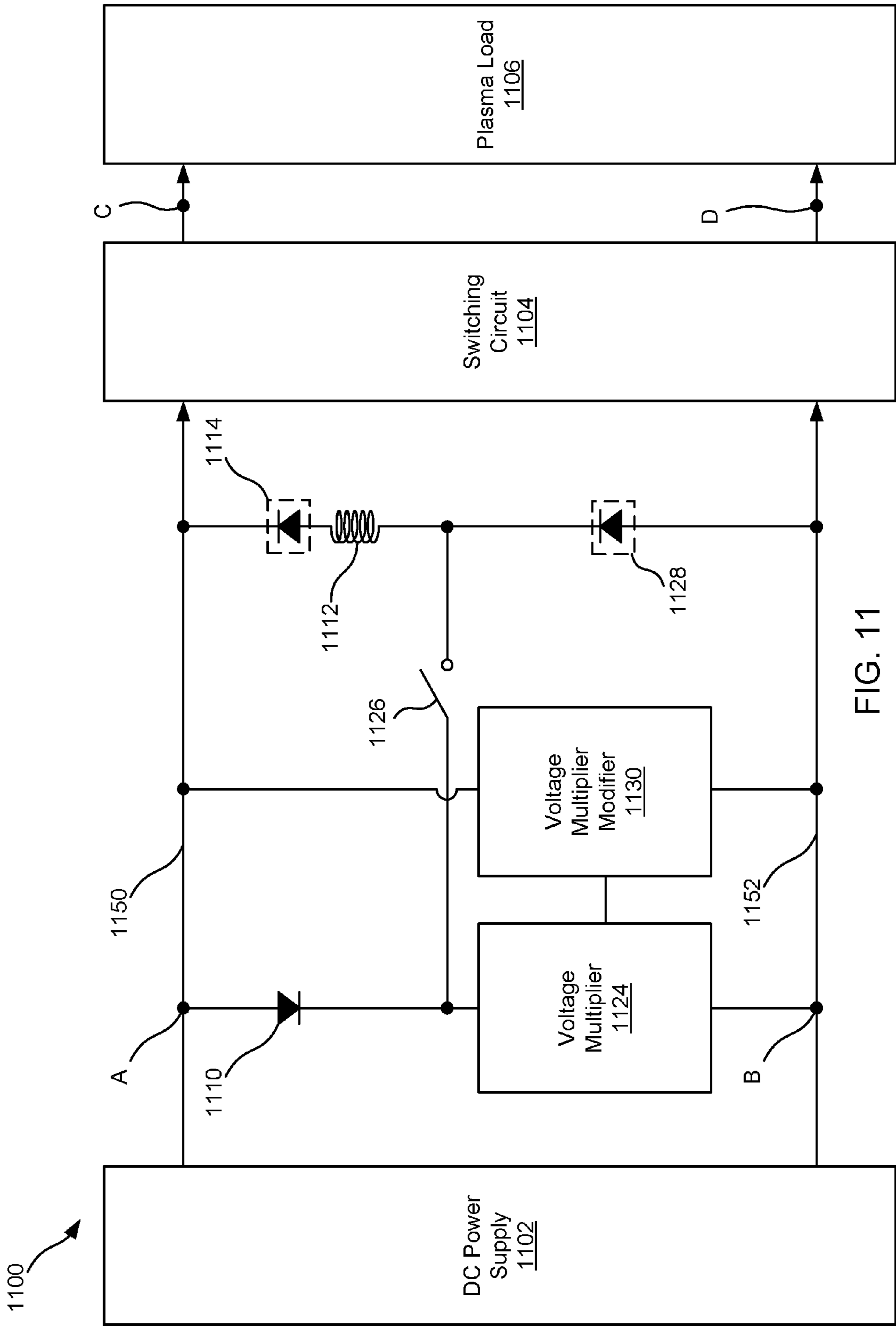

FIG. 11

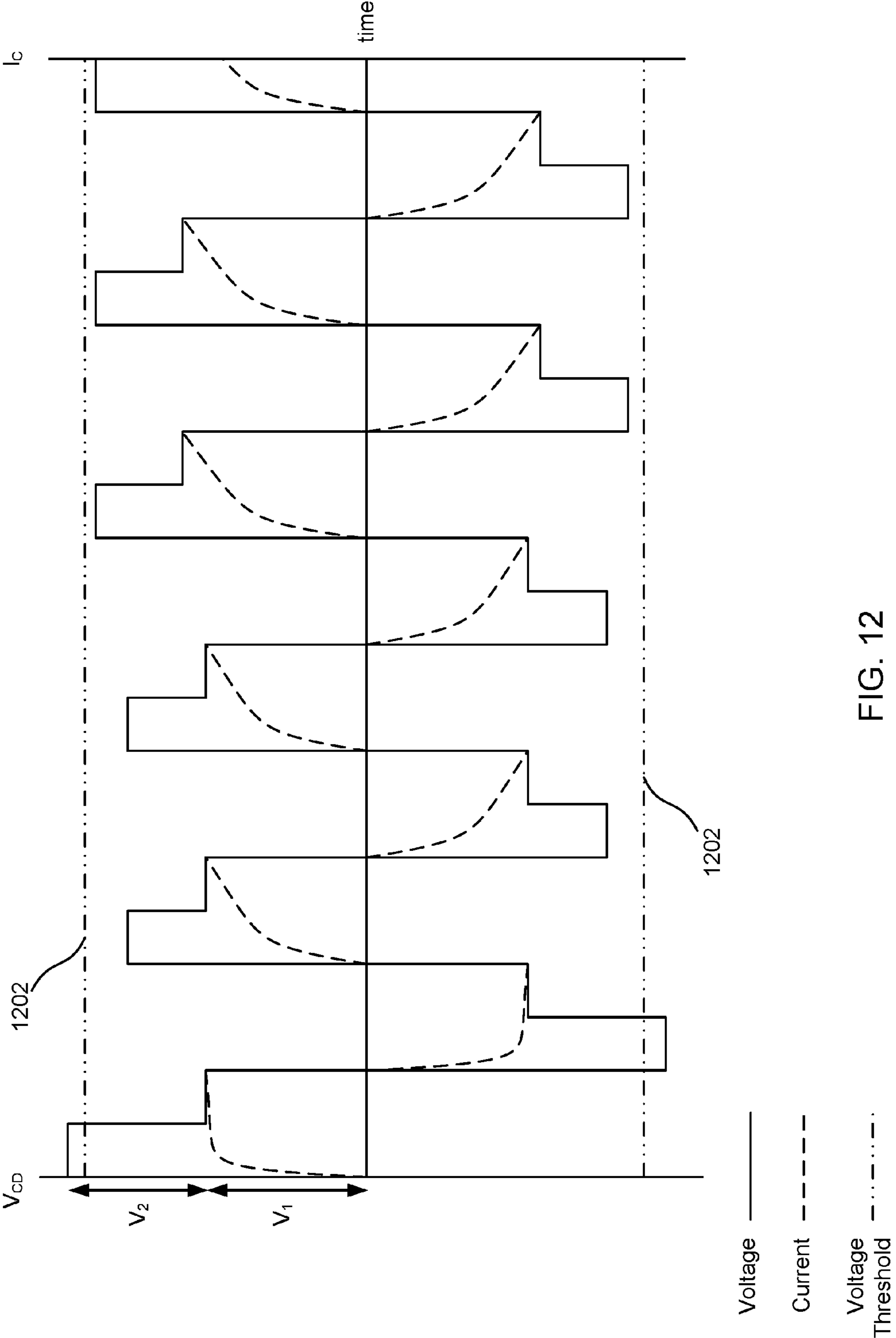

FIG. 12

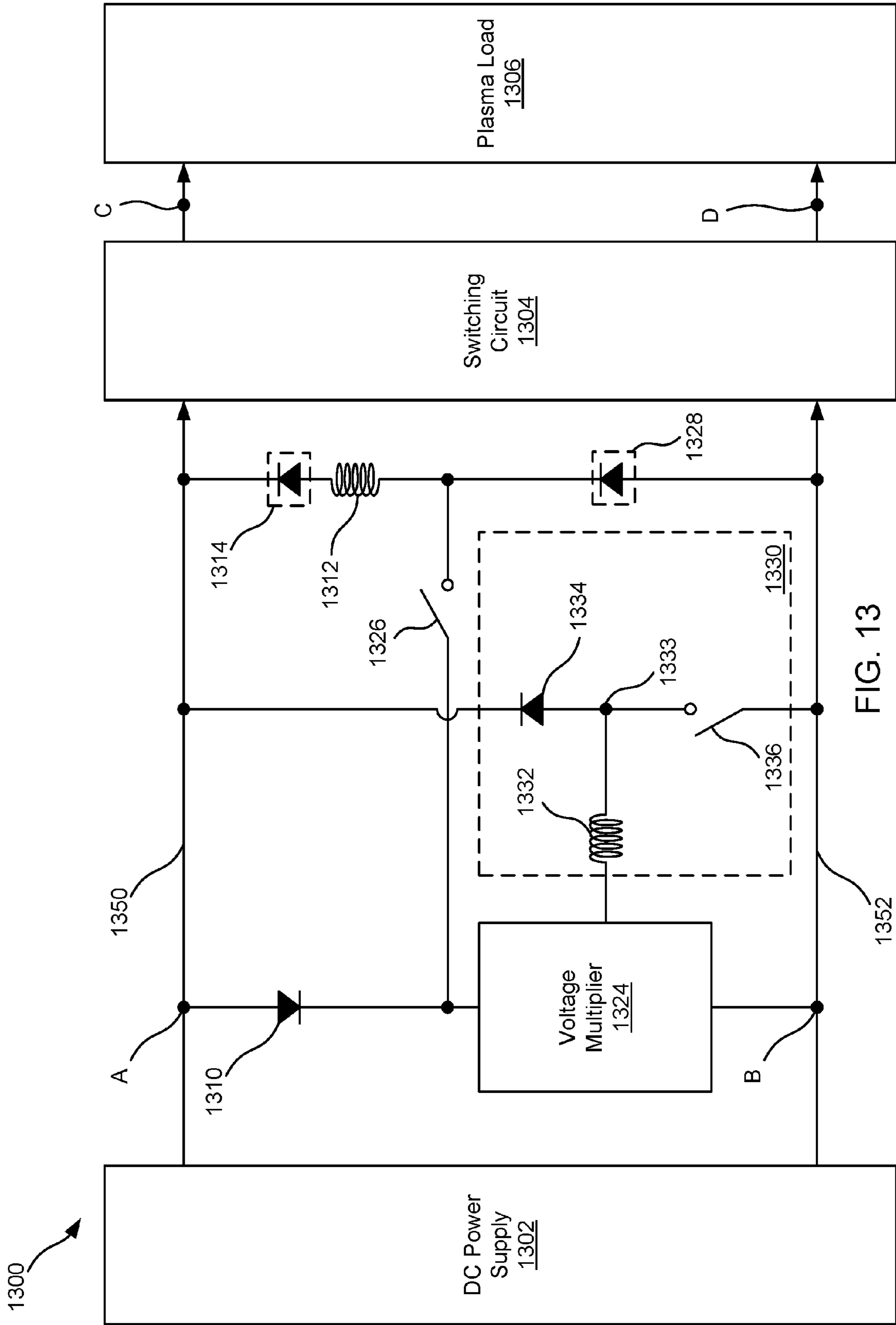

FIG. 13

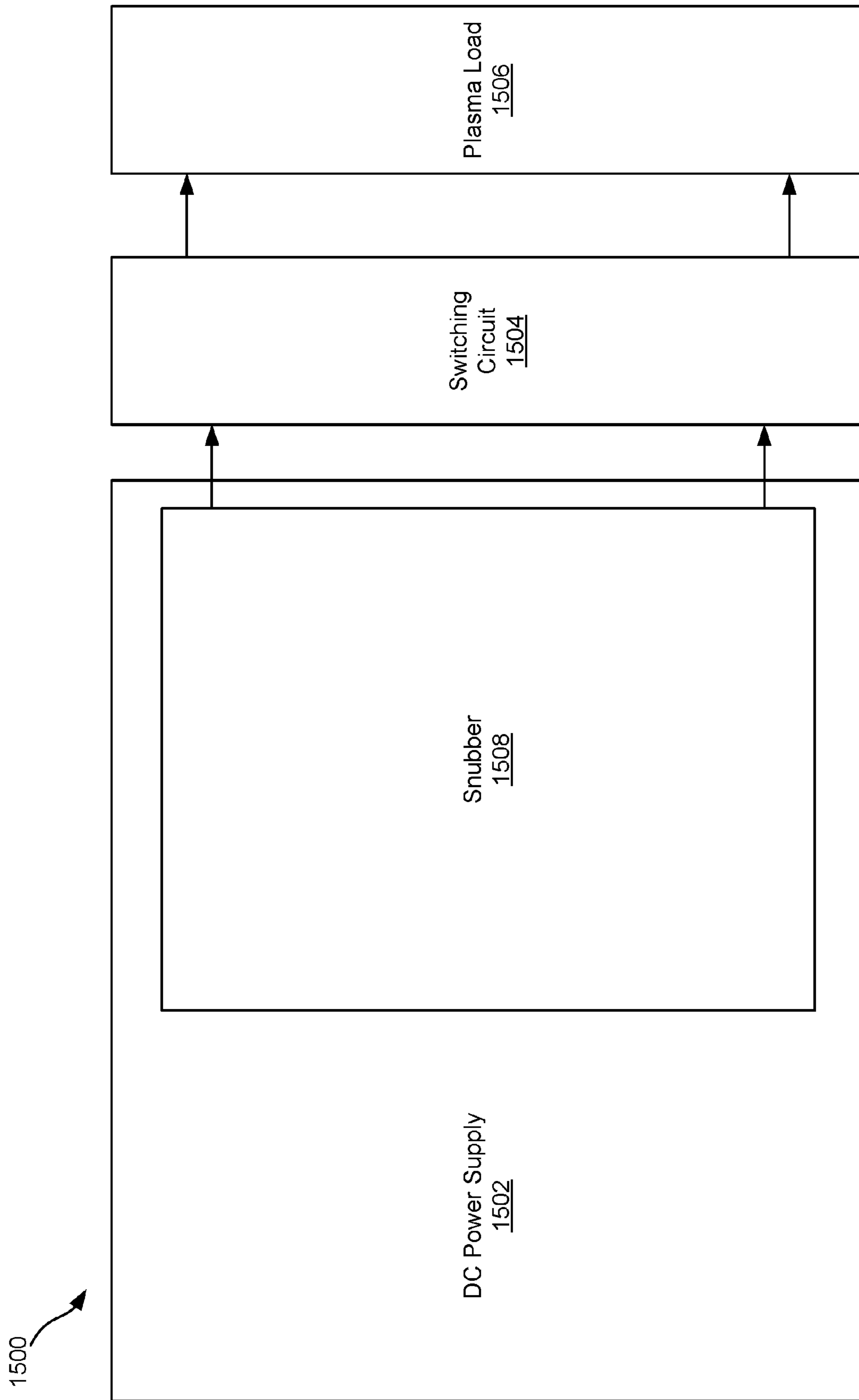

FIG. 15

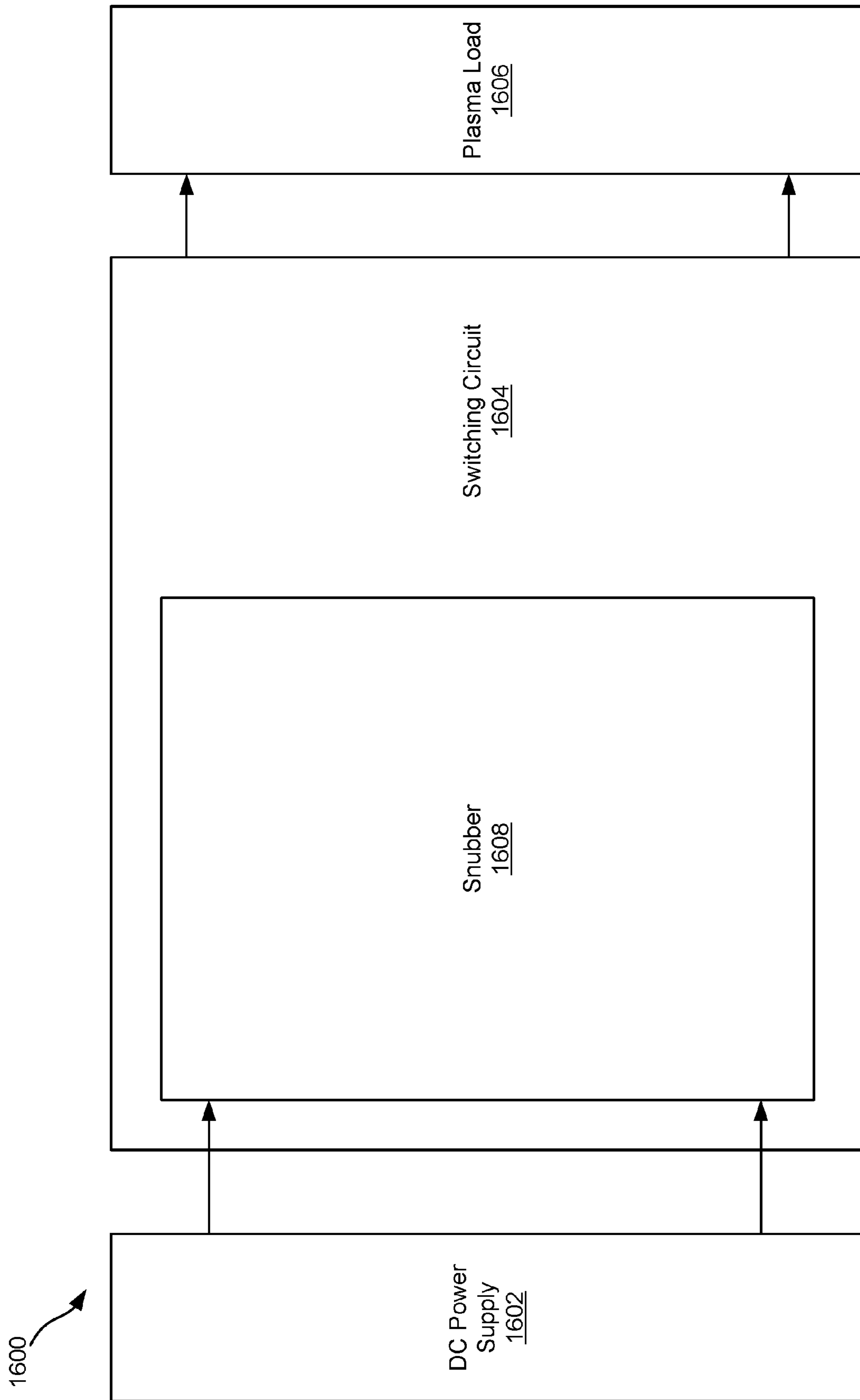

FIG. 16

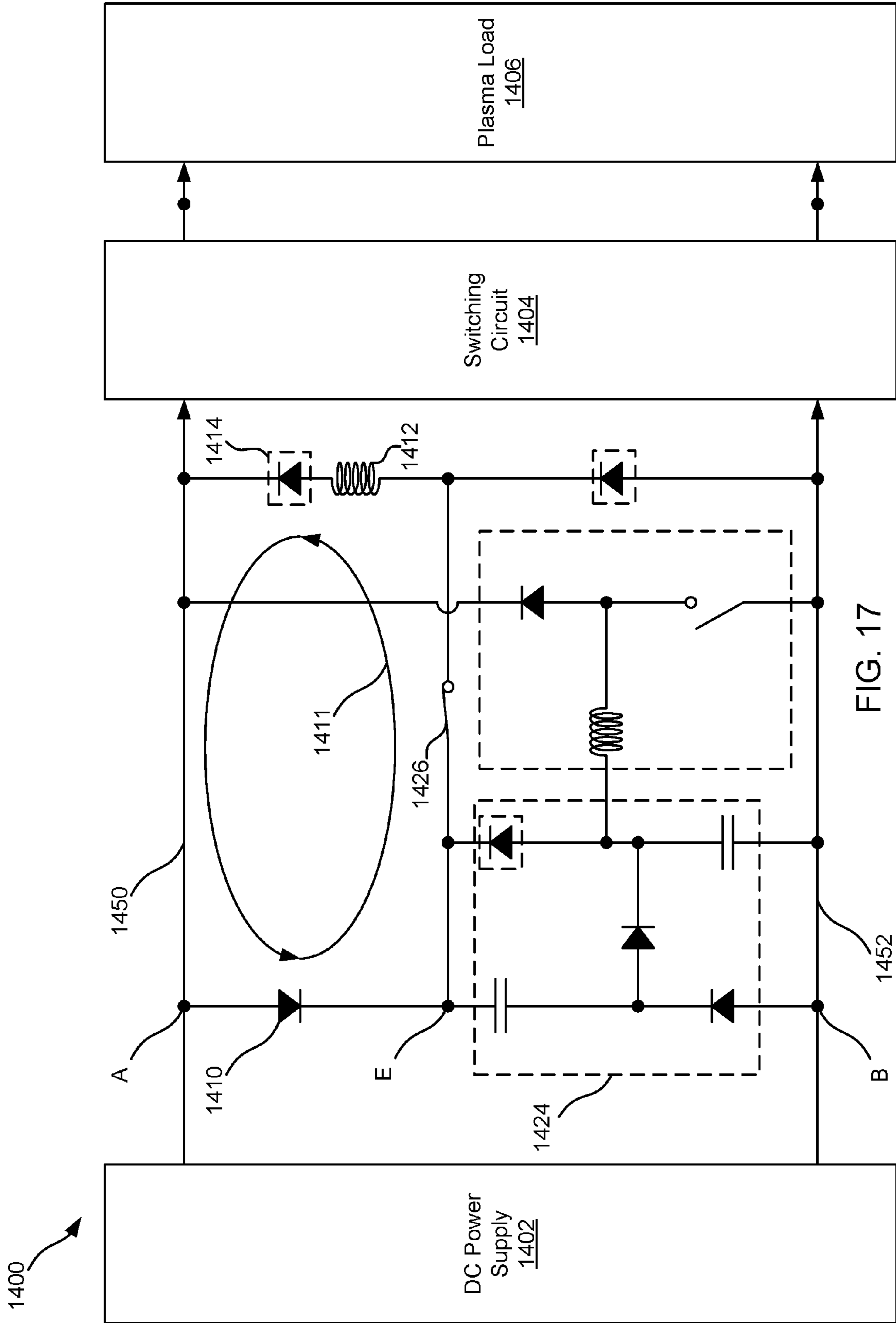

FIG. 17

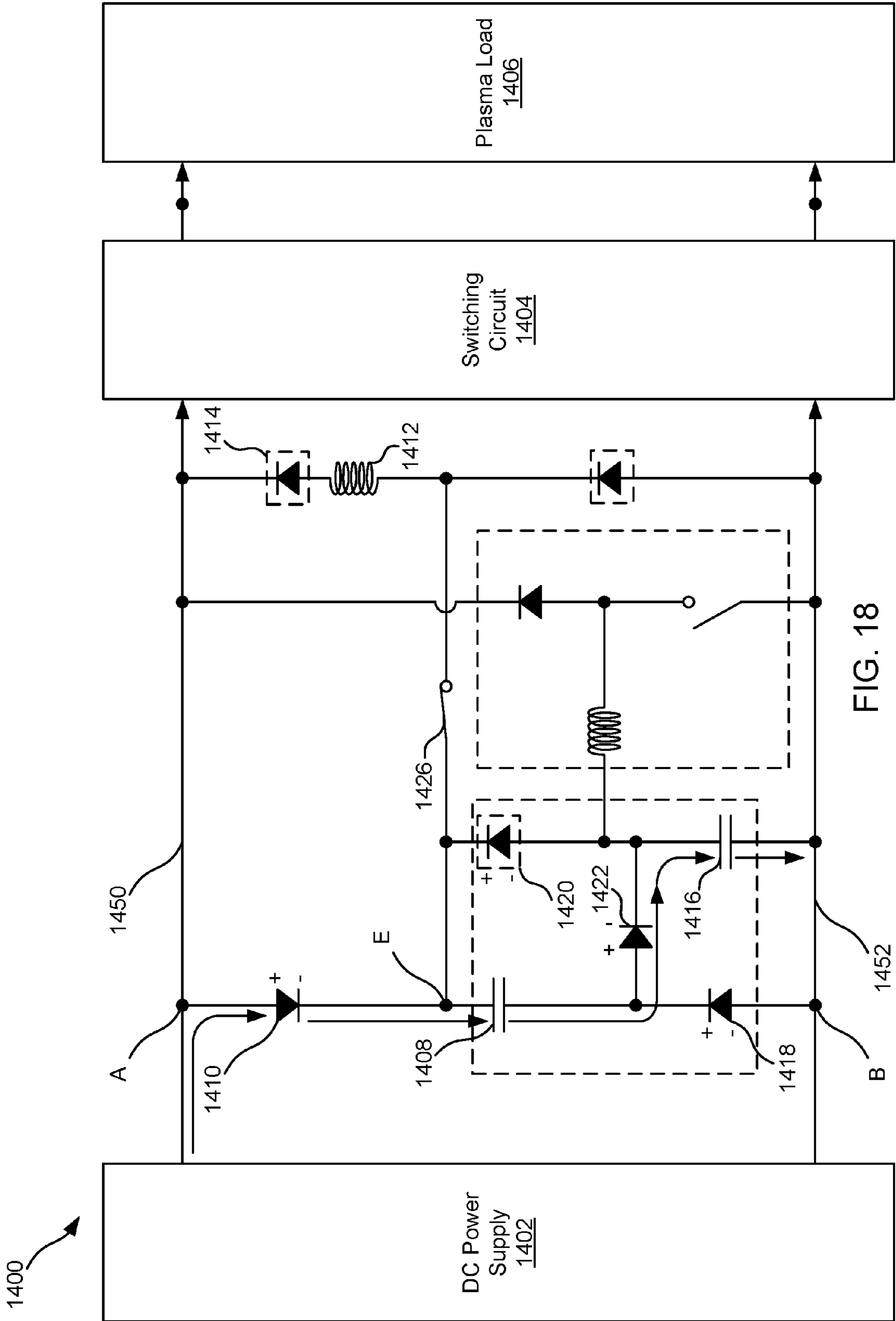

FIG. 18

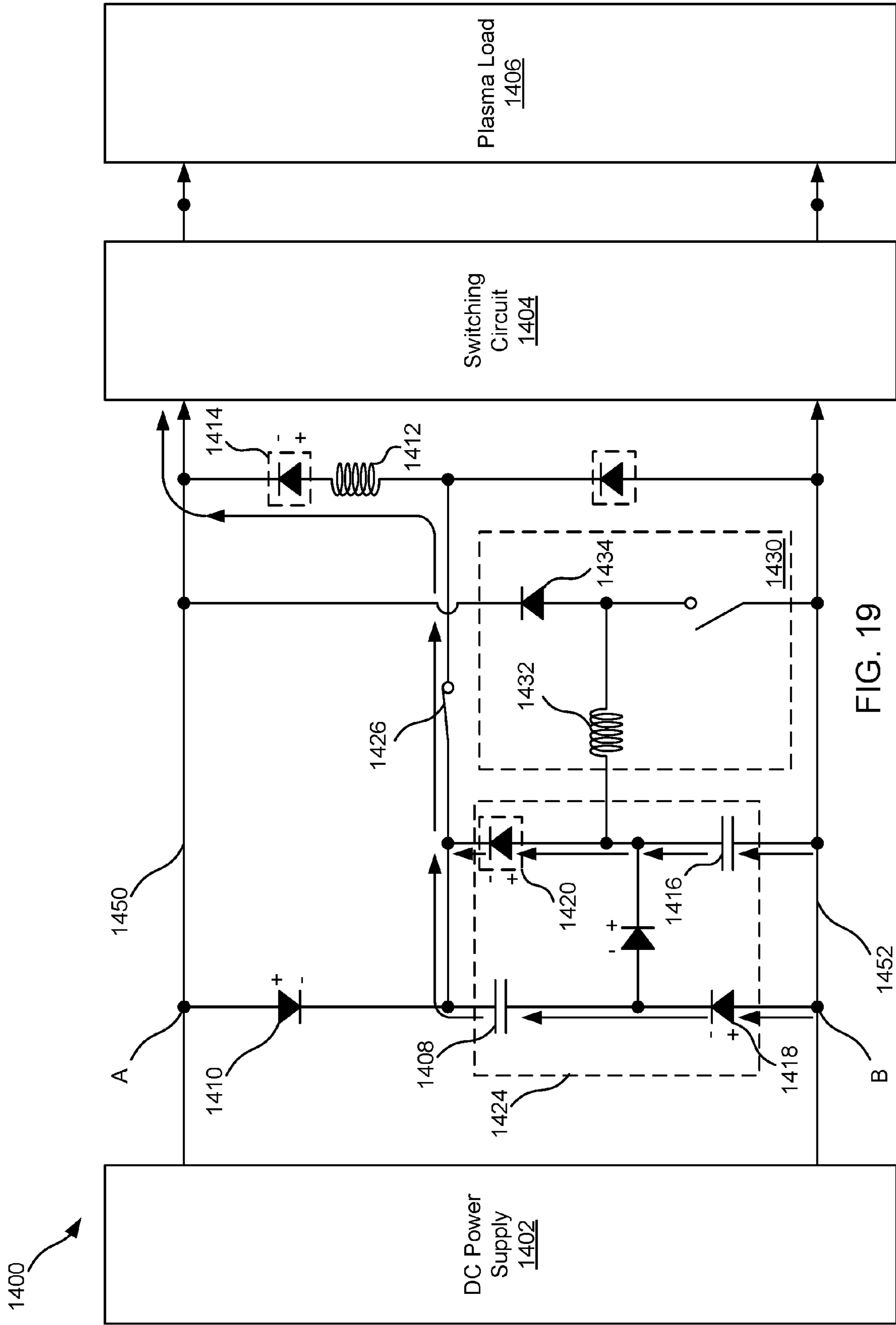
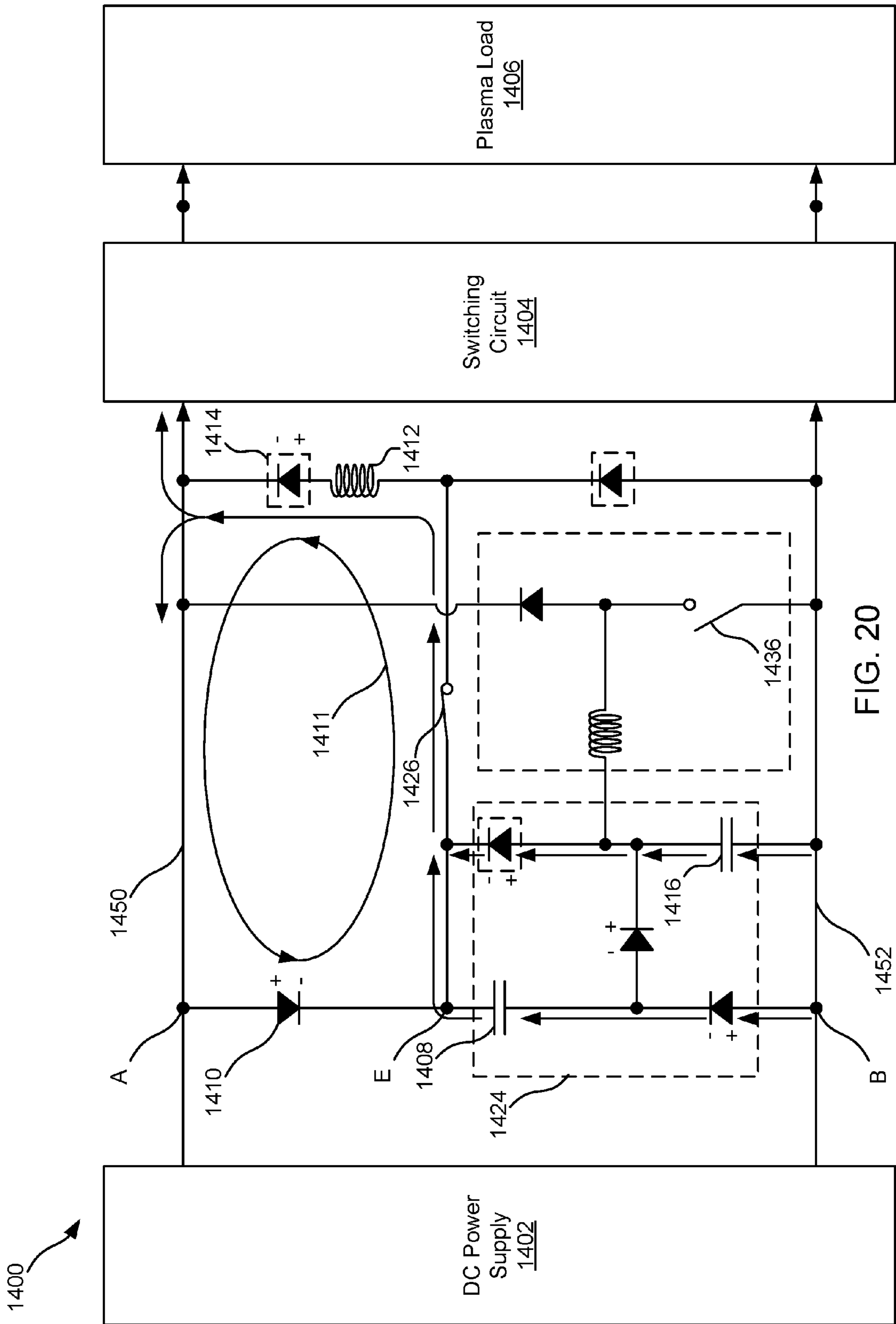

FIG. 19



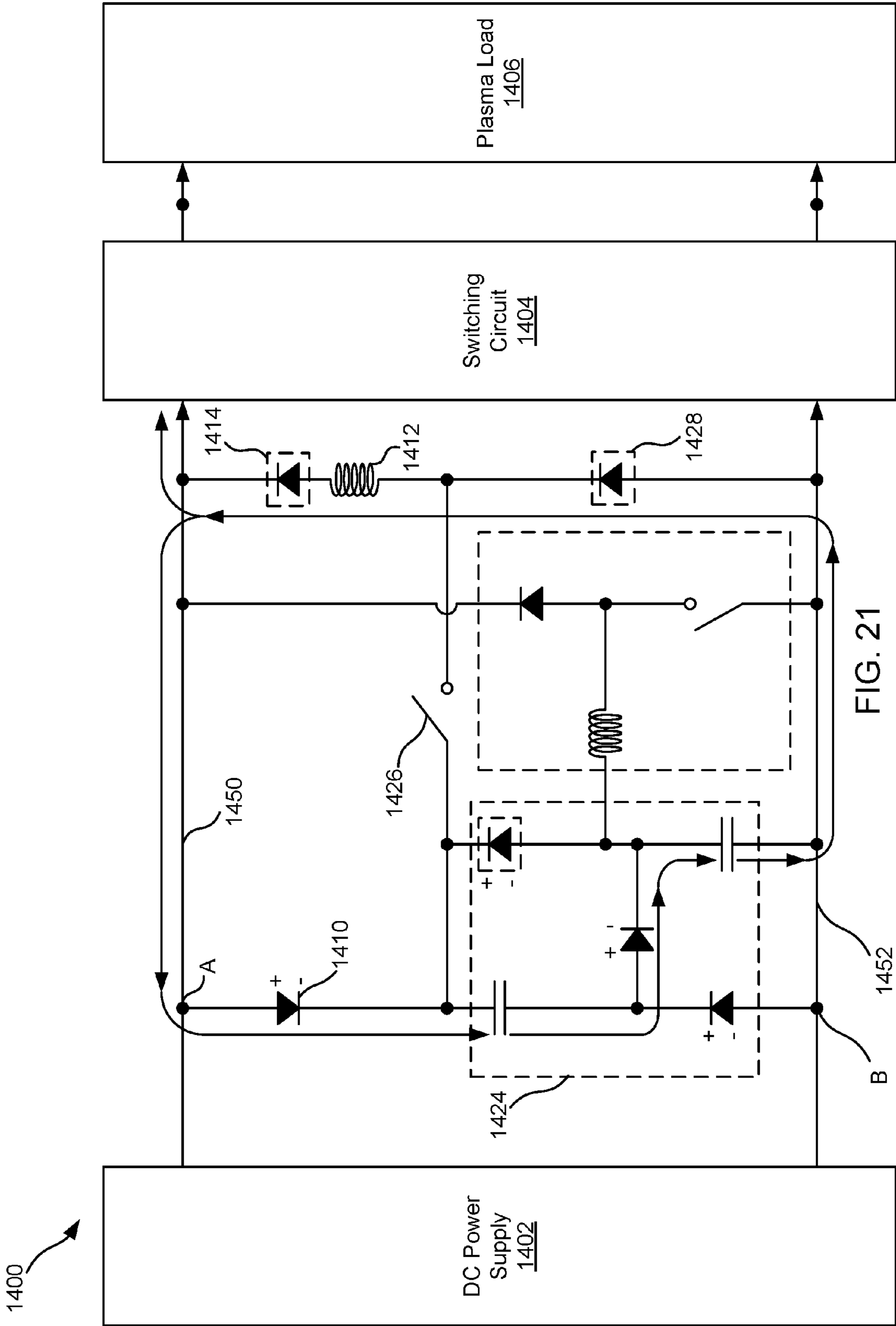

FIG. 21

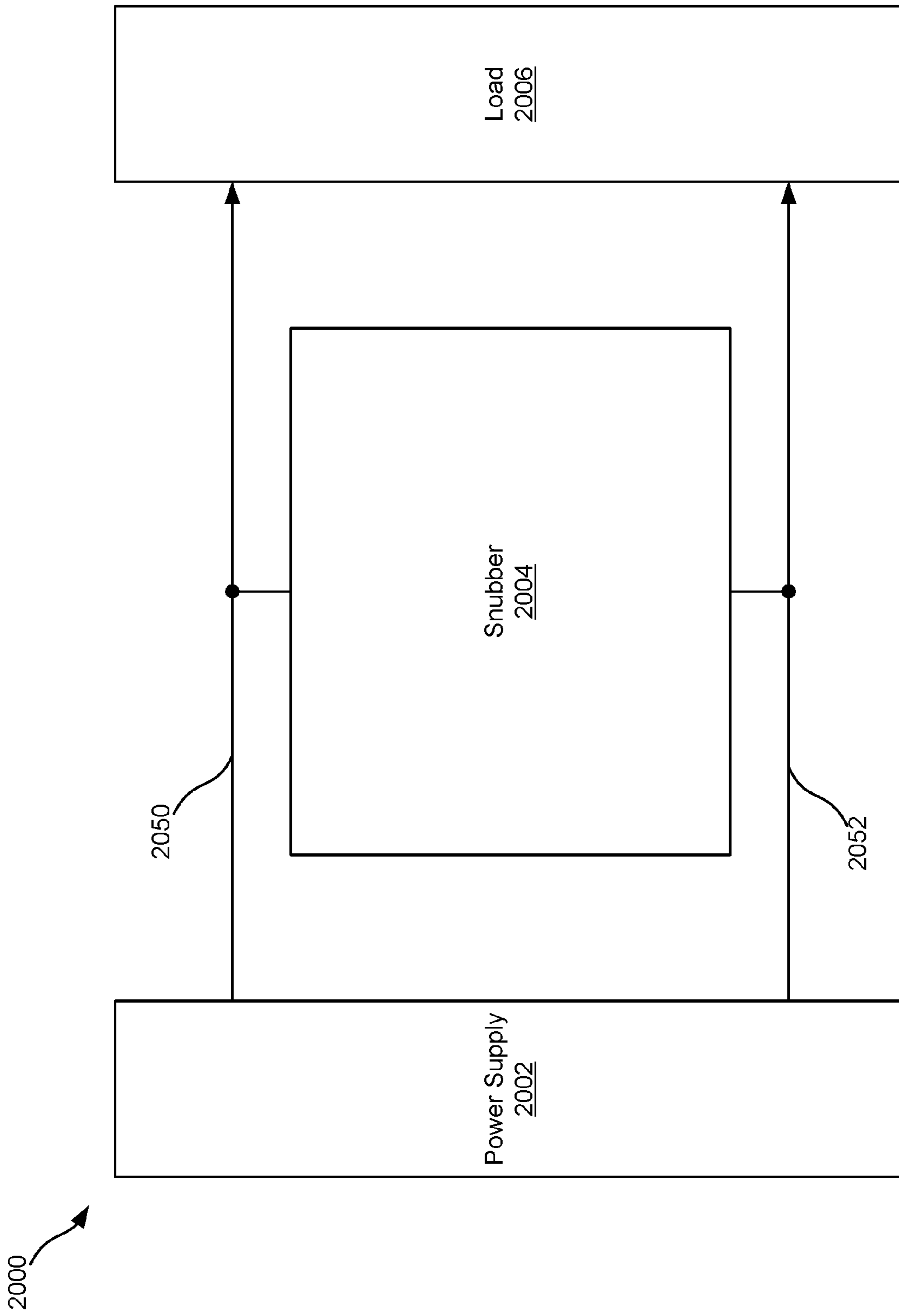

FIG. 22

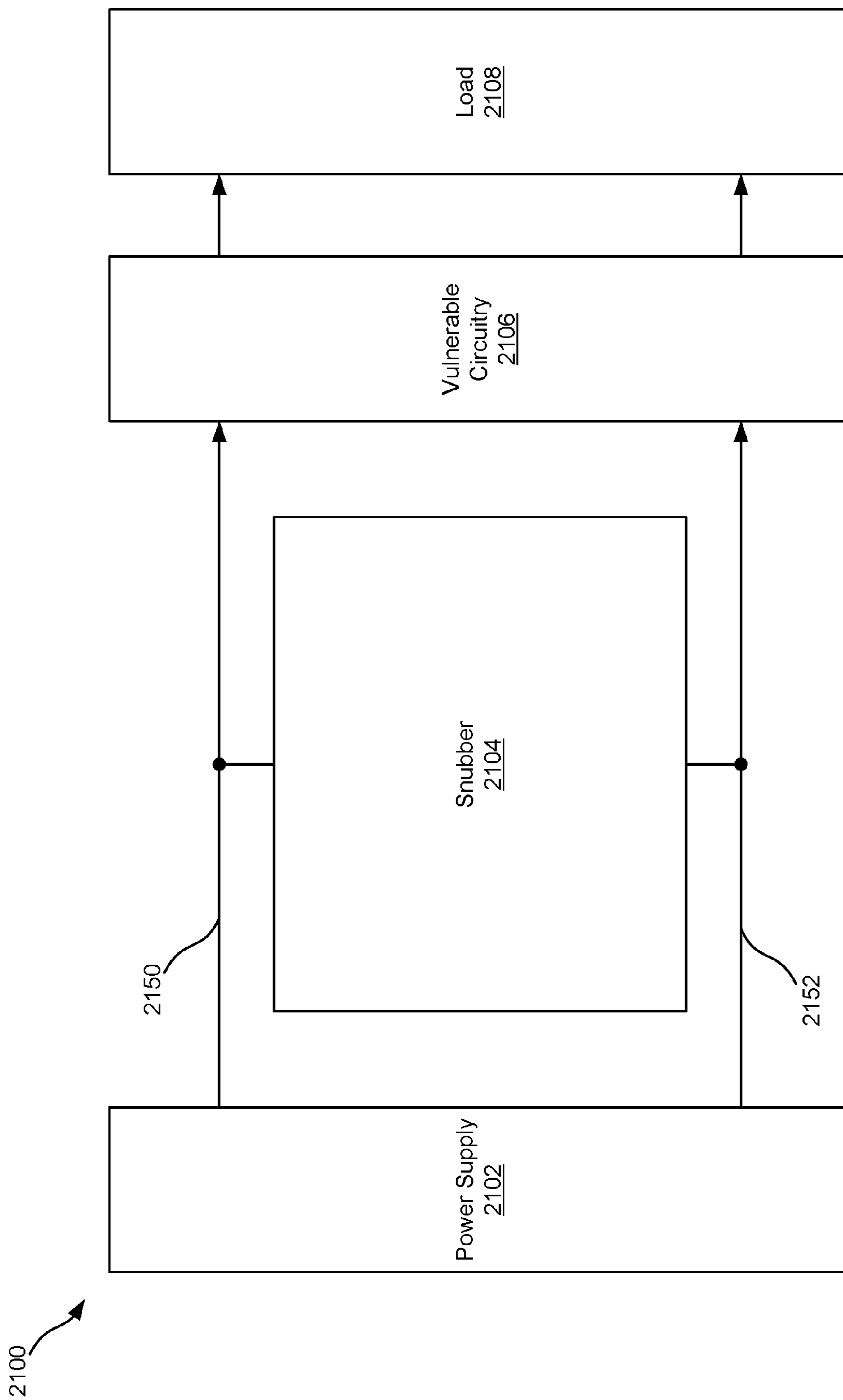

FIG. 23

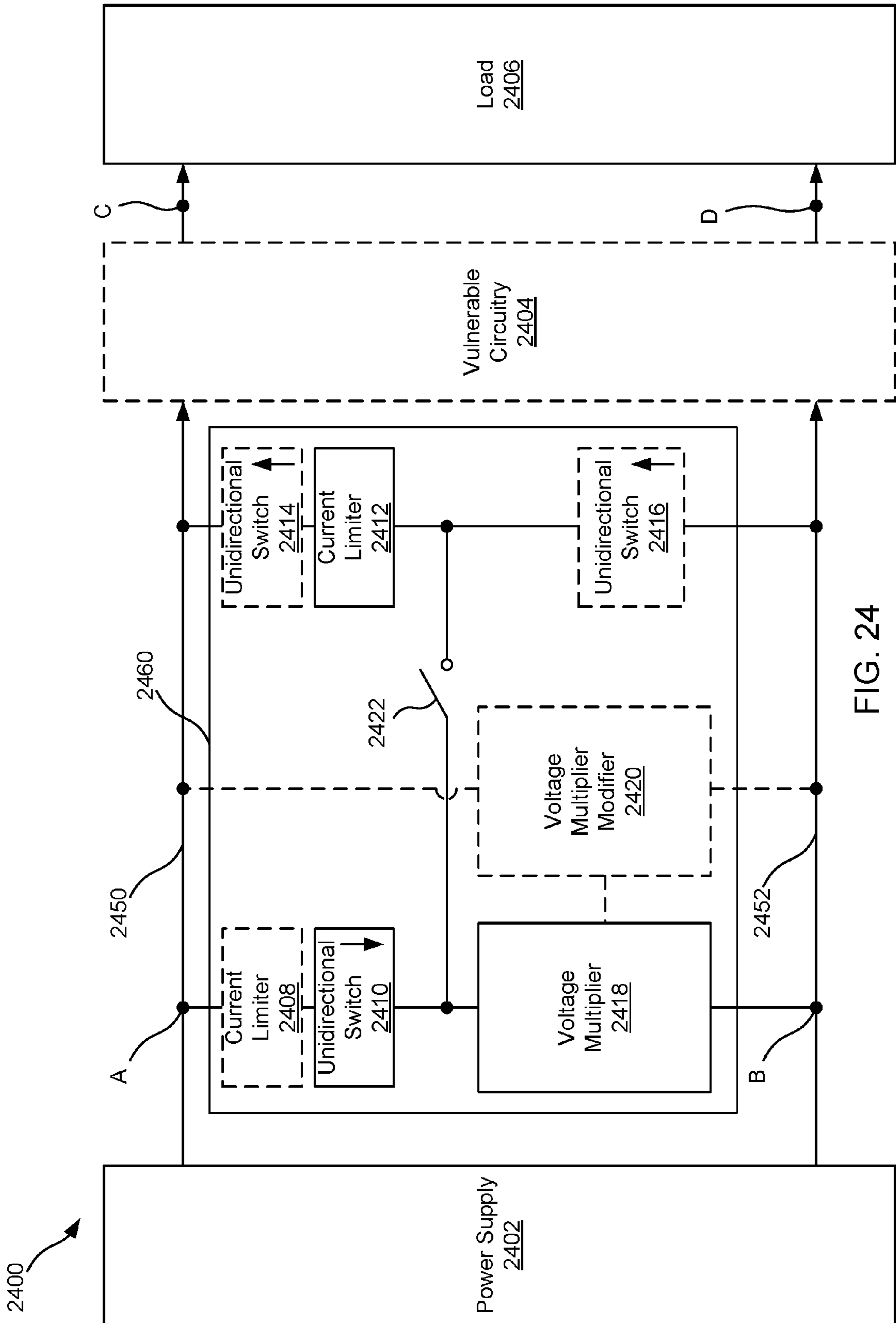

FIG. 24

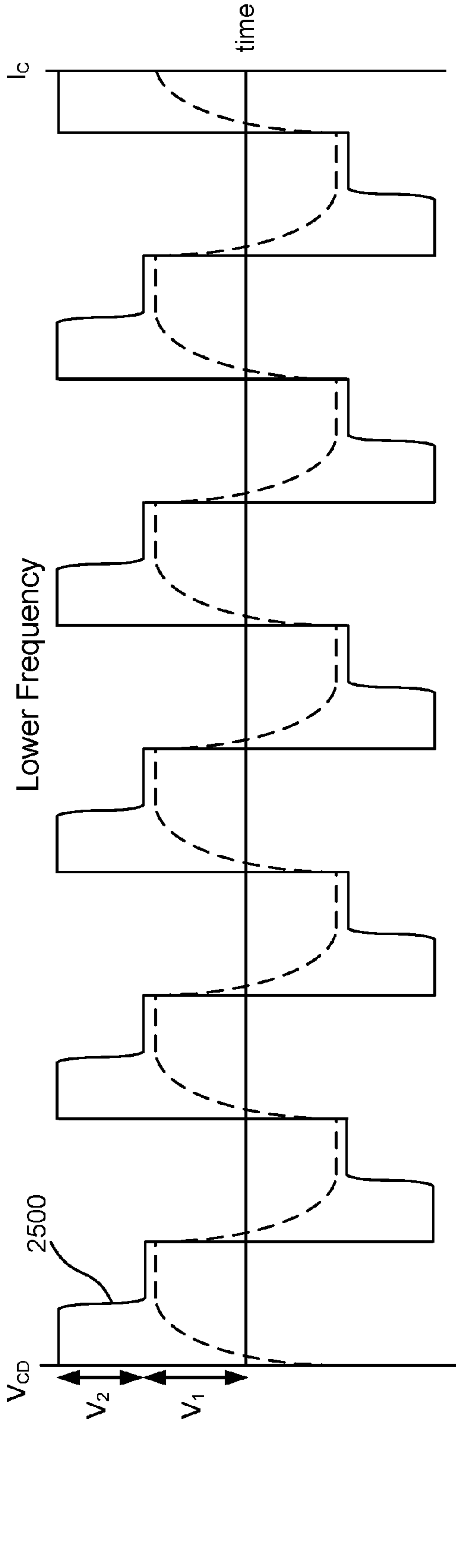

FIG. 25A

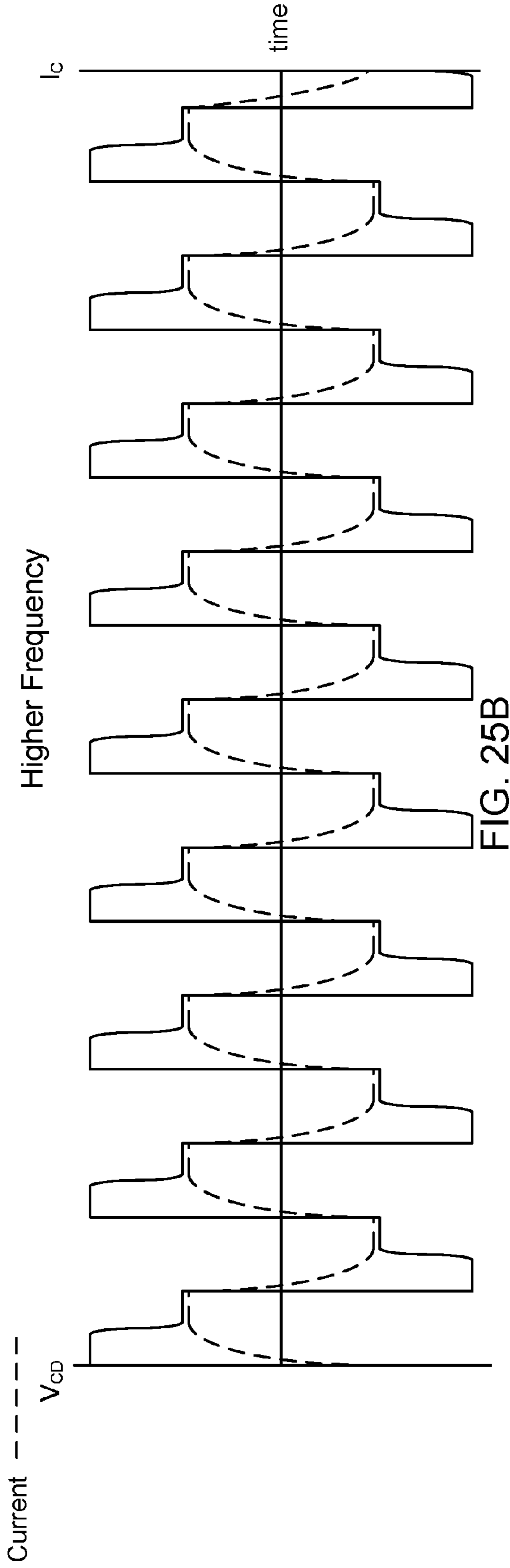

FIG. 25B

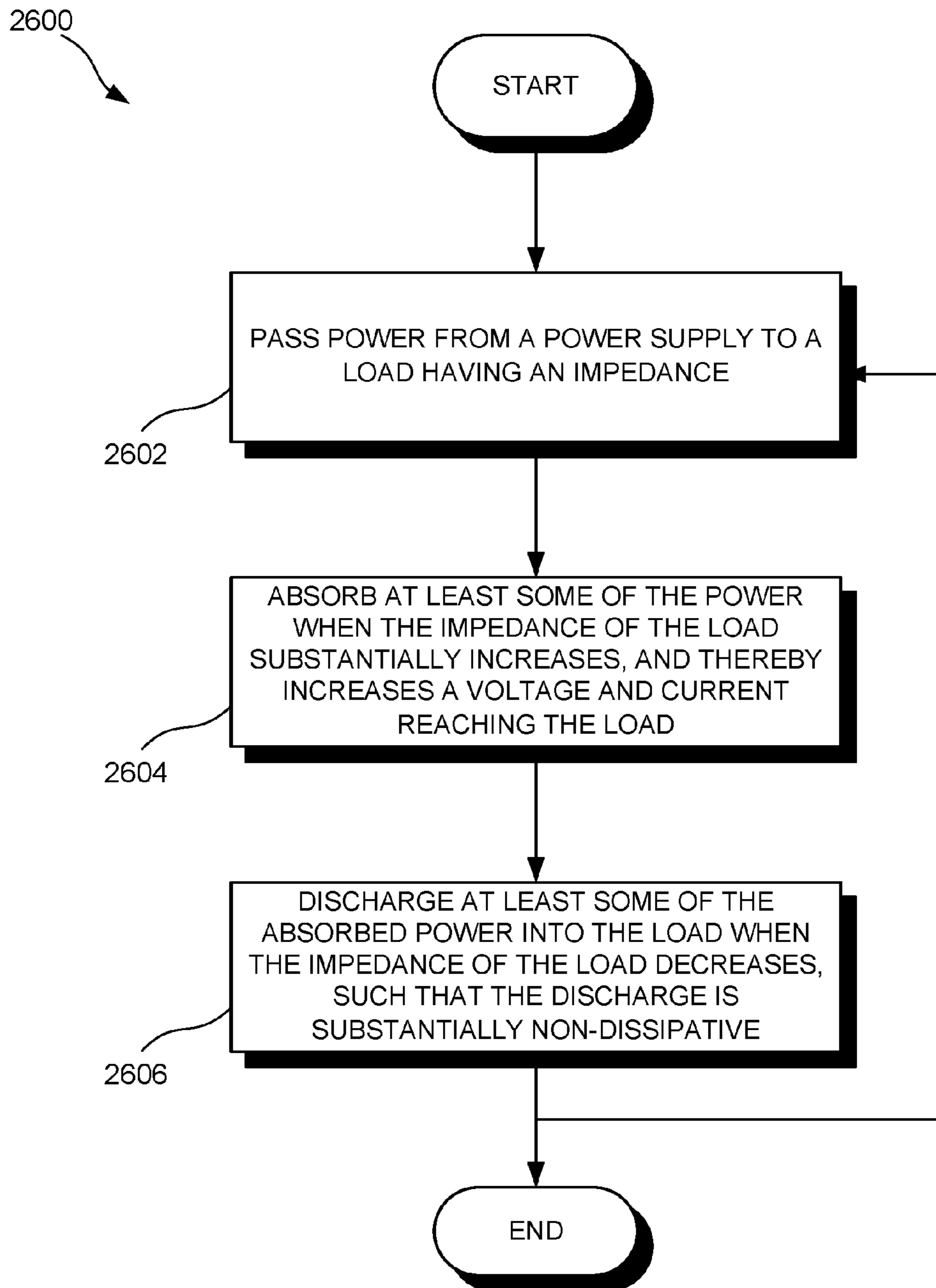

FIG. 26

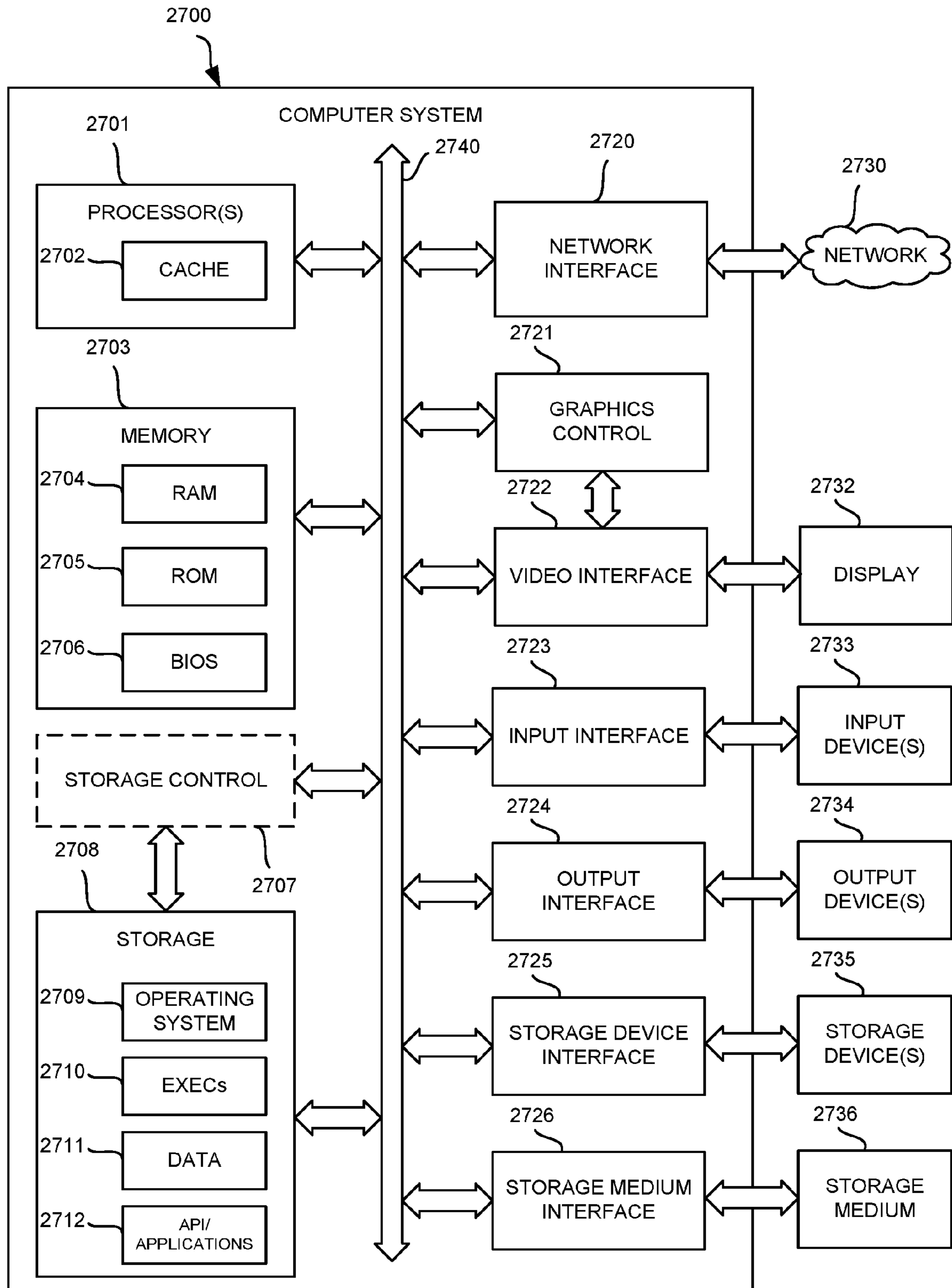

FIG. 27

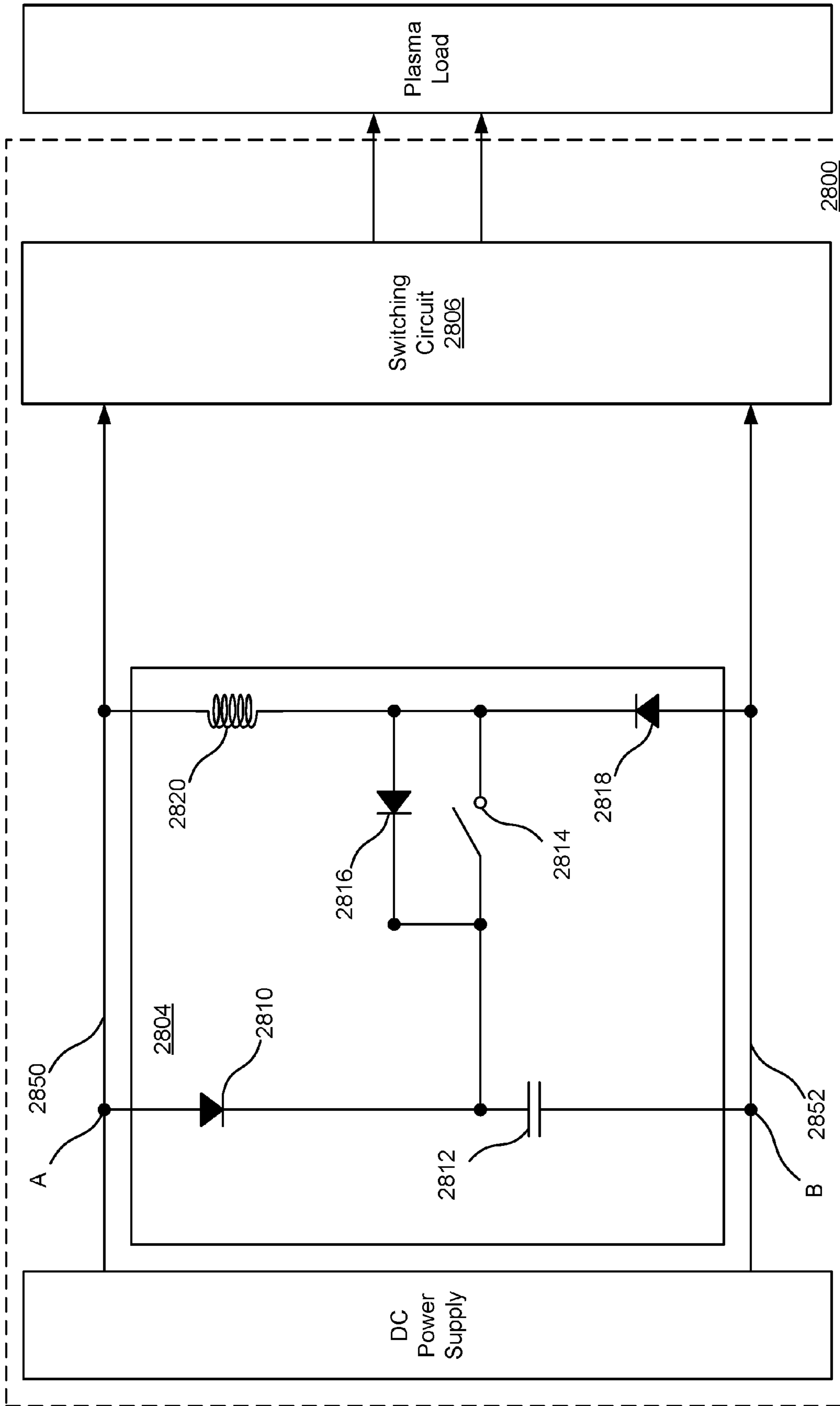

FIG. 28

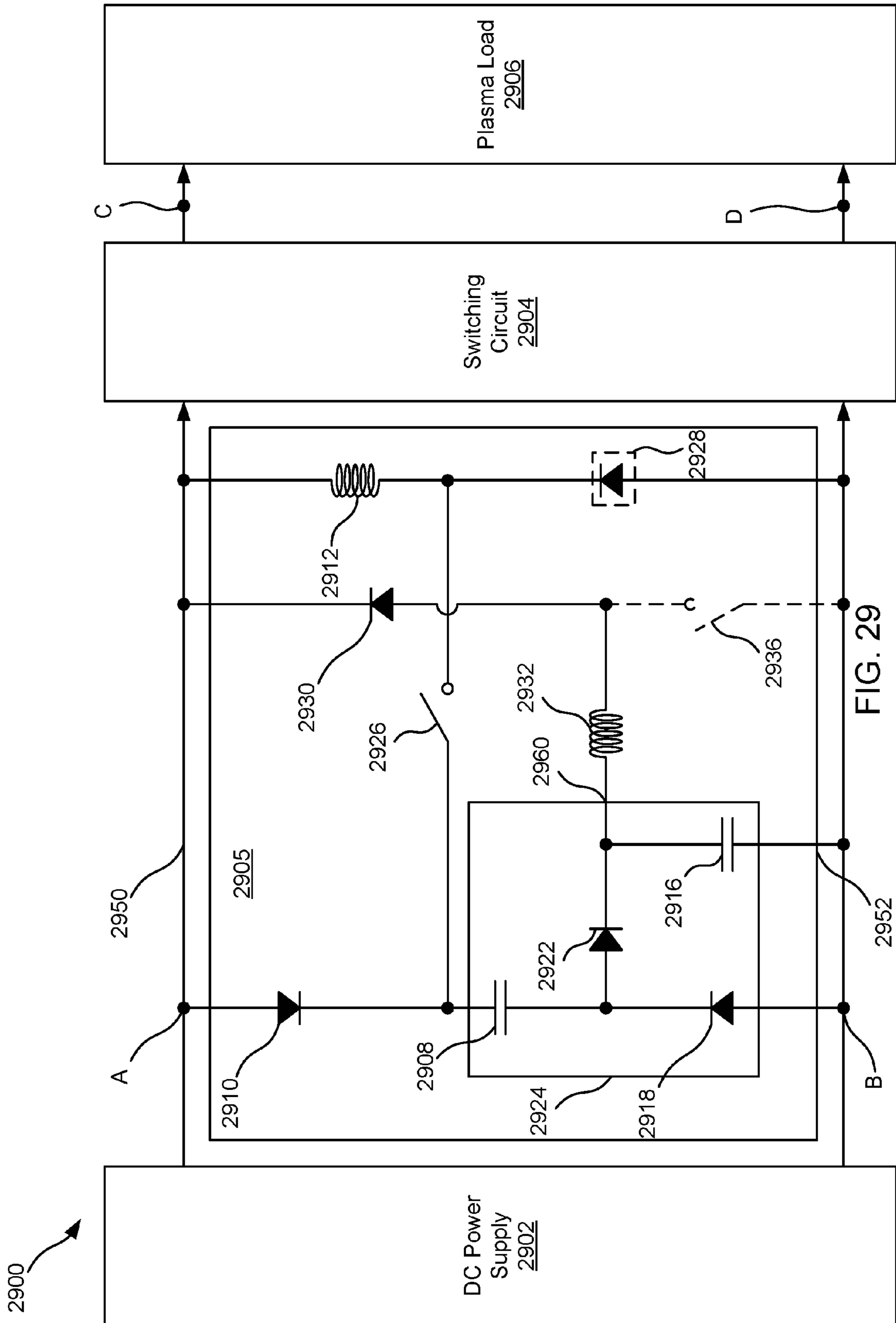

FIG. 29

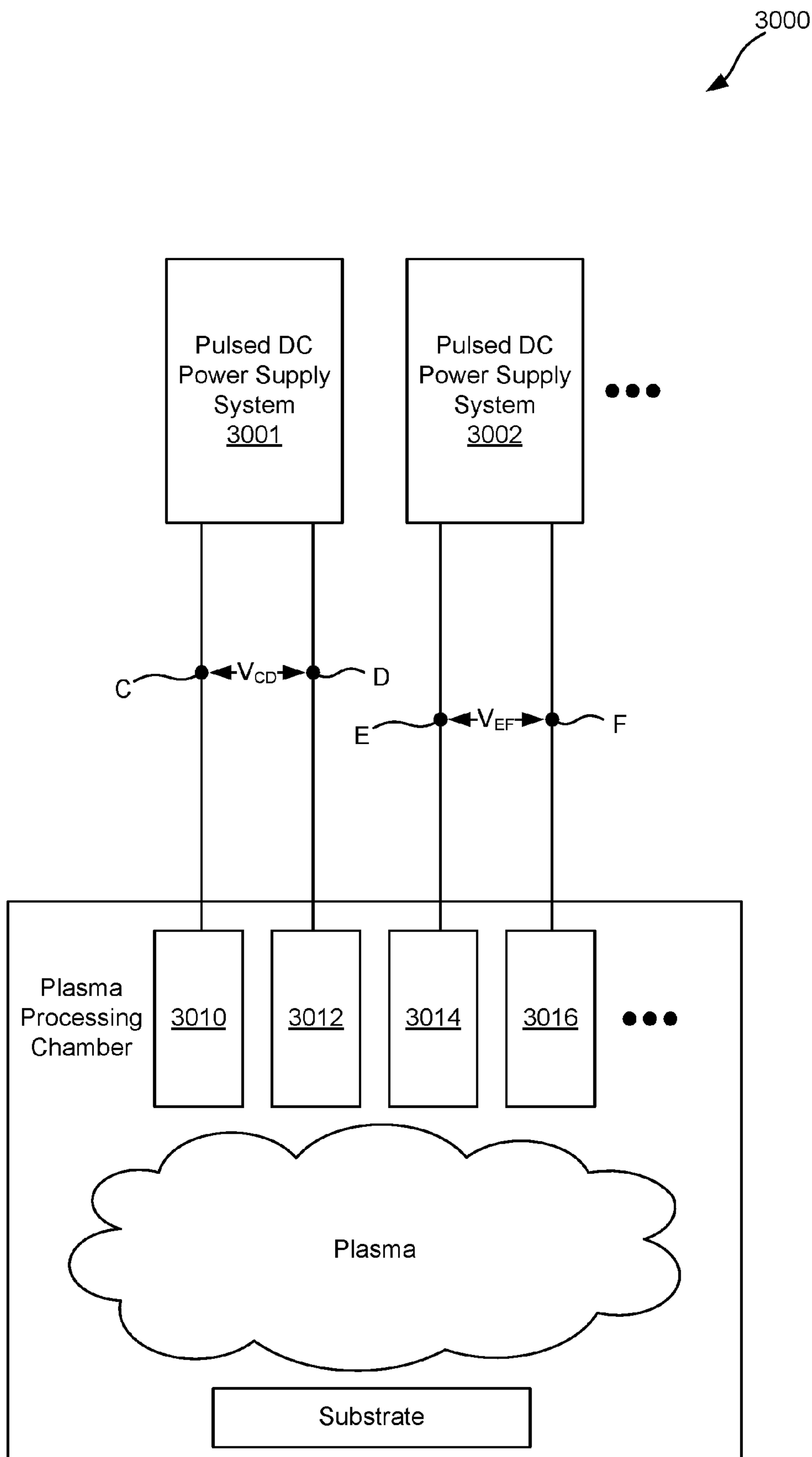

FIG. 30

**ADJUSTABLE NON-DISSIPATIVE VOLTAGE
BOOSTING SNUBBER NETWORK FOR
ACHIEVING LARGE BOOST VOLTAGES**

CLAIM OF PRIORITY UNDER 35 U.S.C. §120

The present Application for Patent is a Continuation of U.S. Patent Publication No. 2016/0071697 entitled "ADJUSTABLE NON-DISSIPATIVE VOLTAGE BOOSTING SNUBBER NETWORK FOR ACHIEVING LARGE BOOST VOLTAGES," filed Nov. 18, 2015, which is a Divisional of U.S. Pat. No. 9,224,579 entitled "ADJUSTABLE NON-DISSIPATIVE VOLTAGE BOOSTING SNUBBER NETWORK FOR ACHIEVING LARGE BOOST VOLTAGES," filed Feb. 20, 2014, which is a Continuation of U.S. Pat. No. 9,129,776 entitled "DIFFERING BOOST VOLTAGES APPLIED TO TWO OR MORE ANODELESS ELECTRODES FOR PLASMA PROCESSING," filed Apr. 22, 2013, which is a Continuation in Part of U.S. Pat. No. 9,226,380 entitled "ADJUSTABLE NON-DISSIPATIVE VOLTAGE BOOSTING SNUBBER NETWORK" filed Nov. 1, 2012. All applications are assigned to the assignee hereof and hereby expressly incorporated by reference herein.

FIELD OF THE DISCLOSURE

The present disclosure relates generally to power supplies. In particular, but not by way of limitation, the present disclosure relates to systems, methods and apparatuses for limiting voltage and current spikes in a power supply.

BACKGROUND

FIG. 1 illustrates one example of a typical power supply system **100** used for plasma processing. The power supply system **100** includes a DC power supply **102** providing DC power to a switching circuit **104** that converts the DC power into pulsed DC and provides the pulsed DC to a plasma load **106**. When switching, the potential between nodes C and D passes through a potential of zero, and the plasma can be extinguished or can dim to an extent that it becomes highly resistive and acts like an unfluxed inductor or an open circuit for a short time after this transition. Immediately after this transition, the DC power supply **102** continues to provide power to the switching circuit **104**, but most of that power can no longer be delivered to the plasma load **106**. Instead, the power predominantly passes through the switching circuit **104** potentially damaging the switching circuit **104**.

A snubber **108** can be used to mitigate damage to the switching circuit **104** by absorbing power from the DC power supply **102** during the period after the switching circuit **104** transitions through 0 V. However, existing snubbers are typically dissipative snubbers and/or dissipate significant power.

Additional challenges to known power supply systems include slow processing throughput and further inefficiencies from power dissipation. For instance, and as seen in FIG. 2A, while voltage between nodes C and D can switch with negligible ramp time, current ramps at a much slower pace thus providing an average power that is significantly lower than the power output from the DC power supply **102**. This leads to longer processing periods and decreased throughput, since many processes can only end when a predetermined total power has been delivered.

There is also a desire to increase DC pulse frequency provided to the plasma load **106** since this reduces arcing.

However, the above-noted problems become more acute at higher frequencies, as illustrated in FIG. 2B. Furthermore, since each pulse is shorter at higher frequency, the current at high frequency may end up larger (in a power-regulated system) than at lower frequency. Since power dissipation is proportional to I^2 , these larger currents lead to larger power losses. Additionally, switching losses, which are proportional to the current at the moment of switching, are accentuated at higher frequencies since switching current is larger.

SUMMARY OF THE DISCLOSURE

Exemplary embodiments of the present invention that are shown in the drawings are summarized below. These and other embodiments are more fully described in the Detailed Description section. It is to be understood, however, that there is no intention to limit the invention to the forms described in this Summary of the Invention or in the Detailed Description. One skilled in the art can recognize that there are numerous modifications, equivalents and alternative constructions that fall within the spirit and scope of the invention as expressed in the claims.

Some embodiments of the disclosure may be characterized as a power system comprising a DC power supply, a switching circuit, and a snubber circuit. The DC power supply can supply DC power to first and second rails having a voltage between the first and second rails. The switching circuit can receive the DC power via the first and second rails and converting the DC power to a pulsed DC voltage, the pulsed DC voltage configured for application to a plasma load. The snubber circuit can be coupled to the first and second rails such that the voltage between the first and second rails falls across the snubber circuit. Furthermore, the snubber circuit can comprise a first unidirectional switch, a voltage multiplier, an electrical node, and a current limiter. The first unidirectional switch can be configured to allow current to pass from the first rail. The voltage multiplier can be coupled between the first unidirectional switch and the second rail. The voltage multiplier can be configured to absorb and store energy from the DC power supply via the first unidirectional switch when an impedance seen by the switching circuit increases. It can also be configured to boost the voltage between the first and second rails by virtue of absorbing and storing the energy from the DC power supply. It can further be configured to then apply at least a portion of the stored energy to the switching circuit when the impedance seen by the switching circuit decreases and thereby decrease the voltage between the first and second rails. The electrical node can be arranged between the first unidirectional switch and the voltage multiplier. The current limiter can be coupled between the electrical node and the first rail and can limit rises in current that the voltage multiplier discharges to the switching circuit.

Other embodiments of the disclosure may also be characterized as a snubber circuit comprising a voltage multiplier, a first unidirectional switch, and a first current-limiter. The voltage multiplier can be coupled between a first power rail and a second power rail and it can absorb and store energy from the first rail and consequently boost a voltage between the first and second rail, and then discharge at least some of the energy and consequently reduce the voltage between the first and second rail. The first unidirectional switch can allow current to pass from the first power rail to the voltage multiplier, but can block current attempting to pass back to the first power rail through the first unidirectional switch. The first current-limiter can be coupled between the first power rail and the voltage multiplier. The

first current-limiter can provide a low-resistance current path from the voltage multiplier to the first power rail and can limit a rate of change of current that the voltage multiplier discharges to the first power rail.

Other embodiments of the disclosure can be characterized as a method comprising passing power from a power supply to a load having an impedance. The method can also include absorbing at least some of the power when the impedance of the load substantially increases and thereby increasing a voltage and a current reaching the load. The method finally includes discharging at least some of the absorbed power into the load when the impedance of the load decreases, such that the discharge is substantially non-dissipative.

BRIEF DESCRIPTION OF THE DRAWINGS

Various objects and advantages and a more complete understanding of the present invention are apparent and more readily appreciated by referring to the following detailed description and to the appended claims when taken in conjunction with the accompanying drawings:

FIG. 1 illustrates one example of a typical power supply system used for plasma processing;

FIGS. 2A and 2B illustrate plots of voltage and current for a traditional power supply system;

FIG. 3 illustrates a power supply system including a DC power supply, a switching circuit, a plasma load, and an embodiment of a non-dissipative snubber circuit;

FIG. 4 illustrates a power supply system including a DC power supply, a switching circuit, a plasma load, and another embodiment of a dissipative snubber circuit;

FIG. 5 illustrates a power supply system including a DC power supply, a switching circuit, a plasma load, and yet another embodiment of a non-dissipative snubber circuit;

FIG. 6 illustrates a power supply system including a DC power supply, a switching circuit, a plasma load, and yet another embodiment of a non-dissipative snubber circuit;

FIG. 7 illustrates a power supply system including a DC power supply, a switching circuit, a plasma load, and yet another embodiment of a non-dissipative snubber circuit;

FIGS. 8A and 8B illustrate plots of voltage and current for a power supply system according to one embodiment of this disclosure;

FIG. 9 illustrates an embodiment of a power supply system showing details of a voltage multiplier;

FIG. 10 illustrates an embodiment where the voltage multiplier of the snubber is a voltage tripler;

FIG. 11 illustrates a power supply system including a DC power supply, a switching circuit, a plasma load, yet another embodiment of a snubber circuit, and a voltage multiplier modifier;

FIG. 12 illustrates a plot of voltage and current for a power supply system according to one embodiment of this disclosure;

FIG. 13 illustrates a power supply system showing details of one embodiment of a voltage multiplier modifier;

FIG. 14 illustrates a power supply system showing details of one embodiment of a voltage multiplier and of a voltage multiplier modifier;

FIG. 15 illustrates a power supply system including a DC power supply providing power to a switching circuit, which then provides pulsed DC power to a plasma load;

FIG. 16 illustrates a power supply system including a DC power supply providing power to a switching circuit, which then provides pulsed DC power to a plasma load;

FIG. 17 illustrates a power supply system including a DC power supply providing power to a switching circuit, which then provides pulsed DC power to a plasma load;

FIG. 18 illustrates the power supply system of FIG. 14 just after a 0 V transition of the switching circuit;

FIG. 19 illustrates the power supply system of FIG. 14 during a falling edge of a voltage boost from the snubber;

FIG. 20 illustrates the current paths and diode biases in the power supply system of FIG. 14 during a single arc event;

FIG. 21 illustrates the current paths and diode biases in the power supply system of FIG. 14 during a succession of high-frequency arcs;

FIG. 22 illustrates another embodiment of a power supply system;

FIG. 23 illustrates yet another power supply system;

FIG. 24 illustrates yet a further power supply system;

FIGS. 25A and 25B illustrate plots of voltage and current for a power supply system according to one embodiment of this disclosure;

FIG. 26 illustrates a method of controlling power in a power supply system; and

FIG. 27 shows a diagrammatic representation of one embodiment of a machine in the exemplary form of a computer system;

FIG. 28 illustrates an alternative topology for a voltage-boosting circuit;

FIG. 29 illustrates another embodiment of a voltage boosting circuit having snubber functionality; and

FIG. 30 illustrates an embodiment of a power supply system including two or more pulsed DC power supply systems providing pulsed DC power to four or more anode-less electrodes in a plasma processing chamber.

DETAILED DESCRIPTION

The present disclosure relates generally to power supply systems. More specifically, but without limitation, the present disclosure relates to a non-dissipative snubber for use in a power supply system.

The word “exemplary” is used herein to mean “serving as an example, instance, or illustration.” Any embodiment described herein as “exemplary” is not necessarily to be construed as preferred or advantageous over other embodiments.

For the purposes of this disclosure, a current limiter is any device or circuit that limits a current that can pass through the current limiter or that limits a rate at which current passing through the current limiter can rise or fall. In some embodiments, a current limiter can limit both the rate of increase and an upper bound of the current passing through the current limiter. An inductor, resistor, JFET, MOSFET, and IGBT are all examples of current-limiting elements since each are able to limit the rate of change of and amount of current.

For the purposes of this disclosure, a switch includes any circuit or device that stops the passage of current when in an off or open state. For instance, transistors (e.g., MOSFET, BJT, IGBT) can be a switch, and in some cases, where a current limiter is operated so as to reduce current to 0 A, a current limiter can be a switch.

For the purposes of this disclosure, a unidirectional switch includes any device or circuit that only passes current in a single direction. For instance, both a diode and a transistor can be considered a unidirectional switch, depending on operation.

5

The challenges noted in the background can be dealt with via use of a non-dissipative snubber 2460 as illustrated in FIG. 24, comprising a first unidirectional switch 2410, a voltage multiplier 2418, and a first current limiter 2412. The snubber 2460 can be arranged between a first power rail 2450 and a second power rail 2452, wherein the power rails 2450 and 2452 transfer power from a power supply 2402 to a load 2406 (e.g., a plasma of a plasma processing chamber), and optionally transfer said power through vulnerable circuitry 2404 (e.g., a switching circuit). The first unidirectional switch 2410 can be arranged between a first power rail 2450 and the voltage multiplier 2418 and allows current to pass from the first power rail 2450 to the voltage multiplier 2418 (optionally through a current limiter 2408), but prevents current from traveling a reverse path through the unidirectional switch 2410. The first current limiter 2412 can couple the voltage multiplier 2418 to the first power rail 2450 in parallel to the unidirectional switch 2410 and provides a low-loss current path from the voltage multiplier 2418 to the first power rail 2450. The snubber 2460 may further include a switch 2422 between the voltage multiplier 2418 and the first current limiter 2412, wherein the switch 2422 remains closed during most operations, but is opened when a current in the current limiter 2412 reaches a threshold, and then closes when the current in the current limiter 2412 falls below the threshold.

One advantage of the snubber 2460 is its ability to non-dissipatively absorb energy from the power supply 2402 when an impedance of the load 2406 increases, or substantially increases. For instance, where the load 2406 is a plasma, and the plasma dims or is extinguished, the plasma impedance increases substantially. When the load 2406 impedance increases substantially, the power supply 2402 continues to deliver the same power, and this power would dissipate largely in the vulnerable circuitry 2404. However, the snubber 2460, and in particular, the voltage multiplier 2418, absorbs a large portion of this energy, thus protecting the vulnerable circuitry 2404.

Another advantage of the snubber 2460 is to avoid rapid discharges of the stored energy in the voltage multiplier 2418 when the load 2406 impedance suddenly drops. For instance, where the load 2406 is a plasma, and an arc in the plasma occurs, the arc creates a low impedance current path for the energy in the voltage multiplier 2418. However, the current limiter 2412 prevents rapid discharge of the voltage multiplier 2418. In the case of plasma arcs, this aspect helps prevent the snubber 2460 from exacerbating arcs.

A third advantage of the snubber 2460 is an ability to boost a voltage that the power supply 2402 provides to the load 2406, and consequently boosts a current ramp rate provided to the load 2406. When the voltage multiplier 2418 absorbs energy from the power supply 2402, a voltage across the voltage multiplier 2418 can be raised to some multiple of a voltage between nodes A and B, V_{AB} , generated by the power supply 2402. In this way, the voltage multiplier 2418 can boost a voltage, and thus a current ramp rate, provided to the load 2406 after the load 2406 impedance rises. Where there is a desire to control or limit the multiplying effect of the voltage multiplier 2418, (e.g., where one or more devices have a voltage threshold that can be exceeded if the voltage multiplier's full effect is enabled) an optional voltage multiplier modifier 2420 may be utilized (see FIGS. 11-14). The voltage multiplier modifier acts as a 'control knob' over the voltage boost provided by the voltage multiplier 2418.

The power supply 2402 can be embodied by a current source or other current-regulating power supply. In one

6

embodiment, the power supply 2402 can be any power supply having an output current that is limited to slow changes in current. For instance, the power supply 2402 can be any power supply having an inductive output behavior. The power supply 2402 may be able to raise its compliance voltage, and hence the voltage V_{AB} . The ability to raise the compliance voltage, and hence, V_{AB} , can further enable turn-on of the unidirectional switch 2410.

The snubber 2460 has particular application to pulsed DC power systems providing pulsed DC power to a plasma load during plasma processing. For instance, and as illustrated in FIG. 7, a non-dissipative snubber can be arranged between a DC power supply 702 (e.g., power supply 2402) and a switching circuit 704 (e.g., vulnerable circuitry 2404) providing pulsed DC voltage to a plasma load 706 (e.g., load 2406). In this application, the non-dissipative snubber absorbs power from the DC power supply 702 when the plasma load 706 impedance rises such that power would otherwise damage the switching circuit 704 (e.g., immediately after the switching circuit voltage transitions through 0 V), avoids excessive current discharge during arc events in the plasma, and increases a ramp rate of current provided to the plasma load 706 during each voltage pulse. These advantages can be especially beneficial for high frequency pulsing and high power applications.

The non-dissipative snubber includes a voltage multiplier 724 that temporarily boosts a voltage V_{AB} and thus a current provided to the switching circuit 704 in order to increase an average power delivered to the plasma load 706, thereby increasing throughput, and decreasing losses from excessive currents. The non-dissipative snubber can also include an inductor 712 to prevent the voltage multiplier 724 from rapidly discharging stored energy into the switching circuit 704 and the plasma load 706 when the plasma load 706 drops (e.g., during an arc). The snubber circuit may further include a switch 726 between the voltage multiplier 724 and the inductor 712 to help stop runaway current ramping in the inductor 712 caused by high-frequency multiple arc events in the plasma (e.g., rapid succession of arcs). Various diodes 710, 714, and 728 and capacitors can be interleaved with the above-noted components in order to control the direction of currents in the non-dissipative snubber and various capacitors can be used to store energy.

In one embodiment, a capacitor can replace the voltage multiplier 724 (see FIG. 6). In one embodiment, the voltage multiplier 724 can be a voltage doubler (see FIG. 9), a voltage tripler (see FIG. 10), or any other multiplier having an integer or fractional multiplying effect.

Before delving deeper into FIGS. 7 and 24, a discussion of the development of these circuits and power systems may be helpful. FIG. 3 illustrates a power supply system 300 including a DC power supply 302, a switching circuit 304, a plasma load 306, and an embodiment of a non-dissipative snubber circuit. The DC power supply 302 provides DC power to the switching circuit 304 (e.g., a half-bridge switching circuit) which converts the DC power to pulsed DC that is then provided to the plasma load 306. In order to prevent damage to the switching circuit 304 during switching, when the plasma load 306 appears as a capacitor or open circuit, a snubber circuit including a capacitor 308 coupled between a first rail 350 (positive rail) and a second rail 352 (negative rail) can be implemented. While the capacitor 308 can limit current and/or voltage spikes in the switching circuit 304, it unfortunately also quickly discharges stored energy into arcs in the plasma, thus exacerbating such events.

FIG. 4 illustrates a power supply system 400 including a DC power supply 402, a switching circuit 404, a plasma load 406, and another embodiment of a dissipative snubber circuit. In this embodiment the snubber circuit includes a diode 410, a capacitor 408, and a resistor 412. During switching circuit 404 switching, when the plasma load 406 appears as a capacitor or open circuit, a majority of power from the DC power supply 402 passes through the diode 410 and charges the capacitor 408. The capacitor 408 can discharge its energy through the resistor 412 to the switching circuit 404 in the plasma load 406 when the plasma load 406 impedance returns to typical levels. Unlike the snubber illustrated in FIG. 3, the snubber of FIG. 4 limits the current that the capacitor 408 discharges to the first rail 450 via the resistor 412, whose resistance can be selected to meet a maximum current threshold. However, power is dissipated as current passes through the resistor 412, and thus this design is merely a dissipative snubber.

FIG. 5 illustrates a power supply system 500 including a DC power supply 502, a switching circuit 504, a plasma load 506, and yet another embodiment of a non-dissipative snubber circuit. However this design replaces the resistor 412 in FIG. 4 with an inductor 512, thus enabling the capacitor 508 to discharge stored energy in a non-dissipative fashion. In this case, power from the DC power supply 502 can pass through the diode 510 (or any unidirectional switch) and charge the capacitor 508 (or any capacitive circuit or device, such as a capacitor) when the switching circuit 504's switching of the plasma load 506 appears as a capacitor or an open circuit. Energy stored in the capacitor 508 can be discharged through the inductor 512 (or any inductive circuit or device), the switching circuit 504, and to the plasma load 506 without the losses incurred by passing said energy through a resistor. At the same time, like the resistor 412, the inductor 512 limits the rate of increase in current thus preventing the capacitor 508 from dangerously discharging its energy during arcing events.

In an optional embodiment the snubber can include a diode 514 (or any unidirectional switch) arranged between the inductor and the first rail 550 that prevents current from charging the capacitor 508 through the inductor 512. This diode 514 may be required since the inductor 512, rather than the diode 510, is the path of least resistance from the first rail 550 to the capacitor 508. The inductor-capacitor (512, 508) combination can also lead to ringing, and thus the optional diode 514 helps to alleviate this ringing.

However, since the inductor 512 and diode 510 (and optionally the diode 514) are arranged in a near-lossless current loop 511, current in the inductor 512 continues to flow with little or no dissipation. Every time an arc occurs, the capacitor 508 discharges some energy in the form of current through the inductor 512, and then recharges after the arc. The added current builds upon the already looping current, and if the rate of arcing is high enough, then the current in the inductor 512 can step wise build in a runaway current ramp until the current in this loop 511 damages or destroys either or both of the diodes 510 and 514.

In some embodiments, a bank of capacitors can replace the capacitor 508 such that smaller and less expensive capacitors can be used to achieve a large capacitance.

FIG. 6 illustrates a power supply system 600 including a DC power supply 602, a switching circuit 604, a plasma load 606, and yet another embodiment of a non-dissipative snubber circuit. In this case, a switch 626 can be arranged between an electrical node 609 (between a diode 610 and a capacitor 608) and an inductor 612. The switch 626 can remain closed during normal processing, but be opened

during arc events in order to cut the near-lossless current loop formed by the inductor 612 and the diode 610 (and optionally a diode 614). Thus, when high-frequency arc events occur, a current in the inductor 612 may stepwise rise as a result of each successive discharge from the capacitor 608. When the current reaches a threshold, the switch 626 opens, and the current passes into the capacitor 608 via diode 610 thus providing a current path for the inductor to discharge through until the energy stored in the inductor's magnetic field falls and the current in the inductor 612 drops below the threshold. This prevents the runaway current ramp in the inductor 612 that was described with reference to FIG. 5.

Optionally, the snubber can include a diode 628 (or other unidirectional switch) arranged between an electrical node 613 and the second rail 652. The electrical node 613 is arranged between the switch 626 and the inductor 612. The optional diode 628 is forward biased when the switch 626 opens, thus providing a current path from the second power rail 652 to the inductor 612 and thus enabling the inductor 612 to continue to draw current when the switch 626 opens. This avoids voltage spikes across the inductor 612. At the same time, the diode 628 is reverse biased when the switch 626 is closed, thus preventing current from passing to the second power rail 652 after passing through the switch 626.

In some embodiments, a bank of capacitors can replace the capacitor 608 such that smaller and less expensive capacitors can be used to achieve a large capacitance.

FIG. 7 illustrates a power supply system 700 including a DC power supply 702, a switching circuit 704, a plasma load 706, and yet another embodiment of a non-dissipative snubber circuit. Here, a voltage multiplier 724 replaces the capacitor seen in earlier snubber embodiments. The voltage multiplier 724 is designed to improve the efficiency of the system 700, while still enabling the snubber to absorb power from the DC power supply 702 and thus protect the switching circuit 704.

In particular, and recalling FIGS. 2A and 2B, pulsed DC power systems often suffer from slow current ramp rates during each pulse. The voltage multiplier 724 absorbs power from the DC power supply 702 after the switching circuit 704 voltage switches, but also boosts process voltage, V_1 , to a boosted voltage, V_1+V_2 , for a first portion 802 of each pulse so that current ramps faster as illustrated in FIG. 8A. For instance, the DC power supply 702 provides sufficient power to enable the process voltage V_1 , but the voltage multiplier 724 boosts this voltage by V_2 during the first portion 802 of each pulse.

This voltage boost is actually a byproduct of the snubber circuit absorbing power from the DC power supply 702 immediately after 0 V transitions of the switching circuit 704. When the switching voltage reaches 0 V, the plasma density drops substantially and the plasma acts more like an open circuit or an unfluxed inductor than as a low resistance current path. The DC power supply 702 is current or power regulated and thus continues to drive the same current level. The snubber circuit absorbs this power, which otherwise would be directed into the switching circuit 704 and potentially damage that circuit.

As current passes into the voltage multiplier 724, energy is stored within the voltage multiplier 724 and accumulates along with a voltage that is increasingly larger than the process voltage V_2 until the current in the plasma has ramped sufficiently to raise the plasma density back to a level where power can again be largely provided to the plasma load 706 rather than to the snubber. This time is long enough that the voltage across the voltage multiplier 724

builds to greater than the process voltage, V_1 , and thus for a first portion **802** of each DC pulse, there is a voltage boost of V_2 as seen in FIG. **8A**.

This increased voltage causes the current to ramp faster than seen in the art (e.g., FIG. **2A**). As a result, the current flattens out sooner in each pulse meaning that greater average power is delivered and thus less time is required for a given process. The increased current ramp rate also means that current does not rise as high as it would given a slower ramp rate, which results in less overall losses (proportional to I^2) and less switching losses (proportional to I at the moment of switching). These improvements in efficiency are especially noticeable at higher frequencies (see FIG. **8B** and compare to FIG. **2B**).

It should be noted that FIG. **8A** is a simplification of the voltage and current waveforms, and in practice the vertical rises and falls may have non-infinite slopes caused by capacitive and inductive effects.

If the voltage between the first rail **750** and the second rail **752** falls below approximately the process voltage, V_1 , then the voltage multiplier **724** can partially discharge and supplement the current provided from the DC power supply **702** at approximately the process voltage, V_1 .

During arcs, the voltage multiplier **724** can also discharge some of its energy through the closed switch **726** and the inductor **712**. A near-lossless current loop **711** may then be established through the inductor **712**, the diode **710**, and the closed switch **726** (and optionally the diode **714**) until the switch **726** is opened, thus forcing the current to recharge the voltage multiplier **724**.

In some embodiments, $V_2=V_1$ (e.g., the voltage multiplier **724** is a voltage doubler). However, in other embodiments, V_2 can be less than or greater than the process voltage, V_1 . In some embodiments, V_2 can even be variable (see FIGS. **11-14**).

In some embodiments, the first diode **710** can be arranged in series with a current limiter such as an inductor (not illustrated) so as to limit not only the direction of current into the voltage multiplier **724**, but to also limit the amount and rate of change of current entering the voltage multiplier **724**. Such a current limiter may be implemented to prevent current overload in the voltage multiplier **724**. In embodiments, where two or more of the herein disclosed snubbers are arranged in parallel, the current limiter may limit the current entering each of the snubbers so that voltage can remain at a reasonable level while still sending current to each of the two or more snubbers.

In such an embodiment, the current limiter in series with the first diode **710** can be selected so that current is able to rapidly enter and charge the voltage multiplier **724**, while the inductor **712** can be selected so that the voltage multiplier **724** discharges at a lower current. This can lead to a rapid boosting of voltage to V_1+V_2 at the start of each DC pulse (see the first portion **802** of FIGS. **8A** and **8B**) while the voltage multiplier **724** supplements the DC power supply **702** current at V_1 over a longer second portion of each DC pulse.

In one embodiment, the first and second rails **750** and **752** are floating, such that neither is referenced to ground.

The diode **714** can be optional where the LC time constant is long. A "long" LC time constant is one where the inductor **712** current is prevented from reversing direction. In particular, the inductor **712** is sinusoidal without the optional diode **714**, and so the LC time constant is equal to the inverse resonant frequency of the inductor **712** and the capacitor of the voltage multiplier **724** and preferably an order of magnitude greater than the inverse switching fre-

quency of the switching circuit **704**. The LC time constant can be calculated from the inductance of the inductor **712** and any capacitance of the voltage multiplier **724**.

The switching circuit **704** takes either DC voltage or constant power from the DC power supply **702** and generates pulsed DC power. Two non-limiting examples of the switching circuit **704** are an H-bridge (half or full bridge) or a double-pole double-throw switch network. In one embodiment, the switching circuit **704** can include two or more half or full bridge H-bridge circuits coupled in parallel (e.g., one pair of H-bridge outputs is parallel to the next pair of H-bridge outputs).

The plasma load **706** can be part of a plasma processing chamber, such as those used in plasma processing (e.g., sputtering or etching). Power can be provided to the plasma load **706** via one or more electrodes such as those in dual-magnetron sputtering (one or more magnetrons can also be used).

FIG. **9** illustrates an embodiment of a power supply system **900** showing details of a voltage multiplier **924**. The voltage multiplier **924** includes a first capacitor **908** (or a capacitor bank or any capacitive element or system), a second capacitor **916**, a first diode **918**, a second diode **922**, and a third diode **920**. The first and second capacitors **908** and **916** can be charged in series when the second diode **922** is forward biased. The first and second capacitors **908** and **916** can then discharge in parallel when the first and third diodes **918** and **920** are forward biased, and the second diode **922** is reverse biased.

FIG. **10** illustrates an embodiment where the voltage multiplier of the snubber is a voltage tripler. The voltage multiplier **1024** includes a first capacitor **1002**, a second capacitor **1004**, and a third capacitor **1006**. The voltage multiplier **1024** further includes a first diode **1008**, a second diode **1010**, a third diode **1012**, a fourth diode **1014**, and a fifth diode **1016**. Each of the capacitors **1002**, **1004**, **1006** can be charged to near or greater than the process voltage, and therefore when all three are charged, a voltage drop across all three is around three times the process voltage. Thus, the voltage multiplier **1024** is able to boost the voltage across the first and second rails **1050**, **1052** by a factor of about three and can therefore be referred to as a voltage tripler.

In some embodiments, a bank of capacitors can replace the capacitors **1002**, **1004**, and **1006** such that smaller and less expensive capacitors can be used to achieve a large capacitance.

FIG. **11** illustrates a power supply system **1100** including a DC power supply **1102**, a switching circuit **1104**, a plasma load **1106**, yet another embodiment of a voltage multiplier **1124**, and a voltage multiplier modifier **1130**. Here, the snubber sees the addition of a voltage multiplier modifier **1130** coupled between a first and second rail **1150**, **1152**, and having an electrical connection to the voltage multiplier **1124**. The voltage multiplier modifier **1130** can control the effect of the voltage multiplier **1124** on the voltage, V_{AB} , between the rails **1150** and **1152**. In this way the boost voltage V_2 (see FIG. **12**) can be tailored to a desired amplitude that is less than the maximum boost that the voltage multiplier **1124** is capable of. Furthermore, the voltage V_2 can be varied in time. This embodiment has particular application where the voltage multiplier **1124** has a fixed multiplying effect (e.g., a voltage doubler or a voltage tripler).

One application of such control is illustrated in FIG. **12**, where a voltage threshold **1202** shows a threshold above which circuitry in the power supply system **1100** can be

11

damaged. As such the voltage multiplier modifier **1130** can be used to lower V_2 so that the total voltage (V_2+V_1) of the first portion **802** of the pulses remains below the voltage threshold **1202**. As seen, V_2 can be adjusted in time so long as the sum is kept below the voltage threshold **1202**.

FIG. **13** illustrates a power supply system showing details of one embodiment of a voltage multiplier modifier. The voltage multiplier modifier **1330** can include a diode **1334**, an inductor **1332**, and a switch **1336**. The combination of the inductor **1332**, the switch **1336**, and the diode **1334** can function as a discontinuous conduction mode (DCM) boost converter, where the inductor **1332** current can fall to zero for at least a portion of operation. The combination can also function as a continuous conduction mode (CCM) boost converter, where the inductor **1332** current never falls to zero.

The inductor **1332** can be arranged between the voltage multiplier **1324** and an electrical node **1333**, where the electrical node **1333** is arranged between the diode **1334** and the switch **1336**. In particular the electrical node **1333** can be arranged between an anode of the diode **1334** and the switch **1336**. The switch **1336** can be arranged between the electrical node **1333** and a second rail **1352**. When the switch **1336** closes, stored energy in the voltage multiplier **1324** is removed through the inductive component **1332** and the unidirectional switch **1334** to the first rail **1350**, thus lowering the voltage across the voltage multiplier **1324** and hence lowering the voltage boost V_2 caused by energy storage in the voltage multiplier **1324**.

The switch **1334** can be turned on and off according to a duty cycle, where a larger duty cycle decreases the voltage boost V_2 from the voltage multiplier **1324**. For instance, a 0% duty cycle (the switch **1334** open 100% of the time) allows the full voltage boost V_2 of the voltage multiplier **1324** to reach the switching circuit **1304**.

FIG. **14** illustrates a power supply system showing details of one embodiment of a voltage multiplier **1424** and of a voltage multiplier modifier **1430**. The details of the voltage multiplier modifier **1430** are the same as those illustrated in FIG. **13**, and the details of the voltage multiplier **1424** are the same as those illustrated in FIG. **9**. The voltage multiplier **1124** can include a first capacitor **1408**, a second capacitor **1416**, a first diode **1418**, a second diode **1422**, and an optional third diode **1420**.

During switching of the switching circuit **1404** when the plasma load **1406** appears as an inductor or an open circuit, power from the DC power supply **1402** passes through the diode **1410** and into the voltage multiplier **1424**. Due to the arrangement of the diodes **1418**, **1422**, **1420** the current charges the first capacitor **1408** and the second capacitor **1416** in series while passing through the diodes **1410** and **1422**. The diode **1418** and the optional diode **1420** are reverse biased during charging of the first and second capacitors **1408**, **1416**.

When the voltage multiplier **1424** discharges, and the voltage multiplier module **1430** is not active, the second diode **1422** is reverse biased and the first diode **1418** and the optional third diode **1420**, if implemented, are forward biased. As a result, the first and second capacitors **1408** and **1416** discharge in parallel. The voltage that the first and second capacitors **1408** and **1416** are each charged to can be equivalent to the process voltage, V_2 , minus a forward bias voltage drop across the diode **1410**. In other words, the voltage multiplier **1424** approximately doubles the voltage provided by the DC power supply **1402**, and can be referred to as a voltage doubler.

12

The voltage multiplier modifier **1430** can control how much of the voltage doubling effect the voltage multiplier **1424** has on V_{AB} . For instance, where the switch **1426** has a maximum safe operating voltage threshold of 1700 V, and V_1 is 1000 V, the voltage multiplier module **1424** by itself would generate a 2000 V rail voltage on the first rail **1450** and thus damage the switch **1426**. However, via proper control of the voltage multiplier modifier **1430** the multiplying effect of the voltage modifier **1424** can be tailored such that V_{AB} is kept below 1700 V, thus avoiding damage to the switch **1426**.

In particular, when the switch **1436** is closed, energy from the capacitor **1416** is removed to the second rail **1452** via an output **1460** of the voltage multiplier, the inductor **1432**, and the closed switch **1436**. As such, the more often the switch **1436** is closed (e.g., a higher duty cycle), the lower the voltage on the capacitor **1416**. The voltage multiplier modifier **1430** does not affect the voltage on the capacitor **1408**. In this fashion, the voltage multiplier modifier **1430** can control the boost voltage V_2 provided by the voltage multiplier **1424**.

When the first and second capacitors **1408**, **1416** discharge, and the voltage multiplier modifier **1430** is active, the first capacitor **1408** discharges via the switch **1426**, the inductor **1412**, and the optional diode **1414**. Because charge has been removed from the second capacitor **1416**, the optional diode **1420** is reverse biased, and can be removed from the circuit when the voltage multiplier modifier **1430** is used. The second capacitor **1416** discharges through the voltage multiplier modifier **1430**, and in particular through the inductor **1432** and the diode **1434**.

Discussion will now be directed to current paths, voltages, and forward or reverse biases existing on the various components illustrated in FIG. **14** during different phases of operation of one embodiment of a power supply system. The DC power supply **1402** can be power or current-regulated. During non-arcing conditions, current passes along first rail **1450** from the DC power supply **1402** to the switching circuit **1404**. The switch **1426** is closed (or on), and the diodes **1410** and **1414** are also on, and thus current also passes in a near-lossless loop **1411** (see FIG. **17**) through the inductor **1412**, the diode **1410**, the closed switch **1426**, and the diode **1414** (optional). A voltage, V_{AB} , is equal to a process voltage during this phase of operation. The process voltage is a voltage across the plasma load **1406** given a steady state plasma impedance. This occurs when the plasma is ignited and sustained and thus is conducting, but can vary to some extent depending on plasma stability and process conditions (e.g., when reactive gas flow enters the plasma processing chamber). A voltage, V_{EB} , as measured from electrical node E to electrical node B is equal to the process voltage minus the forward conduction voltage drop across diode **1410** (e.g., $V_{EB}=V_{AB}-V_{AE}$).

The constant current loop **1411** (see FIG. **17**) maintains the diodes **1410** and **1414** (optional) in an on state, thus providing the first rail **1450** instant access to the voltage multiplier **1424** should the plasma load impedance **1406** rise for any reason. Thus, the voltage multiplier **1424** is ready to absorb power from the DC power supply **1402** after every 0 V transition of the switching circuit **1404** as well as after any malfunction caused by an impedance spike in the plasma load **1406**. For instance, where there is a leak in the plasma chamber that suddenly extinguishes the plasma, power from the DC power supply **1402** can be shunted into the voltage multiplier **1424**.

FIG. **18** illustrates the power supply system of FIG. **14** just after a 0 V transition of the switching circuit. After the

0 V transition, the plasma load **1406** impedance rises substantially such that the path of least resistance for most of the current is through diode **1410**, first capacitor **1408**, diode **1422**, and capacitor **1416** to the second rail **1452** (**1452** is mislabeled in FIG. **18** as **1442**). Diode **1418** is reverse biased, as is optional diode **1420** if implemented. The voltage between the rails, V_{AB} , when the current begins to take this route, is equal to the process voltage, V_1 . The current charges the capacitors **1408** and **1416** and in doing so increases V_{AB} above the process voltage, V_1 . With the illustrated voltage multiplier **1424** (a voltage doubler), V_{AB} can be boosted to substantially twice the processing voltage, V_1 . In other embodiments, the voltage can be boosted to three, four, or any integer or fractional multiplier of the process voltage, V_1 .

The current running along this path and the corresponding charging of the first and second capacitors **1408** and **1416** gradually falls off as the capacitors **1408** and **1416** are charged. Eventually the current flow tapers to a negligible amount or the current in the plasma ramps sufficiently to draw down the plasma load **1406** impedance to normal levels, such that power again is delivered to the plasma load **1406**. When this happens, the voltage across the voltage multiplier, V_{EB} , is typically large enough to forward bias diode **1418** as well as optional diode **1420** if implemented, and diode **1422** turns off. The resulting current flow and diode biasing is illustrated in FIG. **19**. Here, the capacitors **1408** and **1416** discharge in parallel through the closed switch **1426**, the inductor **1412**, and the optional diode **1414** until the capacitors **1408** and **1416** return to a voltage at which diodes **1418** and **1420** turn off (e.g., near process voltage).

In embodiments, where the voltage multiplier modifier **1430** is used to remove some portion of charge on the second capacitor **1416**, optional diode **1420** is not needed, and in such embodiments the optional diode **1420** is reverse biased even if implemented. Either way, the second capacitor **1416** discharges via the inductor **1432** and diode **1434** rather than via the illustrated current path through optional diode **1420**.

As the capacitors **1408** and **1416** discharge, the voltage V_{AB} drops from V_1+V_2 to V_1 or the process voltage as seen in FIGS. **8A** and **8B**. However, this current flow can also cause the voltage fall time to be finite as illustrated in FIGS. **25A** and **25B**. FIGS. **25A** and **25B** illustrate the plots in FIGS. **8A** and **8B**, but include detail of the sloped voltage decrease **2500** attributable to the discharge of the capacitors **1408** and **1416** after the plasma impedance falls to normal levels.

As seen, diode **1410** is still forward biased, thus continuing to provide an instant shunt for power from the DC power supply **1402** to the voltage multiplier **1424** should it be needed. Even small amounts of power from the DC power supply **1402** can be directed into the voltage multiplier **1424**, where the energy builds until the diodes **1418** and **1420** turn on and begin to discharge the capacitors **1408** and **1416**. In this way, the capacitors **1408** and **1416** remain at voltages near or slightly above process voltage.

FIG. **20** illustrates the current paths and diode biases in the power supply system of FIG. **14** during a single arc event. During an arc, the plasma load impedance **1406** drops causing the voltage V_{AB} to drop. When this happens, the voltage V_{AB} typically falls below the voltage V_{EB} , which reverse biases the diode **1410** (illustrated as forward biased). While the voltage multiplier **1424** does discharge energy into the arc, the discharge is not large since the inductor **1412** limits the rise in current. In some cases, the inductor **1412** can be selected to be so large, that even during such an

arc, the current does not appreciably rise. Thus, the voltage multiplier **1424** does not threaten to exacerbate arcs.

The current leaves the snubber and heads to the switching circuit **1404** as well as back into the near-lossless loop **1411**. If two arcs occur back-to-back, then the current in the inductor **1412** may step upwards due to multiple discharges from the capacitors in the voltage multiplier **1424**. A series of arcs in rapid succession can stepwise increase the current to levels that could damage the diodes **1410** and **1414**. Thus, when the current in the inductor **1412** reaches a threshold, the switch **1426** opens as seen in FIG. **21**. The opening of the switch **1426** cuts the near-lossless loop **1411** and forces the inductor **1412** current to discharge into the voltage multiplier **1424**. The inductor **1412** current ramps down and thus opening of the switch **1426** avoids runaway stepwise current ramping in the near-lossless loop **1411**.

The current is illustrated as leaving the optional diode **1414** and heading either back to the diode **1410** or to the switching circuit **1404**. In some cases, both current paths will be used. However, where the switching circuit **1404** is open, current does not pass to the switching circuit **1404** and instead all current passes through diode **1410** to the voltage multiplier **1424**. In cases where the switching circuit **1404** is closed and there is an arc, current will prefer the path into the switching circuit **1404** and the arc. However, after the arc has ceased, or at least diminished, current may be more equally split between the two paths.

Optional diode **1428** can be included between the inductor **1412** and the second rail **1452** to provide a current path to the inductor **1412** when the switch **1426** opens, thereby avoiding voltage spikes in the inductor **1412**.

Duty cycle control can be used to control the switch **1426**, limiting the voltage between the rails **1450**, **1452** as a protection of the snubber circuit **108** (FIG. **1**) and the switching circuit **104**. If the voltage increases above a set level V_{max} , the switch **1426** closes and the voltage across capacitors **1408** and **1416** drops towards the process voltage of the plasma. If the voltage across the rails **1450**, **1452** is below set minimum voltage V_{min} then switch **1426** opens. The control range is between the voltage across capacitor **1408** and the voltage across the capacitor **1416**. The advantage of this control using the switch **1426** is that the voltage boost is independent from this control.

Similar control could be used to control the switch **1436** to keep the voltage across the capacitor **1416** within a range. It requires an additional measurement of that voltage to be applied. It would replace duty cycle control and allows automatic synchronization of the switching frequency of switch **1436** to the switching frequency of the circuit **1404**. The value $V_{max}-V_{min}$ defines the duty cycle of the switches **1436**, **1426** as a multiple of the double of the switches **1436**, **1426**, because the first and second capacitors **1408**, **1416** are only charged during a first portion of each pulse from the switching circuit **1404**, when the plasma has a high impedance and thus cannot draw the full current delivered from the DC power supply **1402**, the inductor **1412**, and the inductor **1432**.

A voltage sensor (not illustrated) can monitor a voltage across the second capacitor **1416** and provide feedback to a control of the switch **1436** to control opening and closing of the switch **1436** or a duty cycle of the switch **1436**. In other words, the switch **1436** can open and close, or have a duty cycle, responsive to feedback from a voltage sensor monitoring the voltage across the second capacitor **1416**.

FIG. **15** illustrates a power supply system including a DC power supply providing power to a switching circuit, which then provides pulsed DC power to a plasma load. A snubber

1508 can be incorporated into the DC power supply **1502**, and power can be provided from the snubber **1508** to the switching circuit **1504**.

FIG. **16** illustrates a power supply system including a DC power supply providing power to a switching circuit, which then provides pulsed DC power to a plasma load. A snubber **1608** can be incorporated into the switching circuit **1604**, and power can be provided from the DC power supply **1602** to the snubber **1608**.

FIG. **26** illustrates a method of controlling power in a power supply system. The method **2600** can begin with the passage of power from a power supply (e.g., DC power supply) to a load via a pass power operation **2602**. The load can have an impedance, and the impedance can change in time. When the impedance substantially increases, an absorbing at least some of the power operation **2604** can absorb at least some of the power from the power supply. Absorption of the power can cause a boost or increase to voltage and current reaching the load (e.g., **8A**, **8B**, **12**, **25**). After absorption of the power, the method **2600** can include a discharging at least some of the absorbed power operation **2606** where at least some of the absorbed power is discharged into the load. This discharge can be activated by a decrease in the load impedance and can take place in a substantially non-dissipative fashion. After the discharge operation **2606**, the method **2600** can end or return to the passing power operation **2602**.

Although this disclosure has focused on embodiments where snubbers are used to mitigate voltage and current spikes (or ramps) in a power supply system, and in particular for pulsed DC applications, it is envisioned that the disclosed snubber can be used in a variety of other voltage and/or current clamping situations.

FIG. **22** illustrates another embodiment of a power supply system. A power supply (DC or AC) **2002** provides power to a load **2006** via first and second rails **2050** and **2052**. The load **2006** can be a plasma load or any other type of load (e.g., a DC or AC electrical motor). A single magnetron sputtering system is one implementation of such a power supply system. A snubber **2004** can be coupled to the rails **2050** and **2052** between the power supply **2002** and the load **2006** and can be configured to absorb power from the power supply **2002** when an impedance of the load **2006** increases. As the load **2006** impedance decreases, the snubber **2004** can discharge some of its stored energy into the load **2006** to supplement power from the power supply **2002**. Because little to no energy is dissipated in the snubber **2004**, the snubber can be referred to as a non-dissipative snubber.

The snubber **2004** is further configured to temporarily boost a voltage as measured from the first rail **2050** to the second rail **2052**, again in a non-dissipative manner. If the power supply **2002** is a power-regulated supply, then the voltage boost will result in faster current ramping when the power is first applied, or when power is reapplied in a pulsing context. This can decrease power turn on time, which can be useful in semiconductor fabrication applications, to name one example. For instance, where there is a problem with the load **2006** that drives the load **2006** impedance high (e.g., loss of plasma conductivity in a plasma processing chamber), power can be more quickly reapplied to the load **2006** after the problem has been resolved than with known snubbers.

FIG. **23** illustrates yet another power supply system. A power supply (DC or AC) **2102** provides power to a load **2106** via first and second rails **2150** and **2152** and via vulnerable circuitry **2106**. Vulnerable circuitry includes any circuitry that can be damaged by excessive voltages, cur-

rents or power and in particular can be damaged when an impedance of the load **2108** increases. A snubber **2104** can be coupled to the rails **2150** and **2152** between the power supply **2102** and the vulnerable circuitry **2106** and can be configured to absorb power from the power supply **2102** when an impedance of the load **2108** increases. In this way the snubber **2104** can prevent excessive power, voltages or currents from passing through the vulnerable circuitry **2106** and damaging components therein.

Returning to FIG. **24** illustrates yet a further power supply system. The power supply system **2400** can include a power supply **2402**, a load **2406**, a non-dissipative snubber **2460**, and optionally vulnerable circuitry **2404**. The snubber **2460** can be arranged between the power supply **2402** and the load **2406**. The optional vulnerable circuitry **2404** can be arranged between the snubber **2460** and the load **2406**.

The snubber **2460** functions much like the snubbers disclosed throughout this disclosure. However, the snubber **2460** does so using more generalized components, in order to show applications outside of the pulsed DC environment. For instance, rather than diodes, the snubber **2460** can include unidirectional switches **2410**, **2414**, and **2416**. The snubber **2460** can also include an optional current limiter **2408** in series with the unidirectional switch **2410** as well as a current limiter **2412** in series with the unidirectional switch **2414**. The snubber **2460** includes a switch **2422** and a voltage multiplier **2418**. Optionally, the snubber **2460** can include a voltage multiplier modifier **2420**. The snubber **2460** may further include an optional unidirectional switch **2404** arranged between the current limiter **2412** and the second rail **2452**.

In some embodiments, the unidirectional switch **2410** can be arranged in series with the optional current limiter **2408**, such as an inductor, so as to limit not only the direction of current into the voltage multiplier **2424**, but to also limit the amount and rate of change of current entering the voltage multiplier **2424**. Such an optional current limiter **2408** may be implemented to prevent current overload in the voltage multiplier **2424**. In embodiments, where two or more of the herein disclosed snubbers **2460** are arranged in parallel, the optional current limiter **2408** may limit the current entering each of the snubbers so that voltage can remain at a reasonable level while still sending current to each of the two or more snubbers.

In such an embodiment, the optional current limiter **2408** in series with the first unidirectional switch **2410** can be selected so that current is able to rapidly enter and charge the voltage multiplier **2418**, while the current limiter **2412** can be selected so that the voltage multiplier **2418** discharges at a lower current. This can lead to a rapid boosting of voltage to $V_1 + V_2$ at the start of each DC pulse (see the first portion **802** of FIGS. **8A** and **8B**) while the voltage multiplier **2418** supplements the power supply **2402** current at V_1 over a longer second portion of each DC pulse.

In one embodiment, the first and second rails **2450** and **2452** are floating, such that neither is referenced to ground. The optional unidirectional switch **2414** can be excluded where an LC time constant is long. A "long" LC time constant is long enough to prevent the current limiter **2412** current from reversing direction. In particular, current in the current limiter **2412** would be sinusoidal without the optional unidirectional switch **2414**, and so the LC time constant is preferably equal to a switching frequency of the vulnerable circuitry **2404**, assuming the vulnerable circuitry **2404** includes a switching frequency. In a further preferred embodiment, the LC time constant is an order of magnitude greater than the switching frequency of the vulnerable

circuitry **2404**, assuming the vulnerable circuitry **2404** includes a switching frequency. The LC time constant can be calculated from the inductance of the current limiter **2412** and any capacitance of the voltage multiplier **2424**. Two non-limiting examples of the vulnerable circuitry **2404** are an H-bridge (half or full bridge) and a double-pole double-throw switch network.

The load **2406** can be part of a plasma processing chamber, such as those used in plasma sputtering. Power can be provided to the load **2406** via one or more electrodes such as those in dual-magnetron sputtering (one or more magnetrons can also be used).

One of skill in the art will recognize that the plots of voltage and current (e.g., FIGS. **2A**, **2B**, **8A**, **8B**, **25A**, and **25B**) are not necessarily drawn to scale, and that the shape and scale of different features of the waveforms can change depending on the circuits used to generate these waveforms. For instance, the pulse width of the voltage increase at the start of each pulse may vary depending on the power passing to the snubber and depending on capacitance values within the snubber (e.g., the capacitances of the first capacitor **1408** and the second capacitor **1416** in FIG. **14**). As another example, vertical aspects of the voltage pulses illustrated in FIGS. **8A** and **8B** may have less than infinite slope in practice. For instance, the falling edge of the boosted voltage (the first portion of each pulse) can have a negative slope that is a function of inductance and capacitance. The front vertical aspect of each pulse can in practice include an exponentially increasing portion for V_2 where the boost voltage rises above V_1 as a function of charge accumulation on the capacitors **1408** and **1416** in FIG. **14**. Furthermore, while the current waveforms show a flat or near flat portion during a latter portion of each pulse, in practice the slope of this portion of the current waveform can vary and be non-zero. These examples demonstrate that the plots of voltage and current in the figures are meant as illustrations and generalizations only, and that variations on these specific waveforms can be made without departing from the scope of this disclosure.

FIG. **28** illustrates an alternative topology for a voltage-boosting circuit of a pulsed DC power supply system. The voltage-boosting circuit **2804** can have functionality of a snubber and can be used to both boost the rail voltage V_{AB} as well as to absorb current and/or power from a DC power supply providing power to the rails **2850**, **2852**. The voltage-boosting circuit **2804** includes a first diode **2810**, a capacitor **2812**, a switch **2814**, a second diode **2816**, a third diode **2818**, and an inductor **2820**. Unlike other voltage-boosting circuits having snubber functionality, here the switch **2814** remains open (off) until the capacitor **2812** charges to a desired boosted voltage ($V_1 + V_2$). Other voltage-boosting circuits can be limited to a boosted voltage equal to twice the process voltage (V_1) and greater than twice the average rail voltage V_{AB} . Because the switch **2814** of the illustrated voltage-boosting circuit **2804** can be left open indefinitely, the capacitor **2812** can charge to greater than twice the process voltage (V_1) and greater than twice the average rail voltage V_{AB} . Charge and voltage on the capacitor **2812** is in part a function of a duty cycle of the switch **2814**.

When the switching circuit **2806** switches and plasma impedance rises, so does the rail voltage V_{AB} . This rise in rail voltage V_{AB} forward biases the first diode **2810** allowing current to run into the capacitor **2812** and charge the voltage across the capacitor **2812**. When the switch **2814** is open (off) the capacitor **2812** can be charged as long as the rail voltage V_{AB} is greater than the capacitor **2812** voltage plus a diode voltage drop across the first diode **2810**. The

capacitor **2812** voltage can therefore be charged to voltages greater than twice a process voltage V_1 and twice an average rail voltage V_{AB} .

When the switch is closed (on) the capacitor **2812** discharges through inductor **2820** raising the instantaneous rail voltage V_{AB} . As the capacitor **2812** discharges, the instantaneous rail voltage V_{AB} decreases until the instantaneous rail voltage V_{AB} is lower than a voltage across the capacitor **2812**, at which point the first diode **2810** becomes reverse biased and current ceases to charge the capacitor **2812**. The rail voltage V_{AB} then remains at this voltage, a process voltage V_1 , until switching occurs and the plasma impedance again rises and forward biases the first diode **2810**. When the switch **2814** opens, the third diode **2818** provides a current path to the inductor **2820** to enable current to continue flowing through the inductor **2820** as the current ramps down.

One of skill in the art will recognize that the voltage-boosting circuit **2804** can be implemented for the snubbers described with reference to FIGS. **1-27**.

FIG. **29** illustrates another embodiment of a voltage-boosting circuit **2905** having snubber functionality. The voltage-boosting circuit **2905** includes a first diode **2910**, a first switch **2926**, a second and optional switch **2936**, a first inductor **2912**, a second inductor **2932**, a second diode **2930**, a third and optional diode **2928**, and a voltage multiplier **2924**. The voltage multiplier **2924** includes a first capacitor **2908**, a second capacitor **2916**, a fourth diode **2918**, and a fifth diode **2922**.

The optional second switch **2936** is typically open, or in its absence, the second inductor **2932** is merely coupled to a first rail **2950** via the second diode **2930**. The first switch **2926** typically is closed (on).

When the switching circuit **2904** switches, the plasma impedance rises as does the rail voltage V_{AB} , which forward biases the first diode **2910** and sends current into the voltage multiplier **2924**. In particular, the current charges the first capacitor **2908** and charges the second capacitor **2916**. Both capacitors **2908**, **2916** charge until an average rail voltage V_{AB} is seen across each capacitor **2908**, **2916**.

Although the capacitors **2908**, **2916** each charge to the average rail voltage V_{AB} , they can see instantaneous voltage in excess of the average rail voltage V_{AB} , and for safety, there is a desire to mitigate these overvoltages. This is where the optional second switch **2936** can be used. The optional second switch **2936** can operate according to a hysteresis control algorithm. The second capacitor **2916** can discharge via an output **2960** of the voltage multiplier **2924** and through the second inductor **2932** and the second diode **2930**. The optional second switch **2936** can close when a voltage across the second capacitor **2916** rises above a maximum voltage threshold V_{max} in order to lower the voltage across the second capacitor **2916**. In an alternative, the second optional switch **2936** can begin switching at a defined duty cycle configured to lower a voltage across the second capacitor **2916**. Alternatively, the second optional switch **2936** may already be switching when the voltage across the second capacitor **2916** rises above the maximum voltage threshold V_{max} . In this case the second optional switch **2936** can increase its duty cycle so as to lower the voltage across the second capacitor **2916**.

Whichever of these methods is implemented, the second optional switch **2936** persists in operation (e.g., closed, defined duty cycle, or an increased duty cycle) until the voltage across the second capacitor **2916** falls below a minimum voltage threshold V_{min} . The second optional switch **2936** can then open, or decrease its duty cycle. The

second optional switch **2936** can remain open or maintain the decreased duty cycle until the voltage across the second capacitor **2916** again exceeds the maximum voltage threshold V_{max} . This overvoltage hysteresis control prevents transient voltages from damaging the electronics or generating unwanted high energy ions in the plasma.

The value $V_{max}-V_{min}$ defines the duty cycle of the second optional switch **2936** as a multiple of the double of the second optional switch **2936**, because the first and second capacitors **2908**, **2916** are only charged during a first portion of each pulse from the switching circuit **2904**, when the plasma has a high impedance and thus cannot draw the full current delivered from the DC power supply **2902**, the first inductor **2912**, and the second inductor **2932**.

A voltage sensor (not illustrated) can monitor a voltage across the second capacitor **2916** and provide feedback to a control of the optional second switch **2936** to control opening and closing of the optional second switch **2936** or a duty cycle of the optional second switch **2936**. In other words, the optional second switch **2936** can open and close, or have a duty cycle, responsive to feedback from a voltage sensor monitoring the voltage across the second capacitor **2916**.

As noted earlier, while this discussion has focused on embodiments where a single pulsed DC power supply system powers a single anodeless electrode pair, in other embodiments, multiple anodeless electrode pairs can be implemented. In some cases, a single pulsed DC power supply system can provide pulsed DC power to each anodeless electrode pair, while in other embodiments, there may be a separate pulsed DC power supply system for each anodeless electrode pair.

In one embodiment, the use of a plurality of pulsed DC power supply systems each feeding one of a plurality of anodeless electrode pairs, can be paired with different boost voltages V_2 to each electrode pair so as to effectuate a desired processing effect including a desired film property (e.g., optical characteristic, resistance, and stress) or processing characteristic (e.g., sputtering rate).

For instance, an embodiment could include a first pulsed DC power supply system providing a first pulsed DC power to a first anodeless electrode pair, the first pulsed DC power having a first boost voltage V_2 , and a second pulsed DC power supply system providing a second pulsed DC power to a second sputtering cathode and a second anode, the second pulsed DC power having a second boost voltage V_2' . In another embodiment, the first boost voltage V_2 can be provided to a first anodeless electrode while the second boost voltage V_2' can be provided to a second anodeless electrode. The first and second anodeless electrodes can both operate as an anode, a cathode, and a sputtering target and may be adjacent to each other (e.g., no targets or electrodes separate the first and second anodeless electrode). V_2 and V_2' can be non-equal and thus effectuate a desired processing effect. In this way, not only can different process voltages, different duty cycles, and different frequencies be applied to different electrodes, but additional control over the boost voltages to different anodeless electrode pairs is now possible.

FIG. **30** illustrates an embodiment of a power supply system including two or more pulsed DC power supply systems providing pulsed DC power to four or more anodeless electrodes in a plasma processing chamber. Each pulsed DC power supply **3001**, **3002** can embody any of the circuits and functionality as described earlier with reference to various embodiments of pulsed DC power supply systems (e.g., FIGS. **1-28**). The pulsed DC power supply systems

3001, **3002** can generate pulsed DC power having a boosted voltage (V_1+V_2) during a first portion of each pulse (e.g., FIG. **12**).

Each pulsed DC power supply system **3001**, **3002** can power a pair of anodeless electrodes. For instance, the first pulsed DC power supply system **3001** provides pulsed DC voltage having a voltage V_{CD} to first and second anodeless electrodes **3010**, **3012**. The second pulsed DC power supply system **3002** provides pulsed DC voltage having a voltage V_{EF} to third and fourth anodeless electrodes **3014**, **3016**. The anodeless electrodes operate as anodes, cathodes, and sputtering targets.

The boost voltage V_2 provided by each pulsed DC power supply system **3001**, **3002** can be selectable and differ from one pulsed DC power supply to another. For instance, a first boost voltage V_2 can be applied to the first and second anodeless electrodes **3010**, **3012**, while a second boost voltage V_2 can be applied to the third and fourth anodeless electrodes **3014**, **3016**.

The systems and methods described herein can be implemented in a computer system in addition to the specific physical devices described herein. FIG. **27** shows a diagrammatic representation of one embodiment of a computer system **2700** within which a set of instructions can execute for causing a device to perform or execute any one or more of the aspects and/or methodologies of the present disclosure. The non-illustrated controllers or other control components described above are one implementation of the computer system **2700**. The components in FIG. **27** are examples only and do not limit the scope of use or functionality of any hardware, software, firmware, embedded logic component, or a combination of two or more such components implementing particular embodiments of this disclosure. Some or all of the illustrated components can be part of the computer system **2700**. For instance, the computer system **2700** can be a general purpose computer (e.g., a laptop computer) or an embedded logic device (e.g., an FPGA), to name just two non-limiting examples.

Computer system **2700** can include at least one processor **2701** such as a central processing unit (CPU) or an FPGA to name two non-limiting examples. The computer system **2700** may also comprise a memory **2703** and a storage **2708**, both communicating with each other, and with other components, via a bus **2740**. The bus **2740** may also link a display **2732**, one or more input devices **2733** (which may, for example, include a keypad, a keyboard, a mouse, a stylus, etc.), one or more output devices **2734**, one or more storage devices **2735**, and various non-transitory, tangible computer-readable storage media **2736** with each other and with one or more of the processor **2701**, the memory **2703**, and the storage **2708**. All of these elements may interface directly or via one or more interfaces or adaptors to the bus **2740**. For instance, the various non-transitory, tangible computer-readable storage media **2736** can interface with the bus **2740** via storage medium interface **2726**. Computer system **2700** may have any suitable physical form, including but not limited to one or more integrated circuits (ICs), printed circuit boards (PCBs), mobile handheld devices (such as mobile telephones or PDAs), laptop or notebook computers, distributed computer systems, computing grids, or servers.

Processor(s) **2701** (or central processing unit(s) (CPU(s))) optionally contains a cache memory unit **2702** for temporary local storage of instructions, data, or computer addresses. Processor(s) **2701** are configured to assist in execution of computer-readable instructions stored on at least one non-transitory, tangible computer-readable storage medium. Computer system **2700** may provide functionality as a result

of the processor(s) 2701 executing software embodied in one or more non-transitory, tangible computer-readable storage media, such as memory 2703, storage 2708, storage devices 2735, and/or storage medium 2736 (e.g., read only memory (ROM)). For instance, methods of operating the switches and power supplies in FIGS. 6-7, 9-11, 13-24, 28-29 and the method of FIG. 26 may be embodied in one or more non-transitory, tangible computer-readable storage media. The non-transitory, tangible computer-readable storage media may store software that implements particular embodiments, such as the methods of operating the switches and power supplies in FIGS. 6-7, 9-11, 13-24, 28-29 and the method of FIG. 26, and processor(s) 2701 may execute the software. Memory 2703 may read the software from one or more other non-transitory, tangible computer-readable storage media (such as mass storage device(s) 2735, 2736) or from one or more other sources through a suitable interface, such as network interface 2720. For instance, the switches and power supplies in FIGS. 6-7, 9-11, 13-24, 28-29 may be remotely interfaced with via a network interface such as 2720. The software may cause processor(s) 2701 to carry out one or more processes or one or more steps of one or more processes described or illustrated herein. Carrying out such processes or steps may include defining data structures stored in memory 2703 and modifying the data structures as directed by the software. In some embodiments, an FPGA can store instructions for carrying out functionality as described in this disclosure (e.g., the methods of operating the switches and power supplies in FIGS. 6-7, 9-11, 13-24, 28-29 and the method of FIG. 26). In other embodiments, firmware includes instructions for carrying out functionality as described in this disclosure (e.g., the methods of operating the switches and power supplies in FIGS. 6-7, 9-11, 13-24, 28-29 and the method of FIG. 26).

The memory 2703 may include various components (e.g., non-transitory, tangible computer-readable storage media) including, but not limited to, a random access memory component (e.g., RAM 2704) (e.g., a static RAM "SRAM", a dynamic RAM "DRAM, etc.), a read-only component (e.g., ROM 2705), and any combinations thereof. ROM 2705 may act to communicate data and instructions unidirectionally to processor(s) 2701, and RAM 2704 may act to communicate data and instructions bidirectionally with processor(s) 2701. ROM 2705 and RAM 2704 may include any suitable non-transitory, tangible computer-readable storage media described below. In some instances, ROM 2705 and RAM 2704 include non-transitory, tangible computer-readable storage media for carrying out the methods of operating the switches and power supplies in FIGS. 6-7, 9-11, 13-24, 28-29 and the method of FIG. 26. In one example, a basic input/output system 2706 (BIOS), including basic routines that help to transfer information between elements within computer system 2700, such as during start-up, may be stored in the memory 2703.

Fixed storage 2708 is connected bidirectionally to processor(s) 2701, optionally through storage control unit 2707. Fixed storage 2708 provides additional data storage capacity and may also include any suitable non-transitory, tangible computer-readable media described herein. Storage 2708 may be used to store operating system 2709, EXECs 2710 (executables), data 2711, API applications 2712 (application programs), and the like. For instance, the storage 2708 could be implemented for storage of thresholds used to trigger switching of the switch 2814 in FIG. 28. Often, although not always, storage 2708 is a secondary storage medium (such as a hard disk) that is slower than primary storage (e.g., memory 2703). Storage 2708 can also include an optical

disk drive, a solid-state memory device (e.g., flash-based systems), or a combination of any of the above. Information in storage 2708 may, in appropriate cases, be incorporated as virtual memory in memory 2703.

In one example, storage device(s) 2735 may be removably interfaced with computer system 2700 (e.g., via an external port connector (not shown)) via a storage device interface 2725. Particularly, storage device(s) 2735 and an associated machine-readable medium may provide nonvolatile and/or volatile storage of machine-readable instructions, data structures, program modules, and/or other data for the computer system 2700. In one example, software may reside, completely or partially, within a machine-readable medium on storage device(s) 2735. In another example, software may reside, completely or partially, within processor(s) 2701.

Bus 2740 connects a wide variety of subsystems. Herein, reference to a bus may encompass one or more digital signal lines serving a common function, where appropriate. Bus 2740 may be any of several types of bus structures including, but not limited to, a memory bus, a memory controller, a peripheral bus, a local bus, and any combinations thereof, using any of a variety of bus architectures. As an example and not by way of limitation, such architectures include an Industry Standard Architecture (ISA) bus, an Enhanced ISA (EISA) bus, a Micro Channel Architecture (MCA) bus, a Video Electronics Standards Association local bus (VLB), a Peripheral Component Interconnect (PCI) bus, a PCI-Express (PCI-X) bus, an Accelerated Graphics Port (AGP) bus, HyperTransport (HTX) bus, serial advanced technology attachment (SATA) bus, and any combinations thereof.

Computer system 2700 may also include an input device 2733. In one example, a user of computer system 2700 may enter commands and/or other information into computer system 2700 via input device(s) 2733. Examples of an input device(s) 2733 include, but are not limited to, an alphanumeric input device (e.g., a keyboard), a pointing device (e.g., a mouse or touchpad), a touchpad, a joystick, a gamepad, an audio input device (e.g., a microphone, a voice response system, etc.), an optical scanner, a video or still image capture device (e.g., a camera), and any combinations thereof. Input device(s) 2733 may be interfaced to bus 2740 via any of a variety of input interfaces 2723 (e.g., input interface 2723) including, but not limited to, serial, parallel, game port, USB, FIREWIRE, THUNDERBOLT, or any combination of the above.

In particular embodiments, when computer system 2700 is connected to network 2730, computer system 2700 may communicate with other devices, such as mobile devices and enterprise systems, connected to network 2730. Communications to and from computer system 2700 may be sent through network interface 2720. For example, network interface 2720 may receive incoming communications (such as requests or responses from other devices) in the form of one or more packets (such as Internet Protocol (IP) packets) from network 2730, and computer system 2700 may store the incoming communications in memory 2703 for processing. Computer system 2700 may similarly store outgoing communications (such as requests or responses to other devices) in the form of one or more packets in memory 2703 and communicated to network 2730 from network interface 2720. Processor(s) 2701 may access these communication packets stored in memory 2703 for processing.

Examples of the network interface 2720 include, but are not limited to, a network interface card, a modem, and any combination thereof. Examples of a network 2730 or network segment 2730 include, but are not limited to, a wide

area network (WAN) (e.g., the Internet, an enterprise network), a local area network (LAN) (e.g., a network associated with an office, a building, a campus or other relatively small geographic space), a telephone network, a direct connection between two computing devices, and any combinations thereof. A network, such as network 2730, may employ a wired and/or a wireless mode of communication. In general, any network topology may be used.

Information and data can be displayed through a display 2732. Examples of a display 2732 include, but are not limited to, a liquid crystal display (LCD), an organic liquid crystal display (OLED), a cathode ray tube (CRT), a plasma display, and any combinations thereof. The display 2732 can interface to the processor(s) 2701, memory 2703, and fixed storage 2708, as well as other devices, such as input device(s) 2733, via the bus 2740. The display 2732 is linked to the bus 2740 via a video interface 2722, and transport of data between the display 2732 and the bus 2740 can be controlled via the graphics control 2721.

In addition to a display 2732, computer system 2700 may include one or more other peripheral output devices 2734 including, but not limited to, an audio speaker, a printer, and any combinations thereof. Such peripheral output devices may be connected to the bus 2740 via an output interface 2724. Examples of an output interface 2724 include, but are not limited to, a serial port, a parallel connection, a USB port, a FIREWIRE port, a THUNDERBOLT port, and any combinations thereof.

In addition or as an alternative, computer system 2700 may provide functionality as a result of logic hardwired or otherwise embodied in a circuit, which may operate in place of or together with software to execute one or more processes or one or more steps of one or more processes described or illustrated herein. Reference to software in this disclosure may encompass logic, and reference to logic may encompass software. Moreover, reference to a non-transitory, tangible computer-readable medium may encompass a circuit (such as an IC) storing software for execution, a circuit embodying logic for execution, or both, where appropriate. The present disclosure encompasses any suitable combination of hardware, software, or both.

Those of skill in the art will understand that information and signals may be represented using any of a variety of different technologies and techniques. For example, data, instructions, commands, information, signals, bits, symbols, and chips that may be referenced throughout the above description may be represented by voltages, currents, electromagnetic waves, magnetic fields or particles, optical fields or particles, or any combination thereof.

Within this specification, the same reference characters are used to refer to terminals, signal lines, wires, etc. and their corresponding signals. In this regard, the terms “signal,” “wire,” “connection,” “terminal,” and “pin” may be used interchangeably, from time-to-time, within the this specification. It also should be appreciated that the terms “signal,” “wire,” or the like can represent one or more signals, e.g., the conveyance of a single bit through a single wire or the conveyance of multiple parallel bits through multiple parallel wires. Further, each wire or signal may represent bi-directional communication between two, or more, components connected by a signal or wire as the case may be.

Those of skill will further appreciate that the various illustrative logical blocks, modules, circuits, and algorithm steps described in connection with the embodiments disclosed herein may be implemented as electronic hardware, computer software, or combinations of both. To clearly

illustrate this interchangeability of hardware and software, various illustrative components, blocks, modules, circuits, and steps have been described above generally in terms of their functionality. Whether such functionality is implemented as hardware or software depends upon the particular application and design constraints imposed on the overall system. Skilled artisans may implement the described functionality in varying ways for each particular application, but such implementation decisions should not be interpreted as causing a departure from the scope of the present invention.

The various illustrative logical blocks, modules, and circuits described in connection with the embodiments disclosed herein may be implemented or performed with a general purpose processor, a digital signal processor (DSP), an application specific integrated circuit (ASIC), a field programmable gate array (FPGA) or other programmable logic device, discrete gate or transistor logic, discrete hardware components, or any combination thereof designed to perform the functions described herein. A general purpose processor may be a microprocessor, but in the alternative, the processor may be any conventional processor, controller, or microcontroller. A processor may also be implemented as a combination of computing devices, e.g., a combination of a DSP and a microprocessor, a plurality of microprocessors, one or more microprocessors in conjunction with a DSP core, or any other such configuration.

The steps of a method or algorithm described in connection with the embodiments disclosed herein (e.g., the methods of operating the switches and power supplies in FIGS. 6-7, 9-11, 13-24, 28-29 and the method of FIG. 26) may be embodied directly in hardware, in a software module executed by a processor, a software module implemented as digital logic devices, or in a combination of these. A software module may reside in RAM memory, flash memory, ROM memory, EPROM memory, EEPROM memory, registers, hard disk, a removable disk, a CD-ROM, or any other form of non-transitory, tangible computer-readable storage medium known in the art. An exemplary non-transitory, tangible computer-readable storage medium is coupled to the processor such that the processor can read information from, and write information to, the non-transitory, tangible computer-readable storage medium. In the alternative, the non-transitory, tangible computer-readable storage medium may be integral to the processor. The processor and the non-transitory, tangible computer-readable storage medium may reside in an ASIC. The ASIC may reside in a user terminal. In the alternative, the processor and the non-transitory, tangible computer-readable storage medium may reside as discrete components in a user terminal. In some embodiments, a software module may be implemented as digital logic components such as those in an FPGA once programmed with the software module.

The previous description of the disclosed embodiments is provided to enable any person skilled in the art to make or use the present invention. Various modifications to these embodiments will be readily apparent to those skilled in the art, and the generic principles defined herein may be applied to other embodiments without departing from the spirit or scope of the invention. Thus, the present invention is not intended to be limited to the embodiments shown herein but is to be accorded the widest scope consistent with the principles and novel features disclosed herein.

The previous description of the disclosed embodiments is provided to enable any person skilled in the art to make or use the present invention. Various modifications to these embodiments will be readily apparent to those skilled in the art, and the generic principles defined herein may be applied

to other embodiments without departing from the spirit or scope of the invention. Thus, the present invention is not intended to be limited to the embodiments shown herein but is to be accorded the widest scope consistent with the principles and novel features disclosed herein.

What is claimed is:

1. A pulsed DC power supply system configured to provide pulsed DC power to a plurality of anodeless electrodes of a plasma processing chamber, the pulsed DC power supply comprising:

- a switching circuit coupled to first and second rails and receiving a first DC power via the first and second rails and converting the first DC power to a first pulsed DC voltage for delivery to at least a first anodeless electrode of a plasma processing chamber; and
- a voltage-boosting circuit coupled between the first and second rails, the voltage-boosting circuit comprising:
 - a first diode coupled between the first rail and a first electrical node, an anode of the first diode being at a voltage of the first rail;
 - a voltage multiplier coupled between the first electrical node and the second rail;
 - a current limiter coupled between the first rail and a second electrical node;
 - a first switch selectively coupling the first electrical node and a second electrical node; and
 - a second diode coupled between the second rail and the second electrical node, an anode of the second diode being at a voltage of the second rail.

2. The pulsed DC power supply system of claim 1, further comprising a third diode having an anode coupled to the second electrical node and a cathode coupled to the first electrical node, the third diode coupled in parallel with the first switch.

3. The pulsed DC power supply system of claim 1, wherein the voltage multiplier includes a capacitive element coupled between the first electrical node and the second rail.

4. The pulsed DC power supply system of claim 3, wherein the voltage multiplier includes two capacitive elements arranged to charge in series and discharge in parallel.

5. The pulsed DC power supply system of claim 4, wherein the voltage multiplier has two outputs: one coupled to the first electrical node; and one coupled to a second inductive element, the second inductive element coupled between the voltage multiplier and a third electrical node.

6. The pulsed DC power supply system of claim 4, wherein a first of the two capacitive elements is arranged to discharge through the first switch and the current limiter and the second of the two capacitive elements is arranged to discharge through (1) one of the outputs of the voltage multiplier, (2) the second inductive element, and (3) the second diode.

7. The pulsed DC power supply system of claim 4, wherein the voltage multiplier further includes at least a third and a fourth diode, the third diode coupled between the first and second capacitive elements, and wherein the fourth diode is arranged between the second rail and the third diode such that a cathode of the fourth diode is at a voltage of an anode of the third diode.

8. The pulsed DC power supply system of claim 5, wherein a controller closes the first switch when the controller determines that a voltage between the first and second rails has reached or exceeded a first threshold, V_{max} , and opens the first switch when the controller determines that the voltage between the first and second rails has reached or fallen below a second threshold, V_{min} .

9. The pulsed DC power supply system of claim 5, further comprising a second switch selectively coupling the second rail and the third electrical node.

10. The pulsed DC power supply system of claim 9, further comprising a voltage sensor coupled across the second of the two capacitive elements, wherein the second switch has a duty cycle that is a function of a voltage across the second of the two capacitive elements as measured by the voltage sensor.

11. The pulsed DC power supply system of claim 1, wherein the voltage-boosting circuit is part of a DC power supply coupled to and providing a first DC power to the first and second rails, such that a rail voltage exists across the first and second rails.

12. The pulsed DC power supply system of claim 1, wherein the voltage-boosting circuit is part of the switching circuit.

13. The pulsed DC power supply system of claim 1, wherein the first switch is selected from the group consisting of: insulated-gate bipolar transistors (IGBTs), bipolar junction transistors, and field effect transistors.

14. The pulsed DC power supply system of claim 1, wherein the voltage-boosting circuit increases a rail voltage V_{AB} between the first and second rails by at least a factor of two when an impedance of a plasma load of the plasma substantially decreases.

15. A pulsed DC power supply system configured to provide pulsed DC power to a plurality of anodeless electrodes of a plasma processing chamber, the pulsed DC power supply comprising:

- a DC power supply coupled to and providing a first DC power to a first and second rail, such that a rail voltage exists across the first and second rails;
- a voltage-boosting circuit coupled between the first and second rails, the voltage-boosting circuit comprising:
 - a first diode coupled between the first rail and a first electrical node, an anode of the first diode being at a voltage of the first rail;
 - a voltage multiplier coupled between the first electrical node and the second rail;
 - a current limiter coupled between the first rail and a second electrical node;
 - a first switch selectively coupling the first electrical node and a second electrical node; and
 - a second diode coupled between the second rail and the second electrical node, an anode of the second diode being at a voltage of the second rail.

16. The pulsed DC power supply system of claim 15, further comprising a switching circuit coupled to the first and second rails and receiving the first DC power via the first and second rails and converting the first DC power to a first pulsed DC voltage configured for delivery to at least a first anodeless electrode of the plasma processing chamber.

17. The pulsed DC power supply system of claim 15, further comprising a third diode having an anode coupled to the second electrical node and a cathode coupled to the first electrical node, the third diode coupled in parallel with the first switch.

18. The pulsed DC power supply system of claim 15, wherein the voltage multiplier includes a capacitive element coupled between the first electrical node and the second rail.

19. The pulsed DC power supply system of claim 18, wherein the voltage multiplier includes two capacitive elements arranged to charge in series and discharge in parallel.

20. The pulsed DC power supply system of claim 19, wherein the voltage multiplier has two outputs: one coupled to the first electrical node; and one coupled to a second

27

inductive element, the second inductive element coupled between the voltage multiplier and a third electrical node.

21. The pulsed DC power supply system of claim 19, wherein a first of the two capacitive elements is arranged to discharge through the first switch and the current limiter and the second of the two capacitive elements is arranged to discharge through (1) one of the outputs of the voltage multiplier, (2) the second inductive element, and (3) the second diode.

22. The pulsed DC power supply system of claim 19, wherein the voltage multiplier further includes at least a third and a fourth diode, the third diode coupled between the first and second capacitive elements, and wherein the fourth diode is arranged between the second rail and the third diode such that a cathode of the fourth diode is at a voltage of an anode of the third diode.

23. The pulsed DC power supply system of claim 20, wherein a controller closes the first switch when the controller determines that a voltage between the first and second rails has reached or exceeded a first threshold, V_{max} , and opens the first switch when the controller determines that the voltage between the first and second rails has reached or fallen below a second threshold, V_{min} .

24. The pulsed DC power supply system of claim 20, further comprising a second switch selectively coupling the second rail and the third electrical node.

25. The pulsed DC power supply system of claim 24, further comprising a voltage sensor coupled across the second of the two capacitive elements, wherein the second switch has a duty cycle that is a function of a voltage across the second of the two capacitive elements as measured by the voltage sensor.

26. The pulsed DC power supply system of claim 15, wherein the voltage-boosting circuit is part of the DC power supply.

27. The pulsed DC power supply system of claim 16, wherein the voltage-boosting circuit is part of the switching circuit.

28. The pulsed DC power supply system of claim 15, wherein the first switch is selected from the group consisting of: insulated-gate bipolar transistors (IGBTs), bipolar junction transistors, and field effect transistors.

28

29. The pulsed DC power supply system of claim 15, wherein the voltage-boosting circuit increases a rail voltage V_{AB} between the first and second rails by at least a factor of two when an impedance of a plasma load of the plasma substantially decreases.

30. A method of operating a voltage-boosting circuit arranged between a first and second rail carrying DC current to a switching circuit that converts DC current on the first and second rails to a pulsed DC voltage and provides the pulsed DC voltage across a plasma load of a plasma processing chamber, the method comprising:

providing a voltage-boosting circuit coupled between the first and second rails, the voltage-boosting circuit comprising:

a first diode coupled between the first rail and a first electrical node, an anode of the first diode being at a voltage of the first rail;

a voltage multiplier coupled between the first electrical node and the second rail;

a current limiter coupled between the first rail and a second electrical node;

a first switch selectively coupling the first electrical node and a second electrical node; and

a second diode coupled between the second rail and the second electrical node, an anode of the second diode being at a voltage of the second rail; and

maintaining the switch in an off state until charging of the capacitive element causes a voltage across the capacitive element to be at least twice a process voltage for the plasma.

31. The method of claim 30, further comprising turning the switch to an off state and discharging the capacitive element through the switch and the current limiter until a voltage between the first and second rails fall below a voltage needed to forward bias the first diode.

32. The method of claim 31, further comprising maintaining the switch in the off state until the switching circuit alters the polarity of the pulsed DC voltage and the first diode is forward biased.

* * * * *