



US009532096B2

(12) **United States Patent**  
**Panje**

(10) **Patent No.:** **US 9,532,096 B2**  
(45) **Date of Patent:** **Dec. 27, 2016**

(54) **SYSTEM AND METHOD FOR SYNCHING PORTABLE MEDIA PLAYER CONTENT WITH STORAGE SPACE OPTIMIZATION**

(58) **Field of Classification Search**  
CPC ..... G06F 12/12; G06F 12/121; G06F 3/005; H04N 21/41407; H04N 21/4126; H04N 1/21; H04N 21/4335  
USPC ..... 711/170, 154  
See application file for complete search history.

(71) Applicant: **Google Technology Holdings LLC**,  
Mountain View, CA (US)

(72) Inventor: **Krishna Prasad Panje**, Bangalore (IN)

(56) **References Cited**

(73) Assignee: **Google Technology Holdings LLC**,  
Mountain View, CA (US)

U.S. PATENT DOCUMENTS

(\*) Notice: Subject to any disclaimer, the term of this patent is extended or adjusted under 35 U.S.C. 154(b) by 0 days.

4,677,501 A \* 6/1987 Saltzman ..... C09B 5/04  
360/137  
4,688,117 A \* 8/1987 Dwyer ..... G11B 27/107  
360/137

(Continued)

(21) Appl. No.: **14/919,174**

FOREIGN PATENT DOCUMENTS

(22) Filed: **Oct. 21, 2015**

GB 2 174 835 A \* 11/1986 ..... G11B 27/34

(65) **Prior Publication Data**

US 2016/0044363 A1 Feb. 11, 2016

*Primary Examiner* — Pierre-Michel Bataille

(74) *Attorney, Agent, or Firm* — Byrne Poh LLP

**Related U.S. Application Data**

(57) **ABSTRACT**

(63) Continuation of application No. 14/570,511, filed on Dec. 15, 2014, now Pat. No. 9,197,923, which is a (Continued)

A device is provided for use with a content provider that is operable to provide content, which includes a plurality of content components. The device includes a communication portion, a memory portion, a parsing portion, a counting portion and a processing portion. The communication portion can receive the content from the content provider. The parsing portion can parse the content into the plurality of content components and can store the parsed plurality of content components within the memory portion. The counting portion can provide a counter for each of the parsed plurality of content components within the memory portion, respectively. The processing portion can retrieve and process one of the parsed plurality of content components within the memory portion. The counting portion can further increment the counter associated with the retrieved one of the parsed plurality of content components within the memory portion.

(51) **Int. Cl.**  
**G06F 12/12** (2016.01)  
**H04N 21/414** (2011.01)  
(Continued)

(52) **U.S. Cl.**  
CPC ..... **H04N 21/41407** (2013.01); **G06F 3/00** (2013.01); **H04L 67/20** (2013.01); **H04N 1/21** (2013.01); **H04N 21/4126** (2013.01); **H04N 21/4302** (2013.01); **H04N 21/435** (2013.01); **H04N 21/439** (2013.01); **H04N 21/4335** (2013.01); **H04N 21/44** (2013.01);  
(Continued)

**12 Claims, 5 Drawing Sheets**

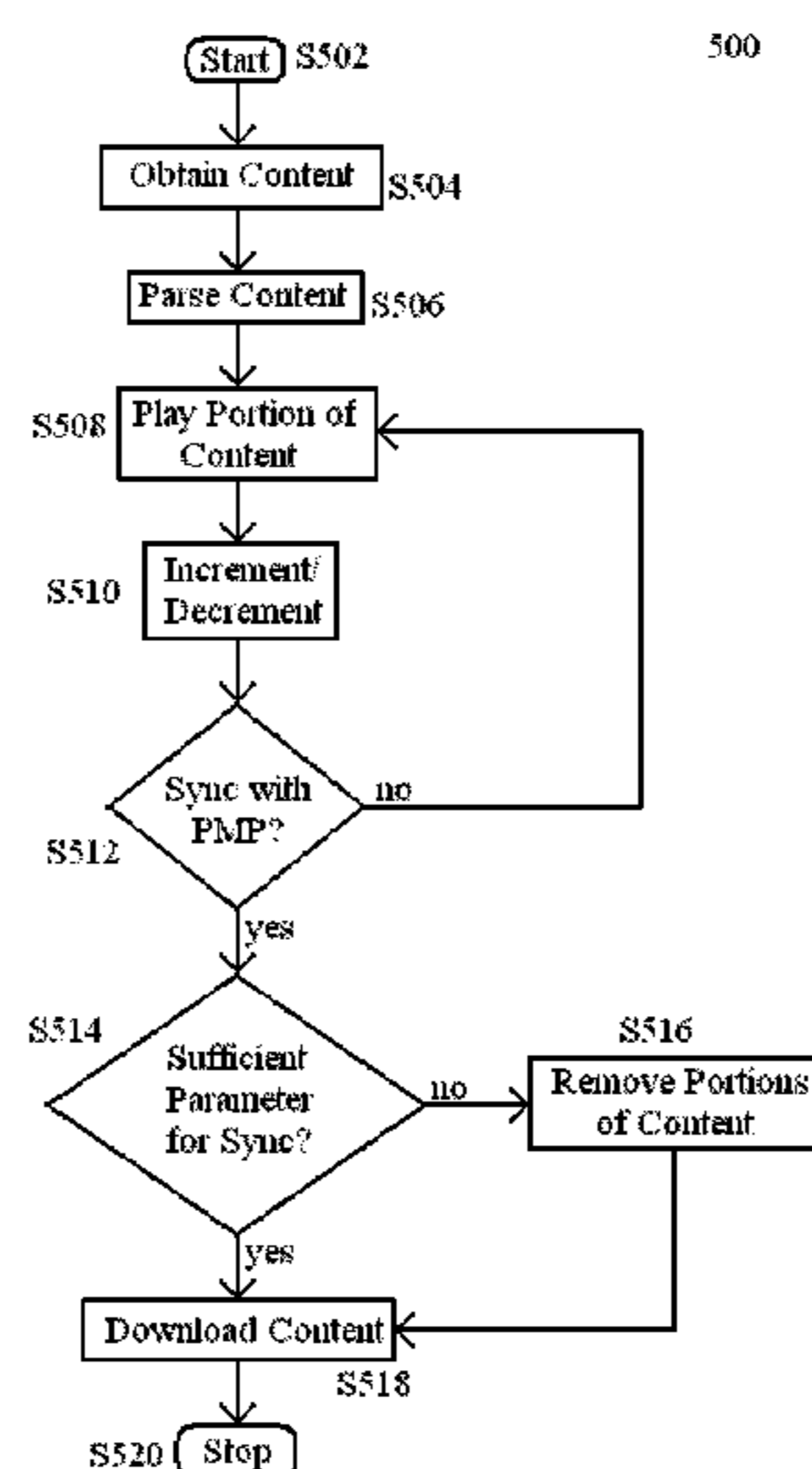

**Related U.S. Application Data**

continuation of application No. 12/847,035, filed on Jul. 30, 2010, now Pat. No. 8,914,603.

(51) **Int. Cl.**

*H04N 1/21* (2006.01)  
*H04L 29/08* (2006.01)  
*H04N 21/41* (2011.01)  
*H04N 21/4335* (2011.01)  
*H04N 21/442* (2011.01)  
*H04N 21/43* (2011.01)  
*H04N 21/435* (2011.01)  
*H04N 21/439* (2011.01)  
*H04N 21/44* (2011.01)  
*G06F 3/00* (2006.01)

(52) **U.S. Cl.**

CPC ..... *H04N 21/44222* (2013.01); *G06F 3/005*  
(2013.01); *G06F 12/121* (2013.01)

(56)

**References Cited**

U.S. PATENT DOCUMENTS

6,628,890 B1 \* 9/2003 Yamamoto ..... H04N 7/16  
348/E7.054  
2004/0052502 A1 \* 3/2004 Komatsu ..... G11B 20/10  
386/241  
2004/0167890 A1 \* 8/2004 Eyal ..... G06F 17/30864  
2005/0135785 A1 \* 6/2005 Kim ..... G11B 27/105  
386/244  
2010/0142915 A1 \* 6/2010 McDermott ..... G11B 27/034  
386/343

\* cited by examiner

FIG. 1

100

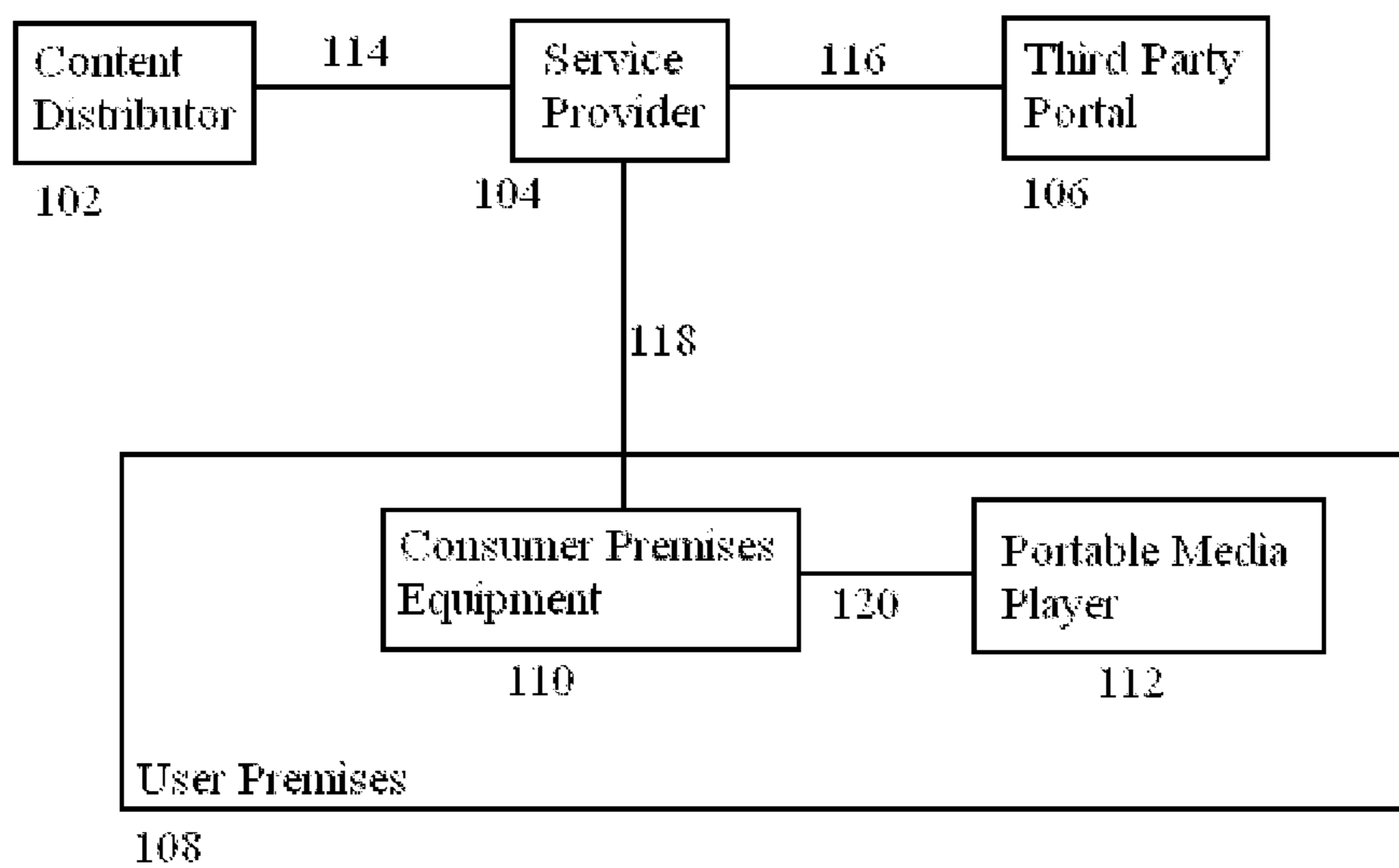

FIG. 2

200

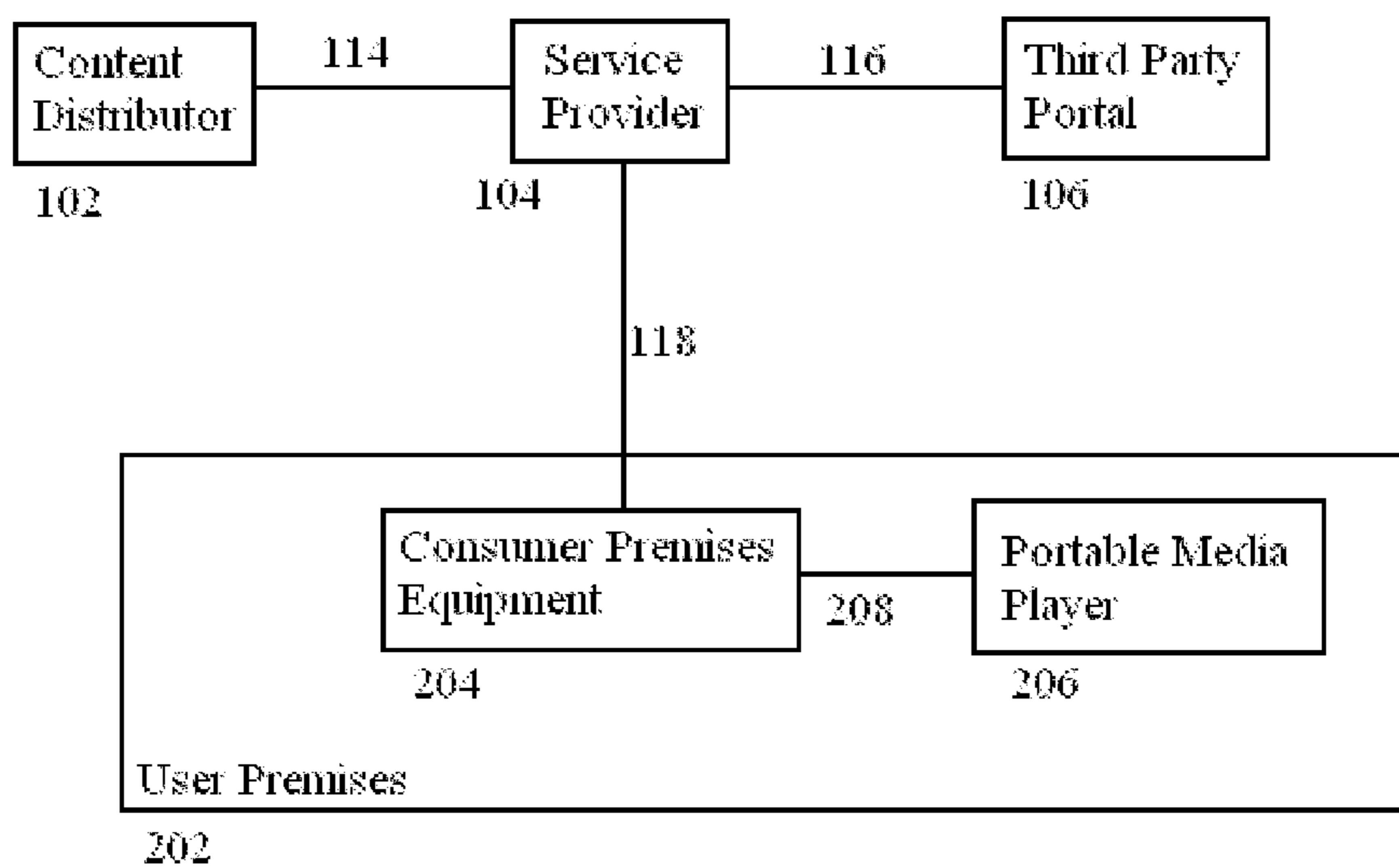

FIG. 3

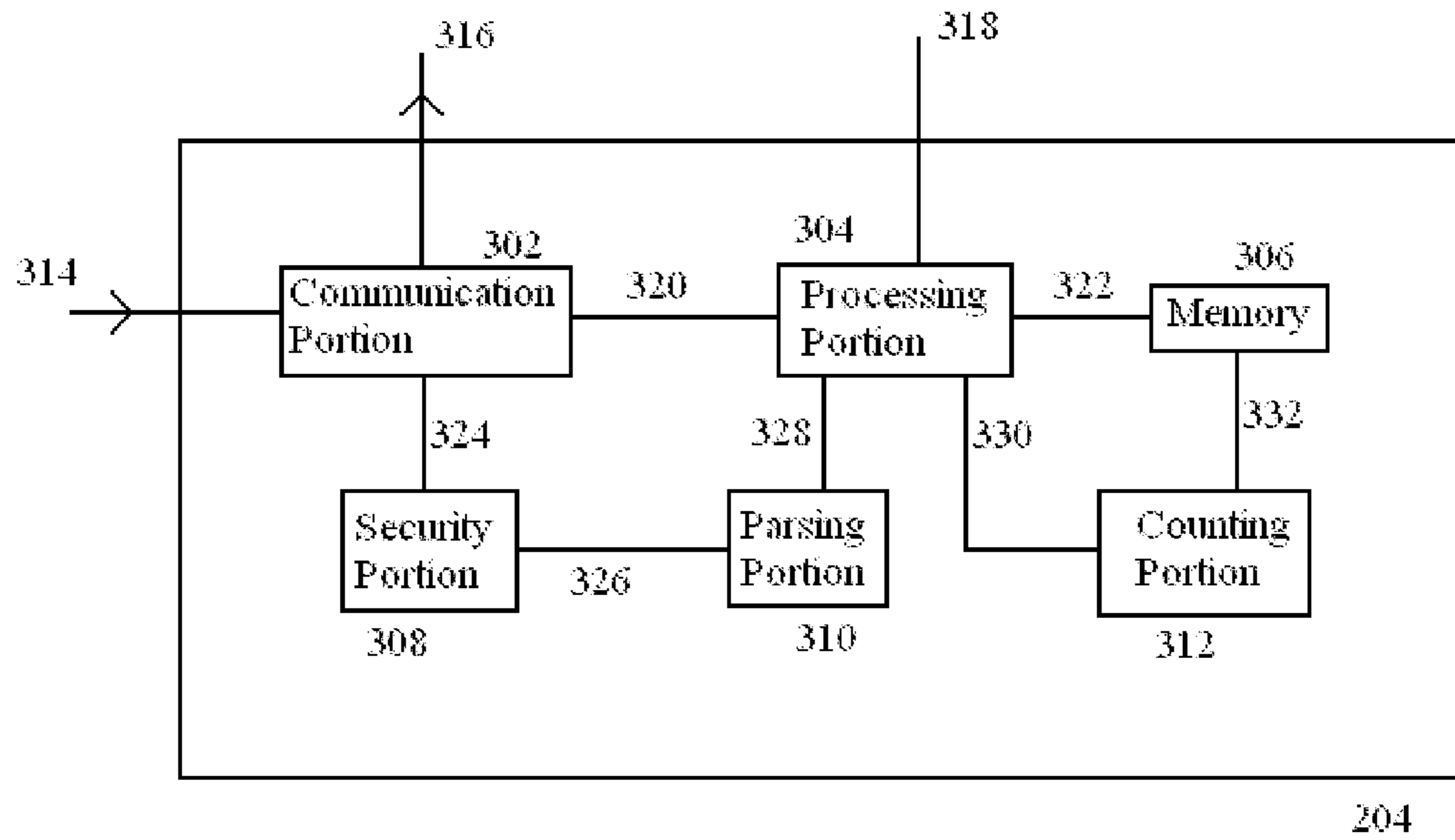

FIG. 4

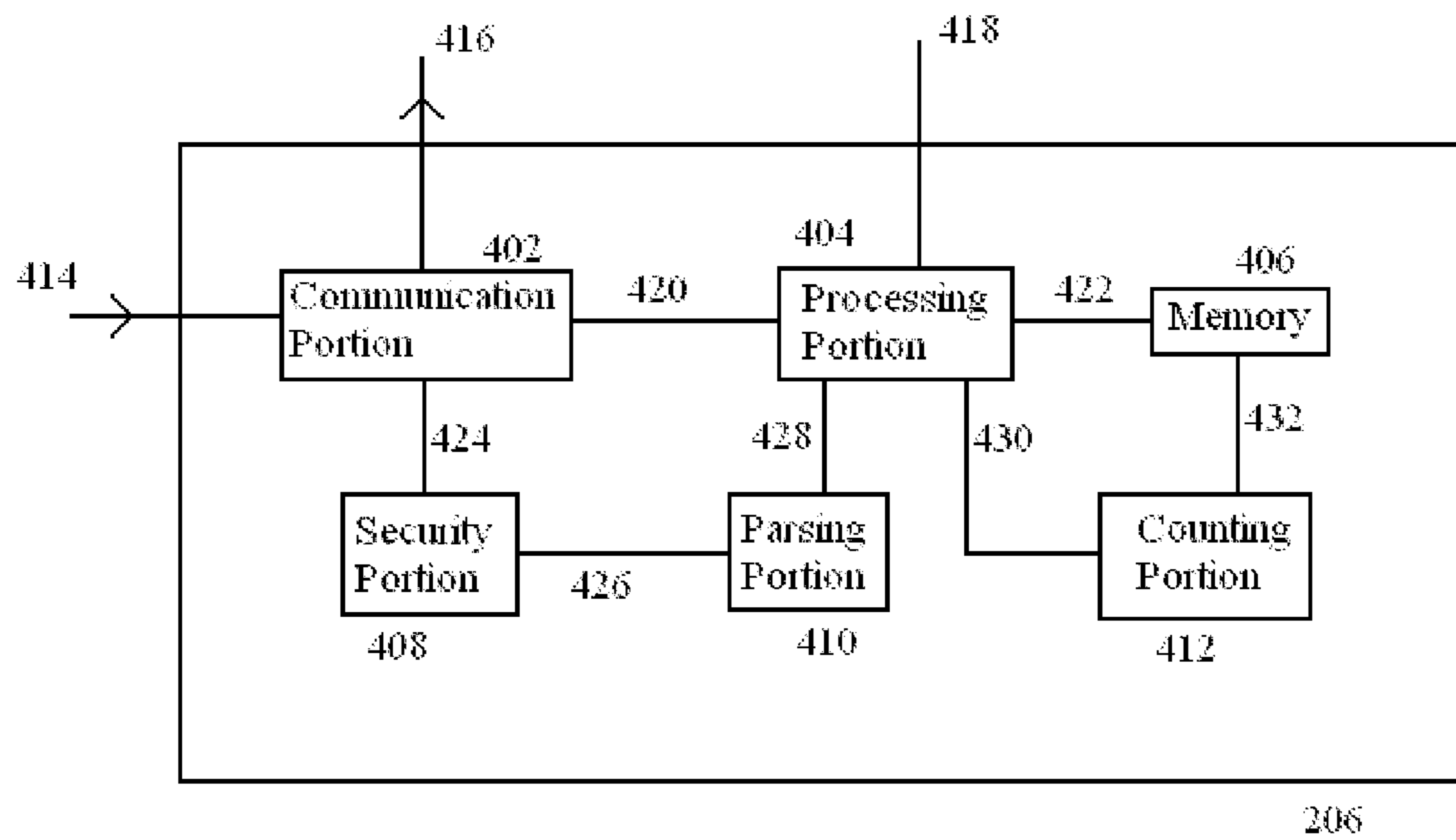

FIG. 5

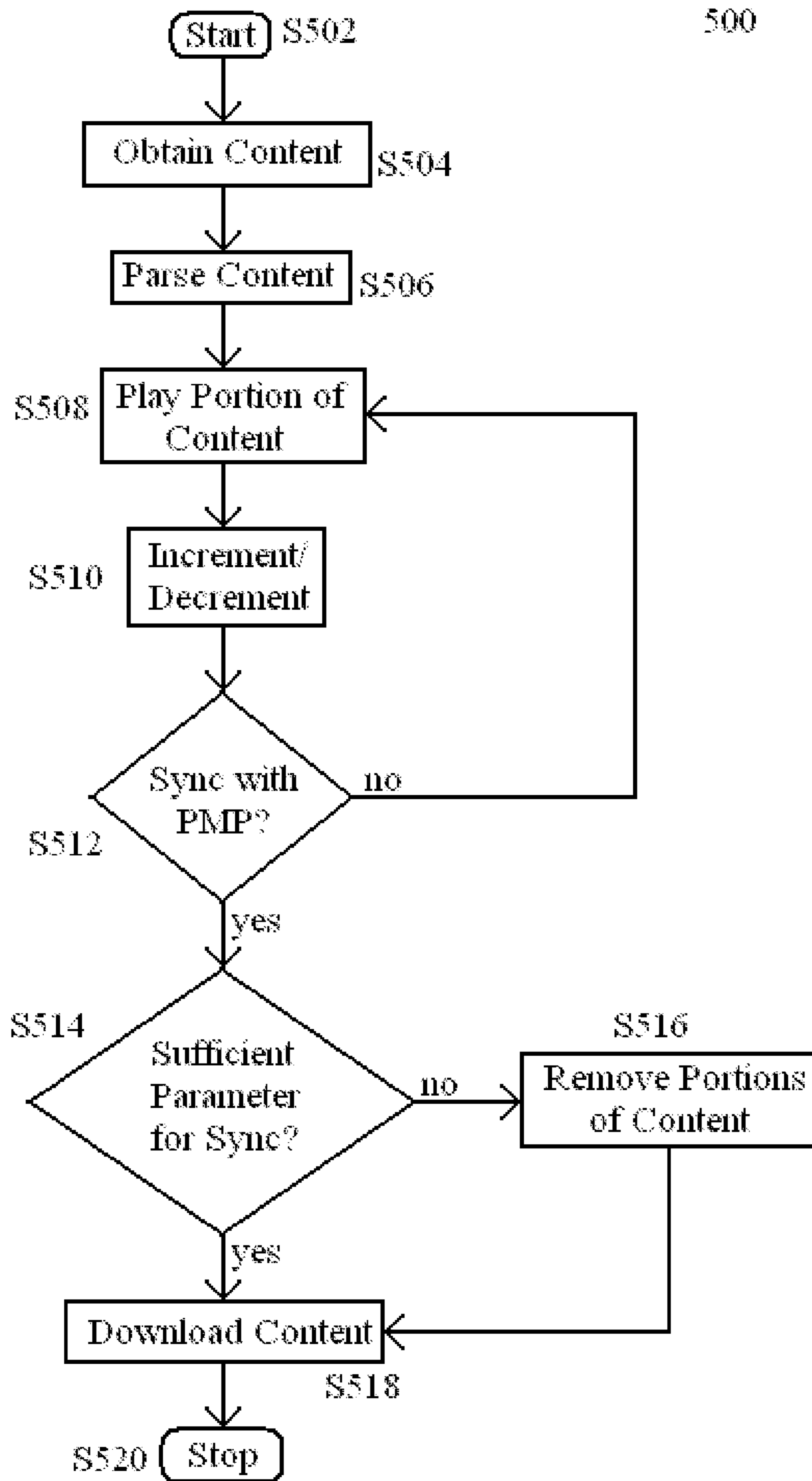

FIG. 6

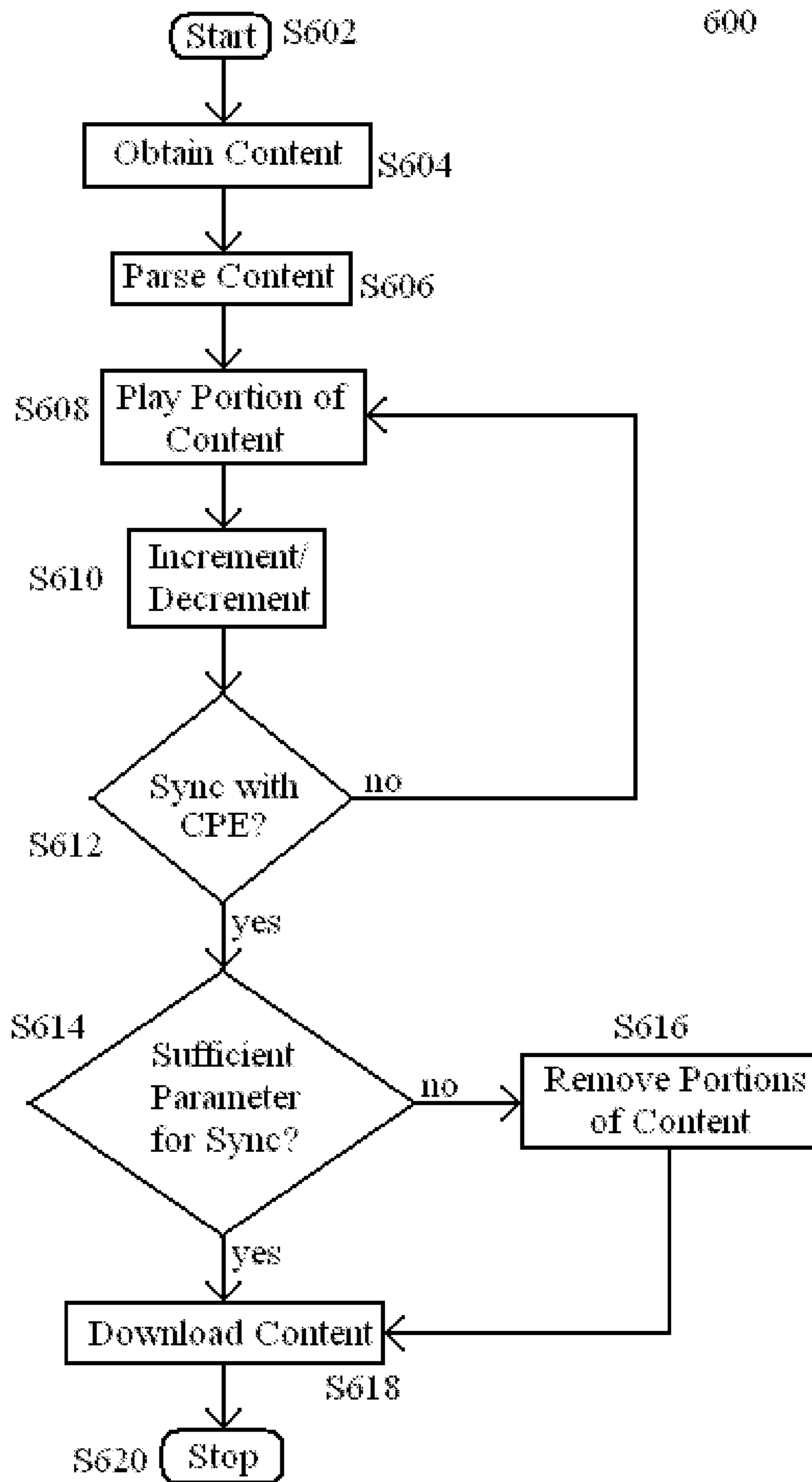
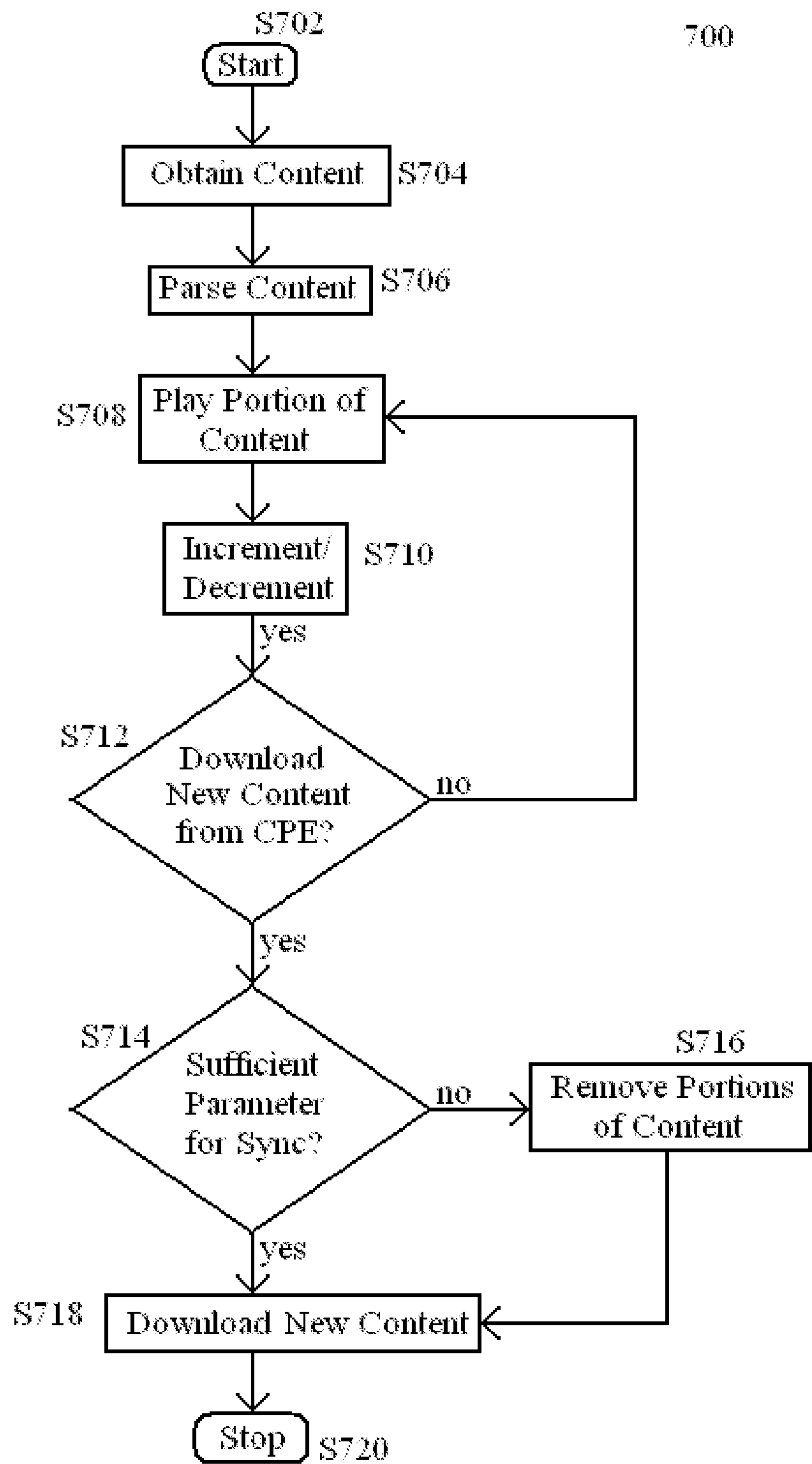

FIG. 7



# SYSTEM AND METHOD FOR SYNCHING PORTABLE MEDIA PLAYER CONTENT WITH STORAGE SPACE OPTIMIZATION

## CROSS REFERENCE TO RELATED APPLICATION

This application is a continuation of U.S. patent application Ser. No. 14/570,511, filed Dec. 15, 2014, now U.S. Pat. No. 9,197,923, which is a continuation of U.S. patent application Ser. No. 12/847,035, filed Jul. 30, 2010, now U.S. Pat. No. 8,914,603, each of which is hereby incorporated by reference herein in its entirety.

## BACKGROUND

With the advent of Digital TV (DTV), the Digital Video Recorder (DVR) and media delivery systems like Internet Protocol TV (IP-TV), and video-on-demand (VOD); viewing content has become very flexible. A user may record a show and watch it later at his convenience. Current DVRs come with large enough storage to store several hours of content.

However, users want to be able to enjoy media content on the move. Portable Media Player (PMP) support for consumer premises equipment (CPE) like DVRs and digital set-top-boxes (STB) allows for mobile viewing of media content. With this feature, users can connect a PMP to a CPE and can choose the content to be transferred to the PMP to be viewed at later instance. Transferring content from a CPE to a PMP may include determining specific viewing or copying rights, authenticating such rights, encrypting/decrypting the content and so on. Such transferring may be referred to as synchronizing or syncing. In use, a user will select content to be transferred to the PMP and the CPE will sync the entire transport stream (TS) associated with that content. The user may then select the content to be displayed on the PMP.

FIG. 1 illustrates an example conventional content distribution system capable of delivering media content from a service provider to an end user.

As illustrated in the figure, content distribution system 100 includes a content distributor 102, a service provider 104, a third party portal 106 and a user premises 108. User premises 108 includes CPE 110 and a PMP 112.

Content distributor 102 is capable of transmitting media content to service provider 104 by way of a signal 114. Third party portal 106 is capable of transmitting media content to service provider 104 by way of a signal 116. Service provider 104 is capable of transmitting media content to CPE 110 of user premises 108 by way of a signal 118. CPE 110 is capable of transmitting media content to PMP 112 by way of a signal 120.

In operation, service provider 104 receives media content by way of signal 114 from content distributor 102 or by way of signal 116 from third party portal 106. Service provider then transmits the media content to CPE 110 by way of signal 118. A user may also decide to transfer media content to PMP 112 by way of signal 120. Some types of media content require a large amount of memory for storage on either CPE 110 or PMP 112, requiring a user to frequently manage the media content stored on PMP 112.

Several problems associated with this method of content transfer from CPE to PMP will now be described.

If The PMP memory (not shown) becomes full the user is then prompted to delete old or specified content. It would be advantageous if the deletion were done automatically. With

the advent of huge content repository and management systems the content is becoming more data intensive. It is not only the format of the content (like space hogging HD video) but also content that may have a plurality of associated information, non-limiting examples of which include different language audio, subtitles, camera angle, director's cut/special, commentary and alternative targeted content.

A user may ask to sync a content to PMP when the PMP may not have space to copy the new content. The user must then browse through the PMP interface and specify distinct portions of content for deletion, one by one. This process may be time consuming and aggravating as the PMP user interface is small and it may be difficult for the user to search through the memory of the PMP.

A user may schedule recordings to record content from an CPE to a PMP. If the scheduled recording requires more memory than available on the PMP, then recording may fail.

When a DVR records a program, the DVR may record the entire transport stream (TS) associated with that program. Different components in the TS are identified with different program identification numbers (PIDs). When a user uses the DVR for playback, specific components of the TS can be presented to the user based on user choice, non-limiting examples of which include audio language and camera angle. The disadvantage of recording the entire TS is that the recording uses a large amount of memory. If the recording is transferred to a PMP, a large amount of PMP memory will be used to store the recording even if there are components of the recording that may never be used on the PMP.

What is needed is a system and method for managing media content on a PMP based on user tendencies.

## BRIEF SUMMARY

The present invention provides a system and method for managing media content on a PMP based on user tendencies.

In accordance with an aspect of the present invention, a device is provided for use by a content provider that is operable to provide content, which includes a plurality of content components. The device includes a communication portion, a memory portion, a parsing portion, a counting portion and a processing portion. The communication portion can receive the content from the content provider. The parsing portion can parse the content into the plurality of content components and can store the parsed plurality of content components within the memory portion. The counting portion can provide a counter for each of the parsed plurality of content components within the memory portion, respectively. The processing portion can retrieve and process one of the parsed plurality of content components within the memory portion. The counting portion can further increment the counter associated with the retrieved one of the parsed plurality of content components within the memory portion.

Additional advantages and novel features of the invention are set forth in part in the description which follows, and in part will become apparent to those skilled in the art upon examination of the following or may be learned by practice of the invention. The advantages of the invention may be realized and attained by means of the instrumentalities and combinations particularly pointed out in the appended claims.

## BRIEF SUMMARY OF THE DRAWINGS

The accompanying drawings, which are incorporated in and form a part of the specification, illustrate an exemplary



embodiment of the present invention and, together with the description, serve to explain the principles of the invention. In the drawings:

FIG. 1 illustrates an example content distribution system;

FIG. 2 illustrates an example content distribution system in accordance with an aspect of the present invention;

FIG. 3 illustrates an example CPE;

FIG. 4 illustrates an example PMP;

FIG. 5 illustrates an example method for a CPE to synchronize with a PMP in accordance with an aspect of the present invention;

FIG. 6 illustrates an example method for a PMP to synchronize with a CPE in accordance with an aspect of the present invention; and

FIG. 7 illustrates an example method for a PMP to synchronize with a CPE in accordance with an aspect of the present invention.

#### DETAILED DESCRIPTION

In one embodiment of the present invention, a user may view media content on a PMP or consumer premises equipment (CPE). The media content may be divided into separate components identified by program identification numbers (PIDs) including but not limited to different video components, different audio components, and data components as in Table 1.

TABLE 1

Program ID	Program->PID ID	Component explanation
0x1234	0x0001	Main video
	0x0002	Main Audio
	0x0003	Spanish audio
	0x0004	Subtitle
	0x0005	Scene description metadata
	0x0006	Targeted video 1
	0x0007	Targeted audio 1
	0x0008	Camera close up video1
	0x0009	Camera close up video2

The “Program ID” column in Table 1 indicates with which program the content is associated. In this example, there is only a single program identified at 0x1234. The “Program->PID ID” column in Table 1 indicates the program identifiers for each component of content within the program. The “Component explanation” column in Table 1 provides an explanation of each component within the program. In this example, the program has nine distinct components: a main video, a main audio, a Spanish audio, a subtitle, a scene description metadata, a targeted video 1, a targeted audio 1, a camera close up video 1 and a camera close up video 2.

When the media content is played back, not all of the PIDs are used at once. For example, a user may decide to play media content on a PMP. The user may decide to watch the main video component (0x0001) with the main audio component (0x0002) and subtitles (0x0004). In this instance, only the components the user needs to watch are required for playback.

In one embodiment of the present invention, a PMP or CPE that is used for playback of media content will associate a play count with the components of the media content that is played on the device. In one example, a user may playback content on a PMP as above. The PMP will then examine the play count of the components of the media content and increment the components that are viewed and decrement the components that are not viewed. In this example, the user

views components with PIDs 0x0001, 0x0002 and 0x0004 but not the other components. In this example, the user is viewing this content for the first time and the play counts of all components are 0. In this example, once the user views the media content, the PMP increments components with PIDs 0x0001, 0x0002 and 0x0004 and decrements the components with PIDs 0x0003, 0x0005, 0x0006, 0x0007, 0x0008 and 0x0009. In other examples, the PMP may alternatively increments components that are played, but not decrement components that are not played.

Over time, a user will view content several times and may choose to view different components each time the content is viewed. For purposes of explanation, presume that after a time period, the user will have viewed the content several times such that play counts associated with the components of the media content are as shown in Table 2.

TABLE 2

Program ID	Program->PID ID	Program->PID Playcount	Component explanation
0x1234	0x0001	6	Main video
	0x0002	6	Main Audio
	0x0003	-6	Spanish audio
	0x0004	6	Subtitle
	0x0005	-6	Scene description metadata
	0x0006	-5	Targeted video 1
	0x0007	-5	Targeted audio 1
	0x0008	-3	Camera close up video1
	0x0009	-3	Camera close up video2

Table 2 is similar to Table 1, but further includes a “Program->PID Playcount” column that indicates a playcount for each component of content within the program. For example, in some embodiments, every time a component of content within the program is played, is it incremented by a predetermined amount. In some embodiments, every time a component of content within the program is played all other components of content within the program that are not played are decremented by a predetermined amount. For purposes of explanation, in this example: the Main video, the Main audio and the subtitle components are played the most, thus receiving a playcount of 6; whereas the Spanish audio and the Scene description metadata components are played the least, thus receiving a playcount of -6.

In one embodiment of the present invention, the PMP is operable to manage its memory based on usage of media content on the PMP. The PMP may examine the play counts associated with components of media content to determine components that can be removed. In one example, a user may decide to synchronize content between a PMP and a CPE. If more memory is needed for synchronization between the PMP and a CPE, the PMP may remove some components of the content. In some embodiments, the PMP may remove the least used components of the content, i.e., the components having the lowest play count, on the device. In some embodiments, the PMP may remove components of the content that are not played a predetermined number of times, i.e., the components having a play count below a predetermined threshold, on the device.

In this example, media content on the PMP is separated into components with play counts as in Table 2. When the PMP needs more memory when synchronizing, the PMP will examine the play counts in the media content. The PMP will then remove the components with the lowest play counts, in this example, components with PIDs 0x0003 and 0x0005 will be removed first. If this removal results in enough available memory for the synchronization process,

the PMP and CPE synchronize. If there is not enough available memory, the PMP may again remove the components of the media content with the lowest play count. In this example, the next components to be removed would be the components with PIDs 0x0006 and 0x0007.

An example system and method for efficiently synchronizing content between CPE and a PMP in accordance with an aspect of the present invention will be described with reference to FIG. 2-7.

FIG. 2 illustrates an example content distribution system 200, in accordance with an aspect of the present invention, which is capable of delivering media content from a service provider to an end user.

As illustrated in FIG. 2, content distribution system 200 includes content distributor 102, service provider 104, third party portal 106 and user premises 202. User premises 202 includes CPE 204 and PMP 206.

Content distributor 102 is capable of transmitting media content to service provider 104 by way of signal 114. Third party portal 106 is capable of transmitting media content to service provider 104 by way of signal 116. Service provider 104 is capable of transmitting media content to CPE 204 of user premises 202 by way of signal 118. CPE 204 is capable of transmitting media content to PMP 206 by way of a signal 208.

Signals 114, 116, 118 and 208 may be wired or wireless signals. Although, each of signals 114, 116, 118 and 208 are illustrated as distinct signals, they all may share a predetermined frequency band within a wireless medium. Signals typically embody computer-readable instructions, data structures, program modules, or other data in a modulated data signal such as a carrier wave or other transport mechanism and include any information-delivery media. Non-limiting examples of communications media, which may carry signals, include wired media, such as wired networks and direct-wired connections, and wireless media such as acoustic, radio, infrared, and other wireless media. The term "computer-readable media" as used herein includes both storage media and communications media.

In operation, service provider 104 receives media content by way of signal 114 from content distributor 102 or by way of signal 116 from third party portal 106. Service provider 104 then transmits the media content to CPE 204 by way of signal 118. A user may also decide to transfer media content to PMP 206 by way of signal 208. In accordance with an aspect of the present invention, media content synchronized between CPE 204 and PMP 206 may be reduced in size to allow for faster synchronization or smaller memory required for storage.

FIG. 3 illustrates a detailed view of an example CPE 204 in accordance with an aspect of the present invention.

As illustrated in FIG. 3, CPE 204 includes a communication portion 302, a processing portion 304, a memory 306, a security portion 308, a parsing portion 310 and a counting portion 312. In this example, each of communication portion 302, processing portion 304, memory 306, security portion 308, parsing portion 310 and counting portion 312 are distinct devices. However, in other embodiments, at least two of communication portion 302, processing portion 304, memory 306, security portion 308, parsing portion 310 and counting portion 312 may be combined as a unitary device. Further, in some embodiments at least one of communication portion 302, processing portion 304, memory 306, security portion 308, parsing portion 310 and counting portion 312 may be implemented as computer-readable media for carrying or having computer-executable instructions or data structures stored thereon. Such computer-

readable media can be any available media that can be accessed by a general purpose or special purpose computer. Non-limiting examples of computer-readable media include physical storage and/or memory media such as RAM, ROM, EEPROM, CD-ROM or other optical disk storage, magnetic disk storage or other magnetic storage devices, or any other medium which can be used to carry or store desired program code means in the form of computer-executable instructions or data structures and which can be accessed by a general purpose or special purpose computer. When information is transferred or provided over a network or another communications connection (either hardwired, wireless, or a combination of hardwired or wireless) to a computer, the computer properly views the connection as a computer-readable medium. Thus, any such connection is properly termed a computer-readable medium. Combinations of the above should also be included within the scope of computer-readable media.

Communication portion 302 is capable of receiving input by way of a signal 314 and capable of transmitting output by way of a signal 316. Additionally, communication portion 302 is capable of exchanging data with security portion 308 by way of a signal 324 and is capable of exchanging data with processing portion 304 by way of a signal 320. Processing portion 304 is capable of outputting to a display by way of a signal 318. Additionally, processing portion 304 is capable of communicating with memory 306 by way of a signal 322, is capable of communicating with parsing portion 310 by way of a signal 328 and is capable of communicating with counting portion 312 by way of a signal 330. Memory portion 306 is capable of communicating with counting portion 312 by way of a signal 332. Security portion 308 is capable of communicating with parsing portion 310 by way of a signal 326.

Signals 316, 318, 320, 322, 324, 326, 328, 330 and 332 may be wired or wireless signals. Although, each of signals 316, 318, 320, 322, 324, 326, 328, 330 and 332 are illustrated as distinct signals, they all may share a predetermined frequency band within a wireless medium. Signals typically embody computer-readable instructions, data structures, program modules, or other data in a modulated data signal such as a carrier wave or other transport mechanism and include any information-delivery media. Non-limiting examples of communications media, which may carry signals, include wired media, such as wired networks and direct-wired connections, and wireless media such as acoustic, radio, infrared, and other wireless media.

Communication portion 302 is used to communicate with external devices such as PMP 206 through known protocols, non-limiting examples of which include Wi-Fi and USB. Communication portion 302 may also communicate with external media sources such as service provider 104 through known protocols, non-limiting examples of which include cable, satellite, fiber-optic communication.

Processing portion 304 is used for control of communication portion 302, memory 306, parsing portion 310 and counting portion 312. Processing portion 304 is also capable of outputting video to a display by way of signal 318 in known formats, non-limiting examples of which include MPEG-1, MPEG-2 and MPEG-4.

Memory 306 is used for storage of media content and other information as required by CPE 204.

Security portion 308 is used to manage the intellectual property rights (IPR) of the media content. Non-limiting examples of IPR may include restrictions on the number of times that media content may be played, restrictions on the number of times that media content may be copied or

transferred, restrictions on devices that media content is allowed to be copied or transferred to, and restrictions on the length of time that media content can be used from when it was first downloaded or first viewed. Security portion 308 may manage the IPR of the media content through use of encryption keys.

Parsing portion 310 is used to separate media content transferred to CPE 204 into separate components. One example of the components of media content is discussed above with reference to Table 1. The media content has multiple video components, multiple audio components and other data. For example, parsing portion 310 can separate components of media content used for playback. A user may wish to view the main video component with the Spanish audio component. Parsing portion 310 separates the main video component and the Spanish audio component of the media content for playback.

Counting portion 312 is used to increment and decrement play counts associated with components of the media content used by CPE 204. In one embodiment of the present invention, when media content is played by CPE 204, counting portion may increment portions of media content that are played and decrement portions of media content that are not played as discussed in the example above.

In one embodiment of the present invention, CPE 204 is capable of receiving media content as input signal 314. Communication portion 302 receives input signal 314 and transmits the media content to security portion 308 by way of signal 324. Security portion 308 decrypts the media content and transmits the decrypted media content to parsing portion 310 by way of signal 326. Parsing portion 310 parses the decrypted media content and transmits the parsed media content to processing portion 304 by way of signal 328. Parsing portion 310 separates the media content into several pieces, non-limiting examples include video, audio and metadata. Processing portion 304 sends the parsed media content to be stored in memory 306 by way of signal 322.

When a user requests playback on CPE 204, processing portion 304 retrieves content from memory 306 by way of signal 322. Processing portion 304 then outputs the content to a display by way of signal 318. The media content being displayed may have more components than can be viewed at once, non-limiting examples of which include multiple video streams, multiple audio streams and multiple camera angles. In one embodiment of the present invention, the pieces of parsed media content are each associated with a counter. When the media content is played by CPE 204, the counters associated with portions of the content that are displayed are incremented while the counters associated with portions of the content that are not displayed are decremented. In this embodiment, processing portion 304 signals counting portion 312 to increment or decrement the counters associated with specific portions of media content by way of signal 330. Counting portion 312 then increments or decrements the counters associated with the media content in memory 306 by way of signal 332.

Additionally, processing portion 304 may request media content from memory 306 by way of signal 322 for output to another device. Processing portion 304 then outputs the media content to communication portion 302 by way of signal 320. Communication portion 302 outputs the media content by way of signal 316.

FIG. 4 illustrates a detailed view of PMP 206 in accordance with an aspect of the present invention.

As illustrated in FIG. 4, PMP 206 includes a communication portion 402, a processing portion 404, a memory 406, a security portion 408, a parsing portion 410 and a counting

portion 412. In this example, each of communication portion 402, processing portion 404, memory 406, security portion 408, parsing portion 410 and counting portion 412 are distinct devices. However, in other embodiments, at least two of communication portion 402, processing portion 404, memory 406, security portion 408, parsing portion 410 and counting portion 412 may be combined as a unitary device. Further, in some embodiments at least one of communication portion 402, processing portion 404, memory 406, security portion 408, parsing portion 410 and counting portion 412 may be implemented as computer-readable media for carrying or having computer-executable instructions or data structures stored thereon.

Communication portion 402 is capable of receiving input by way of a signal 414 and capable of transmitting output by way of a signal 416. Additionally, communication portion 402 is capable of exchanging data with security portion 408 by way of a signal 424 and capable of exchanging data with processing portion 404 by way of a signal 420. Processing portion 404 is capable of outputting to a display (not shown) by way of a signal 418. Additionally, processing portion 404 is capable of communicating with memory 406 by way of a signal 422, is capable of communicating with parsing portion 410 by way of a signal 428, and is capable of communicating with counting portion 412 by way of a signal 430. Memory portion 406 is capable of communicating with counting portion 412 by way of a signal 432. Security portion 408 is capable of communicating with parsing portion 410 by way of a signal 426. Additionally, memory portion 406 of PMP 206 is smaller than memory portion 306 of CPE 204.

Signals 414, 416, 418, 420, 422, 424, 426, 428, 430 and 432 may be wired or wireless signals. Although, each of signals 414, 416, 418, 420, 422, 424, 426, 428, 430 and 432 are illustrated as distinct signals, they all may share a predetermined frequency band within a wireless medium. Signals typically embody computer-readable instructions, data structures, program modules, or other data in a modulated data signal such as a carrier wave or other transport mechanism and include any information-delivery media. Non-limiting examples of communications media, which may carry signals, include wired media, such as wired networks and direct-wired connections, and wireless media such as acoustic, radio, infrared, and other wireless media.

In one embodiment of the present invention, PMP 206 is capable of receiving media content as input signal 414. Communication portion 402 receives input signal 414 and transmits the media content to security portion 408 by way of signal 424. Security portion 408 decrypts the media content and transmits the decrypted media content to parsing portion 410 by way of signal 426. Parsing portion 410 parses the decrypted media content and transmits the parsed media content to processing portion 404 by way of signal 428. Parsing portion 410 separates the media content into several pieces, non-limiting examples of which include video, audio and metadata. Processing portion 404 sends the parsed media content to be stored in memory 406 by way of signal 422.

When a user requests playback on PMP 206, processing portion 404 retrieves content from memory 406 by way of signal 422. Processing portion 404 then outputs the content to a display by way of signal 418. The media content being displayed may have more components than can be viewed at once, non-limiting examples of which include multiple video streams, multiple audio streams and multiple camera angles. In one embodiment of the present invention, the pieces of parsed media content are each associated with a

counter. When the media content is played by PMP 206, the counters associated with portions of the content that are displayed are incremented while the counters associated with portions of the content that are not displayed are decremented. In this embodiment, processing portion 404 signals counting portion 412 to increment or decrement the counters associated with specific portions of media content by way of signal 430. Counting portion 412 then increments or decrements the counters associated with the media content in memory 406 by way of signal 432.

Additionally, processing portion 404 may request media content from memory 406 by way of signal 422 for output to another device. Processing portion 404 then outputs the media content to communication portion 402 by way of signal 420. Communication portion 402 outputs the media content by way of signal 416.

Example methods of transfer of content between CPE 204 and PMP 206 will be described with reference to FIG. 5-7.

FIG. 5 illustrates an example method 500 for CPE 204 to synchronize with PMP 206 in accordance with an aspect of the present invention.

To start (S502), CPE 204 obtains media content (S504) from service provider 104. In one embodiment, processing portion 304 instructs communication portion 302 to request content from service provider 104 by way of signal 316. Service provider 104 then provides the requested content by way of signal 314. In the event the provided content is encrypted, security portion 308 decrypts the content in accordance with the IP rights associated with the content as provided by service provider. The decrypted content is then provided to parsing portion 310.

The media content is then parsed into separate components (S506). For purposes of discussion, presume that CPE 204 downloads movie content corresponding to a movie titled "MOVIE." Further, for purposes of discussion, suppose MOVIE content includes a main video component, a main audio component, a Spanish audio component, a subtitle component, scene description metadata, a targeted video 1 component, a targeted audio 1 component, a camera close up video 1 component and a camera close up video 2 component, for example as discussed above with reference to Table 1. At this point, processing portion 304 instructs parsing portion 310 to separate MOVIE content into its components.

A user may then play portions of content on CPE 204 (S508). As mentioned above, a user may access components of MOVIE content for playback, for example on a TV (not shown).

The portions of the content are then incremented and/or decremented (S510). In one embodiment, counting portion 312 increments counters associated with the portions of the content that are played and decrements the counters associated with the portions of the content that are not played. In another embodiment, counting portion 312 increments counters associated with the portions of the content that are played and does not change the counters associated with the portions of the content that are not played.

It is then determined whether CPE 204 is to be synced with PMP 206 (S512). If content is not to be synced, then the person may continue to play portions of MOVIE content (S508).

If content is to be synced, it is then determine whether there are sufficient parameters for synchronization (S514). Non-limiting examples of synchronization parameters include time required for synchronization and memory available on PMP 206. For example, a user may be attempting to sync all the components of MOVIE content from CPE

204 to PMP 206. In this example, presume that PMP 206 indicates that synchronizing all the components of MOVIE will take 15 minutes and will require 12 gigabytes of storage within PMP 206. At that point, the user may determine that 15 minutes is too long a wait. Similarly, PMP 206 may provide an indication to user that memory portion 406 does not have 12 gigabytes of free storage with which it may download all the components of MOVIE.

If the parameters for synchronization are met, PMP 206 downloads the content from CPE 204 (S518). For example, suppose that PMP 206 indicates that synchronizing all the components of MOVIE will take 15 minutes and will require 12 gigabytes of storage within PMP 206. Further, suppose that the user does not mind waiting 15 minutes and that memory portion 406 of PMP 206 has 12 gigabytes of free storage with which it may download all of the components of MOVIE. In such a case, in one embodiment, processing portion 404 instructs communication portion 402 to request content from CPE 204 by way of signal 416. CPE 204 then provides the requested MOVIE content by way of signal 414. In the event the provided content is encrypted, security portion 408 decrypts the content in accordance with the IP rights associated with the content as provided by service provider. The decrypted content is then provided to parsing portion 410. At this point, processing portion 404 instructs parsing portion 410 to separate MOVIE content into its components.

The process then stops (S520) and the user may then view portions of content on PMP 206.

If the parameters for synchronization are not met, portions of MOVIE content are removed from the syncing process (S516). In an example embodiment, the counters associated with different components of MOVIE content are checked and the portions that have the lowest count are removed from the syncing process, e.g., they are not downloaded from CPE 204 to PMP 206. If not enough content has been removed, the portions with the next lowest counts are removed or deleted. The process of removing the portions of content with the lowest counts is repeated until the parameters for synchronization are met.

It is then again determined whether there are sufficient parameters for synchronization (S514).

Then, PMP 206 downloads the content from CPE 204 (S518) and the process finishes (S520).

The method described in FIG. 5 is drawn to synchronizing content from CPE 204 to PMP 206, wherein if memory 406 of PMP 206 has insufficient space to transfer all the content, some components of the content are not transferred from memory 306 of CPE 204. In another example method, unused portions of stored content within memory 406 of PMP 206 may be deleted to make room for downloading content from CPE 204. Such an example method will be described with reference to FIG. 6.

FIG. 6 illustrates an example method 600 for PMP 206 to synchronize with CPE 204 in accordance with an aspect of the present invention.

Method 600 starts (S602) and PMP 204 obtains media content from CPE 204 (S604). In one embodiment, processing portion 404 instructs communication portion 402 to request content from CPE 204 by way of signal 416. CPE 204 then provides the requested content by way of signal 414. In the event the provided content is encrypted, security portion 408 decrypts the content in accordance with the IP rights associated with the content as provided by service provider. The decrypted content is then provided to parsing portion 410.

The media content is then parsed into separate components, in a manner similar to that described above with reference to step S506 of method 500 (S606). For purposes of discussion, presume that PMP 206 downloads movie content corresponding to a movie titled "MOVIE." Further, for purposes of discussion, suppose MOVIE content includes a main video component, a main audio component, a Spanish audio component, a subtitle component, scene description metadata, a targeted video 1 component, a targeted audio 1 component, a camera close up video 1 component and a camera close up video 2 component, for example as discussed above with reference to Table 1. At this point, processing portion 404 instructs parsing portion 410 to separate MOVIE content into its components.

A user may then play portions of content on PMP 206 (S608). As mentioned above, a user may access components of MOVIE content for playback, for example on a TV (not shown).

The portions of the content are then incremented and/or decremented in a manner similar to step S510 discussed above with reference to method 500 (S610). In one embodiment, counting portion 412 increments counters associated with the portions of the content that are played and decrements the counters associated with the portions of the content that are not played. In another embodiment, counting portion 412 increments counters associated with the portions of the content that are played and does not change the counters associated with the portions of the content that are not played.

It is then determined whether additional content is to be synchronized onto PMP 206 from CPE 204 (S612). For example, the user may want to copy second content.

If a user is not currently trying to synchronize content, then the person may be able to continue to play portions of the content currently on PMP 206 (S608).

If a user is attempting to synchronize content, it is then determined whether there are sufficient parameters for synchronization (S614). Non-limiting examples of synchronization parameters include time required for synchronization and memory available on PMP 206. For example, for purposes of discussion, presume that user want to synchronize, from CPE 204 onto PMP 206, another movie content corresponding to a movie titled "SECOND MOVIE." Further, for purposes of discussion, suppose SECOND MOVIE content includes a main video component, a main audio component, a Spanish audio component, a subtitle component, scene description metadata, a targeted video 1 component, a targeted audio 1 component, a camera close up video 1 component and a camera close up video 2 component, for example as discussed above with reference to Table 1. In this example, presume that PMP 206 indicates that synchronizing all the components of SECOND MOVIE will take 15 minutes and will require 12 gigabytes of storage within PMP 206. At that point, the user may determine that 15 minutes is too long a wait. Similarly, PMP 206 may provide an indication to user that memory portion 406 does not have 12 gigabytes of free storage with which it may download all the components of SECOND MOVIE.

If the parameters for synchronization are met, PMP 206 downloads the content from CPE 204 (S618). For example, suppose that PMP 206 indicates that synchronizing all the components of SECOND MOVIE will take 15 minutes and will require 12 gigabytes of storage within PMP 206. Further, suppose that the user does not mind waiting 15 minutes and that memory portion 406 of PMP 206 has 12 gigabytes of free storage with which it may download all of the components of SECOND MOVIE. In such a case, in one

embodiment, processing portion 404 instructs communication portion 402 to request content from CPE 204 by way of signal 416. CPE 204 then provides the requested MOVIE content by way of signal 414. In the event the provided content is encrypted, security portion 408 decrypts the content in accordance with the IP rights associated with the content as provided by service provider. The decrypted content is then provided to parsing portion 410. At this point, processing portion 404 instructs parsing portion 410 to separate MOVIE content into its components.

If the parameters for synchronization are not met, components of the content currently residing in PMP are deleted (S616). In an example embodiment, the counters associated with different components of MOVIE content are checked and the components that have the lowest count are deleted from memory 406 of PMP 206. If not enough memory has been freed, the components of MOVIE CONTENT with the next lowest counts are deleted. The process of deleting the components of content with the lowest counts is repeated until the parameters for synchronization are met.

Then, PMP 206 downloads the content from CPE 204 (S618) and the process finishes (S620). In this example, the SECOND MOVIE content will be downloaded into PMP 206.

The example system and methods described above with reference to FIG. 6 manage media content between CPE 204 and PMP 206 by removing the least used content components within PMP 206 to free memory within PMP 206. This enables PMP 206 to download additional content that otherwise would not have fit within memory 406 of PMP 206.

Another example system and method in accordance with aspects of the present invention include a combination of the example method discussed above with reference to FIG. 5 and the example method discussed above with reference to FIG. 6. In particular, if the memory of a PMP has insufficient space to transfer all the desired content from a CPE, some components of the desired content may not transferred from the memory of the CPE and some of the components of content within the PMP may be deleted.

In another example method, PMP 206 uses user preferences developed viewing MOVIE CONTENT stored in memory 406 of PMP 206 to remove some components of additional movie content to be transferred from memory 306 of CPE 204. Such an example method will be described with reference to FIG. 7.

FIG. 7 illustrates an example method 700 for PMP 206 to develop user preferences and download new content from CPE 204 in accordance with an aspect of the present invention.

Method 700 starts (S702) and PMP 204 obtains media content from CPE 204 (S704). In one embodiment, processing portion 404 instructs communication portion 402 to request content from CPE 204 by way of signal 416. CPE 204 then provides the requested content by way of signal 414. In the event the provided content is encrypted, security portion 408 decrypts the content in accordance with the IP rights associated with the content as provided by service provider. The decrypted content is then provided to parsing portion 410.

The media content is then parsed into separate components, in a manner similar to that described above with reference to step S506 of method 500 (S706). For purposes of discussion, presume that PMP 206 downloads movie content corresponding to a movie titled "MOVIE." Further, for purposes of discussion, suppose MOVIE content includes a main video component, a main audio component, a Spanish audio component, a subtitle component, scene

description metadata, a targeted video 1 component, a targeted audio 1 component, a camera close up video 1 component and a camera close up video 2 component, for example as discussed above with reference to Table 1. At this point, processing portion 404 instructs parsing portion 410 to separate MOVIE content into its components.

A user may then play portions of content on PMP 206 (S708). As mentioned above, a user may access components of MOVIE content for playback, for example on a TV (not shown).

The portions of the content are then incremented and/or decremented in a manner similar to step S510 discussed above with reference to method 500 (S710). In one embodiment, counting portion 412 increments counters associated with the portions of the content that are played and decrements the counters associated with the portions of the content that are not played. In another embodiment, counting portion 412 increments counters associated with the portions of the content that are played and does not change the counters associated with the portions of the content that are not played.

In another embodiment of the present invention, PMP 206 may periodically transmit the counters associated with MOVIE in memory 406 of PMP 206 to CPE 204. CPE 204 may use the transmitted counters to learn preferences of PMP 206 and accordingly make determinations of which portions of content should be transmitted during future media downloads to PMP 206. This allows PMP 206 and CPE 204 to independently make decisions for memory management.

It is then determined whether additional content is to be synchronized onto PMP 206 from CPE 204 (S712). For example, the user may want to copy second content.

If a user is not currently trying to acquire additional content, then the person may be able to continue to play portions of the content currently on PMP 206 (S708).

If a user is attempting to acquire additional content, it is then determined whether there are sufficient parameters for content transfer (S714). Non-limiting examples of synchronization parameters include time required for synchronization and memory available on PMP 206. For example, for purposes of discussion, presume that user want to synchronize, from CPE 204 onto PMP 206, another movie content corresponding to a movie titled "SECOND MOVIE." Further, for purposes of discussion, suppose SECOND MOVIE content includes a main video component, a main audio component, a Spanish audio component, a subtitle component, scene description metadata, a targeted video 1 component, a targeted audio 1 component, a camera close up video 1 component and a camera close up video 2 component, for example as discussed above with reference to Table 1. In this example, presume that PMP 206 indicates that synchronizing all the components of SECOND MOVIE will take 15 minutes and will require 12 gigabytes of storage within PMP 206. At that point, the user may determine that 15 minutes is too long a wait. Similarly, PMP 206 may provide an indication to user that memory portion 406 does not have 12 gigabytes of free storage with which it may download all the components of SECOND MOVIE.

If the parameters for synchronization are met, PMP 206 downloads the content from CPE 204 (S718). For example, suppose that PMP 206 indicates that synchronizing all the components of SECOND MOVIE will take 15 minutes and will require 12 gigabytes of storage within PMP 206. Further, suppose that the user does not mind waiting 15 minutes and that memory portion 406 of PMP 206 has 12 gigabytes of free storage with which it may download all of the

components of SECOND MOVIE. In such a case, in one embodiment, processing portion 404 instructs communication portion 402 to request content from CPE 204 by way of signal 416. CPE 204 then provides the requested MOVIE content by way of signal 414. In the event the provided content is encrypted, security portion 408 decrypts the content in accordance with the IP rights associated with the content as provided by service provider. The decrypted content is then provided to parsing portion 410. At this point, processing portion 404 instructs parsing portion 410 to separate MOVIE content into its components.

The main advantage of this process of memory management on PMP 206 is efficient storage management of PMP 206, without user intervention. With the example methods described above, PMP 206 is capable of managing memory when transferring media content from CPE 204 to PMP 206 without prompting the user for more input even if there is not enough available memory of PMP 206.

If the parameters for synchronization are not met, components of the content to be transferred are not transferred during synchronization (S716). In an example embodiment, the counters associated with different components of MOVIE content are checked and the components that have the lowest count are used to mark the components of SECOND MOVIE not to transfer from CPE 204 to PMP 206. If not enough memory has been freed, the components of SECOND MOVIE with the next lowest counts are marked not to be transferred. The process of marking the components of content with the lowest counts is repeated until the parameters for synchronization are met.

In another example embodiment, the counters associated with different components of MOVIE content are checked and only the components that have the highest count are used to mark the components of SECOND MOVIE to transfer from CPE 204 to PMP 206.

Then, PMP 206 downloads the content from CPE 204 (S718) and the process finishes (S720). In this example, the SECOND MOVIE content will be downloaded into PMP 206.

The foregoing description of various preferred embodiments of the invention have been presented for purposes of illustration and description. It is not intended to be exhaustive or to limit the invention to the precise forms disclosed, and obviously many modifications and variations are possible in light of the above teaching. The example embodiments, as described above, were chosen and described in order to best explain the principles of the invention and its practical application to thereby enable others skilled in the art to best utilize the invention in various embodiments and with various modifications as are suited to the particular use contemplated. It is intended that the scope of the invention be defined by the claims appended hereto.

What is claimed is:

1. A method for managing media content items, the method comprising:
  - receiving, using a media playback device that includes a hardware processor, media content item as an input signal, wherein the input signal includes a plurality of different content components associated with the media content item;
  - parsing, using the media playback device that includes the hardware processor, the received media content item into the plurality of content components of the media content item;
  - associating, using the media playback device, a counter with each of the plurality of content components, wherein the counter begins at an initial value;

15

receiving, using the media playback device that includes the hardware processor, a request to playback the media content item, wherein the media content item includes a portion of the plurality of content components;

determining, using the media playback device that includes the hardware processor, that at least one content component of the plurality of content components is being played back in response to receiving the request to playback the media content item;

updating, using the media playback device that includes the hardware processor, the counter associated with each of the plurality of content components based on the portion of the plurality of content components that are played back by incrementing a value of the counter associated with the at least one content component from the initial value and decrementing values of the counters associated with the plurality of content components that are not being played back from the initial value; and

in response to receiving a request to playback an additional media content item, determining, using the media playback device that includes the hardware processor, which of the plurality of content components associated with the additional media content item to retrieve based on the updated counter.

2. The method of claim 1, wherein the plurality of content components include a plurality of video components, a plurality of audio components, or a plurality of subtitle components.

3. The method of claim 1, further comprising comparing values of the updated counters associated with the plurality of content components to a synchronization parameter to determine which of the plurality of content components associated with the additional media content item.

4. The method of claim 3, further comprising removing at least one of the plurality of content components from memory based on the comparison.

5. A system for managing media content items, the system comprising:

a hardware processor that is configured to:

receive media content item as an input signal, wherein the input signal includes a plurality of different content components associated with the media content item;

parse the received media content item into the plurality of content components of the media content item;

associate a counter with each of the plurality of content components, wherein the counter begins at an initial value;

receive a request to playback the media content item, wherein the media content item includes a portion of the plurality of content components;

determine that at least one content component of the plurality of content components is being played back in response to receiving the request to playback the media content item;

update the counter associated with each of the plurality of content components based on the portion of the plurality of content components that are played back by incrementing a value of the counter associated with the at least one content component from the initial value and decrementing values of the counters associated with the plurality of content components that are not being played back from the initial value; and

16

in response to receiving a request to playback an additional media content item, determine which of the plurality of content components associated with the additional media content item to retrieve based on the updated counter.

6. The system of claim 5, wherein the plurality of content components include a plurality of video components, a plurality of audio components, or a plurality of subtitle components.

7. The system of claim 5, wherein the hardware processor is further configured to compare values of the updated counters associated with the plurality of content components to a synchronization parameter to determine which of the plurality of content components associated with the additional media content item.

8. The system of claim 7, wherein the hardware processor is further configured to remove at least one of the plurality of content components from memory based on the comparison.

9. A non-transitory computer-readable medium comprising computer-executable instructions that, when executed on a hardware processor, perform a method for managing media content items, the method comprising:

receiving media content item as an input signal, wherein the input signal includes a plurality of different content components associated with the media content item;

parsing the received media content item into the plurality of content components of the media content item;

associating a counter with each of the plurality of content components;

receiving a request to playback the media content item, wherein the media content item includes a portion of the plurality of content components;

determining that at least one content component of the plurality of content components is being played back in response to receiving the request to playback the media content item;

updating the counter associated with each of the plurality of content components based on the portion of the plurality of content components that are played back by incrementing a value of the counter associated with the at least one content component from the initial value and decrementing values of the counters associated with the plurality of content components that are not being played back from the initial value; and

in response to receiving a request to playback an additional media content item, determining which of the plurality of content components associated with the additional media content item to retrieve based on the updated counter.

10. The non-transitory computer-readable medium of claim 9, wherein the plurality of content components include a plurality of video components, a plurality of audio components, or a plurality of subtitle components.

11. The non-transitory computer-readable medium of claim 9, wherein the method further comprises comparing values of the updated counters associated with the plurality of content components to a synchronization parameter to determine which of the plurality of content components associated with the additional media content item.

12. The non-transitory computer-readable medium of claim 11, wherein the method further comprises removing at least one of the plurality of content components from memory based on the comparison.