



US009523636B2

(12) **United States Patent**
Pelletier et al.

(10) **Patent No.:** **US 9,523,636 B2**
(45) **Date of Patent:** **Dec. 20, 2016**

(54) **PULSE WIDTH MODULATION OF CONTINUUM SOURCES FOR DETERMINATION OF CHEMICAL COMPOSITION**

(58) **Field of Classification Search**
CPC G01J 1/08; G01N 21/59; G01N 2201/022; G01N 2201/061; G01V 8/12; H01J 63/00; H01J 63/02

(Continued)

(71) Applicant: **Halliburton Energy Services, Inc.**,
Houston, TX (US)

(56) **References Cited**

(72) Inventors: **Michael Pelletier**, Houston, TX (US);
William Soltmann, The Woodlands, TX (US);
David L. Perkins, The Woodlands, TX (US);
Christopher M. Jones, Houston, TX (US)

U.S. PATENT DOCUMENTS

3,826,920 A 7/1974 Woodroffe et al.
4,907,895 A 3/1990 Everest

(Continued)

(73) Assignee: **Halliburton Energy Services, Inc.**,
Houston, TX (US)

FOREIGN PATENT DOCUMENTS

(*) Notice: Subject to any disclaimer, the term of this patent is extended or adjusted under 35 U.S.C. 154(b) by 21 days.

EP 2320213 A2 5/2011
JP 2002365217 A 12/2002

(Continued)

OTHER PUBLICATIONS

(21) Appl. No.: **14/441,484**

International Search Report and The Written Opinion of the International Searching Authority, or the Declaration, Sep. 27, 2013, PCT/US2012/072194, 14 pages, ISA/KR.

(22) PCT Filed: **Dec. 28, 2012**

(Continued)

(86) PCT No.: **PCT/US2012/072194**

§ 371 (c)(1),
(2) Date: **May 7, 2015**

Primary Examiner — Sang Nguyen

(74) *Attorney, Agent, or Firm* — Haynes and Boone, LLP

(87) PCT Pub. No.: **WO2014/105071**

PCT Pub. Date: **Jul. 3, 2014**

(57) **ABSTRACT**

(65) **Prior Publication Data**

US 2015/0300944 A1 Oct. 22, 2015

A light source and a method for its use in an optical sensor are provided, the light source including a resistively heated element. The light source includes a power circuit configured to provide a pulse width modulated voltage to the resistively heated element, the pulse width modulated voltage including: a duty cycle with a first voltage; and a pulse period including a period with a second voltage, wherein: the duty cycle, the first voltage, and the pulse period are selected so that the resistively heated element is heated to a first temperature; and the first temperature is selected to emit black body radiation in a continuum spectral range. Also provided is an optical sensor for determining a chemical composition including a light source as above.

(51) **Int. Cl.**
G01N 21/31 (2006.01)
G01V 8/10 (2006.01)

(Continued)

(52) **U.S. Cl.**
CPC **G01N 21/255** (2013.01); **E21B 47/102** (2013.01); **E21B 49/08** (2013.01); **G01J 3/0205** (2013.01);

(Continued)

8 Claims, 8 Drawing Sheets

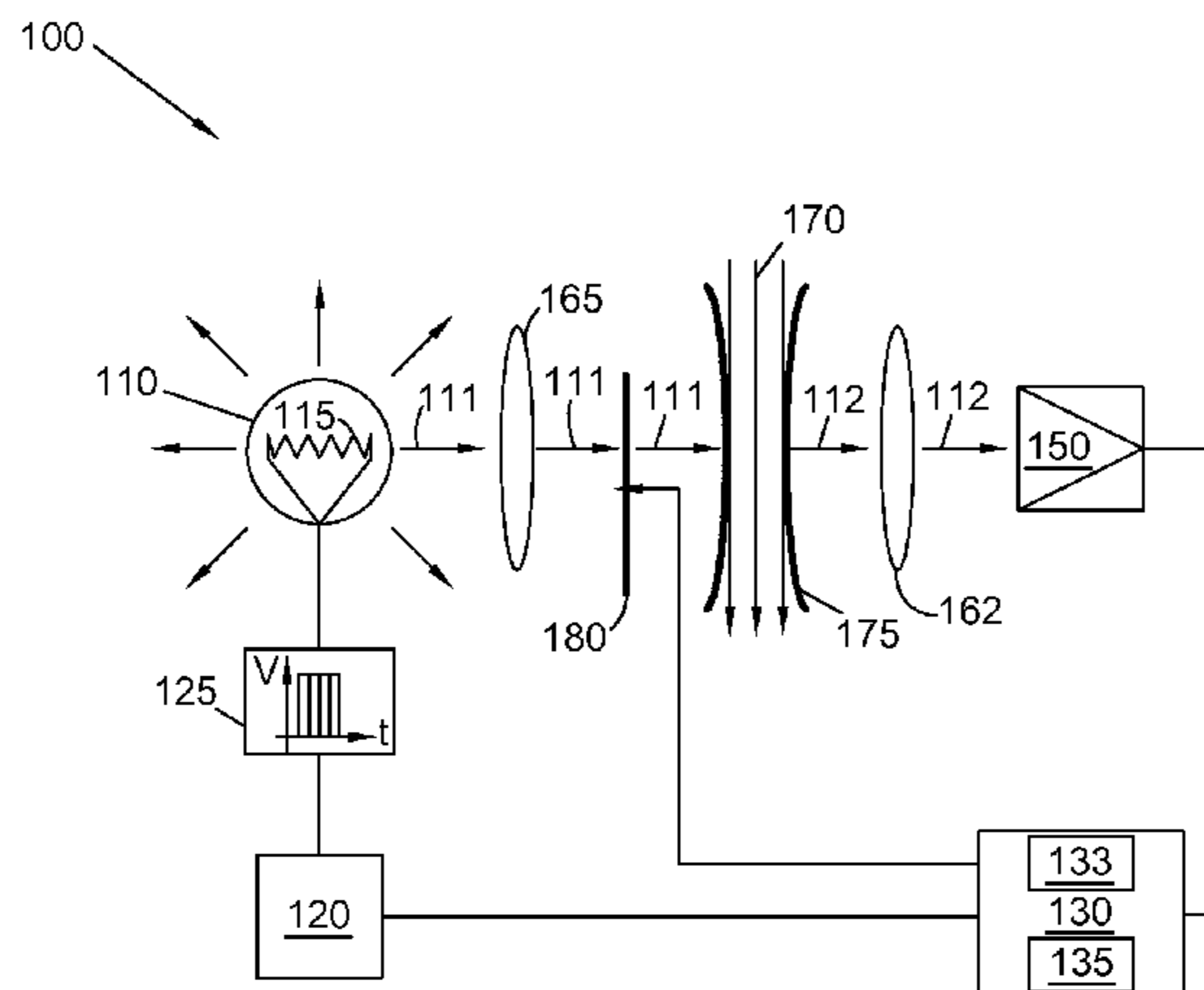

(51)	Int. Cl.		5,388,909 A	2/1995	Johnson et al.	
	<i>H03K 7/08</i>	(2006.01)	5,591,975 A	1/1997	Jack et al.	
	<i>G01N 21/47</i>	(2006.01)	5,621,521 A	4/1997	Takahashi	
	<i>G01N 21/25</i>	(2006.01)	6,400,449 B2	6/2002	Maris et al.	
	<i>G01J 3/433</i>	(2006.01)	6,404,494 B1	6/2002	Masonis et al.	
	<i>G01J 3/10</i>	(2006.01)	7,301,164 B2	11/2007	Daugherty et al.	
	<i>G01J 5/52</i>	(2006.01)	7,372,031 B2	5/2008	Cerwin et al.	
	<i>H05B 37/02</i>	(2006.01)	7,796,263 B2	9/2010	Csutak	
	<i>E21B 49/08</i>	(2006.01)	7,968,848 B2	6/2011	Johnson et al.	
	<i>G01J 3/02</i>	(2006.01)	8,038,947 B2	10/2011	Thompson	
	<i>G01J 3/427</i>	(2006.01)	8,946,660 B2*	2/2015	Pelletier	H01J 63/00 250/504 R
	<i>E21B 47/10</i>	(2012.01)	2003/0178578 A1	9/2003	Rao et al.	

(52)	U.S. Cl.		2007/0049809 A1	3/2007	Bechtel et al.	
	CPC	<i>G01J 3/027</i> (2013.01); <i>G01J 3/10</i>	2007/0279636 A1	12/2007	Li et al.	
		(2013.01); <i>G01J 3/108</i> (2013.01); <i>G01J 3/427</i>	2010/0117667 A1	5/2010	Lo	
		(2013.01); <i>G01J 3/433</i> (2013.01); <i>G01J 5/522</i>	2011/0108720 A1	5/2011	Ford et al.	
		(2013.01); <i>G01N 21/31</i> (2013.01); <i>G01N</i>	2011/0184678 A1	7/2011	Lee et al.	
		<i>21/47</i> (2013.01); <i>G01V 8/10</i> (2013.01); <i>H03K</i>	2011/0216311 A1	9/2011	Kachanov et al.	
		<i>7/08</i> (2013.01); <i>H05B 37/0209</i> (2013.01);	2012/0228502 A1	9/2012	Willis et al.	
		<i>G01N 2201/061</i> (2013.01); <i>G01N 2201/12</i>				
		(2013.01)				

FOREIGN PATENT DOCUMENTS

(58)	Field of Classification Search		WO	WO 2007/064370 A2	6/2007
	USPC	356/432-444; 250/214 DC, 208.2, 504 R	WO	WO 2009/005799 A1	1/2009
		See application file for complete search history.			

OTHER PUBLICATIONS

(56)	References Cited		Partial Search Report issued for European Patent Application No. 12890899, dated Jun. 30, 2016, 8 pages.		
	U.S. PATENT DOCUMENTS		* cited by examiner		
	5,026,992 A	6/1991 Wong			
	5,141,312 A	8/1992 Thompson et al.			

FIG. 1

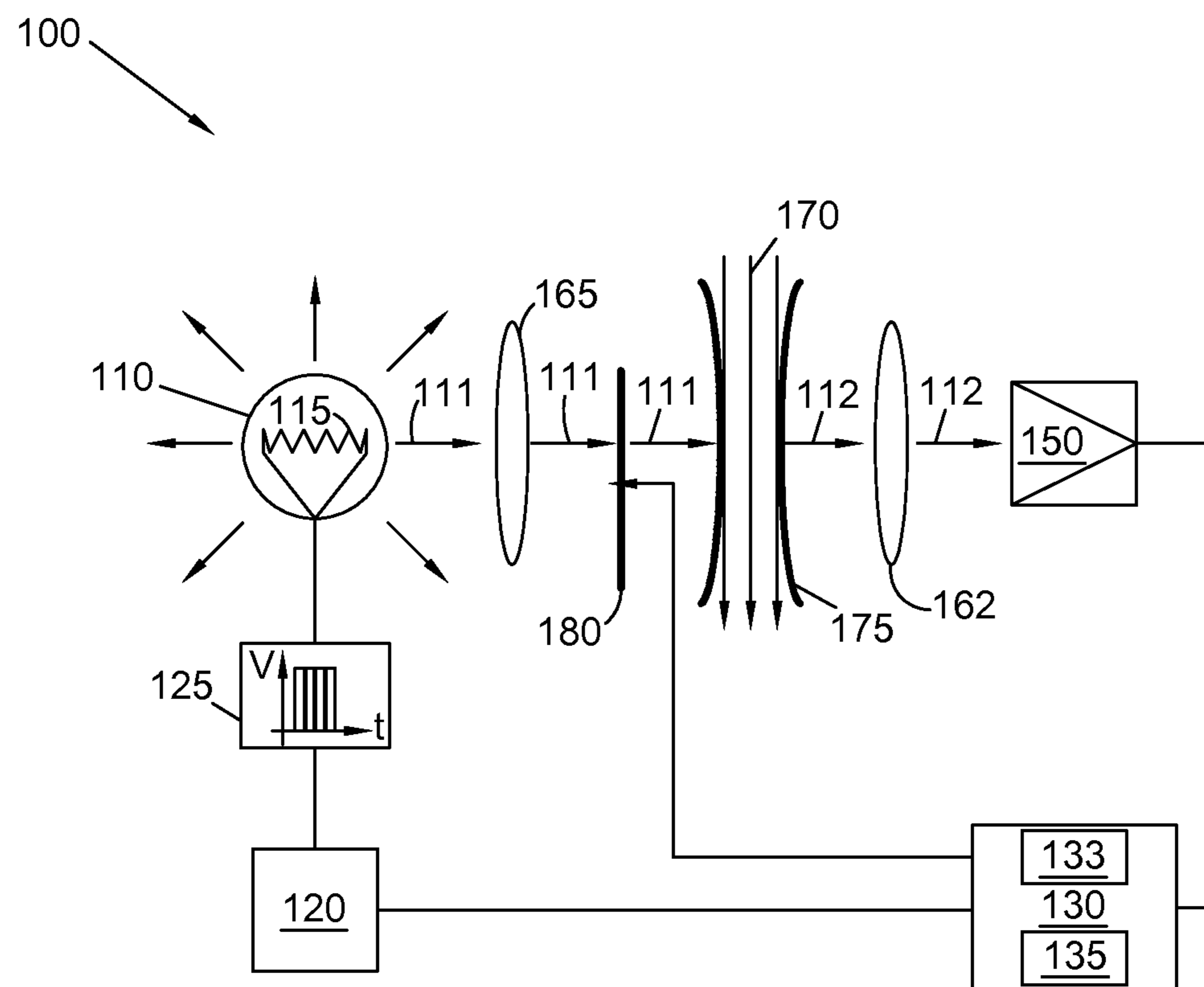

FIG. 2

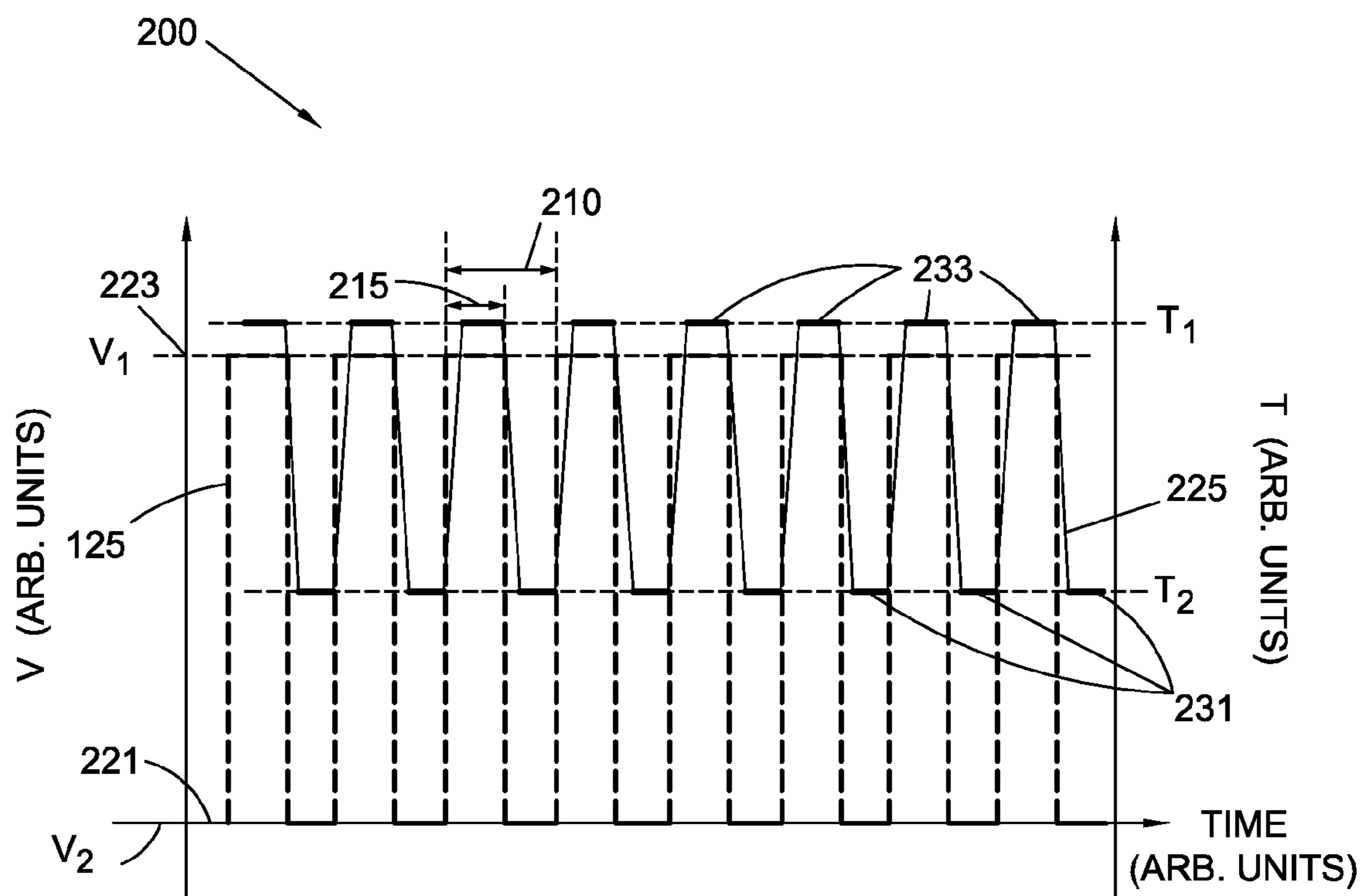

FIG. 3A

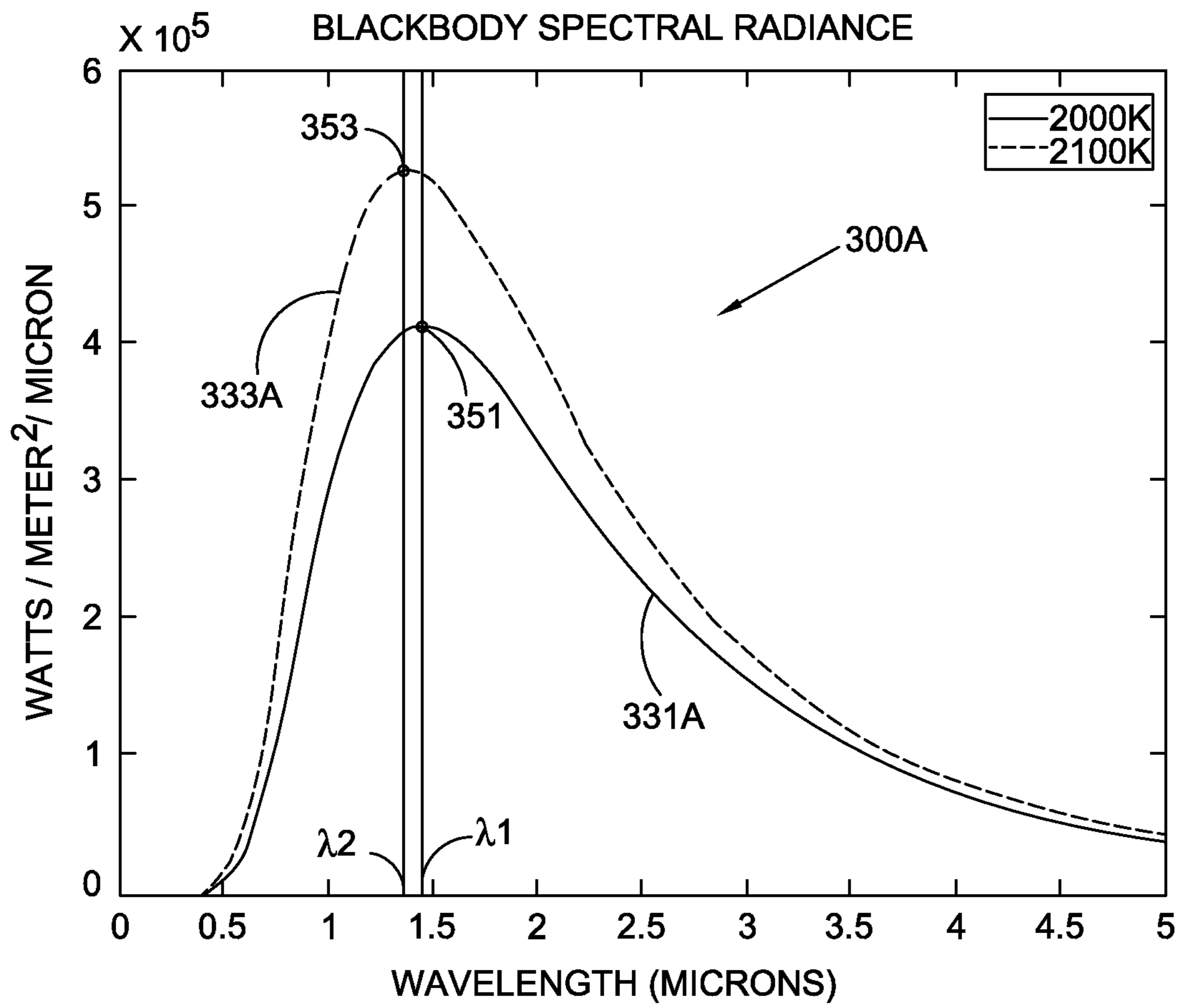

FIG. 3B

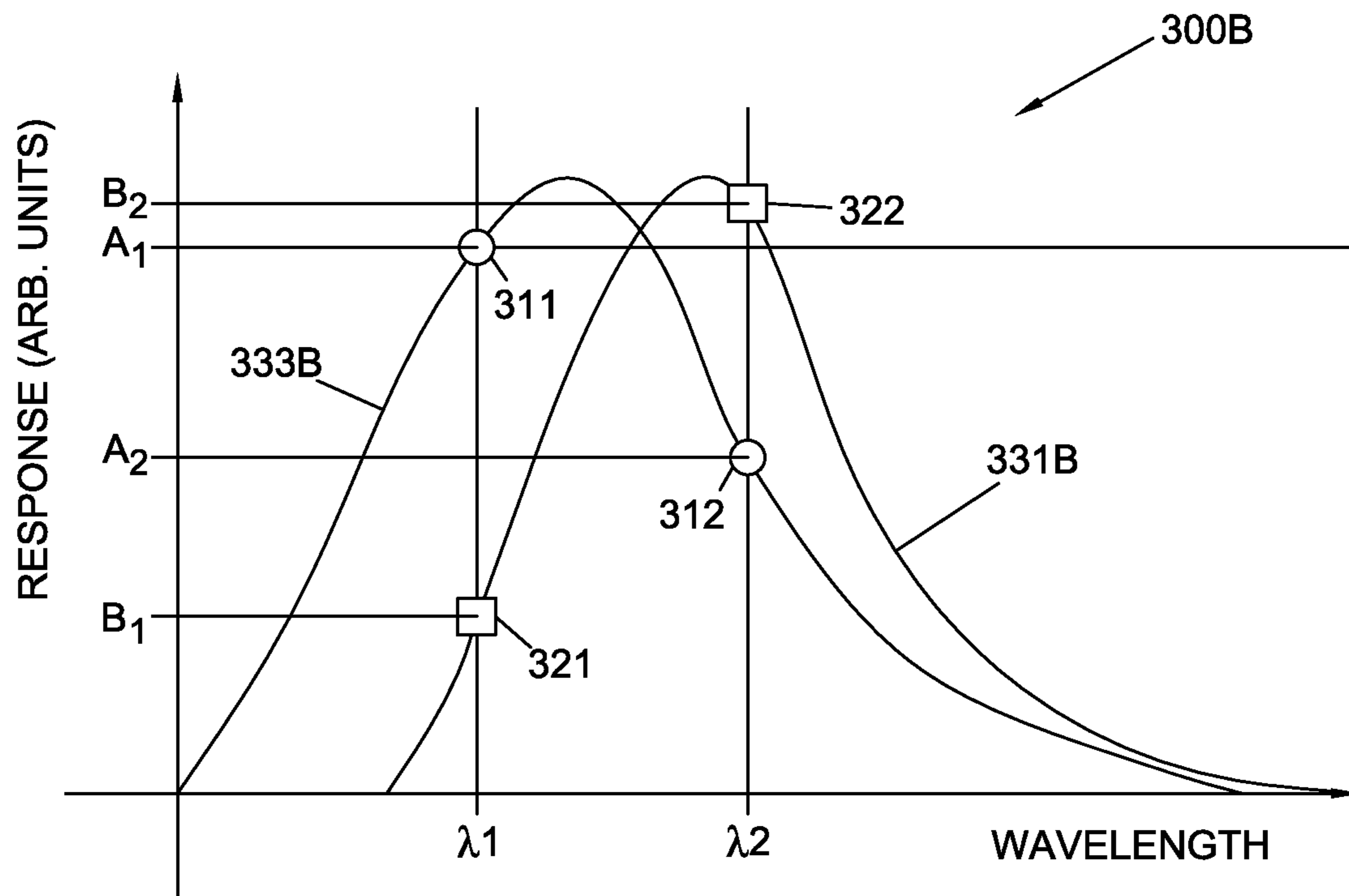

FIG. 4

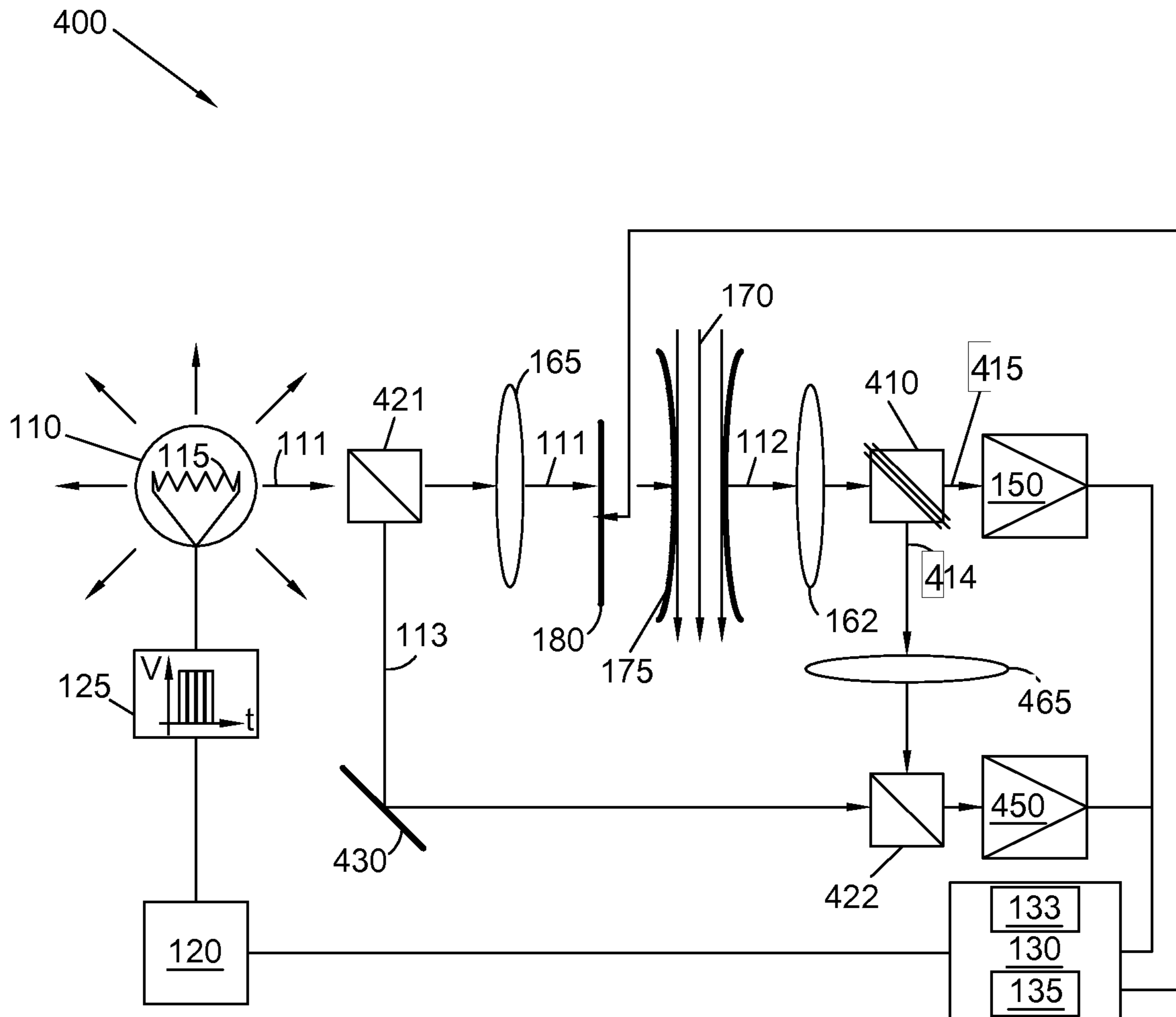

FIG. 5

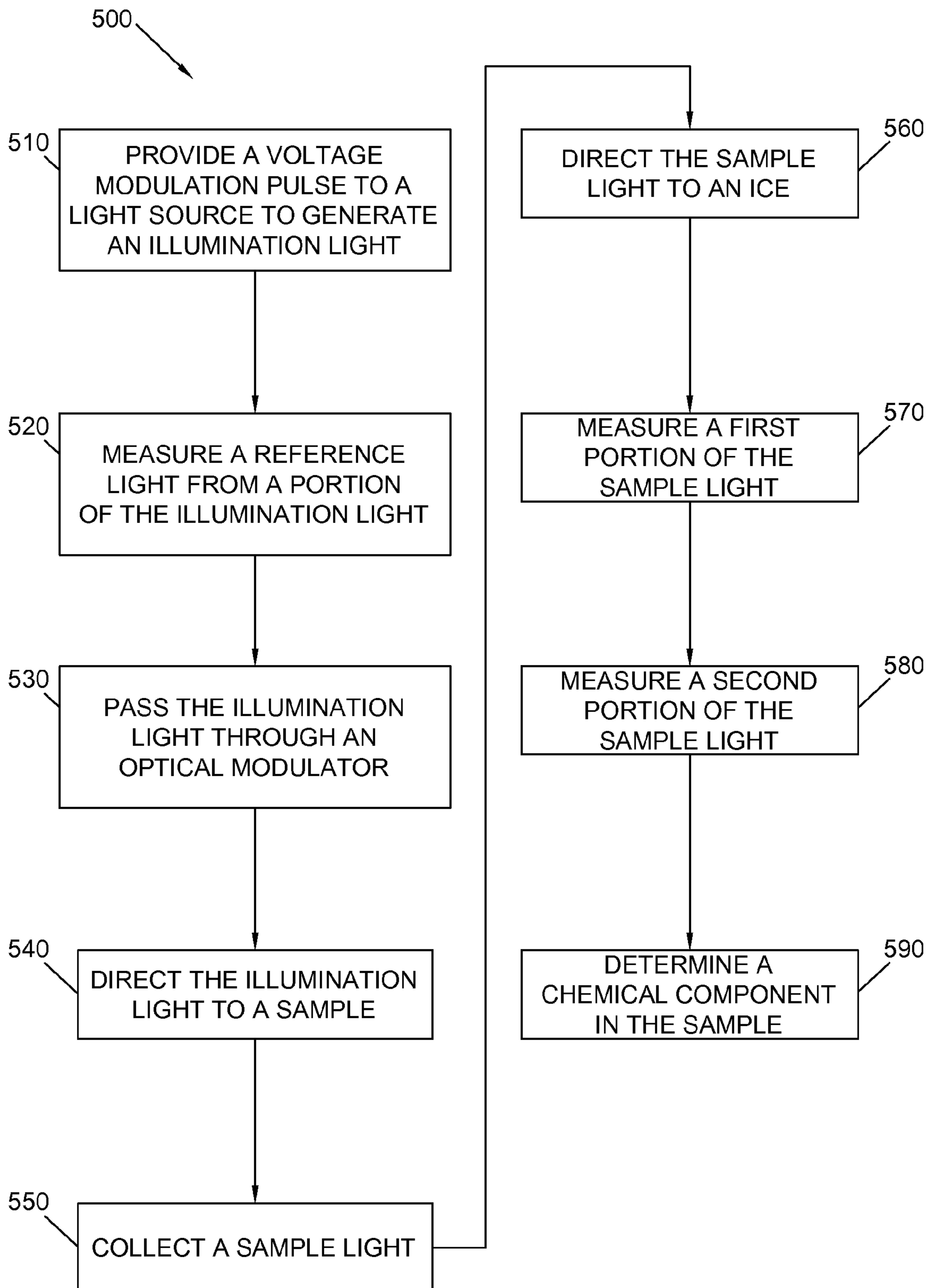

FIG. 6

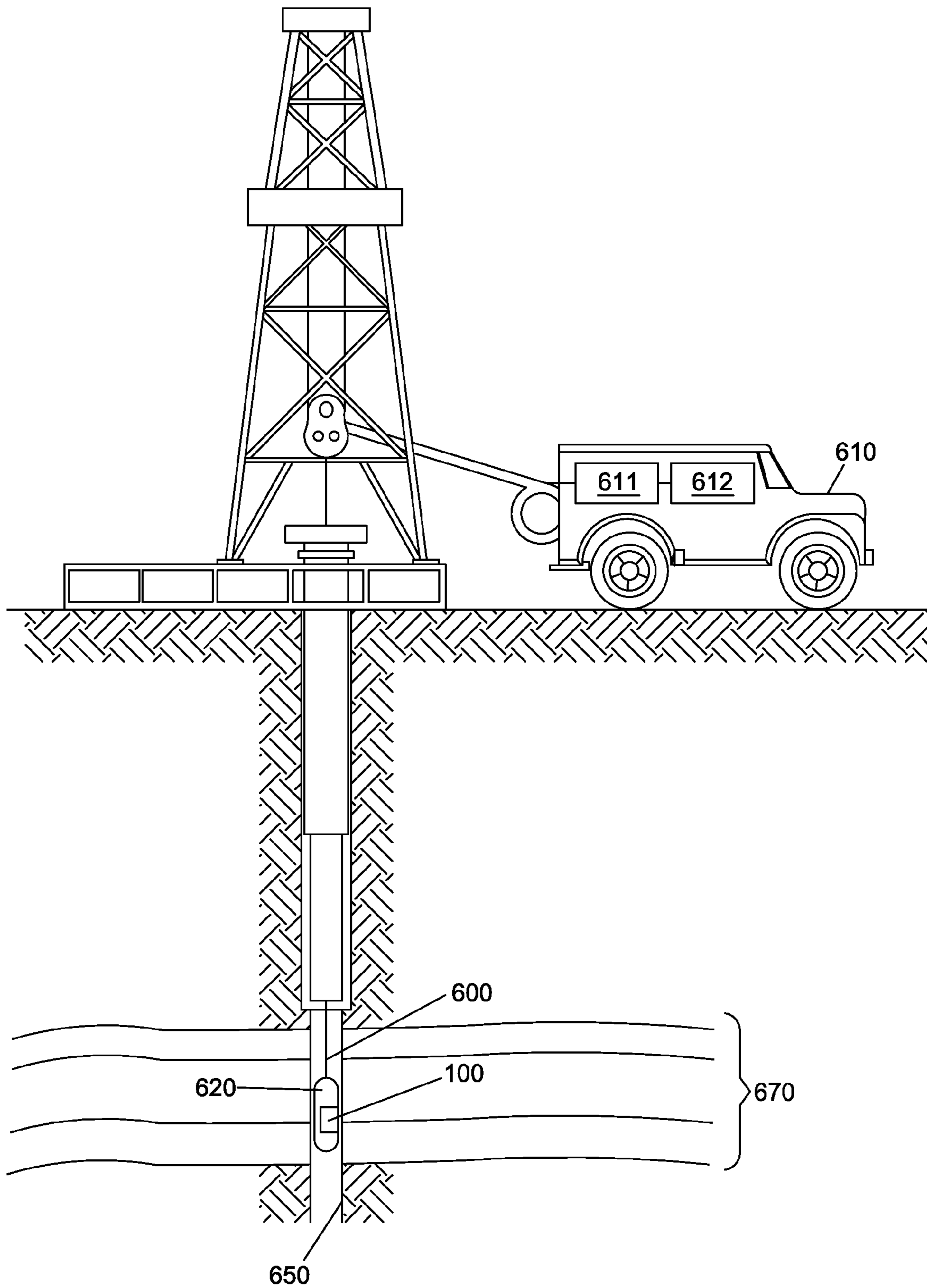
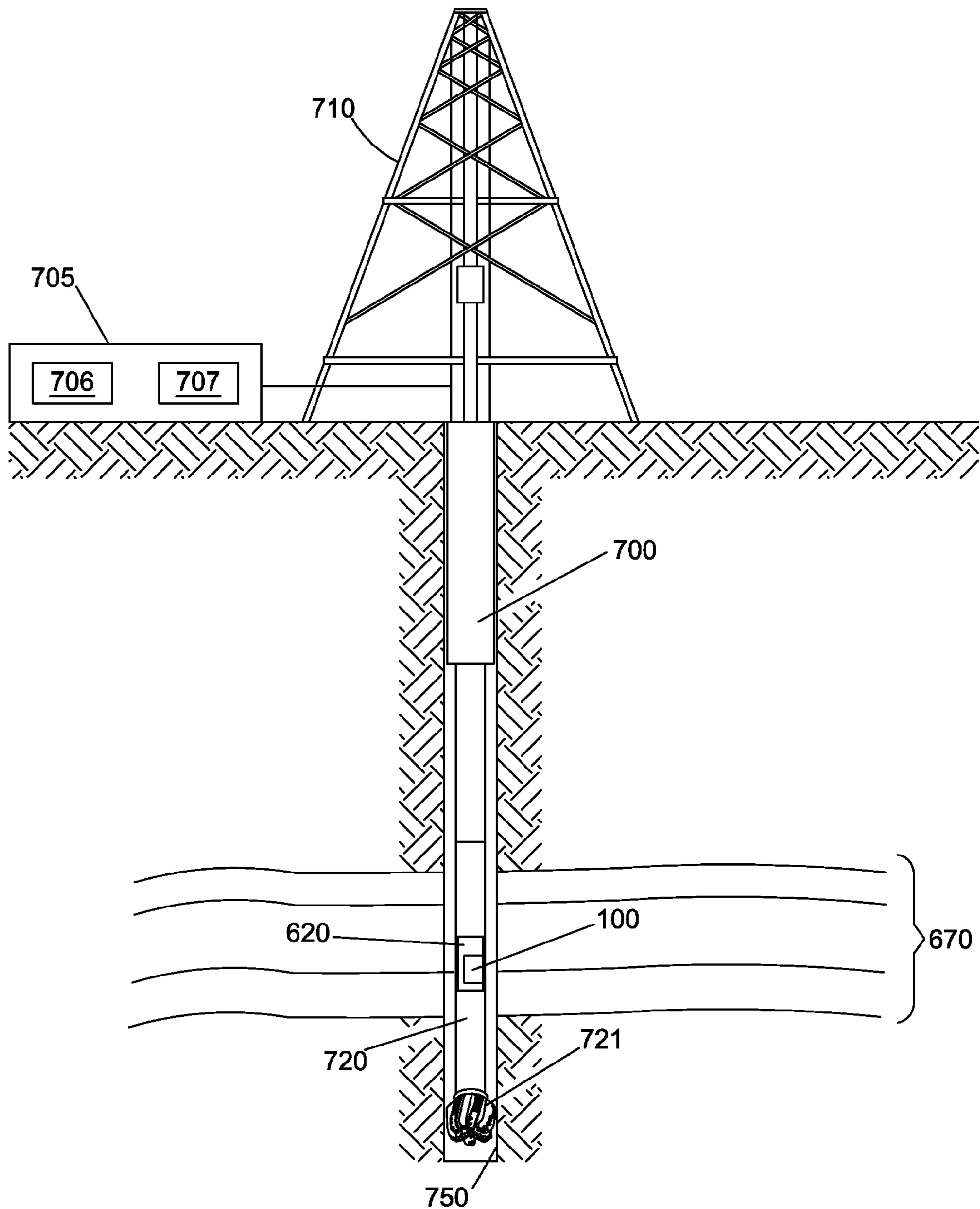

FIG. 7



1

**PULSE WIDTH MODULATION OF
CONTINUUM SOURCES FOR
DETERMINATION OF CHEMICAL
COMPOSITION**

The present application is a U.S. National Stage patent application of International Patent Application No. PCT/US2012/072194, filed on Dec. 28, 2012, the benefit of which is claimed and the disclosure of which is incorporated herein by reference in its entirety.

BACKGROUND

1. Technical Field

Embodiments disclosed herein relate to the field of optical sensors. More particularly, embodiments disclosed herein are related to the field of modulated sources for optical sensors to measure the chemical composition in fluids.

2. Description of Related Art

Optical sensors typically use a light source to provide the excitation of atoms or molecules for prediction or detection of chemical constituents contained in the liquid, solid, or gases under examination. The light source is provided as part of the system or sensor used to study these materials and generally cover a portion, or portions, of the electromagnetic spectral region from the ultraviolet (UV) to the far infrared (FIR). Different types of light sources used may provide a continuum emission, line emission, and continuum plus line and quasi-continuum emission, according to the spectral distribution of the light provided. Examples of these types of sources are incandescent lamps, hollow cathode discharge lamps, xenon-mercury arc lamps, light emitting diodes (LEDs) and lasers, respectively.

Typically, continuum sources like tungsten lamps are operated at a fixed, continuous voltage, or current. In typical systems, the detected signal is derived from modulating the light beam with the use of an optical chopper or similar device. Light beam modulation improves the measurements made with these devices by moving the detected signal from a direct current (DC) domain to the alternating current (AC) domain, improving signal drift over time.

An alternative approach is to utilize modulation of the light source itself, without the use of external elements such as optical choppers or modulators. Current systems that modulate light sources typically include semiconductor light sources. In some applications, a modulated current is applied to a semiconductor light source having an emitter. The current modulation produces a temperature modulation in a gain region of the emitter, thus changing the emitted center wavelength. This method has been used to measure properties of a downhole fluid in oil exploration and extraction applications. However, light source modulation methods such as used in state-of-the-art applications include light sources providing a limited bandwidth such as lasers and semiconductor light sources, typically emitting light within a narrow wavelength band.

What is needed is an optical source and a method for using the optical source providing measurement stability and high signal-to-noise (SNR) ratio in a broad spectral band, to determine the chemical composition of fluids including hydrocarbons (e.g., crude oils, natural gas, or the like) and/or other fluids present in a downhole environment.

BRIEF SUMMARY

A light source for use in an optical sensor according to some embodiments may include a resistively heated ele-

2

ment; and a power circuit configured to provide a pulse width modulated voltage to the resistively heated element, the pulse width modulated voltage including: a duty cycle with a first voltage; and a pulse period including a period with a second voltage, wherein: the duty cycle, the first voltage, and the pulse period are selected so that the resistively heated element is heated to a first temperature; and the first temperature is selected to emit black body radiation in a continuum spectral range.

According to some embodiments an optical sensor for determining a chemical composition of a sample may include: a light source including a resistively heated element; a power circuit configured to provide a pulse width modulated voltage signal to the resistively heated element; an optical delivery system to direct an illumination light to a sample; a sample cavity containing the sample and configured to receive the illumination light; an optical collection system to collect a sample light from the sample; and a detector synchronized to the pulse width modulated voltage signal, the detector configured to measure the sample light from the optical collection system.

According to embodiments disclosed herein a method of determining a chemical composition of a sample using an optical sensor may include: generating an illumination light using a pulse width modulated voltage; collecting a sample light; measuring the sample light with a detector; and determining a chemical component in the sample; wherein the pulse width modulated voltage includes a plurality of pulses having a first frequency, and a duty cycle.

These and other embodiments will be described in further detail below, with reference to the following drawings.

BRIEF DESCRIPTION OF THE DRAWINGS

FIG. 1 shows an optical sensor including a modulated optical source, according to some embodiments.

FIG. 2 shows a chart including a pulse modulated signal provided to an optical source, according to some embodiments.

FIG. 3A shows a chart including non-normalized spectral radiance curves at two different temperatures.

FIG. 3B shows a differential spectrum response from an optical source, according to some embodiments.

FIG. 4 shows an optical sensor including a modulated optical source and an integrated computational element (ICE), according to some embodiments.

FIG. 5 shows a flow chart for a method to determine chemical composition of a sample using an optical sensor, according to some embodiments.

FIG. 6 shows an optical sensor using a modulated optical source in a wireline logging application, according to some embodiments.

FIG. 7 shows a drill bore including a sensor using a modulated optical source in a logging-while-drilling (LWD) application, according to some embodiments.

Wherever possible, the same reference numbers are used throughout the drawings to refer to the same or like elements.

DETAILED DESCRIPTION

Optical sensors consistent with this disclosure are used to determine the chemical composition of a sample of interest. Embodiments of an optical sensor as described herein include a high frequency pulsed-width modulation of a continuum source, to improve sensor performance. For determination of the chemical composition of a sample, use

of a continuum light source having a broad spectral band is desirable. A broad spectral band may include visible (VIS) wavelengths from close to the UV region (380-400 nm to about 750 nm), to the near infrared region (NIR, from 750 nm to about 2500 nm), and the mid-infrared region (MIR, from about 2500 nm up to 10 μ m and beyond).

Many chemical substances have characteristic optical responses across these three spectral regions (UV-VIS, NIR, and MIR). An optical response from a chemical substance may be obtained by scattering phenomena such as Raman, Brillouin, or Rayleigh scattering, absorption phenomena such as VIS or NIR absorption, or an absorption/emission phenomenon such as fluorescence. Using a broad band light source allows the measurement of many different chemical components, even when they are combined in the same sample. Furthermore, use of a broad band light source may enable the combination of a plurality of phenomena for measurements in different spectral regions. For example, fluorescence spectroscopy may be used in the VIS, Raman spectroscopy may be used in the NIR, and absorption spectroscopy may be used in the MIR. Thus, according to some embodiments, all the above measurement techniques may be applied using the same broadband light source.

Some embodiments of optical sensors as disclosed herein provide a pulse width modulation to a voltage signal, i.e. a pulse width modulated voltage, generating a current in an electrically resistive element of a continuum light source. The pulse width modulation may be provided at a relatively high frequency of several kilo-Hertz (kHz), such as 10 kHz, or more. A continuum light source using a resistive element may be a tungsten filament lamp. In addition to a high frequency modulation of the light source, some embodiments include a lower frequency modulation to the optical beam generated by the lamp. For example, a low frequency modulation may be obtained by using an optical chopper placed in the optical path of a light beam from the lamp, producing a beam modulation of a few hundred Hz, or less.

FIG. 1 shows an optical sensor 100 including a modulated light source 110, according to some embodiments. Optical sensor 100 includes a power circuit 120 providing a voltage signal 125 to light source 110. According to some embodiments, voltage signal 125 is a pulse width modulated voltage signal. Light source 110 provides an illumination light 111 upon receiving voltage signal 125. In some embodiments, light source 110 includes a resistively heated element 115. Resistively heated element 115 may be a filament which, upon receiving voltage signal 125, allows a current flow that resistively heats filament 115 up to a temperature T_0 . The heated filament 115 has a black body emissivity, ϵ , desirably close to 1. In some embodiments, filament 115 is made of an electrically conductive material such as tungsten, and has an emissivity between 0.03 and up to 0.35. The spectral band of the electromagnetic radiation emitted by filament 115 may be selected according to the Planck distribution for a black body at temperature T_0 . Thus, by selecting the temperature T_0 , a continuum spectral range including the VIS, NIR, and MIR regions may be obtained at desired emission intensity.

Optical sensor 100 also includes an optical delivery system 165 to collect a portion of the radiation emitted by filament 115 in light source 110 and to form a collimated beam for delivery of illumination light 111 to a sample 170. Sample 170 may be flowing continuously through a sample cavity 175, or may be extracted and stored within sample cavity 175. While the arrows in sample 170 indicate a flow, in some embodiments sample 170 may be stationary within an enclosed cavity 175. In some embodiments, sample cavity 175 may have at least one portion or window trans-

parent to illumination light 111. Thus, sample cavity 175 may include at least one portion or window transparent to wavelengths of interest for the measurement. An optical modulator 180 may be placed in the path of the collimated beam, before illumination light 111 interacts with sample 170. After illumination light 111 interacts with sample 170, optical collection system 162 collects a sample light 112. Optical collection system 162 provides sample light 112 to detector 150 which produces a signal. Optical sensor 100 may also include controller 130 having a processor circuit 133 and a memory circuit 135. Controller 130 performs signal processing, data analysis and data storage using the signal provided by detector 150, processing circuit 133, and memory circuit 135.

In some embodiments, light source 110 in optical sensor 100 may be a tungsten light source. More generally, light source 110 may be a blackbody continuum source using an electrically resistive element emitting light in a broad spectral band. Light source 110 in optical sensor 100 using pulse width modulated signal 125 may operate at an increased temperature relative to a light source operating at a constant voltage, since the stress induced by a high current in filament 115 is reduced by pulsed width modulated signal 125. An increased operation temperature is desirable to increase output intensity of an optical source, according to Planck's law. Intensity increase at longer wavelengths is particularly desirable, since traditional sources have low intensity in the spectral region beyond 2000 nm. Because of the lower stress to filament 115 under pulse width modulated signal 125, light source 110 has an improved performance in terms of stability. Due to the increased optical intensity at any given wavelength, light source 110 improves SNR in detector 150. Improved stability of light source 110 and higher SNR at detector 150 enhance accuracy and precision of a sample chemical composition determined by optical sensor 100.

In some embodiments the signal from detector 150 is demodulated in controller 130 at a frequency approximately equal to a sum or a difference frequency of the voltage modulation frequency provided to filament 115 (f_1) and the modulation frequency of the optical modulator, or second frequency f_2 . In cases where detector 150 is a cascaded voltage detector, the detector may be synchronized to a combination frequency including a sum or a difference of the first frequency (f_1) and the second frequency (f_2).

In addition, embodiments of optical sensor 100 powered with a battery provide a longer battery lifetime, due to low current usage by pulse width modulated signal 125. For measurement stations using optical sensor 100 in field applications, low current usage results in longer time on station and more measurements between battery charging and/or replacement.

FIG. 2 shows a chart 200 including pulse width modulated signal 125 provided to an optical source, according to some embodiments. The abscissa in chart 200 corresponds to time, the ordinate in the left hand axis is voltage, and the ordinate in the right hand axis is temperature. Chart 200 includes pulse width modulated signal 125, plotted in relation to the voltage axis (ordinate to the left), and a filament temperature curve 225 (ordinate to the right). According to some embodiments, pulse width modulated signal 125 has a period 210 and a duty cycle 215. Duty cycle 215 includes the time during which lamp filament 115 is turned 'on' at a voltage $223 V_1$. Outside of duty cycle 215, filament 115 may be turned 'off' completely (0 voltage), or may be turned 'on' at a low voltage 221 (V_2).

Filament temperature curve 225 includes time segments 233 at a high temperature T_1 , and time segments 231 at a low

temperature T_2 . Time segments **233** may overlap at least in part with duty cycle **215** of filament **115**. Indeed, when filament **115** is operated at voltage **223** (V_1), a current resistively heats filament **115** to temperature T_1 . The heating process may include a small time delay, as thermal equilibrium is reached in filament **115**. This time delay is shown in FIG. **2** as a small displacement of time segments **233** to the right relative to voltage pulses, along the abscissa. Likewise, time segments **231** approximately overlap with portions of signal **125** where voltage **221** applied to filament **115** is zero, or low. When the voltage applied to filament **115** is zero or low, no current or a very limited amount of current flows through filament **115**. The result is a cooling of the filament down to temperature T_2 , as the resistive heating stops.

In some embodiments, voltage **223** (V_1) may be approximately 20 V, with a duty cycle **215** of approximately 1.5 μs and a period **210** of approximately 100 μs (switching frequency of 10 kHz). In such embodiments, time segments **233** (approximately 1.5 μs or less) may be much shorter than time segments **231** (approximately 98.5 μs). Thus, light source **110** may have enhanced lifetime and operational stability, since the maximum stress for filament **115** at time segments **233** is reduced and interleaved with limited or no stress at time segments **231**.

Duty cycle **215**, voltage **221**, and pulse period **210** are selected so that filament **115** is heated to high temperature T_1 . Temperature T_1 is selected to emit black body radiation in a continuum spectral range. In some embodiments, it is desirable to obtain a broad continuum spectral band, including the VIS, NIR, and MIR regions up to about 5 μm or more, with high enough emission intensity. In such configurations, it is desirable that temperature T_1 be as high as several thousand degrees Kelvin (K). For example, in some embodiments T_1 may reach about 2000 K, 3000 K, or up to about 5000 K. Further according to some embodiments, duty cycle **215**, voltage **221**, and pulse period **210** may be selected so that filament **115** reaches temperature T_2 . Temperature T_2 may be selected to emit blackbody radiation in a second continuum spectral range different from the continuum spectral range emitted by filament **115**, at temperature T_1 . In some embodiments, the continuum spectral range emitted at temperature T_1 and the second continuum spectral range emitted at temperature T_2 may be used in a differential spectrum configuration to enhance the SNR of the measurement.

In some embodiments, the signal from detector **150** is demodulated in controller **130** at a first frequency (f_1) approximately equal to the frequency of pulse width modulated signal **125**. In some embodiments, the signal from detector **150** is synchronized in controller **130** with duty cycle **215** in pulse width modulated signal **125**. Further according to some embodiments, detector **150** may be a cascaded voltage detector that is turned 'on' synchronously with pulse width modulated signal **125** provided to filament **115**. In such embodiments, the SNR of the measurement is increased due to the filtering of low frequency and $1/f_1$ flicker noise, where f_1 is the modulation frequency (i.e., the frequency of the voltage pulses in pulse width modulated signal **125**).

FIG. **3A** shows a chart **300A** including non-normalized spectral radiance curves **331A** and **333A**. The abscissa axis (X-axis) in FIG. **3A** corresponds to wavelength in microns (1 micron = 1 μm = 10^{-6} m). The ordinate axis (Y-axis) in FIG. **3A** is the spectral radiance in Watts per meter squared, per micron. Curve **331A** is obtained at a low temperature $T_2=2000\text{K}$, and curve **333A** is obtained at a high temperature $T_1=2100\text{K}$. The wavelength ranges for curves **331A** and

333A are similar, but the overall radiance intensity (ordinate axis, or Y-axis) increases due to the temperature increase. Temperatures T_1 and T_2 in chart **300A** are exemplary only and are not limiting of embodiments consistent with the present disclosure. Accordingly, low temperature T_2 may be the filament temperature during a time segment **231**, and high temperature T_1 may be the filament temperature during a time segment **233**, as described in detail above (cf. FIG. **2**). FIG. **3A** illustrates data point **351** corresponding to a maximal spectral radiance for curve **331A** at a wavelength λ_1 . Likewise, data point **353** in curve **333A** corresponds to a maximal spectral radiance for curve **333A**, at a wavelength λ_2 .

FIG. **3B** shows a differential spectrum response **300B**, according to some embodiments. Differential spectrum response **300B** includes a first normalized response curve **331B** at a low temperature T_2 , and a second normalized response curve **333B** at a high temperature T_1 . Low temperature T_2 may be the filament temperature during one of the time segments **231**, and high temperature T_1 may be the filament temperature during one of the time segments **233**, as described in detail above (cf. FIG. **2**). The first normalized response curve **331B** and the second normalized response curve **333B** may reflect a spectral distribution of sample light **112** resulting from the interaction of illumination light **111** with sample **170**. Response curves **331B** and **333B** may be normalized to the maximum value of a detector response to sample light **112** across the bandwidth of light source **110**. The second response curve **333B** at temperature T_1 has a signal **311** at wavelength λ_1 and signal **312** at wavelength λ_2 . The first response curve **331B** at temperature T_2 has a signal **321** at wavelength λ_1 and signal **322** at wavelength λ_2 . Signal **311** has a response level A_1 and signal **312** has a response level A_2 . Signal **321** has a response level B_1 and signal **322** has a response level B_2 . Response levels A_1 , A_2 , B_1 , and B_2 , may be related to signals obtained using a photodetector such as photodetector **150** (cf. FIG. **1**).

Response curves **331B** and **333B** may represent detector signal levels for a plurality of wavelengths within the bandwidth of light source **110**. In some embodiments, response curves **331B** and **333B** may include Raman, Brillouin, Rayleigh, fluorescence, or absorption spectra from the sample. According to some embodiments, a plurality of response curves such as normalized curves **331** and **333** may be stored in memory circuit **135**. For example, a normalized response curve may be stored in memory circuit **135** for each of a chemical component that may be found in a sample. Furthermore, for each of the chemical components that may be found in a sample, a plurality of normalized response curves may be stored in memory circuit **135**, each corresponding to a different temperature of filament **115** in light source **110**.

In a differential spectrum measurement as shown in FIG. **3B**, a contrast value is obtained from response signals at two different wavelengths λ_1 and λ_2 , for a given normalized spectral response curve. In some embodiments, a contrast value may be obtained by subtracting a response value from the spectral response curve at wavelength λ_2 from a response value from the spectral response curve at wavelength λ_1 . Further, a differential spectrum measurement may use the contrast values from two different spectral response curves to enhance the SNR of a detected signal. For example, a differential spectrum measurement may subtract a contrast value from a first spectral response curve from the contrast value of a second spectral response curve.

As described in FIG. **3B** a first spectral response curve may be normalized curve **333B** and a first difference contrast

value from the response at wavelength λ_2 and wavelength λ_1 may be $\Delta A = A_2 - A_1$. A second spectral response curve may be normalized curve **331B**, and a second difference contrast value may be $\Delta B = B_2 - B_1$. In such case, a differential spectrum measurement may be

$$\delta\Delta = \Delta B - \Delta A \quad (1)$$

If the difference contrast value ΔA or ΔB indicates a signal of interest in the sample, then difference $\delta\Delta$ in Eq. (1) results in a greater signal than would be obtained by using the difference contrast value of a single spectral response curve. For example, in FIG. **3B** the sign of difference contrast value ΔA is opposite to the sign of difference contrast value ΔB . Thus, the subtraction in Eq. (1) increases the value of $\delta\Delta$ over the value of both ΔA and ΔB , increasing the SNR of the measurement. The signal of interest in the sample may be the fractional concentration of a specific chemical component in a fluid. In some embodiments, the signal of interest may be the octane value of a gasoline in a fluid coming from an oil refining process. In some embodiments, the signal of interest may be the fractional water content in a crude oil sample extracted from a downhole drilling tool. Further according to some embodiments, the signal of interest may be the gas-oil-ratio (GOR) in a crude oil sample extracted from a downhole drilling tool.

In some embodiments, a contrast value may be obtained from a ratio of the value of the response curve at wavelength λ_1 to the value of the response curve at wavelength λ_2 . In such embodiments, a similar analysis leading to an enhanced differential signal δR according to Eq. (1) follows from the logarithmic values of a first spectral response curve such as curve **333B** and the logarithmic values of a second spectral response curve such as curve **331B**. Thus, a ratio $rA = A_2/A_1$ and a ratio $rB = B_2/B_1$ may be enhanced in a differential configuration, by finding

$$\delta R = \frac{rB}{rA} = \frac{B_2}{B_1} \cdot \frac{A_1}{A_2} \quad (2)$$

Referring to FIG. **3B**, it is seen that $B_2 > B_1$ and $A_1 > A_2$, thus the value of δR is greater than B_2/B_1 , because $A_1 > A_2$. Also, the value of δR is greater than A_2/A_1 because $\delta R > 1$. Thus, the value of δR is greater than both of the ratio contrast values rB and rA . When the ratio contrast value rB or rA is related to a signal of interest for a sample, then a differential spectrum configuration as shown above enhances the SNR of the measurement.

FIG. **4** shows an optical sensor **400** including a modulated light source **110** and an Integrated Computational Element (ICE) **410**, according to some embodiments. Optical sensor **400** is similar to optical sensor **100** described in detail above (cf. FIG. **1**). Optical sensor **400** includes a reference light detector **450**, and an ICE **410** interacting with sample light **112**. Reference light detector **450** measures a reference light **113** separated from illumination light **111** by a first beam splitter **421**, before illumination light **111** interacts with the sample **170**. In some embodiments, reference light **113** is separated from the illumination light **111** before passing through optical modulator **180**. Reference light **113** is sent through a second beam splitter **422** towards detector **450** by mirror **430**.

One of ordinary skill will recognize that the specific combination of mirror, lenses, and beam splitters in optical sensor **100** (cf. FIG. **1**), and in optical sensor **400** is not limiting. Different optical elements well known in the art

may be used in a variety of configurations to produce the same effects for collection, collimation, and delivery of light from light source **110**, through sample **170**, and to detectors **150** and **450**. In some embodiments, beam splitters, mirrors, and lenses may be replaced entirely or partially by optical fiber components such as splitters, circulators, and collimators.

ICE **410** modifies and separates sample light **112** into a modified transmitted light **415** and a modified reflected light **414**. Modified transmitted light **415** is sent to detector **150**. Modified reflected light **414** is collected by optical collection system **465** and sent to detector **450**, by second beam splitter **422**. In some embodiments, ICE **410** may include a multi-layered dielectric filter that separates sample light **112** into modified reflected portion **415** and modified transmitted portion **415** according to wavelength. Thus, the sum of the intensity of modified reflected portion **414** and the intensity of modified transmitted portion **415** of sample light **112** may be equal to or approximately equal to the intensity of sample light **112**. Furthermore, the relative intensity of modified transmitted portion **415** to modified reflected portion **414** of sample light **112** may depend on the chemical composition of sample **170**.

In some embodiments, ICE **410** may be selected so that the relative difference between modified reflected portion **414** of the sample light and modified transmitted portion **415** of the sample light is maximized when a certain chemical of interest is present in the sample. In some embodiments, ICE **410** may be designed such that a contrast value is obtained from measuring modified reflected portion **414** and transmitted portion **415** of sample light **112**, separately. For example, for a contrast value such as difference contrast values ΔA and ΔB (cf. Eq. (1) and FIG. **3**), ICE **410** may be selected such that modified transmitted portion **415** includes value A_1 , and B_1 , and modified reflected portion **414** includes values A_2 and B_2 . Accordingly, the opposite choice may be selected, e.g., ICE **410** may be selected such that modified transmitted portion **415** includes values A_2 and B_2 , and modified reflected portion **414** includes values A_1 and B_1 . In such embodiments, the difference contrast values ΔA and ΔB may be obtained simply by subtracting the signals measured in detectors **150** and **450**. In embodiments using a ratio as a contrast value, such as ratio contrast values rA and rB (cf. Eq. (2) and FIG. **3**), the contrast value may be obtained by dividing the signals measured in detectors **150** and **450**. Signal processing such as subtraction and division of the signals from detectors **150** and **450** is performed in controller **130** by processing circuit **133**. Further data processing may include use of lookup tables and reference spectra stored in memory circuit **135**.

FIG. **5** shows a flow chart for a method **500** to determine chemical composition of a sample using an optical sensor, according to some embodiments. The optical sensor used in method **500** may be optical sensor **100** or optical sensor **400**, described in detail above (cf. FIGS. **1** and **4**). Method **500** may be performed by the controller circuit in an optical sensor, such as controller **130** in optical sensor **100** (cf. FIG. **1**). The controller circuit may include a processor circuit such as processor circuit **133**, to perform operations using commands and data, the commands and data stored in a memory circuit such as memory circuit **135** (cf. FIG. **1**). Furthermore, some steps in method **500** may be performed by a power circuit in the optical sensor, such as power circuit **120** in optical sensor **100** (cf. FIG. **1**). In some embodiments some steps in method **500** may be performed by power circuit **120** upon receiving commands and signals from the controller circuit.

Step **510** includes providing a voltage modulation pulse to a light source, to generate an illumination light (e.g. illumination light **111**, cf. FIG. **1**). According to some embodiments, the voltage modulation pulse may be included in a pulse width modulated signal such as pulse width modulated signal **125**, provided to filament **115** in light source **110** by power circuit **120**. The voltage pulse has a duty cycle such as duty cycle **215** within a period of time such as period **210** (cf. FIG. **2**). Thus, in embodiments where a modulation signal such as pulse width modulated signal **125** is provided to light source **110**, step **510** may be repeated for a plurality of times while a signal is collected. In some embodiments, the frequency of the pulses provided in step **510** may be approximately 10 kHz, or higher.

Step **520** includes measuring a reference light from a portion of the illumination light. Step **520** may include forming a reference light by splitting a portion of the light emitted by the light source in step **510** with a beam splitter such as beam splitter **421** (cf. FIG. **4**). Step **520** may further include reflecting the reference light with a mirror such as mirror **430**, and passing the reference light through a beam splitter such as beam splitter **422**. Step **520** may also include measuring the reference light with a detector such as detector **450**.

Step **530** includes passing the illumination light provided in step **510** through an optical modulator. In some embodiments, step **530** may include collimating the illumination light into a beam using an optical delivery system such as system **165** (cf. FIG. **1**). The optical modulator may be optical modulator **180**. In some embodiments, the optical modulator may be an optical chopper, operating at a low modulation frequency, compared to the frequency of the pulses provided in step **510**. For example, in embodiments where the frequency of the pulses provided in step **510** is about 10 kHz, an optical modulator in step **530** may operate at a frequency of a few hundred Hz, 100 Hz, or even lower.

Step **540** includes directing the illumination light to a sample. The sample in step **540** may be as sample **170** (cf. FIG. **1**). The illumination light in step **540** may interact with the sample through scattering phenomena such as Raman, Brillouin or Rayleigh scattering, or an absorption phenomenon such as VIS or NIR absorption. Interaction of the illumination light with the sample in step **540** may also include an absorption and emission phenomenon such as fluorescence emission. Further according to some embodiments, and depending on the chemical composition of the sample, step **540** may include a combination of scattering, absorption, and emission phenomena as described above.

Step **550** includes collecting a sample light. In some embodiments, step **550** may include using an optical collection system such as optical collection system **162** (cf. FIG. **1**). Step **560** includes directing the sample light to an ICE, such as ICE **410** described in detail above (cf. FIG. **4**). Step **570** includes measuring a first portion of the sample light (e.g., modified transmitted light **415** in FIG. **4**). In some embodiments, step **570** includes using a first detector such as detector **150** to measure a first portion of the sample light transmitted through the ICE in step **560**. Step **580** includes measuring a second portion of the sample light (e.g., the modified reflected light **414** in FIG. **4**) using a second detector, such as detector **450**. In some embodiments the second portion of the sample light may be a light reflected from the ICE in step **560**. In some embodiments, measuring a first portion and a second portion of the sample light includes synchronizing the two detectors with a duty cycle of the voltage modulation pulse. In some embodiments, measuring a first portion and a second portion of the sample

light includes synchronizing the two detectors with a combination frequency including a sum or a difference of the optical modulator frequency and the frequency of the voltage modulation signal.

Step **590** includes determining a chemical component in the sample. According to some embodiments, step **590** may be performed by the controller circuit using a processor circuit and a memory circuit. For example, a controller circuit may use the signals measured in steps **520**, **570**, and **580** to determine a chemical component in the sample. Furthermore, in step **590** the controller circuit may also use a lookup table or a reference spectrum stored in the memory circuit. Thus, step **590** may include comparing a value obtained from the measured signal to a value stored in a lookup table or in a reference spectrum. Moreover, the memory circuit may store a calibration table, such that a difference between the value obtained from the measured signal and the value stored in the lookup table or the reference spectrum may be converted by the processor circuit into a concentration value for the chemical component in step **590**. In some embodiments, step **590** may include use of a multivariate analysis to determine multiple component concentrations in the sample.

In some embodiments, step **590** may include determining whether a certain chemical component is present in the sample or not. In some embodiments, step **590** may further determine the fractional concentration of a chemical component in the sample. The fractional concentration may be a value provided by mass of the sample (e.g., weight percent, % Wt), by volume of the sample (e.g., volume percent, % vol), by molecular counts of the sample (e.g. parts per thousand, million, billion, trillion). In some embodiments, an absolute count of a chemical component may be provided in step **590**.

FIG. **6** shows an optical sensor **100** using a modulated optical source in a sensor **620** for a wireline logging application, according to some embodiments. Wireline logging performs measurements of fluids and substrates in wellbores drilled for oil and hydrocarbon exploration. In some embodiments, a movable unit **610** includes a processor circuit **611** and a memory circuit **612** to provide commands for sensor **620** to perform measurements and store data obtained from the measurements. Accordingly, once a wellbore **650** has been drilled, a wireline logging measurement may be performed by introducing sensor **620** into wellbore **650**, using a wireline **600**. Wellbore **650** may traverse through a layered ground formation **670**. Sensor **620** may have an optical sensor system **100** including a modulated optical source, as disclosed herein. Furthermore, sensor **620** may include a portion of an optical delivery system such as light delivery system **165** and a portion of an optical collection system such as collection system **162** (cf. FIG. **3**). In some embodiments, a portion of light delivery system **165** and an illumination lamp **110** using a modulated optical source, and power circuit **120** may be included in movable unit **610**. Likewise, a portion of optical collection system **162** may be included in movable unit **610**, such as a detector, an amplifier, and an analog-to-digital converter circuit. In some embodiments, optical delivery system **165** and optical collection system **162** may include an optical fiber, or fiber bundle. The optical fiber or fiber bundle carries light signals along wireline **600**.

FIG. **7** shows a drill bore including an optical sensor **100** using a modulated optical source in a logging-while-drilling (LWD) application, according to some embodiments. An LWD configuration logs acoustic and optical data while a wellbore is being drilled. According to FIG. **7**, a bottom hole

11

assembly 720 includes a drill 721 to form a wellbore 750, traversing through layered ground formation 670. Drill 721 may be operated by a controller 705 through drill string 700. A drilling rig 710 provides structural support to drill string 700. Controller 705 may include a processor circuit 706 and a memory circuit 707. Memory circuit 707 stores commands and data used by processor circuit 706 to control bottom hole assembly 720. Controller 705 may also include sensor 620 proximate to drill 721. Sensor 620 may include an optical sensor 100. Sensor 620 may also include a portion of a light illumination system and a portion of a light detection system, as described in detail above (cf. FIG. 6).

In some embodiments, a sensor as disclosed herein may be implemented in permanent monitoring applications. For example, in an oil extraction rig similar to drilling rig 710, optical sensor 100 may determine the chemical composition of the extracted hydrocarbons during regular operations. Further according to some embodiments, an optical sensor such as sensor 100 may be used in a subsea environment of a wireline operation (cf. FIG. 6), an LWD operation (cf. FIG. 7), or a permanent monitoring operation.

Embodiments described herein may provide measurement stability and high SNR ratio in a broad spectral band to more accurately determine the chemical composition of fluids including hydrocarbons such as crude oils, natural gas, and other downhole fluids. Embodiments described herein are exemplary only. One skilled in the art may recognize various alternative embodiments from those specifically disclosed. Those alternative embodiments are also intended to be within the scope of this disclosure. As such, embodiments disclosed herein are limited only by the following claims.

What is claimed is:

1. An optical sensor for determining a chemical composition of a sample, the optical sensor comprising:
 - a light source comprising a resistively heated element;
 - a power circuit configured to provide a pulse width modulated voltage signal to the resistively heated element to heat the resistively heated element to a temperature selected to emit black body radiation in a continuum spectral range;
 - an optical delivery system to direct an illumination light to a sample;
 - a sample cavity containing the sample and configured to receive the illumination light;
 - an optical collection system to collect a sample light;
 - a detector synchronized to the pulse width modulated voltage signal, the detector configured to measure the sample light from the optical collection system; and
 - an optical modulator configured to modulate the illumination light at a second frequency.
2. A method of determining a chemical composition of a sample using an optical sensor, the method comprising:
 - generating an illumination light from a light source using a pulse width modulated voltage, wherein generating the illumination light comprises heating a resistively heated element of the light source to a temperature selected to emit black body radiation in a continuum spectral range;
 - collecting a sample light;
 - measuring the sample light with a detector;
 - the detector producing a signal that is representative of the measured sample light; and
 - processing circuitry determining, based on the signal, a chemical component in the sample; wherein the pulse width modulated voltage comprises a plurality of pulses having a first frequency, and a duty cycle,

12

wherein collecting a sample light further comprises directing the sample light to an Integrated Computational Element (ICE).

3. The method claim 2, further comprising:

- obtaining a first measurement at a first temperature and a second measurement at a second temperature; and
- determining a contrast value from the first measurement and the second measurement, the contrast value indicative of an analyte concentration in the sample.

4. The method of claim 3 wherein the contrast value comprises a difference in a measurement at a first wavelength and a measurement at a second wavelength.

5. The method of claim 3 wherein the contrast value comprises a ratio of a measurement at a first wavelength and a measurement at a second wavelength.

6. An optical sensor for determining a chemical composition of a sample, the optical sensor comprising:

- a light source comprising a resistively heated element;
- a power circuit configured to provide a pulse width modulated voltage signal to the resistively heated element to heat the resistively heated element to a temperature selected to emit black body radiation in a continuum spectral range;

- an optical delivery system to direct an illumination light to a sample;

- a sample cavity containing the sample and configured to receive the illumination light;

- an optical collection system to collect a sample light;

- a detector synchronized to the pulse width modulated voltage signal, the detector configured to measure the sample light from the optical collection system; and
- an Integrated Computational Element (ICE) to separate the sample light into a first light portion and a second light portion.

7. The optical sensor of claim 6, wherein the first light portion comprises a sample light reflected from the ICE; and the second light portion comprises a sample light transmitted from the ICE.

8. A method of determining a chemical composition of a sample using an optical sensor, the method comprising:

- generating an illumination light from a light source using a pulse width modulated voltage, wherein generating the illumination light comprises heating a resistively heated element of the light source to a temperature selected to emit black body radiation in a continuum spectral range;

- collecting a sample light;

- measuring the sample light with a detector, wherein a first portion of the sample light is measured with a first detector and a second portion of the sample light is measured with a second detector;

- the first detector producing a first signal that is representative of the sample light measured by the first detector;
- the second detector producing a second signal that is representative of the sample light measured by the second detector;

- processing circuitry determining, based on the first and second signals, a chemical component in the sample, wherein the pulse width modulated voltage comprises a plurality of pulses having a first frequency and a duty cycle;

- passing the illumination light through an optical modulator operating at a second frequency lower than the first frequency; and

synchronizing the two detectors to a combination frequency including a sum or a difference of the first frequency and the second frequency.

* * * * *