

US009506889B2

(12) **United States Patent**  
**Matsuura et al.**

(10) **Patent No.:** **US 9,506,889 B2**  
(45) **Date of Patent:** **Nov. 29, 2016**

(54) **BIOSENSOR AND BIOSENSOR MANUFACTURING METHOD**

(71) Applicant: **ARKRAY, INC.**, Kyoto (JP)

(72) Inventors: **Yoshimitsu Matsuura**, Kyoto (JP);  
**Shuzo Kanda**, Koka (JP)

(73) Assignee: **ARKRAY, INC.**, Kyoto (JP)

(\*) Notice: Subject to any disclaimer, the term of this patent is extended or adjusted under 35 U.S.C. 154(b) by 36 days.

(21) Appl. No.: **14/508,872**

(22) Filed: **Oct. 7, 2014**

(65) **Prior Publication Data**

US 2015/0041338 A1 Feb. 12, 2015

**Related U.S. Application Data**

(62) Division of application No. 13/180,016, filed on Jul. 11, 2011, now Pat. No. 8,920,747.

(60) Provisional application No. 61/363,467, filed on Jul. 12, 2010.

(30) **Foreign Application Priority Data**

Jul. 12, 2010 (JP) ..... 2010-158243  
Jul. 8, 2011 (JP) ..... 2011-151428

(51) **Int. Cl.**

**G01N 3/00** (2006.01)  
**G01N 33/00** (2006.01)

(Continued)

(52) **U.S. Cl.**

CPC .... **G01N 27/3272** (2013.01); **G01N 27/44743** (2013.01); **B01L 2300/08** (2013.01);

(Continued)

(58) **Field of Classification Search**

CPC ..... G01N 3/00; G01N 33/00; G01N 15/06; G01N 33/48; A61B 5/05  
USPC ..... 422/50, 68.1, 502, 503, 504, 420, 425, 422/430, 82.01, 507, 412; 435/283.1, 435/287.1, 287.7, 287.14; 600/300, 309, 600/316, 347, 365; 436/43, 180

See application file for complete search history.

(56) **References Cited**

U.S. PATENT DOCUMENTS

6,033,627 A 3/2000 Shields et al.  
6,143,164 A \* 11/2000 Heller et al. .... 600/583

(Continued)

FOREIGN PATENT DOCUMENTS

EP 1203956 A2 5/2002  
JP 2004-184180 A 7/2004

(Continued)

OTHER PUBLICATIONS

An Office Action; "Notice of Reasons for Rejection," issued by the Japanese Patent Office on Aug. 6, 2013, which corresponds to Japanese Patent Application No. 2011-151428 and is related to U.S. Appl. No. 13/180,016; with translation.

(Continued)

*Primary Examiner* — Brian J Sines

(74) *Attorney, Agent, or Firm* — Studebaker & Brackett PC

(57) **ABSTRACT**

A biosensor manufacturing method including a sheet material forming process and a dicing process. In the sheet material forming process a sheet material with plural biosensor forming sections is formed. Each of the biosensor forming sections includes a first base plate, a second base plate stacked on the first base plate and forming a capillary between the second base plate and the leading end portion of the first base plate for sucking in sample liquid, and a hydrophilic layer formed on the second base plate at least in a region facing the capillary. In the dicing process plural biosensors are obtained by dicing the sheet material with a blade from the first base plate side at the leading end of each of the biosensor forming sections, such that the leading end of the capillary opens onto the leading end face of the first base plate and the second base plate.

**7 Claims, 7 Drawing Sheets**

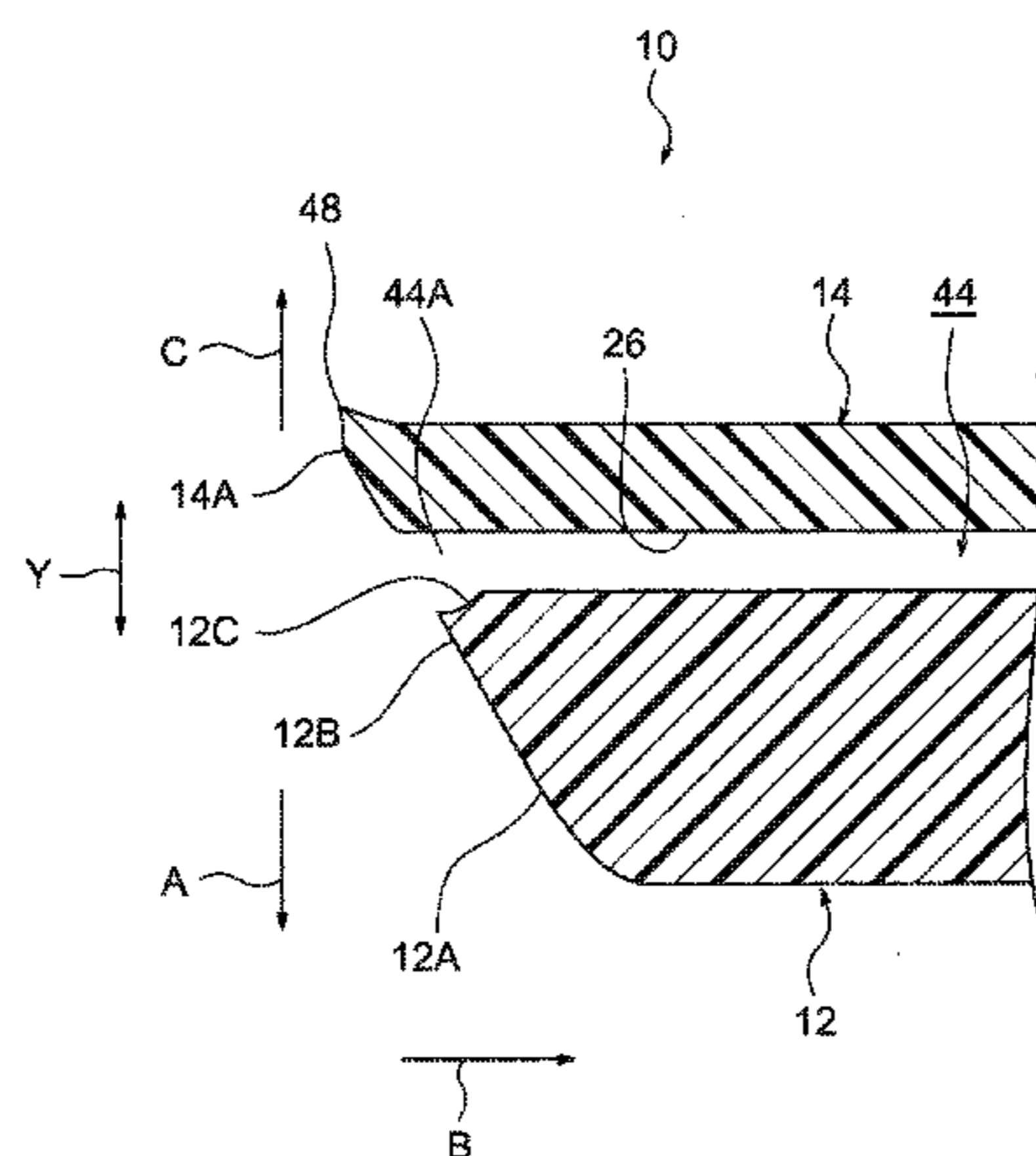

- (51) **Int. Cl.**  
*G01N 15/06* (2006.01)  
*G01N 33/48* (2006.01)  
*A61B 5/05* (2006.01)  
*G01N 27/327* (2006.01)  
*G01N 27/447* (2006.01)  
*G01N 21/03* (2006.01)  
*G01N 35/00* (2006.01)
- (52) **U.S. Cl.**  
 CPC ... *B01L2300/0825* (2013.01); *B01L 2300/161*  
 (2013.01); *B01L 2400/0406* (2013.01); *G01N*  
*2021/0346* (2013.01); *G01N 2035/00108*  
 (2013.01); *Y10T 156/1052* (2015.01); *Y10T*  
*436/25* (2015.01)

(56) **References Cited**  
 U.S. PATENT DOCUMENTS

6,299,757 B1 \* 10/2001 Feldman et al. .... 205/775  
 6,767,440 B1 \* 7/2004 Bhullar et al. .... 204/403.01  
 6,773,564 B1 \* 8/2004 Yugawa et al. .... 204/403.14  
 7,312,042 B1 12/2007 Petyt et al.  
 7,955,484 B2 \* 6/2011 Cai et al. .... 204/403.04  
 8,007,645 B2 8/2011 Yamanishi et al.  
 2002/0100684 A1 8/2002 Bhullar et al.  
 2002/0157947 A1 \* 10/2002 Rappin et al. .... 204/403.01

2003/0094384 A1 \* 5/2003 Vreeke et al. .... 205/777.5  
 2003/0116447 A1 \* 6/2003 SurrIDGE et al. .... 205/777.5  
 2003/0175841 A1 \* 9/2003 Watanabe et al. .... 435/14  
 2003/0178302 A1 \* 9/2003 Bhullar et al. .... 204/403.01  
 2004/0065562 A1 \* 4/2004 Hodges ..... 205/789  
 2004/0194302 A1 \* 10/2004 Bhullar et al. .... 29/847  
 2004/0200721 A1 \* 10/2004 Bhullar et al. .... 204/403.01  
 2005/0098433 A1 5/2005 Gundel  
 2006/0057740 A1 3/2006 Hiroshi et al.  
 2008/0101983 A1 5/2008 Petyt et al.  
 2010/0078322 A1 4/2010 Yamanishi et al.  
 2013/0031772 A1 2/2013 Petyt et al.

FOREIGN PATENT DOCUMENTS

JP 3672525 B2 7/2005  
 JP 2007-003361 A 1/2007  
 JP 2008-175795 A 7/2008  
 JP 2009-229469 A 10/2009  
 JP 2010-507805 A 3/2010

OTHER PUBLICATIONS

An Office Action issued by the Korean Patent Office on Feb. 23, 2015, which corresponds to Korean Patent Application No. 10-2014-0181687 and is related to U.S. Appl. No. 14/508,872.

\* cited by examiner

FIG. 1

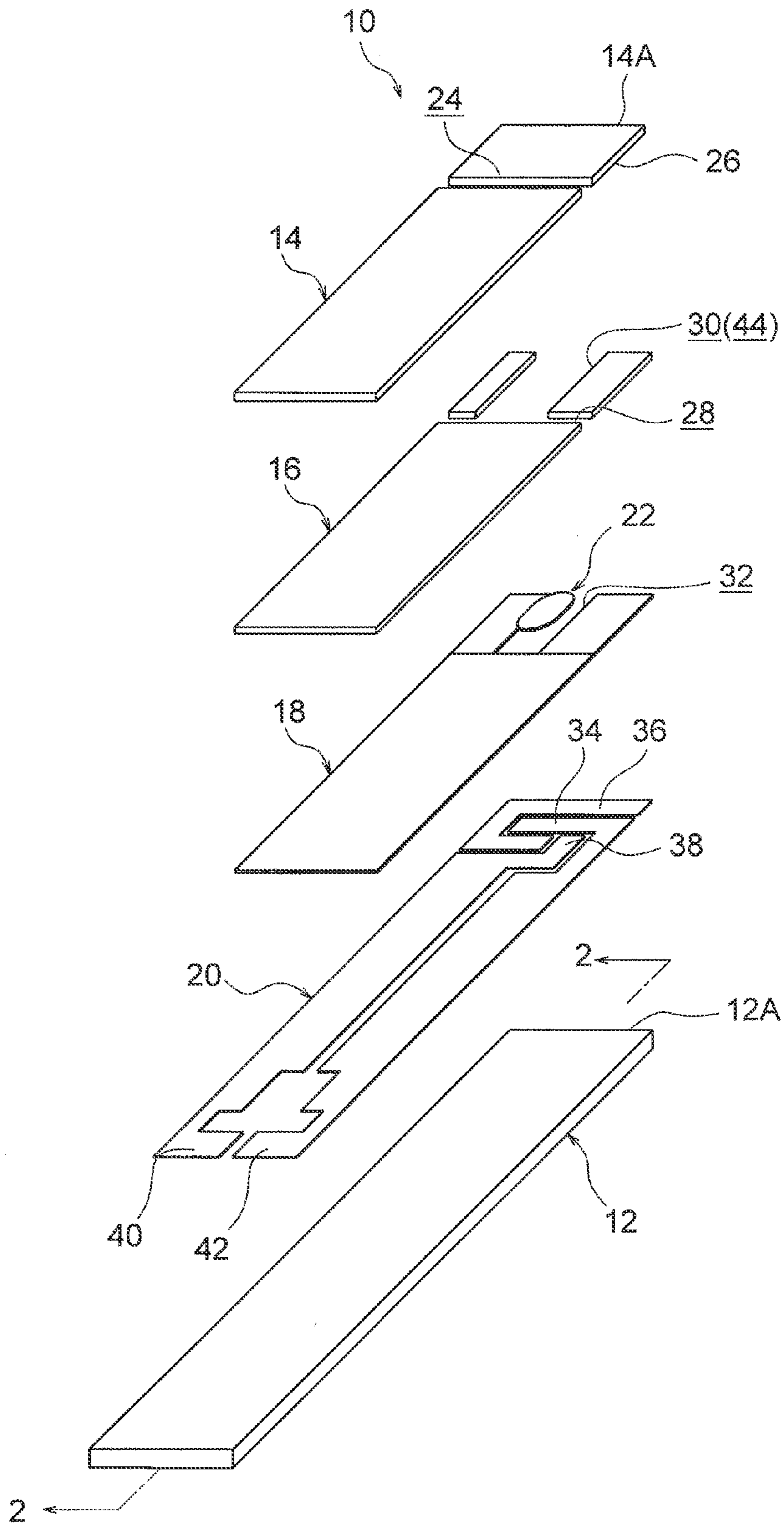

FIG.2

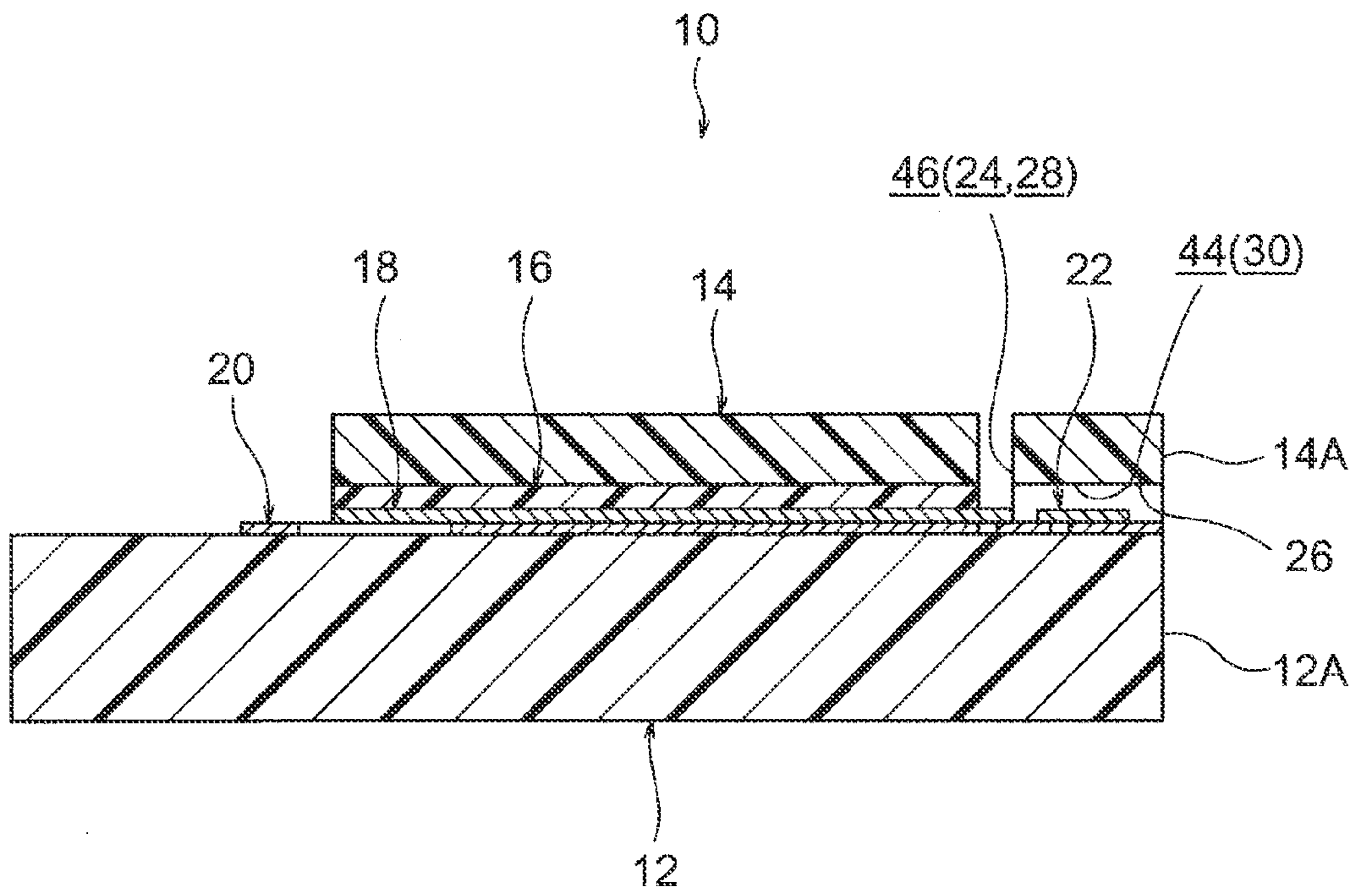

FIG.3

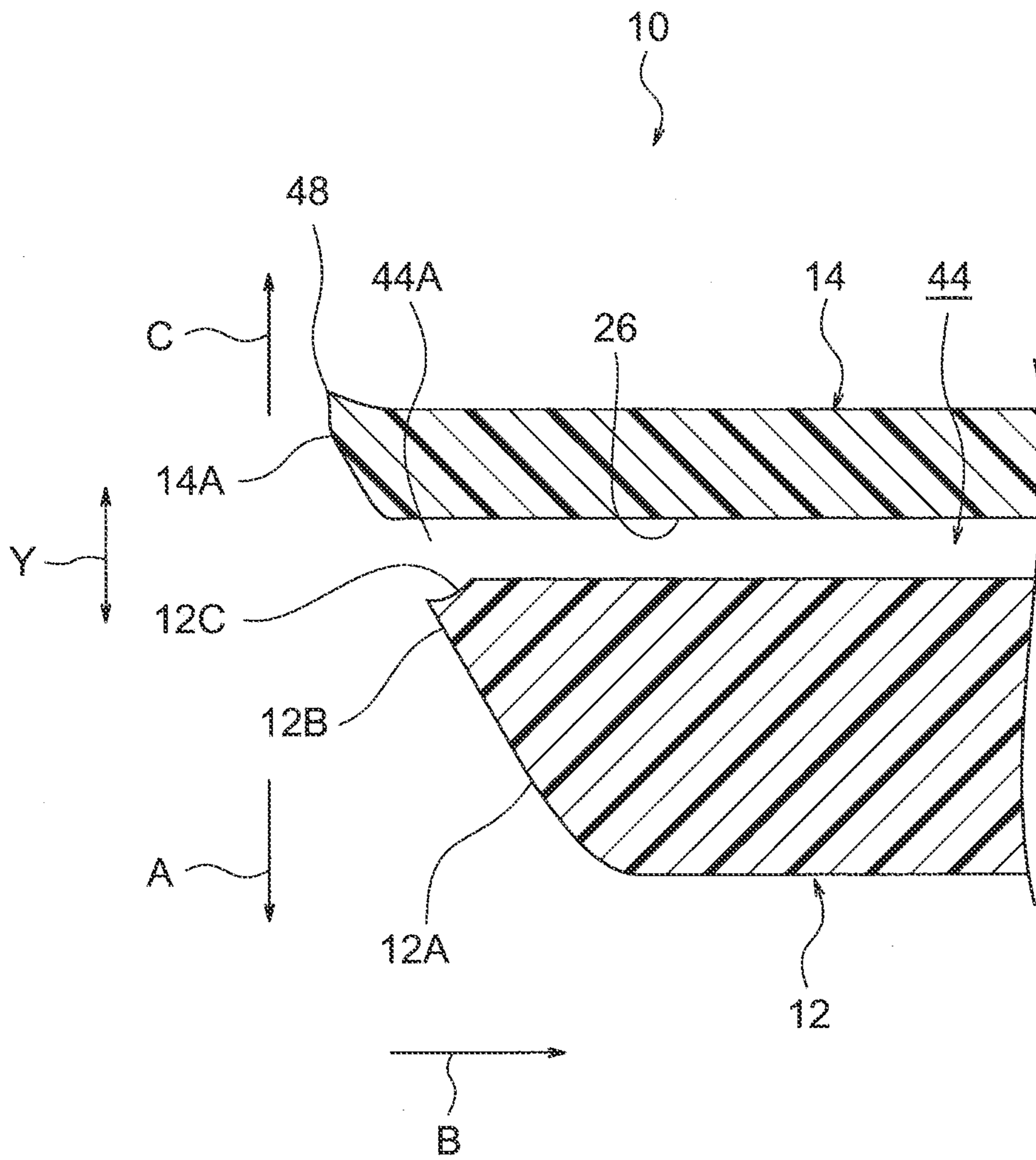

FIG.4

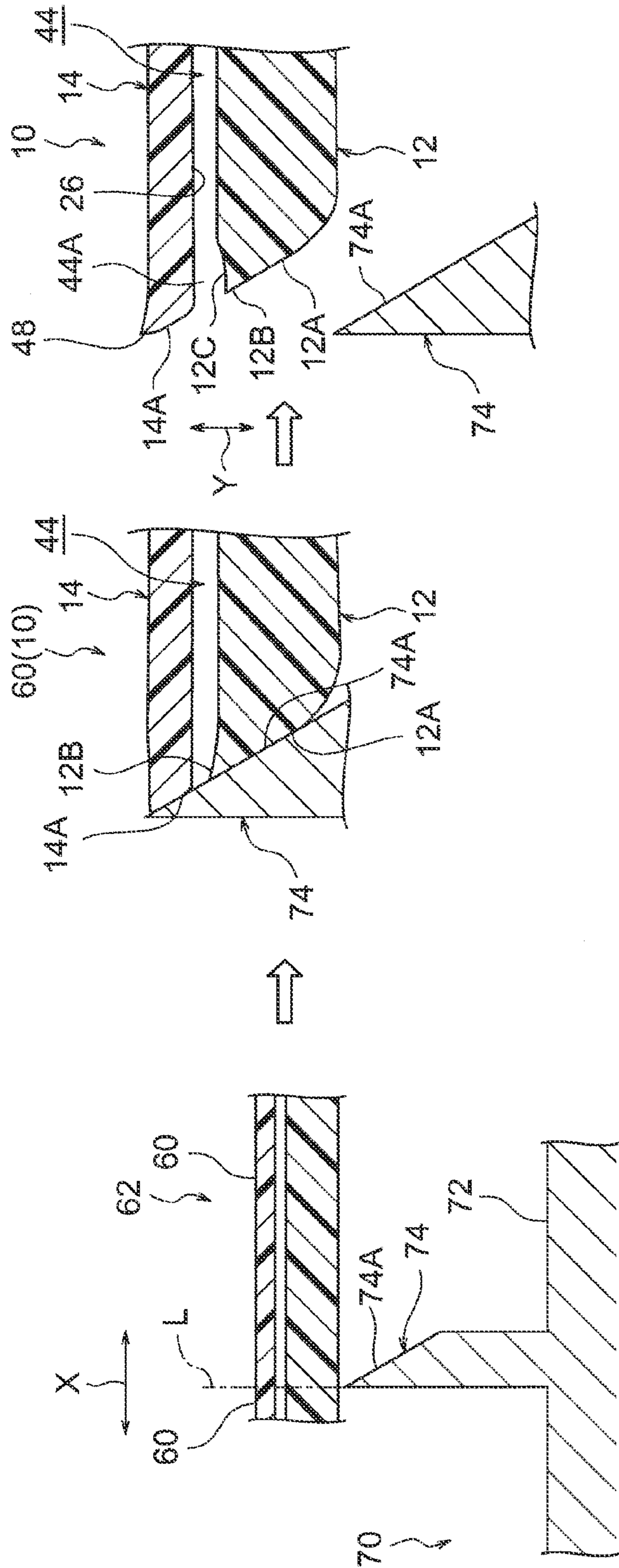

FIG. 5

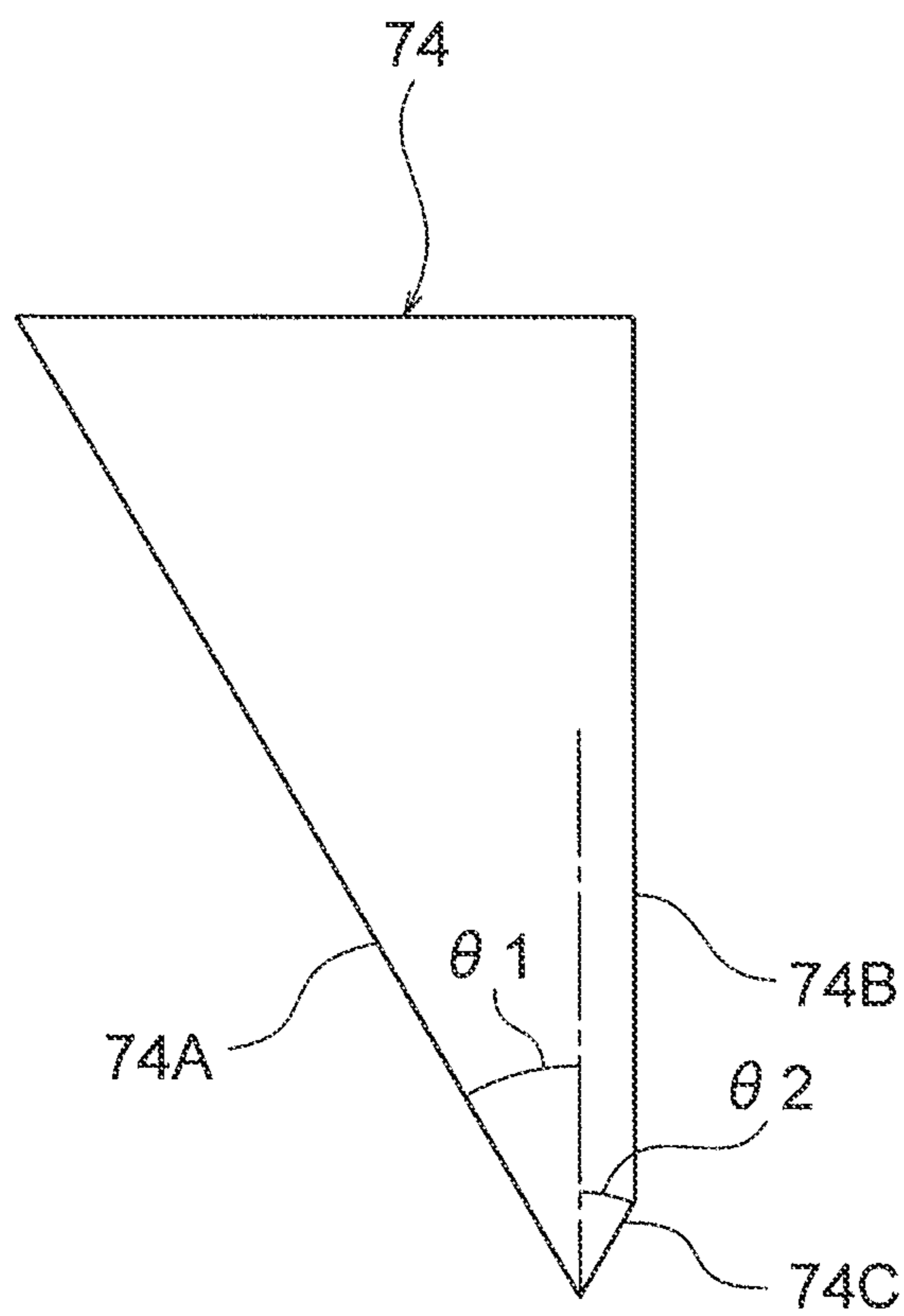

FIG. 6

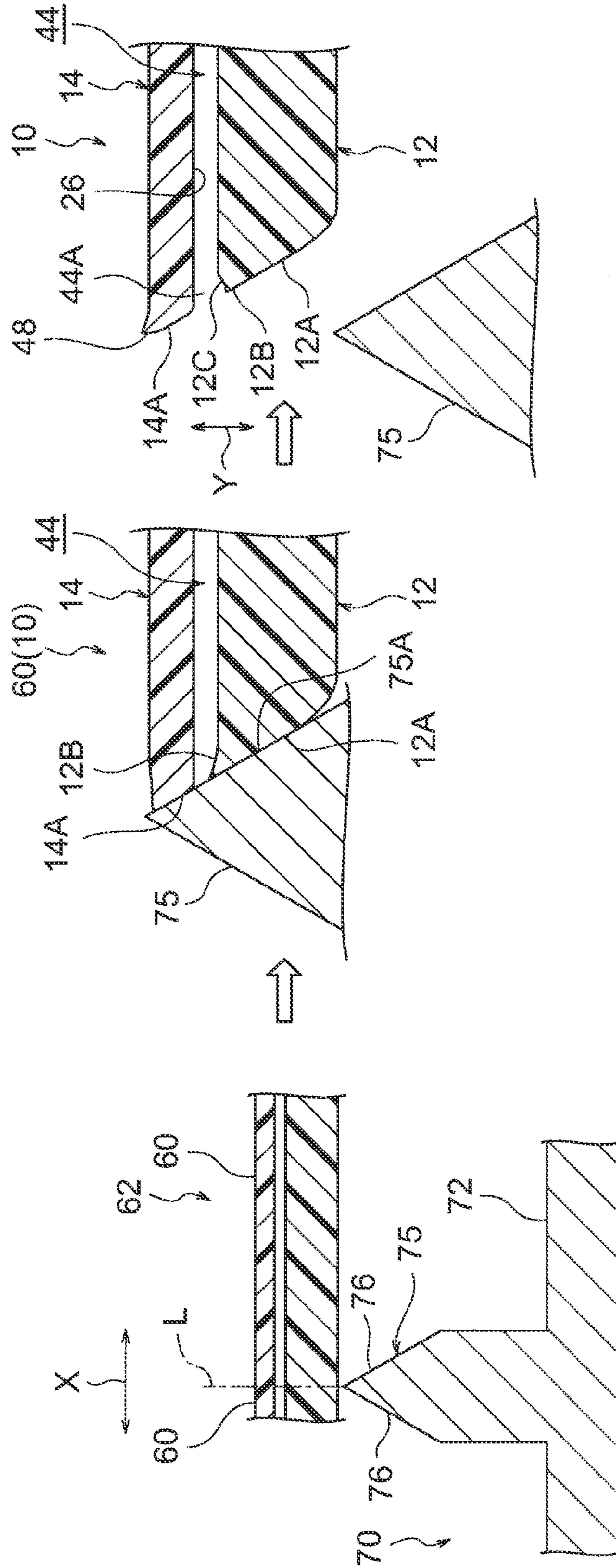
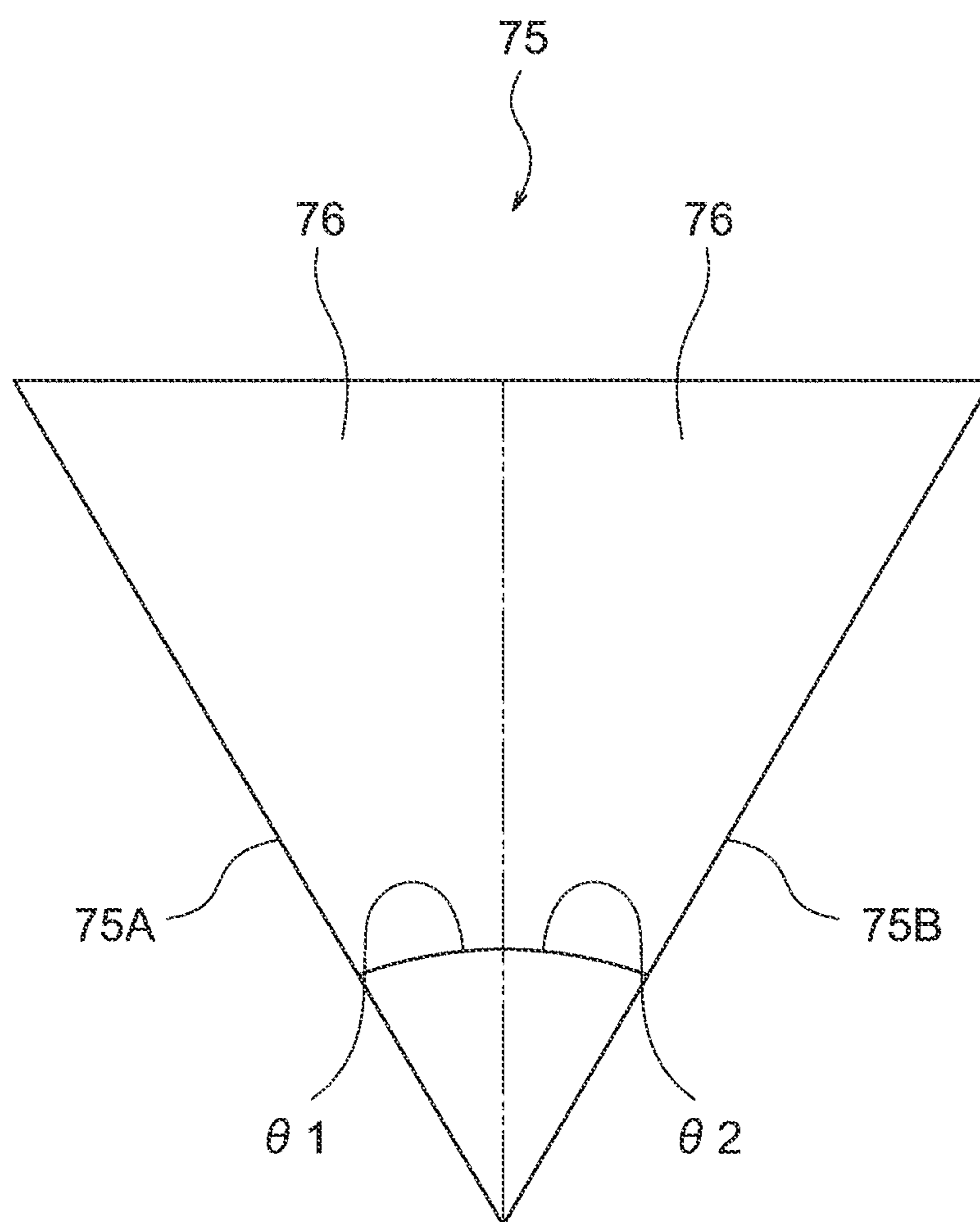



FIG.7



**BIOSENSOR AND BIOSENSOR  
MANUFACTURING METHOD**CROSS-REFERENCE TO RELATED  
APPLICATION

This application is a divisional of U.S. patent application Ser. No. 13/180,016 filed Jul. 11, 2011 which is based on and claims priority under 35 USC 119 from Japanese Patent Application No. 2010-158243 filed on Jul. 12, 2010, Japanese Patent Application No. 2011-151428 filed on Jul. 8, 2011, and U.S. Provisional Application No. 61/363,467 filed on Jul. 12, 2010, which are incorporated by reference herein.

## BACKGROUND

## Technical Field

The present invention relates to a biosensor and to a biosensor manufacturing method.

## Related Art

A biosensor is described in Japanese Patent Application Laid-Open (JP-A) No. 2007-3361 that is configured with a first insulating base plate and a second insulating base plate stuck onto the first insulating base plate and forming a capillary between the second insulating base plate and a leading end portion of the first insulating base plate for sucking in a sample liquid.

In the field of such types of biosensor a known biosensor manufacturing method obtains plural biosensor by dicing a sheet material. Traditionally in such a biosensor manufacturing method a blade is inserted from the second insulating base plate side so as to obtain plural biosensors.

However, in such cases a burr is formed on the second insulating base plate projecting out towards the capillary side, leading to concern of a drop in capillary sucking ability.

## SUMMARY

The present invention is made in consideration of the above issue, and is directed towards a biosensor and biosensor manufacturing method capable of securing the sucking ability of the capillary.

A biosensor manufacturing method according to an aspect of the invention includes: a sheet material forming process that forms a sheet material with a plurality of biosensor forming sections, each of the biosensor forming sections including a first base plate, a second base plate stacked on the first base plate and forming a capillary between the second base plate and a leading end portion of the first base plate for sucking in sample liquid, and a hydrophilic layer formed on the second base plate at least in a region facing the capillary; and a dicing process to obtain a plurality of biosensors by dicing the sheet material with a blade from the first base plate side at the leading end of each of the biosensor forming sections, such that a leading end of the capillary opens onto the leading end face of the first base plate and the second base plate.

According to the above biosensor manufacturing method, due to the blade being inserted from the first base plate side, the opposite side to the second base plate formed with the hydrophilic layer, the burr on the second base plate induced during dicing can be suppressed from projecting out to the hydrophilic layer side. Delamination or damage to the hydrophilic layer can accordingly be suppressed from occurring during dicing, and the sucking ability of the capillary can be secured.

In the above biosensor manufacturing method, a first base plate with a higher toughness than the second base plate may be employed for the first base plate in the sheet material forming process.

5 According to the above biosensor manufacturing method, a first base plate of higher toughness than the second base plate is employed as the first base plate, and hence burring can be suppressed from occurring from the first base plate on the capillary side when the blade is inserted from the first base plate side. Obstacles to the sample liquid being sucked up by the capillary can be eliminated or reduced, and hence sucking ability of the capillary can be better secured.

10 However, the leading end portion of the first base plate is deformed towards the second base plate side when the blade is inserted from the first base plate side. Then, when the blade has been removed, the leading end portion of the first base plate returns towards its original shape. The face on the capillary side of the leading end portion of the first base plate accordingly slopes away from the second base plate on progression towards the leading end. The leading end side of the capillary is accordingly imparted with a cross-section dimension in the direction of stacking the first base plate and the second base plate that widens on progression towards the leading end. Consequently, even when the amount of sample liquid is small, for example, the sample liquid can be readily spotted on the leading end of the capillary, and the sample liquid can be sucked into the capillary without problems.

15 In the above biosensor manufacturing method, the leading end of each of the biosensor forming sections may be diced so that the leading end face of the first base plate is a face sloping toward a rear end side of the first base plate on progression away from the second base plate.

20 According to the above biosensor manufacturing method, the leading end face of the first base plate is configured with a face sloping towards the rear end side of the first base plate on progression away from the second base plate. The sample liquid is hence readily placed in contact with the hydrophilic layer when the sample liquid is being sucked up by the capillary, enabling the sample liquid to be sucked up into the capillary without problems.

25 In the above biosensor manufacturing method, a single faced blade may be employed as the blade in the dicing process, the single faced blade including a contact face for contact with the leading end faces of the first base plate and the second base plate configured as a face sloping towards the rear end side of the first base plate on progression from the second base plate towards the first base plate side.

30 According to the above biosensor manufacturing method, a single faced blade is employed with a contact face that makes contact with the leading end faces of the first base plate and the second base plate, and is a face sloping towards the rear end side of the first base plate on progression from the second base plate side towards the first base plate side. The leading end face of the first base plate can accordingly be placed after dicing further to the rear end side of the second base plate than the leading end face of the second base plate, with insertion of the blade also from the first base plate side. Consequently, interference can be suppressed between the holding body holding the sample liquid and the leading end face of the first base plate when the sample liquid is being sucked into the capillary, enabling the sample liquid to be sucked up into the capillary without problems.

35 In the above biosensor manufacturing method, a double faced blade may be employed as the blade in the dicing process, the double faced blade comprising a pair of blade portions next to each other along an array direction of a pair of biosensor forming sections to be diced.

According to the above biosensor manufacturing method, a double faced blade is employed as the blade, and the blade is also inserted from the first base plate side. The leading end face of the first base plate can accordingly be placed after dicing further to the rear end side of the second base plate than the leading end face of the second base plate. Consequently, interference can be suppressed between the holding body holding the sample liquid and the leading end face of the first base plate when the sample liquid is being sucked into the capillary, enabling the sample liquid to be sucked up into the capillary without problems.

According to another aspect, a biosensor includes: a first base plate; a second base plate stacked on the first base plate and forming a capillary between the second base plate and a leading end portion of the first base plate that is for sucking in a sample liquid; a hydrophilic layer formed on the second base plate at least in a region facing the capillary; and a burr extending out from the second base plate on the side away from the capillary.

According to the above biosensor, the burr is formed on the second base plate as the first base plate and the second base plate are being diced by the blade. The burr extends out from the opposite side of the second base plate to that of the capillary due to inserting the blade from the first base plate side. The burr on the second base plate can accordingly be suppressed from projecting out to the capillary side of the second base plate, this being the hydrophilic layer side. The sucking ability of the capillary can hence be secured.

In the above biosensor, the first base plate may be formed with higher toughness than the second base plate.

According to the above biosensor the first base plate has higher toughness than the second base plate. Accordingly, generation of a burr from the first base plate towards the capillary side can be suppressed when the blade is inserted from the first base plate side. Consequently, obstacles to the sample liquid being sucked up by the capillary can be eliminated or reduced. Consequently, sucking ability of the capillary can be better secured.

In the above biosensor, the leading end side of the capillary may have a cross-section dimension, in the direction of stacking the first base plate and the second base plate, which gets wider on progression toward the leading end.

According to the above biosensor, the cross-section dimension at the leading end side of the capillary in the direction of stacking the first base plate and the second base plate widens on progression towards the leading end. Consequently, for example, even if there is only a small amount of the sample liquid, the sample liquid can be readily spotted on the leading end of the capillary, and the sample liquid can be sucked into the capillary without problems.

In the above biosensor, the leading end face of the first base plate may be formed as a face sloping toward a rear end side of the first base plate on progression way from the second base plate.

According to the above biosensor, the leading end face of the first base plate is configured with a face sloping towards the rear end side of the first base plate on progression away from the second base plate. The sample liquid is accordingly readily placed in contact with the hydrophilic layer when the sample liquid is being sucked in by the capillary, enabling the sample liquid to be sucked up into the capillary without problems.

In the above biosensor, the leading end face of the first base plate may be disposed further to a rear end side of the second base plate than a leading end face of the second base plate.

According to the above biosensor, the leading end face of the first base plate is placed after dicing further to the rear end side of the second base plate than the leading end face of the second base plate. Consequently, interference can accordingly be suppressed between the holding body holding the sample liquid and the leading end face of the first base plate when the sample liquid is being sucked into the capillary, enabling the sample liquid to be sucked up into the capillary without problems.

In the above biosensor, a region on the first base plate facing the capillary may have either a test reagent or an electrode present.

According to the above biosensor, fast mixing of the sample liquid with the test reagent can be achieved.

In the above biosensor a region of the first base plate facing the capillary may be also provided with a hydrophilic layer.

According to the above biosensor, the sample liquid arrives faster at the reaction region, enabling reaction and measurement to be accomplished in a short period of time.

In the above biosensor blood may be sucked in as the sample liquid. Moreover, the above biosensor may be employed for measuring a blood sugar value.

The above biosensor sample liquid sucking method may include: spotting a sample liquid onto a leading end side of the capillary, such that the sample liquid is caused to creep along a face of the second base plate on a side facing the first base plate, and also caused to creep along a face of the first base plate on a side facing the second base plate.

As explained in detail above, according to the present invention the suction ability of the capillary can be secured.

#### BRIEF DESCRIPTION OF THE DRAWINGS

An exemplary embodiment of the present invention will be described in detail based on the following figures, wherein:

FIG. 1 is an exploded perspective view of a biosensor according to an exemplary embodiment of the present invention;

FIG. 2 is a cross-section taken on line 2-2 of the biosensor illustrated in FIG. 1;

FIG. 3 is an enlarged cross-section of relevant portions at a leading end portion of the biosensor illustrated in FIG. 1;

FIG. 4 is an explanatory diagram of the flow of a manufacturing method for the biosensor illustrated in FIG. 1;

FIG. 5 is an enlarged diagram of the blade illustrated in FIG. 4;

FIG. 6 is an explanatory diagram of the flow in a modified example of a manufacturing method of the biosensor illustrated in FIG. 1; and

FIG. 7 is an enlarged diagram of the blade illustrated in FIG. 6.

#### DETAILED DESCRIPTION

Explanation follows regarding an exemplary embodiment of the present invention, with reference to the drawings.

A biosensor **10** according to an exemplary embodiment of the present invention, illustrated in FIG. 1 and FIG. 2, is, for example, a biosensor employed for taking and analyzing a sample liquid, such as blood. The biosensor **10** includes a first base plate **12**, a second base plate **14**, a spacer **16**, a resist **18**, a carbon electrode **20** and a test reagent **22**.

The first base plate **12** and the second base plate **14** are each formed in an elongated rectangular shape, with the first

base plate **12** formed with higher toughness than the second base plate **14**. In the present exemplary embodiment, as an example, the first base plate **12** is formed from a stretchable resin film, such as polybutylene terephthalate (PBT). The second base plate **14** is, for example, formed by a resin tape, such as polyethylene terephthalate (PET). The Izod impact strengths (un-notched) of PBT and PET are 1794 (J/m) and 686 (J/m), respectively. Thus when the first base plate **12** is formed from PBT and the second base plate **14** is formed from PET the first base plate **12** has a higher toughness than the second base plate **14**. A resin material is often employed for the material of the first base plate **12** (for example PBT, polyethylene terephthalate (PET), polycarbonate (PC), or polyvinyl alcohol (PVA)), however there is no limitation thereto. A resin material is often employed for the material of the second base plate **14** (for example PBT, PET, PC, or PVA) however there is no limitation thereto.

A slit **24** is formed at the leading end side of the second base plate **14**, extending along the width direction of the second base plate **14**. A hydrophilic layer **26** with hydrophilic properties is formed on the back face of the second base plate **14**. The hydrophilic layer **26** may be formed over the entire back face of the second base plate **14**, or may be formed locally in a region facing a capillary **44**, described later below. Namely it is sufficient for the hydrophilic layer **26** to be formed on at least on a region facing the capillary **44**. In the present exemplary embodiment the hydrophilic layer **26** is formed on the back face of the second base plate **14**. However, configuration may be made with a hydrophilic layer formed on a region of the first base plate **12** facing the second base plate **14**.

The spacer **16** is, for example, formed with double-sided adhesive tape extending along the second base plate **14**. A slit **28** is formed at the leading end side of the spacer **16**. The slit **28** is formed extending along the width direction of the spacer **16** at a location aligned with the slit **24**. A cutout **30** is also formed in the spacer **16** further towards the leading end side than the slit **28** and extending along the length direction of the spacer **16**. The cutout **30** is employed for configuring the capillary **44**, described later, and is open to the leading end of the spacer **16**.

The resist **18** is formed as a protective layer covering the front face of the carbon electrode **20**. A cutout **32** is formed at the leading end side of the resist **18** in a location aligned with the above cutout **30**. The carbon electrode **20** is configured with plural electrodes **34**, **36**, **38** and with leads **40**, **42**.

As shown from top to bottom in FIG. **2**, all of the members described above are stacked on each other in the sequence of: the second base plate **14**, the spacer **16**, the resist **18**, the carbon electrode **20**, and the first base plate **12**. When all of the members are stacked together in this state the capillary **44** is formed between leading end portions of the first base plate **12** and the second base plate **14** by the cutout **30**. The capillary **44** is open to the leading end faces **12A**, **14A** of the first base plate **12** and the second base plate **14**, respectively, and the capillary **44** also opens to the outside through an air gap **46** formed by the slits **24**, **28**.

A portion of each of the electrodes **34**, **36**, **38** shown in FIG. **1** is exposed through the cutout **32** in the capillary **44**, and the test reagent **22** is placed in the capillary **44** so as to make contact with a portion of each of the electrodes **34**, **36**, **38**. Namely configuration is made such that in the region on the first base plate **12** facing the capillary **44** either the test reagent **22** or one of the electrodes **34**, **36**, **38** is present.

The biosensor **10** sucks in sample liquid from the leading end of the capillary **44** by utilizing capillary action and

hydrophilic attraction. When the sample liquid is introduced into the capillary **44** a change occurs in electrical properties due to a reaction between the sample liquid and the test reagent **22**. In an analysis method using the biosensor **10** the leads **40**, **42** are connected to a measurement instrument, and analysis of the sample liquid is performed by the measurement instrument detecting such changes in electrical properties.

Explanation follows regarding a manufacturing method for the biosensor **10** configured as described above, together with explanation of the characteristic configuration of the biosensor **10** achieved using this manufacturing method.

Namely, in the manufacturing method of the biosensor according to the exemplary embodiment of the present invention, as shown on the left hand side of FIG. **4**, first a sheet material **62** is formed with plural biosensor forming sections **60** that will become the base of the biosensor **10** (see FIG. **1**). The dotted line L illustrated on the left hand side of FIG. **4** indicates a boundary between biosensor forming sections **60**.

Each of the biosensor forming sections **60** is configured with the first base plate **12**, the second base plate **14**, the spacer **16**, the resist **18**, the carbon electrode **20** and the test reagent **22**, as illustrated in FIG. **1**. The first base plate **12** has imparted with higher toughness than the second base plate **14** by utilizing materials such as those of the examples given above. The above processes correspond to the sheet material forming process of the present invention.

The sheet material **62** is then diced. The following processes correspond to the dicing process of the present invention. A fabrication device **70** is employed in dicing the sheet material **62**, such as the one shown on the left hand side of FIG. **4**. The fabrication device **70** is configured with a mold **72** and a single blade **74** formed to the mold **72**. The blade **74** employs a single face blade, with a contact face **74A** that makes contact with the leading end faces **12A**, **14A** of the first base plate **12** and the second base plate **14**. The blade **74** is a face sloping towards the rear end side of the first base plate **12** on progression from the second base plate **14** side towards the first base plate **12** side. The blade **74** is, as shown in FIG. **5**, formed with a face **74B** on the opposite side of the blade **74** to the contact face **74A**. The face **74B** is parallel to the blade insertion direction. A reinforcement face **74C** is formed at the blade tip side of the contact face **74A**. In the present exemplary embodiment the blade tip angles  $\theta_1$ ,  $\theta_2$  of the blade **74** are, for example, formed at  $30^\circ$ . These angles  $\theta$  may be anything from  $5^\circ$  to  $50^\circ$ , are preferably from  $10^\circ$  to  $40^\circ$ , and are more preferably from  $15^\circ$  to  $30^\circ$ .

As shown at the center and on the right hand side of FIG. **4**, the sheet material **62** is diced by the blade **74** at the leading end of each of the biosensor forming sections **60** from the first base plate **12** side, such that the leading end of the capillary **44** is opened to the leading end faces **12A**, **14A** of the first base plate **12** and the second base plate **14**.

As shown at the center of FIG. **4**, the leading end portion **12B** of the first base plate **12** is deformed towards the second base plate **14** side when the blade **74** is inserted from the first base plate **12** side. Then, when the blade **74** has been removed, as shown on the right hand side of FIG. **4**, the leading end portion **12B** of the first base plate **12** returns towards its original shape. A face **12C** is thereby formed on the capillary **44** side of the leading end portion **12B** of the first base plate **12**. The face **12C** slopes away from the second base plate **14** on progression towards the leading end. The leading end side **44A** of the capillary **44** is accordingly imparted with a cross-section dimension in the direction of

stacking the first base plate **12** and the second base plate **14** (arrow Y direction) that widens in on progression towards the leading end.

As shown at the center of FIG. **4**, the blade **74** is inserted to cut in parallel to the direction of stacking of the first base plate **12** and the second base plate **14**. The contact face **74A** of the blade **74** is a sloping face inclined to the blade insertion direction. The leading end face **12A** of the first base plate **12** after dicing is accordingly formed as a sloping face that slopes towards the rear end side of the first base plate **12** (the arrow B direction in FIG. **3**) on progression away from the second base plate **14** (the arrow A direction in FIG. **3**).

Namely, the leading end of each of the biosensor forming sections **60** is diced such that the leading end face **12A** of the first base plate **12** configures a face sloping towards the rear end side of the first base plate **12** on progression away from the second base plate **14**.

Furthermore, as shown on the right hand side of FIG. **4**, a burr **48** is formed to the second base plate **14** as the first base plate **12** and the second base plate **14** are being diced with the blade **74** from the first base plate **12** side. The burr **48** is formed so as to project out towards the front in the insertion direction of the blade **74** (the arrow C direction side in FIG. **3**). Namely, the burr **48** project out from the second base plate **14** away from the capillary **44**.

By utilizing a single faced blade as described above as the blade **74**, after dicing the leading end face **12A** of the first base plate **12** is positioned further to the rear end side of the second base plate **14** than the leading end face **14A** of the second base plate **14** (the arrow B direction side in FIG. **3**) when the blade **74** is inserted from the first base plate **12** side.

Plural of the biosensors **10** are obtained from the sheet material **62** by performing the above.

Explanation follows next regarding operation and effect of the exemplary embodiment of the present invention.

As described in detail above, according to the biosensor manufacturing method of the exemplary embodiment of the present invention, by inserting the blade **74** from the first base plate **12** side, this being opposite side of the second base plate **14** to that formed with the hydrophilic layer **26**, the burr on the second base plate **14** induced during dicing can be suppressed from projecting out to the hydrophilic layer **26** side of the second base plate **14**. Delamination or damage to the hydrophilic layer **26** can accordingly be suppressed from occurring during dicing.

Namely, according to the biosensor **10** fabricated by the above manufacturing method, the burr **48** is formed on the second base plate **14** as the first base plate **12** and the second base plate **14** are being diced by the blade **74**. The burr **48** extends out from the opposite side of the second base plate **14** to that of the capillary **44** due to inserting the blade **74** from the first base plate **12** side. The burr **48** of the second base plate **14** can accordingly be suppressed from projecting out to the capillary **44** side of the second base plate **14**, this being the hydrophilic layer **26** side. The sucking ability of the capillary **44** can hence be secured.

In this biosensor manufacturing method the first base plate **12** is employed with higher toughness than the second base plate **14**. Accordingly, generation of a burr on the first base plate **12** towards the capillary **44** side can be suppressed when the blade **74** is inserted from the first base plate **12** side. Consequently, according to the biosensor **10** fabricated by the above manufacturing method, obstacles to the sample liquid being sucked up by the capillary **44** can be eliminated or reduced. Consequently, sucking ability of the capillary **44** can be better secured. Occurrences of poor sucking with the

biosensor are reduced as follows. The rate of poor sucking occurring is reduced from 42/8000 strips prior to widening structure change to 0/36740 strips after change.

According to the biosensor **10**, the cross-section dimension at the leading end side **44A** of the capillary **44** in the direction of stacking the first base plate **12** and the second base plate **14** widens on progression towards the leading end. Consequently, for example, even if there is only a small amount of the sample liquid, the sample liquid can be readily spotted on the leading end of the capillary **44**, and the sample liquid can be sucked into the capillary **44** without problems.

According to the biosensor manufacturing method, the leading end face **12A** of the first base plate **12** is configured with a face sloping towards the rear end side of the first base plate **12** on progression away from the second base plate **14**. According to the biosensor **10** fabricated by the above manufacturing method, the sample liquid is readily placed in contact with the hydrophilic layer **26** when the sample liquid is being sucked up by the capillary **44**, enabling the sample liquid to be sucked up into the capillary **44** without problems.

According to the biosensor manufacturing method, by employing a single faced blade like the one described above for the blade **74**, the leading end face **12A** of the first base plate **12** can be placed after dicing further to the rear end side of the second base plate **14** than the leading end face **14A**, with insertion of the blade **74** also from the first base plate **12** side. Consequently, according to the biosensor **10** fabricated by the above manufacturing method, interference can be suppressed between the holding body holding the sample liquid and the leading end face **12A** of the first base plate **12** when the sample liquid is being sucked into the capillary **44**, enabling the sample liquid to be sucked up into the capillary **44** without problems. The holding body referred to here corresponds, for example, to a fingertip when the sample liquid is a drop of blood on a fingertip.

The region of the first base plate **12** facing the capillary **44** is configured with either the test reagent **22** or the electrodes **34**, **36**, **38** present, enabling the sample liquid to be speedily mixed with the test reagent **22**.

Note that the faces on which the electrodes **34**, **36**, **38** are placed may also be provided with a hydrophilic layer. However, good transportation of the sample liquid is achieved when a hydrophilic layer is formed on the face opposing the electrodes **34**, **36**, **38**, or on both faces, by making the hydrophilicity of the face opposing the electrodes higher. Seedy mixing and even mixing with the test reagent **22** is thereby achieved, enabling accurate readings to be made in a short period of time.

A double faced blade **75** may be employed in the dicing process described above, as shown in FIG. **6**. The blade **75** has a pair of blade portions **76** next to each other along the array direction of a pair of biosensor forming sections **60** to be diced (the arrow X direction). As shown in FIG. **7**, the blade tip angles  $\theta 1$ ,  $\theta 2$ , are, for example, each formed at  $30^\circ$ , thereby providing the blade **75** with sloped faces **75A**, **75B** on both sides. These angles  $\theta 1$ ,  $\theta 2$  may be anything within the range from  $5^\circ$  to  $50^\circ$ , are preferably from  $10^\circ$  to  $40^\circ$ , and more preferably from  $15^\circ$  to  $30^\circ$ .

The double faced blade in the present invention is a blade formed with left-right symmetry in FIG. **6**, and the single faced blade in the present invention is formed as a blade that is asymmetrical in the left-right direction in FIG. **4**, with one of its faces configured as a face sloping with respect to the blade insertion direction.

Also when the blade **75** is inserted from the first base plate **12** side, as shown in FIG. **6**, the leading end face **12A** of the

first base plate **12** can be positioned further to the rear end side of the second base plate **14** than the leading end face **14A** of the second base plate **14**. Accordingly interference between the holding body for holding the sample liquid and the leading end face **12A** of the first base plate **12** when the sample liquid is being sucked into the capillary **44** can be suppressed, enabling the sample liquid to be sucked into the capillary **44** without problems.

The blade **74** can employ a single faced blade with its sloping face on the side facing towards the capillary **44**. However, when the blade **75** is employed the compression load from inserting the blade tip is more evenly dissipated than when a single faced blade is employed. The durability of the blade tip can accordingly be raised, and hence productivity when using the blade can also be raised. A reduction in cost can also be achieved by reducing blade changes caused by blade tip chipping, and by raising the durability of the blade.

The material used for the blade may, as an example be a metal, and treatment may be performed in order to raise the hardness and durability of the blade tip (for example quenching treatment, titanium treatment, diamond treatment), however there is no limitation thereto.

In comparison to processing by knocking out of a mold, the initial investment required is reduced since a complicated mold is not required, and the durability of the mold employed can be raised. Each of the manufacturing processes can also be simplified, and since there is no need to employ a high hardness blade this also enables a reduction in cost to be achieved.

By configuration with the hydrophilic layer formed on the first base plate **12** in the region facing the capillary **44** the sample liquid arrives at the reaction region faster, enabling reaction and measurement to be accomplished in a short period of time.

The sample liquid in the present invention includes, for example, a body fluid, and in particular blood and urine. Substances to be measured include, for example, substances such as glucose, lactic acid, cholesterol and uric acid. The structure of the above exemplary embodiment that increases suction force is particularly advantageous for viscous sample liquids in particular, such as blood. Due to the viscous nature of hematocrit and blood corpuscles affecting blood sugar measurements the structure of the above exemplary embodiment that increases suction force is useful for blood sugar value measurements.

The biosensor **10** of the present exemplary embodiment is preferably employed for sucking in blood as the sample liquid, and for measuring blood sugar values. Namely, while generally the viscosity of blood as the sample liquid can be accommodated, for blood sugar value measurements where there is a requirement for a particularly short response time the shape and characteristics of the biosensor configured as described above delivers an advantage.

Regarding the sample liquid sucking method of the biosensor **10**, preferably the sample liquid is spotted on the

leading end side **44A** of the capillary **44**, and the sample liquid is caused to creep along the face of the second base plate **14** on the first base plate **12** side and the sample liquid is also caused to creep along the face of the first base plate **12** on the second base plate **14** side.

The present invention is explained above by way of exemplary embodiments, however the present invention is not limited by the above, and obviously various modifications may be implemented within a range not departing from the spirit of the invention.

What is claimed is:

1. A biosensor comprising:

a first base plate having a leading end portion;  
a second base plate having a leading end portion, said second base plate stacked on the first base plate and forming a capillary between the leading end portion of the second base plate and the leading end portion of the first base plate that is for sucking in a sample liquid;  
a hydrophilic layer formed on the second base plate at least in a region facing the capillary; and  
wherein a region on the first base plate facing the capillary has either a test reagent or an electrode present; and  
wherein said second base plate has a projecting portion formed on the leading end portion thereof, said projecting portion extends out from the second base plate away from the capillary in a direction perpendicular to the second base plate.

2. The biosensor of claim 1, wherein the first base plate is formed with higher toughness than the second base plate.

3. The biosensor of claim 1, wherein the leading end side of the capillary has a cross-section dimension, in the direction of stacking the first base plate and the second base plate, which gets wider on progression toward the leading end.

4. The biosensor of claim 1, wherein the leading end face of the first base plate is formed as a face sloping toward a rear end side of the first base plate on progression way from the second base plate.

5. The biosensor of claim 1, wherein the leading end face of the first base plate is disposed further to a rear end side of the second base plate than a leading end face of the second base plate.

6. The biosensor of claim 1, wherein a region of the first base plate facing the capillary is also provided with a hydrophilic layer.

7. A biosensor sample liquid sucking method in which a sample liquid is sucked in by the biosensor of claim 1, the biosensor sample liquid sucking method comprising:

spotting a sample liquid onto a leading end side of the capillary, such that the sample liquid is caused to creep along a face of the second base plate on a side facing the first base plate, and also caused to creep along a face of the first base plate on a side facing the second base plate.

\* \* \* \* \*