

US009452692B1

(12) **United States Patent**
Rawlinson et al.

(10) **Patent No.:** **US 9,452,692 B1**
(45) **Date of Patent:** **Sep. 27, 2016**

(54) **MULTI-POSITION VEHICLE SEAT**

(56) **References Cited**

(71) Applicant: **Atieva, Inc.**, Menlo Park, CA (US)
(72) Inventors: **Peter Dore Rawlinson**, Worcestershire (GB); **Daniel Jefferson Muir**, San Carlos, CA (US)
(73) Assignee: **ATIEVA, INC.**, Menlo Park, CA (US)
(*) Notice: Subject to any disclaimer, the term of this patent is extended or adjusted under 35 U.S.C. 154(b) by 0 days.

U.S. PATENT DOCUMENTS

4,846,529	A *	7/1989	Tulley	B60N 2/0232 297/330
4,997,053	A *	3/1991	Drori	B60N 2/0224 180/268
8,182,014	B2 *	5/2012	Mabuchi	B60N 2/01 296/64
8,245,994	B2 *	8/2012	Yamada	B60N 2/073 248/424
9,114,733	B2 *	8/2015	Pluta	B60N 2/06
2007/0290554	A1 *	12/2007	Teshima	B60N 2/0244 307/10.1
2008/0312797	A1 *	12/2008	Takehisa	B60N 2/0244 701/49
2014/0138997	A1 *	5/2014	Schulz	B60N 2/0244 297/344.24

(21) Appl. No.: **14/706,008**
(22) Filed: **May 7, 2015**

* cited by examiner

(51) **Int. Cl.**
B60N 2/07 (2006.01)
B60N 2/14 (2006.01)
B60N 2/06 (2006.01)
B60N 2/02 (2006.01)
B60N 2/005 (2006.01)

Primary Examiner — Jason S Daniels
(74) *Attorney, Agent, or Firm* — Patent Law Office of David G. Beck

(52) **U.S. Cl.**
CPC **B60N 2/07** (2013.01); **B60N 2/005** (2013.01); **B60N 2/0232** (2013.01); **B60N 2/0244** (2013.01); **B60N 2/062** (2013.01); **B60N 2/14** (2013.01); **B60N 2002/0216** (2013.01)

(57) **ABSTRACT**

A seat mounting system is provided that allows a vehicle passenger seat, preferably a rear passenger seat mounted within the rear portion of the passenger cabin, to move laterally (i.e., side-to-side), fore-aft (i.e., forwards-backwards), and rotationally. As a result, an occupant of the passenger seat can optimize their seat position for the task at hand, e.g., relaxing, obtaining additional leg and/or shoulder room, rotating inwards during a conversation with others in the car, rotating outwards to aid vehicle egress, etc. Seat movement may be performed automatically or manually using dual track assemblies.

(58) **Field of Classification Search**
CPC B60N 2/02; B60N 2/0224; B60N 2/0228; B60N 2/0232; B60N 2/0244; B60N 2/0296; B60N 2/04; B60N 2/06; B60N 2/062; B60N 2/065; B60N 2/067; B60N 2/07; B60N 2/14
USPC 296/65.07, 65.08, 65.12, 65.13, 65.15
See application file for complete search history.

22 Claims, 9 Drawing Sheets

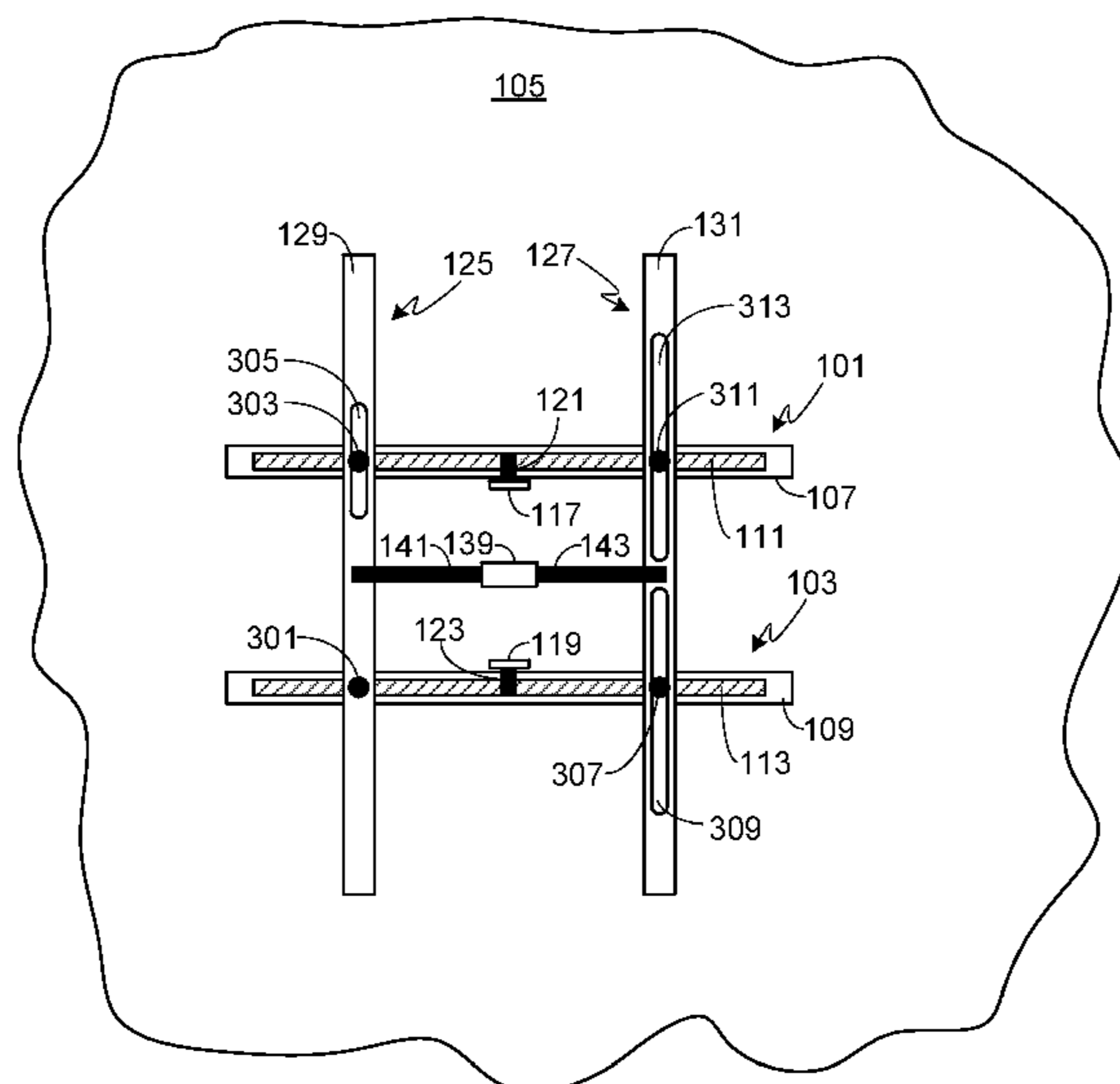

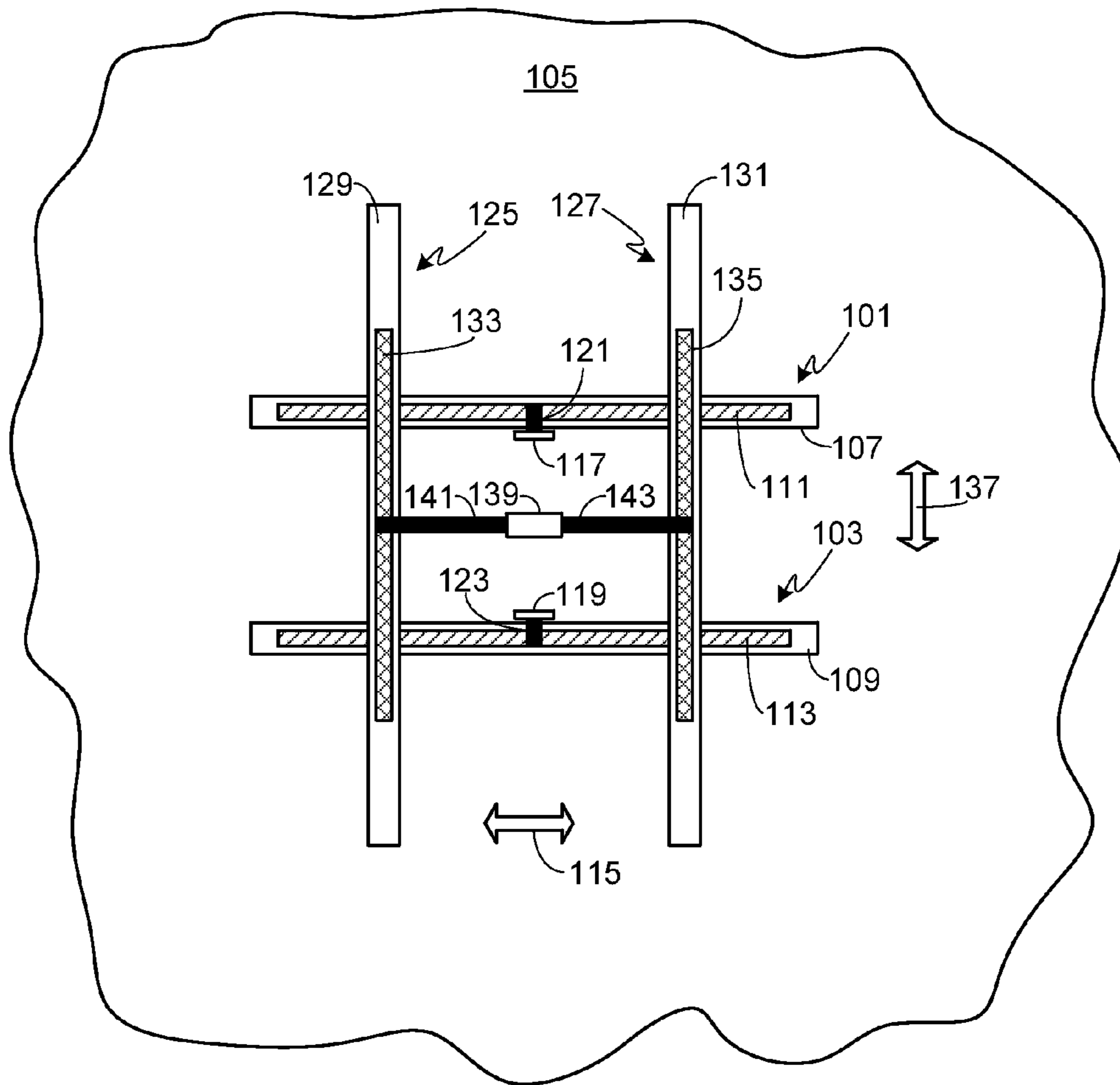

FIG. 1

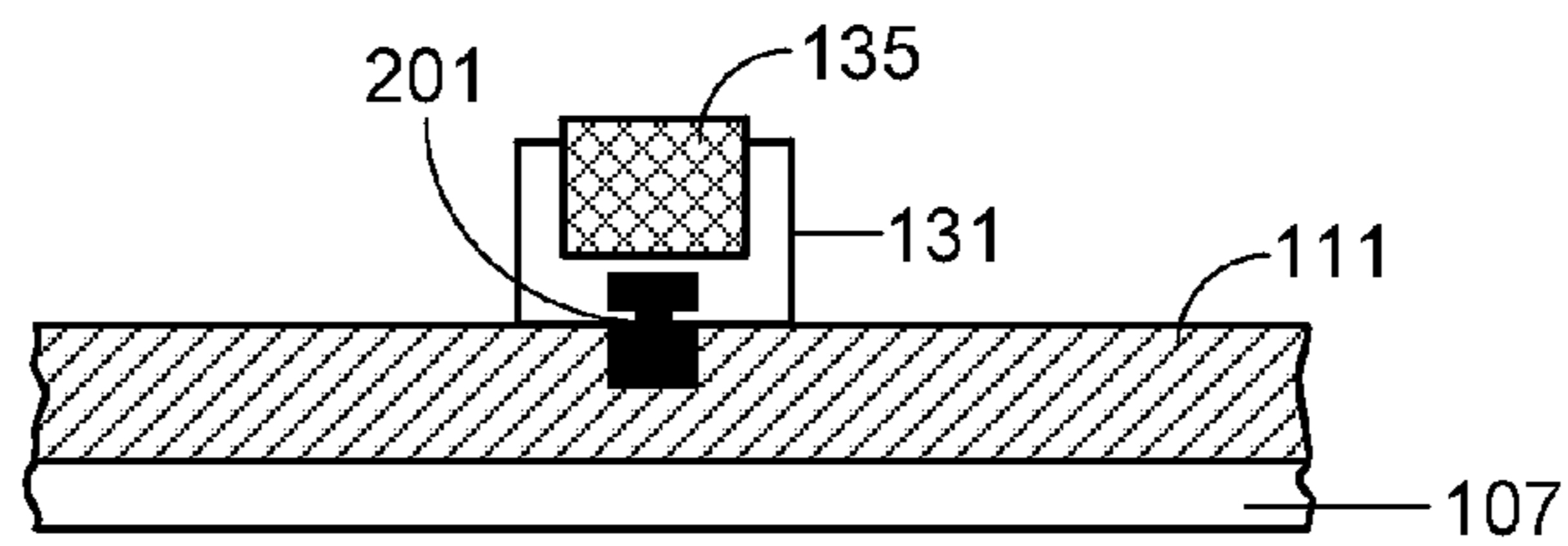

FIG. 2

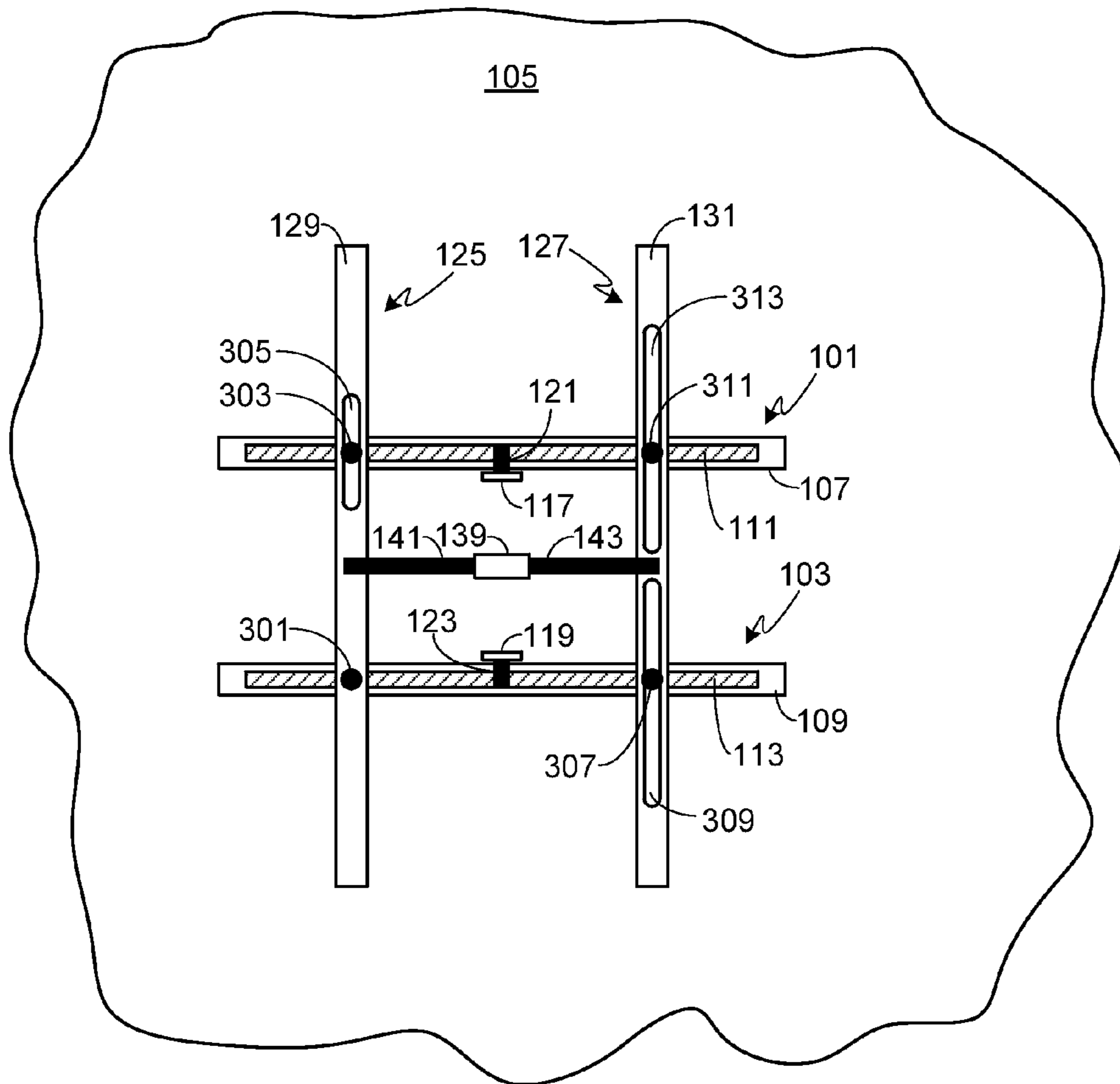

FIG. 3

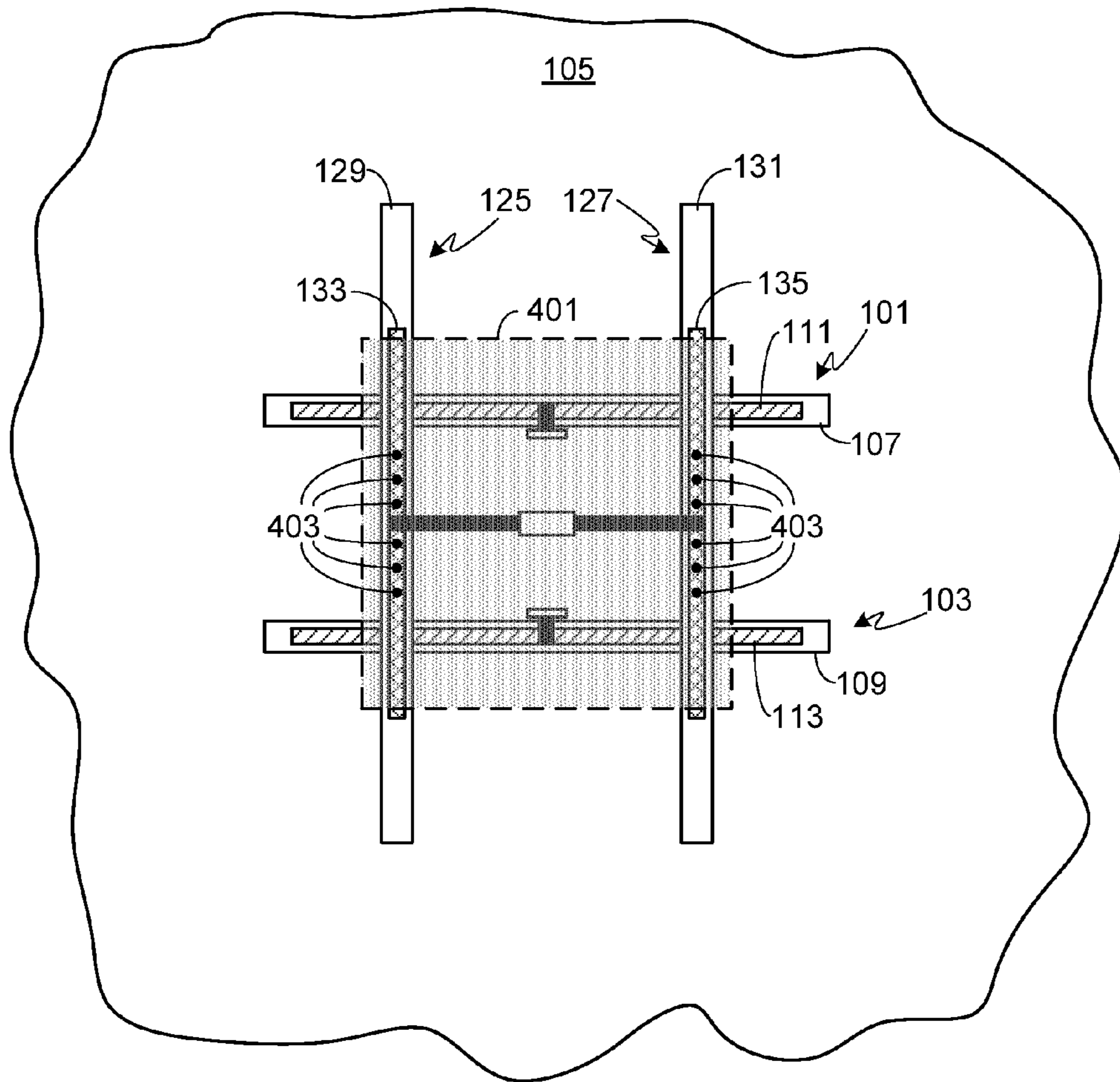

FIG. 4

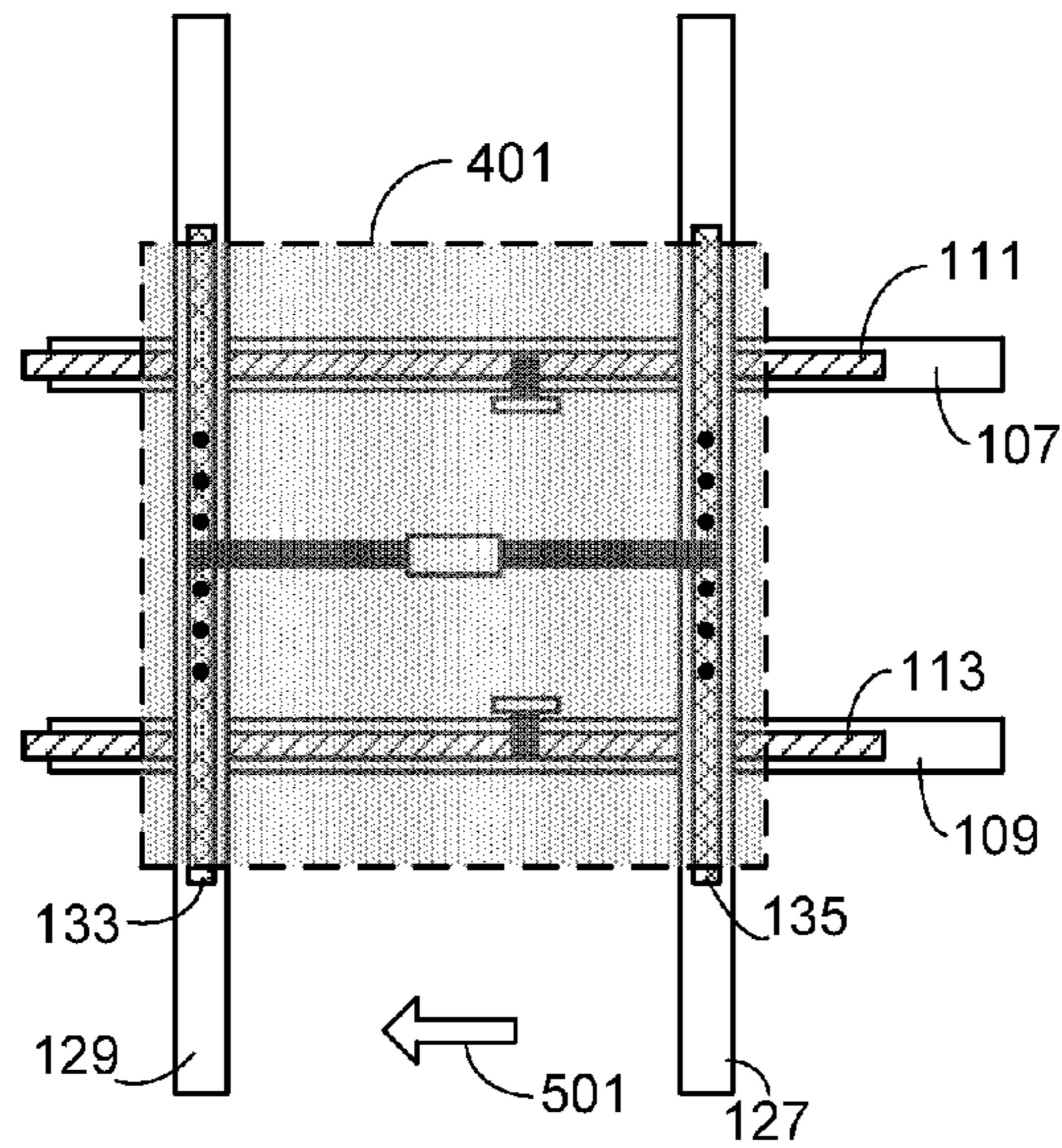

FIG. 5

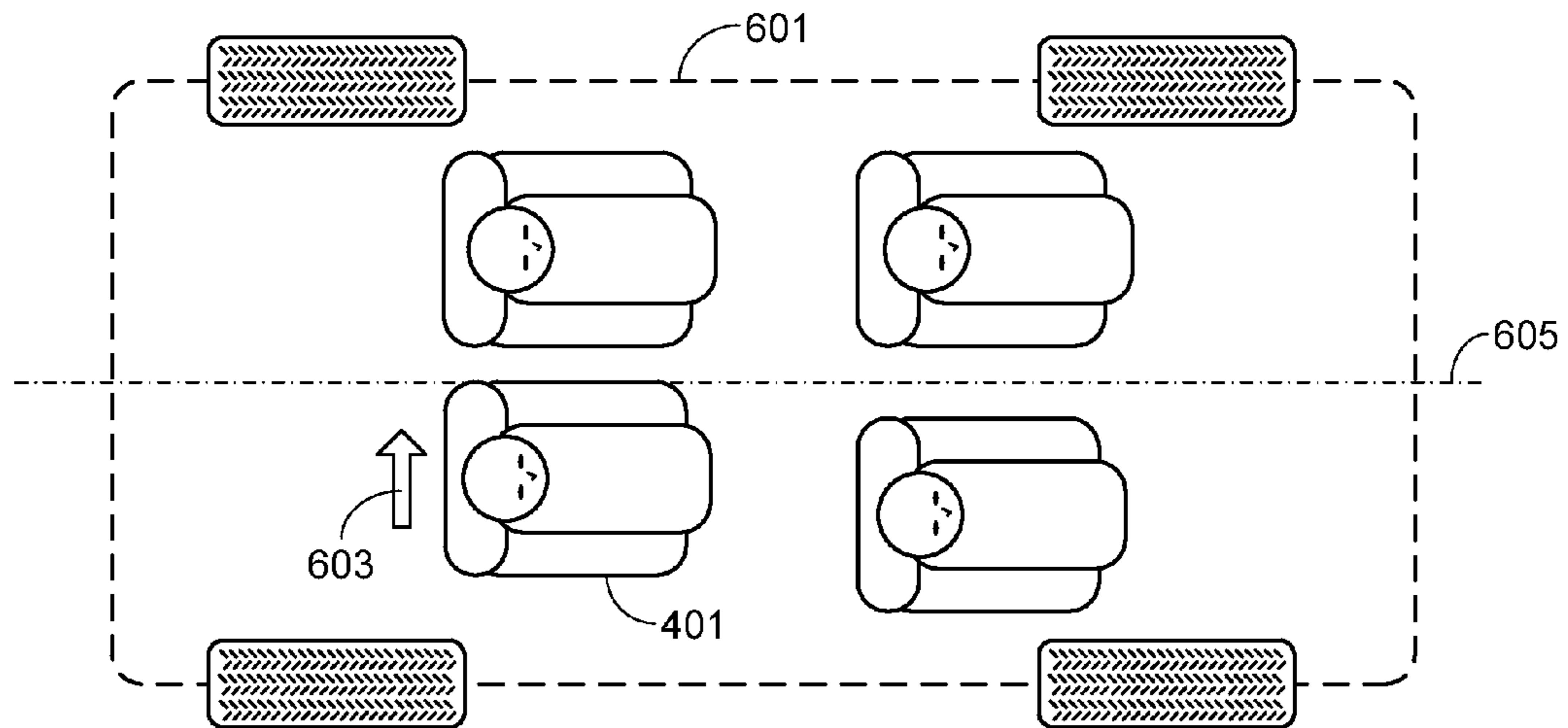

FIG. 6

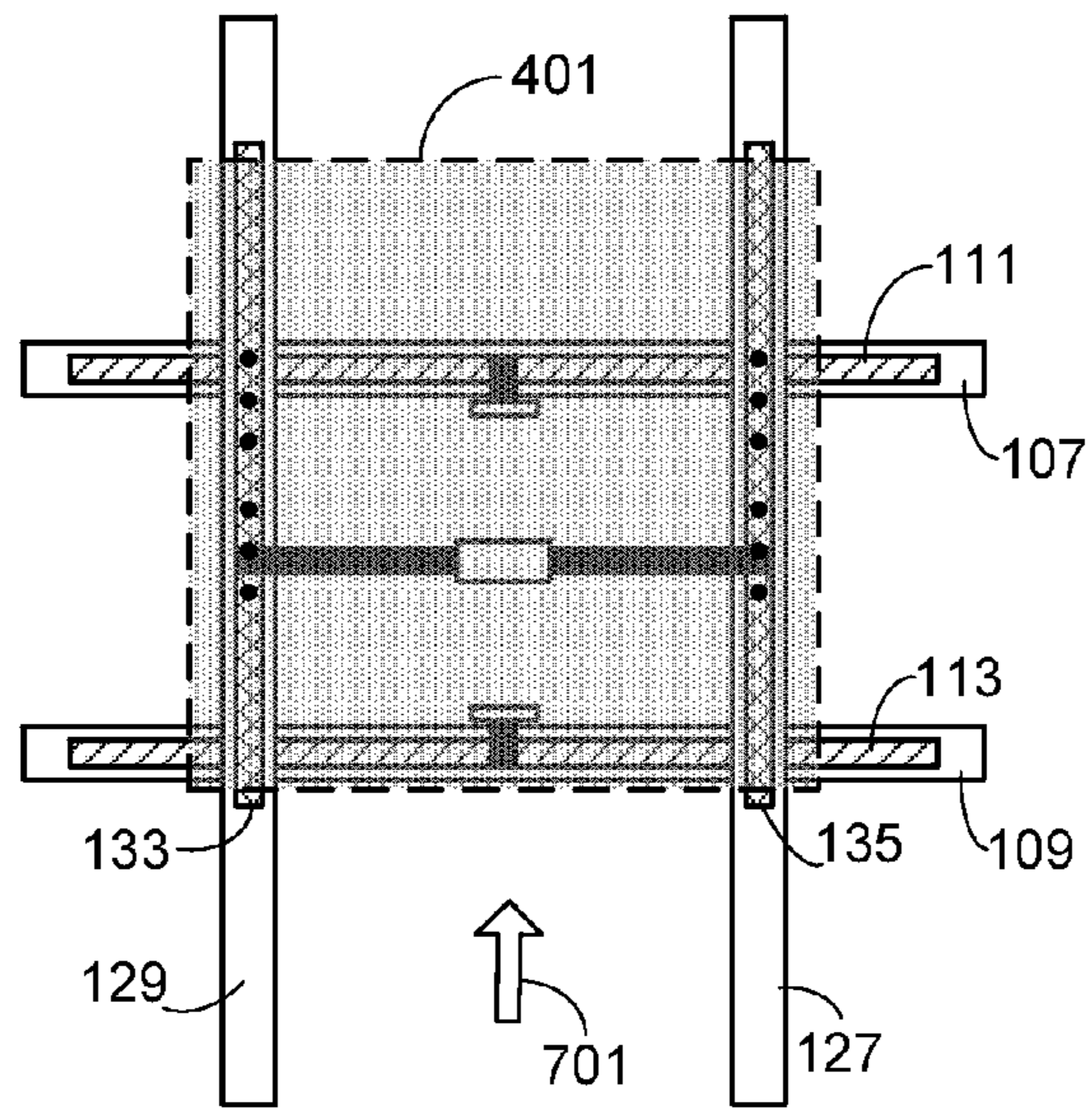

FIG. 7

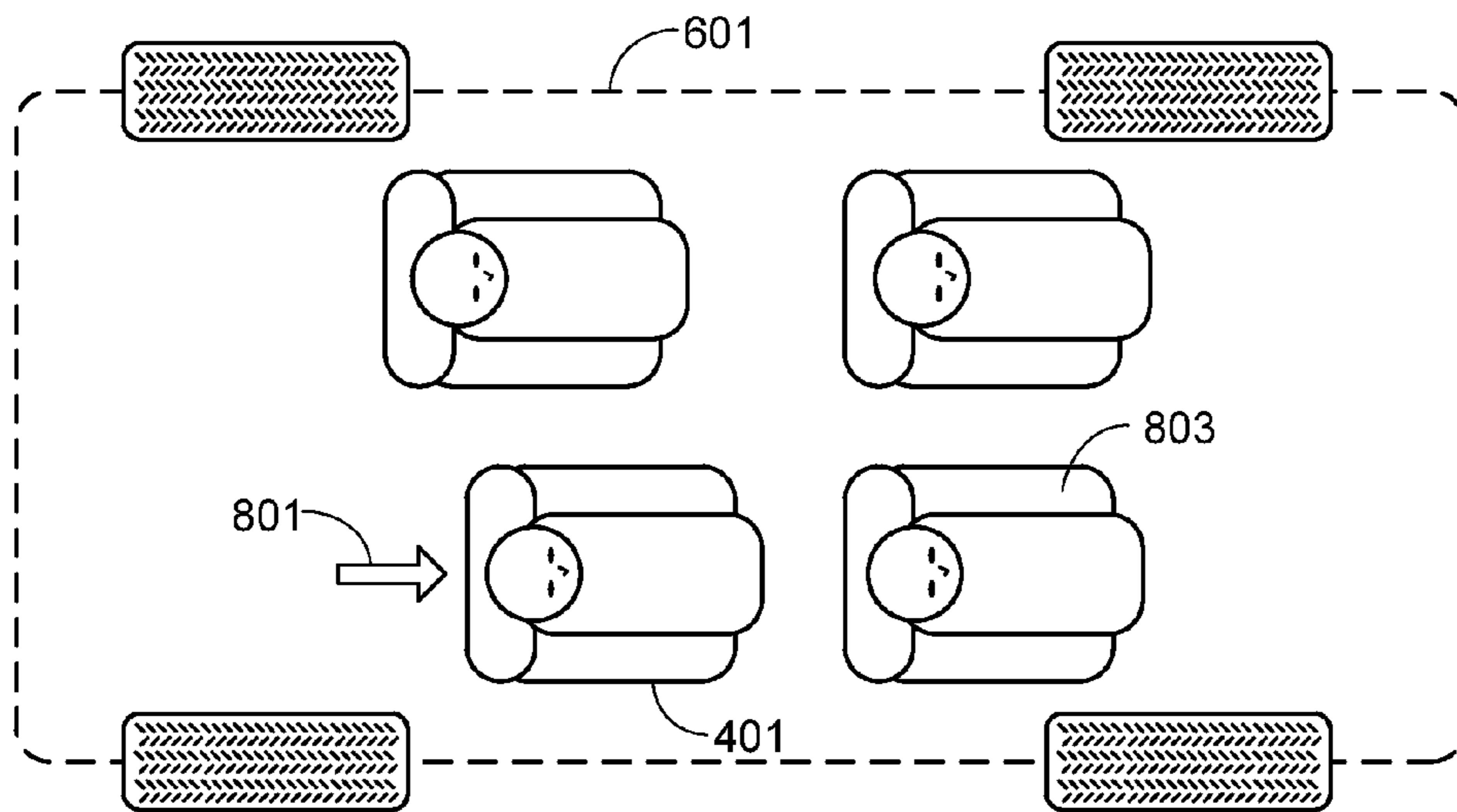

FIG. 8

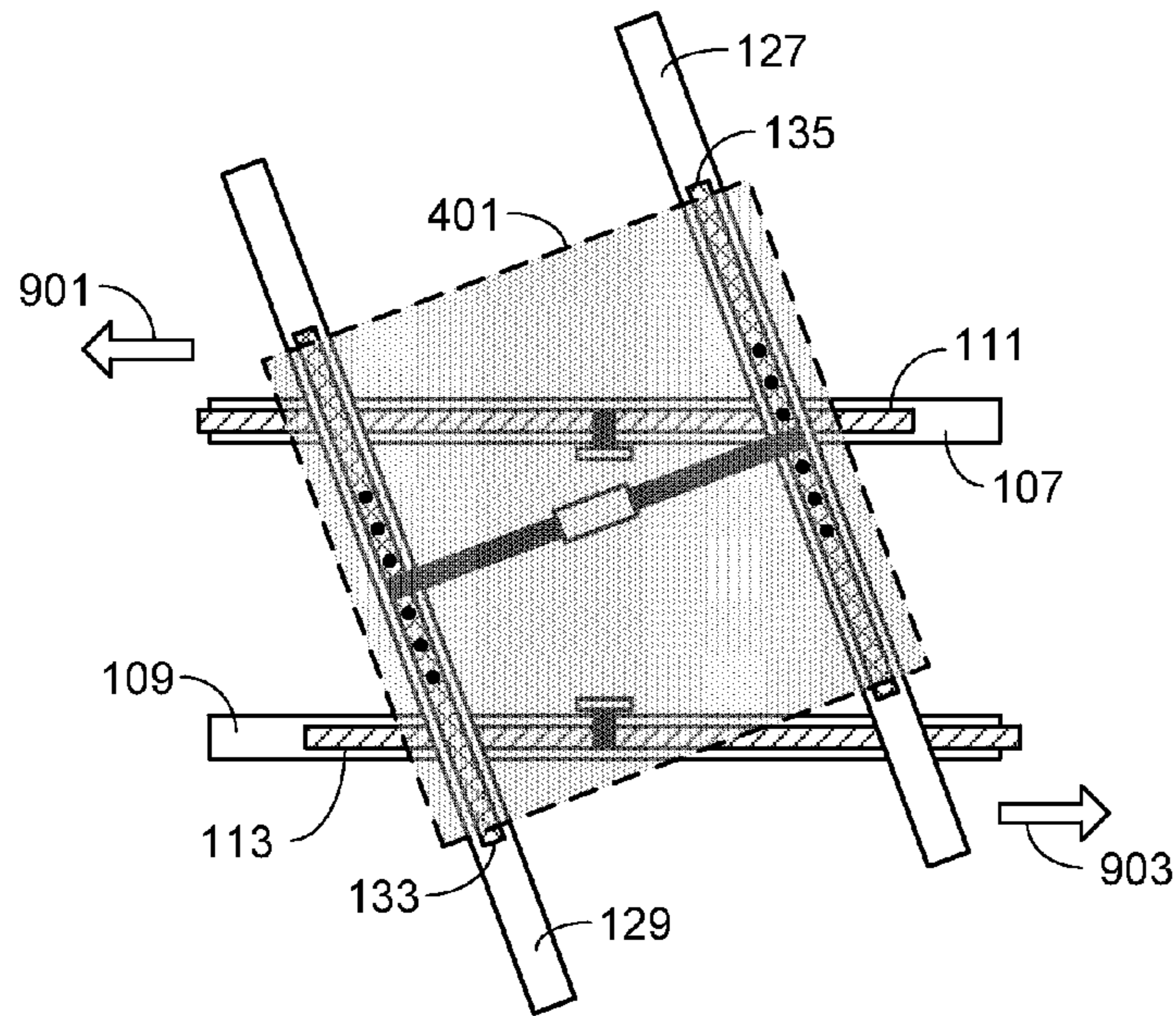

FIG. 9

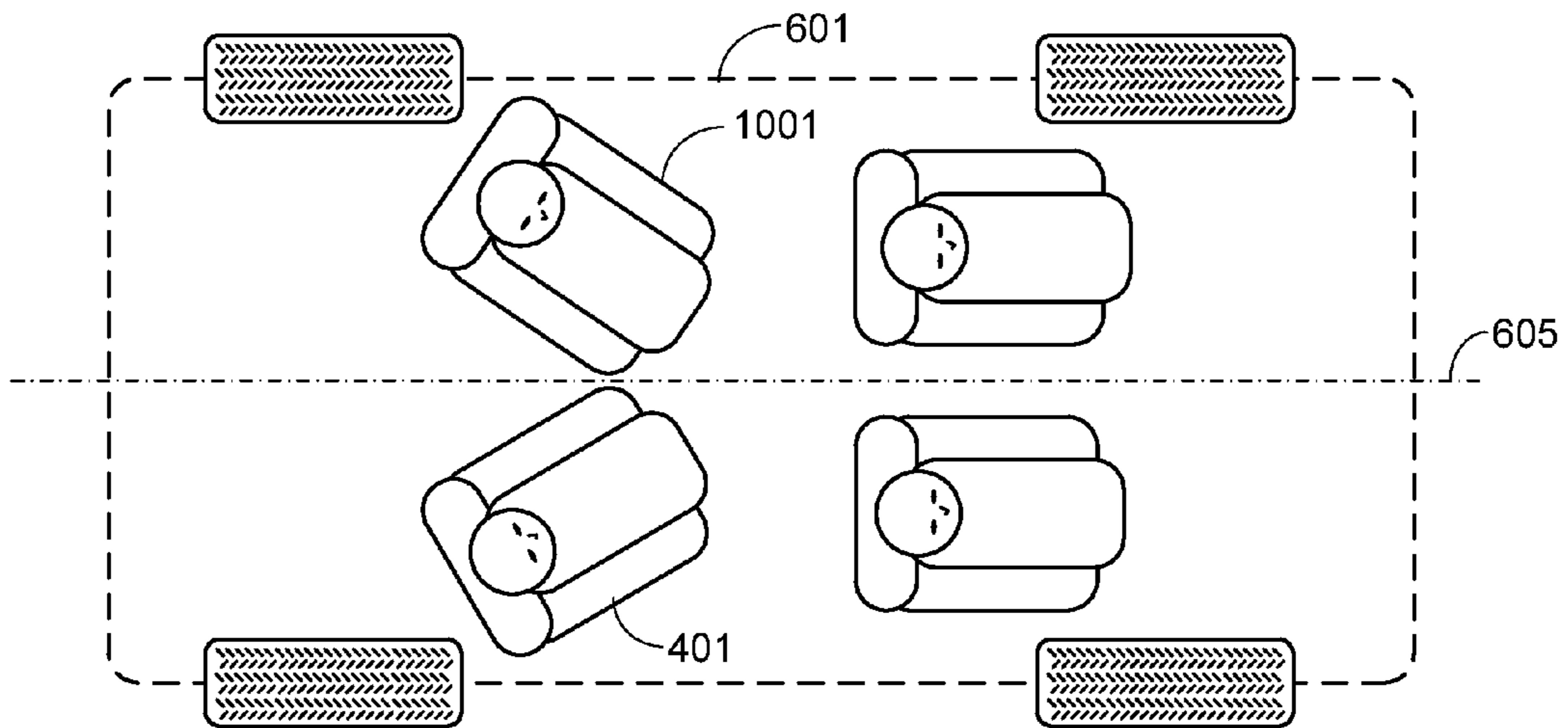
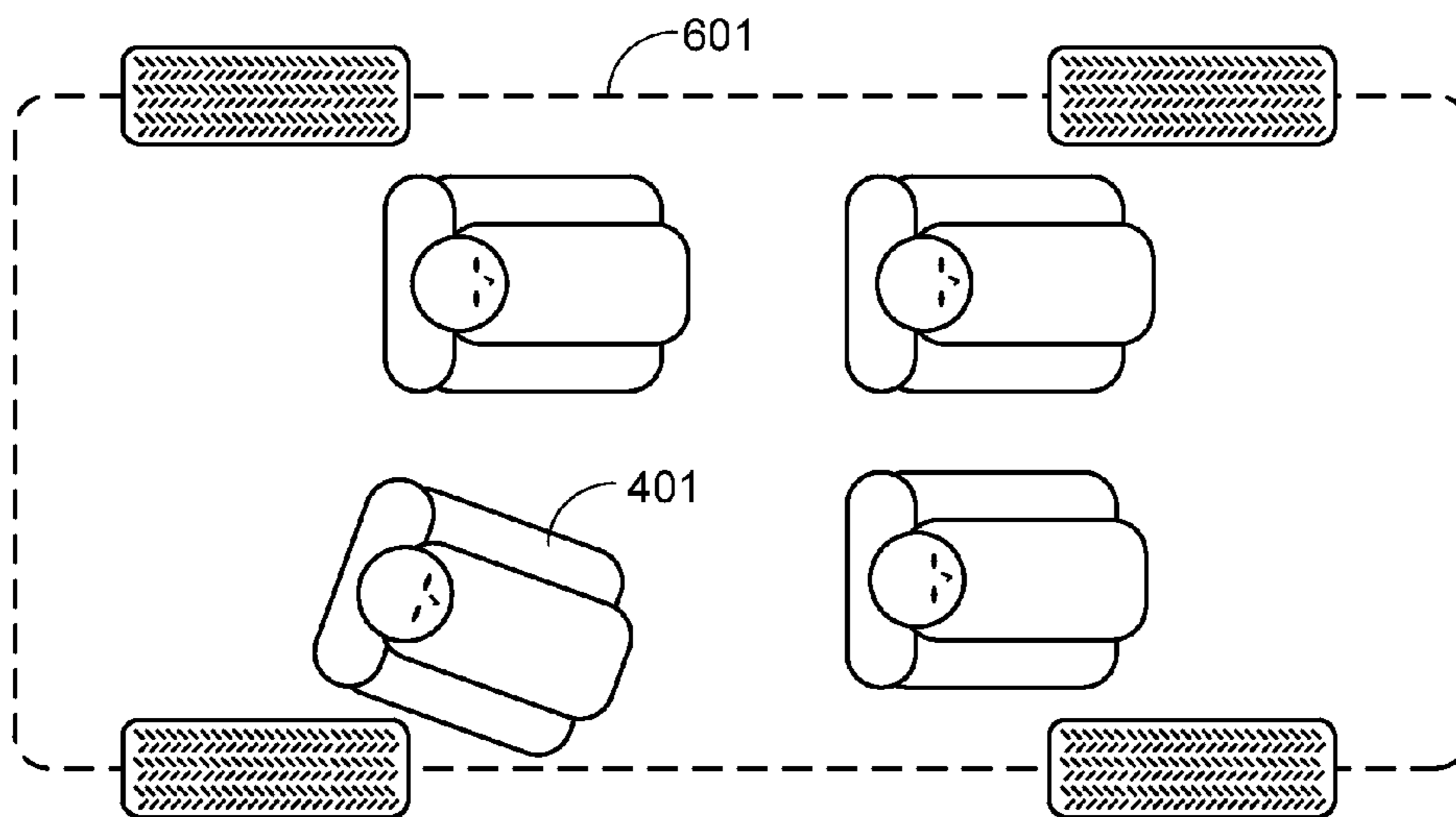
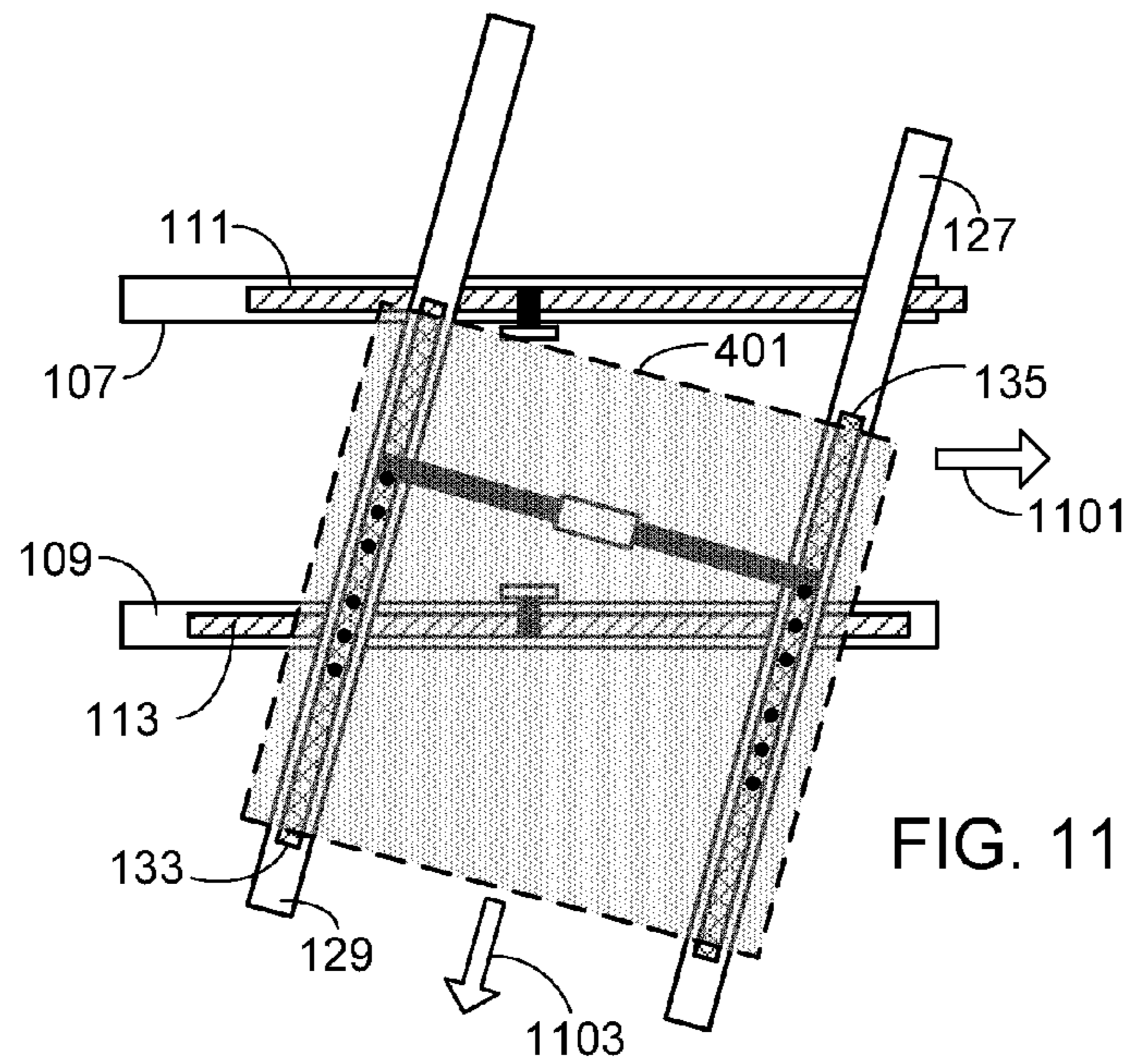

FIG. 10



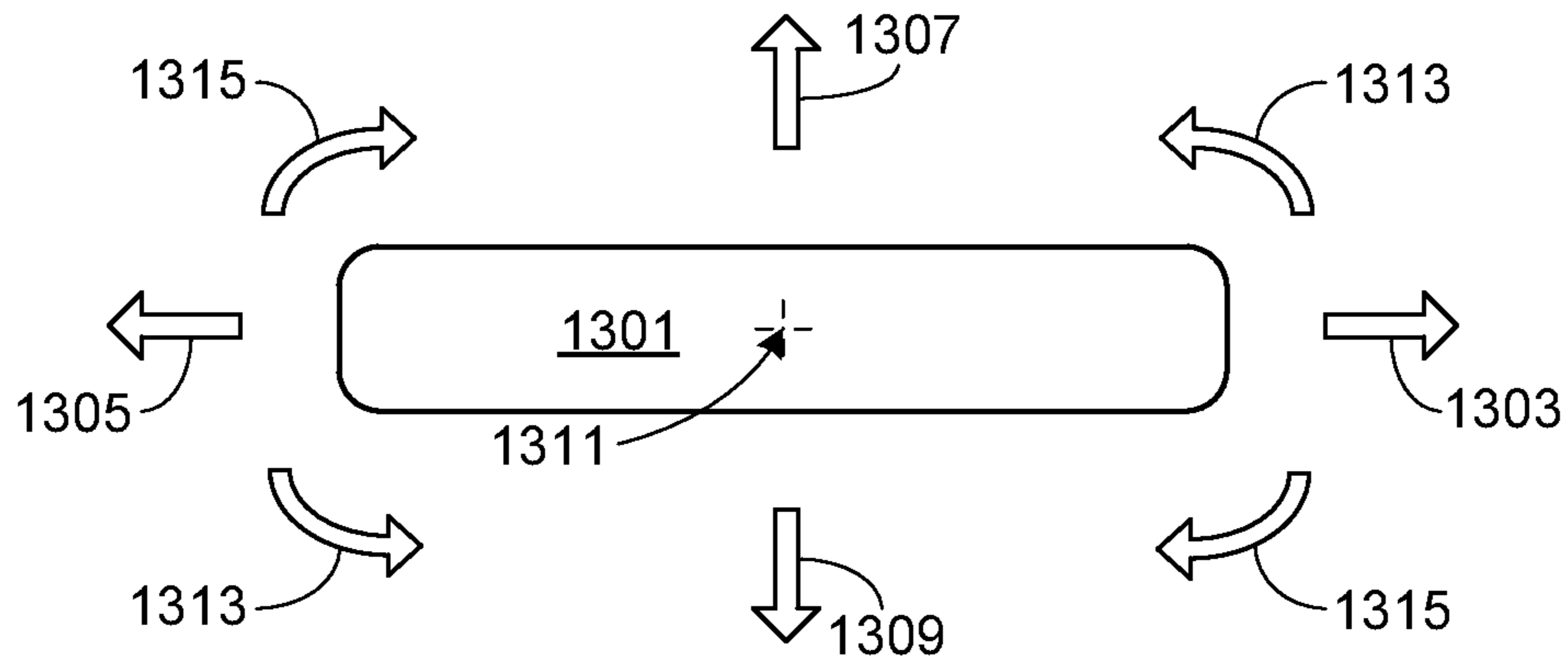

FIG. 13

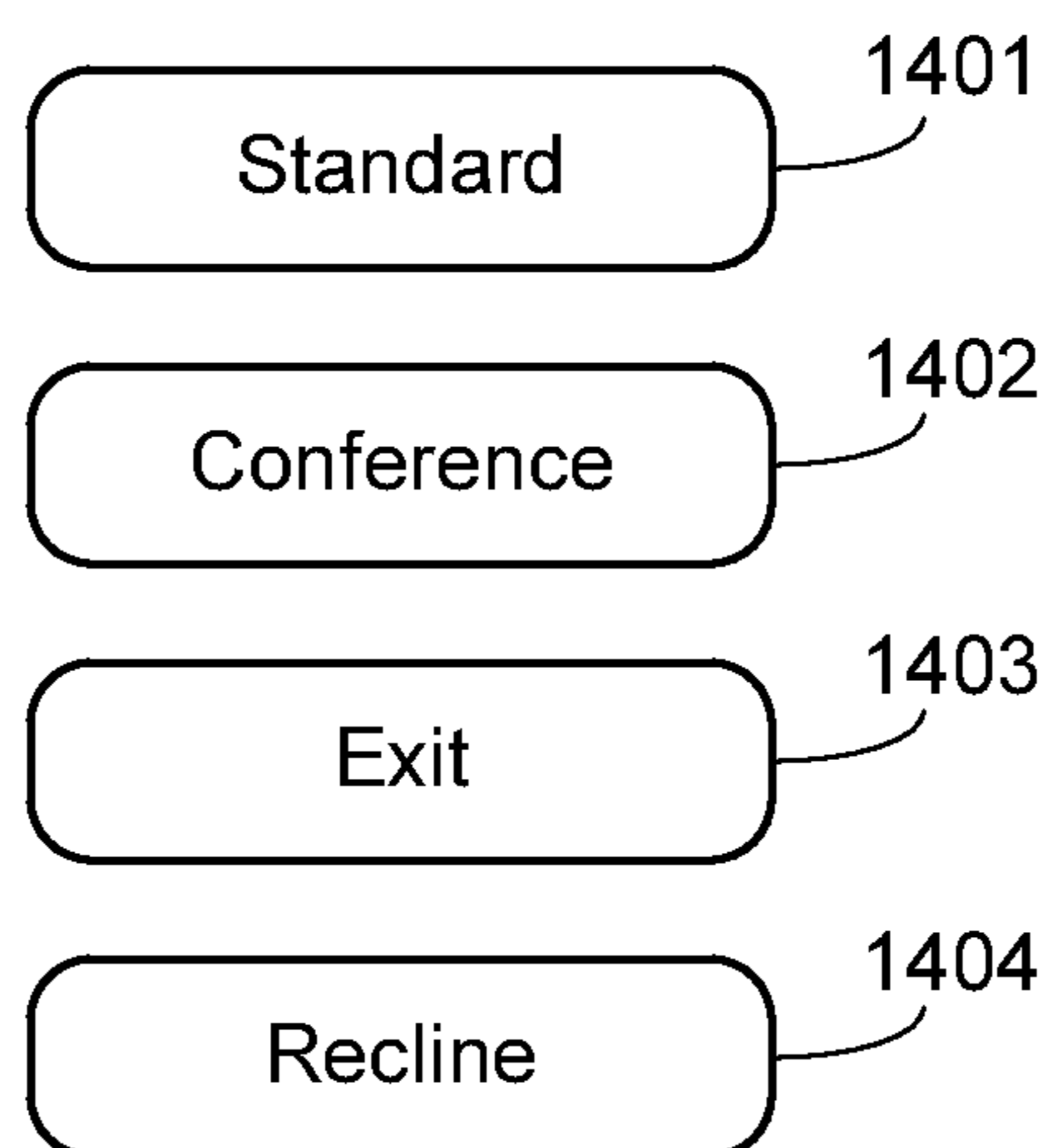

FIG. 14

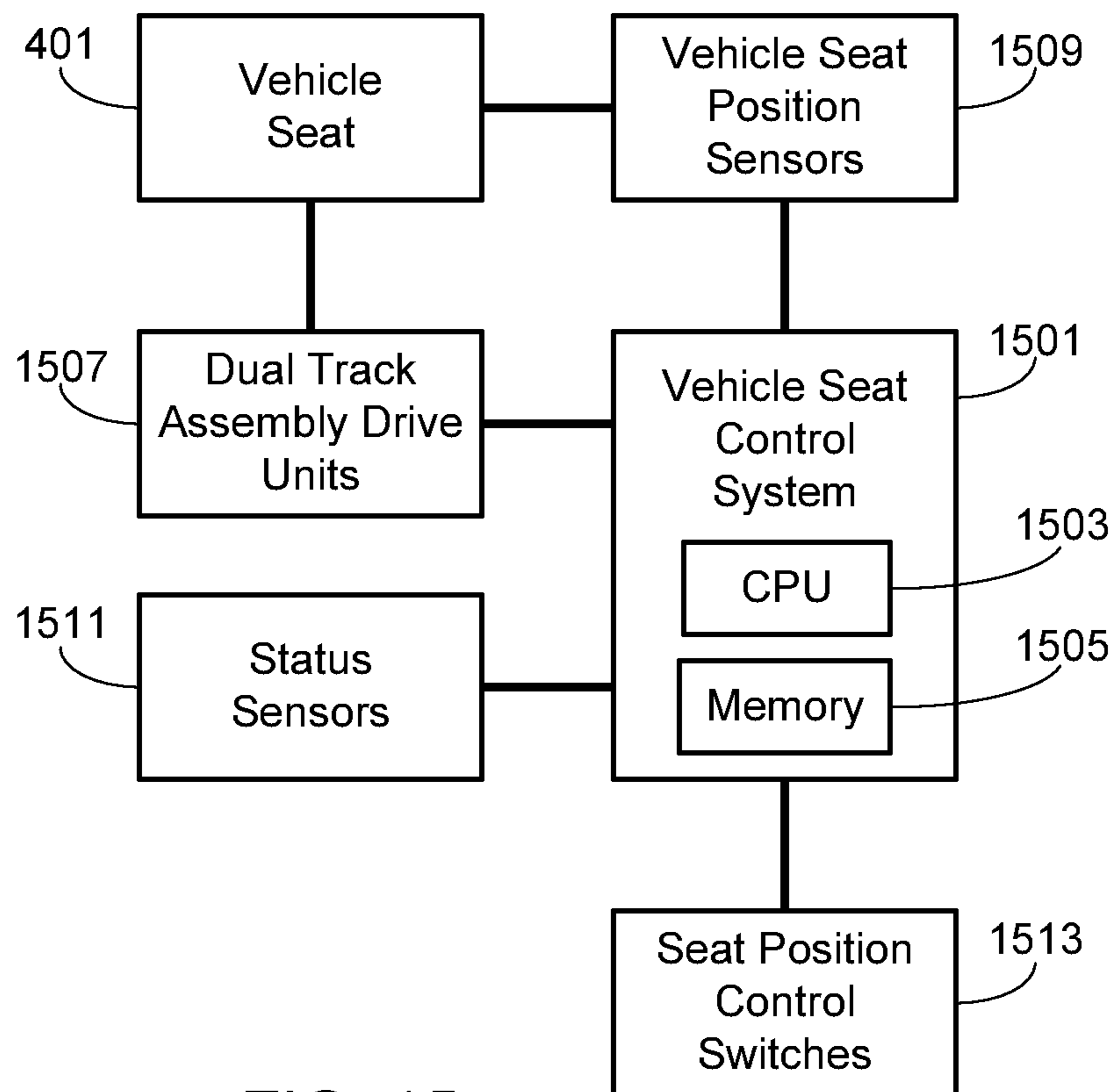

FIG. 15

1

MULTI-POSITION VEHICLE SEAT

FIELD OF THE INVENTION

The present invention relates generally to a vehicle and, more particularly, to a system and method that allows a car seat to be configured in a variety of positions.

BACKGROUND OF THE INVENTION

Luxury vehicles offer a number of user amenities that provide both the driver and the passengers with a more enriching experience; one which attempts to accommodate the particular wants and needs of each of the car's occupants. For example, many cars allow the driver to select between multiple driving modes by simply rotating a knob or pushing a button, where each driving mode alters a variety of vehicle characteristics ranging from throttle response to suspension set-up. Commonly used driving modes include normal, economy and sport. Another feature that has become commonplace among luxury vehicles is the ability to preset and memorize the various aspects of the driver's seat, e.g., seat position, seat height, seatback incline, lumbar support, seat cushion angle and seat cushion length. Once preset, recorded in memory and assigned to a particular user, the preset settings may be re-obtained by simply pushing a button within the car or activating the car with a user assigned key fob. Outside mirrors and steering wheel position may also be linked to the same memory, thus allowing the vehicle to automatically adjust the driver's seat, steering wheel and mirror placement once a particular driver is identified.

In addition to providing the driver with a more engaging experience that may be customized to enhance performance, ergonomics, comfort, safety and/or convenience, many luxury vehicles also try to cater to the desires of the vehicle's passengers. For example, luxury vehicles often provide rear seat passengers with separate rear compartment heating and ventilation controls that may include individual seat heaters as well as individually controllable fans and vents. Additionally, such vehicles often provide electric window shades and a rear compartment audio-video system that may include a video game player, a DVD player, an MP3 player, wired/wireless headphone connections, etc. Unfortunately, the rear seats in most luxury vehicles are only distinguishable from a those in a conventional car based on material selection and seat padding. Accordingly, while the features incorporated into many luxury vehicles provide the passengers a relaxed and enjoyable setting, further improvements in seating comfort and versatility are desired so that the occupants seated in the rear portion of the passenger cabin can more easily converse and enjoy the ride. Accordingly, the present invention provides a multipurpose and comfortable seating system for the rear passenger compartment.

SUMMARY OF THE INVENTION

The present invention provides a vehicle seat positioning system, comprising (i) a first pair of track assemblies mounted within a vehicle, where the first pair of track assemblies includes a first pair of fixed track members and a first pair of rails, where the first pair of rails are configured to slide within the first pair of fixed track members, and where the first pair of fixed track members are attached to a vehicle structure; (ii) a second pair of track assemblies, where the second pair of track assemblies includes a second pair of fixed track members and a second pair of rails, where

2

the second pair of rails are configured to slide within the second pair of fixed track members, and where the second pair of fixed track members are coupled to the first pair of rails; (iii) a vehicle seat mounted to the second pair of rails; (iv) a drive system coupled to the first and second pairs of track assemblies, where the drive system is configured to move the vehicle seat in a forward direction and a backward direction within a first range of motion via one of the first and second pairs of track assemblies, where the drive system is configured to move the vehicle seat in a lateral-left direction and a lateral-right direction within a second range of motion via one of the first and second pairs of track assemblies, and where the drive system is configured to move the vehicle seat in a clockwise rotational direction and a counter-clockwise rotational direction within a third range of motion via the first and second pairs of track assemblies; (v) a seat position selection system; and (vi) a control system coupled to the drive system and to the seat position selection system, where the control system adjusts a position corresponding to the vehicle seat using the drive system in response to an input signal from the seat position selection system.

In one aspect, the drive system may be configured to move the vehicle seat in the forward and backward directions within the first range of motion via the second pair of track assemblies, and configured to move the vehicle seat in the lateral-left and lateral-right directions within the second range of motion via the first pair of track assemblies.

In another aspect, the drive system may include a first drive unit (e.g., an electro-mechanical motor) coupled to the first track assembly of the first pair of track assemblies, a second drive unit (e.g., an electro-mechanical motor) coupled to the second track assembly of the first pair of track assemblies, and a third drive unit (e.g., an electro-mechanical motor) coupled to the second pair of track assemblies. The drive system may further include a first rack and pinion actuator coupling the first drive unit to the first track assembly of the first pair of track assemblies, a second rack and pinion actuator coupling the second drive unit to the second track assembly of the first pair of track assemblies, and a third rack and pinion actuator coupling the third drive unit to the second pair of track assemblies.

In another aspect, the first rail of the first pair of track assemblies may be coupled to the first fixed track member of the second pair of track assemblies via a first pin; and the first rail of the first pair of track assemblies may be coupled to the second fixed track member of the second pair of track assemblies via a second pin; and the second rail of the first pair of track assemblies may be coupled to the first fixed track member of the second pair of track assemblies via a third pin; and the first rail of the first pair of track assemblies may be coupled to the second fixed track member of the second pair of track assemblies via a fourth second pin. Additionally, the first fixed track member of the second pair of track assemblies may include a first mounting slot and a first mounting aperture, and the second fixed track member of the second pair of track assemblies may include a second mounting slot. In this configuration, the first pin passes through the first mounting slot of the first fixed track member of the second pair of track assemblies, the third pin passes through the first mounting aperture of the first fixed track member of the second pair of track assemblies, and the second and fourth pins pass through the second mounting slot of the second fixed track member of the second pair of track assemblies. The second mounting slot of the second fixed track member of the second pair of track assemblies may be divided into a first slot and a second slot, where the

3

second pin passes through the first slot of the second mounting slot of the second fixed track member of the second pair of track assemblies, and where the fourth pin passes through the second slot of the second mounting slot of the second fixed track member of the second pair of track assemblies.

In another aspect, a floor panel may be interposed between the first pair of fixed track members and the vehicle structure. The vehicle structure may be comprised of at least one vehicle frame member or of a battery pack enclosure.

In another aspect, the vehicle seat may be welded or bolted to the second pair of rails.

In another aspect, the seat position selection system may be comprised of (i) a plurality of switches with each switch corresponding to a preset vehicle seat position; (ii) at least one multi-positional switch configured to move in a plurality of directions with each direction corresponding to a preset direction of motion for the vehicle seat; and/or (iii) a plurality of seat positioning switches in which each switch corresponds to a preset direction of motion for the vehicle seat.

In another aspect, the system may further include at least one vehicle status sensor coupled to the control system and configured to monitor at least one vehicle subsystem. The control system may then be configured to adjust the vehicle seat's position in response to a specific condition corresponding to the monitored vehicle subsystem, where exemplary specific conditions include the vehicle being activated (e.g., powered on), deactivated (e.g., powered down), placed into park, placed into drive, etc. The vehicle status sensor may monitor vehicle speed and the specific condition may correspond to the current vehicle speed exceeding a preset vehicle speed; alternately, the vehicle status sensor may monitor at least one vehicle door lock and the specific condition may correspond to the door lock shifting from a door locked condition to a door unlocked condition; alternately, the vehicle status sensor may monitor at least one vehicle door lock and the specific condition may correspond to the door lock shifting from a door unlocked condition to a door locked condition.

A further understanding of the nature and advantages of the present invention may be realized by reference to the remaining portions of the specification and the drawings.

BRIEF DESCRIPTION OF THE DRAWINGS

It should be understood that the accompanying figures are only meant to illustrate, not limit, the scope of the invention and should not be considered to be to scale. Additionally, the same reference label on different figures should be understood to refer to the same component or a component of similar functionality.

FIG. 1 provides a top view of a dual track system that is used with at least one embodiment of the invention;

FIG. 2 illustrates the coupling between the fore/aft and lateral track assemblies of the dual track system shown in FIG. 1;

FIG. 3 provides the same view of the dual track system as shown in FIG. 1, modified to exclude the upper rail members so that the upper track assembly mounting pins are visible;

FIG. 4 provides the same view of the dual track system as shown in FIG. 1, modified to illustrate the mounting of the seat to the upper set of rail members;

FIG. 5 provides the same view of the dual track system as shown in FIG. 1, modified to illustrate lateral movement of a vehicle seat;

4

FIG. 6 provides a top view of a vehicle's passenger cabin in which the right rear passenger seat has been moved laterally toward the vehicle's centerline;

FIG. 7 provides the same view of the dual track system as shown in FIG. 1, modified to illustrate forward movement of a vehicle seat;

FIG. 8 provides a top view of a vehicle's passenger cabin in which the right rear passenger seat has been moved forward;

FIG. 9 provides the same view of the dual track system as shown in FIG. 1, modified to illustrate rotational movement of a vehicle seat;

FIG. 10 provides a top view of a vehicle's passenger cabin in which both rear passenger seats have been rotated inwards towards the vehicle's centerline;

FIG. 11 provides the same view of the dual track system as shown in FIG. 1, modified to illustrate a vehicle chair that has been rotated outwardly and moved laterally right and backwards;

FIG. 12 provides a top view of a vehicle's passenger cabin in which the right rear passenger seat has been rotated outwardly and moved laterally right and backwards;

FIG. 13 illustrates an exemplary multi-positional switch that may be used to control all motions of vehicle seat coupled to the seat positioning system of the invention;

FIG. 14 illustrates a plurality of switches, each of which corresponds to a pre-programmed seat position; and

FIG. 15 provides a system level diagram of an exemplary control system for use with the dual track seat positioning system of the invention

DESCRIPTION OF THE SPECIFIC EMBODIMENTS

As used herein, the singular forms "a", "an" and "the" are intended to include the plural forms as well, unless the context clearly indicates otherwise. The terms "comprises", "comprising", "includes", and/or "including", as used herein, specify the presence of stated features, process steps, operations, elements, and/or components, but do not preclude the presence or addition of one or more other features, process steps, operations, elements, components, and/or groups thereof. As used herein, the term "and/or" and the symbol "/" are meant to include any and all combinations of one or more of the associated listed items. Additionally, while the terms first, second, etc. may be used herein to describe various steps, calculations, or components, these steps, calculations, or components should not be limited by these terms, rather these terms are only used to distinguish one step, calculation, or component from another. For example, a first calculation could be termed a second calculation, and, similarly, a first step could be termed a second step, and, similarly, a first component could be termed a second component, without departing from the scope of this disclosure.

As described in detail below, the present invention provides a seat mounting system that allows a vehicle passenger seat, preferably a rear passenger seat mounted within the rear portion of the passenger cabin, to move laterally (i.e., side-to-side), fore-aft (i.e., forwards-backwards), and rotationally. As a result, an occupant of the passenger seat can optimize their seat position for the task at hand, e.g., relaxing, obtaining additional leg and/or shoulder room, rotating inwards during a conversation with others in the car, rotating outwards to aid vehicle egress, etc. In the preferred embodiment, seat movement is accomplished via automated track assemblies. It should be understood, however, that the

5

seat mounting system of the invention may also be used in a manual configuration, i.e., with manually operated track assemblies.

FIG. 1 provides a top view of a dual track system that is used with at least one embodiment of the invention. The first pair of track assemblies, which includes assemblies 101 and 103, is mounted to a vehicle structure such as the vehicle's floor 105. In a typical configuration, means such as a plurality of bolts are used to attach the track assemblies 101/103 to floor 105, and preferably to floor 105 as well as an underlying and/or integral vehicle structure (e.g., a vehicle frame member). In at least one embodiment the bolts used to mount the first set of track assemblies pass through floor panel 105 and are bolted to an underlying battery pack enclosure. It should be understood that the seat mounting system may be attached to any of a variety of vehicle structures as long as the selected structure is sufficiently strong to insure that seat movement during a car collision remains within acceptable limits.

Each track assembly 101 and 103 includes a fixed track member 107 and 109, respectively, and a rail member 111 and 113, respectively, where the rail members are designed to slide within the corresponding fixed track member. When mounted within the car, rails 111 and 113 move laterally as indicated in the figure by reference 115. As noted previously, although the system can be configured to be manually operable, preferably it is automated. Accordingly, in the illustrated embodiment track assembly 101 is coupled to drive unit 117 and track assembly 103 is coupled to drive unit 119. Preferably drive units 117 and 119 are electro-mechanical motors, although it will be appreciated that other types of drive units may be used (e.g., hydraulic drives). In the illustrated embodiment, drive shaft 121 of drive unit 117 is coupled to track assembly 101 using a rack and pinion actuator. Similarly, drive shaft 123 of drive unit 119 is coupled to track assembly 103 using a rack and pinion actuator.

A second pair of track assemblies, comprised of assemblies 125 and 127, is mounted to the first pair of track assemblies. As with the first pair of assemblies, each track assembly 125 and 127 includes a fixed track member 129 and 131, respectively, and a rail member 133 and 135, respectively, where the rail members are designed to slide within the corresponding fixed track member. When mounted, track assemblies 125 and 127 provide substantially fore-aft movement as indicated in the figure by reference 137. As with the first pair of track assemblies, while manual operation is permissible, preferably automated operation is used. In the preferred embodiment, a single drive unit 139 (e.g., electro-mechanical or hydraulic drive) is used to position rails 133 and 135 relative to the corresponding track members 129 and 131, respectively. In the illustrated embodiment, drive unit 139 includes a first drive shaft 141 coupled to track assembly 129 via a first rack and pinion actuator and a second drive shaft 143 coupled to track assembly 131 via a second rack and pinion actuator. While actuation of both track assemblies 129 and 131 is preferred in order to insure smooth seat movement, in an alternate configuration drive unit 139 is only coupled to one of the track assemblies. As rail members 133 and 135 are rigidly tied together via the seat as described below, in this configuration the non-driven track assembly is free to move and as a result, simply follows the driven track assembly.

The mounting between the upper pair of track assemblies 125/127 and the lower pair of track assemblies 101/103 is illustrated in FIG. 2. This figure provides a cross-sectional view of a portion of the dual track system described above.

6

As shown, an upper track member (e.g., member 131) is pinned to lower rail member (e.g., member 111) via a pin 201. Pin 201 allows an upper track member to rotate relative to a lower rail member. Additionally and as illustrated in FIG. 3, the upper track member may be slotted in order to provide the desired range of motion as described in detail below.

FIG. 3 illustrates the assembly shown in FIG. 1 with upper rails 133 and 135 removed for clarity. As shown, pin 301 only allows upper track member 129 to rotate about rail 113 at the point at which the two are pinned together. In contrast, pin 303 allows upper track member 129 to rotate about rail 111 and to slide within slot 305. Similarly, pin 307 allows upper track member 131 to rotate about rail 113 and to slide within slot 309, and pin 311 allows upper track member 131 to rotate about rail 111 and to slide within slot 313.

The vehicle seat is rigidly attached to upper rails 133 and 135, for example via bolts, welding, brazing or other means. FIG. 4 illustrates the dual track assembly shown in the previous figures with a vehicle seat 401 mounted to upper rails 133 and 135 via a plurality of bolts 403. It should be understood that other techniques such as welding or brazing may be used to attach vehicle seat 401 to rails 133/135. Note that in FIG. 4 only the outer envelope of vehicle seat 401 is shown (in phantom), thus allowing mounting bolts 403 to be visible as well as the underlying dual track system.

FIGS. 5-12 illustrate the dual track system of the invention with the seat shown in a variety of positions. In FIG. 5, seat 401 has been moved laterally to the left by uniformly adjusting rails 111 and 113 to the left, as represented by directional arrow 501. This repositioning of seat 401 is illustrated in FIG. 6 which shows a top view of the passenger cabin of a vehicle 601. In vehicle 601, seat 401 is the right back seat. As shown in FIG. 6, moving seat 401 laterally to the left by adjusting rails 111 and 113 in direction 603 moves the seat towards the vehicle's centerline 605. In the preferred embodiment, seat 401 may also be moved laterally to the right, towards the right side of the car, by adjusting rails 111 and 113 to the right (i.e., in a direction that is the opposite of direction 501 in FIG. 5).

In FIG. 7, seat 401 has been moved forward in a direction 701 by uniformly moving rails 133 and 135 forward. As illustrated in the corresponding seat arrangement shown in FIG. 8, as a result of moving rails 133 and 135 forward in a direction 801, seat 401 has been moved closer to front passenger seat 803. Moving seat 401 forward, as shown, provides additional room behind the seat that may be used for storage or to provide additional space for reclining the back of seat 401. Preferably seat 401 may also be moved backwards by moving rails 133 and 135 to the rear, i.e., in a direction that is the opposite of direction 701 in FIG. 7, thus providing additional leg room in front of the seat.

In addition to lateral and fore-aft seat movement, the dual tracking system in combination with the separate drive units coupled to rails 111 and 113 provide another degree of motion for chair 401, specifically seat rotation. Vehicle seat rotation is achieved by moving rails 111 and 113 non-uniformly, i.e., by moving rails 111 and 113 in opposite directions from one another, or by moving one of these rails while holding the remaining rail stationary, or by moving both rails 111 and 113 in the same direction but by different amounts. In the illustrated example shown in FIGS. 9 and 10, rail 111 is moved laterally left in a direction 901 and rail 113 is moved laterally right in a direction 903. As a result, vehicle seat 401 is rotated towards vehicle centerline 605 as illustrated in FIG. 10. To better illustrate some of the benefits of the present invention, in FIG. 10 the second rear vehicle

seat, seat **1001**, has also been rotated towards vehicle centerline **605**. As a result of this seating arrangement, occupants seated in the rear portion of the passenger compartment can more easily carry on a face-to-face conversation.

It should be understood that rotation of a vehicle seat does not prevent the dual tracking system of the present invention from providing fore-aft and/or lateral motion of the vehicle seat. For example, in FIG. **11** vehicle seat **401** is rotated outwardly, laterally right, and backwards, thus allowing easy egress from vehicle **601**. In this example both rails **111** and **113** are moved laterally right in a direction **1101**, although rail **111** has been moved further right. As a result, seat **401** is moved right as well as rotated outwards towards the side of the car. Additionally, rails **133** and **135** are moved backwards in a direction **1103**, thus causing backwards seat motion. This seat arrangement is illustrated in FIG. **12**.

As described above, preferably the dual track system of the invention is powered, for example by a set of electro-mechanical or hydraulic drive units, thus simplifying seat positioning. In one embodiment, one or more seat positioning switches are mounted on the side of the seat, within easy reach of the seat's occupant. In an alternate embodiment, the seat positioning switch or switches are located within the passenger cabin, for example on the door next to the seat that is controlled by the switches. FIG. **13** illustrates an exemplary multi-positional switch **1301** that can be used to control all motions of vehicle seat **401**, and that can be mounted on the side of the chair or elsewhere within the passenger cabin. Moving switch **1301** in a direction **1303** causes forward motion of vehicle seat **401**; moving switch **1301** in a direction **1305** causes rearward motion of vehicle seat **401**; moving switch **1301** in a direction **1307** causes vehicle seat **401** to move laterally to the left; moving switch **1301** in a direction **1309** causes vehicle seat **401** to move laterally to the right; rotating switch **1301** clockwise about axis **1311** in a direction **1313** causes vehicle seat **401** to rotate clockwise; and rotating switch **1301** counter-clockwise about axis **1311** in a direction **1315** causes vehicle seat **401** to rotate counter-clockwise. It should be understood that switch **1301** only illustrates one possible configuration for a seat positioning switch, and that the inventor envisions other configurations such as the use of multiple switches, touch-sensitive switches displayed on a touch-panel adjacent to vehicle seat **401**, etc.

In at least one embodiment a seat control system, coupled to the seat drive units (e.g., drive units **117**, **119** and **139**), is pre-programmed with multiple seat positions. Preferably a plurality of switches, e.g., mechanical switches or touch-sensitive switches on a display unit, correspond to each of these pre-programmed seat positions, thereby simplifying selection of a particular position. FIG. **14** illustrates a set of seat position selection switches **1401-1404** that correspond to an exemplary set of pre-programmed seat positions. In the illustrated set of position selection switches, switch **1401** corresponds to a "Standard" position. The standard position may be one in which leg room is optimized and the seat is centered between the adjacent door and the vehicle's centerline. Switch **1402** corresponds to a "Conference" position, i.e., one in which the affected seat is rotated inwardly towards the center of the car, thus facilitating face-to-face discussions. Switch **1403** corresponds to an "Exit" position, i.e., one in which the affected seat is moved backwards and rotated outwardly, thereby providing easy egress from the vehicle. Switch **1404** corresponds to a "Recline" position. In this position the vehicle seat is moved in order to facilitate seat recline, for example by moving the chair slightly

forward. Assuming a power recline feature, this switch may also automatically recline the seat. Preferably the seat position selection switches are mounted in a convenient location for easy access by one or both of the occupants of the rear portion of the passenger compartment; alternately, the seat position selection switches, or a secondary set of seat position selection switches, may be accessible to the driver of the car. In the preferred embodiment, the seat position selection switches only affect a single seat. In an alternate embodiment, one or more of the seat position selection switches affect both of the rear vehicle seats. For example, pressing or otherwise activating conference switch **1402** may cause both rear vehicle seats to rotate inwardly towards the center of the car, thus creating more of a conference room setting. Similarly, the exit switch **1403** may move both rear seats to the exit position.

In at least one embodiment of the invention, at least some of the control of the dual track seat positioning system is fully automated. For example, the seat control system may be programmed to optimize seat(s) position for vehicle entrance/egress when the controller determines that someone is likely to enter or exit the vehicle. Some of the conditions that may be monitored in order to make such a determination include (i) monitoring when the internal door handle is touched; (ii) monitoring when the internal door handle is in use, i.e., activated; (iii) monitoring when the external door handle is touched; (iv) monitoring when the external door handle is in use, i.e., activated; (v) monitoring when the car doors are unlocked; (vi) monitoring when the car is placed in park; (vii) monitoring when the parking brake is activated and/or deactivated; and/or (viii) monitoring when the car is turned on or turned off. A fully automated seat control system may also be configured to return the seat(s) to the "standard" position under certain conditions, such as when the vehicle speed exceeds a preset speed.

FIG. **15** is a high-level view of some of the primary vehicle systems which may be used to control the dual track seat positioning system of the invention. The system includes a vehicle seat control system **1501**, also referred to herein as a seat controller. Seat controller **1501**, which includes a control processor, may be a dedicated control system or integrated into another vehicle control system, for example a vehicle management system. Controller **1501** includes a central processing unit (CPU) **1503** and a memory **1505**, with memory **1505** being comprised of EPROM, EEPROM, flash memory, RAM, solid state drive, hard disk drive, or any other type of memory or combination of memory types. Memory **1505** may be used to store pre-set seat positions such as a preferred conference position, a vehicle entrance/egress position, etc.

Coupled to vehicle seat control system **1501** is the seat positioning system **1507**, where the positioning system includes the drive units coupled to the dual track assemblies (e.g., drive units **117**, **119** and **139**). Vehicle seat **401** is coupled to the seat positioning system **1507** and to seat position sensors **1509**. Sensors **1509** may directly monitor seat position. Alternately, sensors **1509** may simply represent the feedback provided by the drive units which, once calibrated, can be used to accurately determine seat position. Preferably coupled to vehicle seat controller **1501** are a variety of sensors **1511** that may be used to monitor various vehicle subsystems in order to determine specific vehicle conditions such as vehicle speed, whether or not the vehicle is turned on (i.e., activated) or turned off (i.e., deactivated), whether the vehicle is in park and/or gear (e.g., drive), whether or not the doors are locked, whether an internal door handle is being touched or activated, whether an external

door handle is being touched or activated, etc. As described above, control system **1501** may be configured to automatically position vehicle seat **401** using data acquired through sensors **1511**. Seat position control switches **1513** are also coupled to controller **1501**, where the switches may be configured to simply move the seat in the selected direction as described above relative to FIG. **13**, or may be configured to move the seat to a pre-selected position as described above relative to FIG. **14**.

Systems and methods have been described in general terms as an aid to understanding details of the invention. In some instances, well-known structures, materials, and/or operations have not been specifically shown or described in detail to avoid obscuring aspects of the invention. In other instances, specific details have been given in order to provide a thorough understanding of the invention. One skilled in the relevant art will recognize that the invention may be embodied in other specific forms, for example to adapt to a particular system or apparatus or situation or material or component, without departing from the spirit or essential characteristics thereof. Therefore the disclosures and descriptions herein are intended to be illustrative, but not limiting, of the scope of the invention.

What is claimed is:

1. A vehicle seat positioning system, comprising:

a first pair of track assemblies mounted within a vehicle, wherein said first pair of track assemblies is comprised of a first pair of fixed track members and a first pair of rails, wherein said first pair of rails are configured to slide within said first pair of fixed track members, and wherein said first pair of fixed track members are attached to a vehicle structure;

a second pair of track assemblies, wherein said second pair of track assemblies is comprised of a second pair of fixed track members and a second pair of rails, wherein said second pair of rails are configured to slide within said second pair of fixed track members, and wherein said second pair of fixed track members are coupled to said first pair of rails, wherein a first rail of said first pair of track assemblies is coupled to a first fixed track member of said second pair of track assemblies via a first pin, wherein said first rail of said first pair of track assemblies is coupled to a second fixed track member of said second pair of track assemblies via a second pin, wherein a second rail of said first pair of track assemblies is coupled to said first fixed track member of said second pair of track assemblies via a third pin, and wherein said first rail of said first pair of track assemblies is coupled to said second fixed track member of said second pair of track assemblies via a fourth pin, said first fixed track member of said second pair of track assemblies comprising a first mounting slot and a first mounting aperture, said second fixed track member of said second pair of track assemblies comprising a second mounting slot, wherein said first pin passes through said first mounting slot of said first fixed track member of said second pair of track assemblies and said third pin passes through said first mounting aperture of said first fixed track member of said second pair of track assemblies, and wherein said second and fourth pins pass through said second mounting slot of said second fixed track member of said second pair of track assemblies;

a vehicle seat mounted to said second pair of rails;

a drive system coupled to said first pair of track assemblies and said second pairs of track assemblies, wherein said drive system is configured to move said vehicle

seat in a forward direction and a backward direction within a first range of motion via one of said first and second pairs of track assemblies, wherein said drive system is configured to move said vehicle seat in a lateral-left direction and a lateral-right direction within a second range of motion via one of said first and second pairs of track assemblies, and wherein said drive system is configured to move said vehicle seat in a clockwise rotational direction and a counter-clockwise rotational direction within a third range of motion via said first and second pairs of track assemblies;

a seat position selection system; and

a control system coupled to said drive system and to said seat position selection system, wherein said control system adjusts a position corresponding to said vehicle seat using said drive system in response to an input signal from said seat position selection system.

2. The vehicle seat positioning system of claim **1**, wherein said drive system is configured to move said vehicle seat in said forward direction and said backward direction within said first range of motion via said second pair of track assemblies, and wherein said drive system is configured to move said vehicle seat in said lateral-left direction and said lateral-right direction within said second range of motion via said first pair of track assemblies.

3. The vehicle seat positioning system of claim **1**, said drive system further comprising a first drive unit coupled to a first track assembly of said first pair of track assemblies, a second drive unit coupled to a second track assembly of said first pair of track assemblies, and a third drive unit coupled to said second pair of track assemblies.

4. The vehicle seat positioning system of claim **3**, further comprising a first rack and pinion actuator coupling said first drive unit to said first track assembly of said first pair of track assemblies, a second rack and pinion actuator coupling said second drive unit to said second track assembly of said first pair of track assemblies, and a third rack and pinion actuator coupling said third drive unit to said second pair of track assemblies.

5. The vehicle seat positioning system of claim **3**, wherein said first drive unit is comprised of a first electro-mechanical motor, wherein said second drive unit is comprised of a second electro-mechanical motor, and wherein said third drive unit is comprised of a third electro-mechanical motor.

6. The vehicle seat positioning system of claim **1**, wherein said second mounting slot of said second fixed track member of said second pair of track assemblies is divided into a first slot and a second slot, wherein said second pin passes through said first slot of said second mounting slot of said second fixed track member of said second pair of track assemblies, and wherein said fourth pin passes through said second slot of said second mounting slot of said second fixed track member of said second pair of track assemblies.

7. The vehicle seat positioning system of claim **1**, further comprising a floor panel interposed between said first pair of fixed track members and said vehicle structure.

8. The vehicle seat positioning system of claim **7**, wherein said vehicle structure is comprised of at least one vehicle frame member.

9. The vehicle seat positioning system of claim **7**, wherein said vehicle structure is comprised of a battery pack enclosure.

10. The vehicle seat positioning system of claim **1**, wherein said vehicle seat is welded to said second pair of rails.

11

11. The vehicle seat positioning system of claim **1**, wherein said vehicle seat is bolted to said second pair of rails.

12. The vehicle seat positioning system of claim **1**, said seat position selection system further comprising a plurality of switches, wherein each switch of said plurality of switches corresponds to a preset vehicle seat position.

13. The vehicle seat positioning system of claim **1**, said seat position selection system further comprising at least one multi-positional switch configured to move in a plurality of directions, wherein each of said plurality of directions corresponds to a preset direction of motion for said vehicle seat.

14. The vehicle seat positioning system of claim **1**, said seat position selection system further comprising a plurality of seat positioning switches, wherein each of said plurality of seat positioning switches corresponds to a preset direction of motion for said vehicle seat.

15. A vehicle seat positioning system of claim **1**, further comprising at least one vehicle status sensor, wherein said at least one vehicle status sensor is configured to monitor at least one vehicle subsystem, wherein said control system is coupled to said at least one vehicle status sensor, and wherein said control system is configured to adjust said position corresponding to said vehicle seat using said drive system in response to a specific condition corresponding to said at least one vehicle subsystem.

16. The vehicle seat positioning system of claim **15**, wherein said at least one vehicle status sensor monitors a

12

vehicle speed, and wherein said specific condition corresponds to a current vehicle speed exceeding a preset vehicle speed.

17. The vehicle seat positioning system of claim **15**, wherein said at least one vehicle status sensor monitors at least one vehicle door lock, and wherein said specific condition corresponds to said at least one vehicle door lock shifting from a door locked condition to a door unlocked condition.

18. The vehicle seat positioning system of claim **15**, wherein said at least one vehicle status sensor monitors at least one vehicle door lock, and wherein said specific condition corresponds to said at least one vehicle door lock shifting from a door unlocked condition to a door locked condition.

19. The vehicle seat positioning system of claim **15**, wherein said specific condition corresponds to activation of said vehicle.

20. The vehicle seat positioning system of claim **15**, wherein said specific condition corresponds to deactivation of said vehicle.

21. The vehicle seat positioning system of claim **15**, wherein said specific condition corresponds to said vehicle being placed in park.

22. The vehicle seat positioning system of claim **15**, wherein said specific condition corresponds to said vehicle being placed in drive.

* * * * *