



US009437221B2

(12) **United States Patent**  
**Lee et al.**

(10) **Patent No.:** **US 9,437,221 B2**  
(45) **Date of Patent:** **Sep. 6, 2016**

(54) **METHOD OF MAKING A TRANSDUCER HEAD**

USPC ..... 360/125.01–125.07  
See application file for complete search history.

(71) Applicant: **Seagate Technology LLC**, Cupertino, CA (US)

(56) **References Cited**

(72) Inventors: **Lien Lee**, Saint Paul, MN (US);  
**Yongjun Zhao**, Eden Prairie, MN (US);  
**Lijuan Zou**, Eden Prairie, MN (US);  
**Mark Henry Ostrowski**, Lakeville, MN (US)

U.S. PATENT DOCUMENTS

(73) Assignee: **SEAGATE TECHNOLOGY LLC**, Cupertino, CA (US)

7,996,986 B2	8/2011	Gokemeijer	
8,139,448 B1 *	3/2012	Hirano .....	G11B 5/105 369/112.27
8,307,540 B1 *	11/2012	Tran .....	G11B 5/314 219/209
8,375,564 B1	2/2013	Luo et al.	
8,413,317 B1	4/2013	Wan et al.	
8,451,707 B1	5/2013	Stipe	
8,486,286 B1 *	7/2013	Gao .....	G11B 5/1278 216/22
8,491,801 B1	7/2013	Tanner et al.	
8,526,275 B1 *	9/2013	Yuan .....	G11B 5/314 369/13.14
8,565,049 B1 *	10/2013	Tanner .....	G11B 5/3136 369/13.03
8,588,039 B1 *	11/2013	Shi .....	G11B 5/314 369/13.13
8,619,512 B1	12/2013	Yuan et al.	

(\*) Notice: Subject to any disclaimer, the term of this patent is extended or adjusted under 35 U.S.C. 154(b) by 0 days.

(21) Appl. No.: **14/840,600**

(22) Filed: **Aug. 31, 2015**

(Continued)

(65) **Prior Publication Data**

US 2015/0371669 A1 Dec. 24, 2015

FOREIGN PATENT DOCUMENTS

WO 2012-085849 A2 6/2012

**Related U.S. Application Data**

OTHER PUBLICATIONS

(62) Division of application No. 13/794,133, filed on Mar. 11, 2013, now Pat. No. 9,142,231.

International Search Report and Written Opinion of PCT/US2014/019310, mailed Jun. 18, 2014.

(51) **Int. Cl.**  
**G11B 5/31** (2006.01)  
**G11B 5/60** (2006.01)  
**G11B 5/00** (2006.01)

*Primary Examiner* — Allen T Cao  
(74) *Attorney, Agent, or Firm* — HolzerIPLaw, PC

(52) **U.S. Cl.**  
CPC ..... **G11B 5/314** (2013.01); **G11B 5/3163** (2013.01); **G11B 5/6088** (2013.01); **G11B 2005/0021** (2013.01); **Y10T 29/49048** (2015.01); **Y10T 29/49052** (2015.01)

(57) **ABSTRACT**  
A method of making a transducer head disclosed herein includes depositing a spacer layer on an NFT layer of the transducer head, forming an etch stop layer on a spacer layer of a transducer, depositing a cladding layer on the etch stop layer, and milling the cladding layer at a sloped angle such that the milling stops at the etch stop layer.

(58) **Field of Classification Search**  
CPC ..... G11B 5/11; G11B 5/127; G11B 5/187

**19 Claims, 11 Drawing Sheets**

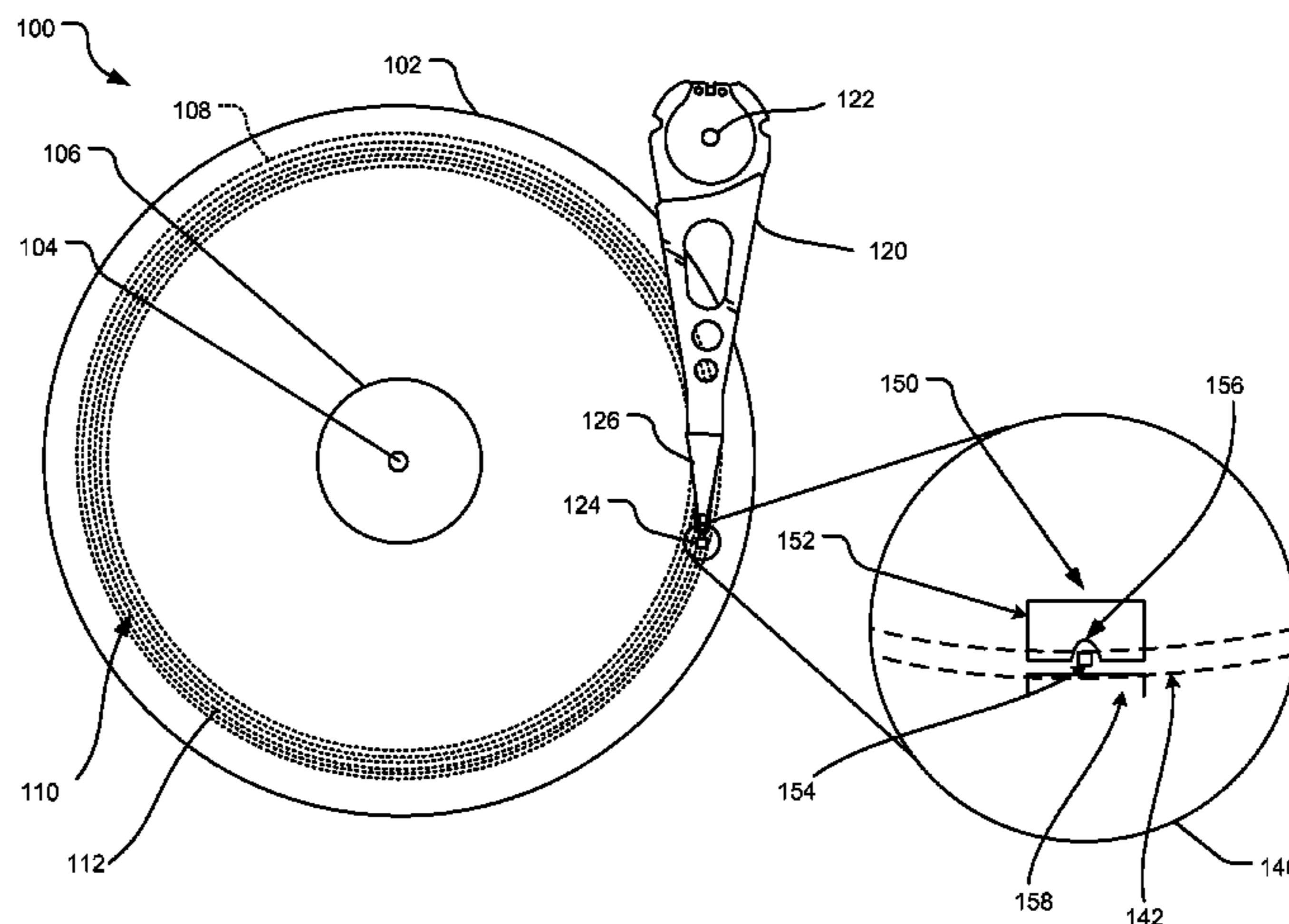

(56)

References Cited

U.S. PATENT DOCUMENTS

8,634,280	B1	1/2014	Wang et al.				
8,670,294	B1 *	3/2014	Shi .....	G11B 5/314			
					360/59		
8,721,902	B1	5/2014	Wang et al.				
8,773,956	B1	7/2014	Wang et al.				
8,790,527	B1 *	7/2014	Luo .....	B29D 11/00663			
					216/24		
8,834,728	B1	9/2014	Hu et al.				
8,873,353	B1	10/2014	Riddering				
9,019,803	B1 *	4/2015	Jin .....	G11B 13/08			
					369/13.33		
9,099,112	B1 *	8/2015	Balamane .....	G11B 5/314			
9,183,856	B1 *	11/2015	Balamane .....	G11B 5/39			
9,202,493	B1 *	12/2015	Wan .....	G11B 5/6088			
2004/0219729	A1 *	11/2004	Kang .....	G11C 7/00			
					438/200		
2005/0000935	A1	1/2005	Snyder et al.				
2010/0214685	A1 *	8/2010	Seigler .....	G11B 5/02			
					360/59		
2010/0321815	A1	12/2010	Zhou et al.				
2011/0286610	A1	11/2011	Ronald				
2011/0294398	A1	12/2011	Hu et al.				
2012/0043586	A1 *	2/2012	Nishimori .....	H01L 29/0657			
					257/194		
2012/0298621	A1	11/2012	Gao				
2013/0064051	A1 *	3/2013	Peng .....	G11B 5/3133			
					369/13.33		
2013/0107680	A1 *	5/2013	Contreras .....	G11B 13/04			
					369/13.32		
2014/0029890	A1 *	1/2014	Sun .....	G02B 6/422			
					385/14		
2014/0307534	A1 *	10/2014	Zhou .....	G11B 13/08			
					369/13.33		
2014/0342559	A1 *	11/2014	Wang .....	H01L 21/30625			
					438/692		
2014/0355399	A1 *	12/2014	Huang .....	G11B 5/3133			
					369/13.17		
2015/0072593	A1 *	3/2015	Zhao .....	B24B 49/10			
					451/1		
2015/0079775	A1 *	3/2015	Wu .....	H01L 21/28158			
					438/587		
2015/0318005	A1 *	11/2015	Kim .....	G11B 5/4866			
					369/13.32		
2015/0340052	A1 *	11/2015	Sankar .....	G11B 5/6088			
					369/13.33		

\* cited by examiner

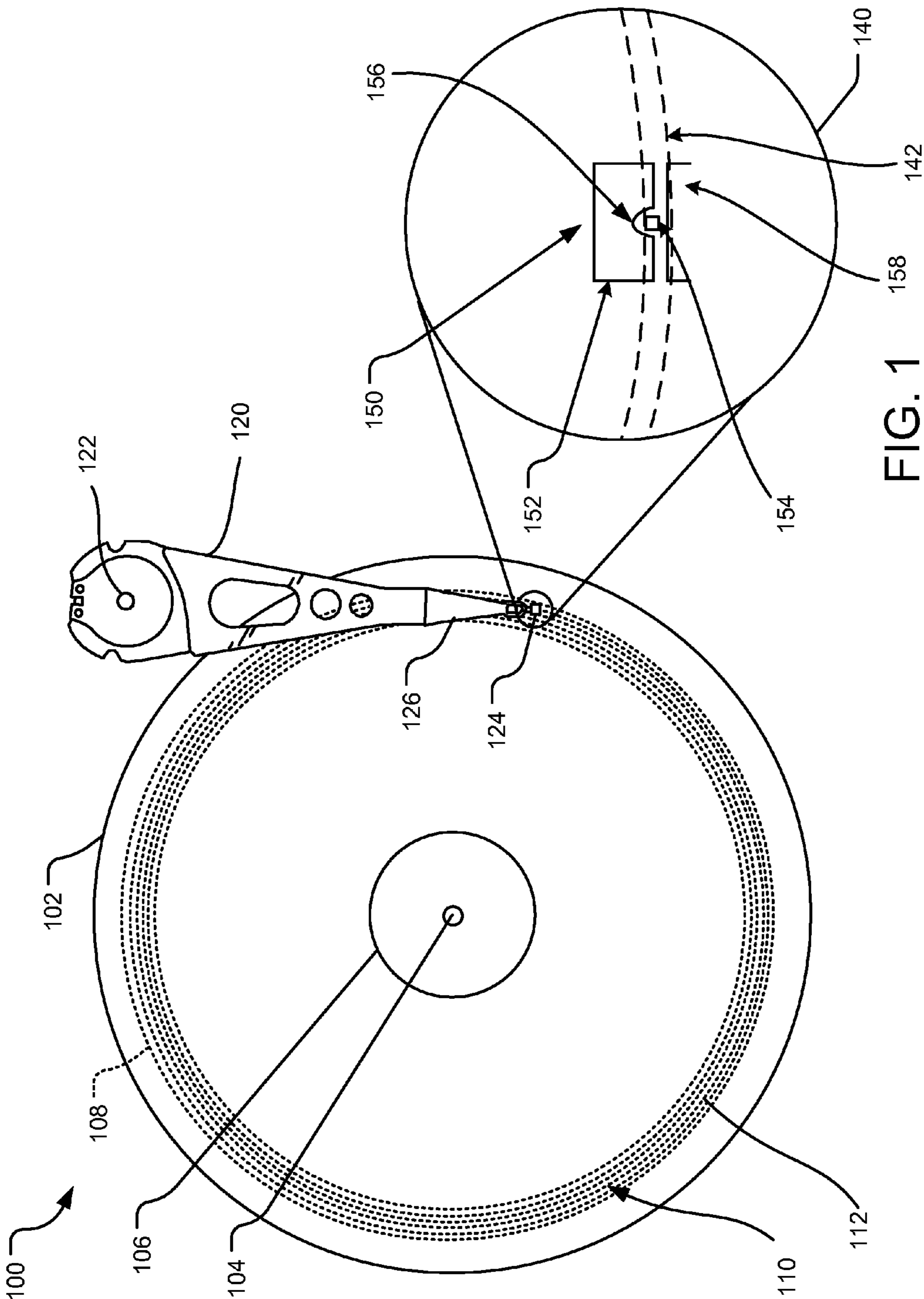

FIG. 1

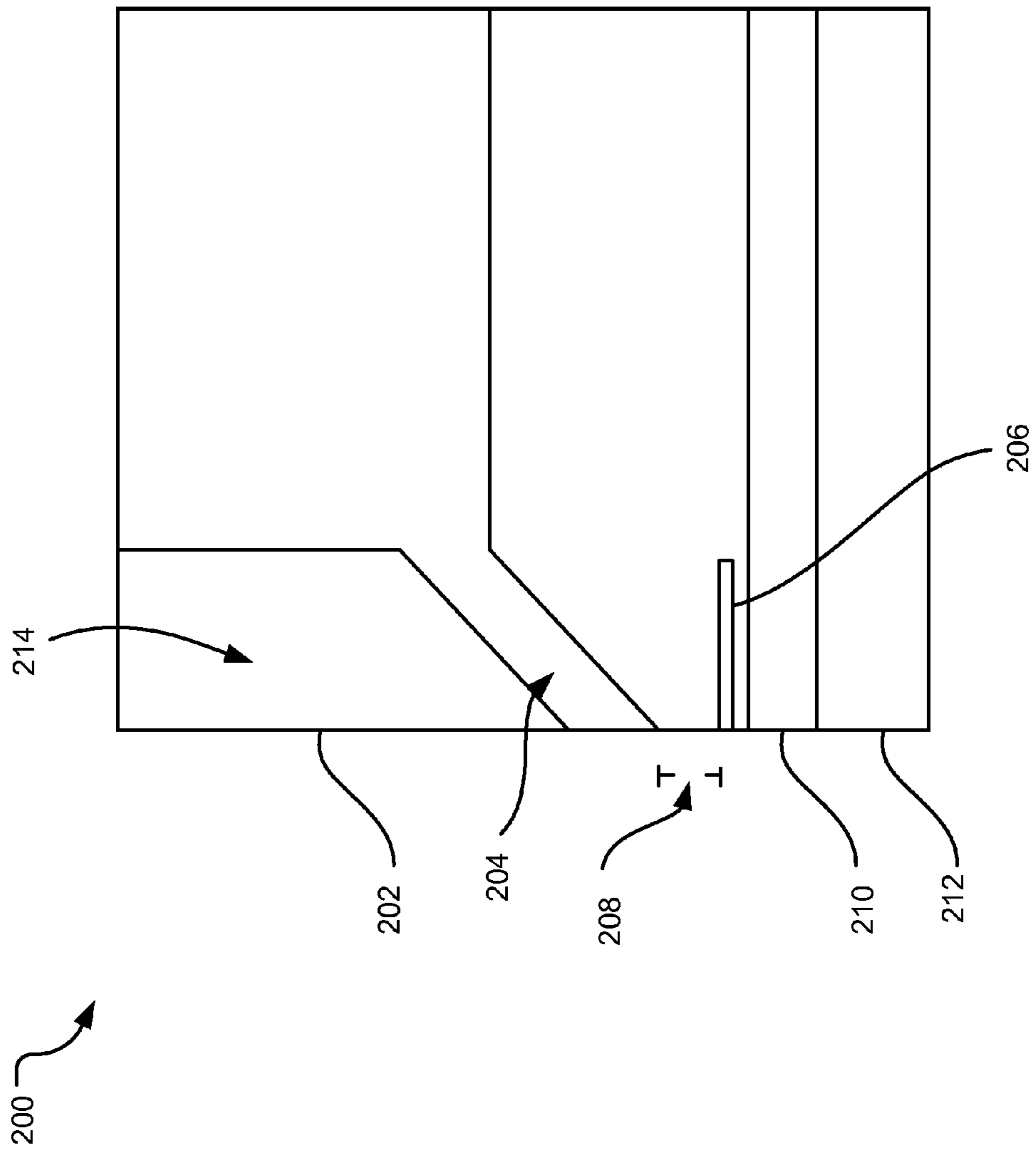

FIG. 2

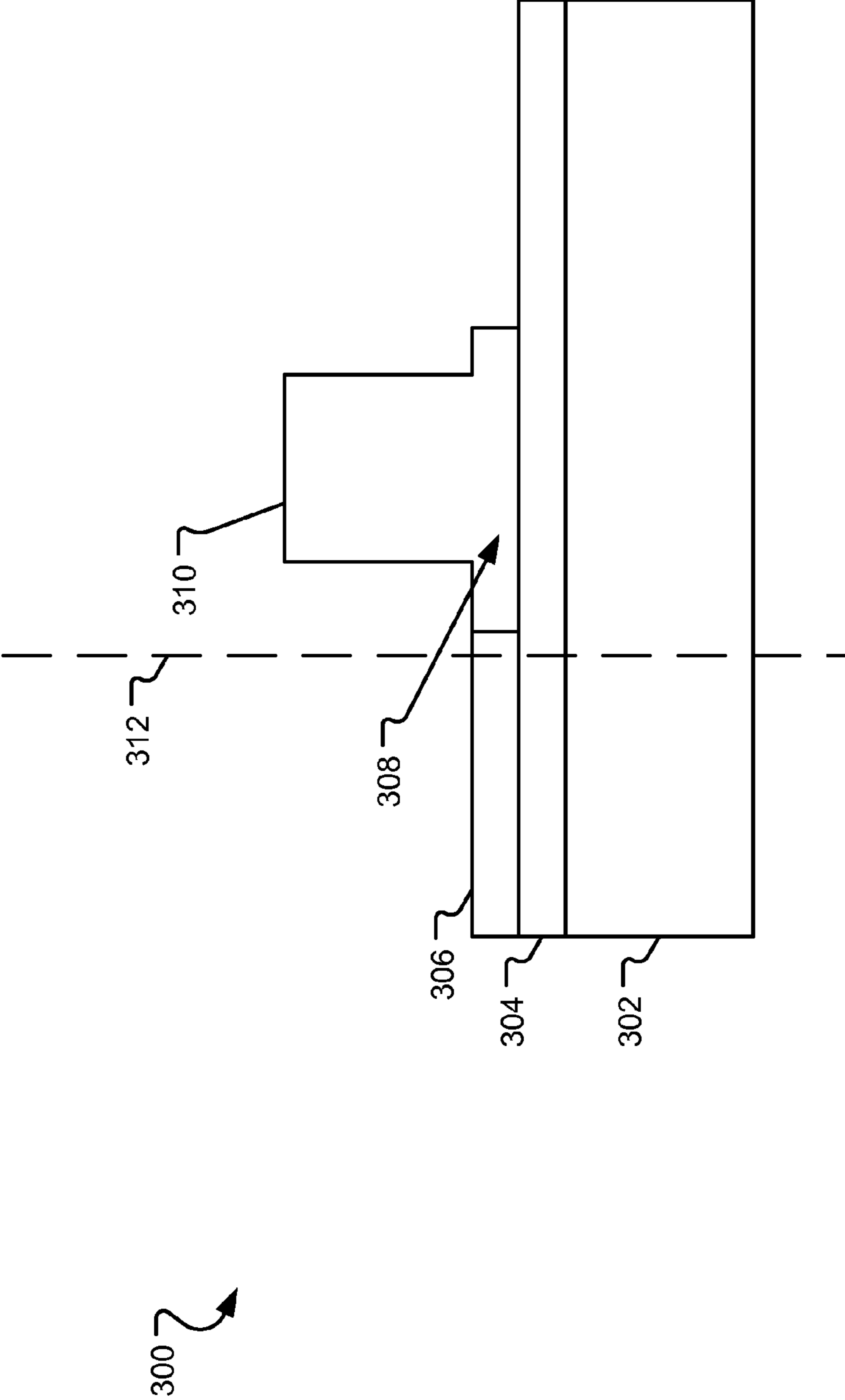

FIG. 3

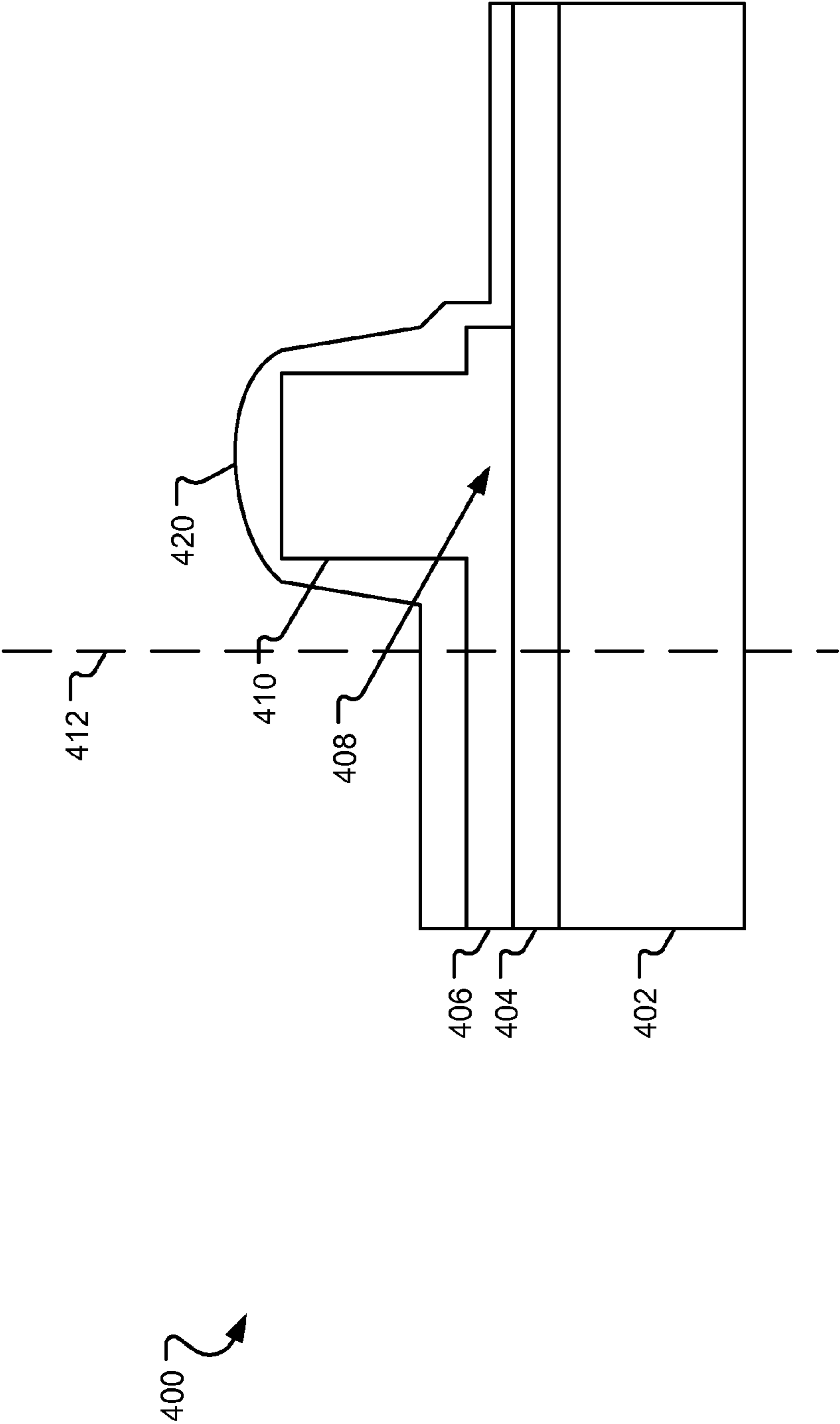

FIG. 4

500 ↗

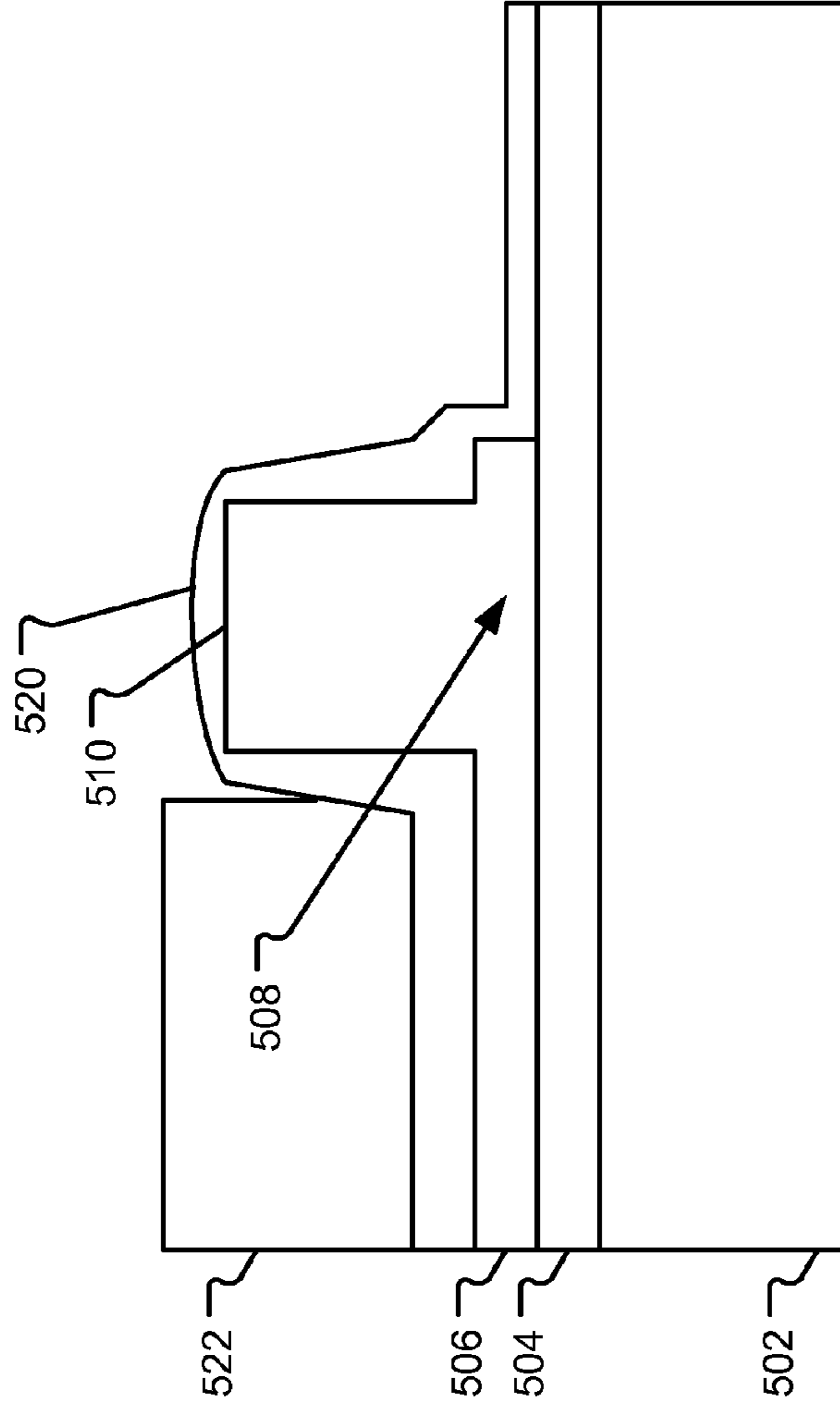

FIG. 5

600 ↗

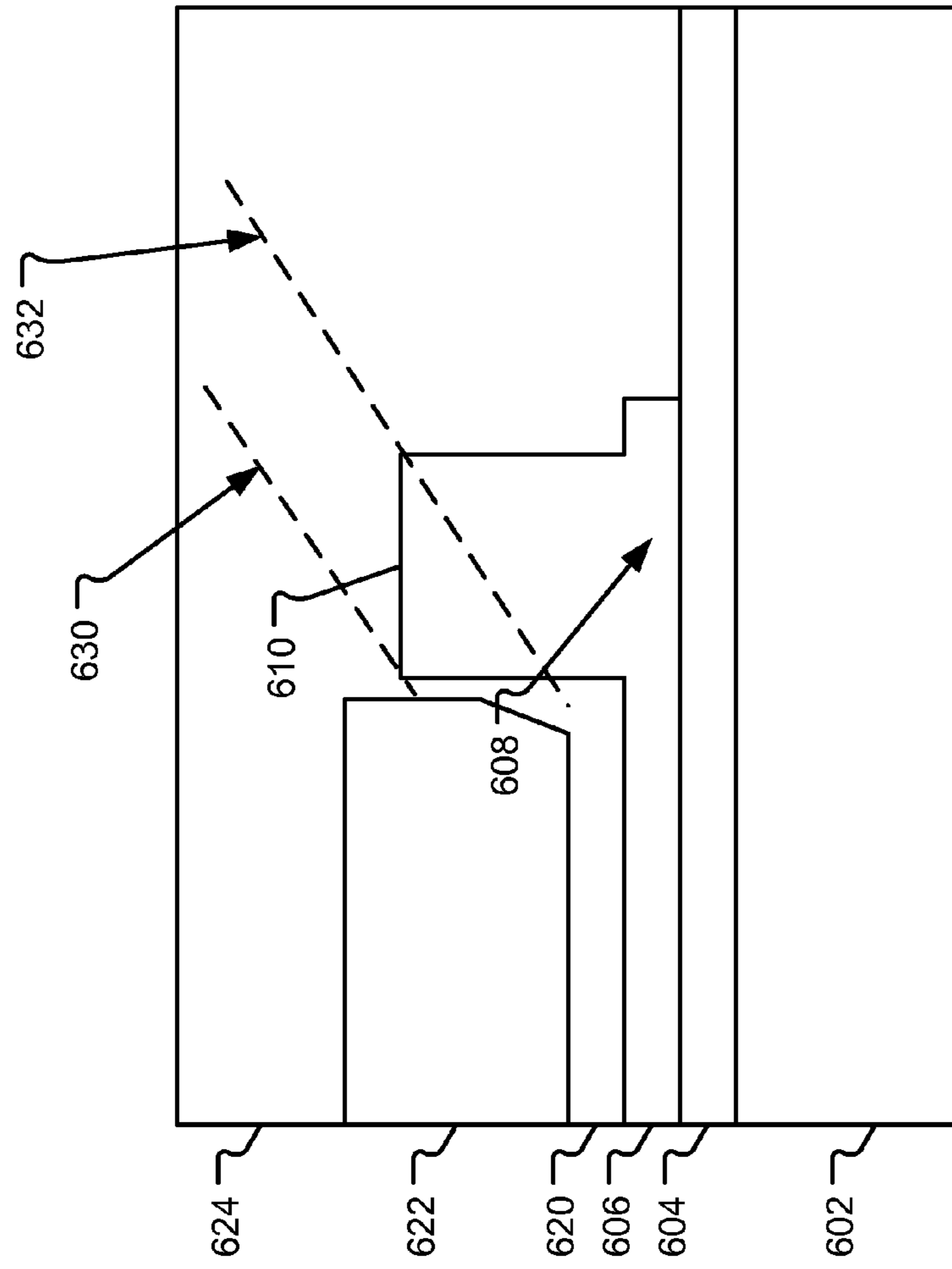

FIG. 6



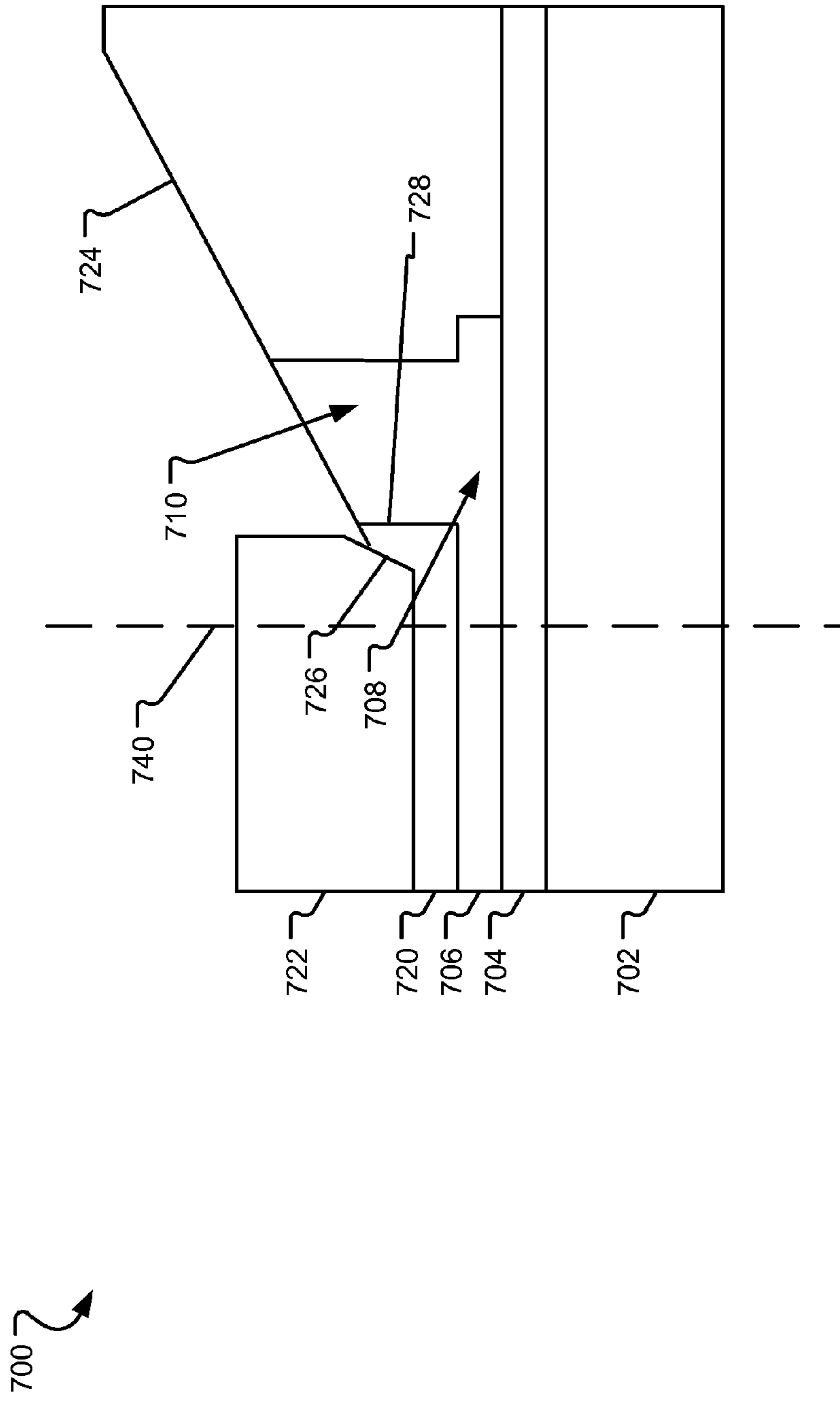

FIG. 7

800 ↗

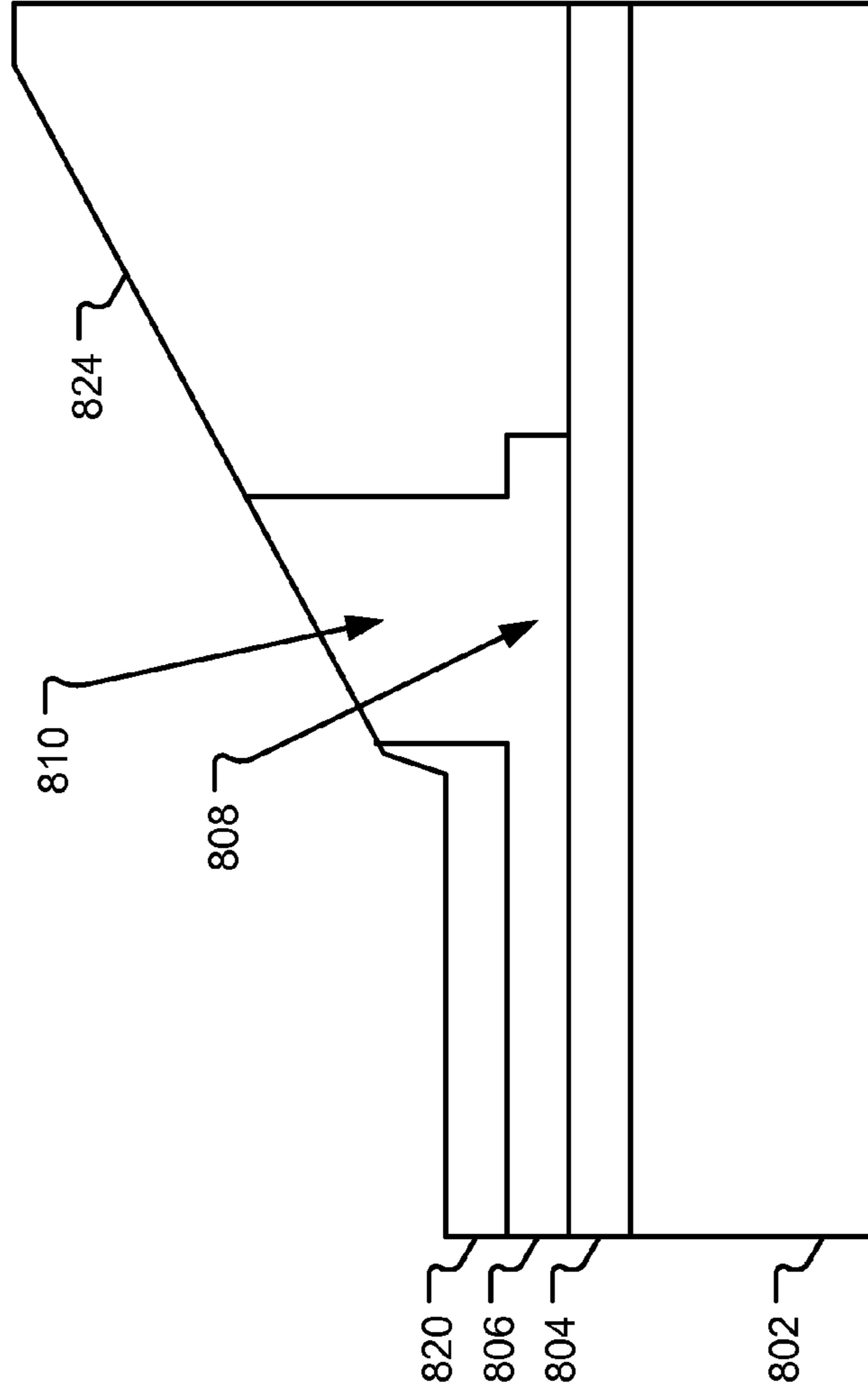

FIG. 8

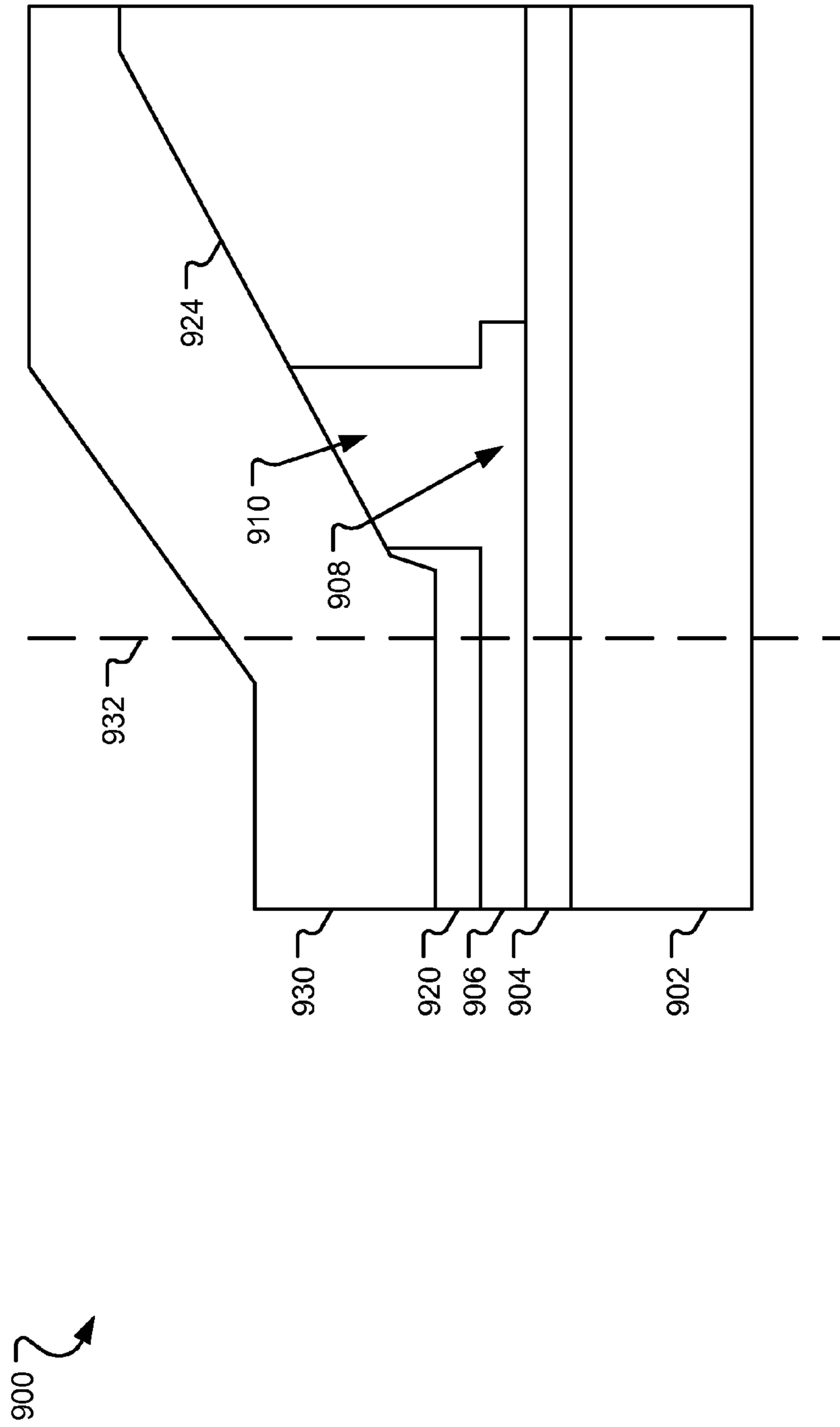

FIG. 9

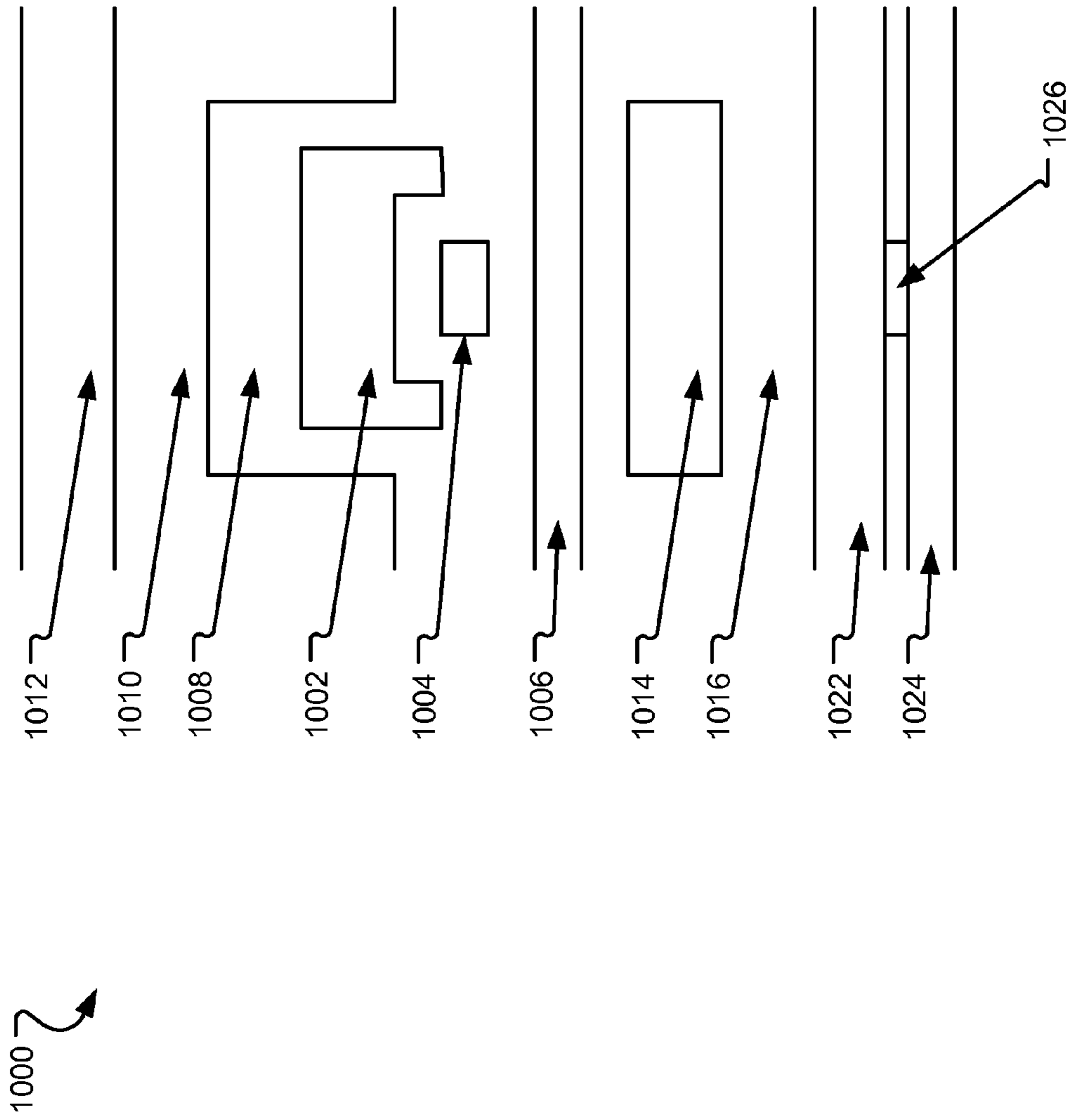

FIG. 10

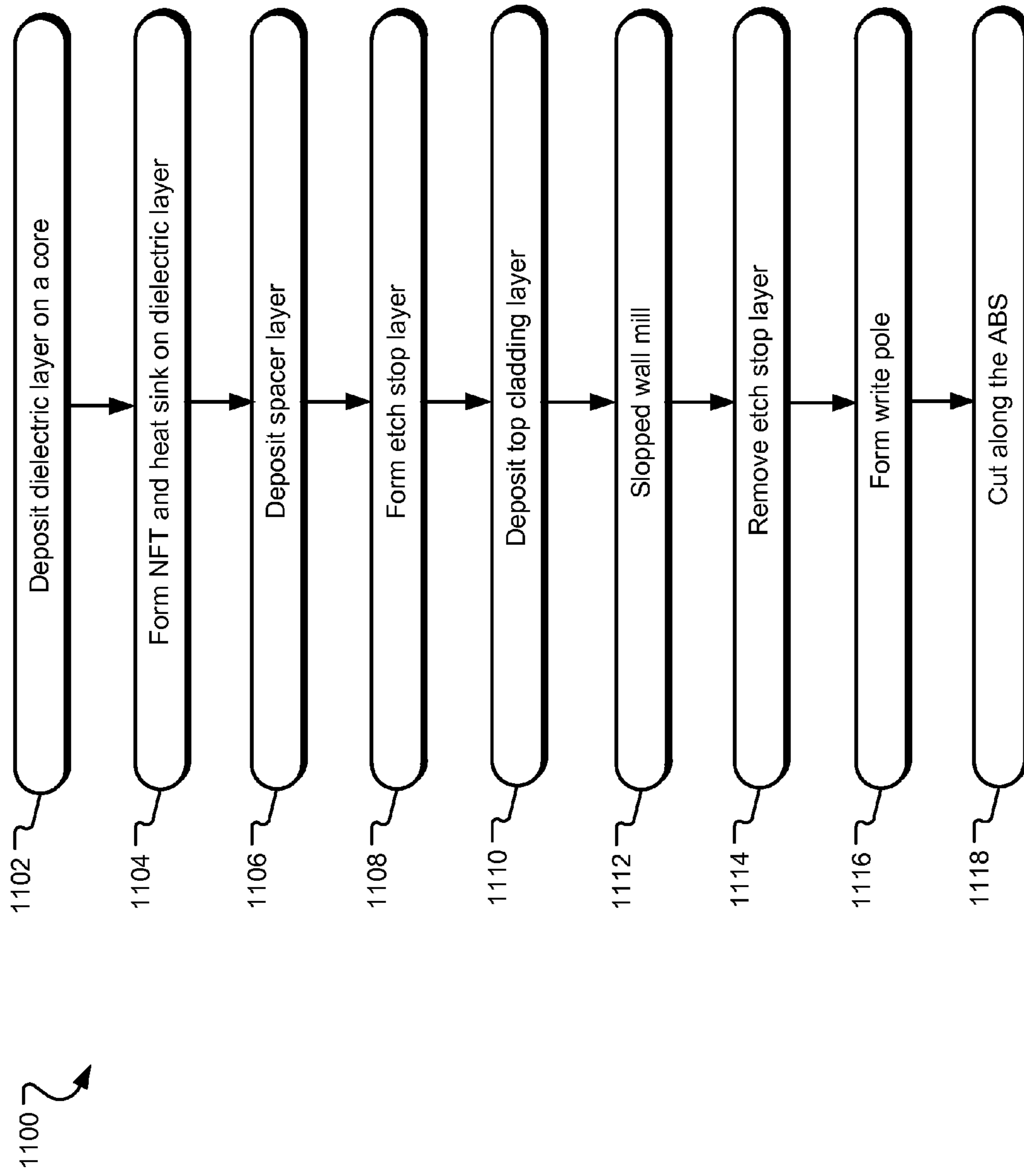

FIG. 11

# 1

## METHOD OF MAKING A TRANSDUCER HEAD

### CROSS-REFERENCE TO RELATED APPLICATION

The present application is a divisional application of U.S. patent application Ser. No. 13/794,133 filed Mar. 11, 2013, and titled "Method Of Making A Transducer Head", and expected to issue on Sep. 22, 2015 as U.S. Pat. No. 9,142,231, which is hereby incorporated by reference in its entirety.

### BACKGROUND

Thermally assisted magnetic recording or heat-assisted magnetic recording (HAMR) generally refers to the concept of locally heating a recording medium to reduce the coercivity of the medium. Such reduced coercivity allows the applied magnetic writing fields to more easily direct the magnetization within the recording medium during the temporary magnetic softening caused by the heat source. HAMR allows for the use of small grain media, with a larger magnetic anisotropy at room temperature to assure sufficient thermal stability, which is desirable for recording at increased areal densities. HAMR can be applied to any type of magnetic storage media including tilted media, longitudinal media, perpendicular media, and patterned media. By heating the media, the  $K_u$  or coercivity is reduced such that the magnetic write field is sufficient to write to the media. Once the media cools to ambient temperature, the coercivity has a sufficiently high value to assure thermal stability of the recorded information.

In HAMR, information bits are recorded on a data storage medium at elevated temperatures, and the data bit dimension can be determined by the dimensions of the heated area in the storage medium or the dimensions of an area of the storage medium that is subjected to a magnetic field. In one approach, a beam of light is condensed to a small optical spot onto the storage medium to heat a portion of the medium and reduce the magnetic coercivity of the heated portion. One example of a recording head for use in HAMR generally includes a write pole and a return pole magnetically coupled to each other through a yoke or pedestal, and a waveguide for focusing light onto the storage medium. The waveguide is positioned between the write pole and the return pole. Light is coupled into the waveguide above the yoke and is transmitted through the waveguide on opposite sides of the yoke.

### SUMMARY

This Summary is provided to introduce a selection of concepts in a simplified form that are further described below in the Detailed Description. This Summary is not intended to identify key features or essential features of the claimed subject matter, nor is it intended to be used to limit the scope of the claimed subject matter. Other features, details, utilities, and advantages of the claimed subject matter will be apparent from the following more particular written Detailed Description of various implementations and implementations as further illustrated in the accompanying drawings and defined in the appended claims.

A method of making a transducer head disclosed herein includes depositing a spacer layer on an NFT layer of the transducer head, forming an etch stop layer on a spacer layer of a transducer, depositing a cladding layer on the etch stop

# 2

layer, and milling the cladding layer at a sloped angle such that the milling stops at the etch stop layer.

### BRIEF DESCRIPTION OF THE DRAWINGS

The described technology is best understood from the following Detailed Description describing various implementations read in connection with the accompanying drawings. These drawings are for illustration purposes and one or more of the dimensions of these drawings may not be to scale.

FIG. 1 illustrates an example schematic representation of a recording device including a transducer head according to the implementations disclosed herein.

FIG. 2 illustrates an alternative schematic representation of a cross-sectional view of a portion of a transducer head according to the implementations disclosed herein.

FIG. 3 illustrates a stage in the process for forming a notched recording head according to the implementations disclosed herein.

FIG. 4 illustrates another stage in the process for forming a notched recording head according to the implementations disclosed herein.

FIG. 5 illustrates another stage in the process for forming a notched recording head according to the implementations disclosed herein.

FIG. 6 illustrates another stage in the process for forming a notched recording head according to the implementations disclosed herein.

FIG. 7 illustrates another stage in the process for forming a notched recording head according to the implementations disclosed herein.

FIG. 8 illustrates another stage in the process for forming a notched recording head according to the implementations disclosed herein.

FIG. 9 illustrates another stage in the process for forming a notched recording head according to the implementations disclosed herein.

FIG. 10 illustrates an alternative schematic representation of an air-bearing surface view of a transducer head according to the implementations disclosed herein.

FIG. 11 illustrates a flowchart of a process for manufacturing a transducer head disclosed herein.

### DETAILED DESCRIPTION

FIG. 1 illustrates a perspective view of an example recording device **100** including a transducer head using an NFT according to the implementations disclosed herein. The recording device **100** includes a disc **102**, which rotates about a spindle center or a disc axis of rotation **104** during operation. The disc **102** includes an inner diameter **106** and an outer diameter **108** between which are a number of concentric data tracks **110**, illustrated by circular dashed lines. The data tracks **110** are substantially circular and are made up of regularly spaced patterned bits **112**, indicated as dots or ovals on the disc **102** as well as in an exploded view **140**. It should be understood, however, that the described technology may be employed with other types of storage media, including continuous magnetic media, discrete track (DT) media, etc.

Information may be written to and read from the bits **112** on the disc **102** in different data tracks **110**. A transducer head **124** is mounted on an actuator assembly **120** at an end distal to an actuator axis of rotation **122** and the transducer head **124** flies in close proximity above the surface of the disc **102** during disc operation. The actuator assembly **120**

rotates during a seek operation about the actuator axis of rotation **122** positioned adjacent to the disc **102**. The seek operation positions the transducer head **124** over a target data track of the data tracks **110**.

The exploded view **140** illustrates data tracks **142** and a transducer head **150** (not to scale) located over the data tracks. The example transducer head **150** includes a write pole **152** and a near field transducer (NFT) **154** located near the write pole **152**. In the example implementation, the surface of the write pole **152** facing the NFT **154** has a notch **156**. In the illustrated implementation, the notch **156** has a curved shape. However, in an alternative implementation, the notch **156** may have other shape, such as a rectangular shape, a square shape, a triangular shape, etc. Alternatively, the write pole **152** may have a flat surface without a notch. In the illustrated implementation, the NFT **154** is positioned in the notch **156** such that the NFT intersects the surface of the write pole **152** facing the NFT **154**.

The transducer head **150** also includes a core **158** that is located on the other side of the NFT **154** from the write pole **152**. The transducer head **150** may also include other components, such as top cladding, lower shield, reader sensor, top shield, heat sink, etc., that are not shown in the illustrated implementation of the transducer head **150**. The distance between the innermost point of the notch **156** and the NFT **154** is referred to herein as the NFT-to-pole spacing (NPS). On the other hand, the distance between the surface of the write pole **152** facing the NFT and the core **158** is referred to as the core-to-pole spacing (CPS). Various processes discussed in this application allow controlling the NPS and/or the CPS using a spacer layer during the manufacturing of the transducer head **150**.

FIG. **2** illustrates an alternative schematic representation of a cross-sectional view of a portion of a transducer head **200** according to the implementations disclosed herein. Specifically, FIG. **2** illustrates the transducer head **200** having an air-bearing surface **202** that faces recording medium. The transducer head **200** includes a write pole **204** separated by an NFT **206** by a NPS distance of **208**. In one implementation of the transducer head **200**, the NFT **206** also includes an NFT heat sink. Additionally, the transducer head **200** may also include a core **210**, a cladding **212**, and an optional heat sink **214**. It is typically difficult to control the NPS distance **208** at the ABS **202**. Various processes discussed in this application allow controlling the NPS distance **208** using a spacer layer during the manufacturing of the transducer head **150**.

FIG. **3** illustrates a stage in the process for forming a notched recording head according to the implementations disclosed herein. Specifically, FIG. **3** illustrates a partial transducer head **300** with a core **302** with a thin layer **304** of dielectric material disposed thereupon. The partial transducer head **300** also includes an NFT with an NFT peg **306**, an NFT disc **308**, and an NFT heat sink **310**. While the implementation of the partial transducer head **300** illustrates the NFT heat sink **310** to have a rectangular shape, in other implementations the NFT heat sink **310** may also have other shape, such as trapezoidal, etc. In one implementation, the partial transducer head **300** is lapped along an air-bearing surface (ABS) **312** such that a part of the NFT peg **306** is exposed to the ABS **312**.

FIG. **4** illustrates another stage in the process for forming a notched recording head according to the implementations disclosed herein. Specifically, FIG. **4** illustrates a partial transducer head **400** with a core **402** with a thin layer **404** of dielectric material disposed thereupon. The partial transducer head **400** also includes an NFT with an NFT peg **406**,

an NFT disc **408**, and an NFT heat sink **410**. The partial transducer **400** may be lapped along an air-bearing surface (ABS) **412** such that a part of the NFT peg **406** is exposed to the ABS **412**. The partial transducer **400** also includes a spacer layer **420** deposited on the NFT and the heat sink **410**. In one implementation, the spacer layer **420** may be made of an oxide of Aluminum. However, other material such as silicon oxide or other suitable material may also be used for the spacer layer **420**. In one implementation of the transducer, an atomic layer deposition (ALD) process is used to deposit the spacer layer **420**. However, in alternative implementations, other deposition process may be used to deposit the spacer layer **420**. Specifically, the spacer layer **420** is introduced during the manufacturing of the transducer to control the pole to core spacing or the pole to NFT spacing at the ABS **412**. The thickness of the spacer layer **420** may be accurately controlled and/or varied by the ALD process.

FIG. **5** illustrates another stage in the process for forming a notched recording head according to the implementations disclosed herein. Specifically, FIG. **5** illustrates a partial transducer head **500** with a core **502** with a thin layer **504** of dielectric material disposed thereupon. The partial transducer head **500** also includes an NFT with an NFT peg **506**, an NFT disc **508**, and an NFT heat sink **510**. The partial transducer **500** also includes a spacer layer **520** deposited on the NFT and the heat sink **510**. Furthermore, a photo resist (PR) etch stop layer **522** is formed on at least part of the spacer layer **520**.

Alternatively, the etch stop layer **522** may be made of a patterned etch-stop structure made of a thin amorphous carbon (a-C) material. Specifically, such a-C pattern may be made by a process flow including deposition, lithography, and etch process flow. Alternatively, the a-C pattern may be made of a process flow including lithography, deposition, and liftoff. The etch stop layer **522** made of a-C may be cleanly removed by O<sub>2</sub> ash. Yet alternatively, the etch stop layer **522** may be made of a metal. Such metal etch stop layer **522** provides high selectivity during a subsequent slope wall milling process. An example of such metal etch stop layer may be a chromium (Cr) etch stop layer. Such Cr etch stop layer may be later removed by a Cr wet etching process. In alternative implementations, other metals may also be used for forming the etch stop layer **522**.

FIG. **6** illustrates another stage in the process for forming a notched recording head according to the implementations disclosed herein. Specifically, FIG. **6** illustrates a partial transducer head **600** with a core **602** with a thin layer **604** of dielectric material disposed thereupon. The partial transducer head **600** also includes an NFT with an NFT peg **606**, an NFT disc **608**, and an NFT heat sink **610**. The partial transducer **600** also includes a spacer layer **620** deposited on the NFT and the heat sink **610**. Furthermore, a photo resist (PR) etch stop layer **622** is formed on at least part of the spacer layer **620**. In addition, the transducer head **600** also includes a top cladding layer **624**. In one implementation, the top cladding layer is made of the same material as the spacer layer **620**.

After the deposition of the top cladding layer **624**, the cladding layer **624** and the NFT heat sink **610** are etched using a reactive ion beam etching process in the direction illustrated by the lines **630**, **632**. Specifically, providing the PR etch stop layer **622** allows the etching to be completed in such a manner such that the NFT-to-pole spacing (NPS) at the ABS can be controlled. Specifically, providing the PR etch stop layer **622** allows the precise positioning of a sloped wall etch to vary as illustrated in FIG. **6**, and still control the NPS at the ABS. In other words the quality of the NPS is

## 5

protected even with the variation of etching from **632** to **630**. In one implementation, the etching is accomplished using sloped wall mill process.

FIG. **7** illustrates another stage in the process for forming a notched recording head according to the implementations disclosed herein. Specifically, FIG. **7** illustrates a partial transducer head **700** with a core **702** with a thin layer **704** of dielectric material disposed thereupon. The partial transducer head **700** also includes an NFT with an NFT peg **706**, an NFT disc **708**, and an NFT heat sink **710**. The partial transducer head **700** illustrates a partial cladding layer **724** that remains on the transducer head **700** after an etching process that removes part of the cladding layer **724** and the heat sink **710**. The partial transducer head **700** also includes a PR etch stop layer **722**. In an implementation, a surface **726** of the PR etch stop layer **722** facing the NFT heat sink **722** may be parallel to the surface **728** of the NFT heat sink **722** facing the PR etch stop layer **722**. As a result, when the cladding layer **724** is etched, the resulting space between the NFT peg **706** and a write pole (not shown) at an ABS **740** is substantially constant irrespective of the position of the etching of the cladding layer **724** and the heat sink **710** or the position of the ABS **740** along the length of the NFT.

FIG. **8** illustrates another stage in the process for forming a notched recording head according to the implementations disclosed herein. Specifically, FIG. **8** illustrates a partial transducer head **800** with a core **802** with a thin layer **804** of dielectric material disposed thereupon. The partial transducer head **800** also includes an NFT with an NFT peg **806**, an NFT disc **808**, and an NFT heat sink **810**. As illustrated in FIG. **8**, the partial transducer head **800** does not include any PR layer as the PR layer is removed by a strip and an oxygen etching process. In one implementation where the etch stop layer is made of photo resist material, the etch stop removal process may be implemented using an oxygen ash and strip. Alternatively, where the etch stop layer is made of amorphous carbon, the etch stop removal process may use oxygen ash to remove the etch stop layer. Yet alternatively, where the etch stop layer is made of chromium, the etch stop removal process may be implemented using a chromium wet etch process.

Subsequent to the etch stop removal process, the partial transducer **800** includes a spacer layer **820** on top of the NFT peg **806** and the heat sink material **810**. Additionally, the partial transducer **800** also includes cladding layer **824** deposited on the dielectric material **804** and the heat sink **810**.

FIG. **9** illustrates another stage in the process for forming a notched recording head according to the implementations disclosed herein. Specifically, FIG. **9** illustrates a partial transducer head **900** with a core **902** with a thin layer **904** of dielectric material disposed thereupon. The partial transducer head **900** also includes an NFT with an NFT peg **906**, an NFT disc **908**, and an NFT heat sink **910**. Additionally, the partial transducer **900** includes a spacer layer **920** on top of the NFT peg **906** and the heat sink material **910** and a cladding layer **924** deposited on the dielectric material **904** and the heat sink **910**. A write pole layer **930** is formed on the top surface of the partial transducer **900** such that the write pole layer **930** is in contact with the spacer layer **920**, the heat sink **910**, and the cladding layer **924**. The partial transducer **900** may be lapped along the ABS **932** such that the spacer layer **920** provides the NPS between the write pole **930** and the NFT peg **920** at the ABS **932**.

FIG. **10** illustrates an alternative schematic representation (not to scale) of an air-bearing surface (ABS) view **1000** of a transducer head according to the implementations dis-

## 6

closed herein. Specifically, the ABS view **1000** discloses a write pole **1002** with a notched surface facing an NFT **1004** and a core layer **1006**. The write pole **1002** may be surrounded by a heat sink material **1008** and separated from a first return pole **1012** by a cladding layer **1010**. The transducer head **1000** also includes another return pole **1014** that is separated by a bottom cladding layer **1016** from the core **1006**. Furthermore, a reader structure of the transducer head **1000** also includes a top shield **1022** and a bottom shield **1024** on opposite sides of a reader sensor **1026**. The spacing between the NFT **1004** and the write pole **1002**, also referred to as the NFT-to-pole spacing (NPS), is controlled during the manufacturing of the transducer head **1000** by using a spacer layer and a photo resist.

FIG. **11** illustrates a flowchart of a process **1100** for manufacturing a transducer head disclosed herein. Specifically, the process **1100** includes various operations for manufacturing a transducer head while controlling the NFT-to-pole spacing (NPS). The manufacturing of the transducer head may start with a core layer, which may be made of Ta<sub>2</sub>O<sub>5</sub> or other similar material. An operation **1102** deposits a thin dielectric layer on the core layer. Subsequently, an operation **1104** forms the NFT and heat sink layer on the dielectric layer. The NFT may be for example, a lollipop type NFT with a peg and a disc. The heat sink may be made of a non-magnetic material, such as for example Au.

Subsequently, an operation **1106** deposits a spacer layer on the NFT, heat sink, and the dielectric layer. The thickness of the spacer layer may be accurately controlled and varied by an atomic layer deposition (ALD) process. Following the deposition of the spacer layer an operation **1108** forms an etch stop layer on the spacer layer. In one implementation, the etch stop layer is a single photo resist (PR) layer. The placement of the etch stop can be very well controlled using advanced lithography processes and the precision in the placement of the etch stop layer as a single photo resist is limited only by the capability of such advanced lithography process.

Alternatively, the etch stop layer may be made of a patterned etch-stop structure made of a thin amorphous carbon (a-C) material. Specifically, such a-C pattern may be made by a process flow including deposition, lithography, and etch process flow. Alternatively, the a-C pattern may be made of a process flow including lithography, deposition, and liftoff. The etch stop layer made of a-C may be cleanly removed by O<sub>2</sub> ash. Yet alternatively, the etch stop layer may be made of a metal. Such metal etch stop layer provides high selectivity during a subsequent slope wall milling process. An example of such metal etch stop may be a chromium (Cr) etch stop. Such Cr etch stop may be later removed by a Cr wet etching process.

After forming of the etch stop layer, an operation **1110** deposits a top cladding layer. Subsequently, an operation **1112** removes parts of the top cladding and the heat sink material using a sloped wall milling process. In one implementation, the angle of the sloped wall milling process is such that the spacer layer between the etch stop layer and the NFT is not milled. The spacer layer is protected from being milled because of the etch stop layer. As a result of the sloped wall milling process, the etch stop layer remains in place over the spacer layer. Subsequently, an operation **1114** is used to remove the etch stop layer. The removal of the etch stop layer results in a partial transducer head that has a uniform spacer layer on top of an NFT peg.

Furthermore, the slope of the remaining spacer layer resulting from the sloped mill process and the slope of the heat sink layer are such that irrespective of the positioning



7

of the air-bearing surface (ABS) along the length of the transducer the thickness of the spacer layer remains substantially constant. Such substantially constant thickness of the spacer layer allows for substantially uniform NFT-to-pole spacing (NPS) in the resulting transducer at the ABS. An operation 1116 forms a write pole layer on top of the spacer layer, the sloped pole heat sink layer and the sloped top cladding layer. In one implementation, the write pole layer may be made of a magnetic material such as CoNiFe, etc. After forming of the write pole, an operation 1118 cuts the partial transducer head along an air-bearing surface (ABS) such that the NPS is preserved to a desired value.

The above specification, examples, and data provide a complete description of the structure and use of exemplary embodiments of the invention. Since many embodiments of the invention can be made without departing from the spirit and scope of the invention, the invention resides in the claims hereinafter appended. Furthermore, structural features of the different embodiments may be combined in yet another embodiment without departing from the recited claims. Although the present invention has been described with reference to preferred embodiments, workers skilled in the art will recognize that changes may be made in form and detail without departing from the scope of the invention. The implementations described above and other implementations are within the scope of the following claims.

What is claimed is:

1. A partial transducer head, comprising:
  - a core layer;
  - a spacer layer;
  - a near field transducer (NFT) layer; and
  - an etch stop layer formed at least partially on the spacer layer.
2. The partial transducer head of claim 1, further comprising a write pole formed on the etch stop layer.
3. The partial transducer head of claim 1, wherein the etch stop layer is made of amorphous carbon.
4. The partial transducer head of claim 1, wherein the etch stop layer is made of at least one of (i) metal and (ii) photo resist.
5. The partial transducer of claim 2, wherein the write pole is surrounded by heat sink material.

8

6. The partial transducer of claim 5, wherein the write pole is separated from a first return pole by a cladding layer.

7. The partial transducer of claim 5, wherein the write pole has a notched surface facing the NFT.

8. A transducer head, comprising:

a write pole with a notched surface facing a near field transducer (NFT); and

a heat sink layer surrounding the write pole at an air-bearing surface (ABS) of the transducer head, wherein the spacing between the NFT and the write pole is controlled during the manufacture of the transducer head by using a spacer layer and a photo resist.

9. The transducer head of claim 8, wherein the write pole is separated from a first return pole by a cladding layer.

10. The transducer head of claim 8, further comprising a core layer separating the NFT from a second return pole.

11. The transducer head of claim 10, further comprising a read sensor separated from the second return pole by a top shield.

12. The transducer head of claim 8, wherein the notched surface of the write pole has a curved shape.

13. The transducer head of claim 8, wherein the NFT intersects a surface of the write pole facing the NFT.

14. The transducer head of claim 8, wherein the notched surface of the write pole has a rectangular shape.

15. The transducer head of claim 8, wherein the notched surface of the write pole has a triangular shape.

16. A partial transducer head, comprising:

a spacer layer;

a near field transducer (NFT) layer; and

an etch stop layer formed at least partially on the spacer layer.

17. The partial transducer head of claim 16, further comprising a core layer on the opposite side of the NFT from the side having a write pole layer.

18. The partial transducer head of claim 16, further comprising a cladding layer deposited on the etch stop layer.

19. The partial transducer head of claim 18, wherein the cladding layer is milled at a sloped angle.

\* \* \* \* \*