



US009431778B1

(12) **United States Patent**  
**Mueller et al.**

(10) **Patent No.:** **US 9,431,778 B1**  
(45) **Date of Patent:** **Aug. 30, 2016**

(54) **DUST TOLERANT CONNECTORS**

(71) Applicant: **The United States of America as Represented by the Administrator of the National Aeronautics and Space Administration, Washington, DC (US)**

(72) Inventors: **Robert P. Mueller, Cocoa Beach, FL (US); Mark E. Lewis, Merritt Island, FL (US); Gary L. Bastin, Palm Bay, FL (US); Matthew C. Branch, Rockledge, FL (US); Jeffrey W. Carlson, Merritt Island, FL (US); Adam G. Dokos, Titusville, FL (US); Kevin A. Murtland, Mims, FL (US); Matthew W. Nugent, Oviedo, FL (US); Gabor J. Tamasy, Melbourne, FL (US); Ivan I. Townsend, III, Cocoa, FL (US)**

(73) Assignee: **The United States of America as Represented by the Administrator of the National Aeronautics and Space Administration, Washington, DC (US)**

(\*) Notice: Subject to any disclaimer, the term of this patent is extended or adjusted under 35 U.S.C. 154(b) by 148 days.

(21) Appl. No.: **14/207,472**

(22) Filed: **Mar. 12, 2014**

**Related U.S. Application Data**

(60) Provisional application No. 61/778,387, filed on Mar. 12, 2013, provisional application No. 61/779,292, filed on Mar. 13, 2013, provisional application No. 61/779,200, filed on Mar. 13, 2013, provisional application No. 61/779,367, filed on Mar. 13, 2013, provisional application No. 61/779,045, filed on Mar. 13, 2013.

(51) **Int. Cl.**  
**H01R 13/44** (2006.01)  
**H01R 13/713** (2006.01)

**H01R 13/00** (2006.01)  
**H01R 13/447** (2006.01)  
**H01R 13/52** (2006.01)

(52) **U.S. Cl.**  
CPC ..... **H01R 13/713** (2013.01); **H01R 13/00** (2013.01); **H01R 13/447** (2013.01); **H01R 13/5213** (2013.01)

(58) **Field of Classification Search**  
USPC ..... 439/135, 136, 142  
See application file for complete search history.

(56) **References Cited**

**U.S. PATENT DOCUMENTS**

3,982,804	A *	9/1976	Marechal	.....	H01R 13/645 439/139
5,582,521	A *	12/1996	Mori	.....	B60L 11/1818 439/142
5,743,752	A *	4/1998	Massebeuf	.....	H01R 13/447 220/242
5,980,278	A *	11/1999	Winkler	.....	H01R 13/5219 439/142
6,039,602	A *	3/2000	Witkowski	.....	H01R 23/10 439/550
7,201,590	B1 *	4/2007	Chen	.....	H01R 13/5205 439/142

(Continued)

*Primary Examiner* — Tho D Ta

(74) *Attorney, Agent, or Firm* — Michelle L. Ford; B. Delano Jordan

(57) **ABSTRACT**

Methods and systems may provide for debris exclusion and removal apparatuses for connectors which have inverting end caps with a multi-axis lever configuration, inverting end caps with enlarged handle and/or side rail configurations, rotating end cap configurations, poppet valve configurations, O-ring configurations, filament barrier configurations, retractable cover configurations, clamshell end cap configurations, or any combination thereof. Apparatuses may also provide for an intelligent electrical connector system capable of detecting damage to or faults within a plurality of conductors and then rerouting the energy through a non-damaged spare conductor.

**20 Claims, 40 Drawing Sheets**

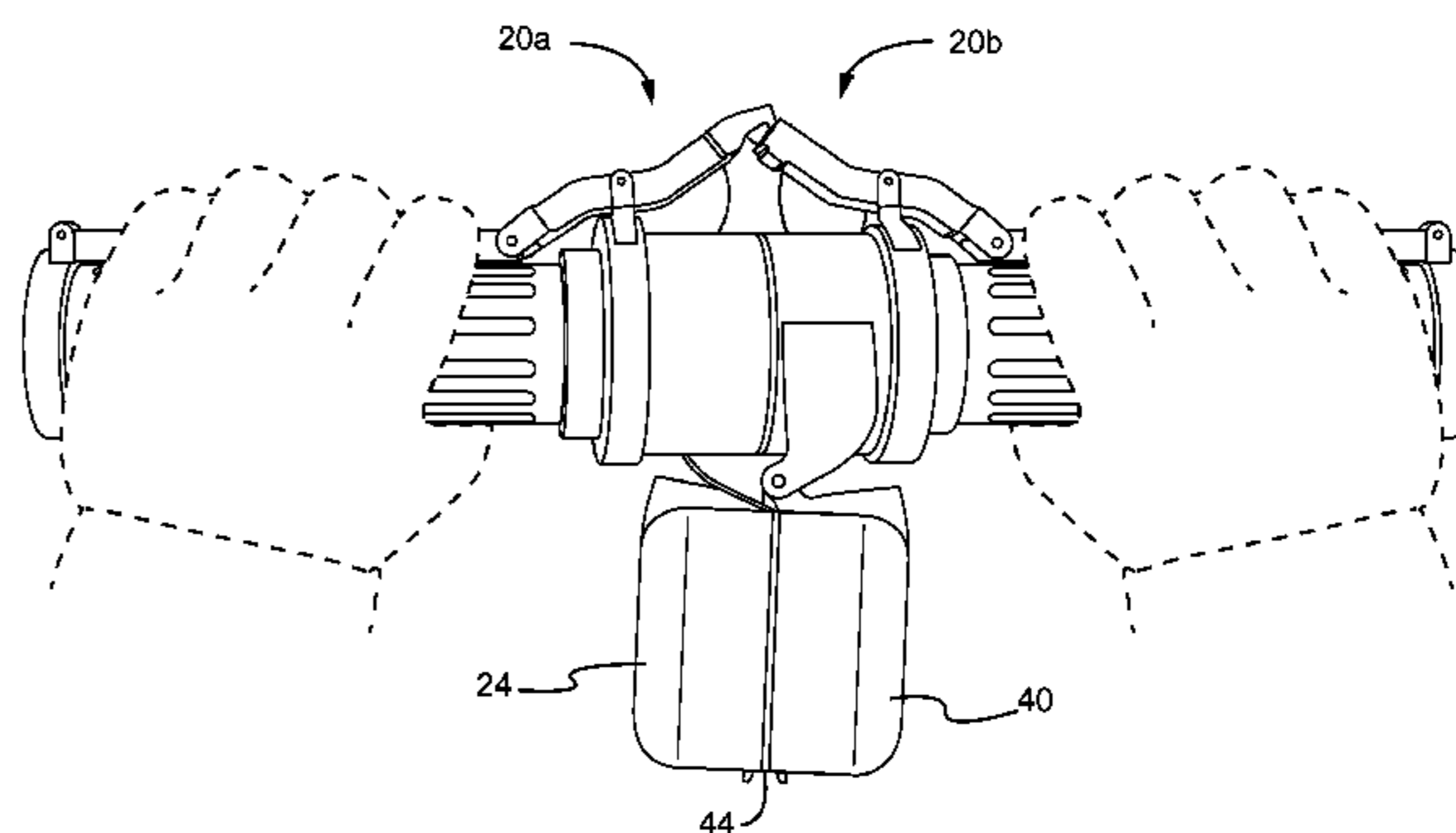
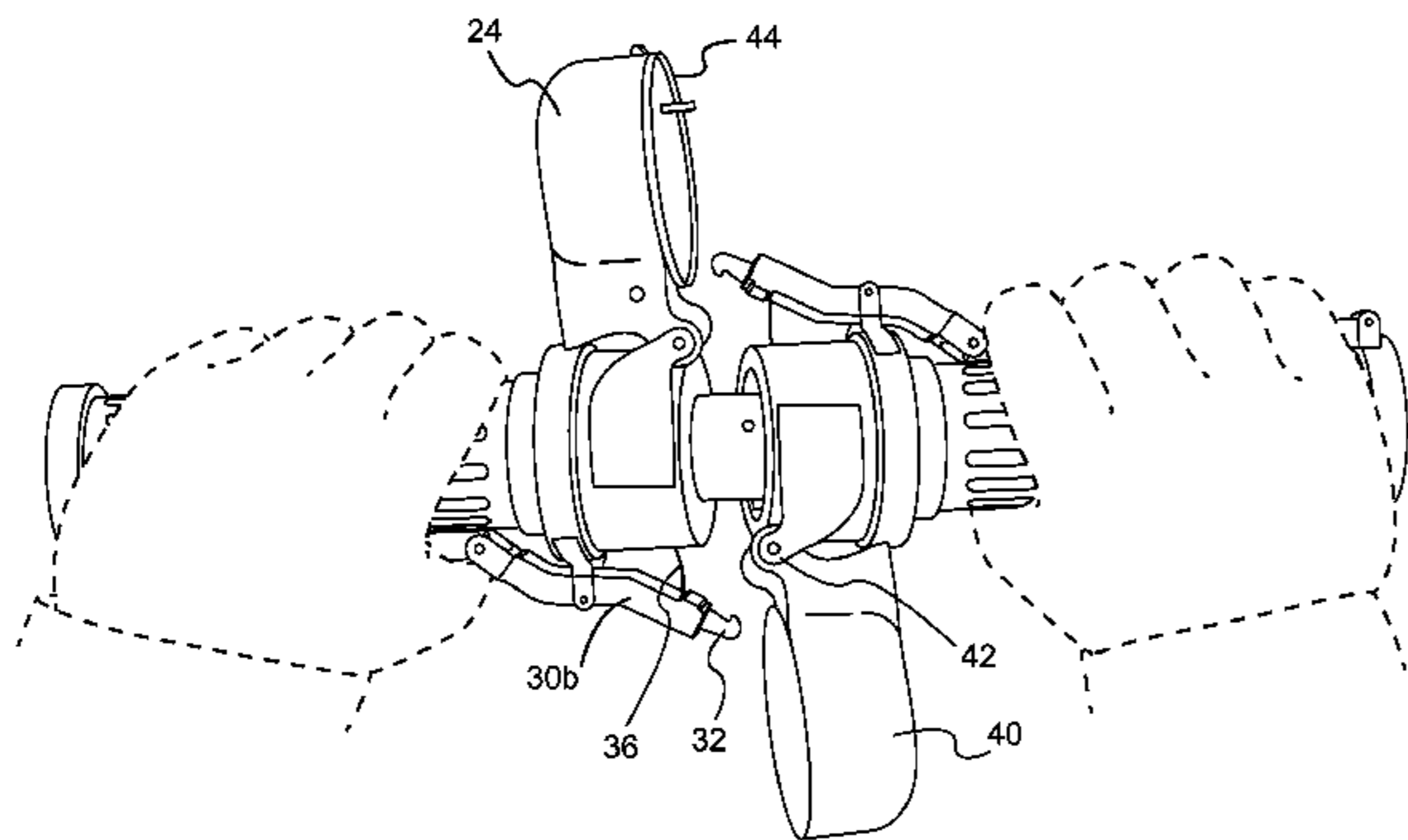

# US 9,431,778 B1

Page 2

---

(56)

## References Cited

### U.S. PATENT DOCUMENTS

2010/0136808 A1*	6/2010	Vanzo .....	H01R 13/625 439/118
2011/0021057 A1*	1/2011	Katagiyama .....	H01R 13/625 439/345
7,470,858 B2*	12/2008	McNutt .....	H01R 13/447 174/135

\* cited by examiner

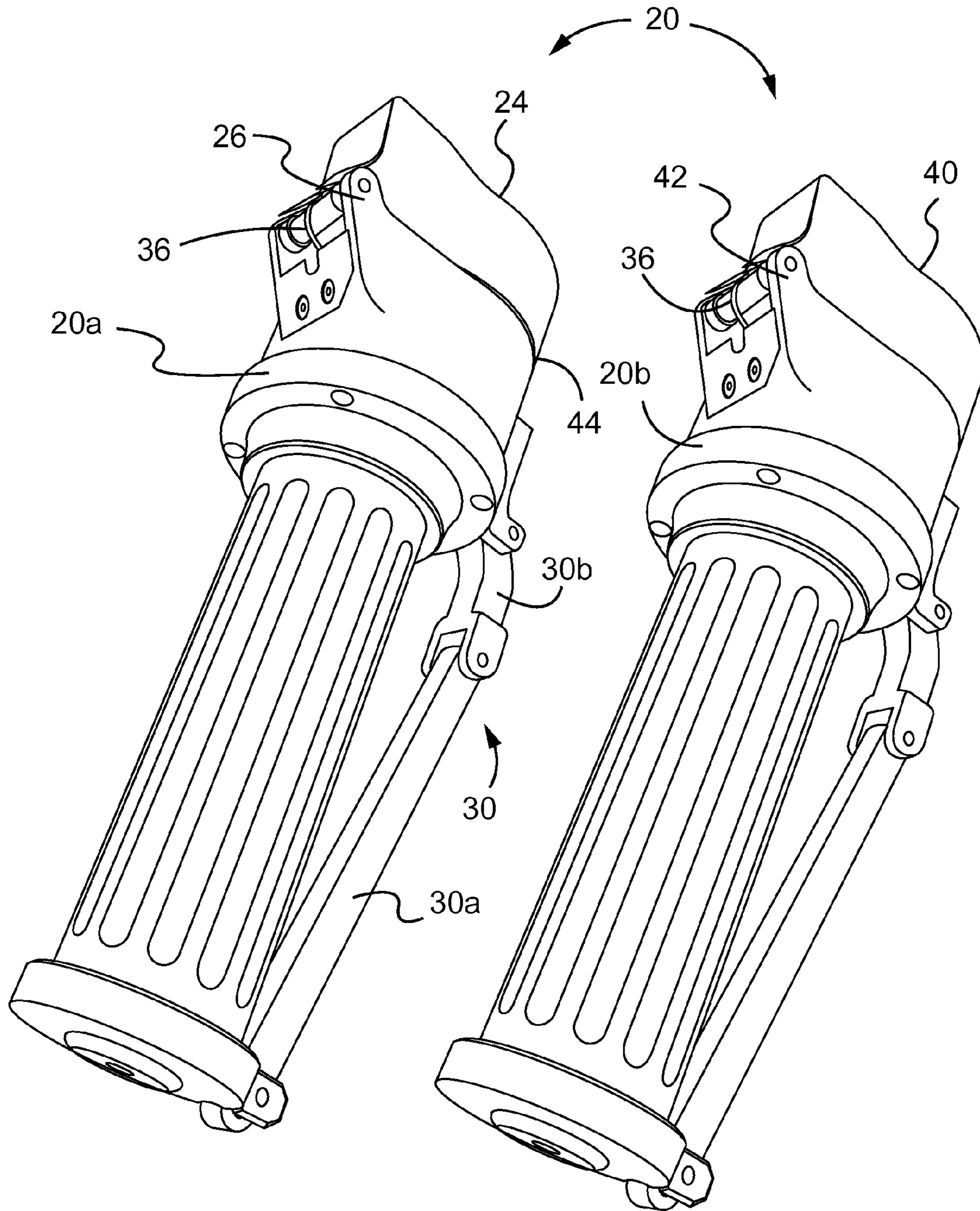

FIG.1A

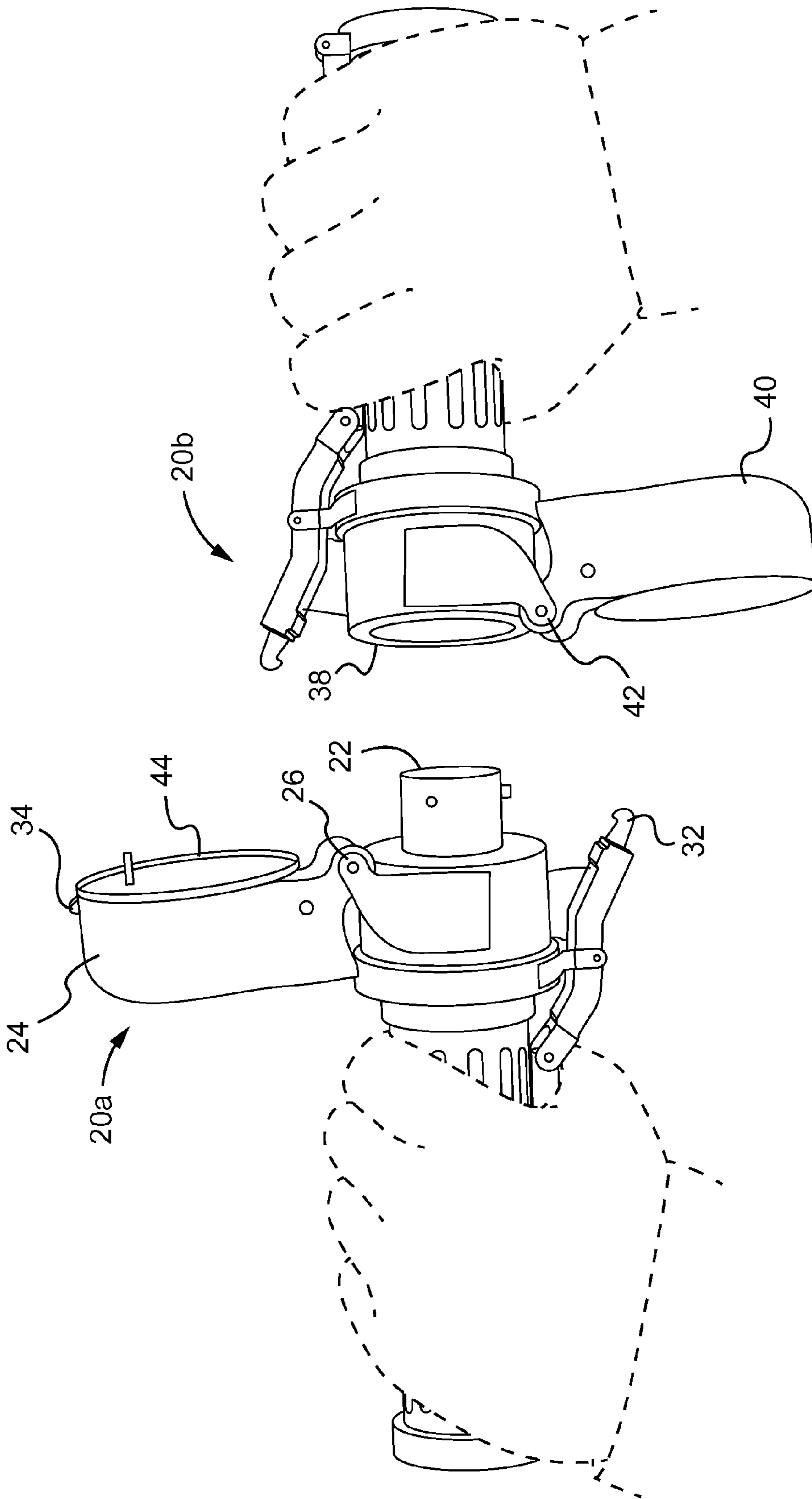

FIG.1B

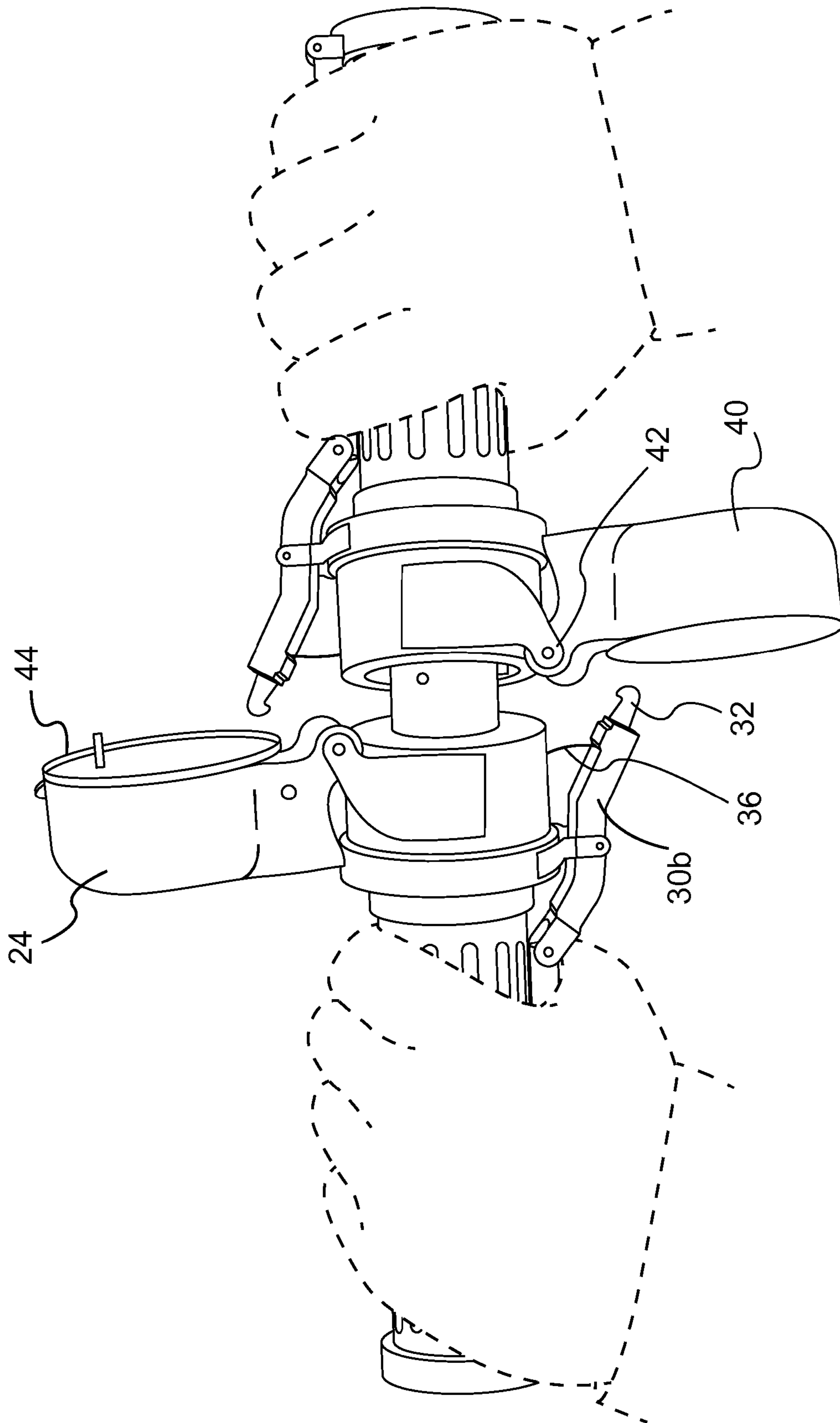

FIG.1C

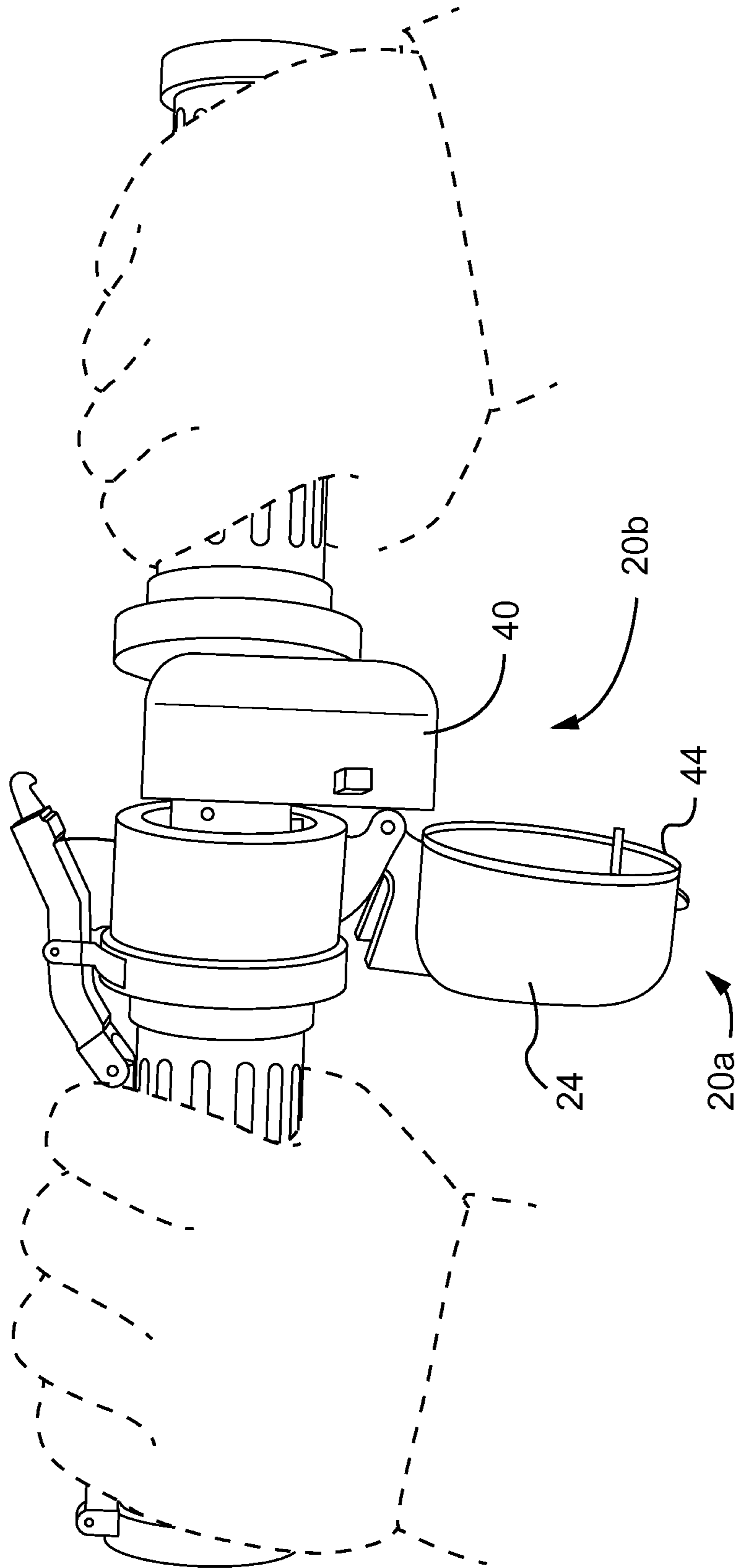

FIG.1D

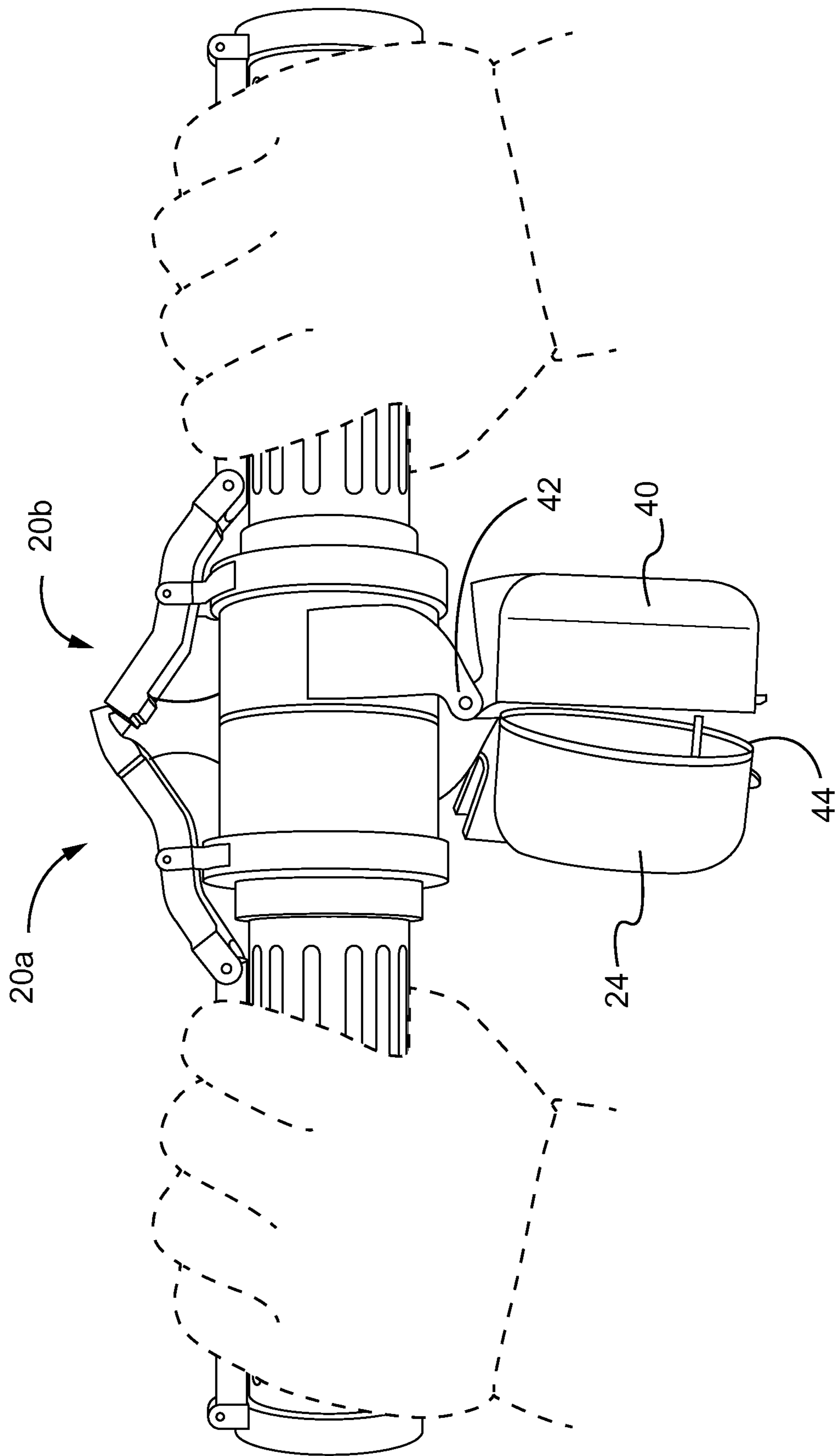

FIG.1E

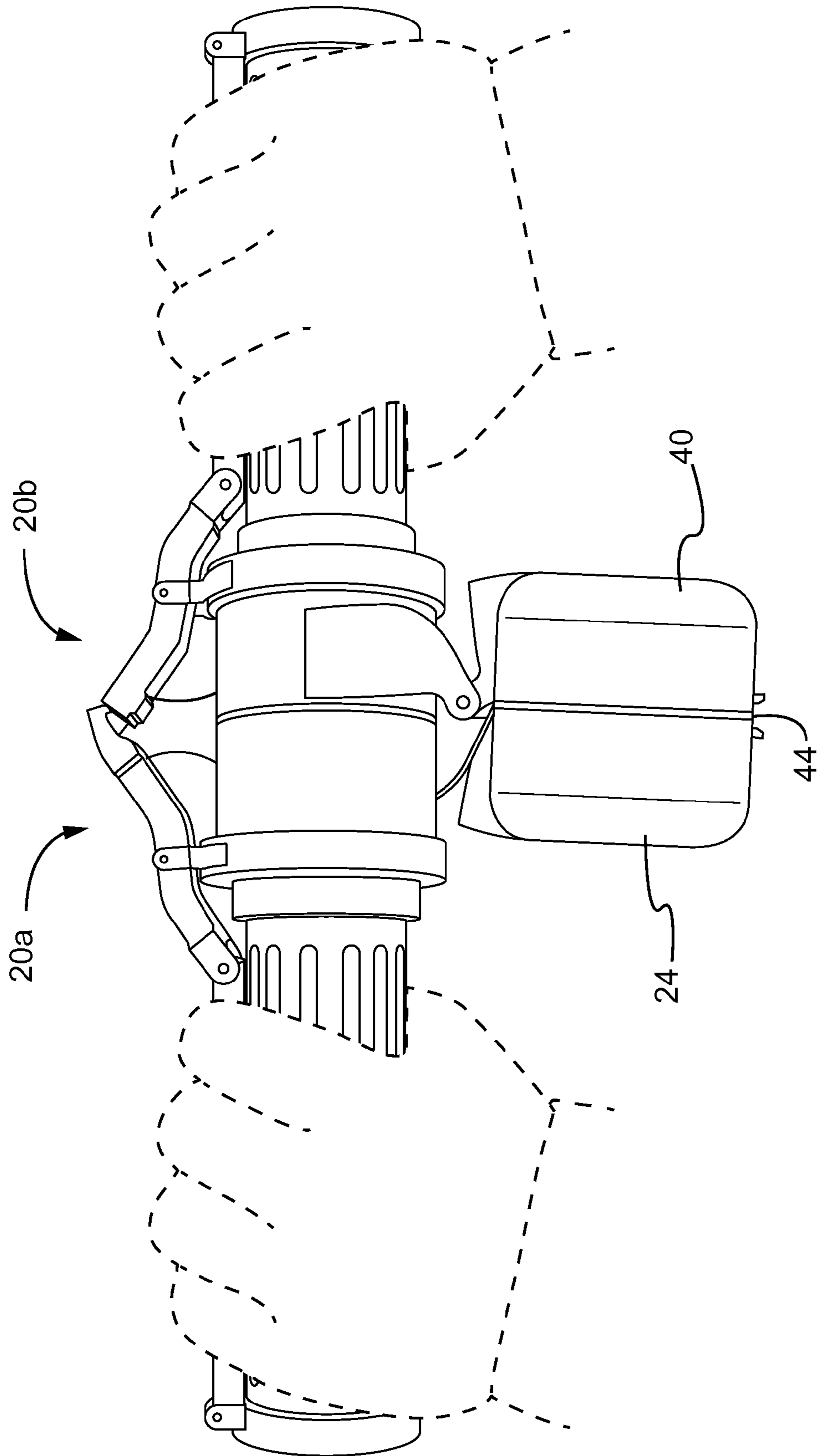

FIG. 1F



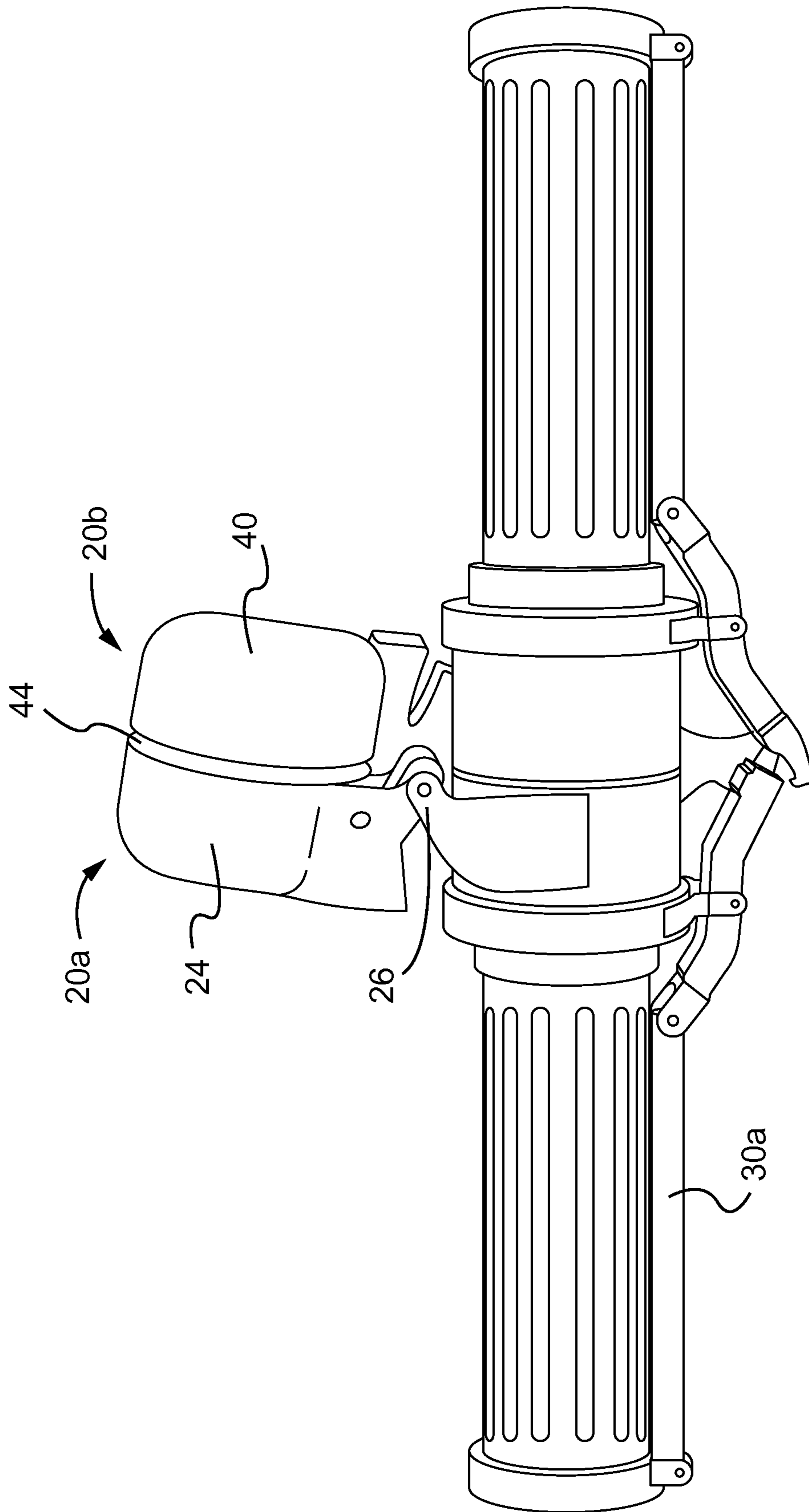

FIG.1G

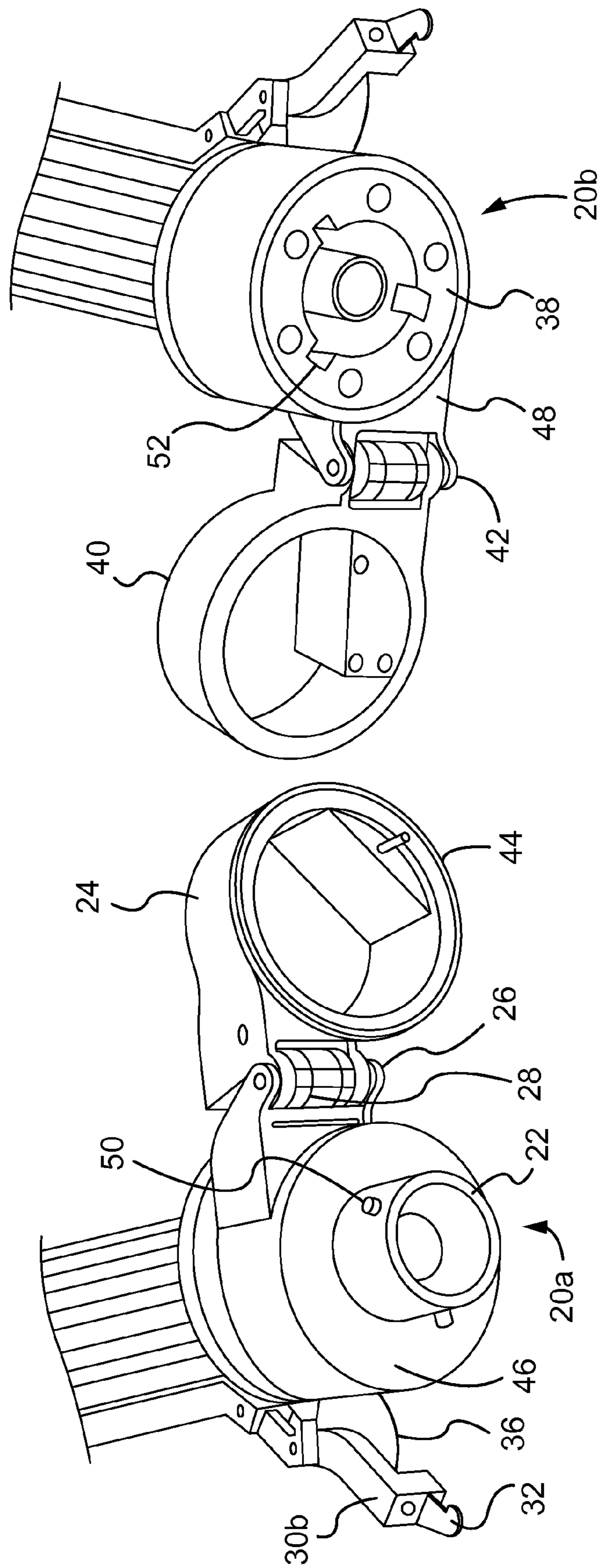

FIG. 1H

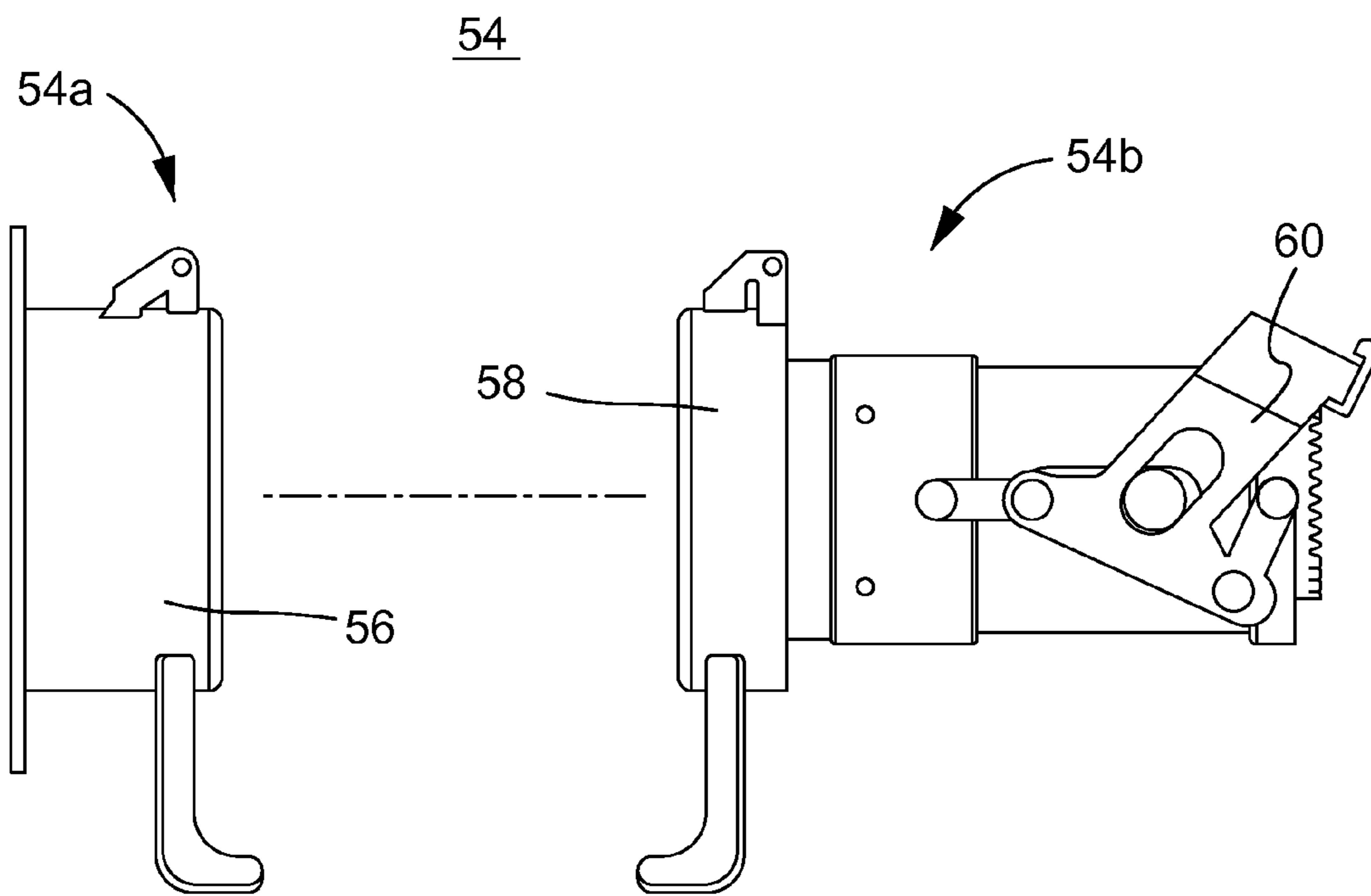

FIG.2A

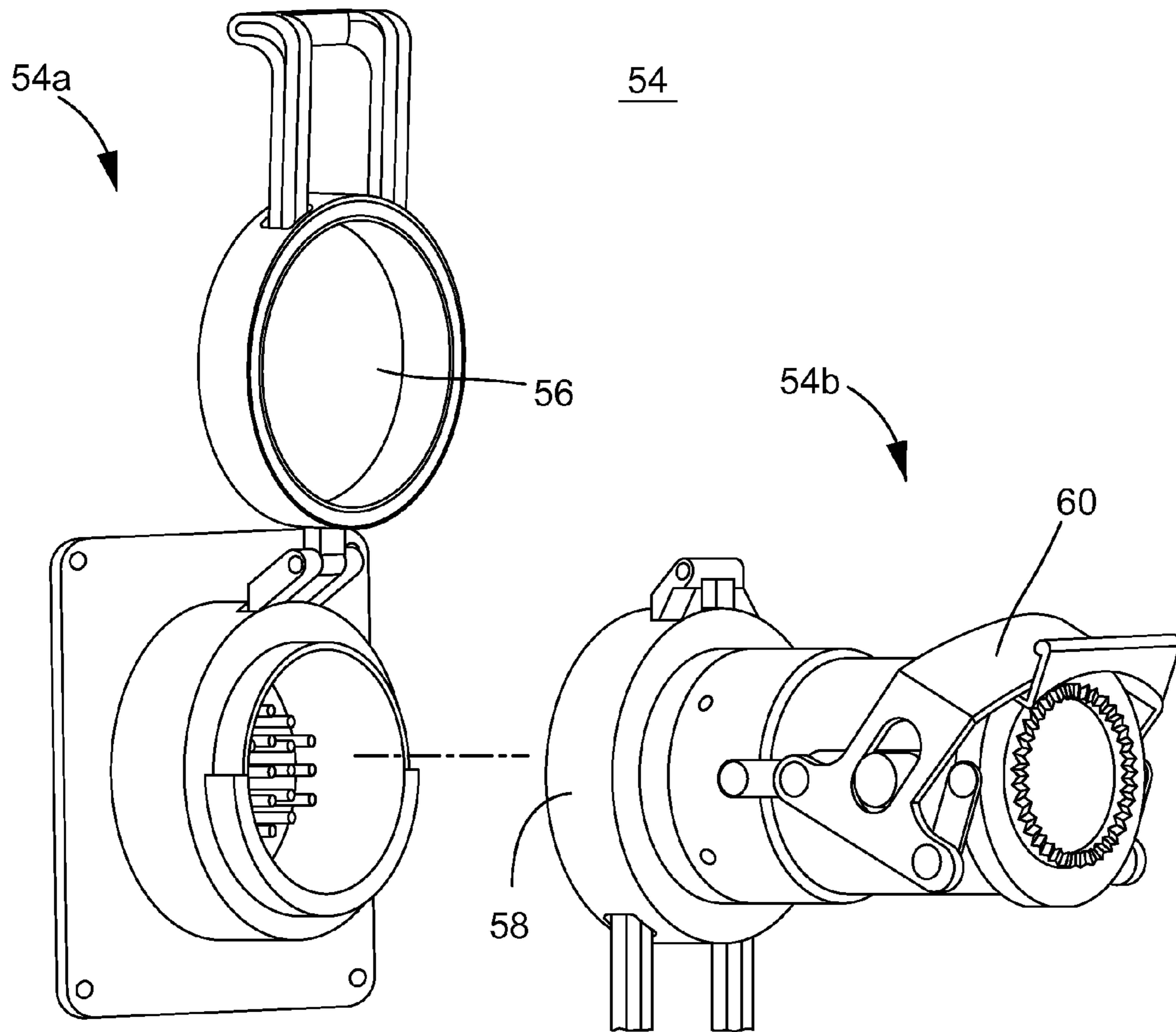

FIG.2B

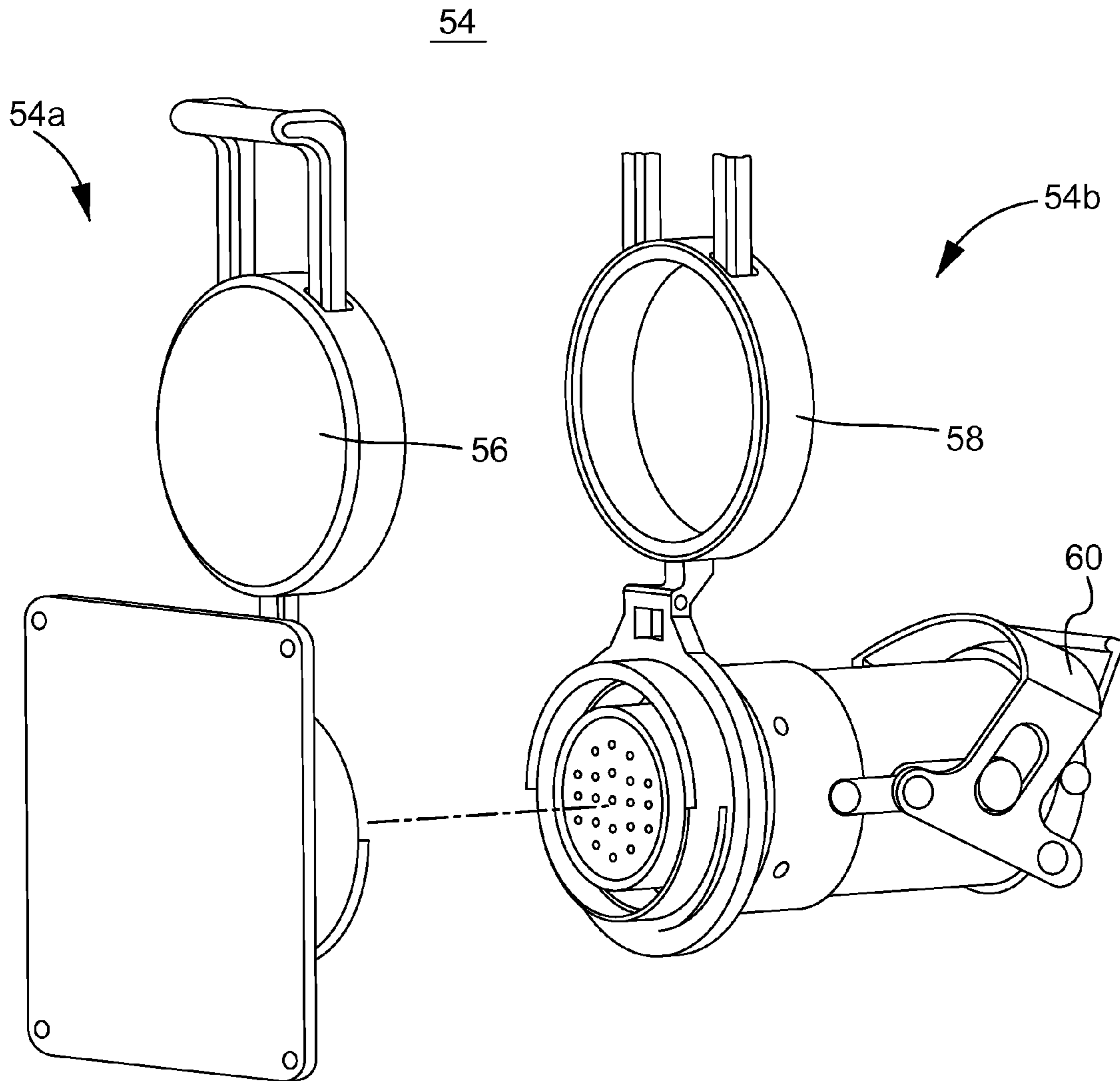

FIG.2C

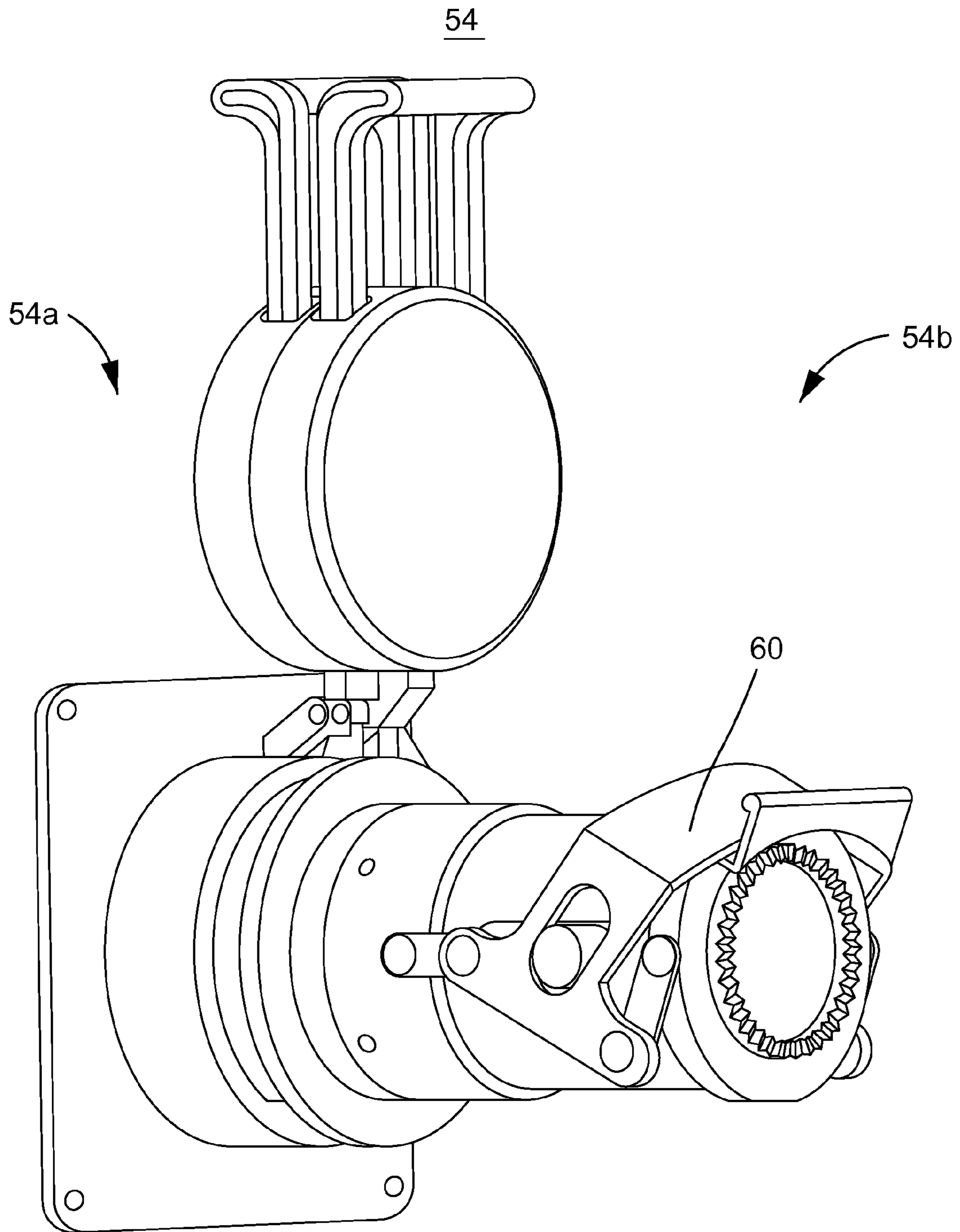

FIG.2D

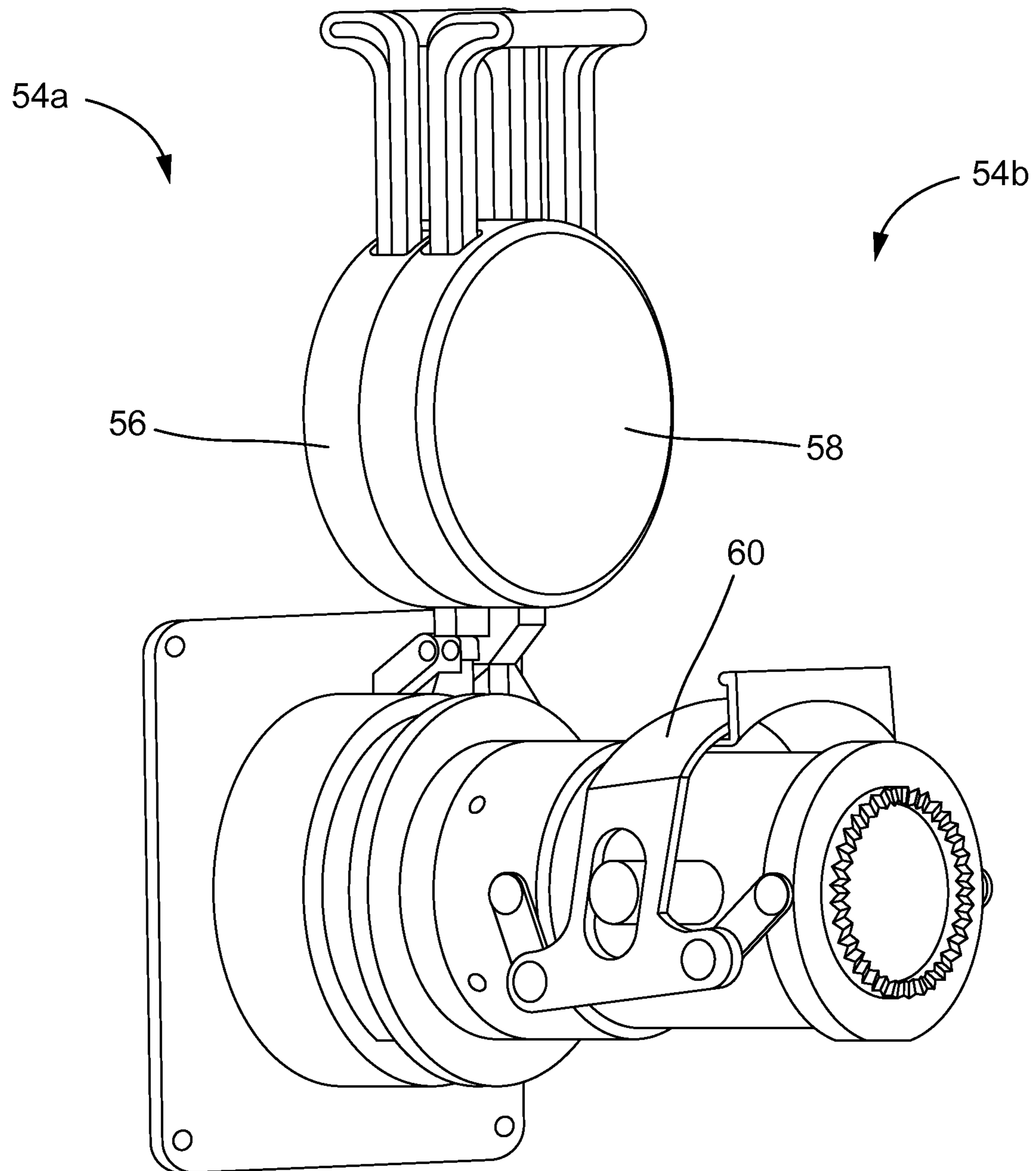
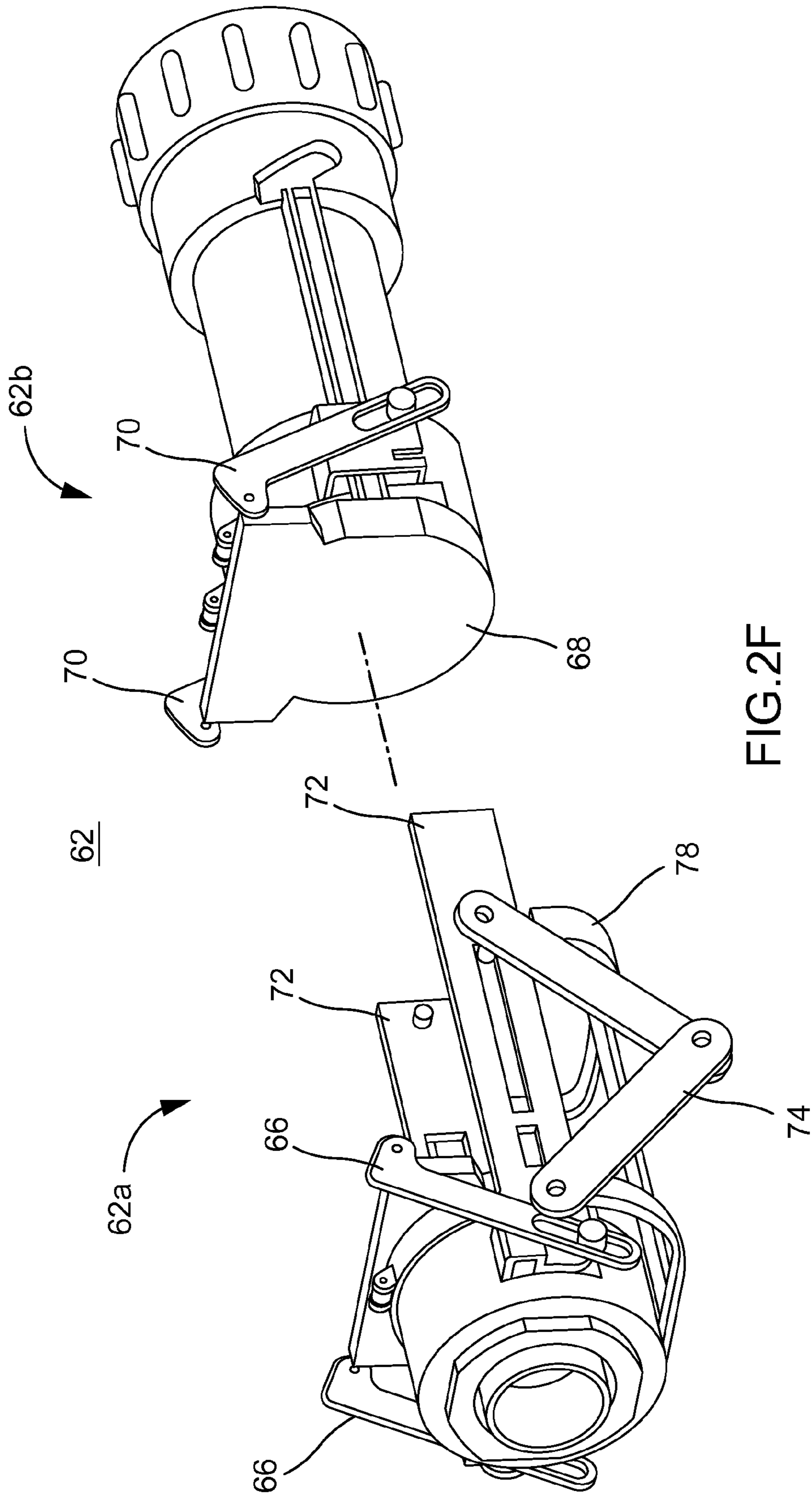

FIG.2E





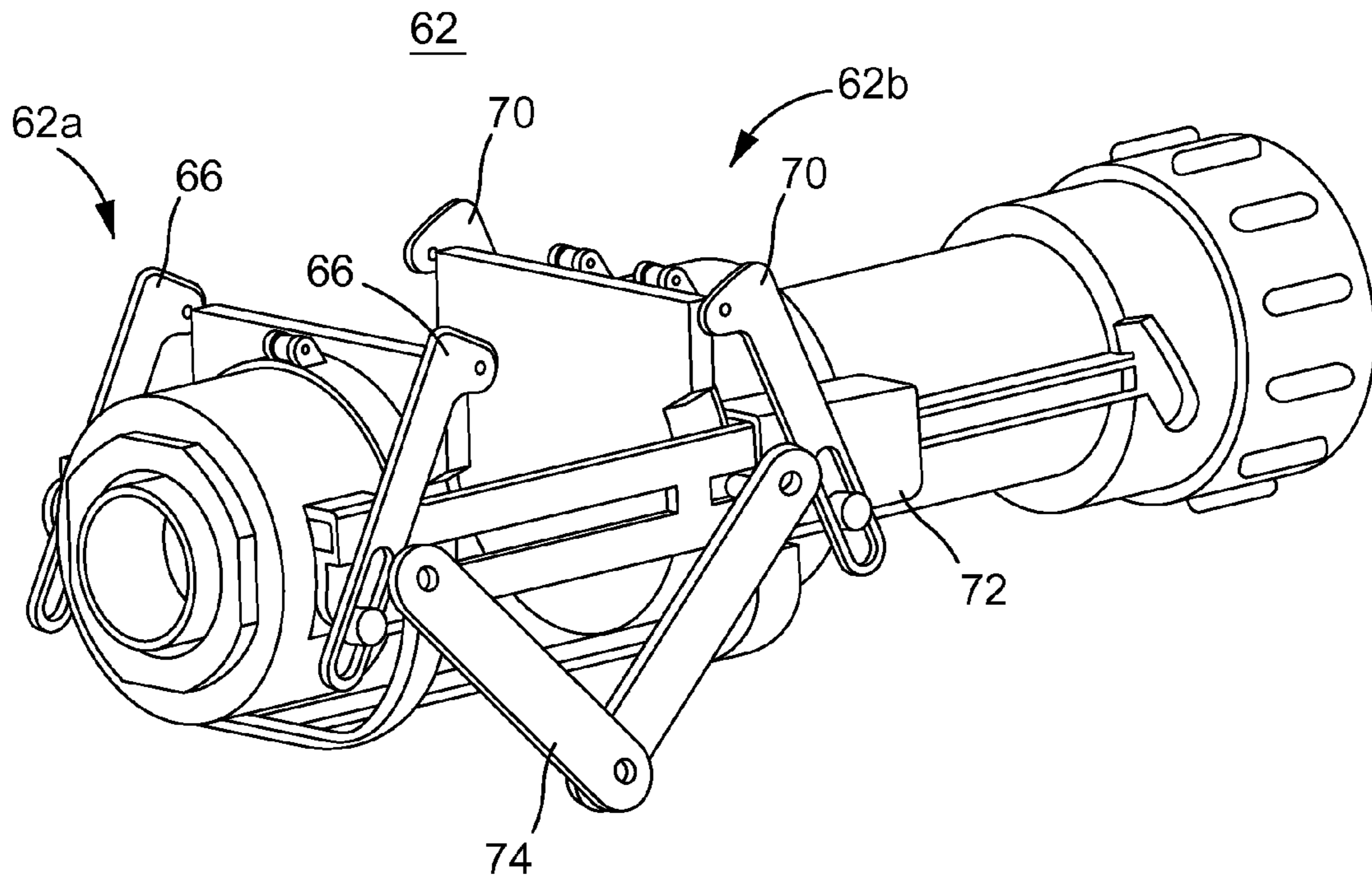

FIG.2G

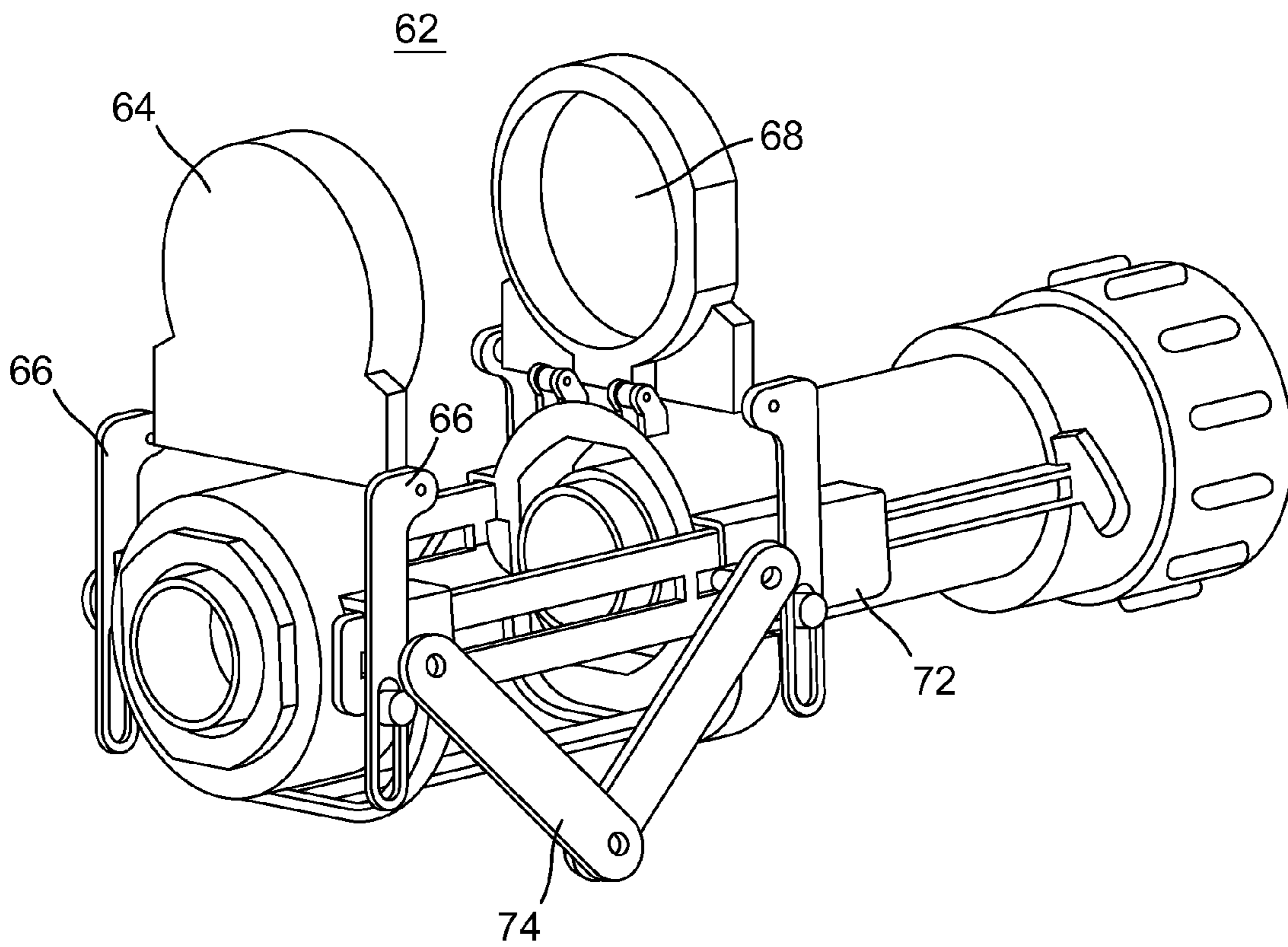

FIG.2H

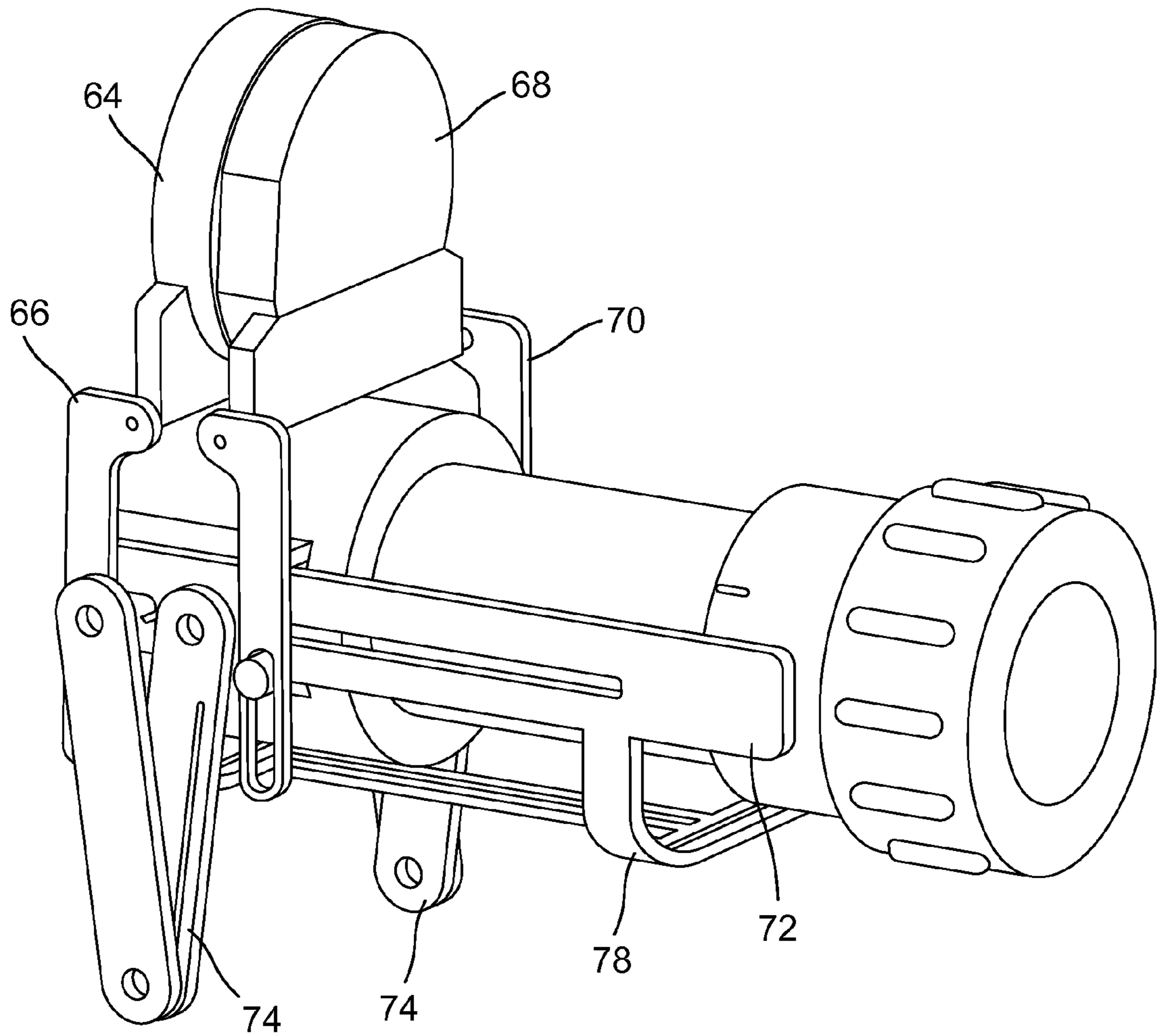

FIG. 21

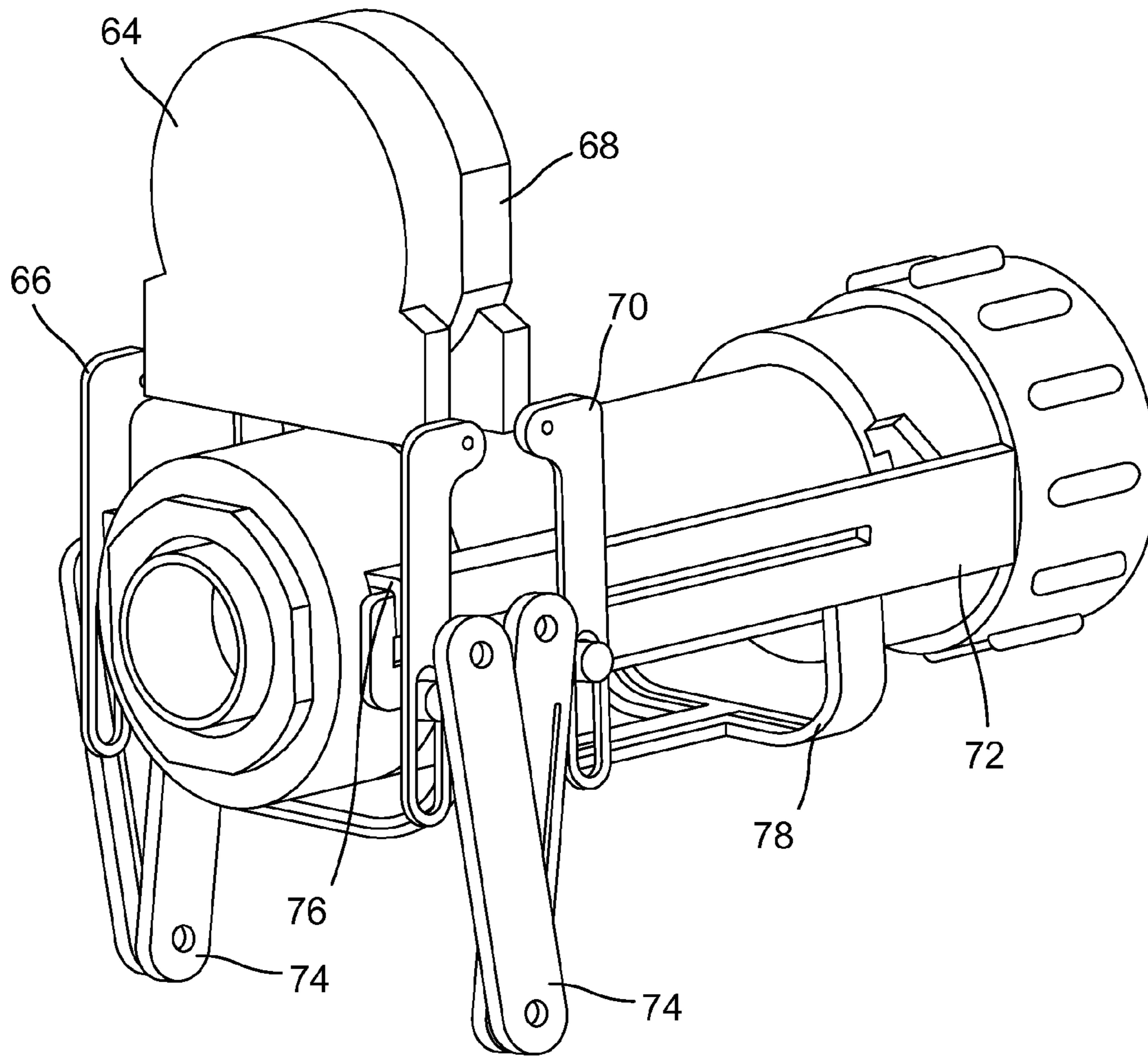

FIG.2J

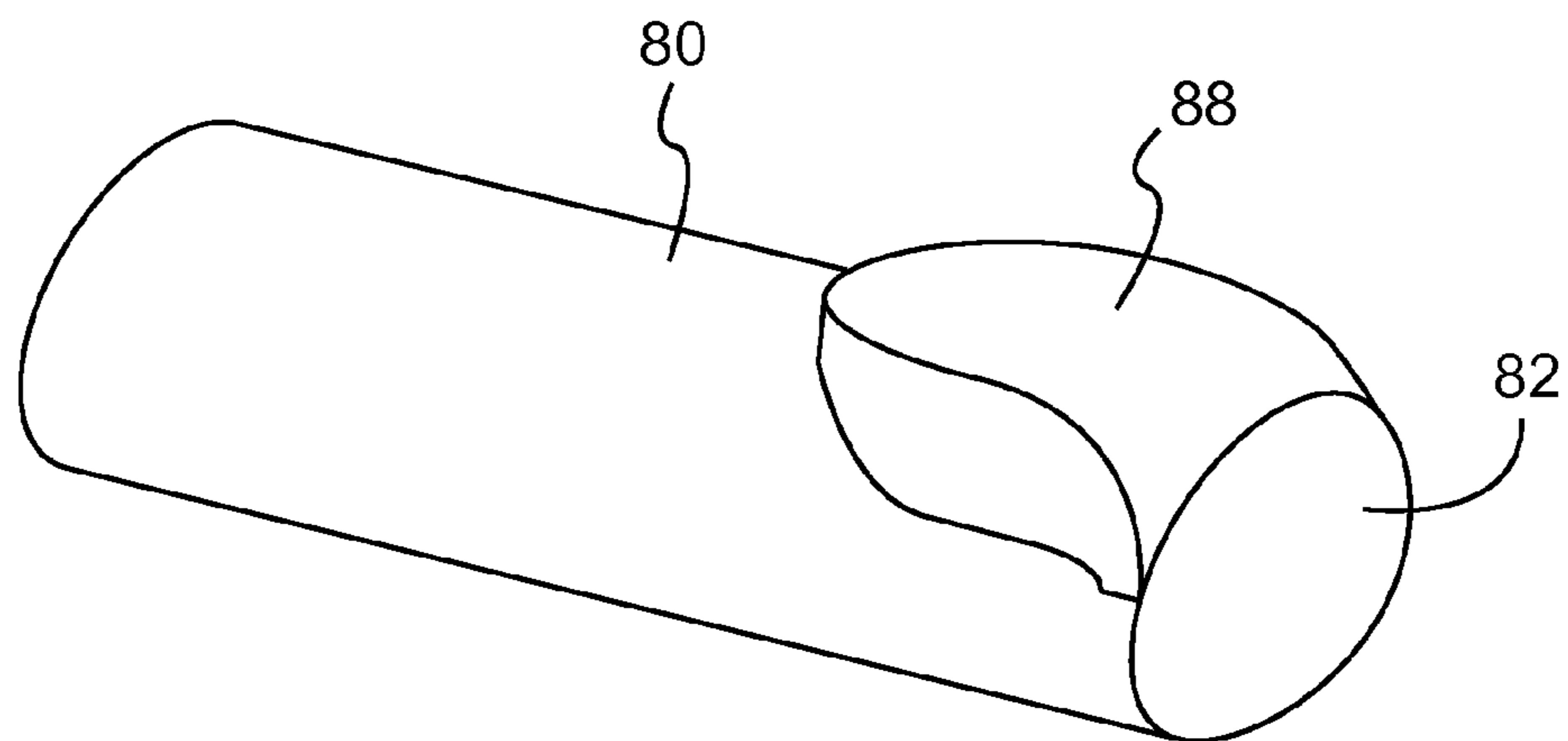

FIG.3A

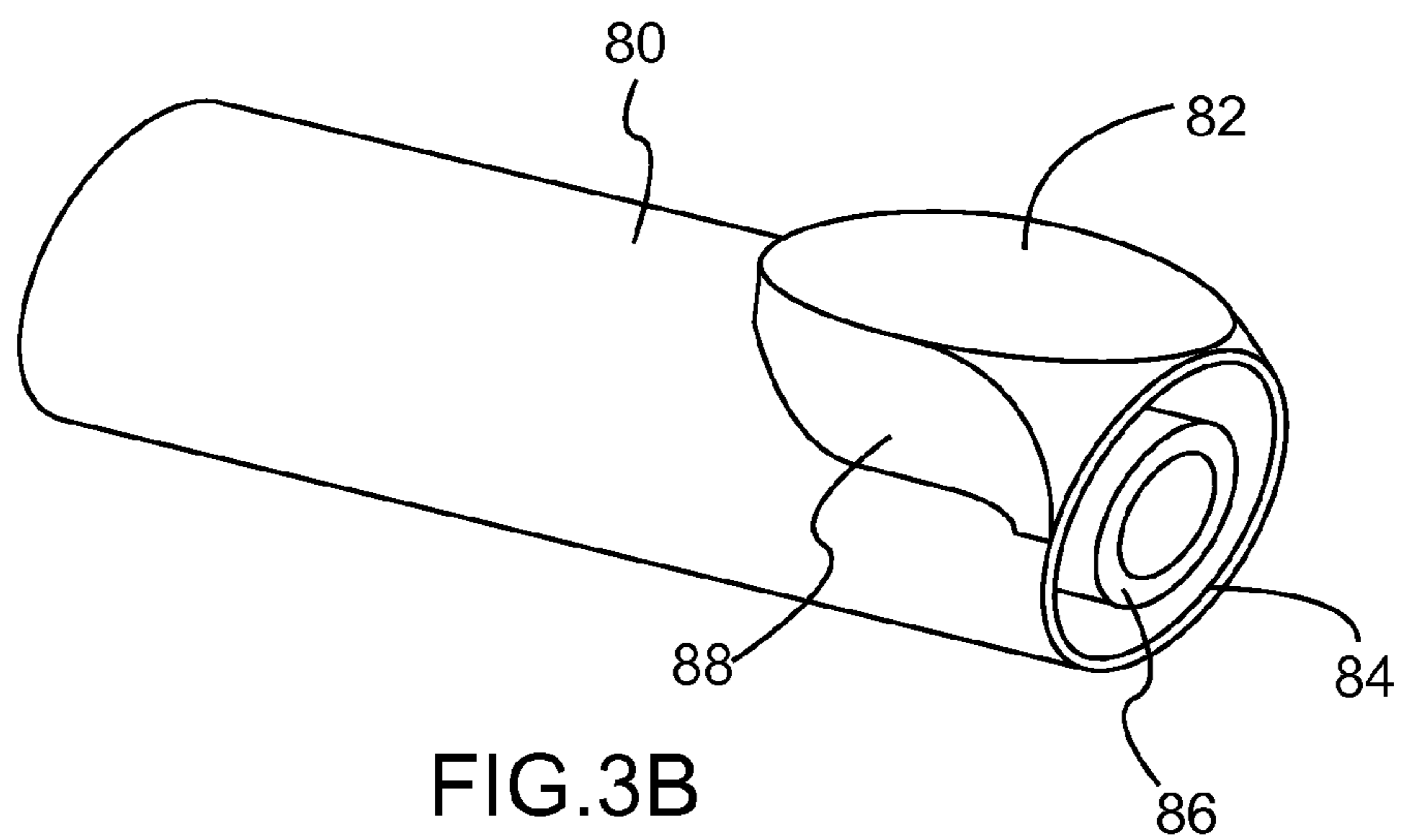

FIG.3B

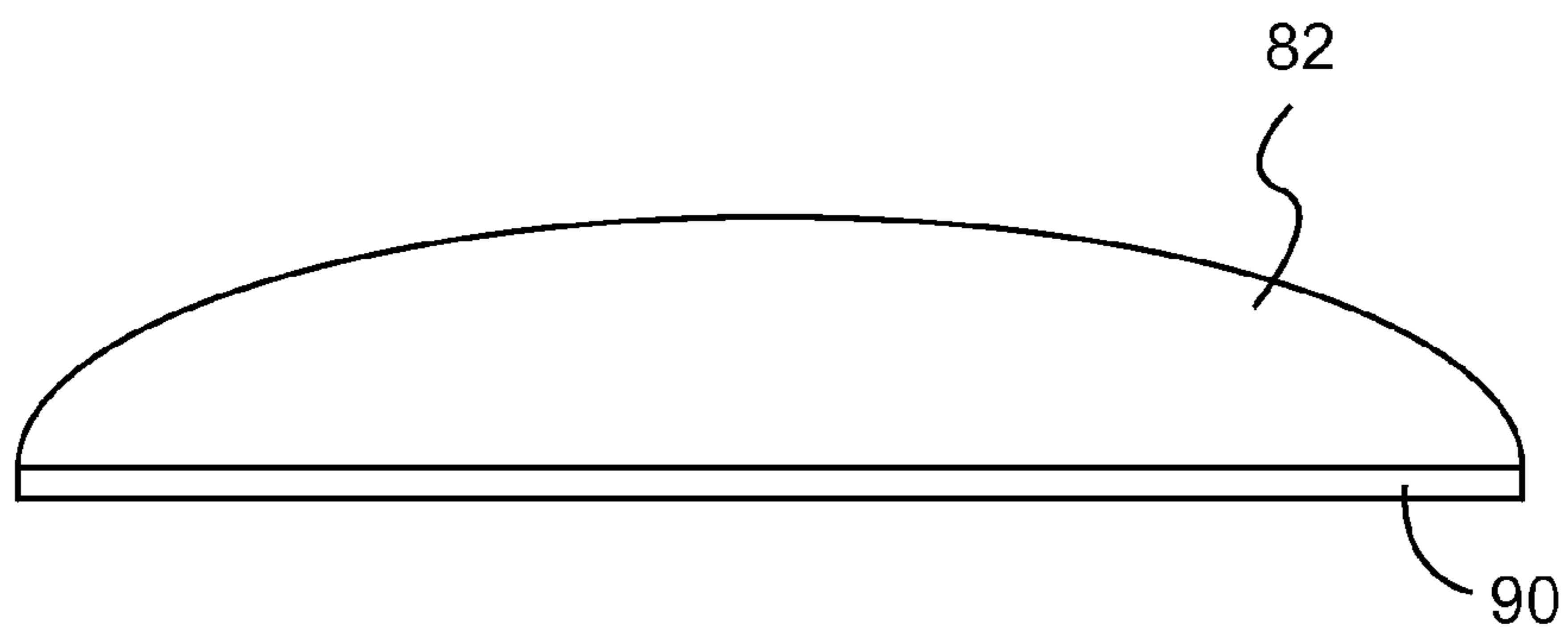

FIG.3C

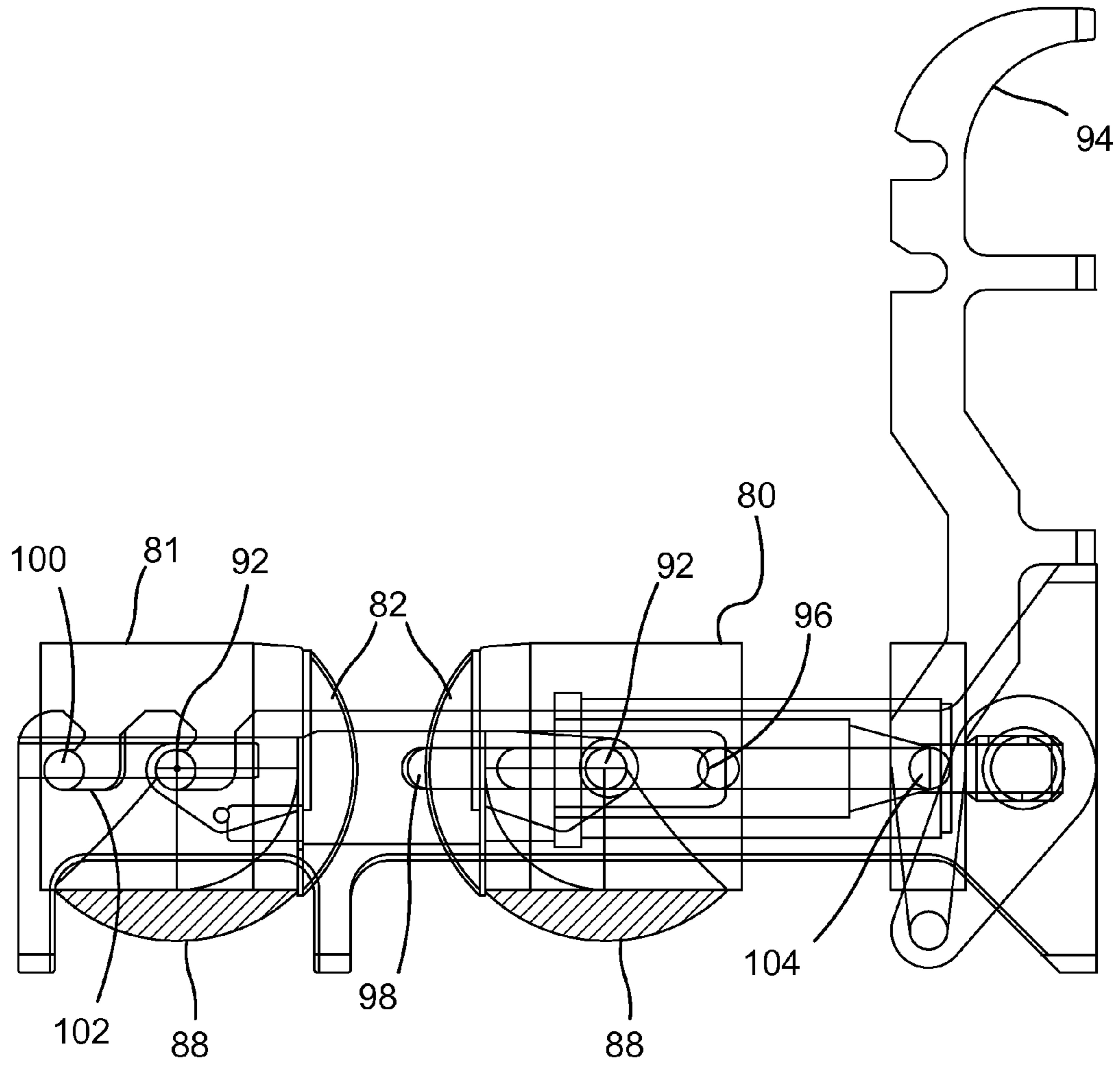

FIG.3D

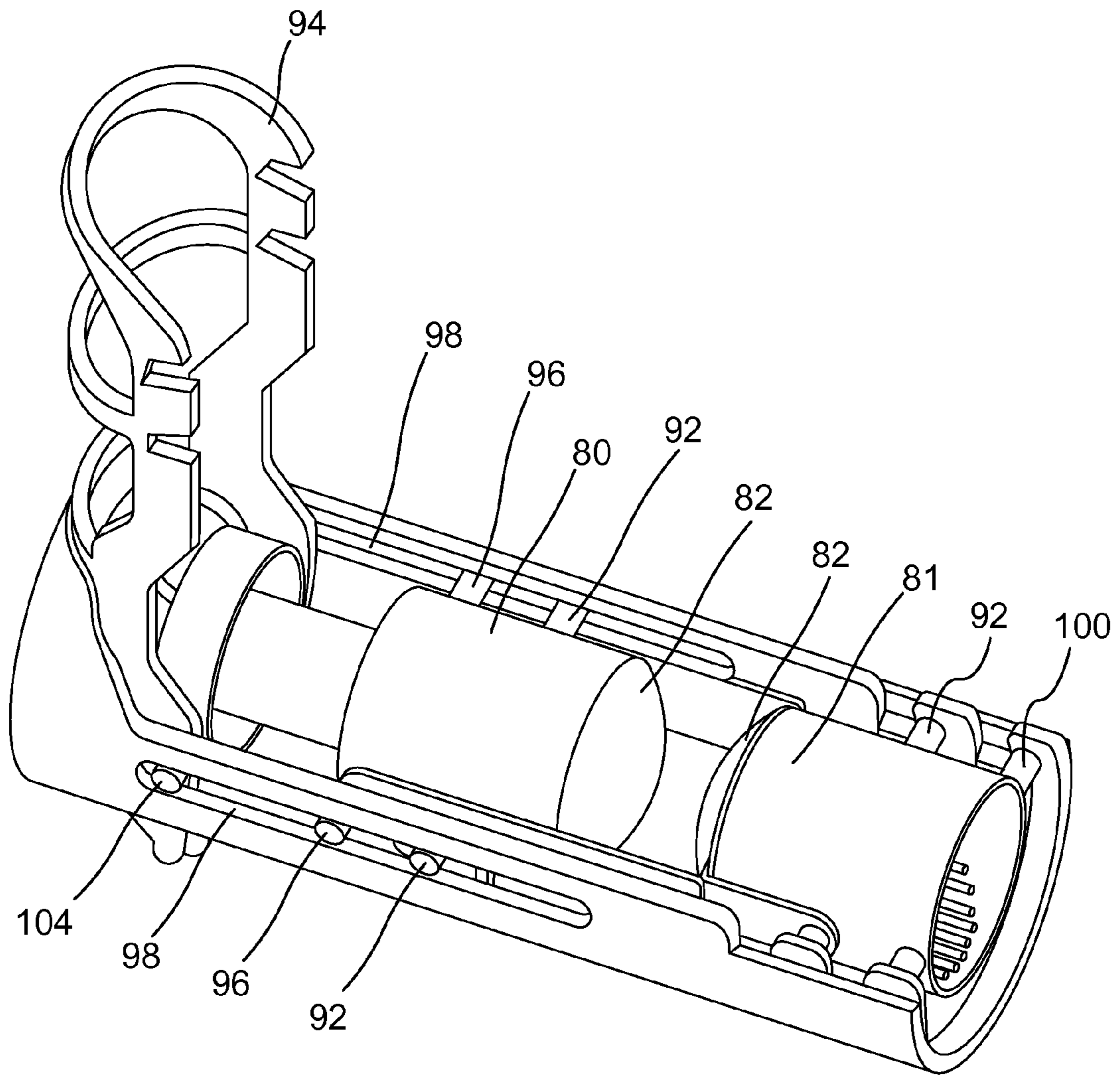

FIG.3E

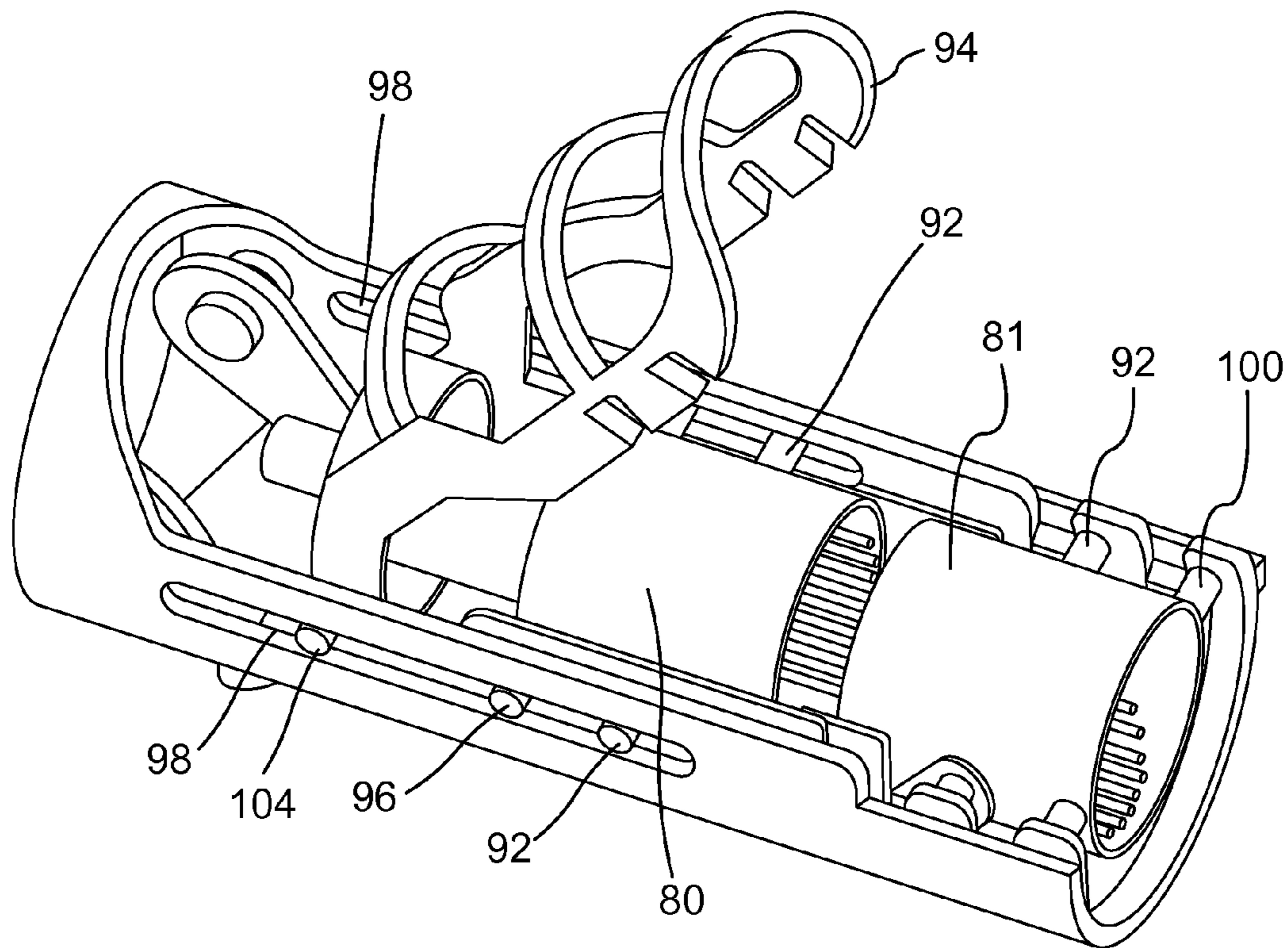

FIG.3F

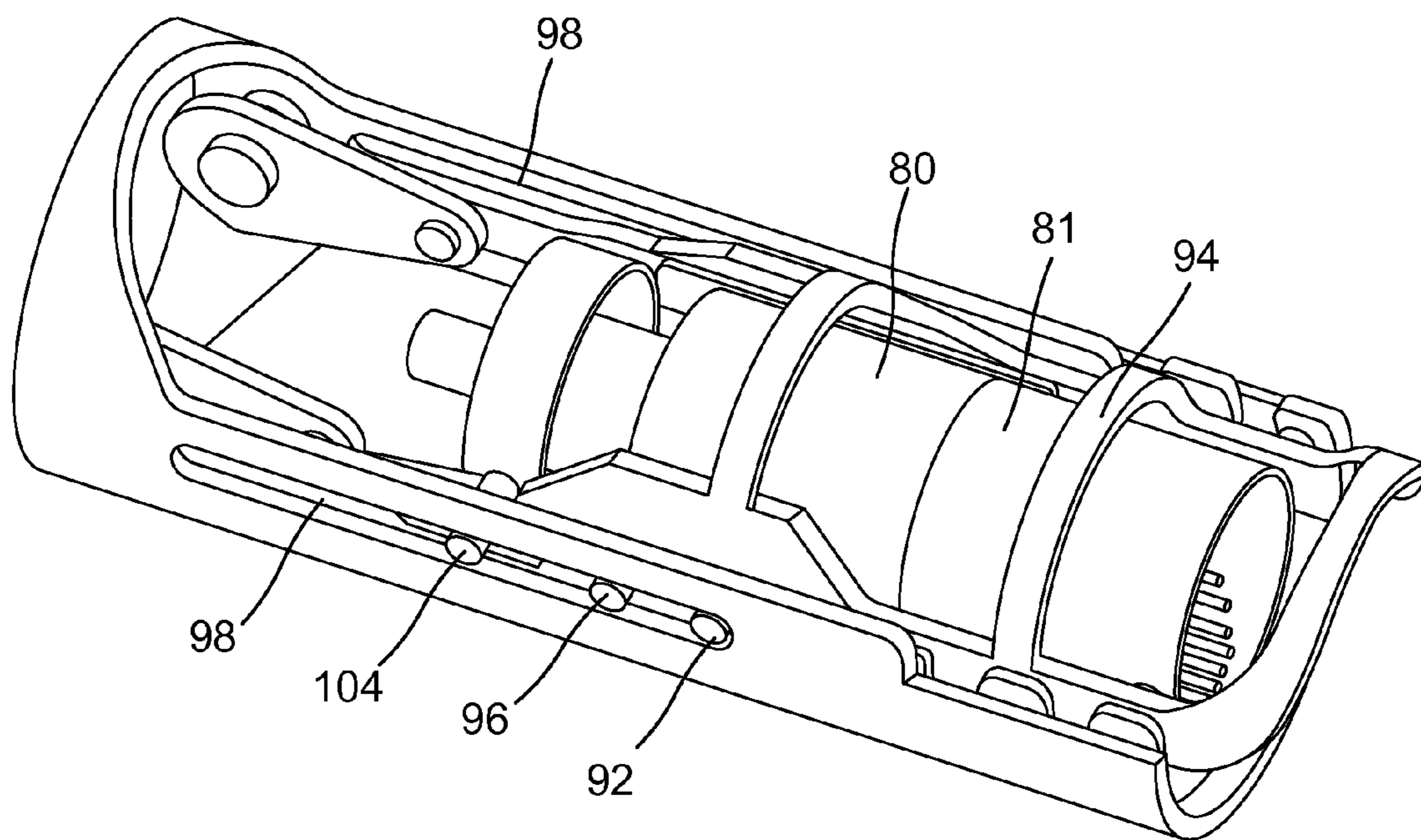

FIG.3G

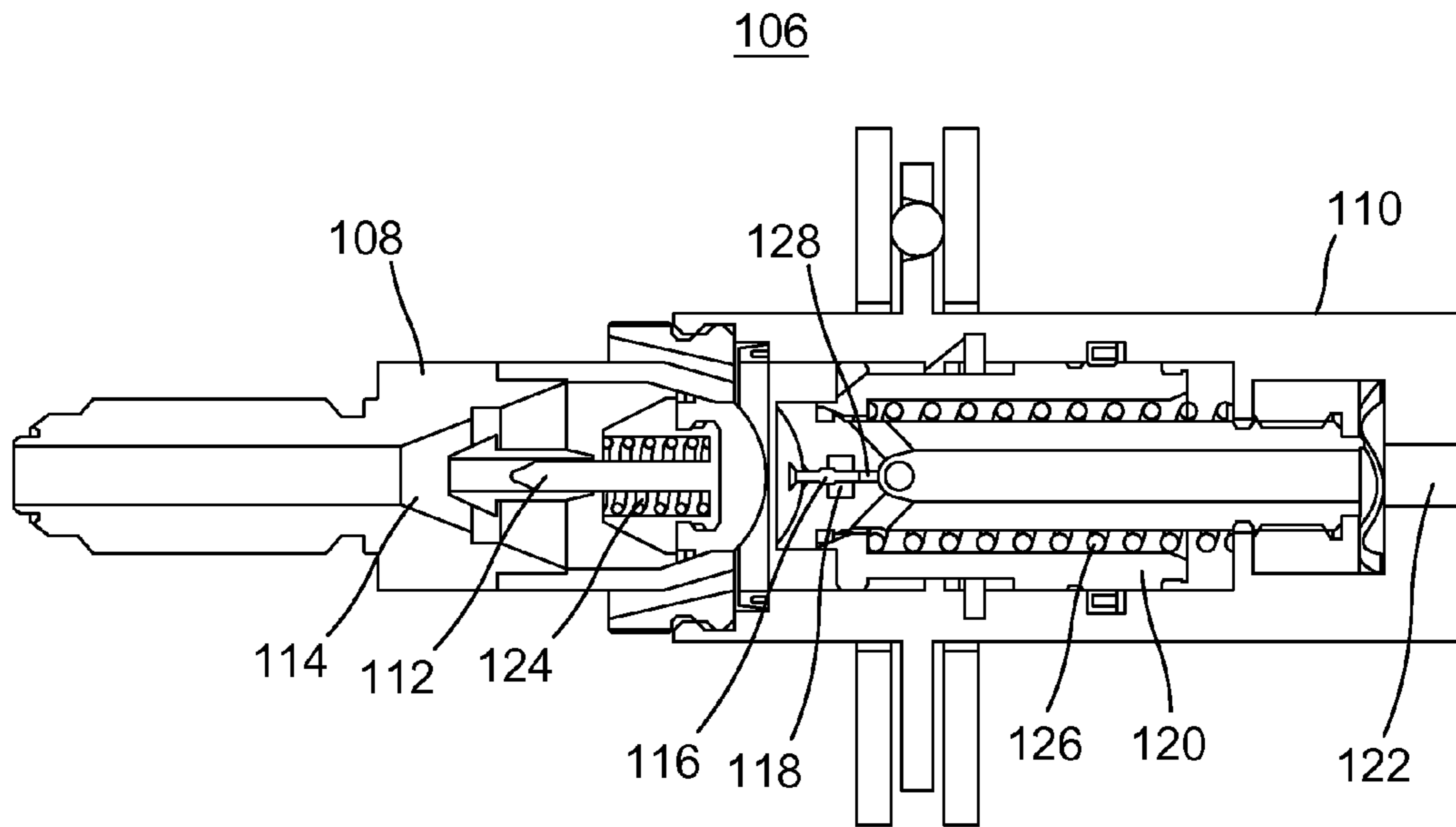

FIG.4A

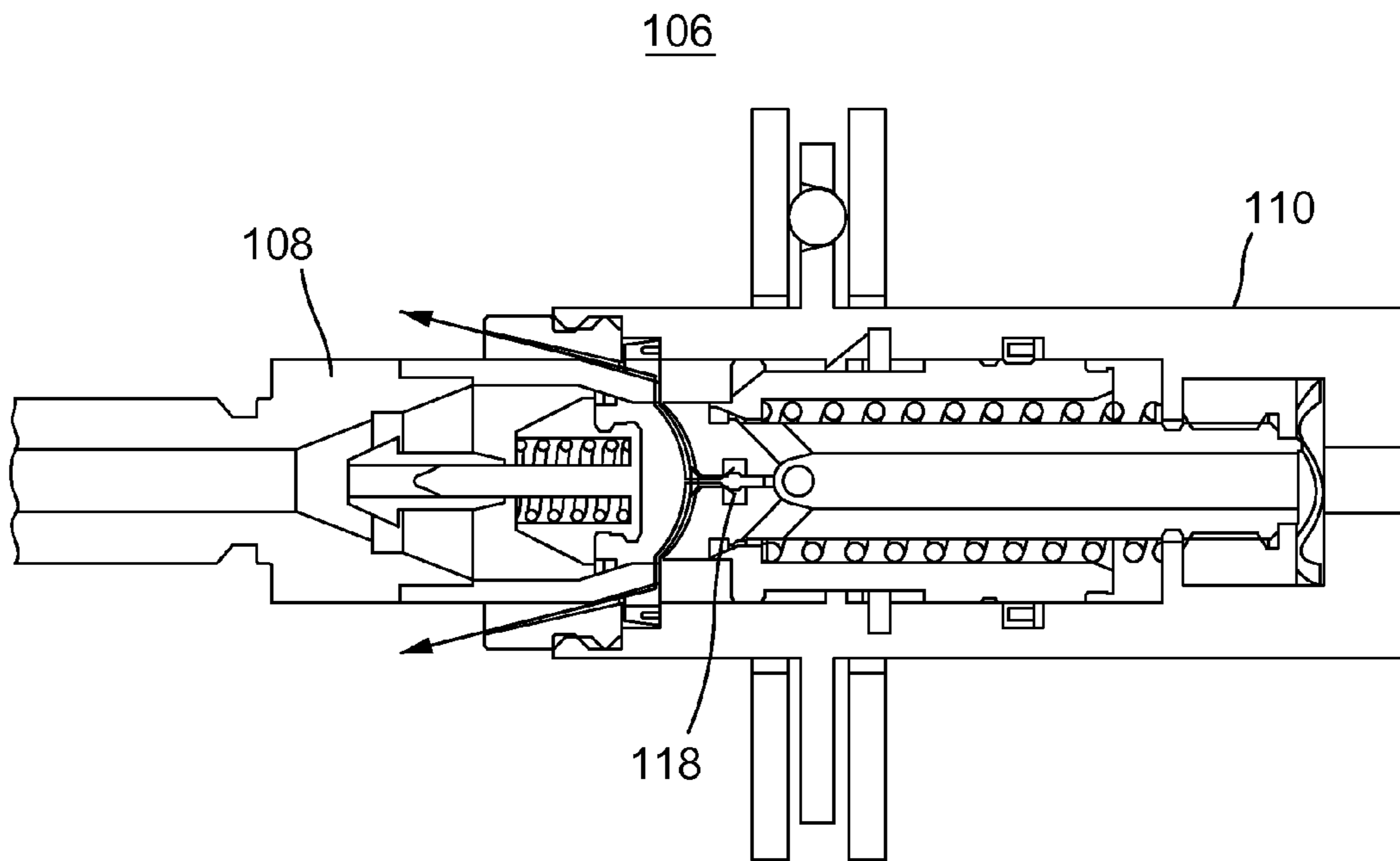

FIG.4B



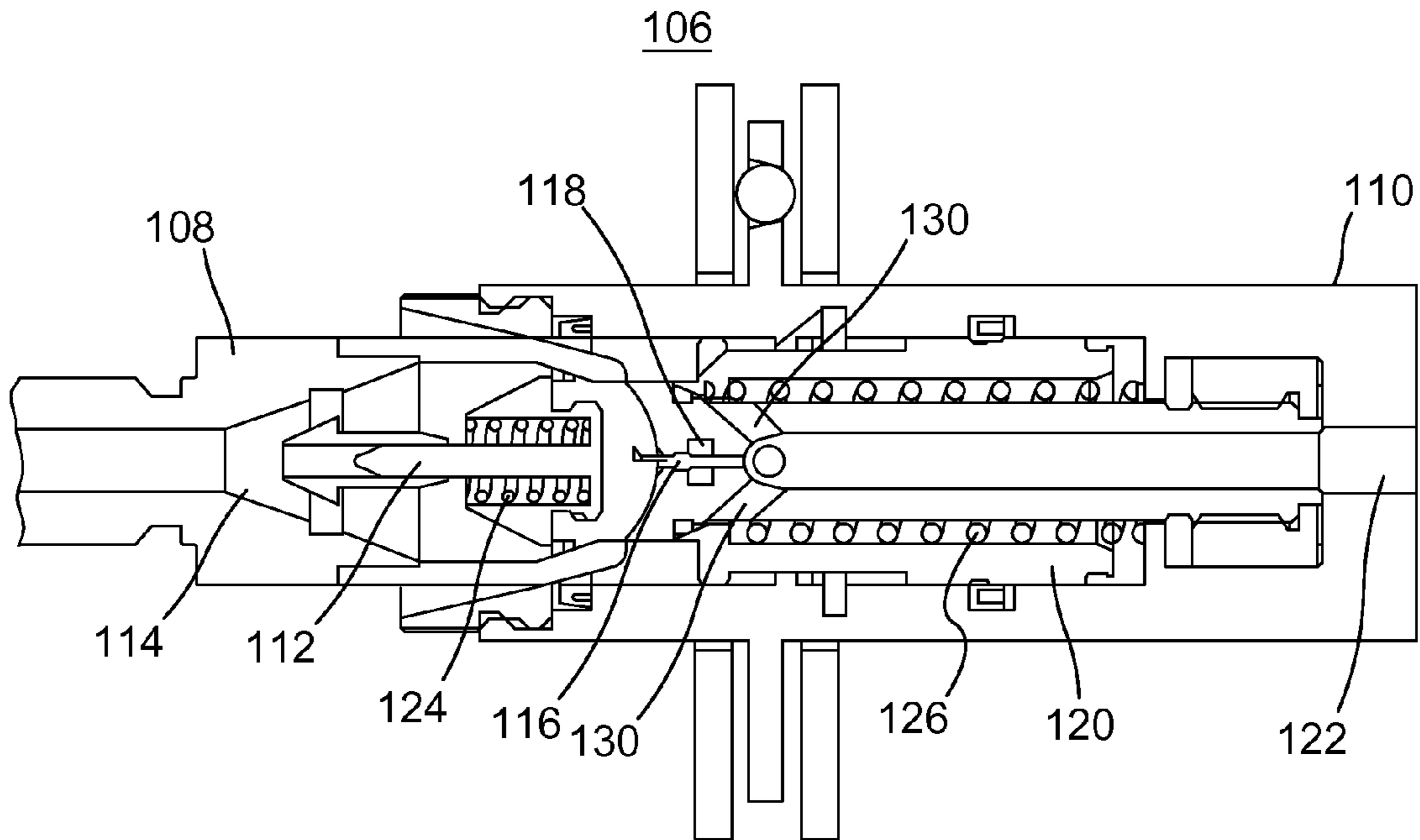

FIG. 4C

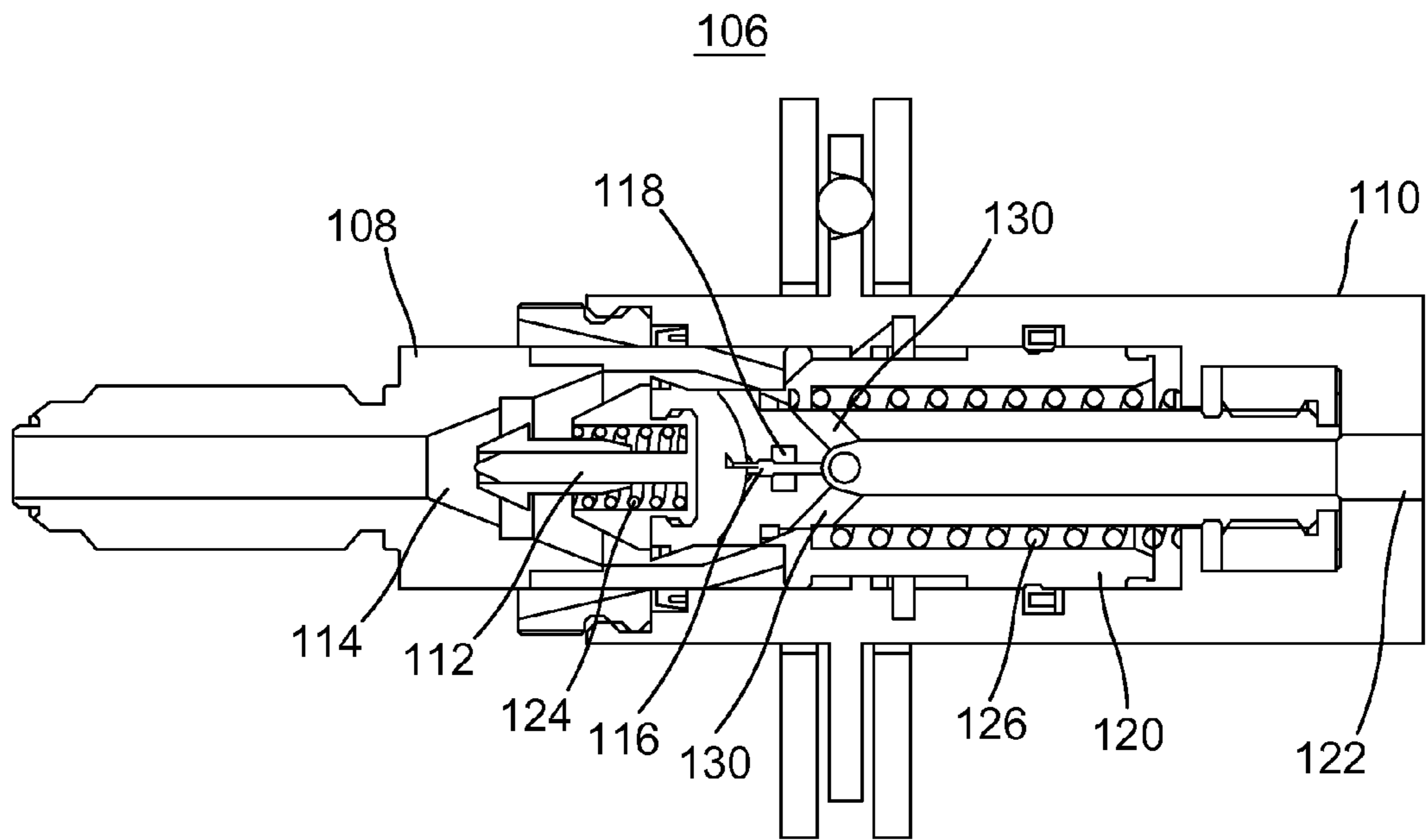

FIG. 4D

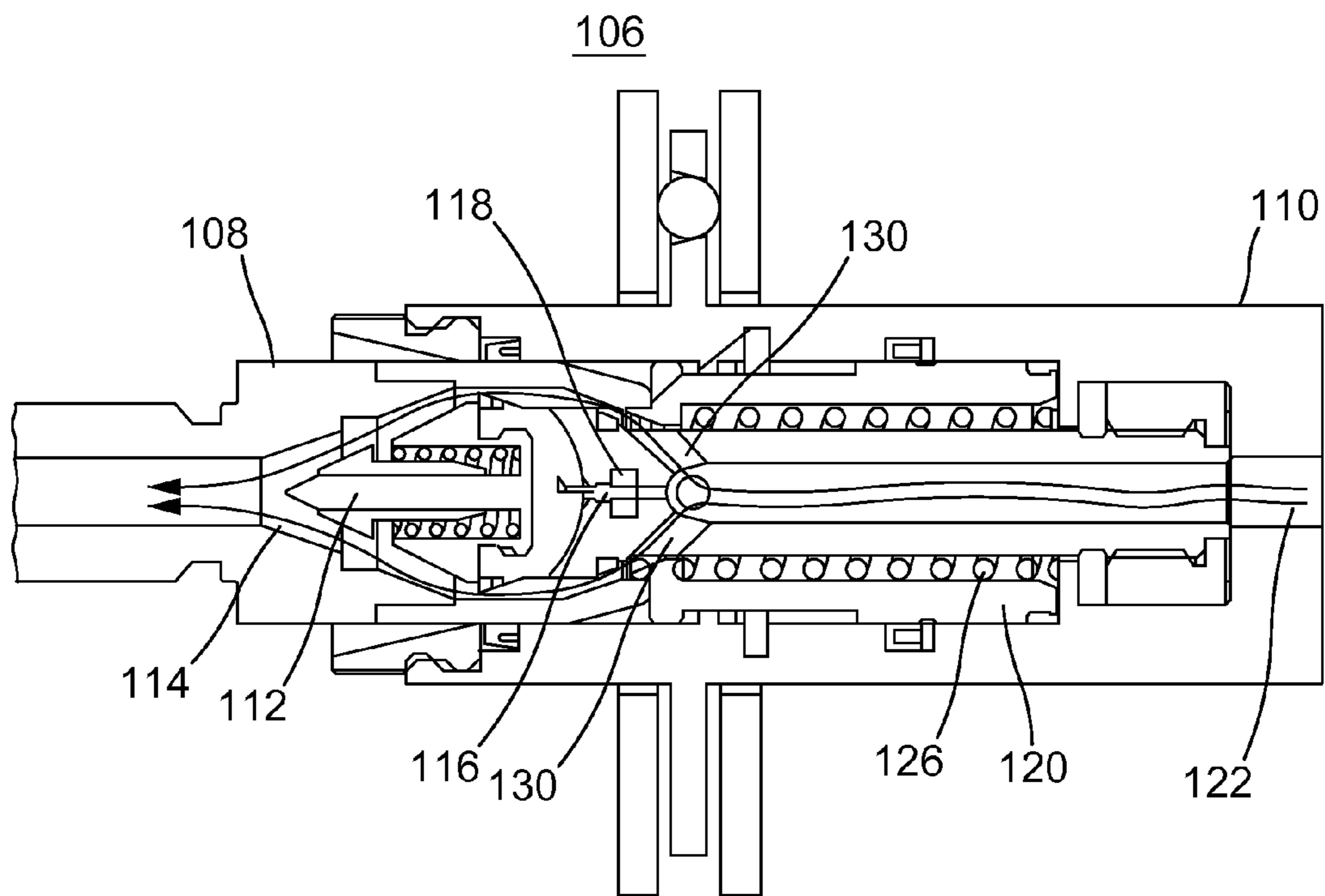

FIG. 4E

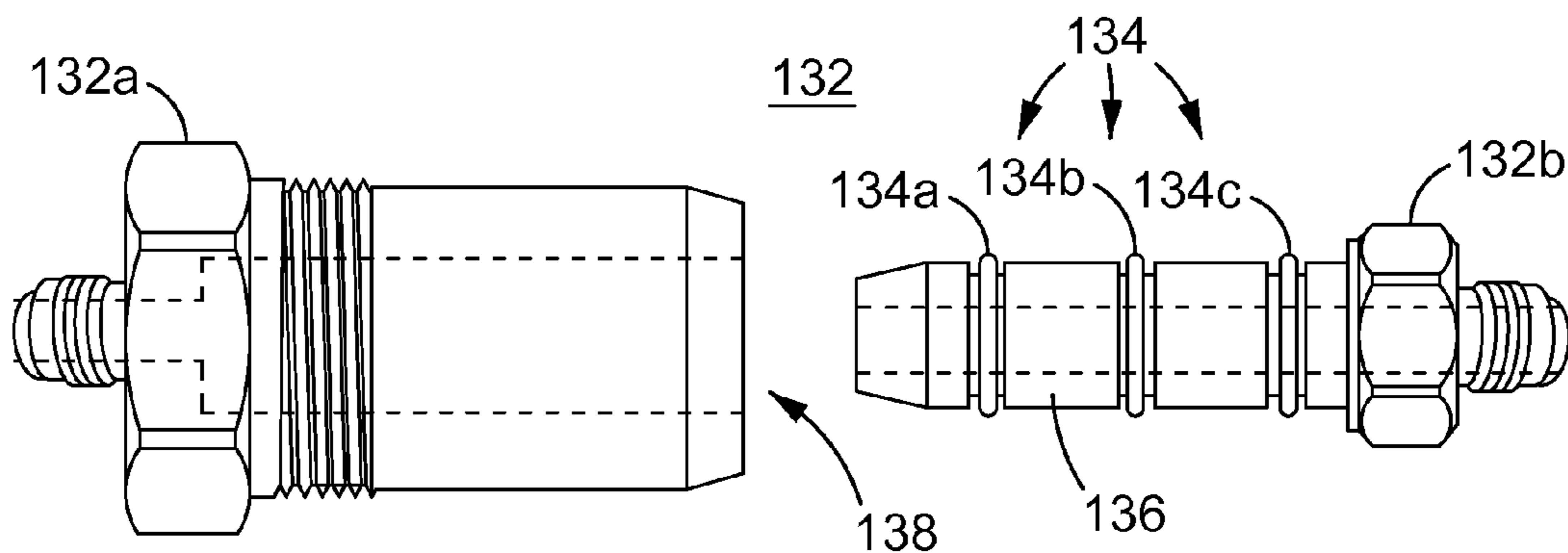

FIG. 5A

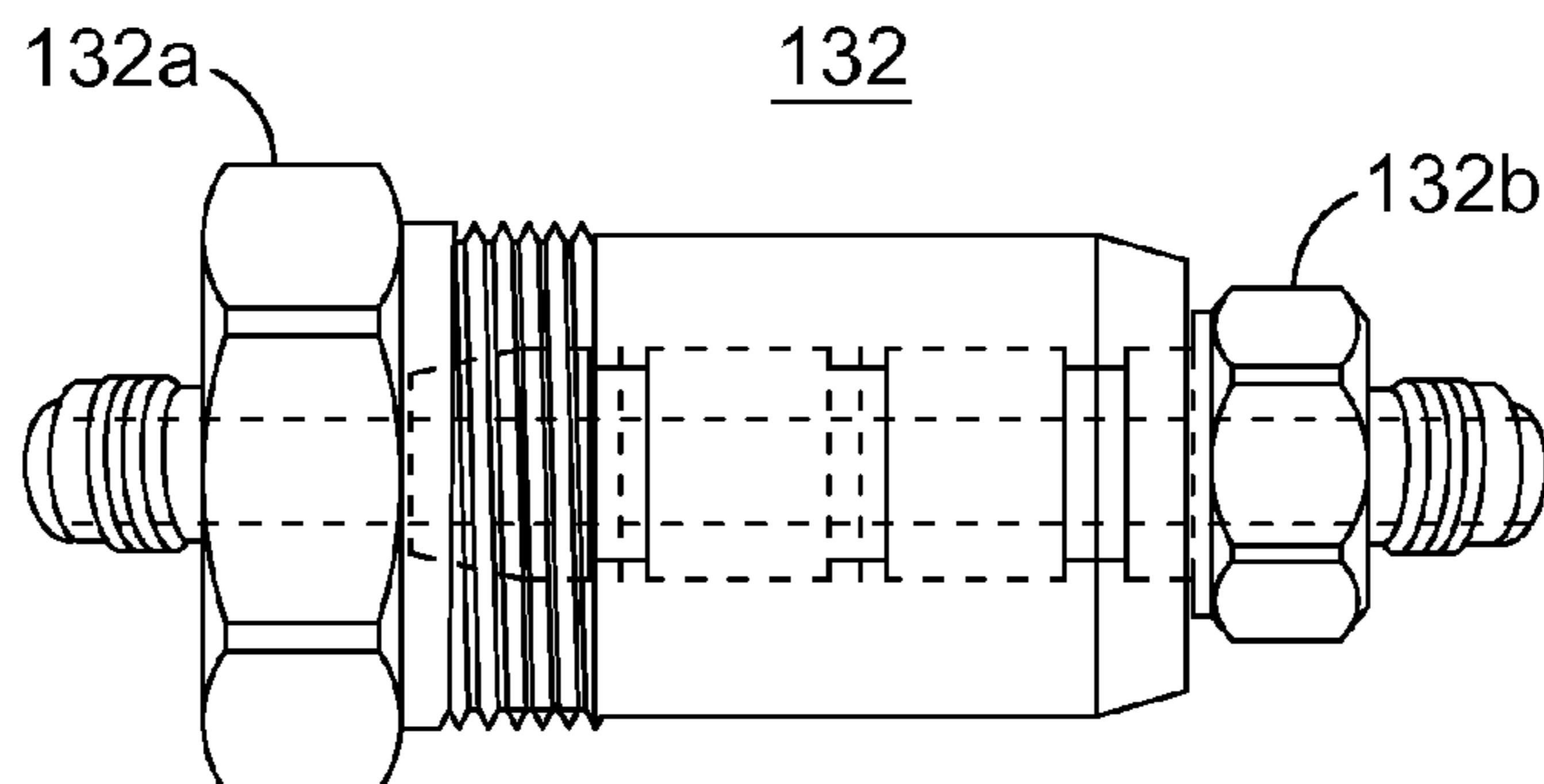

FIG. 5B

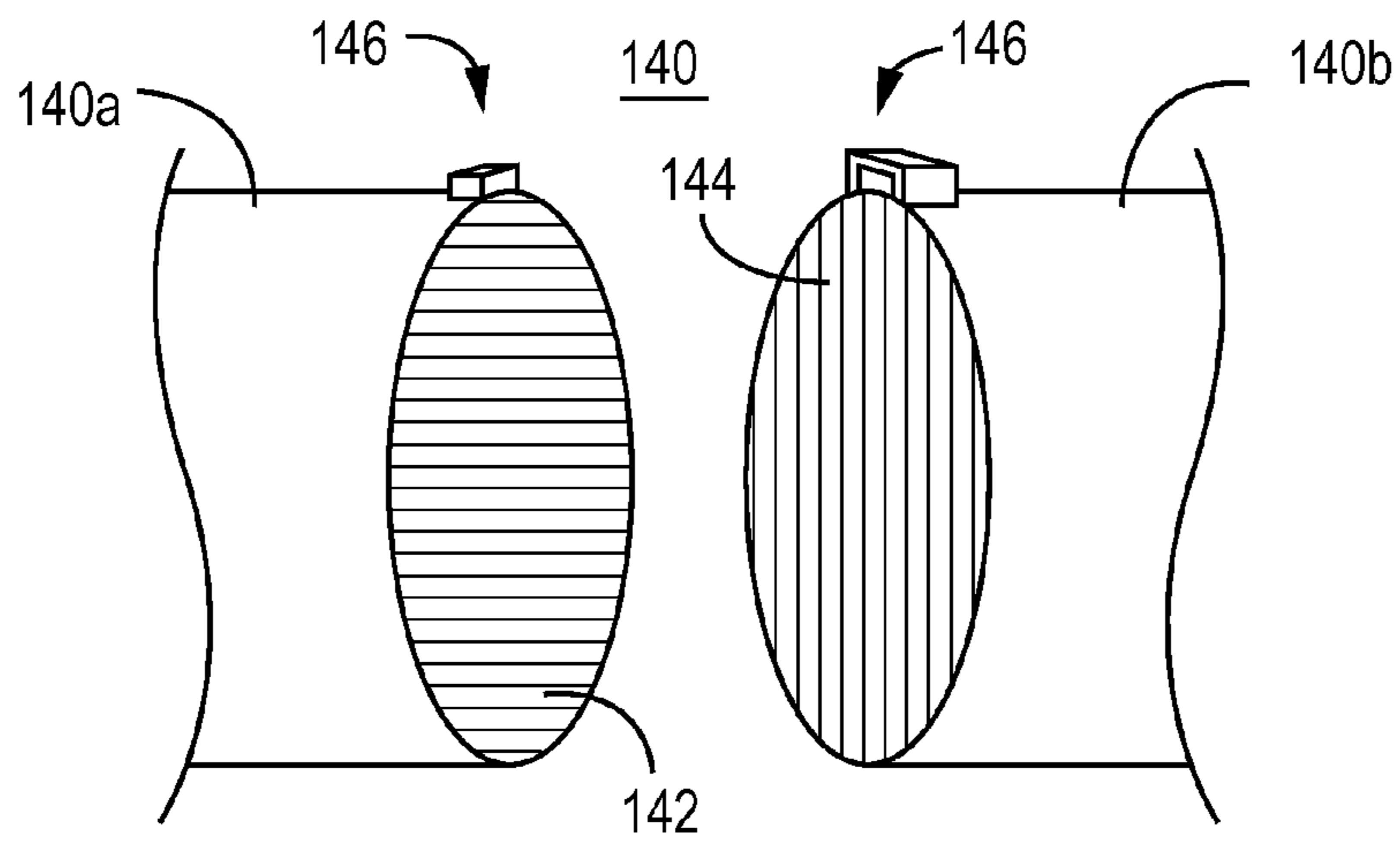

FIG. 6A

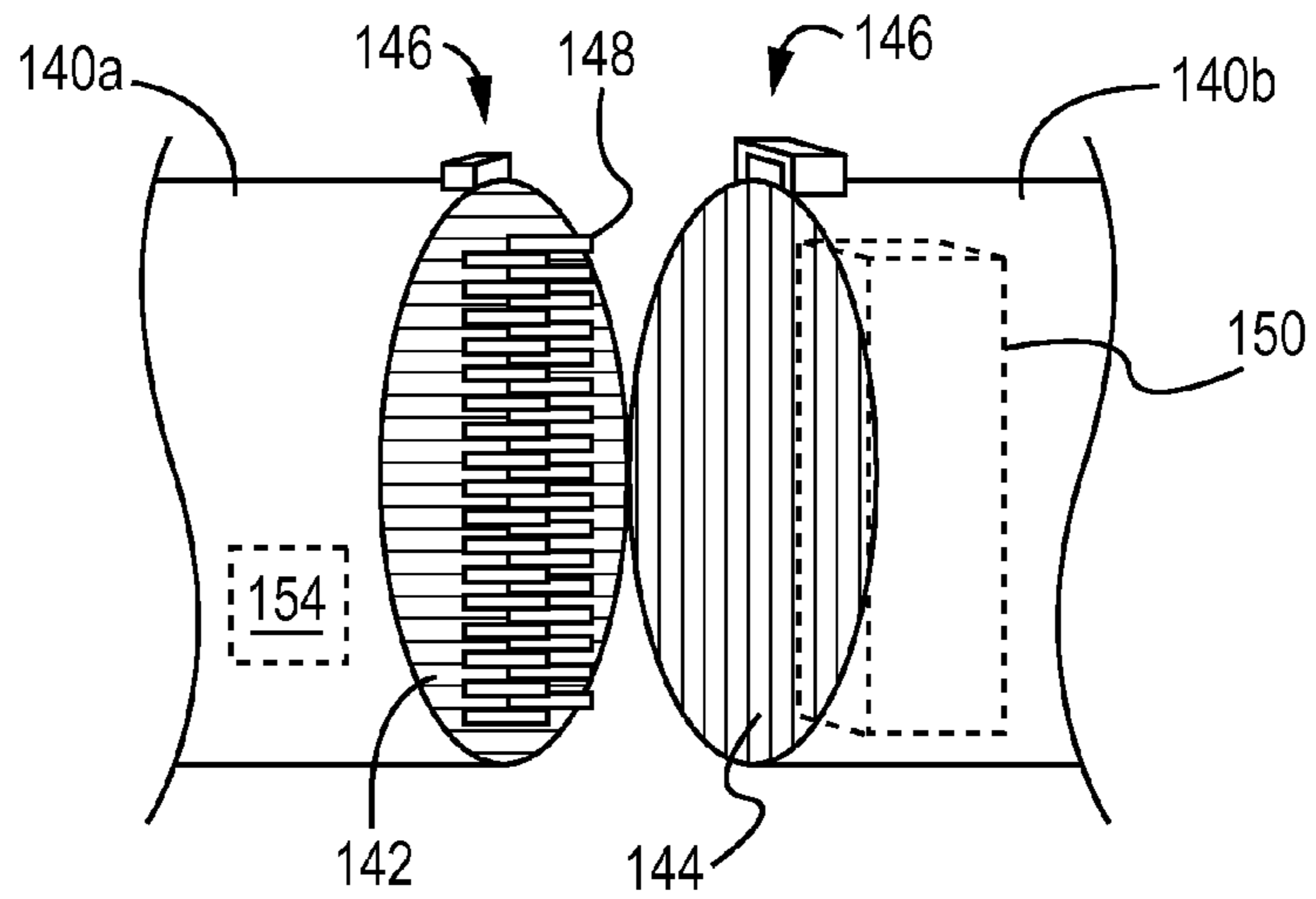

FIG. 6B

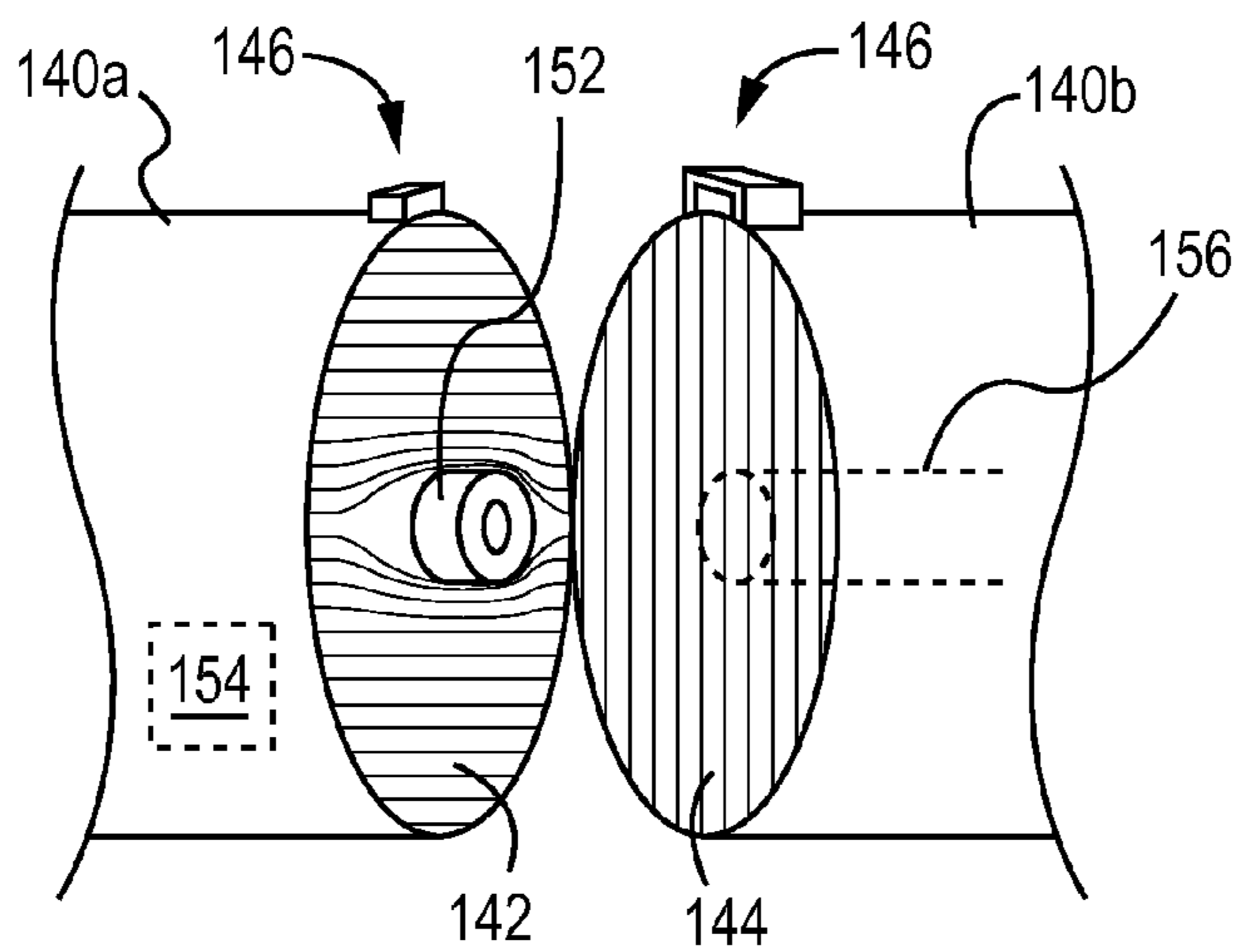

FIG. 6C

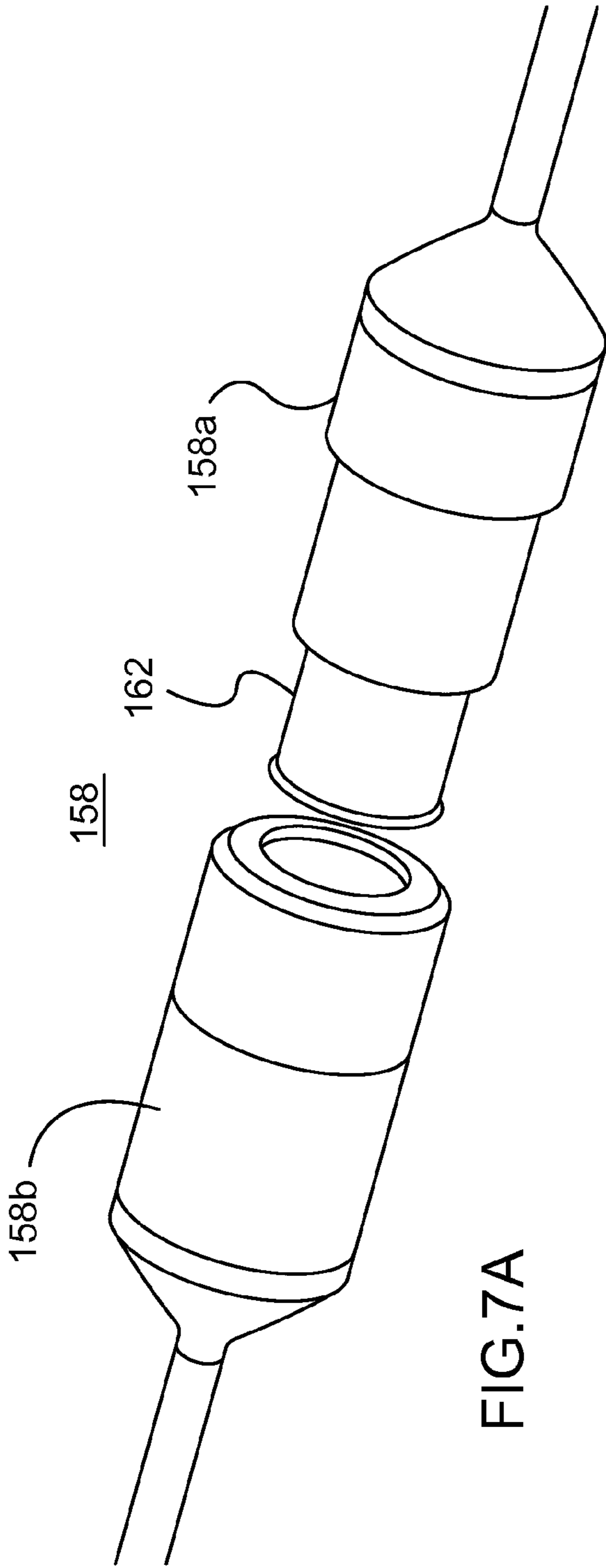

FIG. 7A

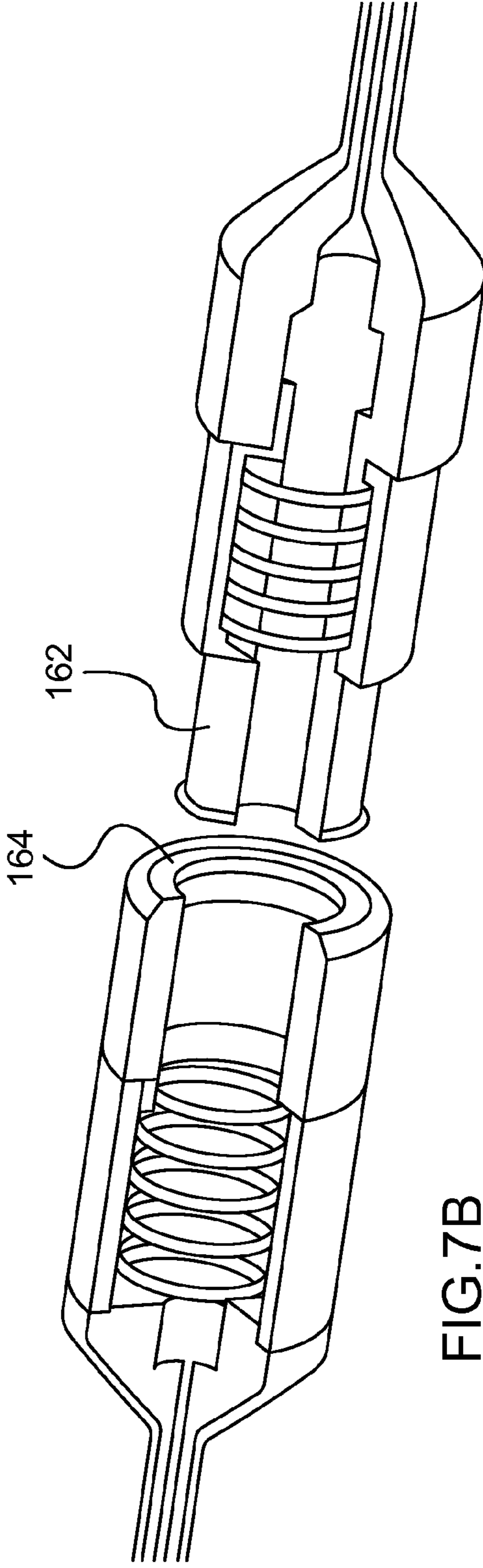
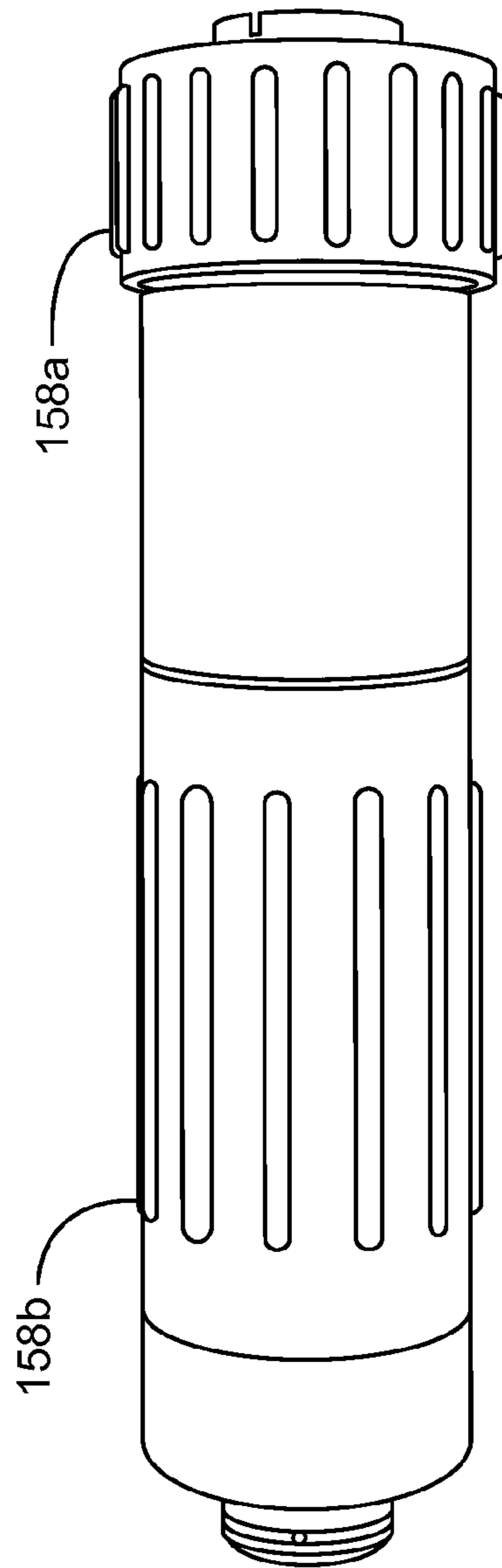
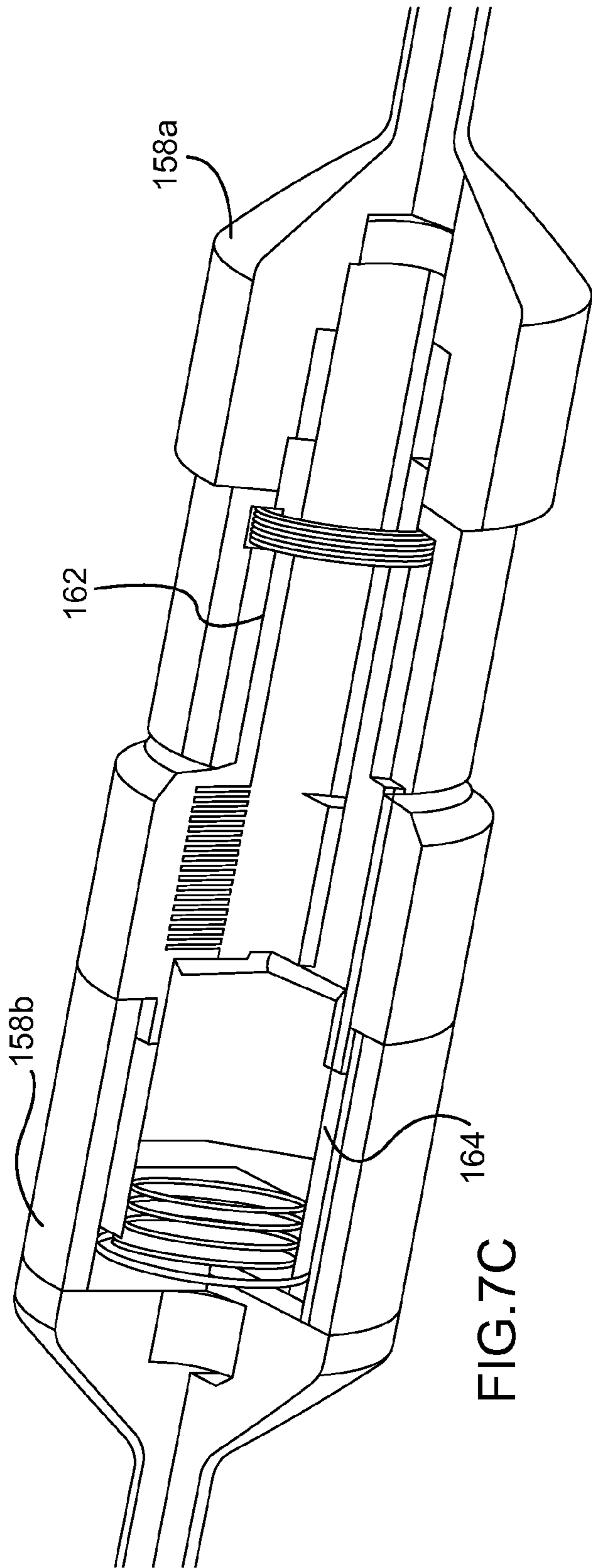

FIG. 7B



158b

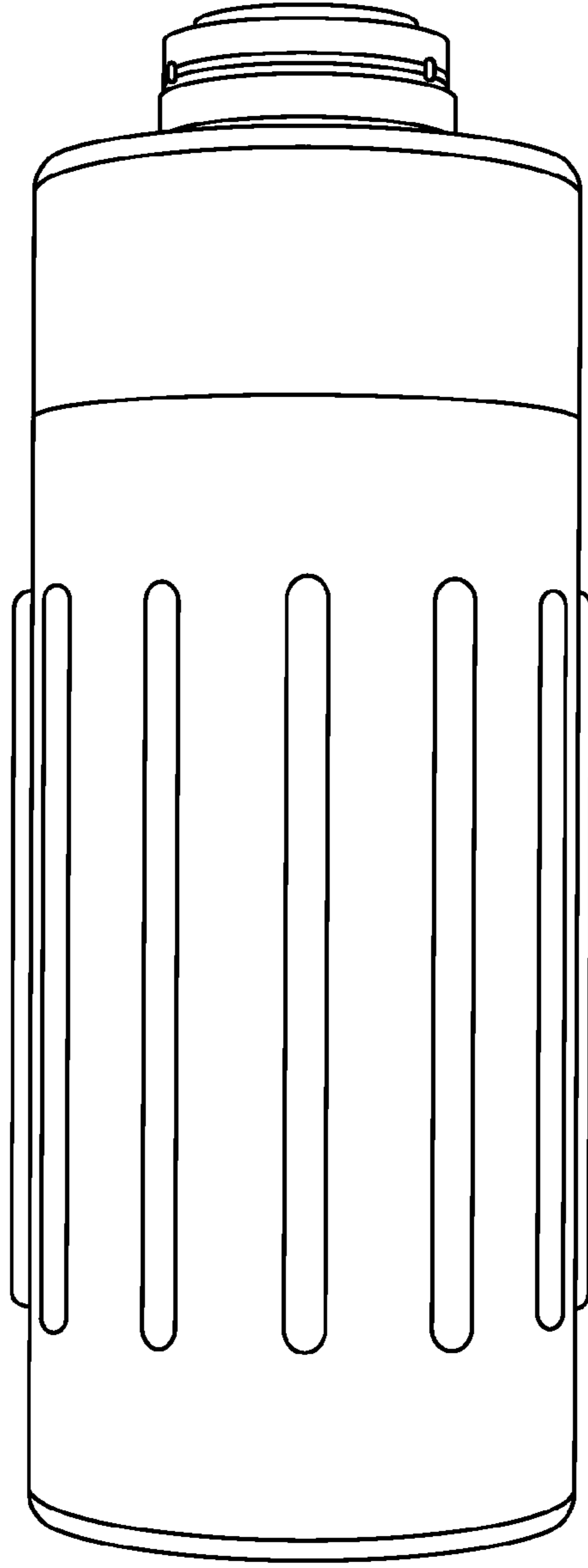
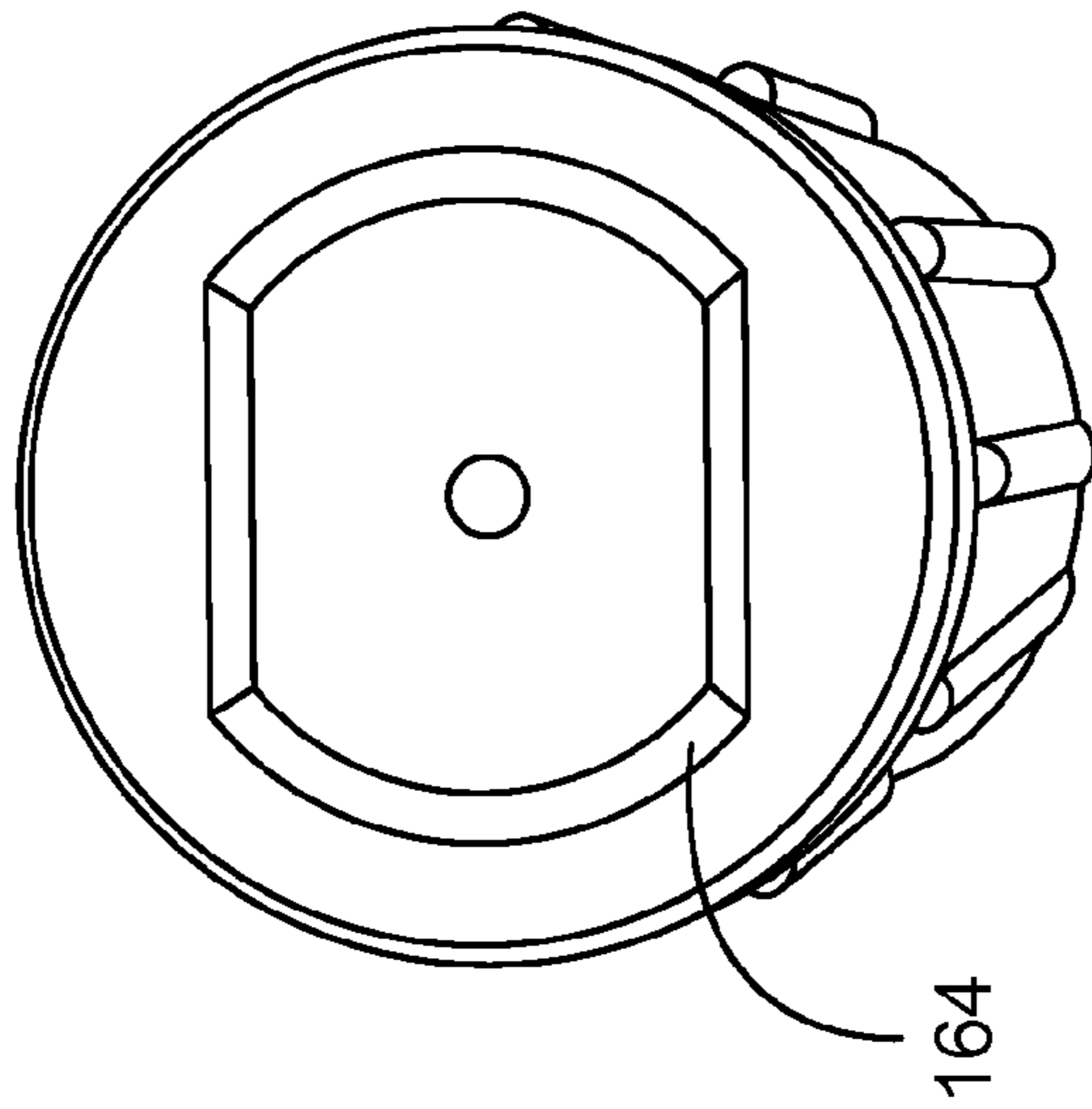

FIG. 7F

158b



164

FIG. 7E

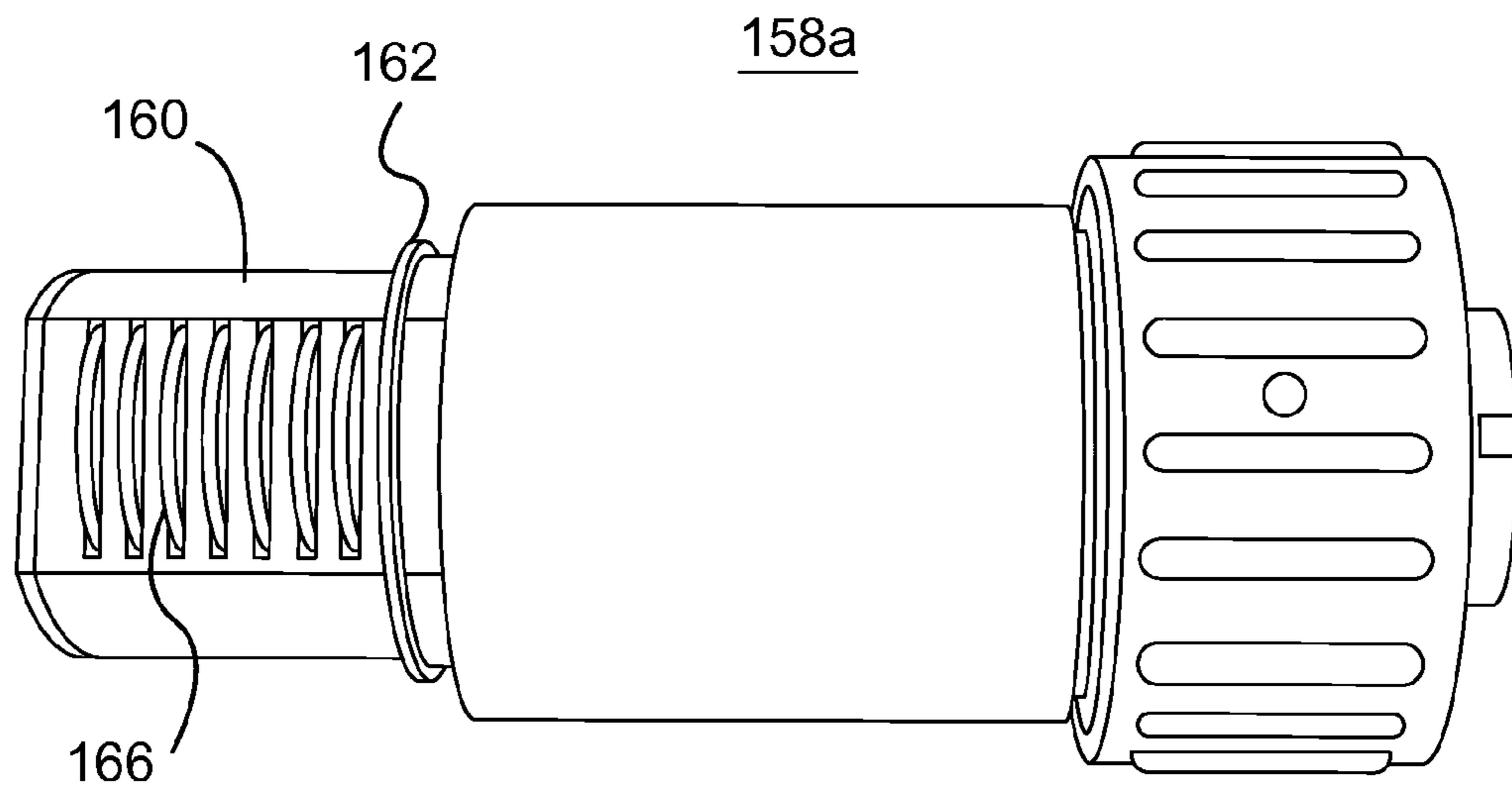

FIG.7G

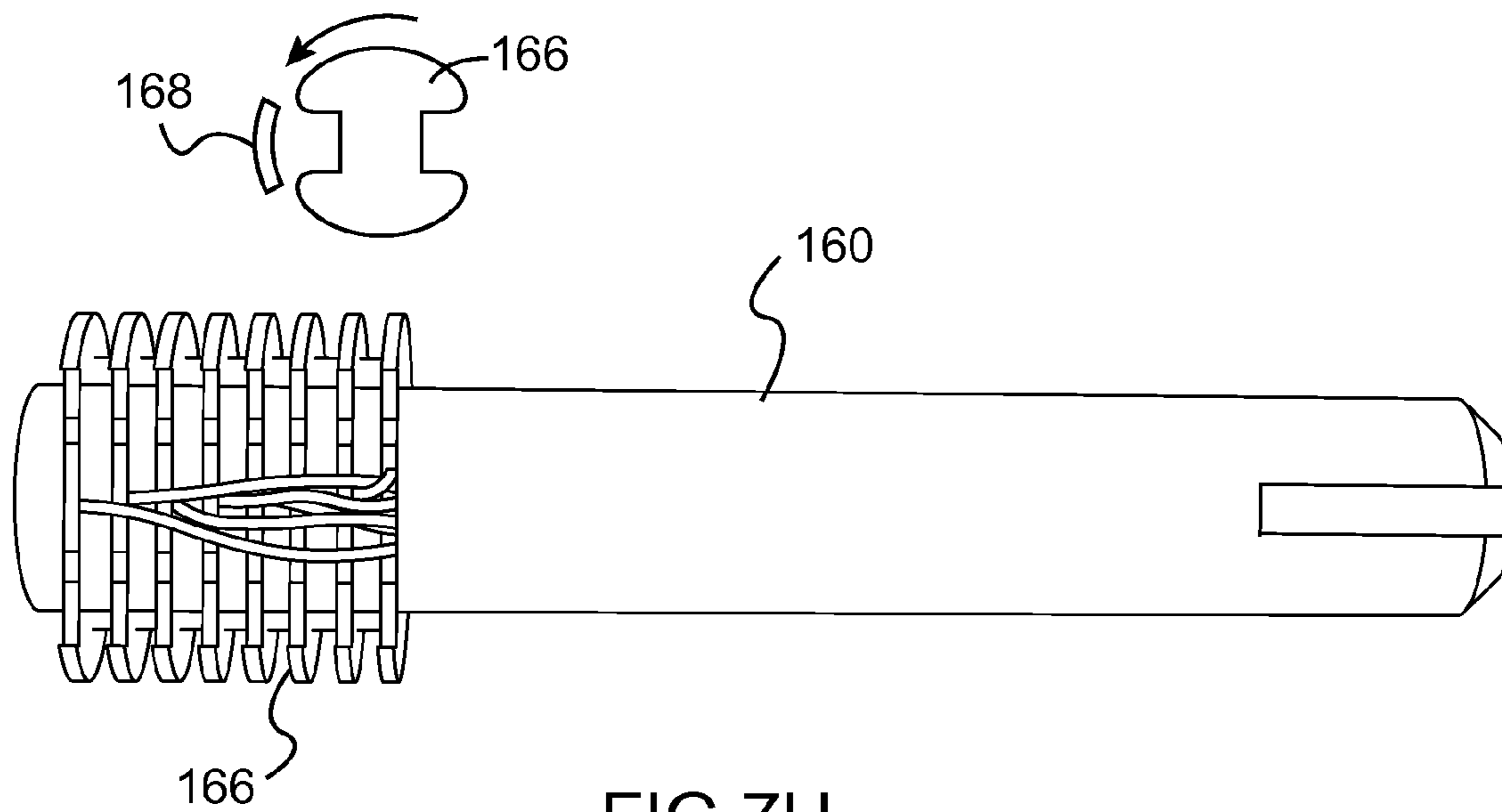

FIG.7H

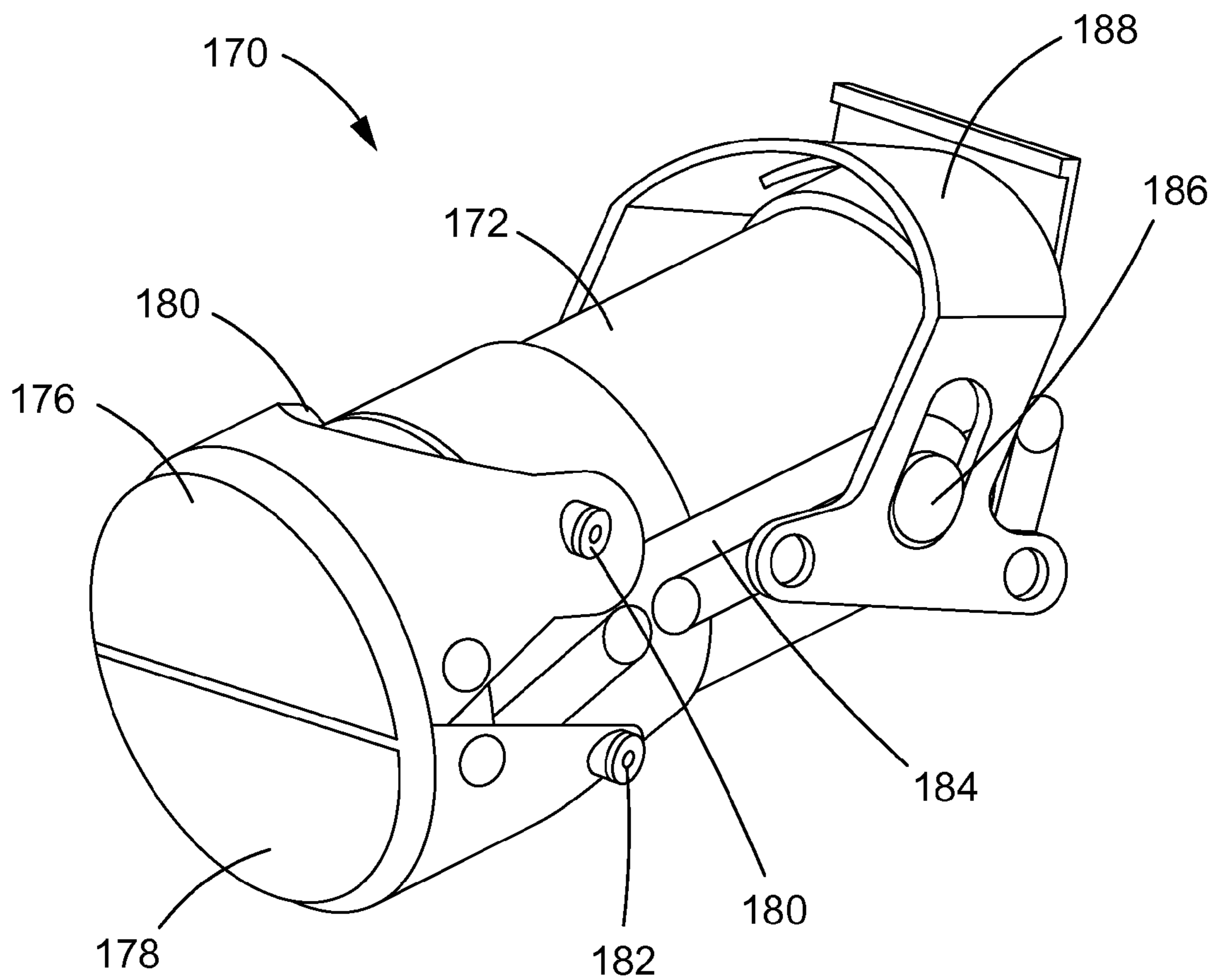

FIG. 8A



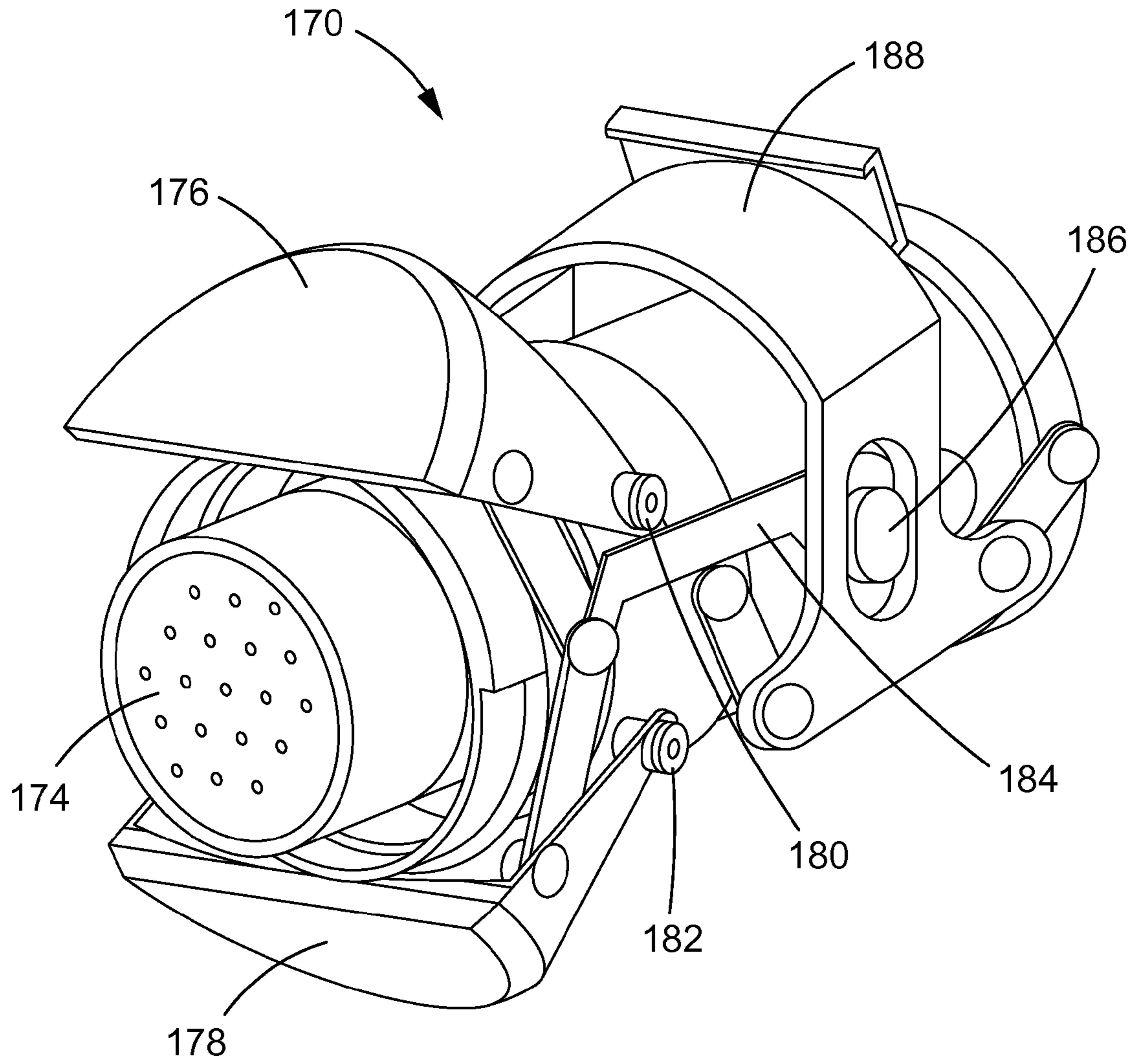

FIG.8B

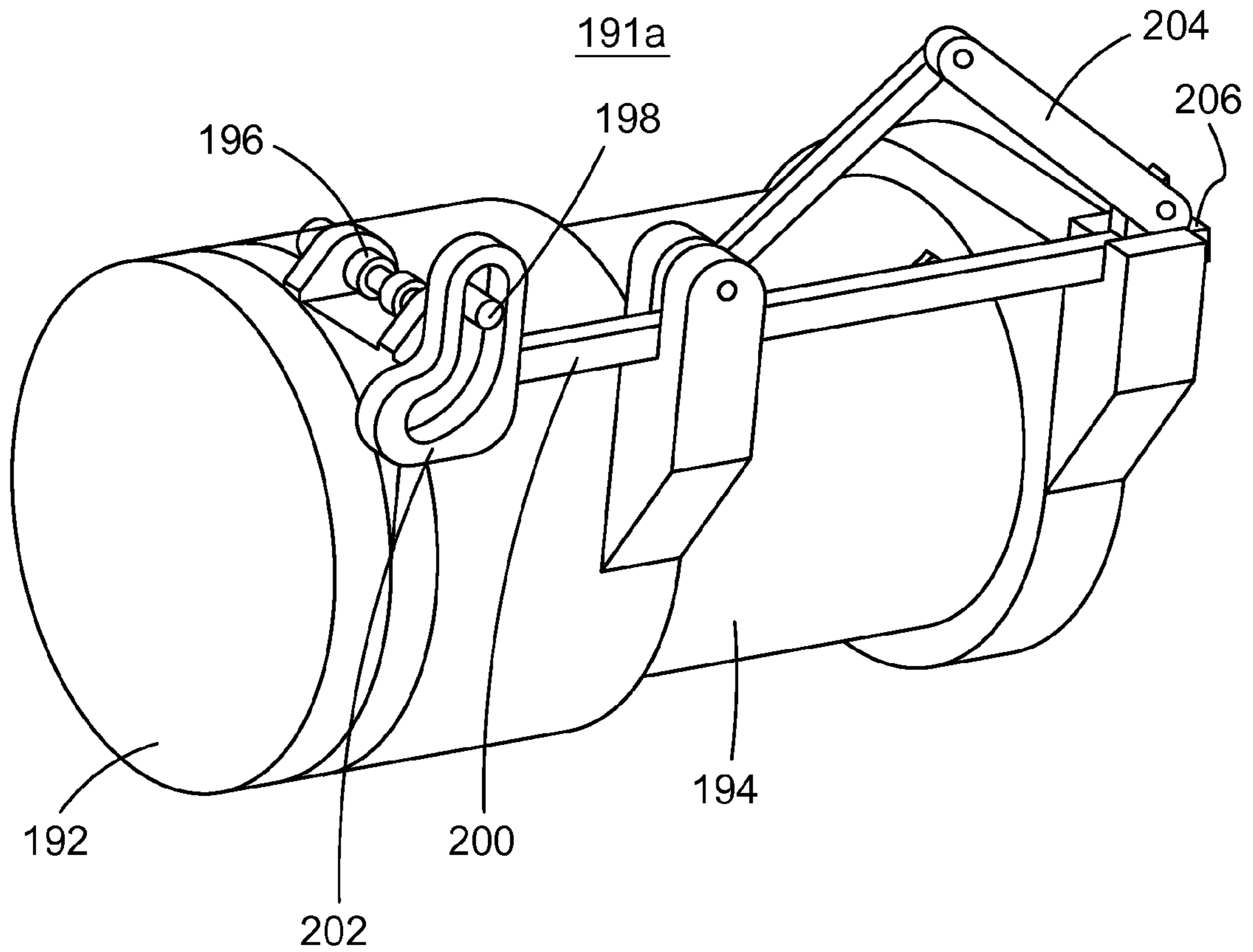

FIG.9A

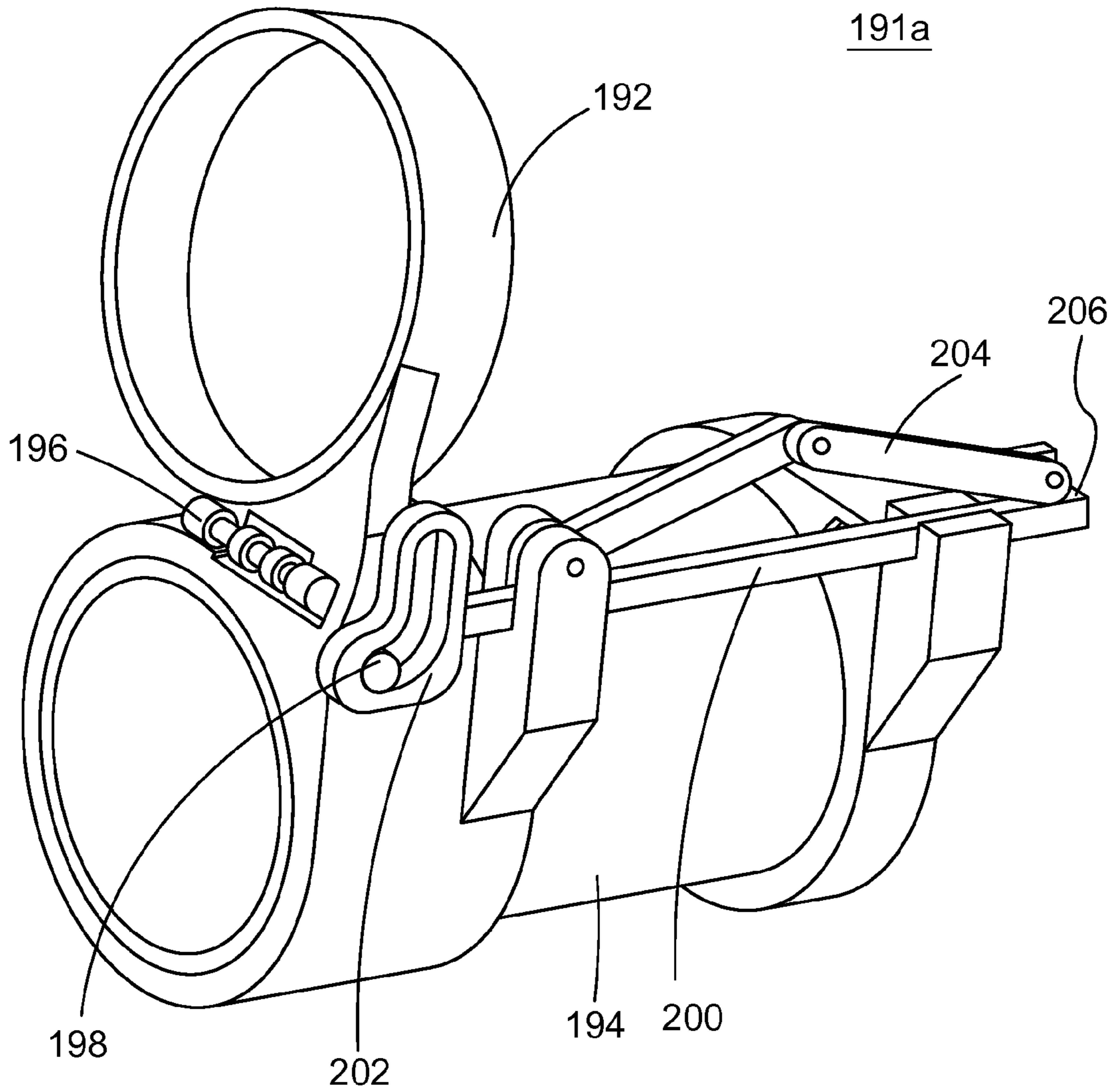
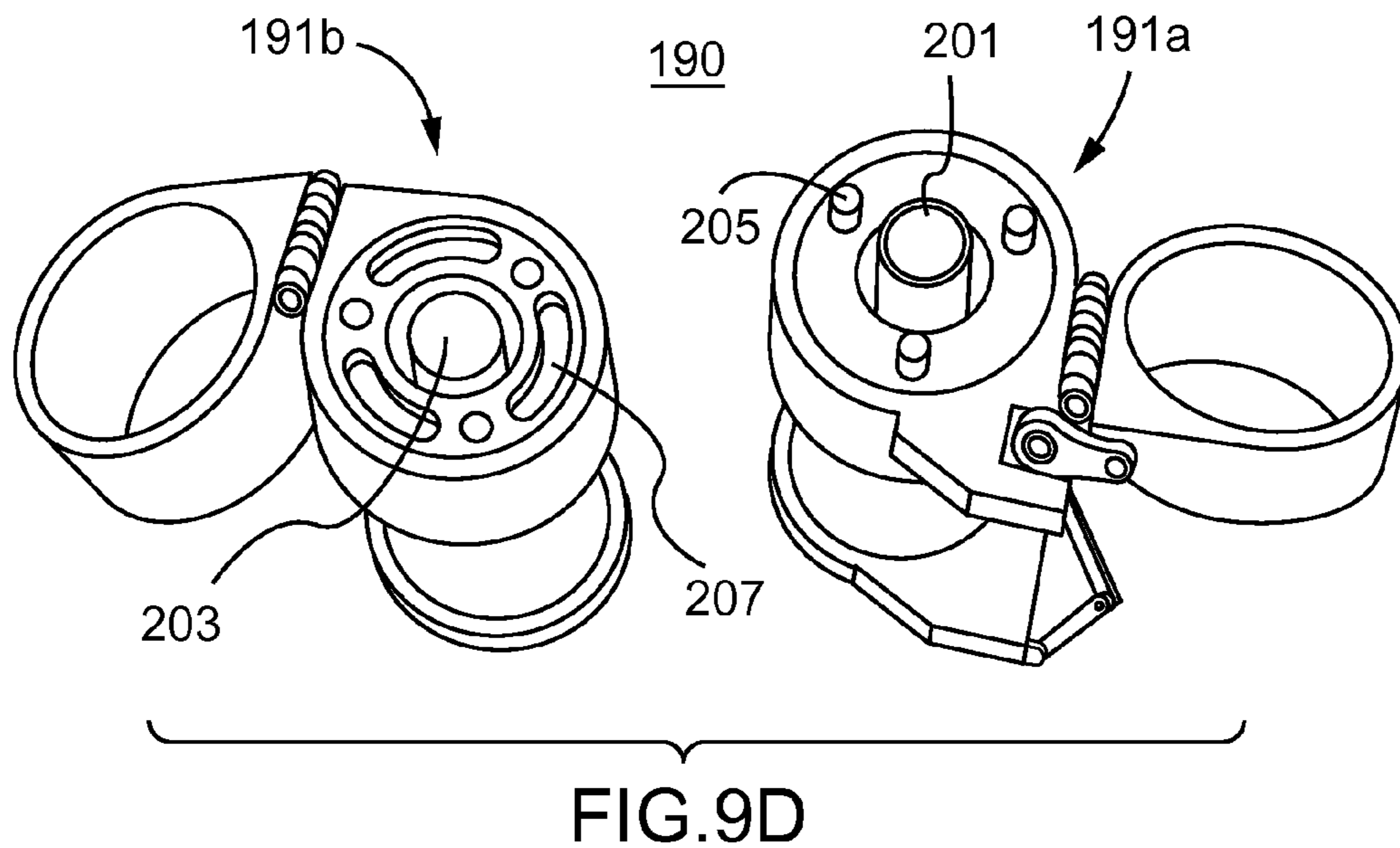
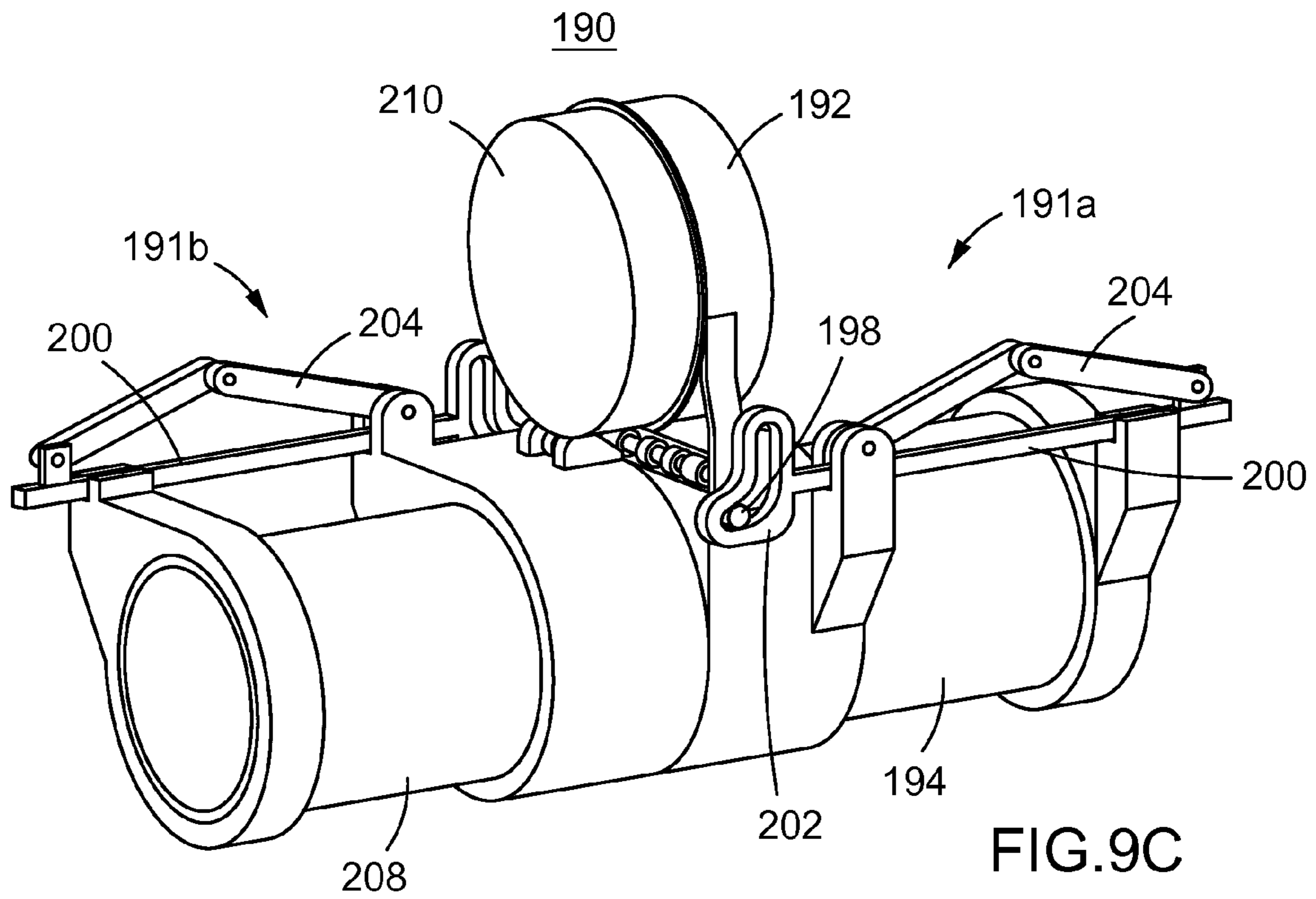

FIG.9B



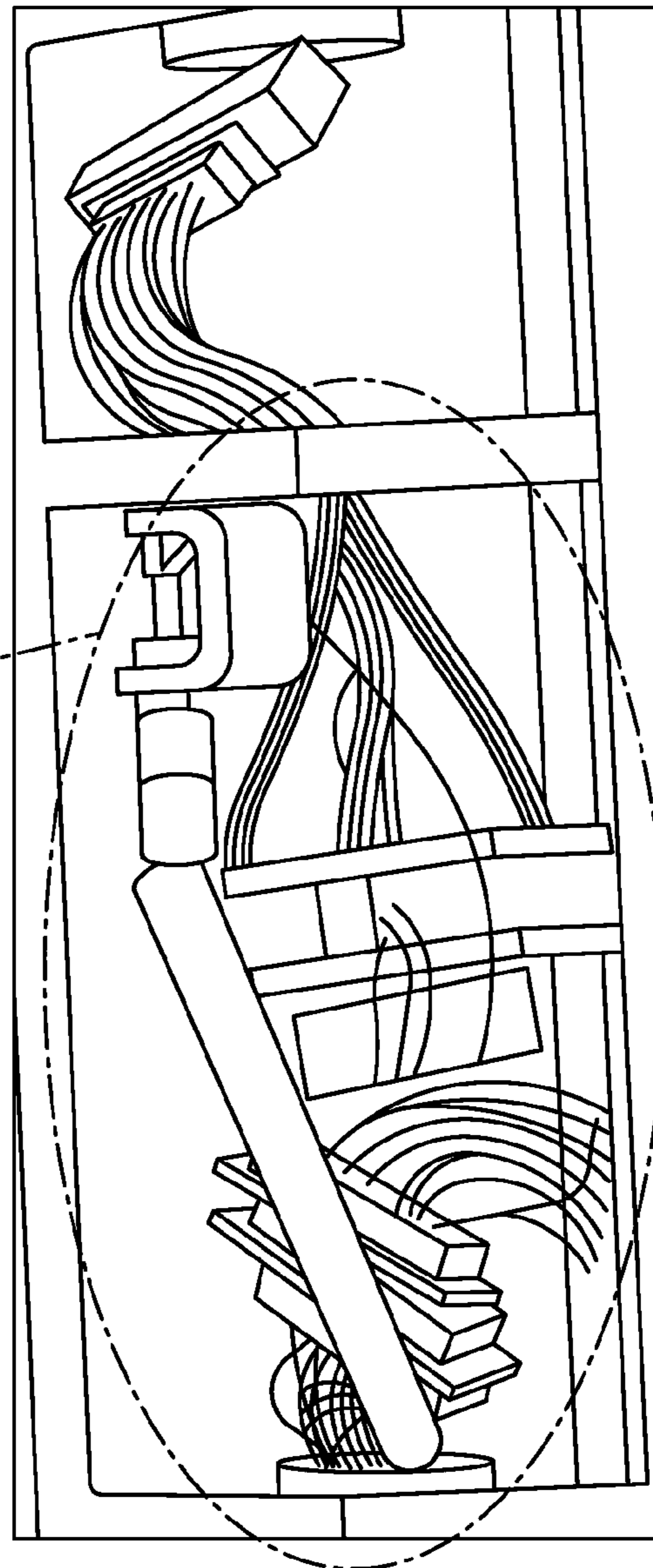
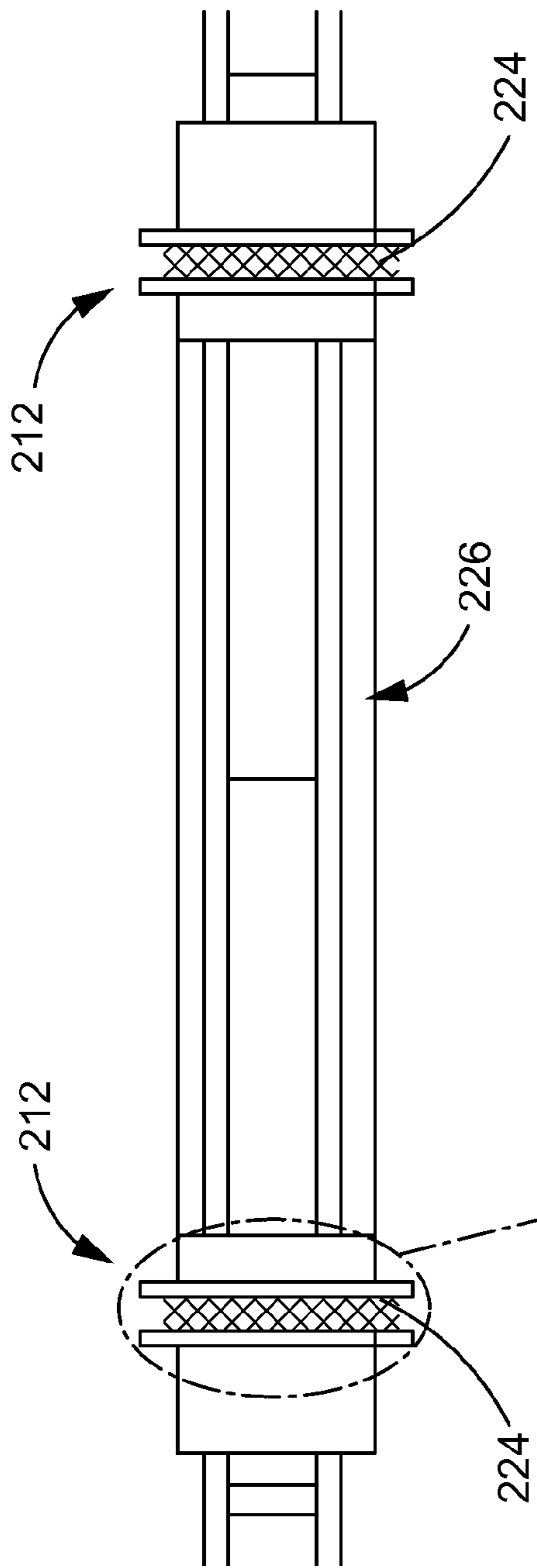

FIG. 10A

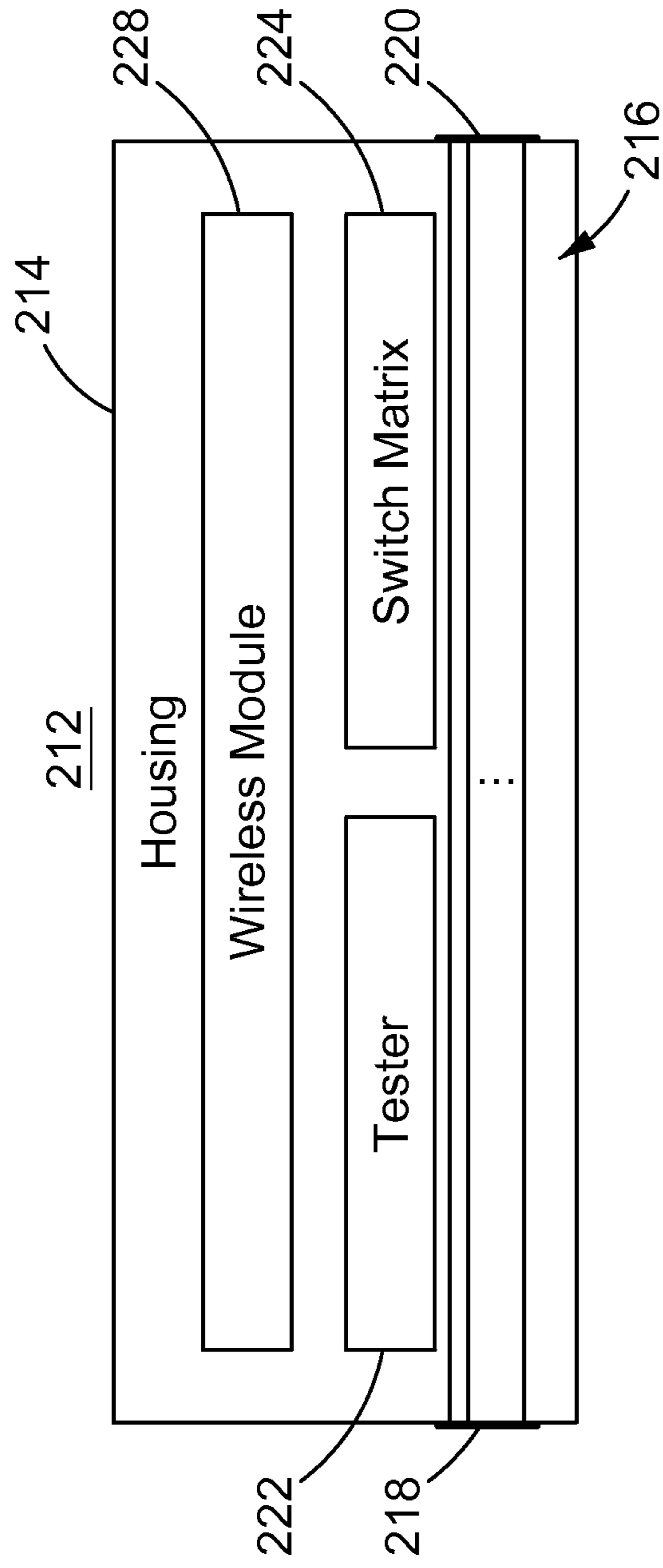
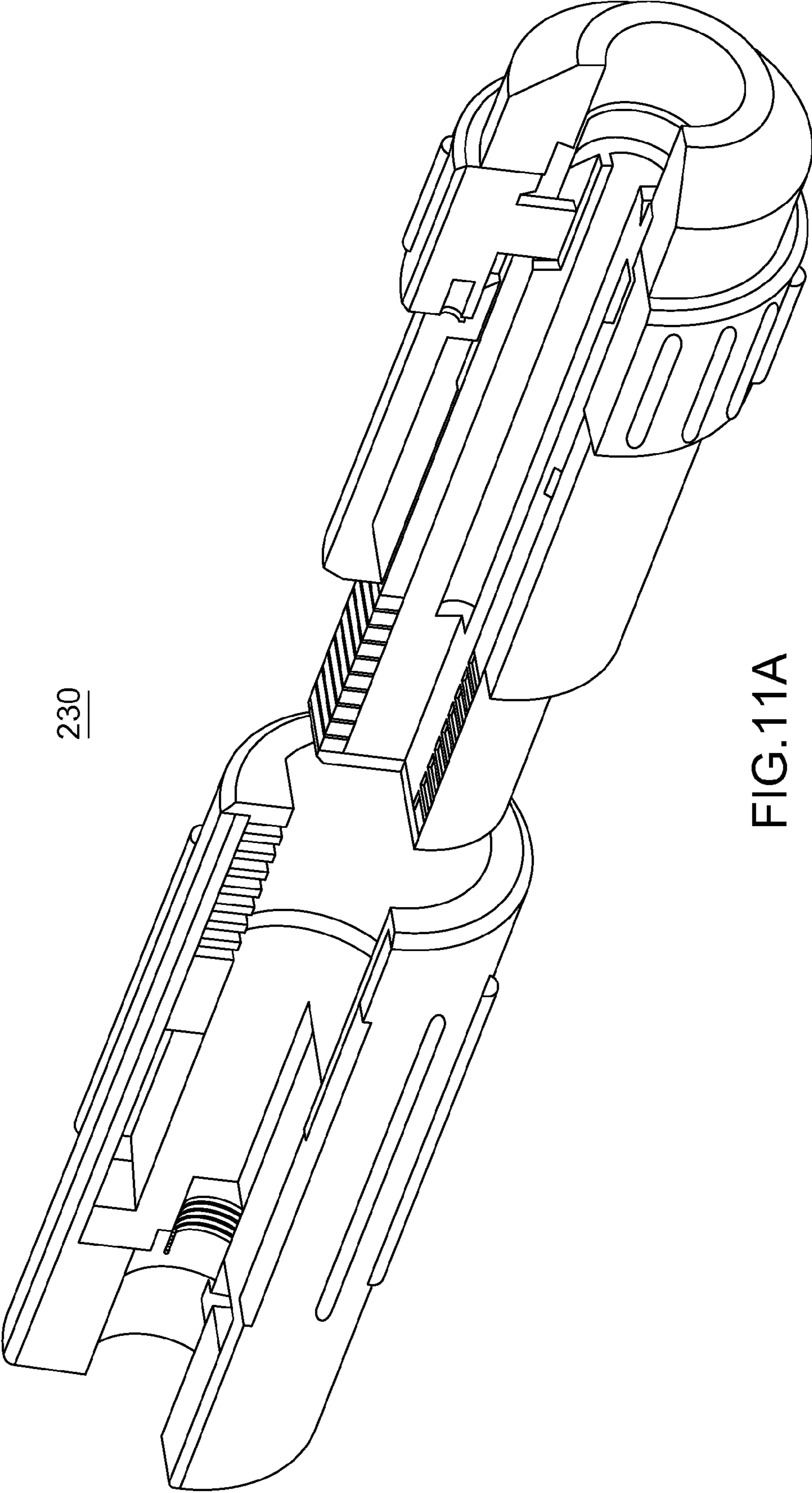
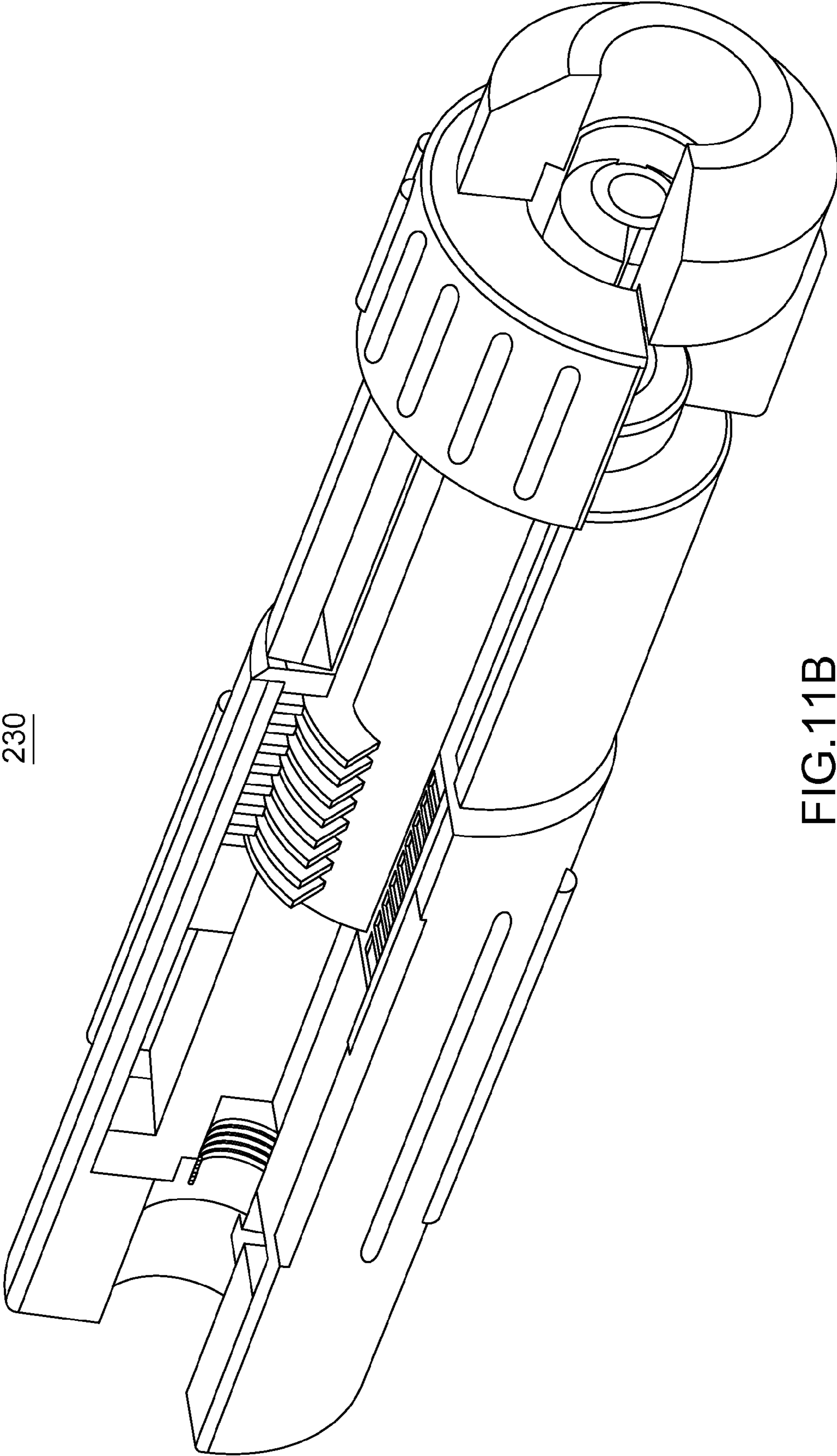

FIG.10B



230

FIG.11A



230

FIG.11B



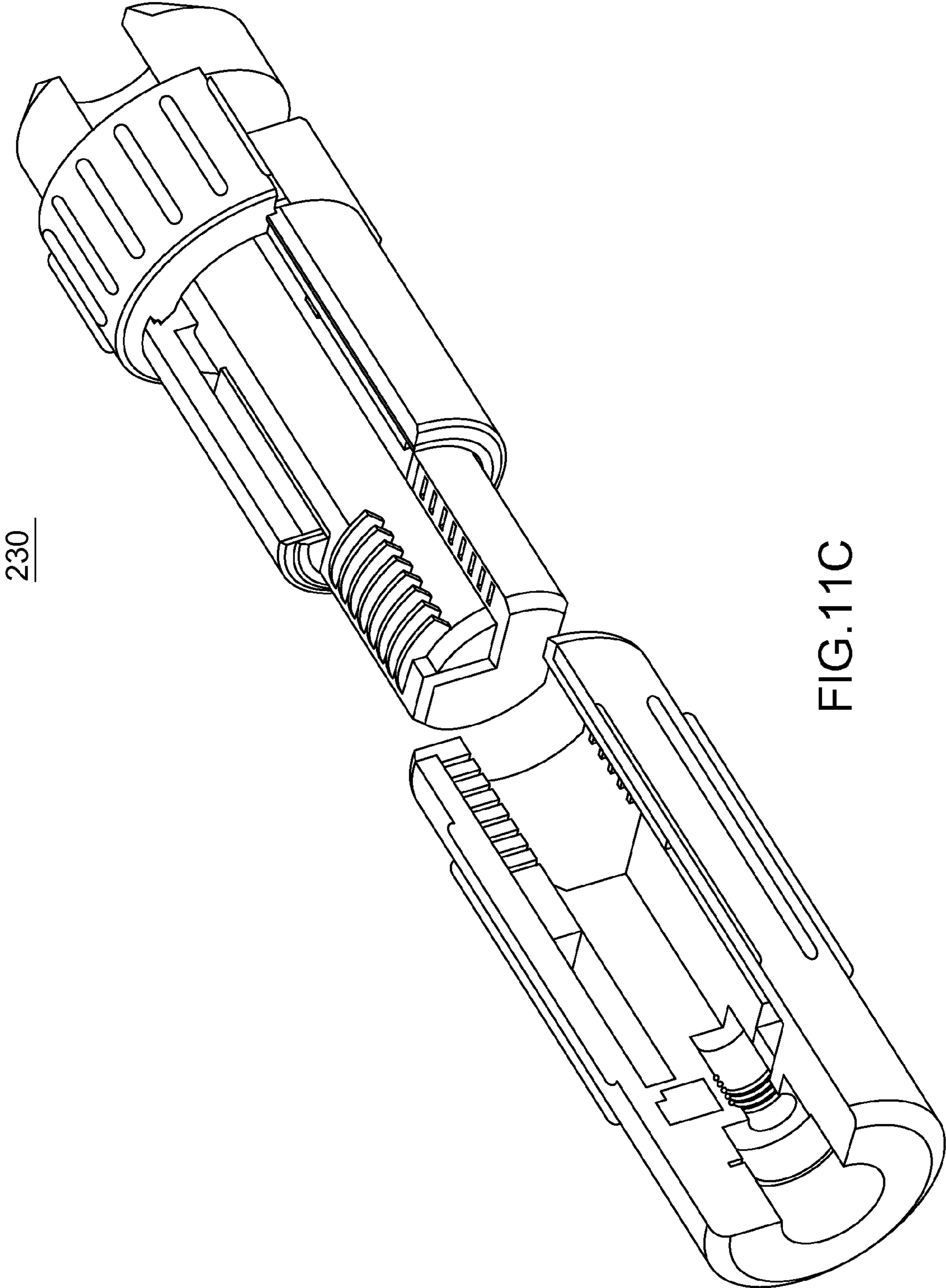

230

FIG.11C

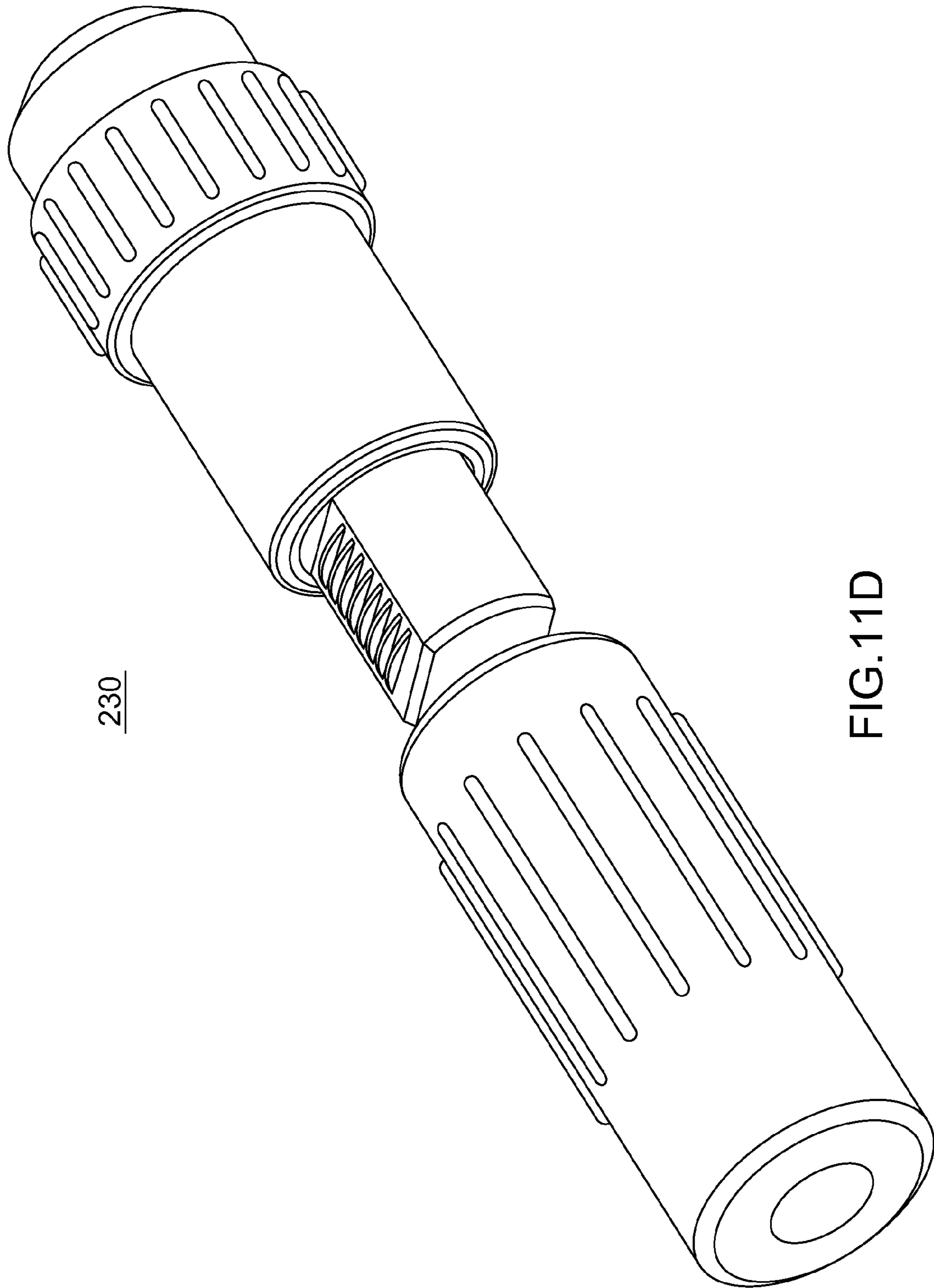

230

FIG.11D

**DUST TOLERANT CONNECTORS****CROSS-REFERENCE TO RELATED APPLICATIONS**

This application claims the benefit of priority under 35 U.S.C. §119(e) to U.S. Provisional Application Ser. No. 61/778,387, filed Mar. 12, 2013; Provisional Application Ser. No. 61/779,045, filed on Mar. 13, 2013; Provisional Application Ser. No. 61/779,200, filed on Mar. 13, 2013; Provisional Application Ser. No. 61/779,292, filed on Mar. 13, 2013; and Provisional Application Ser. No. 61/779,367, filed on Mar. 13, 2013, the contents of which are incorporated herein by reference in their entirety.

**ORIGIN OF THE INVENTION**

The invention described herein was made in the performance of work under a NASA contract and by employees of the United States Government and may be manufactured and used by or for the Government for governmental purposes without the payment of any royalties thereon or therefore.

**BACKGROUND OF THE INVENTION****1. Technical Field**

Embodiments of the invention generally relate to connectors. More particularly, embodiments relate to dust tolerant connectors. Some embodiments also relate to an intelligent connector system capable of detecting damage to or faults within a conductor and then rerouting the energy to a non-damaged spare conductor.

**2. Discussion**

Connectors of the present invention may be used to transfer electrical current, fluid, and gas in a wide variety of environments containing dust and other debris, wherein that debris may present substantial challenges. For example, lunar/Martian dust intrusion and/or accumulation in connectors used to transfer oxygen, hydrogen, nitrogen, etc., may lead to larger system failures as well as loss of life in extraterrestrial human exploration endeavors. Additionally, embodiments of the present invention may also be suitable for use where connectors must resist water intrusion, such as terrestrial deep water operations.

**BRIEF DESCRIPTION OF THE DRAWINGS**

The various advantages of the embodiments of the present invention will become apparent to one skilled in the art by reading the following specification and appended claims, and by referencing the following drawings, in which:

FIGS. 1A-1H show isometric and side views of examples of apparatuses having inverting end caps with a multi-axis lever configuration according to embodiments;

FIGS. 2A-2J show isometric and side views of examples of apparatuses having inverting end caps with enlarged handle and/or side rail configurations according to embodiments;

FIGS. 3A-3G show isometric and side views of an example of an apparatus having a rotating end cap configuration according to an embodiment;

FIGS. 4A-4E show sectional views of an example of an apparatus having a poppet valve configuration according to an embodiment;

FIGS. 5A and 5B show side views of an example of an apparatus having an O-ring configuration according to an embodiment;

FIGS. 6A-6C show side views of examples of apparatuses having a filament barrier configuration according to embodiments;

FIGS. 7A-7H show isometric, cut-away, side and end views of an example of a retractable cover configuration according to embodiments;

FIGS. 8A and 8B show isometric views of an example of a clamshell configuration according to an embodiment;

FIGS. 9A-9D show isometric views of an example of a flip cap configuration according to an embodiment;

FIGS. 10A and 10B show block diagrams of examples of an intelligent electrical connector according to an embodiment; and

FIGS. 11A-11D show isometric and cut-away views of an example of a retractable cover configuration according to additional embodiments.

**DETAILED DESCRIPTION OF THE INVENTION**

The intrusion and/or accumulation of dust and other debris or contaminants within electrical, fluid, and/or gas connectors may be prevented via a number of techniques described herein. The techniques may provide for rapid, clean connections, as well as quick disconnect (QD) operability by individuals wearing thick gloves (e.g., astronauts, drilling personnel, manufacturing personnel, deep-sea divers, etc.) without compromising the internal or external mating surfaces. For example, debris exclusion and removal apparatuses having 1) inverting end caps with a multi-axis lever configuration, 2) inverting end caps with enlarged handle and/or side rail configurations, 3) rotating end cap configurations, 4) poppet valve configurations, 5) O-ring configurations, 6) filament barrier configurations, 7) retractable cover configurations, 8) clamshell end cap configurations, etc., or any combination thereof, may be used to improve both the operability and the safety of connections in a wide variety of harsh environments.

**Inverting End Caps—Multi-Axis Lever**

FIGS. 1A-1H show a set of housings **20** (**20a**, **20b**) that may be used to couple a corresponding pair of connectors (not shown) to one another in an environment containing dust, debris, and/or other contaminants. As best shown in FIGS. 1B and 1H, a first housing **20a** may include an open end **22** and one or more surfaces defining a first cavity to receive/contain a first connector such as, for example, an electrical connector, a fluid connector, a gas connector, etc., or any combination thereof. The illustrated first housing **20a** also has a first cap **24** (e.g., an “end cap”) that is movable between a closed position (e.g., as shown in FIG. 1A) in which the open end **22** of the first housing **20a** is covered by the first cap **24** and an open position (e.g., as shown in FIGS. 1B-1H) in which the open end **22** of the first housing **20a** is not covered by the first cap **24**.

In addition, a first hinge **26** may be coupled to the first housing **20a** and the first cap **24**, wherein the first hinge **26** inverts the first cap **24** between the closed position and the open position. As best shown in FIG. 1H, the first hinge **26** may include a bending tension spring **28** having a shape memory alloy that biases the first cap **24** toward the closed position. Such a biasing operability may ensure that the first housing **20a** automatically closes before touching the ground if dropped by an individual handling the first housing **20a**. Indeed, the automatic closing of the first housing **20a** may be particularly advantageous if the ground and/or floor of the environment contains a relatively large amount of debris or other contaminants.

The illustrated first housing **20a** also includes a first multi-axis lever **30** (e.g., a “lazy tong”) coupled to the external surface of the first housing **20a** and the first hinge **26**. The first multi-axis lever **30** (**30a**, **30b**) may generally invert the first cap **24** to the open position (e.g., actuate) when the first multi-axis lever **30** is squeezed toward the external surface of the first housing **20a**. In the illustrated example, the first multi-axis lever **30** includes a first member **30a** having a fixed end coupled to the first housing **20a** via a pin that provides an axis of rotation, and a second member **30b** having a first free end coupled to a free end of the first member **30a** via another pin that provides another axis of rotation. The second member **30b** may also have an intermediate point coupled to the first housing **20a** via a pin that provides yet another axis of rotation so that squeezing the first member **30a** toward the external surface of the first housing **20a** causes a second free end of the second member **30b** to rotate away from external surface of the first housing **20a**.

As best seen in FIGS. 1B and 1H, the second free end of the second member **30b** may include a hook **32** and the first cap **24** may include a protrusion **34** at a periphery of the first cap **24**, wherein the hook **32** engages with the protrusion **34** when the first cap **24** is in the closed position. Moreover, the second free end of the second member **30b** may be coupled to the first cap **24** via a cable **36** that enters the first housing **20a** on one side wraps around an interior region of the first housing **20a**, exits the first housing **20a** on the other side, loops over the pin of the first hinge **26** (as best shown in FIG. 1A) and attaches to the first cap **24**. Accordingly, when the second free end of the second member **30b** moves away from the first housing **20a**, the cable **36** pulls the first cap **24** to the open position, in the illustrated example. Of particular note is that the illustrated approach provides a relatively high amount of rotational movement on the part of the first cap **24** (e.g., 180°+), by virtue of a relatively small amount of linear movement of the free end of the first member **30a** (e.g., on the order of centimeters). As a result, the illustrated first housing **20a** can be actuated with very little effort by individuals wearing thick gloves (e.g., having limited manual dexterity).

In addition, a second housing **20b** may include an open end **38** and one or more surfaces defining a second cavity to receive/contain a second connector such as, for example, an electrical connector, a fluid connector, a gas connector, etc., or any combination therefore, that mates with the first connector of the first housing **20a**. The illustrated second housing **20b** has a second cap **40** (e.g., end cap) coupled to the second housing **20b**, and a second hinge **42** coupled to the second housing **20b** and the second cap **40**, wherein the second hinge **42** inverts the second cap **40** between the closed position and the open position. As best shown in FIGS. 1F and 1G, when the open end of the first housing **20a** and the open end of the second housing **20b** are coupled to one another, the first cap **24** and the second cap **40** seal one another.

In this regard, the first cap **24** may also include a gasket **44** to effectuate the seal between the first cap **24** and the second cap **40**. Moreover, the gasket **44** may be used to improve the seal between the first cap **24** and a corresponding surface **46** (e.g., best shown in FIG. 1H) of the first housing **20a** when the first cap **24** is in the closed position. A similar gasket (not shown) may be provided on a surface **48** (e.g., best shown in FIG. 1H) of the second housing **20b** that interfaces with the second cap **40** when the second cap **40** is in the closed position. Additionally, the open end **22** of the first housing **20a** may include a set of laterally extending

protrusions **50** that correspond to a set of apertures **52** in the open end **38** of the second housing **20b**, wherein the protrusions **50** and apertures **52** operate as a cam and groove coupling that locks the first and second housings **20** to one another via rotation. The rotation may in fact cause a friction based removal of contaminants from surfaces such as, for example, the surface **46** and/or the surface **48**. The second housing **20b** may have a multi-axis lever similar to that of the first housing **20a**.

Inverting End Caps—Enlarged Handle and/or Side Rail  
 FIGS. 2A-2E show another example of a set of housings **54** (**54a**, **54b**) that may be used to couple a corresponding pair of connectors to one another in an environment containing dust and/or other debris. A first housing **54a** may have an open end and one or more surfaces defining a first cavity to receive/contain a first connector (e.g., including a set of pins, as best shown in FIG. 2B). The first housing **54a** may also include a first cap **56** coupled to the first housing **54a**, wherein the first cap **56** is movable between a closed position (e.g., as shown in FIG. 2A) in which the open end of the first housing **54a** is covered by the first cap **56** and an open position (e.g., as shown in FIGS. 2B-2E) in which the open end of the first housing **54a** is not covered by the first cap **56**. In addition, a first hinge may be coupled to the first housing **54a** and the first cap **56**, wherein the first hinge inverts the first cap **56** between the closed position and the open position.

Similarly, a second housing **54b** may include an open end (e.g., as best shown in FIG. 2C) and one or more surfaces defining a second cavity to receive/contain a second connector (e.g., including a socket, as best shown in FIG. 2C). The illustrated second housing **54b** also includes a second cap **58** coupled to the second housing **54b** and a second hinge coupled to the second housing **54b** and the second cap **58**, wherein the second hinge inverts the second cap **58** between the closed position and the open position. As best shown in FIGS. 2D and 2E, when the open end of the first housing **54a** and the open end of the second housing **54b** are coupled to one another, the first cap **56** and the second cap **58** may seal one another.

More particularly, a first handle is coupled to the first cap **56**, a second handle is coupled to the second cap **58**, and a locking system is used to effectuate the seal between the first cap **56** and the second cap **58**, in the illustrated example. The locking system may include an actuation rod extending laterally through a longitudinal slot of the second housing **54b** and a rotatable sleeve **60** external to the second housing **54b**. In one example, the actuation rod is coupled to the second connector and the rotatable sleeve **60** is coupled to the actuation rod so that rotating the sleeve **60** upward (e.g., counterclockwise in FIG. 2A) pushes the actuation rod forward in the longitudinal slot and in turn fully mates the two connectors with one another so that the caps **56**, **58** press against one another. Moreover, an additional component such as a torsional spring may be used at the hinged connection between the caps **56**, **58** and their respective housings in order to bias the caps **56**, **58** toward one another in the mated position. The enlarged handles and the locking mechanism may enable the housings **54** to be connected with very little effort by individuals wearing thick gloves.

FIGS. 2F-2J show yet another example of a set of housings **62** (**62a**, **62b**) that may be used to couple a corresponding pair of connectors to one another in an environment containing dust and/or other debris. A first housing **62a** may have an open end and one or more surfaces defining a first cavity to receive/contain a first connector. The first housing **62a** may also include a first cap **64** coupled

to the first housing **62a**, wherein the first cap **64** is movable between a closed position (e.g., as shown in FIGS. 2F and 2G) in which the open end of the first housing **62a** is covered by the first cap **64** and an open position (e.g., as shown in FIGS. 2H-2J) in which the open end of the first housing **62a** is not covered by the first cap **64**. In addition, a first hinge **66** may be coupled to the first housing **62a** and the first cap **64**, wherein the first hinge **66** inverts the first cap **64** between the closed position and the open position. In the illustrated example, the first hinge **66** includes a two-piece configuration in which each piece has an oblong slot that rides along a pin protruding from the side of the first housing **62a**.

Similarly, a second housing **62b** may include an open end and one or more surfaces defining a second cavity to receive/contain a second connector. The illustrated second housing **62b** also includes a second cap **68** coupled to the second housing **62b** and a second hinge **70** coupled to the second housing **62b** and the second cap **68**, wherein the second hinge **70** inverts the second cap **68** between the closed position and the open position. In the illustrated example, the second hinge **70** also includes a two-piece configuration in which each piece has one or more surfaces defining an oblong slot that rides along a pin protruding from the side of the second housing **62b**.

In one example, a plurality of side rails **72** are coupled to the exterior of the first housing **62a**, wherein each side rail **72** includes one or more surfaces defining a longitudinal slot. Additionally, the apparatus **62** may include a plurality of dual-member linkages **74**, wherein each dual-member linkage **74** rests in a longitudinal slot of a corresponding side rail **72** and forces the first and second caps **64**, **68** open when the second housing **62b** is mated with the plurality of side rails **72** (e.g., as best shown in FIGS. 2G and 2H). In this regard, the second housing **62b** may include a plurality of side channels **76** (e.g., as best shown in FIG. 2J) through which the side rails slide during mating and de-mating. The first housing **62a** may also include a frame **78** extending between the side rails **72** and around the first housing **62a** to provide structural support to the side rails **72** (e.g., particularly at their distal ends). As best shown in FIGS. 2I and 2J, when the open end of the first housing **62a** and the open end of the second housing **62b** are coupled to one another, the first cap **64** and the second cap **68** may seal one another.

#### Rotating End Caps

Turning now to FIGS. 3A-3G, a first housing **80** having an open end **84**, one or more surfaces defining a cavity to receive/contain a connector **86**, and a rotatable cap **82** is shown. More particularly, FIG. 3A demonstrates that the cap **82** covers the open end **84** of the first housing **80** in the closed position and FIG. 3B demonstrates that the cap **82** does not cover the open end **84** of the first housing **80** in the open position. Moreover, a side piece **88** may be coupled to the external surface of the first housing **80**, wherein the cap **82** includes a wiper **90** (e.g., sealing and/or doctoring blade, as best shown in FIG. 3C) positioned on the underside of the cap **82**. The wiper **90** may brush against the external surface of the side piece **88** as the cap **82** rotates to the open position. The illustrated wiper **90** also seals the open end **84** of the first housing **80** when the cap **82** is in the closed position. As best shown in FIGS. 3D-3G, a set of pins **92** may extend from opposing sides of the first housing **80** and define an axis, wherein the cap **82** is coupled to the first housing **80** via the set of pins **92**, and wherein the cap **82** is rotatable about the axis defined by the set of pins **92**.

Additionally, a pair of housings **80**, **81** may be used, wherein the open ends **84** of the housings **80**, **81** mate with one another to form an electrical, fluid and/or gas connec-

tion. Thus, a second housing **81** may also have surfaces defining a cavity to receive/contain a connector and a cap **82** coupled to the second housing **81**, wherein the cap **82** is rotatable between the closed position and the open position. In the illustrated example, an actuator assembly is used to form the connection between the housings **80**, **81** and their respective connectors. More particularly, the actuator assembly may include an actuator arm **94** and one or more surfaces that define a cavity to receive/contain the first and second housings **80**, **81**. Moreover, the actuator arm **94** may be coupled to the first housing **80** and move the first housing **80** longitudinally within the cavity of the actuator assembly during transitions of the caps **82** between the closed position and the open position.

In one example, a first set of pins **96** extend from opposing sides of the first housing **80**, wherein the actuator assembly further includes one or more surfaces defining a plurality of longitudinal slots **98** to receive the first set of pins **96** and guide the first housing **80** longitudinally within the third cavity during transitions of the caps **82** between the closed position and the open position. Additionally, a second set of pins **100** may extend from opposing sides of the second housing **81**, wherein the actuator assembly further includes one or more surfaces defining a plurality of stabilizing slots **102** (e.g., best shown in FIG. 3D) to receive the second set of pins **100**. The illustrated actuator assembly further includes a third set of pins **104** extending from opposing sides of the second housing **81**, wherein the plurality of longitudinal slots **98** receive the third set of pins **104** and guide the actuator arm **94** longitudinally during transitions of the caps **82** between the closed position and the open position.

#### Poppet Valves

FIGS. 4A-4E show a debris exclusion and removal apparatus **106** having a male connector **108** and a female connector **110**. More particularly, FIGS. 4A-4E sequentially demonstrate a mating process between the male connector **108** and the female connector **110**. In the illustrated example, the male connector **108** includes a first poppet valve **112** positioned between an inlet end of the male connector **108** and a first chamber **114** of the male connector **108**. More particularly, the first poppet valve **112** may include a plunger that is spring loaded against a stationary piece by virtue of a spring **124**. The female connector **110** may include a second poppet valve **116** positioned between an outlet end of the female connector **110** and a second chamber **118** of the female connector **110**, wherein a third poppet valve **120** may be positioned between the second chamber **118** and a third chamber **122** of the female connector **110**. The illustrated third poppet valve **120** includes a plunger that is spring loaded against the outer shell of the female connector **110** (e.g., a stationary piece) by virtue of a spring **126**.

In general, when the inlet end of the female connector **110** is coupled to a source (not shown) of a pressurized substance (e.g., oxygen, hydrogen, nitrogen), the third chamber **122** supplies the second chamber **118** with the pressurized substance during a "charging stage." In this regard, the third poppet valve **120** may include one or more surfaces defining a secondary substance path **128** to supply the second chamber **118** with the pressurized substance during the charging stage. As shown in FIG. 4B, when the second chamber **118** contains the pressurized substance, coupling the male connector **108** to the female connector **110** causes the pressurized substance in the second chamber **118** to clean the inlet end of the male connector **108** (e.g., following the path of the arrows). Moreover, when the second chamber **118** contains

the pressurized substance, decoupling the male connector **108** from the female connector **110** causes the pressurized substance in the second chamber **118** to clean the inlet end of the male connector **108**.

As best shown in FIG. 4E, the third poppet valve **120** includes one or more surfaces defining a primary substance path **130** to supply the male connector **108** with the pressurized substance during a “supply stage” (e.g., following the path of arrows). In one example, the third poppet valve **120** has an actuation force that is greater than the actuation force of the first poppet valve **112** and the second poppet valve **116**. As a result, the illustrated order of activation is the second poppet valve **116** (e.g., as shown in FIG. 4B), then the first poppet valve **112** (e.g., as shown in FIG. 4D), and then third poppet valve **120** (e.g., as shown in FIG. 4E). In general, the second and third chambers **118**, **122** may maintain the transferred substance at a relatively high pressure (e.g., 3800 psi), whereas the first chamber **114** may maintain the transferred substance at a relatively low pressure (e.g., 200 psi).

#### O-Rings

FIGS. 5A and 5B show a debris exclusion and removal apparatus **132** (**132a**, **132b**) in a de-mated configuration (FIG. 5A) and a mated configuration (FIG. 5B). In the illustrated example, a female connector **132a** has a bore **138** (e.g., an elongated configuration) and a male connector **132b** has a shaft **136** (e.g., an elongated configuration) that mates with the bore **138** of the female connector **132a**. A plurality of O-rings **134** (**134a-134c**) may be positioned along either one of the shaft **136** or the bore **138**. The O-rings **134** may generally clean the interior of the apparatus **132** during mating and de-mating, as well as form a longitudinal seal along the apparatus **132** while the male connector **132b** remains coupled to the female connector **132a**. Indeed, the longitudinal seal, which may have a length that is substantially equal to an entire length of the bore **138**, may maintain the interior of the apparatus **132** in a clean state.

In the illustrated example, the plurality of O-rings **134** includes a pair of O-rings **134a**, **134c** positioned at opposing ends of the apparatus **132** and a third O-ring **134b** positioned approximately mid-way between the pair of O-rings **134a**, **134b**. Such a configuration may ensure that at least two of the O-rings **134** engage and wipe the surface being cleaned as the male connector **132b** passes through the female connector **132a**. The illustrated shaft **136** of the male connector **132b** includes a corresponding plurality of grooves in which the plurality of O-rings **134** sit. In such a case, the O-rings **134** clean the bore **138** of the female connector **132a** when the male connector **132b** is either being coupled to or decoupled from the female connector **132a**. Alternatively, the bore **138** of the female connector **132a** may include a corresponding plurality of grooves in which the plurality of O-rings **134** sit, wherein coupling the male connector **132b** to, or decoupling the male connector **132b** from, the female connector **132a** causes the O-rings to clean the shaft **136** of the male connector **132b**.

#### Filament Barriers

FIGS. 6A-6C show debris exclusion and removal apparatuses that may be used to transfer substances and/or electrical current in dusty and/or otherwise unclean environments. For example, FIG. 6A shows an apparatus **140** (**140a**, **140b**) having a first housing **140a** with an open end and a first columnar array of filaments **142** extending across the open end of the first housing **140a**. The first housing **140a** may also include a first connector positioned within the first housing **140a**, wherein the first columnar array of filaments **142** are spaced closely enough together to prevent

dust particles and other debris from reaching the interior of the first housing **140a** and contaminating the first connector (e.g., a clean state).

The illustrated apparatus **140** also includes a second housing **140b** having an open end and a second columnar array of filaments **144** extending across the open end of the second housing **140b**. A second connector may be positioned within the second housing **140b**, wherein an alignment system **146** may arrange the first columnar array of filaments **142** at a non-zero angle (e.g., 90°, 45°, etc.) with respect to the second columnar array of filaments **144** when the first housing **140a** is coupled to the second housing **140b**. Similarly, the second columnar array of filaments **144** may be spaced closely enough together to maintain the interior of the second housing **140b** in a clean state. The first and second columnar arrays of filaments **142**, **144** may be made of any material having an elastic response with no hysteresis (e.g., thread, rubber, TEFLON, etc.). Additionally, more than two arrays of filaments may be used, depending upon the circumstances.

FIG. 6B demonstrates that the first connector may include an electrical connector having one or more pins **148** that are cleaned by the first and second columnar arrays of filaments **142**, **144** when the pins **148** are extended and mated with a corresponding socket **150** in the second housing **140b**. FIG. 6C demonstrates that the first connector may also include a fluid connector (e.g., for liquid and/or gas) having one or more male mating surfaces **152** that are extended and cleaned by the first and second columnar arrays of filaments **142**, **144** after the first housing **140a** is coupled to the second housing **140b** and the one or more male mating surfaces **152** are mated with one or more corresponding female mating surfaces **156** in the second housing **140b**. In either instance, an actuation system **154** may force the pins **148** and/or the male mating surfaces **152** through the first and second columnar arrays of filaments **142**, **144** after the first housing **140a** is coupled to the second housing **140b**. The actuation system **154** may be electrical, mechanical, hydraulic, pneumatic, etc., and may be controlled remotely or locally at the apparatus **140**.

#### Retractable Covers

FIGS. 7A-7H show a debris exclusion and removal apparatus **158** (**158a**, **158b**, e.g., a “blade connector”) that may be used to transfer electrical current in a dusty and/or otherwise unclean environment. In the illustrated example, a first connector **158a** has a male member **160** with a first retractable cover **162** (e.g., spring loaded) positioned about the exterior of the male member **160** (as best shown in FIG. 7G, with the cover forced open). Additionally, a second connector **158b** may include a female member having a second retractable cover **164** (e.g., spring loaded) positioned within the interior of the female member. In one example, an internal dust trapping feature of the illustrated blade connector may be provided against the surfaces perpendicular to the longitudinal axis of the apparatus **158**. More particularly, the internal dust trapping feature may prevent contamination from rapidly propagating throughout the internal mechanisms of the apparatus **158**. Thus, dust does not propagate throughout the apparatus **158** on a first use, in the illustrated example.

The male member **160** may have an outer diameter that is greater than the inner diameter of the second retractable cover **164** so that the male member **160** retracts the second retractable cover **164** when the first and second connectors **158a**, **158b** are coupled to one another. Similarly, the female member may have an inner diameter that is less than the outer diameter of the first retractable cover **162** so that the

female member retracts the first retractable cover **162** when the first and second connectors **158a**, **158b** are coupled to one another. As previously stated, the coupling of the first and second connectors **158a**, **158b** of the apparatus **158** traps (i.e., sandwiches) any dust or other contaminants internally between the mated surfaces of the first and second retractable covers **162**, **164**.

As best shown in FIGS. **7G** and **7H**, the first connector **158a** may include a plurality of wafers **166** positioned along the male member **160**, wherein each wafer may have a non-uniform shape (e.g., winged shape). Moreover, the male member **160** and the second retractable cover **164** may have chamfered cross sections (e.g., best shown in FIG. **7G**, the end view of FIG. **7E**, and FIG. **11A**) that mate with one another (e.g., providing a keyed connection). In such a case, rotation of the first connector **158a** within the second connector **158b** during the coupling process may force the plurality of wafers **166** to protrude from the male member **160**. Additionally, the female member may include a plurality of contacts **168** positioned to align with the plurality of wafers when the first connector **158a** is coupled to the second connector **158b**. Accordingly, the wiping motion between the wafers **166** and the contacts **168** may improve continuity by removing any oxides that may be present.

FIGS. **11A-11D** show a debris exclusion and removal apparatus **230** having a retractable cover configuration according to additional embodiments of the present invention.

#### Additional Embodiments

##### Clamshell End Cap

FIGS. **8A** and **8B** show a debris exclusion and removal apparatus **170** having a clamshell configuration. More particularly, the apparatus **170** may include a housing **172** having an open end and one or more surfaces defining a first cavity to receive a first connector **174**. The illustrated apparatus **170** also includes a first cap segment **176** coupled to the housing **172**, wherein the first cap segment **176** is movable between a first closed position (as shown in FIG. **8A**) in which a first portion (e.g., top half) of the open end is covered by the first cap segment **176** and a first open position in which the first portion of the open end is not covered by the first cap segment **176**. Similarly, a second cap segment **178** may be coupled to the housing **172**, wherein the second cap segment **178** is also movable between a second closed position in which a second portion (e.g., bottom half) of the open end is covered by the second cap segment **178** and a second open position in which the second portion of the open end is not covered by the second cap segment **178**. Thus, placing the cap segments **176**, **178** in their respective closed positions may enable the apparatus **170** to prevent dust and other debris from coming in contact with the connector **174**.

In one example, a first hinge configuration **180** is coupled to the housing **172** and the first cap segment **176**, and a second hinge configuration **182** is coupled to the housing **172** and the second cap segment **178**. Moreover, the apparatus **170** may also include a set of spreader members **184**, wherein each spreader member **184** has a first extremity coupled to the first cap segment **176**, a second extremity coupled to the second cap segment **178**, and a third extremity coupled to the housing **172**. In the illustrated example, each spreader member **184** forms a Y-shape (as shown in FIG. **8B**) when the first cap segment **176** is in the first open position and the second cap segment **178** is in the second

open position. Although only one spreader member **184** is visible in the views shown, the apparatus **170** may include a pair of spreader members **184** positioned on opposite sides of the housing **172**.

Additionally, a set of pins **186** may extend laterally from an exterior of the housing **172**, wherein a rotatable sleeve **188** (e.g., having a large handle) may be coupled to the exterior of the housing **172**. Although only one pin **186** is visible in the views shown, the apparatus **170** may include a pair of pins **186** positioned on opposite sides of the housing **172**. In the illustrated example, each pin **186** is coupled to the rotatable sleeve **188** and one of the third extremities of the spreader members **184**. Moreover, the rotatable sleeve **188** is coupled to the exterior of the housing **172** via a set of rotatable linkage members in the example shown. Thus, rocking the rotatable member **188** forward may cause the cap segments **176**, **178** to part and enable the connector **174** to be mated with another connector (not shown).

In an additional embodiment of the clamshell end cap configuration, an existing off-the-shelf (COTS) connector (e.g., Amphenol® Astronaut Zero-G Connector) is adapted for use in dusty and/or contaminated environments as a debris exclusion and removal apparatus. More specifically the clamshell cap segments **176**, **178** are coupled to an existing COTS connector housing in a manner similar to what has previously been described for the clamshell cap configuration.

#### Additional Embodiments

##### Flip Cap

FIGS. **9A-9D** show a debris exclusion and removal apparatus **190** (FIGS. **9C** and **9D**) having a flip cap configuration. In the illustrated example, a first portion **191a** includes a first housing **194** with an open end and one or more surfaces defining a first cavity to receive a first connector (**201** of FIG. **9D**). In addition, a first cap **192** may be coupled to the first housing **194**, wherein the first cap **192** is movable between a closed position (as shown in FIG. **9A**) in which the open end of the first housing **194** is covered by the first cap **192** and an open position (as shown in FIG. **9B**) in which the open end of the first housing **194** is not covered by the first cap **192**.

A first hinge **196** may also be coupled to the first housing **194** and the first cap **192**, wherein the first hinge **196** inverts the first cap **192** between the closed position and the open position. The illustrated first portion **191a** also includes a first pin **198** extending laterally from the hinge, wherein a side rail **200** may extend longitudinally along the exterior of the first housing **194**. The side rail **200** may have a first end **202** with surfaces defining an L-shaped (e.g., “sliding yoke”) aperture to receive the first pin **198**. Moreover, a multi-axis lever **204** (e.g., a full “lazy tong,” a half “lazy tong,” etc.) may be coupled to the first housing **194** and a second end **206** of the side rail **200**, wherein the multi-axis lever **204** inverts the first cap **192** to the open position when the multi-axis lever **204** is squeezed toward the side rail **200**.

As best shown in FIG. **9C**, a second portion **191b** of the apparatus **190** may also have a second housing **208** with an open end and one or more surfaces defining a second cavity to receive a second connector (**203** of FIG. **9D**). A second cap **210** may be coupled to the second housing **208**, wherein the second cap **210** is movable between a closed position in which the open end of the second housing **208** is covered by the second cap and an open position in which the open end of the second housing **208** is not covered by the second cap

210. The second portion **191b** may also include a pin **198**, side rail **200** and multi-axis lever **204** as already described with regard to the first portion **191a**. Thus, when the open end of the first housing **194** and the open end of the second housing **208** are coupled to one another, the illustrated first and second caps **192**, **210** seal one another. Such a seal may prevent dust and other debris from collecting within the first and second caps **192**, **210**.

Additionally, the open end of the first housing **191a** may include a set of laterally extending protrusions **205** (as best shown in FIG. 9D) that are equi-angularly spaced apart from one another, wherein each protrusion corresponds to a set of apertures **207** in the open end of the second housing **191b**. Furthermore, the protrusions **205** and apertures **207** operate as a cam and groove coupling that locks the first and second housings to one another via rotation. It should also be noted that the two halves (**191a**, **191b**) of the apparatus **190** are mirror images of each other with respect to the hinge **196** location, such that the two hinges, one on each half (**191a**, **191b**) of the apparatus **190**, do not interfere with each other when the two parts of apparatus **190** are rotated and locked together.

#### Additional Embodiments

##### Intelligent Electrical Connector

FIGS. 10A and 10B show an intelligent electrical connector **212** having a miniaturized configuration that is easily maintainable and serviceable (e.g., cable harnesses do not require disconnecting to diagnose conductor faults/damage). In the illustrated example, a housing **214** contains a plurality of conductors **216** (e.g., contacts, pins, sockets, wires, cables) coupled to a first port **218** and a second port **220**. The housing **214** may generally have a small form factor that enables various components of a system to be connected to one another. For example, FIG. 10A demonstrates that the electrical connector **212** might be installed at opposing ends of a cable **226** having a set of conductors to transfer electrical current (e.g., signals and/or power) therebetween. In the illustrated example, a tester **222** is positioned within the housing **214**, wherein the tester **222** may be configured to detect one or more faults associated with one or more of the plurality of conductors **216**. Additionally, a switch matrix **224** may be positioned within the housing **214**, wherein the switch matrix **224** is configured to cure the one or more faults with a re-routing of one or more of the plurality of conductors **216**.

The electrical connector **212** may also include a wireless module **228** coupled to the tester **222** and the switch matrix **224**, wherein the wireless module **228** may transmit notification information associated with the fault to a remote location (e.g., remote processor, server, facility, etc.). In such a case, the wireless module **228** may receive configuration information from the remote location, wherein the switch matrix **224** performs the re-routing based on the configuration information.

The tester **222** and/or the remote location may generally use time domain reflectometry (TDR) to detect open, shorted and intermittent circuits. Moreover, the switch matrix **224** may autonomously transfer damaged/defective conductors to alternate wire paths. The switch matrix **224** may also use interchangeable modular elements such as microelectromechanical systems (MEMS) to perform the re-routing. In a preferred embodiment, the switch matrix should be of the latching type to maintain configuration during power cycles. In one example, the contents of the

housing **214** are integrated onto a common printed circuit board (PCB) (e.g., rigid, flexible), which facilitates miniaturization of the intelligent electrical connector **212**.

One or more of the techniques described herein may be used separately or in combination with one another to enable the safe transfer of electrical current, fluid, and/or gas in harsh environments containing airborne debris as well as debris on the ground and/or floor.

Embodiments may therefore include a debris exclusion and removal apparatus comprising a first housing having an open end and one or more surfaces defining a first cavity to receive a first connector, and a first cap coupled to the first housing, wherein the first cap is movable between a closed position in which the open end of the first housing is covered by the first cap and an open position in which the open end of the first housing is not covered by the first cap.

Embodiments may also include a debris exclusion and removal apparatus comprising a male connector including a first poppet valve positioned between an inlet end of the male connector and a first chamber of the male connector, and a female connector including a second poppet valve positioned between an outlet end of the female connector and a second chamber of the female connector, and a third poppet valve positioned between the second chamber and a third chamber of the female connector, wherein when the second chamber contains a pressurized substance, coupling the male connector to the female connector causes the pressurized substance in the second chamber to clean the inlet end of the male connector.

Embodiments may also include a debris exclusion and removal apparatus comprising a female connector having an elongated configuration, a male connector having an elongated configuration that mates with the elongated configuration of the female connector, and a plurality of O-rings positioned along one of a shaft of the male connector or a bore of the female connector.

Embodiments may also include a debris exclusion and removal apparatus comprising a first housing including an open end and a first columnar array of filaments extending across the open end of the first housing, and a first connector positioned within the first housing.

Embodiments may also include a debris exclusion and removal apparatus, comprising a first connector having a male member with a first retractable cover positioned about an exterior of the male member, and a second connector having a female member with a second retractable cover positioned within an interior of the female member.

The term “coupled” may be used herein to refer to any type of relationship, direct or indirect, between the components in question, and may apply to electrical, mechanical, fluid, optical, electromagnetic, electromechanical or other connections. In addition, the terms “first,” “second,” etc. may be used herein only to facilitate discussion, and carry no particular temporal or chronological significance unless otherwise indicated.

Those skilled in the art will appreciate from the foregoing description that the broad techniques of the embodiments of the present invention can be implemented in a variety of forms. Therefore, while the embodiments of this invention have been described in connection with particular examples thereof, the true scope of the embodiments of the invention should not be so limited since other modifications will become apparent to the skilled practitioner upon a study of the drawings, specification, and following claims.



We claim:

1. A debris exclusion and removal apparatus comprising: a first housing having an open end and one or more surfaces defining a first cavity to receive a first connector;
  - a first cap coupled to the first housing, wherein the first cap is movable between a closed position in which the open end of the first housing is covered by the first cap and an open position in which the open end of the first housing is not covered by the first cap;
  - a second housing having a second cap and an open end and one or more surfaces defining a second cavity to receive a second connector; and
  - a second hinge coupled to the second housing and the second cap, wherein the second hinge inverts the second cap between a closed position and an open position;
- wherein when the open end of the first housing and the open end of the second housing are coupled to one another, the first cap and the second cap seal one another.
2. The apparatus of claim 1, further comprising: a set of pins extending from opposing sides of the first housing and defining an axis, wherein the first cap is coupled to the first housing via the set of pins, and wherein the first cap is rotatable about the axis defined by the set of pins.
  3. The apparatus of claim 1, further comprising: a first handle coupled to the first cap; a second handle coupled to the second cap; and a locking system including an actuation rod extending laterally through a longitudinal slot of the second housing and a rotatable sleeve external to the second housing, the actuation rod being coupled to the second connector and the rotatable sleeve being coupled to the actuation rod.
  4. The apparatus of claim 1, further including: a plurality of side rails coupled to an exterior of the housing, each side rail including one or more surfaces defining a longitudinal slot; and a plurality of dual-member linkages, wherein each dual member linkage rests in a longitudinal slot of a corresponding side rail and forces the first and second caps open when the second housing is mated with the plurality of side rails.
  5. The apparatus of claim 1, further comprising: a first side piece coupled to an external surface of the first housing, wherein the first cap includes a first wiper positioned on an underside of the first cap.
  6. The apparatus of claim 5, wherein the wiper brushes against an external surface of the first side piece as the first cap rotates to the open position.
  7. The apparatus of claim 5, wherein the wiper seals the open end of the housing when the first cap is in the closed position.
  8. The apparatus of claim 1, further comprising: a second housing having an open end that mates with the open end of the first housing and one or more surfaces defining a second cavity to receive a second connector; and a second cap coupled to the second housing, wherein the second cap is rotatable between a closed position in which the open end of the second housing is covered by the second cap and an open position in which the open end of the second housing is not covered by the second cap.
  9. The apparatus of claim 8, further comprising: a second side piece coupled to an external surface of the second housing, wherein the second cap includes a second wiper positioned on an underside of the second cap.
  10. The apparatus of claim 8, further comprising: an actuator assembly having an actuator arm and one or more

surfaces defining a third cavity to receive the first housing and the second housing, wherein the actuator arm is coupled to the first housing and moves the first housing longitudinally within the third cavity during transitions of the first cap between the closed position and the open position.

11. The apparatus of claim 10, further comprising: a first set of pins extending from opposing sides of the first housing, wherein the actuator assembly further includes one or more surfaces defining a plurality of longitudinal slots to receive the first set of pins and guide the first housing longitudinally within the third cavity during transitions of the first cap between the closed position and the open position; and a second set of pins extending from opposing sides of the second housing, wherein the actuator assembly further includes one or more surfaces defining a plurality of stabilizing slots to receive the second set of pins.

12. The apparatus of claim 11, further comprising: a third set of pins extending from opposing sides of the actuator arm, wherein the plurality of longitudinal slots receive the third set of pins and guide the actuator arm longitudinally during transitions of the first cap between the closed position and the open position.

13. The apparatus of claim 1, further comprising: a first hinge coupled to the first housing and the first cap, wherein the first hinge inverts the first cap between the closed position and the open position.

14. The apparatus of claim 13, wherein the first hinge includes a bending tension spring having a shape memory alloy that biases the first cap toward the closed position.

15. The apparatus of claim 13, further comprising: a first multi-axis lever coupled to an external surface of the first housing and the first hinge, the first multi-axis lever to invert the first cap to the open position when the first multi-axis lever is squeezed toward the external surface of the first housing.

16. The apparatus of claim 15, wherein the first multi-axis lever includes a hook at an end of the multi-axis lever and the first cap includes a protrusion at a periphery of the first cap, and wherein the hook engages with the protrusion when the first cap is in the closed position.

17. The apparatus of claim 1, wherein the open end of the first housing and the open end of the second housing have a cam and groove coupling that enables locking of the first and second housings to one another via rotation.

18. The apparatus of claim 17, wherein the rotation causes a friction based removal of contaminants from one or more surfaces of the apparatus.

19. The apparatus of claim 13, further including: a first pin extending laterally from the hinge; a side rail extending longitudinally along an exterior of the first housing, the side rail having a first end with surfaces defining an L-shaped aperture to receive the first pin; and a multi-axis lever coupled to the first housing and a second end of the side rail, the multi-axis lever to invert the first cap to the open position when the multi-axis lever is squeezed toward the side rail.

20. The apparatus of claim 19, further including: a second housing having an open end and one or more surfaces defining a second cavity to receive a second connector; a second cap coupled to the second housing, wherein the second cap is movable between a closed position in which the open end of the second housing is covered by the second cap and an open position in which the open end of the second housing is not covered by the second cap, and wherein when the open end of the first housing and the open end of the

second housing are coupled to one another, the first cap and the second cap seal one another.

\* \* \* \* \*