

US009417046B2

(12) **United States Patent**  
**Steele et al.**

(10) **Patent No.:** **US 9,417,046 B2**  
(45) **Date of Patent:** **\*Aug. 16, 2016**

(54) **TAPE MEASURE**

(71) Applicant: **Milwaukee Electric Tool Corporation**,  
Brookfield, WI (US)

(72) Inventors: **Michael S. Steele**, Waukesha, WI (US);  
**Steven W. Hyma**, Milwaukee, WI (US);  
**Wade F. Burch**, Wauwatosa, WI (US);  
**Cheng Zhang Li**, Sussex, WI (US);  
**Scott R. Fischer**, Menomonee Falls, WI  
(US); **Abhijeet A. Khangar**, Waukesha,  
WI (US)

(73) Assignee: **MILWAUKEE ELECTRIC TOOL  
CORPORATION**, Brookfield, WI (US)

(\*) Notice: Subject to any disclaimer, the term of this  
patent is extended or adjusted under 35  
U.S.C. 154(b) by 59 days.

This patent is subject to a terminal dis-  
claimer.

(21) Appl. No.: **14/463,177**

(22) Filed: **Aug. 19, 2014**

(65) **Prior Publication Data**

US 2014/0352165 A1 Dec. 4, 2014

**Related U.S. Application Data**

(63) Continuation of application No. 13/561,773, filed on  
Jul. 30, 2012, now Pat. No. 8,806,770.

(60) Provisional application No. 61/513,283, filed on Jul.  
29, 2011, provisional application No. 61/607,060,  
filed on Mar. 6, 2012, provisional application No.  
61/656,297, filed on Jun. 6, 2012.

(51) **Int. Cl.**  
**G01B 3/10** (2006.01)

(52) **U.S. Cl.**  
CPC ..... **G01B 3/1041** (2013.01); **G01B 3/1005**  
(2013.01); **G01B 3/1056** (2013.01); **G01B**  
**3/1084** (2013.01); **G01B 2003/102** (2013.01)

(58) **Field of Classification Search**

CPC ..... G01B 3/10; G01B 3/1056; G01B 3/1071;  
G01B 3/1084

USPC ..... 33/759, 760, 761, 768, 769, 770  
See application file for complete search history.

(56) **References Cited**

**U.S. PATENT DOCUMENTS**

14,947 A 5/1856 Buck et al.  
1,303,756 A 5/1919 Ballou

(Continued)

**FOREIGN PATENT DOCUMENTS**

CN 2174684 8/1994  
DE 102006058396 A1 7/2008

(Continued)

**OTHER PUBLICATIONS**

Hyun-Kyu Ko, "A Study on Design of Measure Tape for Home Use  
(for DIY)" (1996) Master's Thesis-Kyung Sung University, Graduate  
School of Industry, Department of Industrial Design, 658.04 4 (81  
pages with English translation).

*Primary Examiner* — G. Bradley Bennett

(74) *Attorney, Agent, or Firm* — Michael Best & Friedrich  
LLP

(57) **ABSTRACT**

A tape measure includes a housing arranged to substantially  
enclose an internal cavity, the housing defining a tape port,  
and a tape positioned partially within the housing, the tape  
including an end portion that extends through the tape port  
and out of the housing. A hook is coupled to the end portion  
and a finger guard assembly is coupled to the housing and  
spaced apart from the tape port. The end portion extends  
through an aperture in the finger guard assembly and is mov-  
able between a retracted position in which the hook abuts the  
finger guard assembly and an extended position in which the  
hook is spaced apart from the finger guard assembly.

**18 Claims, 3 Drawing Sheets**

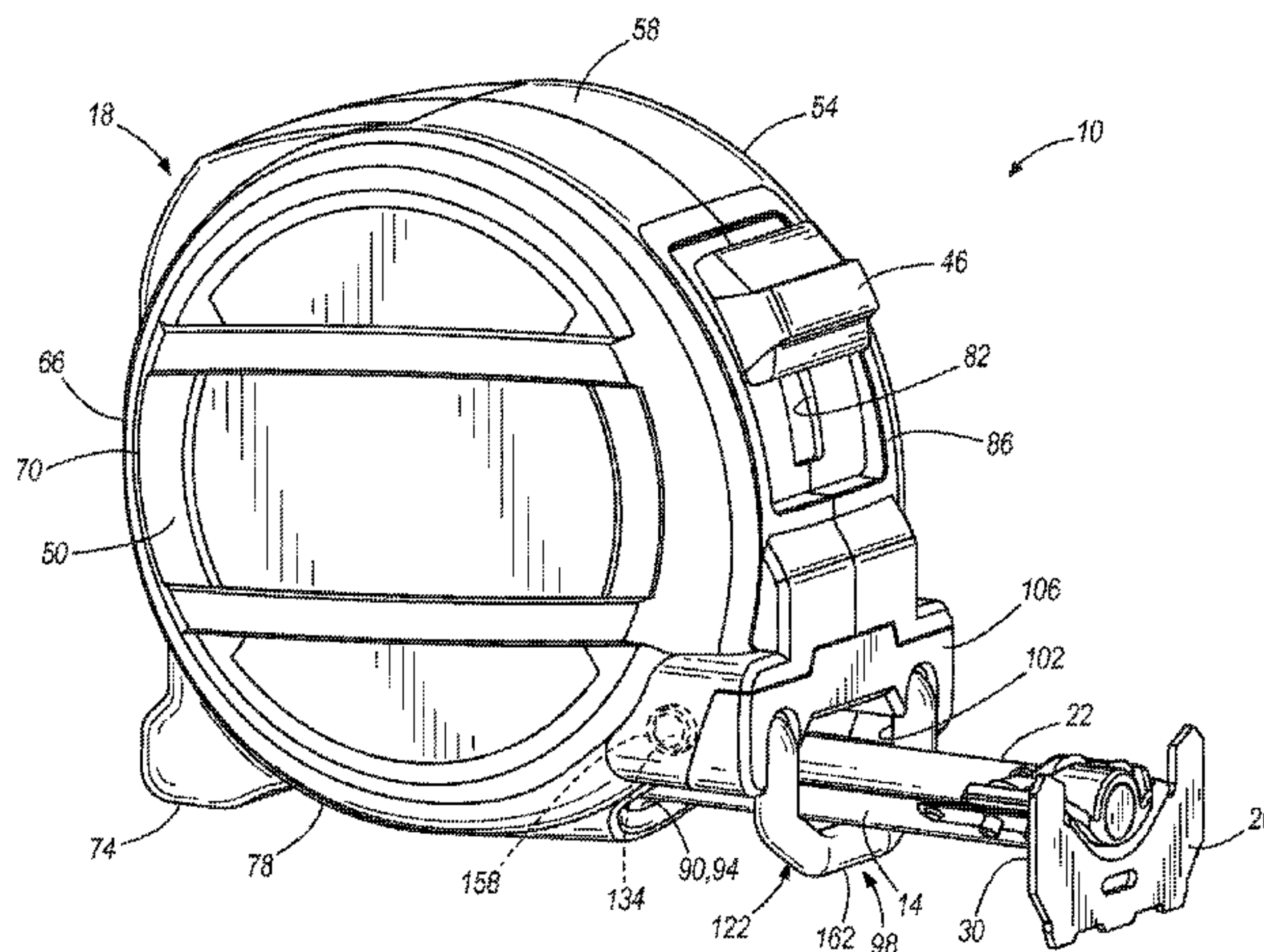

(56)

## References Cited

## U.S. PATENT DOCUMENTS

1,613,676 A	1/1927	Raphael	5,600,894 A	2/1997	Blackman et al.
2,052,259 A	8/1936	Stowell	5,659,970 A	8/1997	Reedy
2,156,905 A	5/1939	Stowell et al.	5,699,623 A	12/1997	Lee
2,574,272 A	11/1951	McCully	5,746,004 A	5/1998	Wertheim
2,614,769 A	10/1952	Nicholson	D396,816 S	8/1998	Kang
2,676,374 A *	4/1954	Ballard .....	D397,304 S	8/1998	Kang
		G01B 3/1071	5,791,581 A	8/1998	Loeffler et al.
		24/265 H	5,794,357 A	8/1998	Gilliam et al.
2,683,933 A	7/1954	McFarland	D397,626 S	9/1998	Davis
2,809,142 A	10/1957	Sellen et al.	D397,950 S	9/1998	Blackman et al.
2,816,369 A	12/1957	Becker	5,806,202 A	9/1998	Blackman et al.
2,994,958 A	8/1961	Beeber	5,809,662 A	9/1998	Skinner
3,100,937 A	8/1963	Burch	5,815,940 A	10/1998	Valentine, Sr.
3,164,907 A	1/1965	Quenot	5,820,057 A	10/1998	Decarolis et al.
3,205,584 A *	9/1965	Overaa .....	5,829,152 A	11/1998	Potter et al.
		G01B 3/1061	D402,216 S	12/1998	Gilliam et al.
		33/760	5,842,284 A	12/1998	Goldman
3,214,836 A	11/1965	West	5,845,412 A	12/1998	Arcand
3,499,225 A	3/1970	Darrah	5,875,557 A	3/1999	Ueki
3,519,219 A	7/1970	Zelnick	5,884,408 A	3/1999	Simmons
3,519,220 A	7/1970	Zelnick	5,894,677 A	4/1999	Hoffman
3,521,831 A	7/1970	Schmidt	5,895,539 A	4/1999	Hsu
3,577,641 A	5/1971	Smith	D409,104 S	5/1999	Yang
3,578,259 A	5/1971	Zelnick	5,913,586 A	6/1999	Marshall
3,601,896 A	8/1971	Ledene	5,922,999 A	7/1999	Yang
3,672,597 A	6/1972	Williamson	D412,858 S	8/1999	Staton
3,713,603 A	1/1973	Shore	5,990,435 A	11/1999	Chao
3,838,520 A	10/1974	Quenot	6,011,472 A	1/2000	Pendergraph et al.
3,874,608 A	4/1975	Quenot	D420,606 S	2/2000	Hsu
4,103,426 A	8/1978	Robin	D421,230 S	2/2000	Gilliam et al.
4,121,785 A	10/1978	Quenot	6,026,585 A	2/2000	Li
4,131,244 A	12/1978	Quenot	6,032,379 A	3/2000	Usami
4,149,320 A	4/1979	Troyer et al.	D423,382 S	4/2000	Piotrkowski
4,164,816 A	8/1979	Bergkvist	6,052,914 A	4/2000	Soon
4,186,490 A	2/1980	Quenot	D424,454 S	5/2000	Ikeda
4,288,923 A	9/1981	Duda	6,082,017 A	7/2000	Simar
4,363,171 A	12/1982	Scandella	6,085,433 A	7/2000	Li
4,433,486 A	2/1984	Muehlenbein	6,098,303 A	8/2000	Vogel
4,462,160 A	7/1984	Cohen	6,108,926 A	8/2000	Fraser et al.
4,476,635 A	10/1984	Hart	6,115,933 A	9/2000	Li
4,479,617 A	10/1984	Edwards	RE36,887 E	10/2000	Goldman
4,489,494 A	12/1984	Duda	6,148,534 A	11/2000	Li
4,516,325 A	5/1985	Cohen et al.	6,161,299 A	12/2000	Lin
4,527,334 A	7/1985	Jones et al.	6,167,635 B1	1/2001	Lin
4,547,969 A	10/1985	Haack	6,178,655 B1	1/2001	Potter et al.
4,603,481 A	8/1986	Cohen et al.	D438,478 S	3/2001	Lin
4,748,746 A	6/1988	Jacoff	D439,531 S	3/2001	Davis et al.
4,811,489 A	3/1989	Walker	6,209,219 B1	4/2001	Wakefield et al.
4,860,901 A	8/1989	Hochreuther et al.	D441,308 S	5/2001	Davis
4,930,227 A	6/1990	Ketchpel	D442,076 S	5/2001	Swanson
4,965,941 A	10/1990	Agostinacci	6,237,243 B1	5/2001	Cook
4,998,356 A	3/1991	Chapin	RE37,212 E	6/2001	Marshall
4,999,924 A	3/1991	Shields	6,243,964 B1	6/2001	Murray
5,010,657 A	4/1991	Knapp	6,249,986 B1	6/2001	Murray
5,038,985 A	8/1991	Chapin	D447,069 S	8/2001	Budrow
5,046,339 A	9/1991	Krell	6,272,764 B1	8/2001	Lin
5,062,215 A	11/1991	Schlitt	6,276,071 B1	8/2001	Khachatoorian
5,134,784 A	8/1992	Atienza	D447,712 S	9/2001	Hsu
D333,628 S	3/1993	Piotrkowski	6,282,808 B1	9/2001	Murray
5,189,801 A	3/1993	Nicely	6,308,432 B1	10/2001	Gilliam et al.
5,208,767 A	5/1993	George-Kelso et al.	D451,041 S	11/2001	Chen
5,210,956 A	5/1993	Knispel et al.	6,324,769 B1	12/2001	Murray
5,230,158 A	7/1993	Wall	6,338,204 B1	1/2002	Howle
D342,210 S	12/1993	Grossman	D453,303 S	2/2002	Lin
D342,459 S	12/1993	Shen	6,349,482 B1	2/2002	Gilliam
D342,687 S	12/1993	Kang	6,367,161 B1	4/2002	Murray et al.
5,335,421 A	8/1994	Jones, Jr.	D458,163 S	6/2002	Kang
D350,703 S	9/1994	Fifer	D458,550 S	6/2002	Hsu
5,367,785 A	11/1994	Benarroch	6,431,486 B1	8/2002	Lee
5,448,837 A	9/1995	Han-Teng	D463,300 S	9/2002	Li
D365,769 S	1/1996	Kang	6,442,863 B1	9/2002	Poineau et al.
5,481,813 A	1/1996	Templeton	6,449,866 B1	9/2002	Murray
5,506,378 A	4/1996	Goldenberg	D464,277 S	10/2002	Tarver, III
5,531,395 A	7/1996	Hsu	D464,579 S	10/2002	Martone
5,542,184 A	8/1996	Beard	6,470,582 B1	10/2002	Renko
D375,269 S	11/1996	Wertheim et al.	6,470,590 B1	10/2002	Lee
5,575,077 A	11/1996	Jung Tae	6,490,809 B1	12/2002	Li
			6,497,050 B1	12/2002	Ricalde
			6,499,226 B1	12/2002	Reda et al.



(56)

References Cited

U.S. PATENT DOCUMENTS

D469,704 S	2/2003	Williams et al.	D557,155 S	12/2007	Sa'ar
RE38,032 E	3/2003	Butwin	D558,620 S	1/2008	Critelli et al.
D471,473 S	3/2003	Blackman et al.	D560,522 S	1/2008	Farnworth et al.
D471,827 S	3/2003	Ranieri et al.	7,334,344 B2	2/2008	Scarborough
6,530,159 B2	3/2003	Tarver, III	7,343,694 B2	3/2008	Erdfarb
6,543,144 B1	4/2003	Morin	D565,441 S	4/2008	Critelli
6,546,644 B2	4/2003	Poineau et al.	D565,442 S	4/2008	Critelli
D474,412 S	5/2003	Ichinose et al.	7,363,723 B1	4/2008	Peterson
6,568,099 B2	5/2003	Bergeron	7,377,050 B2	5/2008	Shute et al.
D476,913 S	7/2003	Blackman et al.	7,398,604 B2	7/2008	Murray
6,595,451 B1	7/2003	Kang et al.	7,406,778 B2	8/2008	Lee et al.
6,598,310 B1	7/2003	Odachowski	7,415,777 B2	8/2008	Campbell et al.
6,637,124 B2	10/2003	Pederson	7,415,778 B1	8/2008	McEwan et al.
6,637,126 B2	10/2003	Balota	D579,359 S	10/2008	Critelli et al.
6,643,947 B2	11/2003	Murray	7,434,330 B2	10/2008	McEwan et al.
D485,770 S	1/2004	Lee	7,454,845 B2	11/2008	Wise
D486,086 S	2/2004	Jueneman	D582,810 S	12/2008	Cook
6,684,522 B2	2/2004	Chilton	7,458,537 B2	12/2008	Critelli et al.
6,688,010 B1	2/2004	Schwaerzler	7,475,842 B2	1/2009	Campbell
6,691,426 B1	2/2004	Lee et al.	7,487,600 B1	2/2009	Cooper
6,694,622 B2	2/2004	Kim	7,490,414 B2	2/2009	Critelli et al.
6,698,679 B1	3/2004	Critelli et al.	7,490,415 B1	2/2009	Cubbedge
6,718,649 B1	4/2004	Critelli et al.	D590,283 S	4/2009	Critelli et al.
6,760,979 B1	7/2004	Hsu	D590,284 S	4/2009	Critelli et al.
6,796,052 B1	9/2004	Lin	7,555,845 B2	7/2009	Critelli et al.
6,804,899 B2	10/2004	Murray	7,559,154 B2	7/2009	Levine et al.
6,811,109 B1	11/2004	Blackman et al.	7,565,751 B2	7/2009	Murray
6,836,975 B2	1/2005	Lin	7,594,341 B2	9/2009	Erdfarb
6,839,981 B2	1/2005	Rafter	D603,248 S	11/2009	Bar-Erez
6,854,197 B2	2/2005	Knight	7,617,616 B1	11/2009	Berg
D503,351 S	3/2005	Chen	7,627,958 B2	12/2009	Tallon et al.
D503,637 S	4/2005	Noel	7,631,437 B2	12/2009	Sanderson
D503,897 S	4/2005	Lin	D611,849 S	3/2010	Cook et al.
6,874,245 B2	4/2005	Liu	7,669,347 B1	3/2010	Huang
D504,628 S	5/2005	Weeks et al.	D613,629 S	4/2010	Suzuki
D504,835 S	5/2005	Snider	D614,516 S	4/2010	Capra
D504,836 S	5/2005	Wang	7,703,216 B2	4/2010	Huang
6,892,468 B2	5/2005	Murray	D617,224 S	6/2010	Delneo et al.
6,904,697 B2	6/2005	Zars	7,805,855 B2	10/2010	Seo
D507,195 S	7/2005	Kondo et al.	7,845,093 B2	12/2010	Smiroldo
6,918,191 B2	7/2005	Stauffer et al.	7,846,673 B2	12/2010	Pastorek et al.
6,920,700 B2	7/2005	Ekdahl et al.	7,854,074 B2	12/2010	Zhou
6,931,734 B2	8/2005	Elder et al.	7,913,406 B2	3/2011	Norelli
6,931,753 B2	8/2005	Ryals et al.	7,918,037 B1	4/2011	Polkhovskiy
6,935,045 B2	8/2005	Cubbedge	7,987,611 B2	8/2011	Taylor
6,938,354 B2	9/2005	Worthington	8,015,723 B2	9/2011	Solomon
6,944,961 B2	9/2005	Carroll	8,056,849 B2	11/2011	Ng et al.
6,959,499 B2	11/2005	Bini	8,081,815 B2	12/2011	Kotake
6,962,002 B2	11/2005	Panosian	D653,974 S	2/2012	Capra
D514,962 S	2/2006	Armendariz	8,117,762 B2	2/2012	Delneo et al.
6,996,915 B2	2/2006	Ricalde	8,117,763 B2	2/2012	Delneo et al.
7,024,791 B2	4/2006	Marshall et al.	D660,735 S	5/2012	Petrillo
D522,890 S	6/2006	Huang	8,215,027 B2	7/2012	Kang
7,055,260 B1	6/2006	Hoffman	8,375,595 B2	2/2013	Murray et al.
7,057,484 B2	6/2006	Gilmore	8,381,411 B2	2/2013	Delarosa et al.
7,059,061 B2	6/2006	French	8,407,909 B2	4/2013	Lindsay
7,086,174 B2	8/2006	Scarborough	8,468,710 B1 *	6/2013	Mos ..... G01B 3/1084 33/668
7,131,214 B1	11/2006	Blackman et al.	8,898,922 B2	12/2014	Bridges et al.
7,131,215 B2	11/2006	Kang	2001/0003872 A1	6/2001	Pederson
D535,900 S	1/2007	McKinney	2001/0042315 A1	11/2001	Dixon
7,159,331 B2	1/2007	Critelli et al.	2002/0011008 A1	1/2002	Nelson et al.
7,168,182 B2	1/2007	Kilpatrick et al.	2002/0066193 A1	6/2002	Hodge
7,174,655 B1	2/2007	Gibbons et al.	2002/0066774 A1	6/2002	Prochac
7,174,656 B1	2/2007	Smith	2002/0073570 A1	6/2002	Conder
7,178,257 B2	2/2007	Kang et al.	2003/0009899 A1	1/2003	Ha
7,185,446 B1	3/2007	King	2003/0019116 A1	1/2003	DeWall
D540,207 S	4/2007	Ikeda et al.	2003/0019123 A1	1/2003	Lin
7,234,246 B1	6/2007	Rhead	2003/0070315 A1	4/2003	Bergeron
RE39,719 E	7/2007	Murray	2003/0213141 A1	11/2003	Lin
D545,701 S	7/2007	Cooper	2003/0233762 A1	12/2003	Blackman et al.
D547,681 S	7/2007	Nelson et al.	2004/0044438 A1	3/2004	Lorraine et al.
7,240,439 B2	7/2007	Critelli et al.	2004/0055174 A1	3/2004	Hirsch, Jr.
7,266,905 B1	9/2007	Lee	2004/0071869 A1	4/2004	Gilliam et al.
7,284,339 B1	10/2007	Campbell et al.	2004/0088875 A1	5/2004	Lee et al.
7,299,565 B2	11/2007	Marshall et al.	2004/0163267 A1	8/2004	Bini
			2004/0163271 A1	8/2004	Zars
			2004/0163272 A1	8/2004	Knight
			2005/0005470 A1	1/2005	Snider

(56)

References Cited

U.S. PATENT DOCUMENTS

2005/0028396 A1 2/2005 Stauffer et al.  
 2005/0155244 A1 7/2005 Ryals et al.  
 2005/0155245 A1 7/2005 Panosian  
 2005/0252020 A1 11/2005 Critelli et al.  
 2005/0252021 A1 11/2005 Kang  
 2006/0005417 A1 1/2006 Rhead  
 2006/0010705 A1 1/2006 Dettellis  
 2006/0096112 A1 5/2006 Berring  
 2006/0096113 A1 5/2006 Kang et al.  
 2006/0107546 A1 5/2006 Pritchard  
 2006/0112582 A1 6/2006 Scarborough  
 2006/0130352 A1 6/2006 Huang  
 2006/0185185 A1 8/2006 Scarborough  
 2006/0230627 A1 10/2006 Blackman et al.  
 2006/0248742 A1 11/2006 Marshall et al.  
 2006/0283036 A1 12/2006 Huang  
 2007/0017111 A1 1/2007 Hoback et al.  
 2007/0056182 A1 3/2007 Di Bitonto et al.  
 2007/0079520 A1 4/2007 Levine et al.  
 2007/0152091 A1 7/2007 Campbell  
 2007/0171630 A1 7/2007 Gibbons et al.  
 2007/0227028 A1 10/2007 Campbell et al.  
 2008/0028628 A1 2/2008 Campbell et al.  
 2008/0086902 A1 4/2008 Murray  
 2008/0086903 A1 4/2008 Peterson  
 2008/0086904 A1 4/2008 Murray  
 2008/0098610 A1\* 5/2008 Lipps ..... G01B 3/1084  
 33/770  
 2008/0168674 A1\* 7/2008 Nielson ..... G01B 3/10  
 33/765  
 2008/0285854 A1 11/2008 Kotake et al.  
 2009/0064517 A1 3/2009 Sanderson  
 2009/0064525 A1 3/2009 Chen  
 2009/0064526 A1 3/2009 Farnworth et al.  
 2009/0249636 A1 10/2009 Reda et al.  
 2010/0139110 A1 6/2010 Germain  
 2010/0314277 A1 12/2010 Murray  
 2010/0325910 A1 12/2010 Huang  
 2011/0005094 A1 1/2011 Solomon  
 2011/0138642 A1 6/2011 Norelli  
 2011/0179661 A1 7/2011 Delneo et al.  
 2011/0179663 A1 7/2011 Kang

2011/0179664 A1 7/2011 Delneo et al.  
 2012/0036727 A1 2/2012 McCarthy  
 2012/0055038 A1 3/2012 Lindsay  
 2012/0073156 A1 3/2012 DeLaRosa et al.  
 2012/0159799 A1 6/2012 Murray et al.  
 2012/0167403 A1 7/2012 Roeske  
 2012/0240419 A1\* 9/2012 Wagner ..... B43L 7/12  
 33/275 R  
 2013/0025147 A1 1/2013 Steele et al.  
 2013/0047455 A1 2/2013 Steele et al.  
 2013/0185949 A1 7/2013 Burch et al.  
 2013/0298417 A1\* 11/2013 Huang ..... G01B 3/1056  
 33/758  
 2015/0047216 A1\* 2/2015 Burch ..... G01B 3/1056  
 33/770  
 2015/0268024 A1\* 9/2015 Brossard ..... G01B 3/1082  
 33/760

FOREIGN PATENT DOCUMENTS

DE 102006058396 B4 6/2011  
 EP 66322 10/1986  
 EP 531570 3/1993  
 EP 427932 2/1996  
 EP 0724133 7/1996  
 EP 0896200 A2 2/1999  
 EP 0896200 A3 12/1999  
 EP 1175840 1/2002  
 EP 1411319 4/2004  
 EP 1144947 9/2004  
 EP 1237431 10/2006  
 EP 2469218 6/2012  
 GB 690458 4/1953  
 JP 1961002384 2/1961  
 JP 1983134704 9/1983  
 JP 10332301 12/1998  
 KR 19840001901 9/1984  
 KR 19910004712 11/1991  
 WO WO 9402799 2/1994  
 WO WO 9714541 4/1997  
 WO WO 9811402 3/1998  
 WO WO 0060306 10/2000  
 WO WO 02057710 7/2002

\* cited by examiner



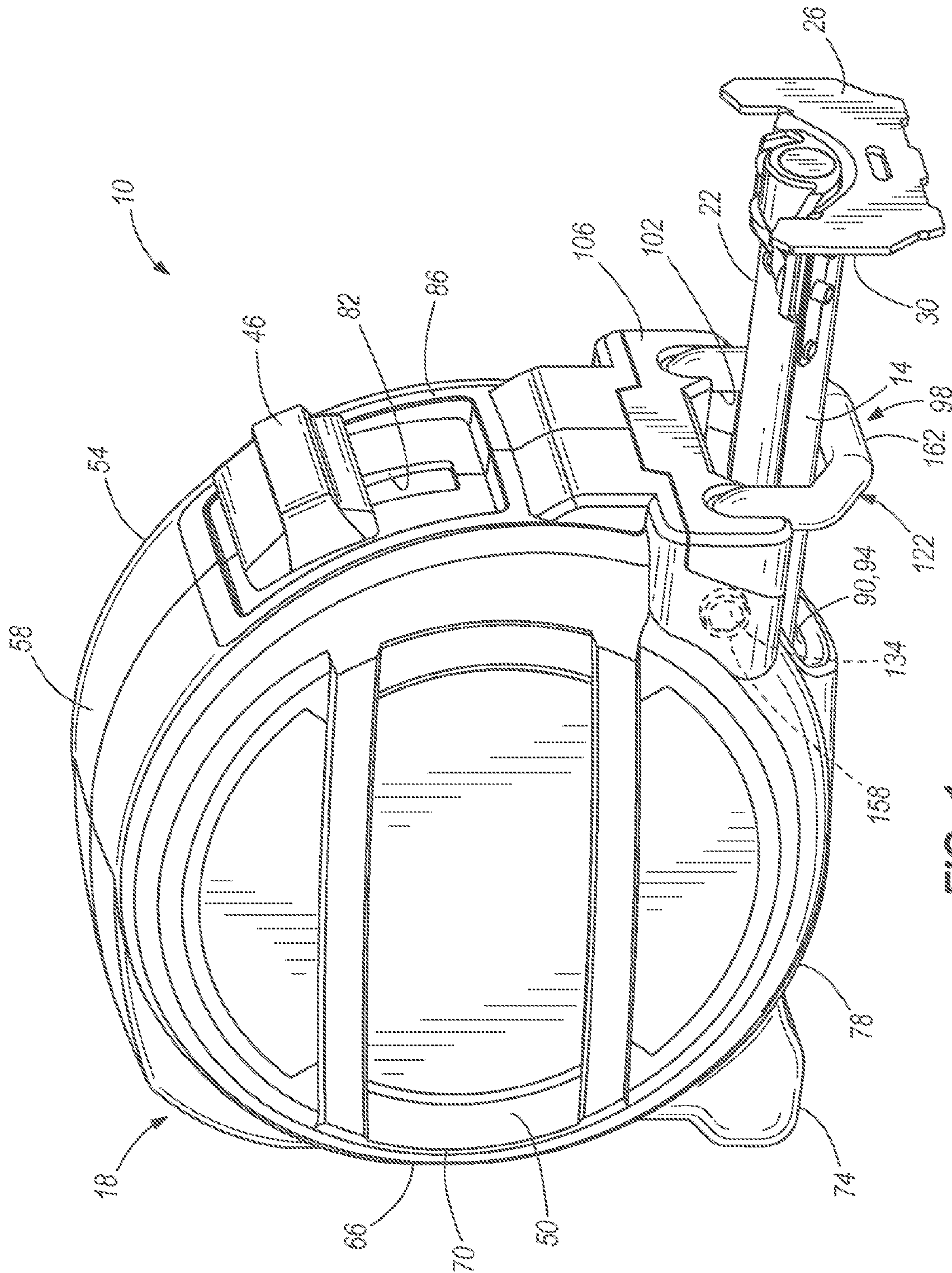
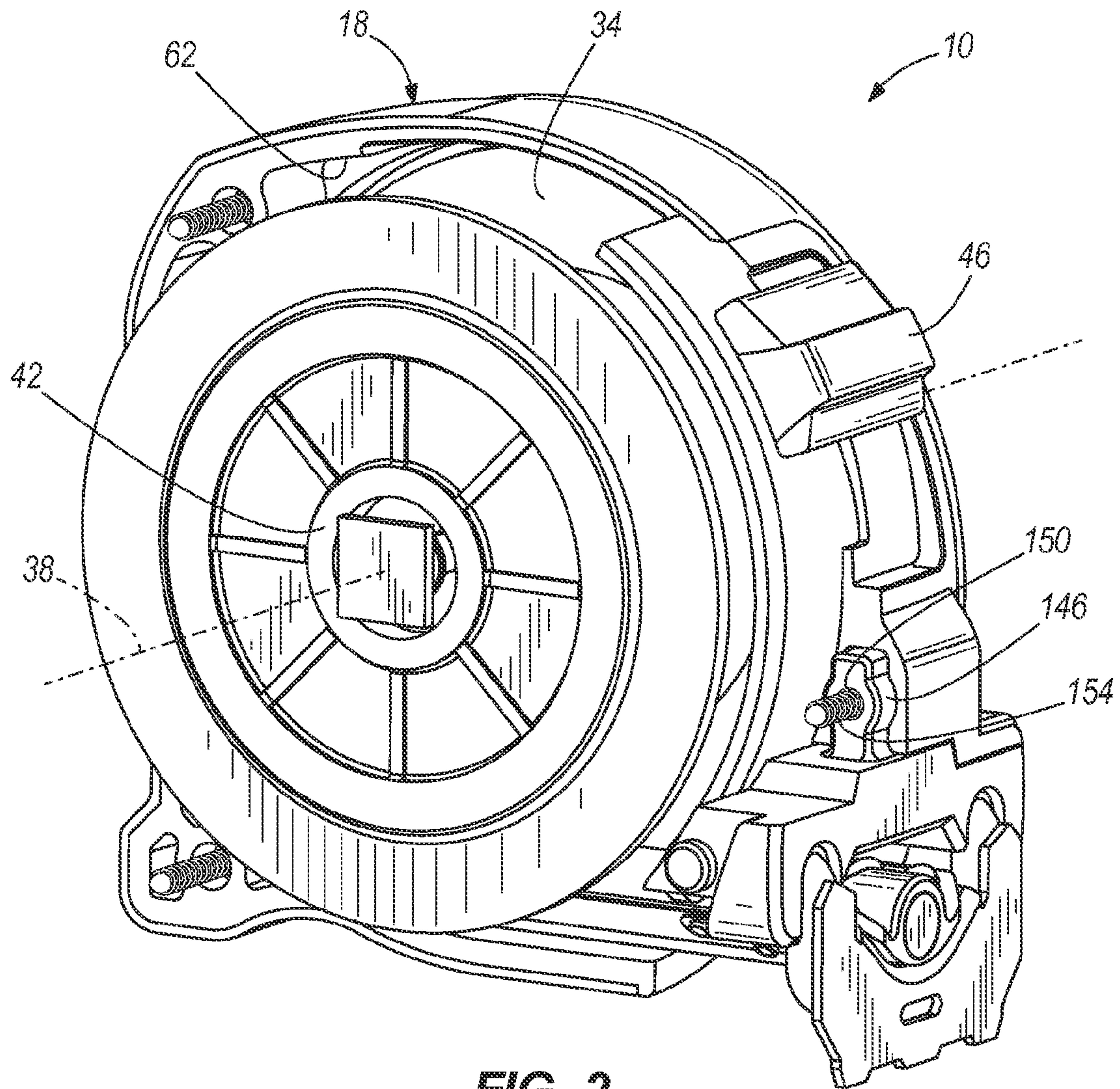

FIG. 1



**FIG. 2**



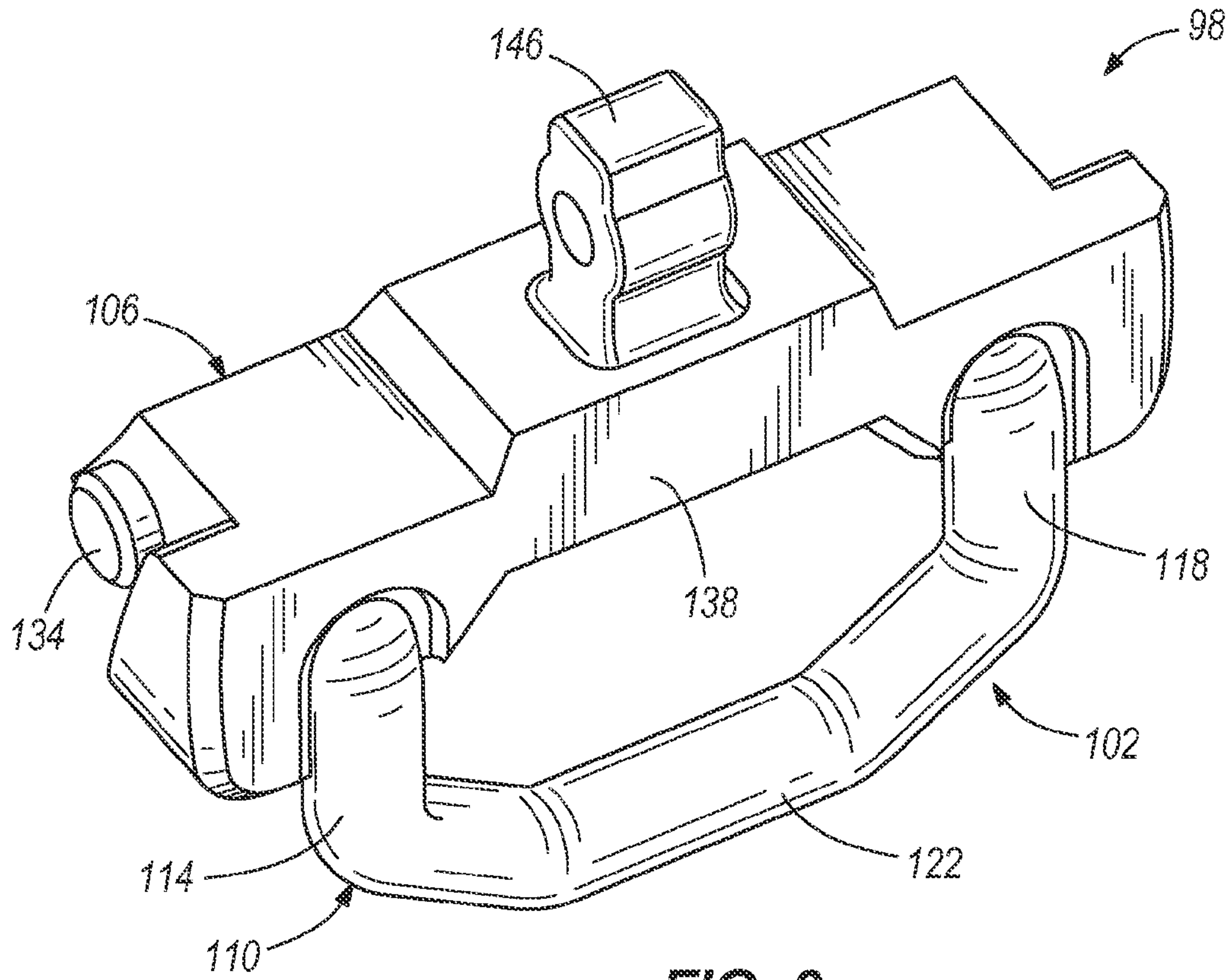

FIG. 3

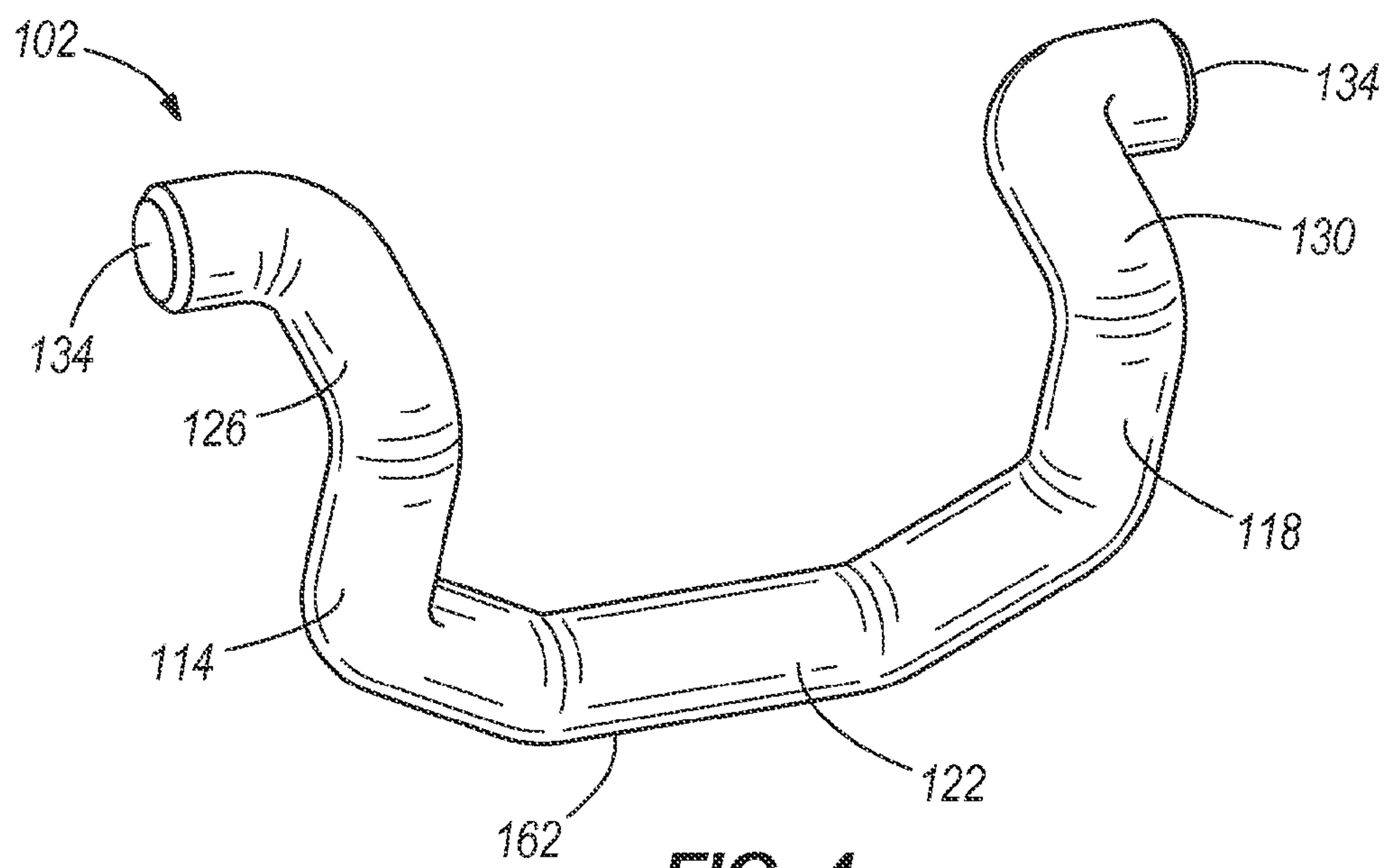

FIG. 4



# 1

## TAPE MEASURE

### CROSS-REFERENCE TO RELATED APPLICATIONS

This application claims priority to U.S. application Ser. No. 13/561,773 filed Jul. 30, 2012, now U.S. Pat. No. 8,806,770, which claims priority to U.S. Provisional Patent Application No. 61/513,283, filed on Jul. 29, 2011, U.S. Provisional Patent Application No. 61/607,060, filed on Mar. 6, 2012, and U.S. Provisional Patent Application No. 61/656,297, filed on Jun. 6, 2012, the entire contents of which are incorporated by reference herein.

### BACKGROUND

The present invention relates to measurement devices, and in particular, the invention relates to a tape measure, and more specifically, a tape measure with a guard member.

### SUMMARY

In one embodiment, the invention provides a tape measure. The tape measure includes a housing assembly defining a cavity and a tape port from which to extend and retract a measuring tape. The measuring tape forms a spool rotatably coupled about an axis. A hook member is fixedly coupled to an end portion of the measuring tape. A U-shaped guard member extends from the housing assembly adjacent the tape port. The guard member is configured to engage the hook member when the measuring tape is retracted into the housing assembly.

In another embodiment, the invention provides a tape measure. The tape measure includes a housing assembly defining a cavity and a tape port from which to extend and retract a measuring tape. The measuring tape forms a spool rotatably coupled about an axis. A hook member is fixedly coupled to an end portion of the measuring tape. A finger guard assembly extends from the housing assembly adjacent the tape port. The finger guard assembly includes a U-shaped guard member and a guard support member and is configured to engage the hook member when the measuring tape is retracted into the housing assembly.

In another construction, the invention provides a tape measure that includes a housing arranged to substantially enclose an internal cavity, the housing defining a tape port, and a tape positioned partially within the housing, the tape including an end portion that extends through the tape port and out of the housing. A hook is coupled to the end portion and a finger guard assembly is coupled to the housing and spaced apart from the tape port. The end portion extends through an aperture in the finger guard assembly and is movable between a retracted position in which the hook abuts the finger guard assembly and an extended position in which the hook is spaced apart from the finger guard assembly.

In another construction, the invention provides a tape measure that includes a housing arranged to substantially enclose an internal cavity, the housing defining a tape port and a finger guard assembly coupled to the housing and cooperating with the housing to define a finger gap. A tape is positioned partially within the housing and includes an end portion. The tape extends through the tape port, through the finger gap, and through an aperture in the finger guard assembly. A hook is coupled to the end portion and is operable to contact the finger guard assembly to inhibit retraction of the end portion past the finger guard assembly and into the finger gap.

# 2

In another construction, the invention provides a tape measure that includes a housing arranged to substantially enclose an internal cavity, the housing defining a tape port, and a finger guard assembly coupled to the housing and defining an opening. A tape is at least partially disposed within the housing. The tape is movable from a retracted position to an extended position by passing substantially linearly through the tape port and the opening. A finger gap is defined between the tape port and the finger guard, wherein a portion of tape within the finger gap is disposed outside of the housing.

Other aspects of the invention will become apparent by consideration of the detailed description and accompanying drawings.

### BRIEF DESCRIPTION OF THE DRAWINGS

FIG. 1 is a perspective view of a tape measure according to one construction of the invention.

FIG. 2 is a perspective view of the tape measure of FIG. 1 with a first side wall removed.

FIG. 3 is a perspective view of a finger guard assembly of the tape measure of FIG. 1.

FIG. 4 is a perspective view of a finger guard of the finger guard assembly of FIG. 3.

### DETAILED DESCRIPTION

Before any constructions of the invention are explained in detail, it is to be understood that the invention is not limited in its application to the details of construction and the arrangement of components set forth in the following description or illustrated in the following drawings. The invention is capable of other constructions and of being practiced or of being carried out in various ways.

FIGS. 1 and 2 illustrate a length measurement device, more specifically, a tape measure 10. The tape measure 10 includes a coilable measuring tape 14 and a housing assembly 18.

As illustrated in FIG. 1, a variable-length extended segment 22 of the measuring tape 14 is retractable and extendable from the housing assembly 18. A hook member 26 is fixedly coupled to an end portion 30 of the measuring tape 14. The remainder of the measuring tape 14 forms a spool 34 rotatably disposed about an axis 38 of the tape measure 10 (FIG. 2). As shown in FIG. 2, a retraction mechanism 42 is coupled to the spool 34 to provide for powered retraction of the measuring tape 14. The retraction mechanism 42 may include an elongated coiled spring for motive force. A tape lock 46 is provided to selectively engage measuring tape 14, such that the extended segment 22 of the measuring tape 14 remains at a desired length.

Referring to FIG. 1, the housing assembly 18 includes a first side wall 50, a second side wall 54, and a peripheral wall 58 connecting the first side wall 50 and the second side wall 54. The first side wall 50, second side wall 54, and peripheral wall 58 define an internal cavity 62 (FIG. 2) in which the spool 34 and retraction mechanism 42 are housed. Referring to FIG. 1, each of the first side wall 50 and the second side wall 54 has a substantially circular profile 66. In other embodiments, the side walls may be rectangular, polygonal, or any other desired shape. Portions of the housing assembly 18 may be co-molded or separately formed of a resilient material, such as a natural or synthetic rubber. In the illustrated construction, the housing assembly 18 is formed with housing bumpers 70 and a support leg 74 which extends from a lower portion 78 of the peripheral wall 58.



## 3

A slot **82** is defined along a forward portion **86** of the peripheral wall **58**. The slot **82** is provided to allow for sliding movement of the tape lock **46** relative to housing assembly **18**.

Below the slot **82**, a tape port **90** is provided in the peripheral wall **58**. The tape port **90** has an arcuate shape **94**, corresponding to an arcuate cross-sectional profile of the measuring tape **14**. The tape port **90** allows for the retraction and extension of the measuring tape **14** to and from the internal cavity **62** (FIG. 2).

As shown in FIGS. 1 and 2, the tape measure includes a finger guard assembly **98**. Referring to FIG. 3, the finger guard assembly **98** includes a guard member **102** and a guard support member **106**. Exposed portions **110** of the guard member **102** are substantially U-shaped, with a first leg **114** and a second leg **118** extending from the guard support member **106**, and a connecting leg **122** extending between the first leg **114** and the second leg **118**.

Referring to FIG. 4, a first mounting extension **126** is coupled to the first leg **114**, and a second mounting extension **130** is coupled to the second leg **118**. Each of the first mounting extension **126** and the second mounting extension **130** includes a mounting boss **134**. The guard member **102** may be formed of substantially rigid material such as a metal and is preferably coated or covered with a resilient material such as rubber or plastic. In other constructions, a resilient polymer or other material is used to form the guard member **102**.

Referring to FIG. 3, the guard support member **106** is molded over the first mounting extension **126** and the second mounting extension **130** of the guard member **102**, such that the exposed portions **110** of the guard member **102** extend from a forward surface **138** of the guard support member **106**. The mounting bosses **134** extend outwardly from lateral edges **142** of the guard support member **106**. In other constructions, other methods are used to connect the guard support member **106** and the guard member **102** (e.g., thermal bonding, adhesives, fasteners, etc.).

The guard support member **106** further includes a fastener boss **146**. Referring to FIG. 2, the fastener boss **146** defines an aperture **150** for receiving a fastener **154** for coupling the guard support member **106** to the housing assembly **18**. The boss **134** of each mounting extension **126** and **130** of the guard member **102** are received by corresponding recesses **158** (FIG. 1) formed in the housing assembly **18**. The guard support member **106** may be formed of a resilient polymer or rubber material, such that the guard support member **106** provides a degree of impact resistance between the guard member **102** and the housing assembly **18** when the guard member **102** is struck by the hook member **26** or the tape measure **10** is dropped upon the guard member **102**. Additionally, the guard support member **106** can rotate relative to the housing assembly **18** about the fastener **154** (FIG. 2) when an impact is received by the guard member **102**.

Referring to FIG. 4, the guard member **102**, and more specifically the connecting leg **122**, is configured to engage the hook member **26** when the measuring tape **14** is fully retracted into the internal cavity **62** (FIG. 1). The guard member **102** also shields the housing assembly **18** from being struck by the hook member **26**. In addition, a lower surface **162** of the guard member **102** is substantially aligned with the support leg **74**, thereby allowing the tape measure **10** to stand upright on a surface to be measured as shown in FIG. 1.

Thus, the invention provides, among other things, a tape measure and more specifically a tape measure with a guard member. Although the invention has been described in detail with reference to certain preferred embodiments, variations

## 4

and modifications exist within the scope and spirit of one or more independent aspects of the invention as described.

The invention claimed is:

1. A tape measure comprising:

- a housing arranged to substantially enclose an internal cavity, the housing defining a tape port;
- a tape positioned partially within the housing, the tape including an end portion that extends through the tape port and out of the housing;
- a hook coupled to the end portion; and
- a finger guard assembly coupled to the housing and spaced apart from the tape port, the end portion extending through an aperture in the finger guard assembly and movable between a retracted position in which the hook abuts the finger guard assembly and an extended position in which the hook is spaced apart from the finger guard assembly.

2. The tape measure of claim 1, further comprising a spool disposed within the housing and operable to support the tape within the housing when the tape is in the retracted position.

3. The tape measure of claim 1, wherein the housing defines a front surface and a bottom portion, and wherein the tape port is formed in the bottom portion and is spaced apart from the front surface.

4. The tape measure of claim 3, wherein the finger guard assembly includes a portion that is substantially flush with the front face.

5. The tape measure of claim 3, wherein the front face and the bottom portion cooperate to define a recessed corner portion between the tape port and the finger guard assembly.

6. The tape measure of claim 1, wherein the tape is outside of the housing when disposed between the tape port and the finger guard assembly.

7. A tape measure comprising:

- a housing arranged to substantially enclose an internal cavity, the housing defining a tape port;
- a finger guard assembly coupled to the housing and cooperating with the housing to define a finger gap;
- a tape positioned partially within the housing, the tape including an end portion, the tape extending through the tape port, through the finger gap, and through an aperture in the finger guard assembly; and
- a hook coupled to the end portion and operable to contact the finger guard assembly to inhibit retraction of the end portion past the finger guard assembly and into the finger gap.

8. The tape measure of claim 7, further comprising a spool disposed within the housing and operable to support the tape within the housing when the tape is in the retracted position.

9. The tape measure of claim 7, wherein the housing defines a front surface and a bottom portion, and wherein the tape port is formed in the bottom portion and is spaced apart from the front surface.

10. The tape measure of claim 9, wherein the finger guard assembly includes a portion that is substantially flush with the front face.

11. The tape measure of claim 9, wherein the front face and the bottom portion cooperate to define the finger gap between the tape port and the finger guard assembly.

12. The tape measure of claim 7, wherein the tape is outside of the housing when disposed between the tape port and the finger guard assembly.

13. A tape measure comprising:

- a housing arranged to substantially enclose an internal cavity, the housing defining a tape port;
- a finger guard assembly coupled to the housing and defining an opening;

a tape at least partially disposed within the housing, the tape movable from a retracted position to an extended position by passing substantially linearly through the tape port and the opening; and

a finger gap defined between the tape port and the finger guard, wherein a portion of tape within the finger gap is disposed outside of the housing.

**14.** The tape measure of claim **13**, further comprising a spool disposed within the housing and operable to support the tape within the housing when the tape is in the retracted position.

**15.** The tape measure of claim **13**, wherein the housing defines a front surface and a bottom portion, and wherein the tape port is formed in the bottom portion and is spaced apart from the front surface.

**16.** The tape measure of claim **15**, wherein the finger guard assembly includes a portion that is substantially flush with the front face.

**17.** The tape measure of claim **15**, wherein the front face and the bottom portion cooperate to define the finger gap between the tape port and the finger guard assembly.

**18.** The tape measure of claim **13**, further comprising a hook coupled to the end portion and operable to contact the finger guard assembly to inhibit retraction of the end portion past the finger guard assembly and into the finger gap.

\* \* \* \* \*