



US009408592B2

(12) **United States Patent**  
**Shabaz et al.**

(10) **Patent No.:** **US 9,408,592 B2**  
(45) **Date of Patent:** **Aug. 9, 2016**

(54) **BIOPSY DEVICE WITH APERTURE ORIENTATION AND IMPROVED TIP**

USPC ..... 600/652, 564, 570, 566, 567; 606/167, 606/185

See application file for complete search history.

(75) Inventors: **Martin V. Shabaz**, Lake Forest, CA (US); **Richard L. Quick**, Mission Viejo, CA (US); **Frank R. Louw**, Carlsbad, CA (US); **Paul Lubock**, Monarch Beach, CA (US); **Jason H. Safabash**, Alison Viejo, CA (US)

(56) **References Cited**

U.S. PATENT DOCUMENTS

2,032,860 A 3/1936 Wappler et al.  
2,192,270 A 3/1940 McGowan

(Continued)

FOREIGN PATENT DOCUMENTS

DE 12 25 813 9/1966  
DE 19528440 A1 8/1995

(Continued)

OTHER PUBLICATIONS

Timothy L. Micklos, *Percutaneous Biopsy Techniques, Manual of Oncologic Therapeutics* (1989/1990), pp. 39-42.

(Continued)

*Primary Examiner* — Rene Towa

(57) **ABSTRACT**

The invention is directed to a system and device for separating and collecting a tissue specimen from a target site within a patient. The device includes a probe component which is releasably secured to the driver component. The probe component has an elongated tubular section, a penetrating distal tip and a tissue receiving aperture in the distal end of the tubular section proximal to the distal tip, and a tissue cutting member which is slidably disposed within the probe member to cut a tissue specimen drawn into the interior of the device through the aperture by applying a vacuum to the inner lumen of the tissue cutting member. The driver has drive members for operating the elements of the probe component. The tissue penetrating distal tip preferably has a triple concave curvature shape with three curved cutting edges leading to a sharp distal point.

**9 Claims, 14 Drawing Sheets**

(73) Assignee: **SENORX, INC.**, Tempe, AZ (US)

(\*) Notice: Subject to any disclaimer, the term of this patent is extended or adjusted under 35 U.S.C. 154(b) by 2573 days.

(21) Appl. No.: **11/014,413**

(22) Filed: **Dec. 16, 2004**

(65) **Prior Publication Data**

US 2005/0159677 A1 Jul. 21, 2005

(51) **Int. Cl.**

**A61B 10/02** (2006.01)  
**A61B 17/32** (2006.01)

(Continued)

(52) **U.S. Cl.**

CPC ..... **A61B 10/0275** (2013.01); **A61B 10/0283** (2013.01); **A61B 17/32002** (2013.01); **A61B 17/32053** (2013.01); **A61B 17/3417** (2013.01); **A61B 2010/0208** (2013.01); **A61B 2010/0225** (2013.01); **A61B 2017/00207** (2013.01); **A61B 2017/00473** (2013.01); **A61B 2017/2911** (2013.01); **A61B 2017/2925** (2013.01); **A61B 2017/3405** (2013.01)

(58) **Field of Classification Search**

CPC ..... **A61B 10/0275**; **A61B 10/0283**; **A61B 17/32002**; **A61B 17/32053**; **A61B 17/3417**; **A61B 2010/0208**; **A61B 2010/0225**; **A61B 2010/00207**; **A61B 2010/00473**; **A61B 2010/2911**; **A61B 2010/2925**; **A61B 2010/3405**

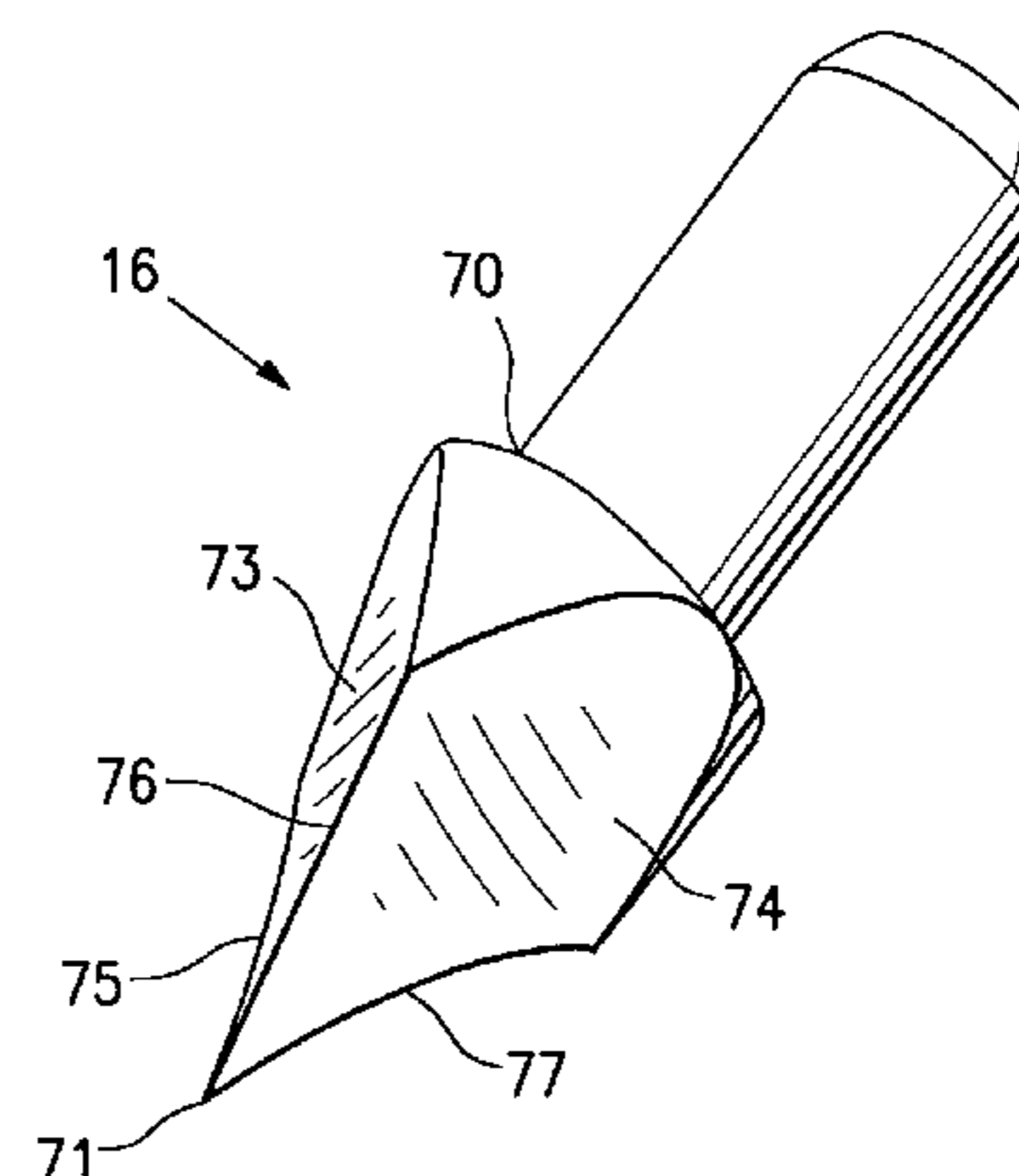
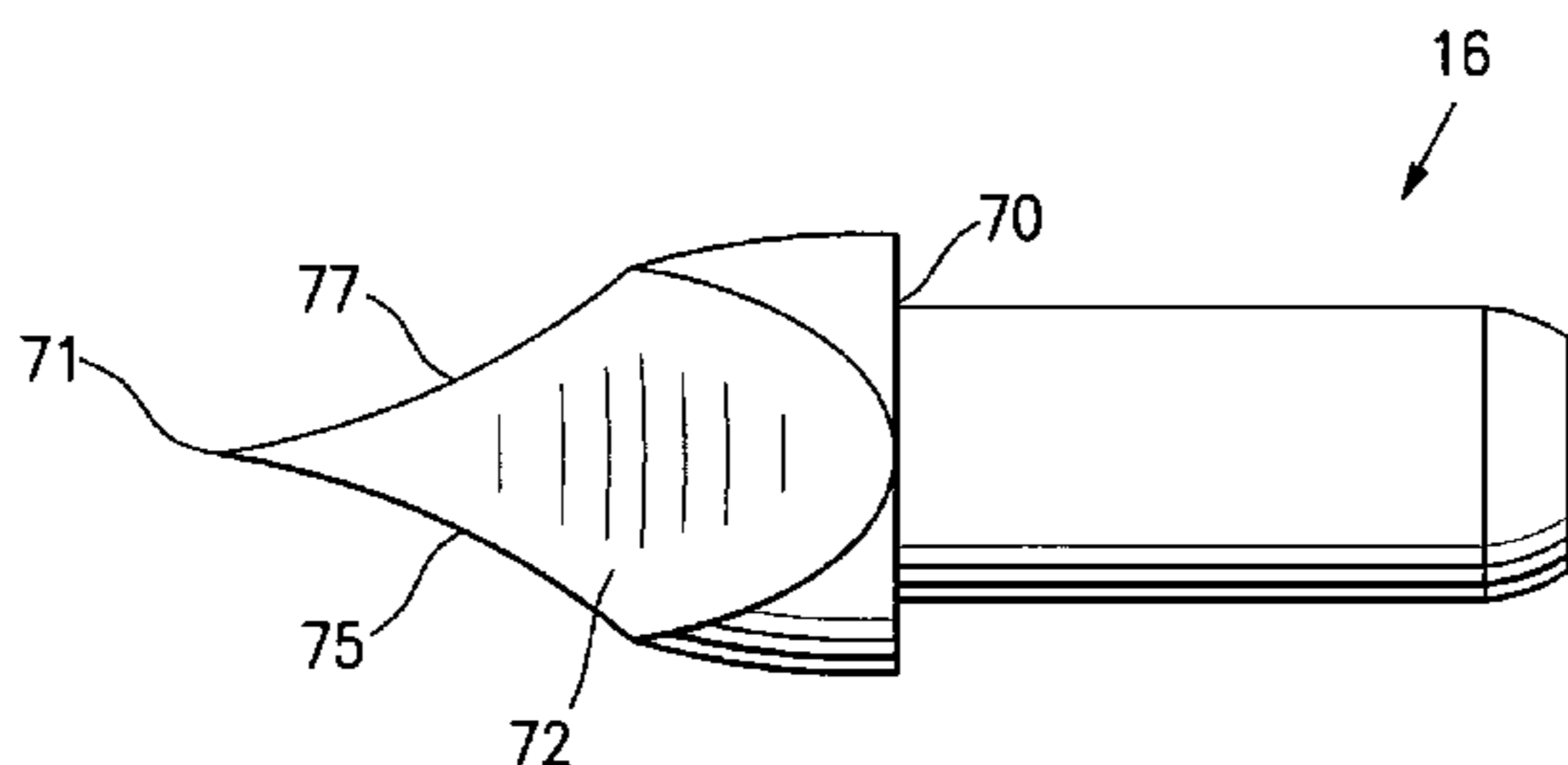

(51)	<b>Int. Cl.</b>			5,282,781 A	2/1994	Liprie
	<i>A61B 17/3205</i>	(2006.01)		5,312,400 A	5/1994	Bales et al.
	<i>A61B 17/34</i>	(2006.01)		5,318,564 A	6/1994	Eggers
	<i>A61B 17/00</i>	(2006.01)		5,320,613 A	6/1994	Houge et al.
	<i>A61B 17/29</i>	(2006.01)		5,323,768 A	6/1994	Saito et al.
				5,324,288 A	6/1994	Billings et al.
				5,334,381 A	8/1994	Unger
(56)	<b>References Cited</b>			5,335,671 A	8/1994	Clement
	<b>U.S. PATENT DOCUMENTS</b>			5,344,420 A	9/1994	Hilal et al.
				5,368,030 A	11/1994	Zinreich et al.
				5,374,188 A	12/1994	Frank et al.
				5,376,094 A	12/1994	Kline
	3,341,417 A	9/1967	Sinaiko	5,380,321 A	1/1995	Yoon
	3,788,320 A *	1/1974	Dye ..... 604/165.04	5,389,106 A	2/1995	Tower
	3,805,791 A	4/1974	Seuberth et al.	5,395,312 A	3/1995	Desai
	3,818,894 A	6/1974	Wichterle et al.	5,395,319 A	3/1995	Hirsch et al.
	3,823,212 A	7/1974	Chvapil	5,415,656 A	5/1995	Tihon et al.
	3,844,272 A	10/1974	Banko	5,417,687 A	5/1995	Nardella et al.
	3,847,153 A	11/1974	Weissman	5,417,697 A	5/1995	Wilk et al.
	3,910,279 A	10/1975	Okada et al.	5,422,730 A	6/1995	Barlow et al.
	3,945,375 A	3/1976	Banko et al.	5,423,809 A	6/1995	Klicek
	3,955,578 A	5/1976	Chamness et al.	5,423,814 A	6/1995	Zhu et al.
	4,007,732 A	2/1977	Kvavle et al.	5,431,649 A	7/1995	Mulier et al.
	4,172,449 A	10/1979	LeRoy et al.	5,433,204 A	7/1995	Olson et al.
	4,197,846 A	4/1980	Bucalo	5,437,665 A	8/1995	Munro
	4,202,338 A	5/1980	Bitrolf	5,441,498 A	8/1995	Perkins
	4,243,048 A	1/1981	Griffin	5,441,503 A	8/1995	Considine et al.
	4,276,885 A	7/1981	Tickner et al.	5,462,553 A	10/1995	Dolgin
	4,294,254 A	10/1981	Chamness	5,470,308 A	11/1995	Edwards et al.
	4,311,143 A	1/1982	Komiya	5,477,862 A	12/1995	Haga
	4,331,654 A	5/1982	Morris	5,484,436 A	1/1996	Eggers et al.
	4,362,160 A	12/1982	Hiltebrandt	5,487,385 A	1/1996	Avitall
	4,503,855 A	3/1985	Maslanka	5,488,958 A	2/1996	Topel et al.
	4,545,367 A	10/1985	Tucci	5,494,030 A	2/1996	Swartz et al.
	4,565,200 A	1/1986	Cosman	5,501,654 A	3/1996	Failla et al.
	4,576,162 A	3/1986	McCorkle	5,507,743 A	4/1996	Edwards et al.
	4,638,802 A	1/1987	Okada	5,526,822 A	6/1996	Burbank et al.
	4,643,187 A	2/1987	Okada	5,527,331 A	6/1996	Kresch et al.
	4,647,480 A	3/1987	Ahmed	5,538,010 A	7/1996	Darr et al.
	4,666,438 A *	5/1987	Raulerson ..... 604/272	5,542,948 A	8/1996	Weaver et al.
	4,682,606 A	7/1987	DeCaprio	5,549,560 A	8/1996	Van de Wijdeven
	4,693,237 A	9/1987	Hoffman et al.	5,578,030 A	11/1996	Levin
	4,718,419 A	1/1988	Okada	5,595,185 A	1/1997	Erlich et al.
	4,724,836 A	2/1988	Okada	5,597,378 A	1/1997	Jervis
	4,813,062 A	3/1989	Gilpatrick	5,599,347 A	2/1997	Hilal et al.
	4,847,049 A	7/1989	Yamamoto	5,607,389 A	3/1997	Edwards et al.
	4,853,470 A	8/1989	Strupczewski	5,611,803 A	3/1997	Heaven et al.
	4,863,470 A	9/1989	Carter	5,636,255 A	6/1997	Ellis
	4,909,250 A	3/1990	Smith	5,643,246 A	7/1997	Leeb et al.
	4,926,858 A	5/1990	Gifford, III et al.	5,643,282 A	7/1997	Kieturakis
	5,007,908 A	4/1991	Rydell	5,646,146 A	7/1997	Faarup et al.
	5,024,617 A	6/1991	Karpiel	5,649,547 A	7/1997	Ritchart et al.
	5,035,696 A	7/1991	Rydell	5,653,718 A	8/1997	Yoon
	5,041,124 A	8/1991	Kensley	5,665,085 A	9/1997	Nardella
	5,047,027 A	9/1991	Rydell	5,674,184 A	10/1997	Hassler, Jr.
	5,057,082 A	10/1991	Burchette, Jr.	5,676,663 A	10/1997	Kim
	5,059,204 A	10/1991	Lawson et al.	5,683,384 A	11/1997	Gough et al.
	5,064,424 A	11/1991	Bitrolf	5,687,739 A	11/1997	McPherson et al.
	5,066,295 A	11/1991	Kozak	5,688,490 A	11/1997	Tournier et al.
	5,078,716 A	1/1992	Doll	5,715,825 A	2/1998	Crowley
	5,080,660 A	1/1992	Buelna	5,720,763 A	2/1998	Tovey
	5,085,659 A	2/1992	Rydell	5,732,660 A	3/1998	David et al.
	RE33,925 E	5/1992	Bales et al.	5,741,225 A	4/1998	Lax et al.
	5,133,359 A	7/1992	Kedem	5,769,086 A	6/1998	Ritchart et al.
	5,133,360 A	7/1992	Spears	5,775,333 A	7/1998	Burbank et al.
	RE34,056 E	9/1992	Lindgren et al.	5,782,764 A	7/1998	Werne
	5,147,307 A	9/1992	Gluck	5,782,775 A	7/1998	Milliman et al.
	5,158,561 A	10/1992	Rydell et al.	5,794,626 A	8/1998	Kieturakis
	5,163,938 A	11/1992	Kambara et al.	5,797,907 A	8/1998	Clement
	5,195,533 A	3/1993	Chin et al.	5,800,378 A	9/1998	Edwards et al.
	5,196,007 A	3/1993	Ellman et al.	5,810,806 A	9/1998	Ritchart et al.
	5,197,846 A	3/1993	Uno et al.	5,814,044 A	9/1998	Hooven
	5,201,732 A	4/1993	Parins et al.	5,846,513 A	12/1998	Carrol et al.
	5,201,741 A	4/1993	Dulebohn	5,848,978 A	12/1998	Cecchi
	5,207,686 A	5/1993	Dolign	5,853,366 A	12/1998	Dowlatsahi
	5,217,458 A	6/1993	Parins	5,857,981 A	1/1999	Bucalo et al.
	5,224,488 A	7/1993	Neuffer	5,857,982 A	1/1999	Milliman et al.
	5,236,410 A	8/1993	Granov et al.	5,876,340 A	3/1999	Tu et al.
	5,281,218 A	1/1994	Imran	5,882,316 A	3/1999	Chu et al.
	5,281,408 A	1/1994	Unger			

(56)

References Cited

U.S. PATENT DOCUMENTS

5,902,272	A	5/1999	Eggers et al.	
5,913,857	A	6/1999	Ritchart et al.	
5,921,915	A	7/1999	Aznoian et al.	
5,925,044	A	7/1999	Hofmann et al.	
5,928,164	A	7/1999	Burbank et al.	
5,947,964	A	9/1999	Eggers et al.	
5,954,670	A	9/1999	Baker	
5,964,716	A	10/1999	Gregoire et al.	
5,972,002	A	10/1999	Bark et al.	
5,980,469	A	11/1999	Burbank et al.	
5,984,919	A	11/1999	Hilal et al.	
5,997,560	A	12/1999	Miller	
6,004,269	A	12/1999	Crowley et al.	
6,036,681	A	3/2000	Hooven	
6,050,955	A	4/2000	Bryan et al.	
6,056,700	A	5/2000	Burney et al.	
6,063,082	A	5/2000	DeVore et al.	
6,077,179	A	6/2000	Liechty, II	
6,120,462	A	9/2000	Hibner et al.	
6,142,955	A	11/2000	Farascioni et al.	
6,161,034	A	12/2000	Burbank et al.	
6,220,248	B1	4/2001	Voegelé et al.	
6,234,177	B1	5/2001	Barsch	
6,261,241	B1	7/2001	Burbank et al.	
6,277,083	B1	8/2001	Eggers et al.	
6,280,399	B1	8/2001	Rossin et al.	
6,312,429	B1	11/2001	Lubock et al.	
6,331,166	B1	12/2001	Burbank et al.	
6,344,026	B1	2/2002	Burbank et al.	
6,350,244	B1	2/2002	Fisher	
6,387,056	B1	5/2002	Kieturakis	
6,419,490	B1 *	7/2002	Kitchings Weathers, Jr.	433/165
6,454,727	B1	9/2002	Burbank et al.	
6,478,806	B2 *	11/2002	McFarlane	606/185
6,494,881	B1	12/2002	Bales et al.	
6,514,215	B1	2/2003	Ouchi	
6,514,248	B1	2/2003	Eggers et al.	
6,517,545	B1	2/2003	Mazur	
6,540,695	B1	4/2003	Burbank et al.	
6,638,234	B2	10/2003	Burbank et al.	
6,659,981	B2	12/2003	Stewart et al.	
6,679,851	B2	1/2004	Burbank et al.	
6,689,145	B2	2/2004	Lee et al.	
6,712,775	B2	3/2004	Burbank et al.	
6,758,824	B1	7/2004	Miller et al.	
7,070,010	B2	7/2006	Papousek	
7,189,206	B2	3/2007	Quick et al.	
7,201,722	B2 *	4/2007	Krueger	600/564
7,226,424	B2	6/2007	Ritchart et al.	
2001/0002250	A1	5/2001	Burbank et al.	
2003/0004407	A1	1/2003	Carroll et al.	
2004/0019299	A1	1/2004	Ritchart et al.	
2004/0134688	A1 *	7/2004	Papousek	175/415

FOREIGN PATENT DOCUMENTS

EP	0 146 699	9/1984
EP	0 255 123	2/1988
EP	0292936 A2	11/1988
EP	0 472 368 A2	8/1991
EP	0 509 670	10/1992
EP	0 601 709	6/1994
EP	0667126 A1	8/1995
EP	0 769 281	4/1997
EP	0858774 A2	8/1998
EP	WO 0 858 774 A2	8/1998
EP	0 919 190	6/1999
EP	0919192 A2	6/1999
EP	0 966 925	12/1999
EP	0 970 658	1/2000
EP	0983749 A2	3/2000
GB	2311468 A	10/1997
JP	H11262490 A	9/1999
JP	2001-158016	6/2001

JP	2005530554 A	10/2005
WO	93/13718	7/1993
WO	9314712 A1	8/1993
WO	94/01536	7/1994
WO	94/01537	7/1994
WO	95/02370	1/1995
WO	95/02371	1/1995
WO	95/03843	2/1995
WO	97/29702	8/1997
WO	9806346 A1	2/1998
WO	98/08441	3/1998
WO	WO 98/43531	10/1998
WO	9930764 A1	6/1999
WO	WO 99 44506 A	9/1999
WO	WO 00/12009	3/2000
WO	WO 00 16697	3/2000
WO	WO 01/49184	7/2001
WO	WO 02/22023	3/2002
WO	02062231 A2	8/2002
WO	02062232 A1	8/2002
WO	WO 2004/052212	6/2004
WO	2004075719 A2	9/2004
WO	WO 2005/063126	7/2005
WO	WO 2006/049911	5/2006

OTHER PUBLICATIONS

Whitman et al., Coaxial Core Needle Biopsy Under Mammographic Guidance: Indications and Applications, *AJR*:171, Jul. 1998, pp. 67-70.

Written Opinion mailed Jul. 18, 2000, PCT Rule 66, for International Application PCT/US99/21416.

Interstitial hyperthermia of colorectal liver metastases with a US-guided Nd:YAG laser with a diffuser tip: a pilot clinical Study; Christian P. Nolsoe, MD et al., *Radiology*, 1993; 187:333-337.

Hepatic metastases: Interstitial laser photocoagulation with real-time US monitoring and dynamic CT evaluation of treatment; Zehir Amin, MRCP et al., *Radiology* 1993; 187:339-347.

Clinical Thermochemotherapy, A Controlled Trial in Advanced Cancer Patients; F. Kristian Storm, MD, et al.; *Cancer* 1984; 55: 863-868.

HDR Brachytherapy for Osteolytic Metastases in Previously Irradiated Sites; L.L. Doss FACP, et al.; Chapter 101; Memorial Regional Cancer Center, Modesto, CA.

Brachytherapy as Sole Method for Early Breast Cancer; R.R. Kuske MD, et al; chapter 80; Os/chsner Medical Institutions, New Orleans, LA.

K. Desinger et al., A New Application System for Simultaneous Laser and Ultrasonic Transmission in Endoscopic Surgery (LUST), surgical applications of Energy, Vo. 33249, p. 94, Apr. 1998.

K. Desinger et al., Interstitial Bipolar RF-thermotherapy (RFITT) Therapy planning by computer simulation and MRI-monitoring—A new concept for minimally invasive procedures.; *Surgical Applications of Energy*, vol. 3249, p. 147, Apr. 1998.

Communication from the International Preliminary Examining Authority, Written Opinion (PCT Rule 66) dated Jul. 6, 2000.

The Dangers of Monopolar Electrosurgery and the Advantages of Bipolar Electrosurgery; Everest Medical; Technical Reviews; www.pycco.com/emc/techrwvs.htm; May 26, 1998.

Laser vs Electrosurgery; www.netvs.com/elmed/lasvselec.com; May 19, 1998.

Phototherapy of Tumors; by S.G. Brown, M.D.; University College Hospital, London, U.K.; *World Journal of Surgery* 7, 700-709, 1983.

Liver Photocoagulation with diode laser (805 nm) vs Nd:YAG laser (1064 nm).; *SPIE vol. 1646 Laser-Tissue Interaction III (1992)* pp. 107-125.

MR Imaging of Laser-Tissue Interactions; Ferenc A. Jotesz, MD et al.; *Magnetic Resonance Imaging*; Nov. 29, 1994; pp. 249-253.

Nd:YAG Interstitial Laser Phototherapy Guided by Magnetic Resonance Imaging in an Ex Vivo Model: Dosimetry of Laser-MR-Tissue Interaction; Yoshimi Anzai, MD et al.; *Laryngoscope* 101: Jul. 1991; pp. 755-760.

Temperature Mapping with MR Imaging of Molecular Diffusion: Application to Hyperthermia; Denis Le Bihan, MD, PhD, et al.; *Therapeutic Radiology*; Jun. 1989; pp. 853-857.

(56)

**References Cited**

## OTHER PUBLICATIONS

Interstitial Laser Hyperthermia in Tumor Therapy; A. Masters and S.G. Brown; *Annales Chirurgiae et Gynaecologiae* 79: 244-251, 1990.

Interstitial laser photocoagulation as a treatment for breast cancer; S.A. Harries et al., *British Journal of Surgery* 1994, :81, 1617-1619.

Ultrasound-Guided Cryosurgery for Tumor Ablation; Mar. 22, 1995; Sheraton Boston Hotel & Towers, Boston, MA; Sponsored by: Deconess Hospital.

High Dose Rate Endovascular Irradiation: Tolerance of Normal Tissues; Kenneth E. Gehman, MD et al., ISSN 8756-1687; Jul. 1994.

Endovascular Irradiation-A New Method to Avoid Recurrent Stenosis After Stent Implantation in Peripheral Arteries: Technique and Preliminary Results; H.D. Bottcher, MD et al.; 34<sup>th</sup> Annual Astro Meeting, San Diego, CA, Nov. 1992; *Int. J. Radiation Oncology Biol. Phys.*, vol. 29, No. 1, pp. 183-186, 1994.

Textbook of Radiotherapy, Third Edition; Lee & Febiger, 1980, Philadelphia; by Gilbert H. Fletcher, MD.

Moss' Radiation Oncology, Rationale, Technique, Results; Edited by James D. Cos, MD, FACR; Seventh Edition; Mosby, 1994.

International Search Report for PCT/US2004/043021, mailed Apr. 27, 2005.

Written Opinion of the International Searching authority for PCT/US2005/027071 mailed Jul. 5, 2006.

Armstrong, J. S., et al., "Differential Marking of Excision Planes in Screened Breast Lesions by Organically Coloured Gelatins", *Journal of Clinical Pathology*, Jul. 1990, No. 43 (7) pp. 604-607, XP000971447 abstract; tables 1, 2.

Lorentzen, T., Md, et al., "The Loop Electrode: A New Device for US-Guided Interstitial Tissue Ablation Using Radio Frequency Electrosurgery—An Animal Study", *Blackwell Science Ltd.*, 1996 *Min Incas There & Allied Technol* 5: 511-516.

Burbank, F., M.D., "Sterotactic Brest Biopsy; Its History, Its Present, and Its Future", *The American Surgeon*, Feb. 1996, vol. 62, pp. 128-150.

Fucci, V., et al., "Large Bowel Transit Times Using Radiopaque Markers in Normal Cats", *J. of Am. Animal Hospital Association.*, Nov.-Dec. 1995 31 (6) 473-477.

Schindlbeck, N.E., et al., "Measurement of Colon Transit Time" *J. of Gastroenterology*. No. 28. 399-404, 1990.

Written Opinion of the International Searching Authority for PCT/US99/21416 dated Jul. 18, 2000.

International Search Report for PCT/US2004/043021 mailed Apr. 27, 2005.

International Search Report for PCT/US2004/043021 mailed Jul. 26, 2005.

Written Opinion of the International Searching Authority for PCT/US2004/043021 mailed Jul. 26, 2005.

International Search Report for PCT/US2005/027071 mailed Mar. 21, 2006.

International Search Report for PCT/US2005/027071 mailed Jul. 5, 2006.

Written Opinion of the International Searching Authority for PCT/US2005/027071 mailed Feb. 3, 2007.

Storm, et al., "Clinical Thermochemotherapy, A Controlled Trial in Advanced Cancer Patients", *Cancer*, Feb. 15, 1984, pp. 863-868, vol. 53.

Doss, et al., "HDR Brachytherapy for Osteolytic Metastases in Previously Irradiated Sites", *International Brachytherapy*, Chapter 101, Sep. 1992, pp. 412-415, Memorial Regional Cancer Center, Modesto, CA.

Kuske, et al. "Brachytherapy as Sole Method for Early Breast Cancer", *International Brachytherapy*, Chapter 80, pp. 347-348, Ochsner Medical Institutions, New Orleans, Louisiana.

Desinger, et al., "A New Application System for Simultaneous Laser and Ultrasonic Transmission in Endoscopic Surgery (LUST)", *Surgical Applications of Energy*, 94, vol. 3249 Apr. 2, 1998, San Jose, CA.

Desinger, et al., "Interstitial bipolar RF-thermotherapy (RFITT) Therapy planning by computer simulation and MRI-monitoring—A new concept for minimally invasive procedures—" *Surgical Applications of Energy*, 147, vol. 3249, Apr. 2, 1998, San Jose, CA.

"The Dangers of Monopolar Electrosurgery and the Advantages of Bipolar Electrosurgery", Everest Medical, Technical Reviews; [www.pycco.com/emc/techrws.html](http://www.pycco.com/emc/techrws.html), May 26, 1998, pp. 1-9.

Hausner, K, "Laser VS Electrosurgery", [www.netvs.com/elmed/lasvselec.htm](http://www.netvs.com/elmed/lasvselec.htm), May 19, 1998, pp. 1-4.

Bown, S. G. , "Phototherapy of Tumors", *World Journal of Surgery*, 1983, vol. 7, pp. 700-709, University College Hospital, London, United Kingdom.

Jacques, et al., "Liver photocoagulation with diode laser (805 nm) vs Nd:YAG laser (1064 nm)", *SPIE vol. 1646 Laser-Tissue Interaction III* 1992, pp. 107-125.

Jolesz, et al., "MR Imaging of Laser-Tissue Interactions", *Magnetic Resonance Imaging, Radiology*, Jul. 1988; pp. 249-253, vol. 168.

Anzai, et al., "Nd:YAG Interstitial Laser Phototherapy Guided by Magnetic Resonance Imaging in an Ex Vivo Model: Dosimetry of Laser-MR-Tissue Interaction", *Laryngoscope* 101: Jul. 1991, pp. 755-760.

Le Bihan, et al., "Temperature Mapping with MR Imaging of Molecular Diffusion; Application to Hyperthermia", *Therapeutic Radiology, Radiology*, Jun. 1988, pp. 853-857, vol. 171.

Masters, et al., "Interstitial Laser Hyperthermia in Tumour Therapy", *Annales Chirurgiae et Gynaecologiae* 79: 244-251, 1990.

Harries, et al., "Interstitial laser photocoagulation as a treatment for breast cancer", *British Journal of Surgery* 1994, 81, 1617-1619.

"Ultrasound-Guided Cryosurgery for Tumor Ablation", Mar. 22, 1995, Sheraton Boston Hotel & Towers, Boston, MA, Sponsored by: Deconess Hospital.

Gehman, et al., "High Dose Rate Endovascular Irradiation; Tolerance of Normal Tissues", *Endocurietherapy/Hyperthermia Oncology*, Jul. 1994, vol. 10, pp. 167-171, ISSN 8756-1687.

Sottcher, et al. "Endovascular Irradiation—A New Method to Avoid Recurrent Stenosis After Stent Implantation in Peripheral Arteries: Technique and Preliminary Results", 34<sup>th</sup> Annual ASTRO Meeting, San Diego, CA, Nov. 1992, *International Journal of Radiation Oncology Biol. Phys.*, vol. 29, No. 1, pp. 183-186, 1994.

Fletcher, G. H., "Textbook of Radiotherapy" Third Edition, Lea & Febiger, 1980, Philadelphia.

Cox, J. D., "Moss' Radiation Oncology: Rationale, Technique, Results" Seventh Edition, Mosby 1994.

\* cited by examiner

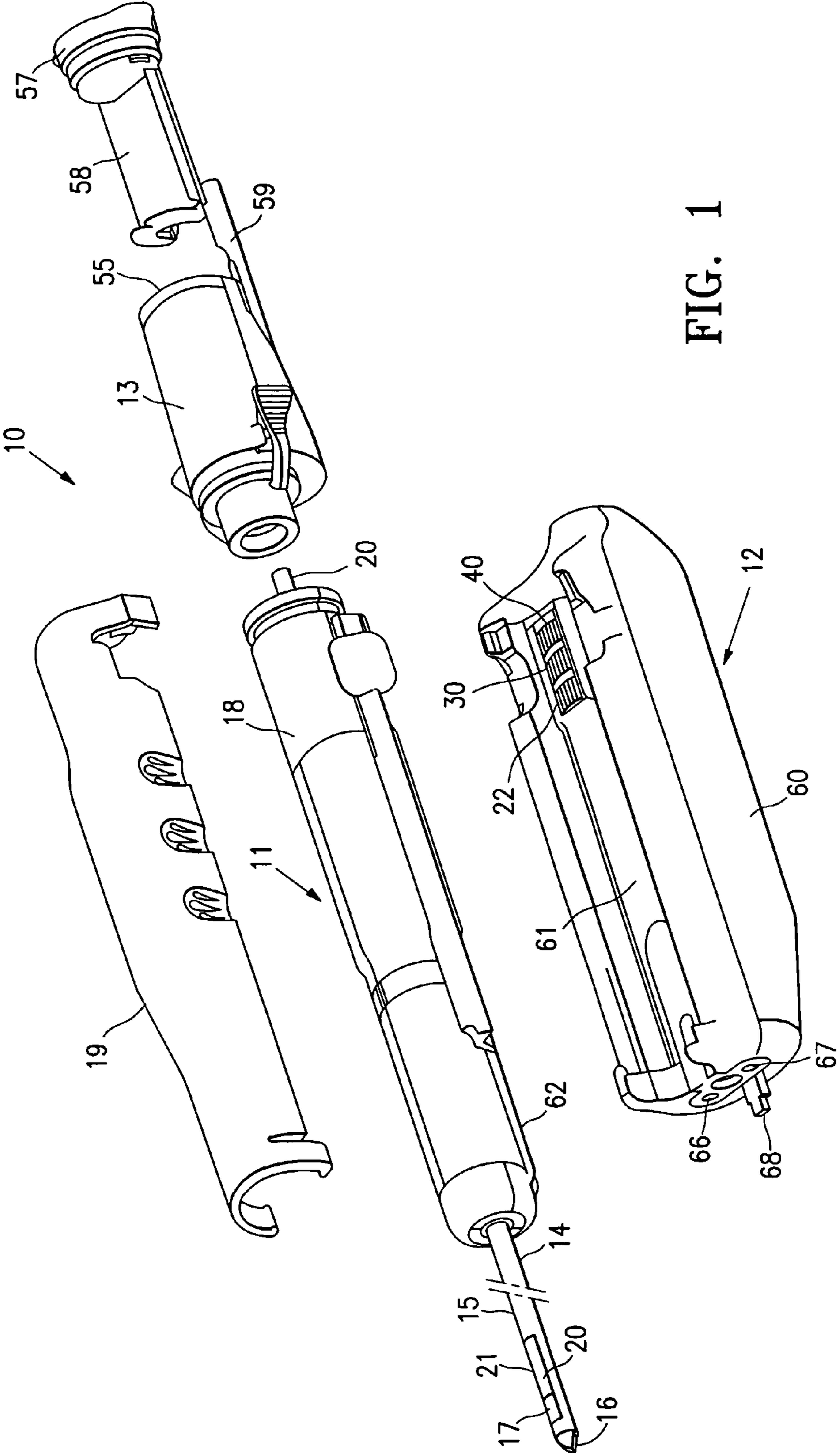

FIG. 1

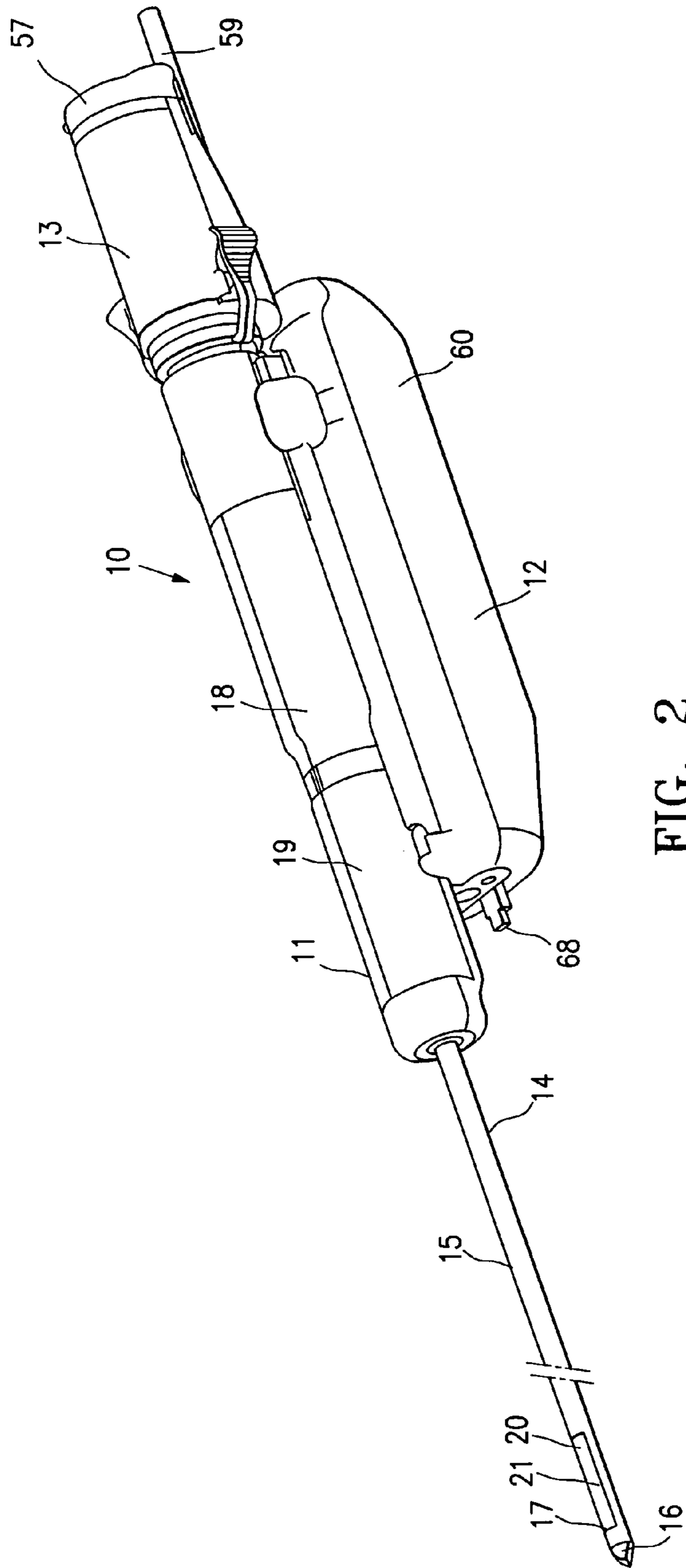
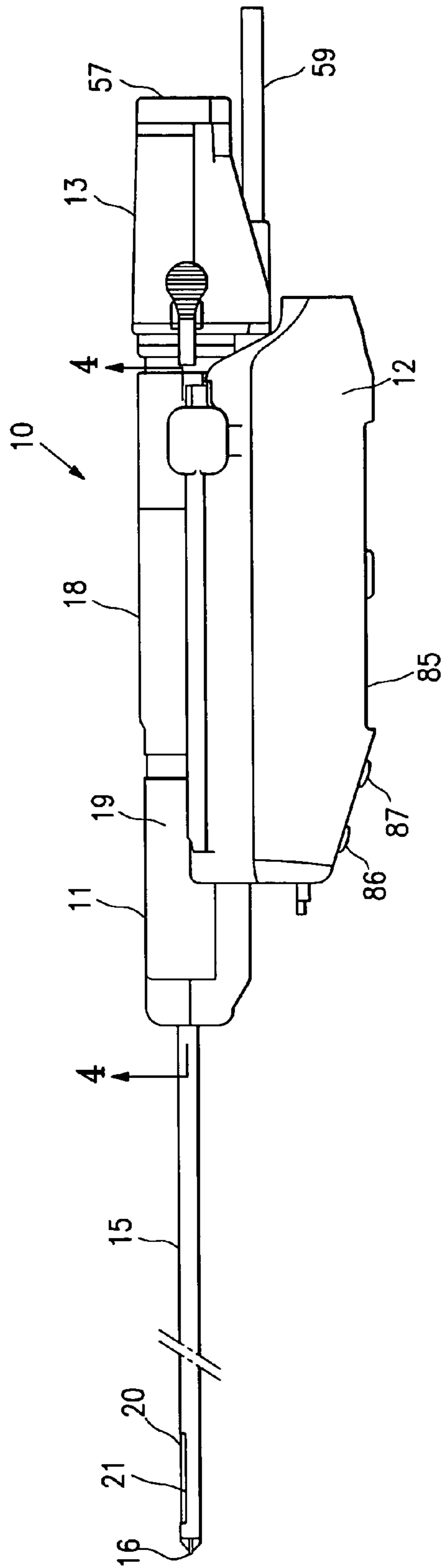

FIG. 2



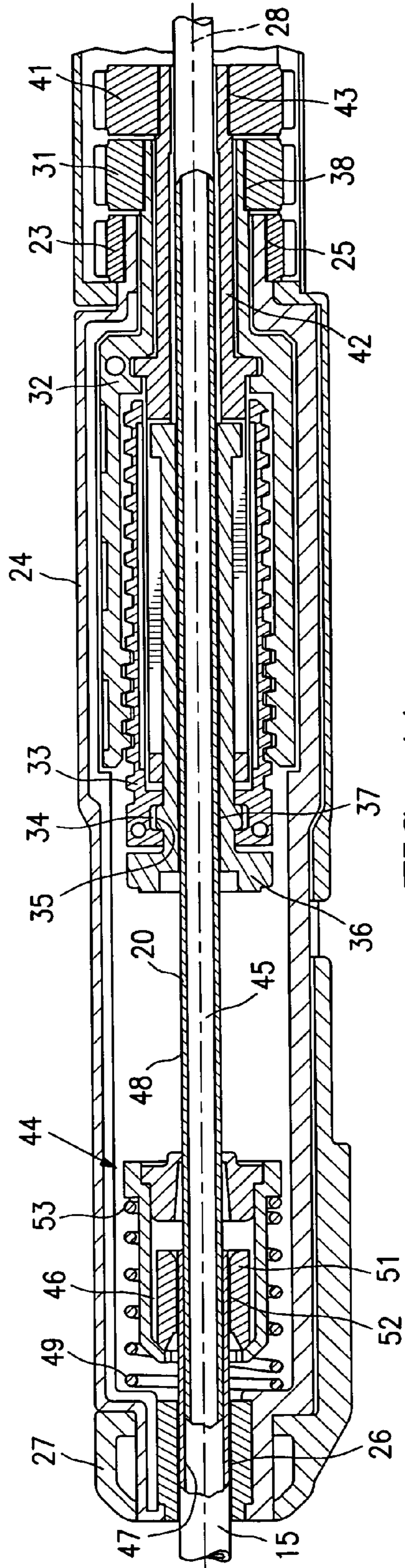

FIG. 4A

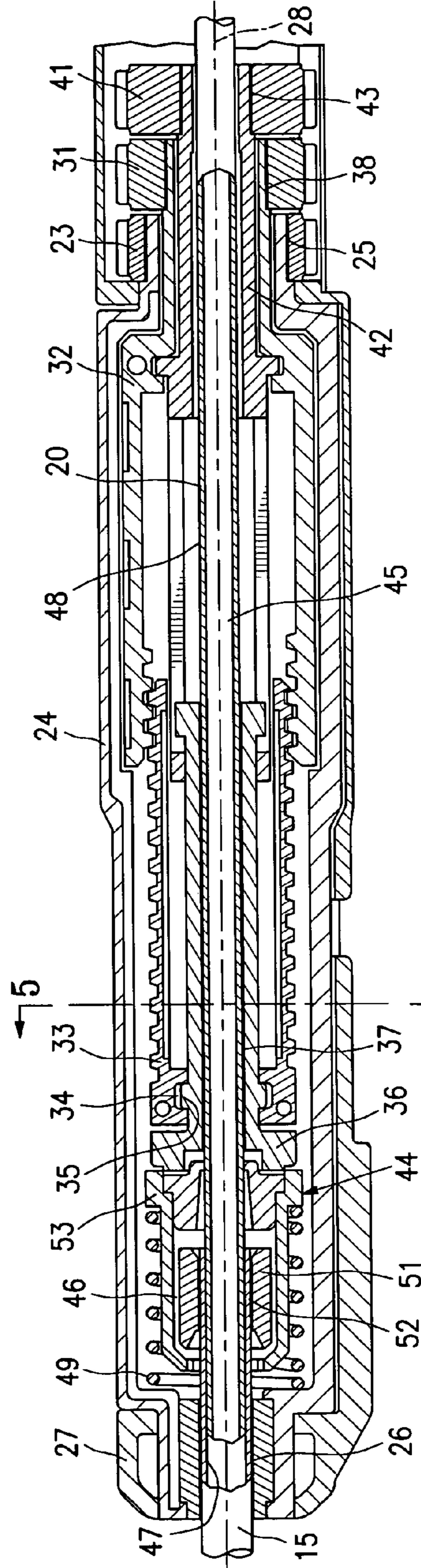

FIG. 4B



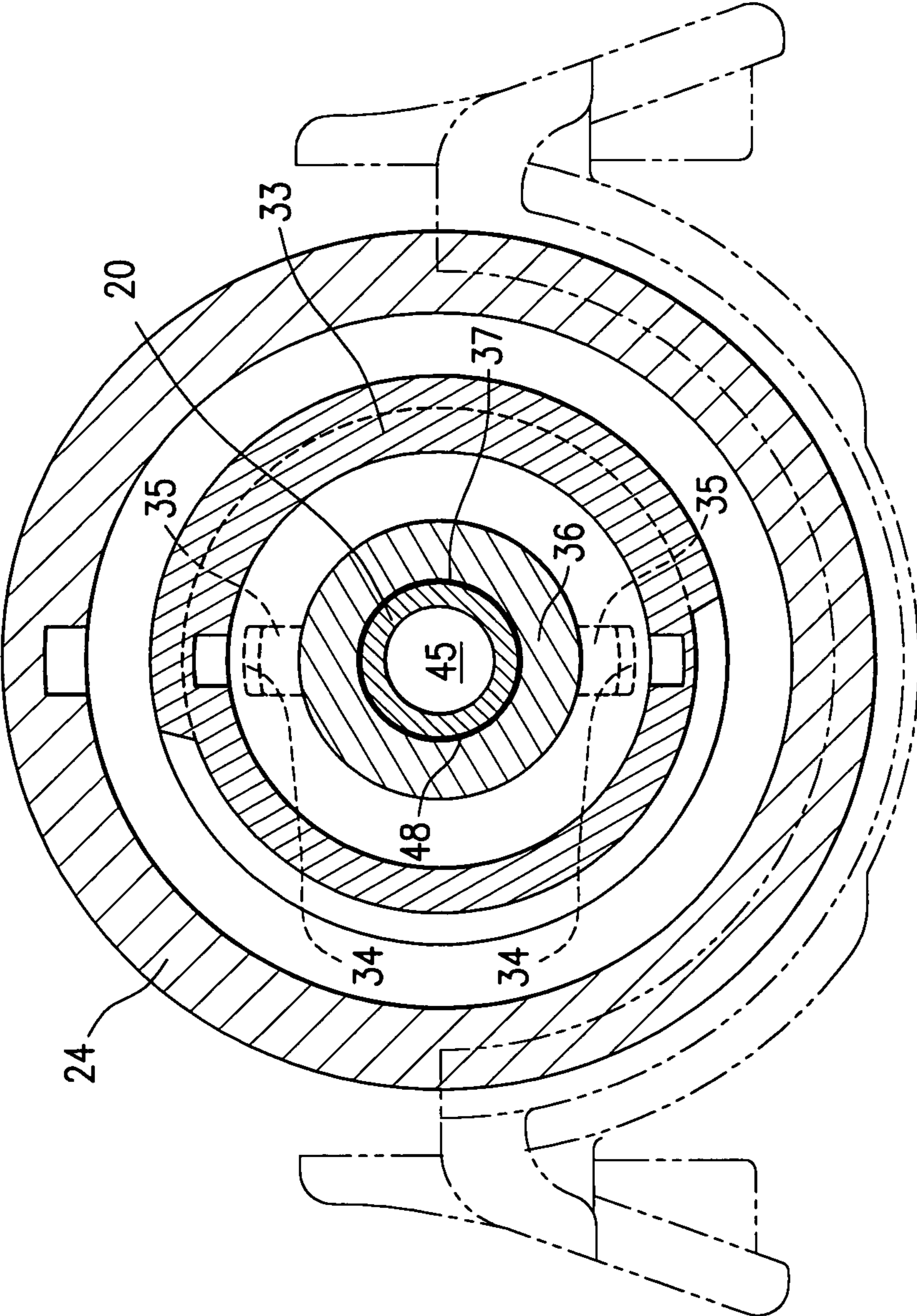

FIG. 5

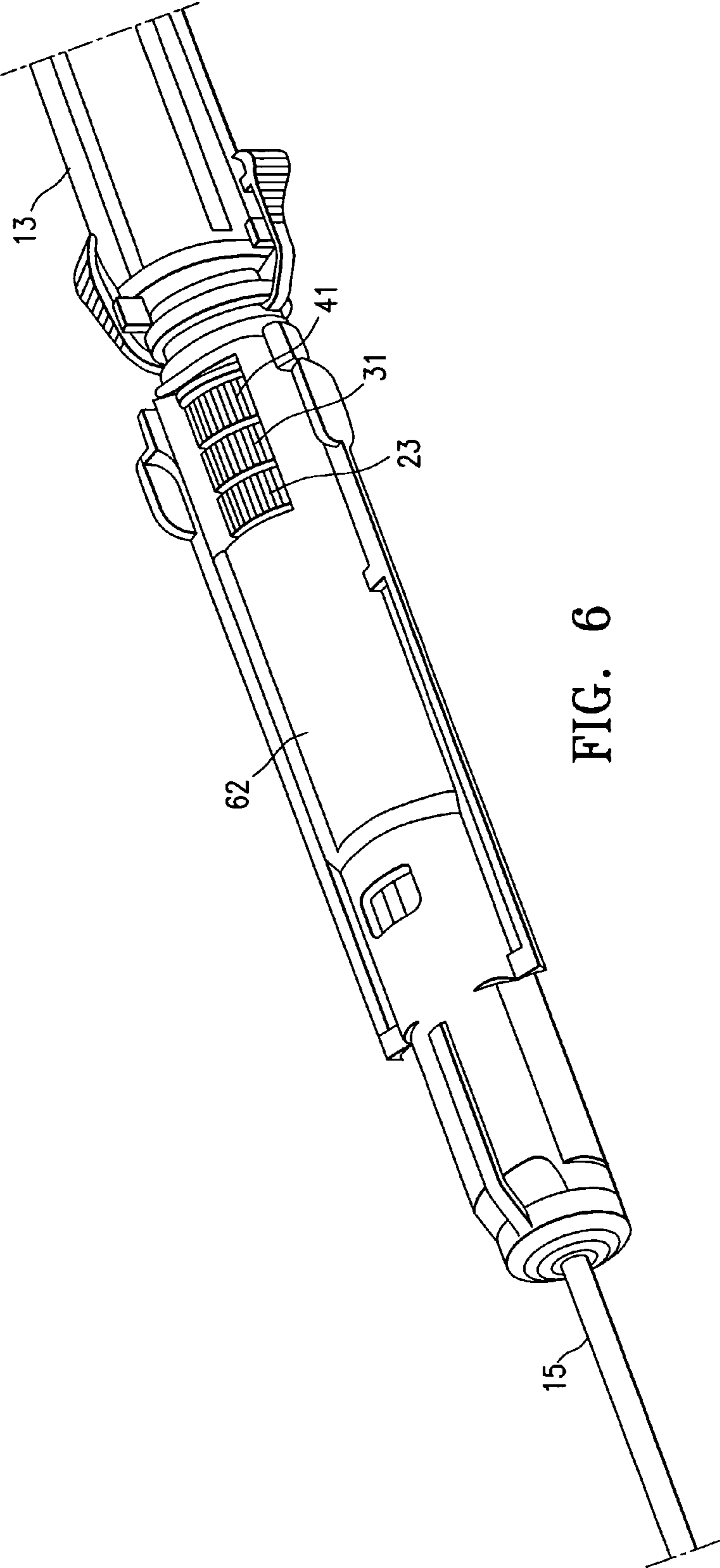

FIG. 6

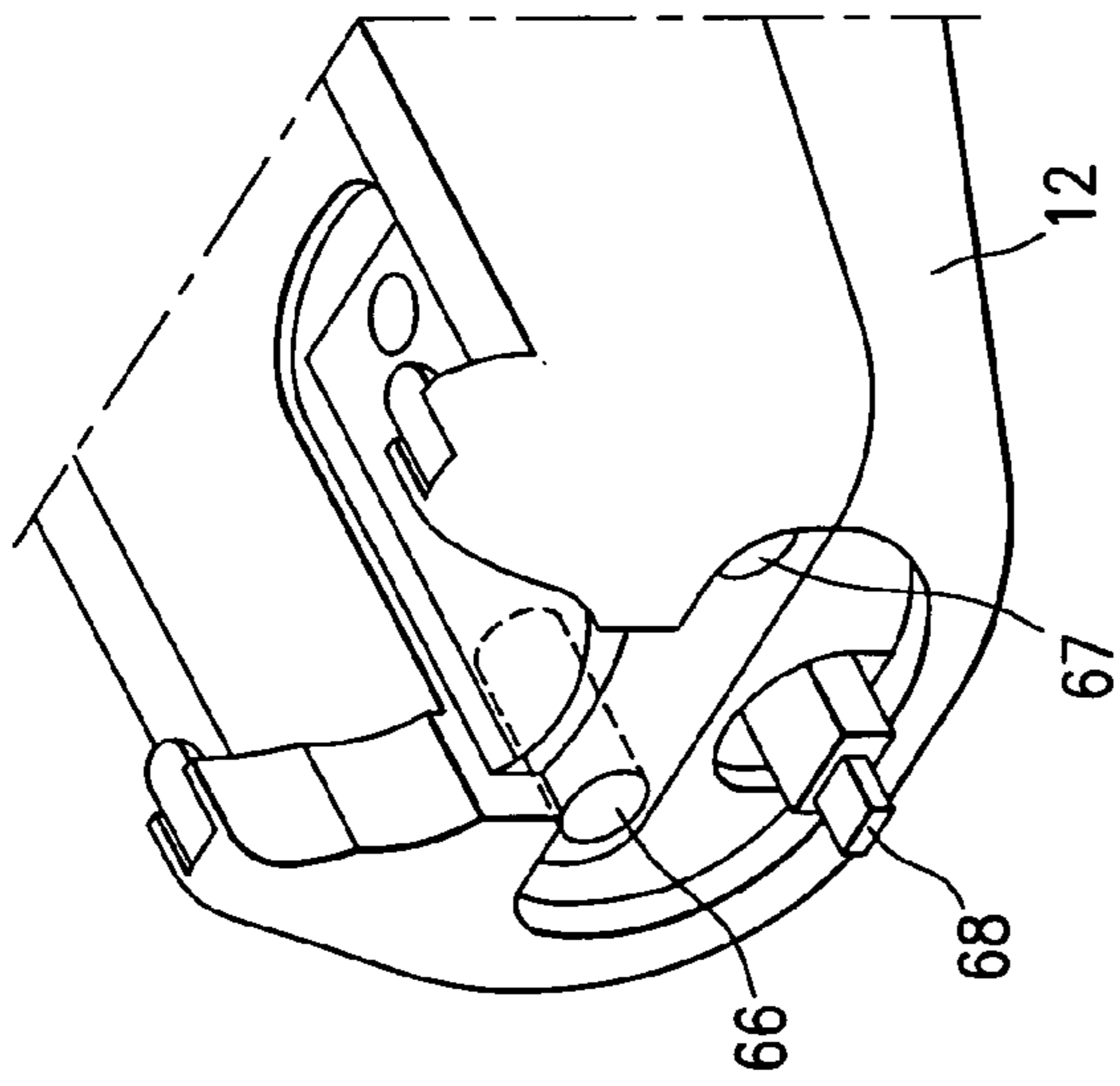

FIG. 7

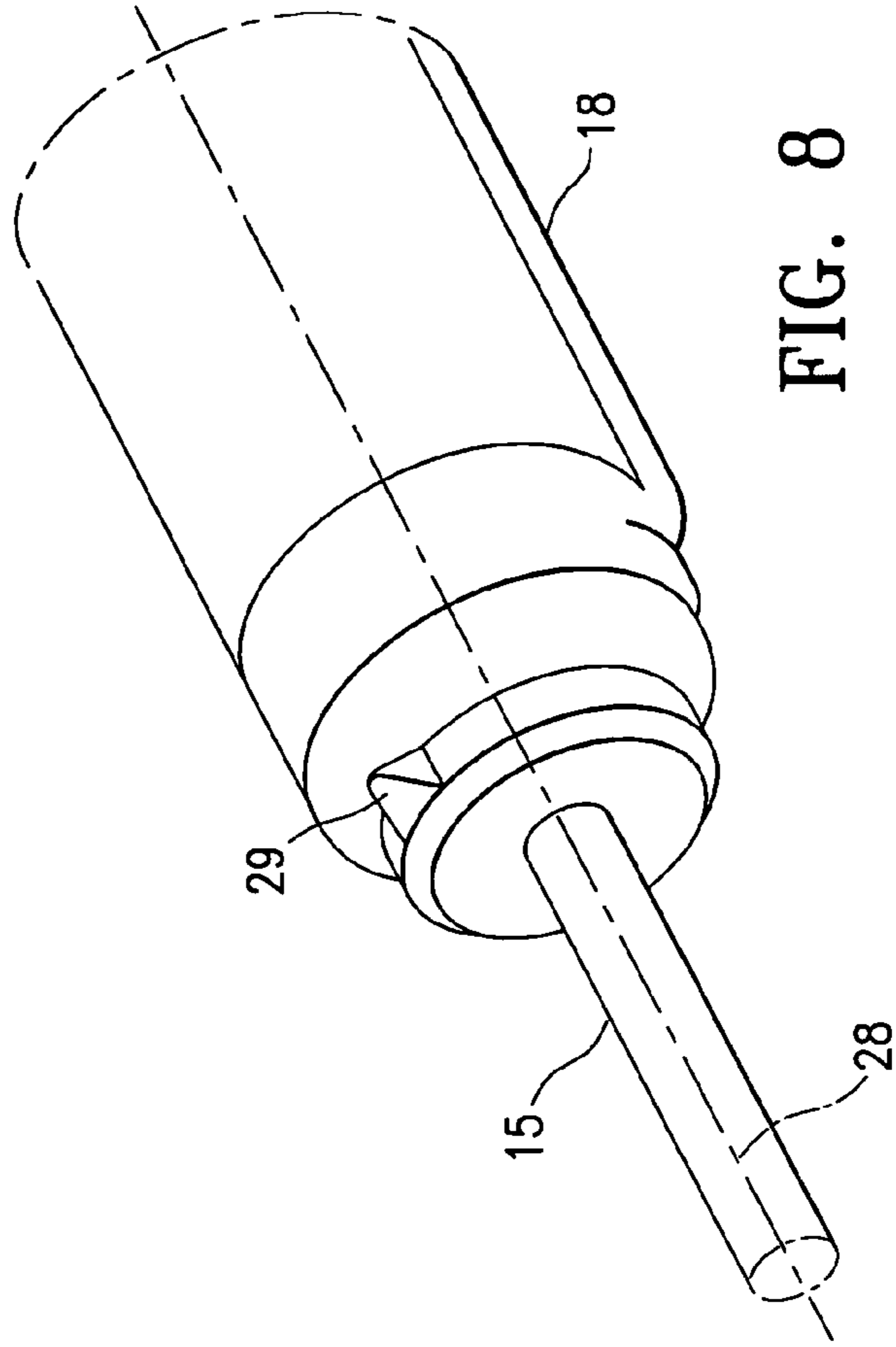

FIG. 8

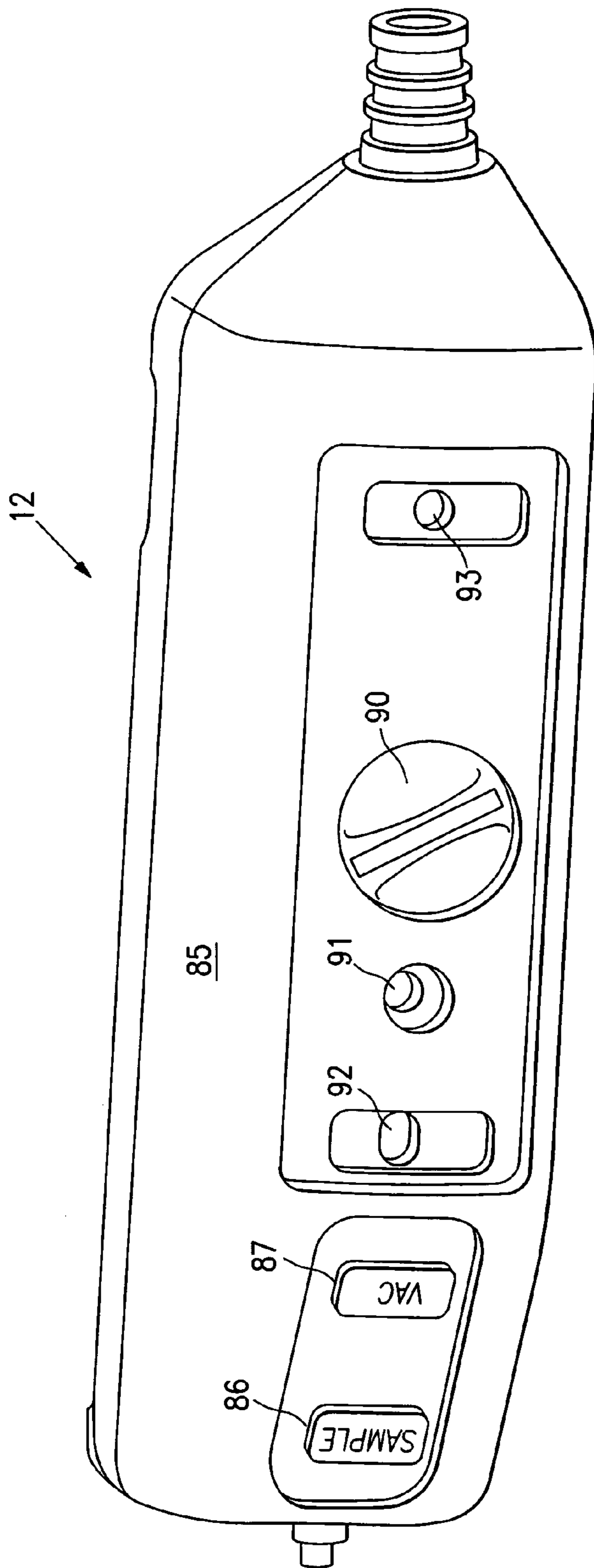

FIG. 9

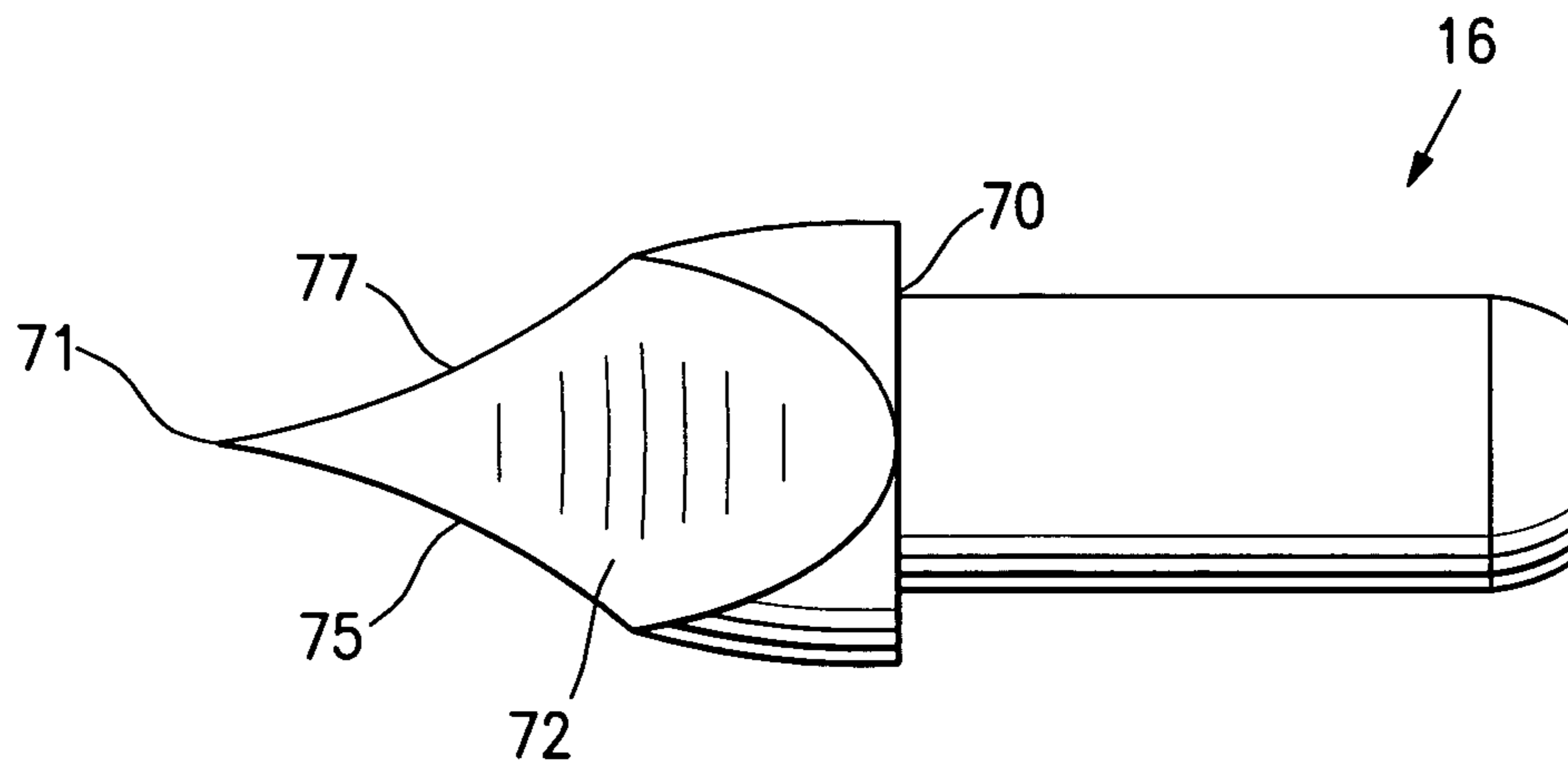

FIG. 10

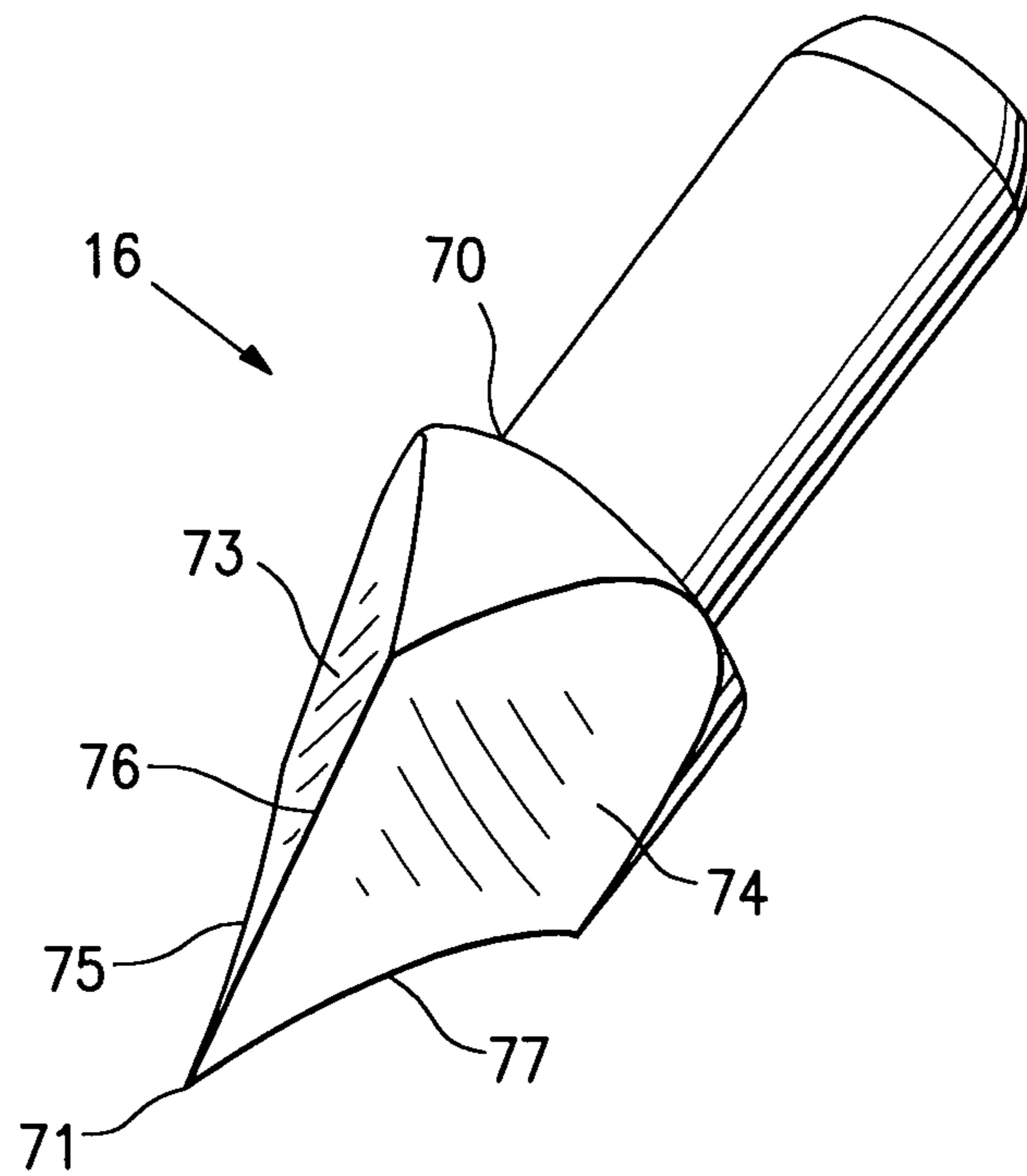

FIG. 11

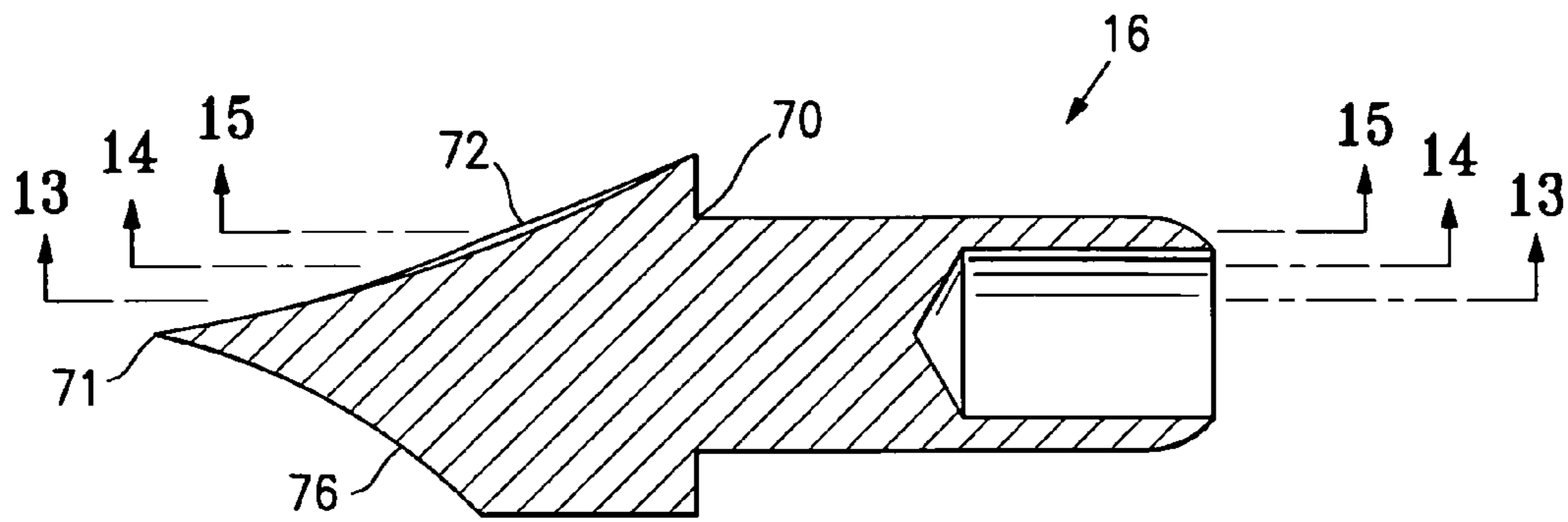

FIG. 12

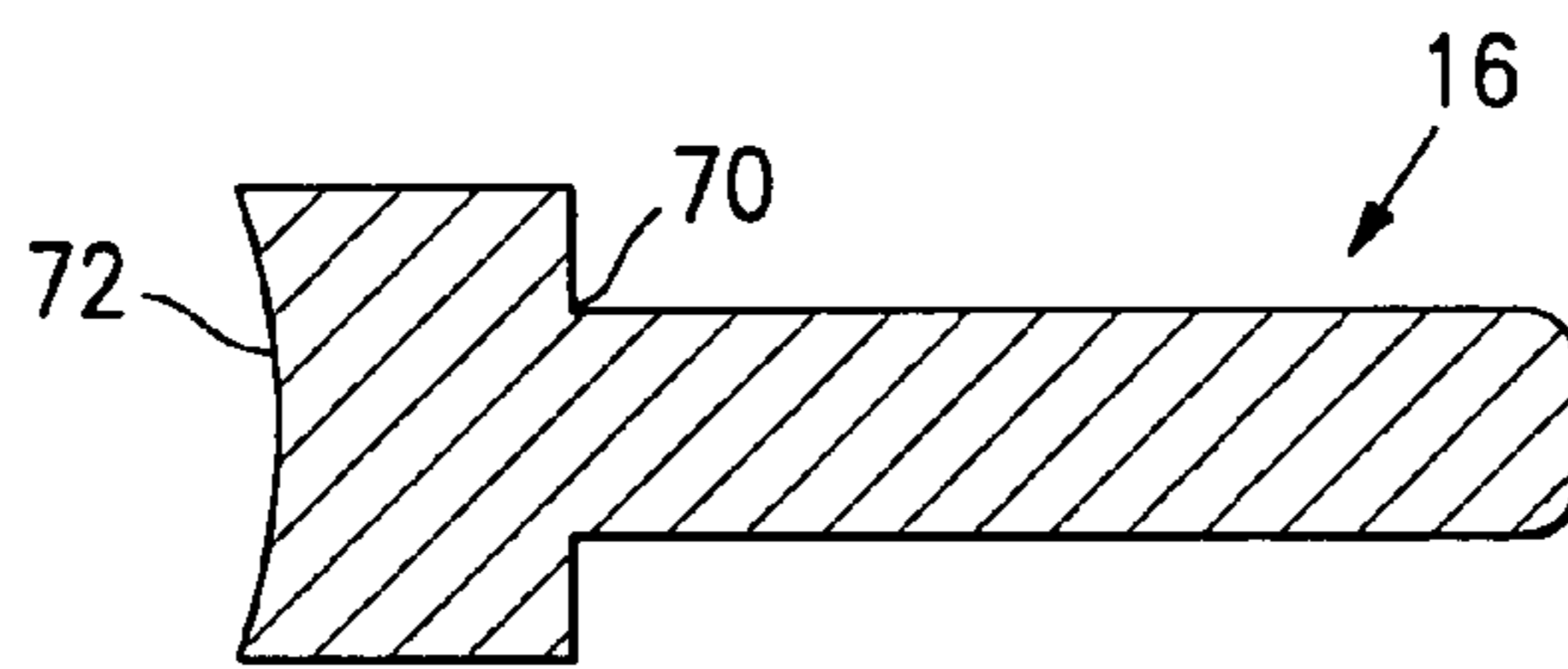

FIG. 13

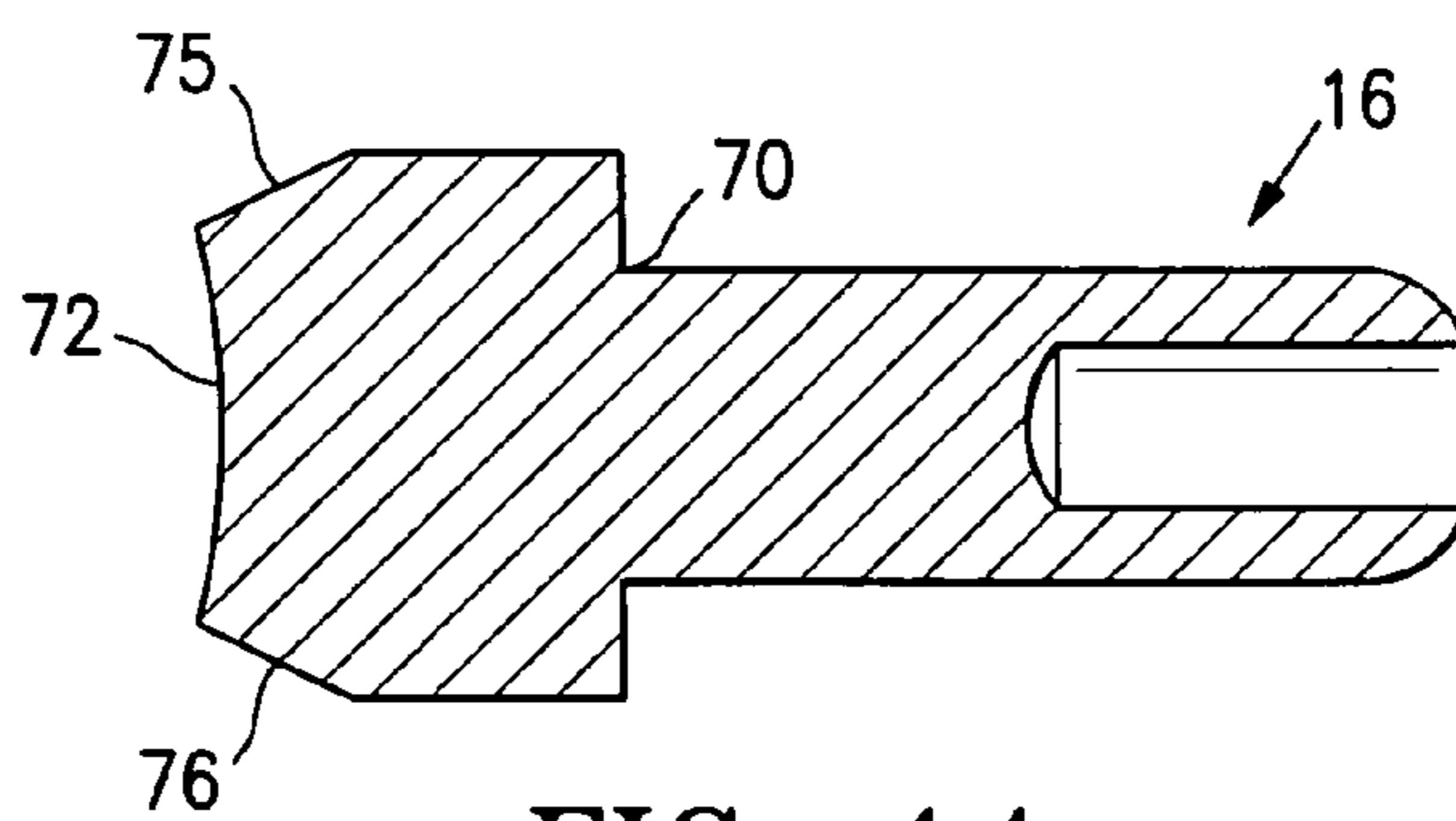

FIG. 14

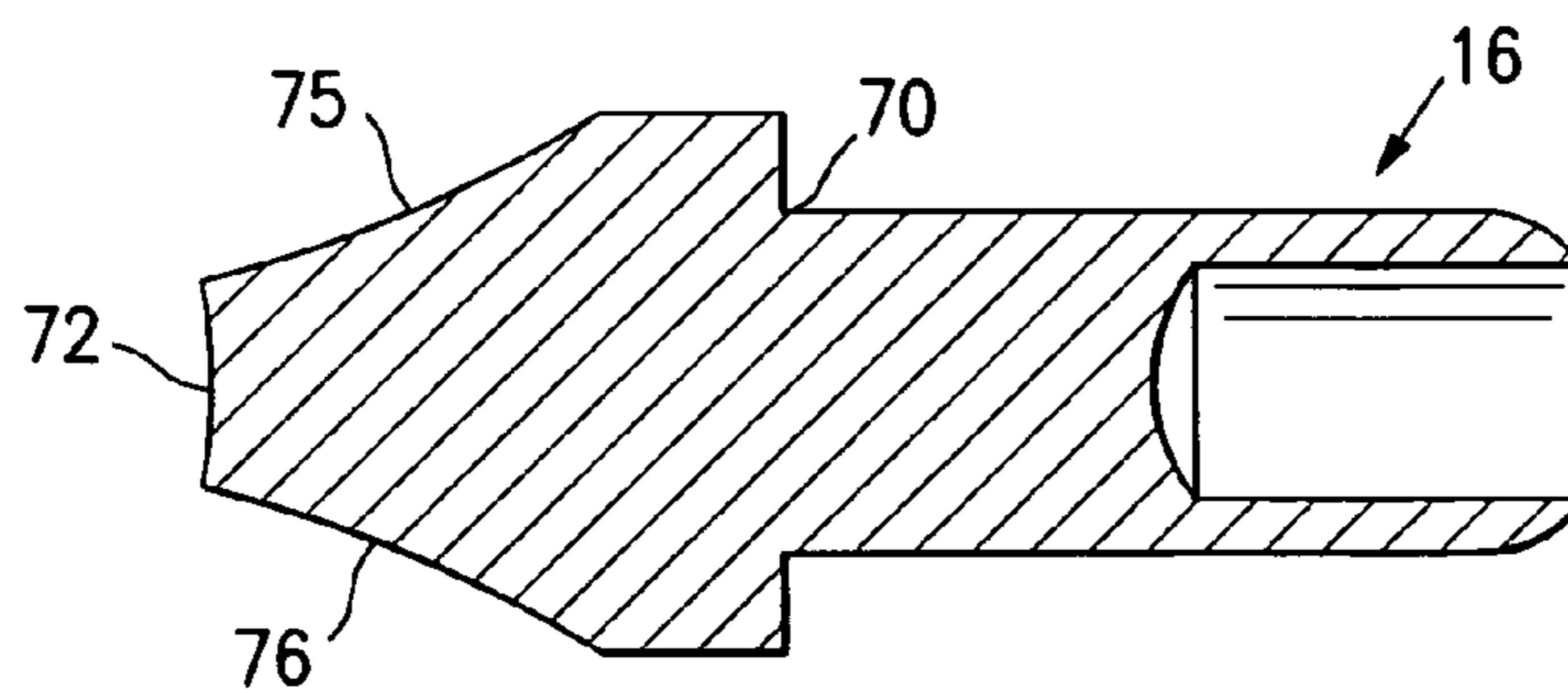

FIG. 15

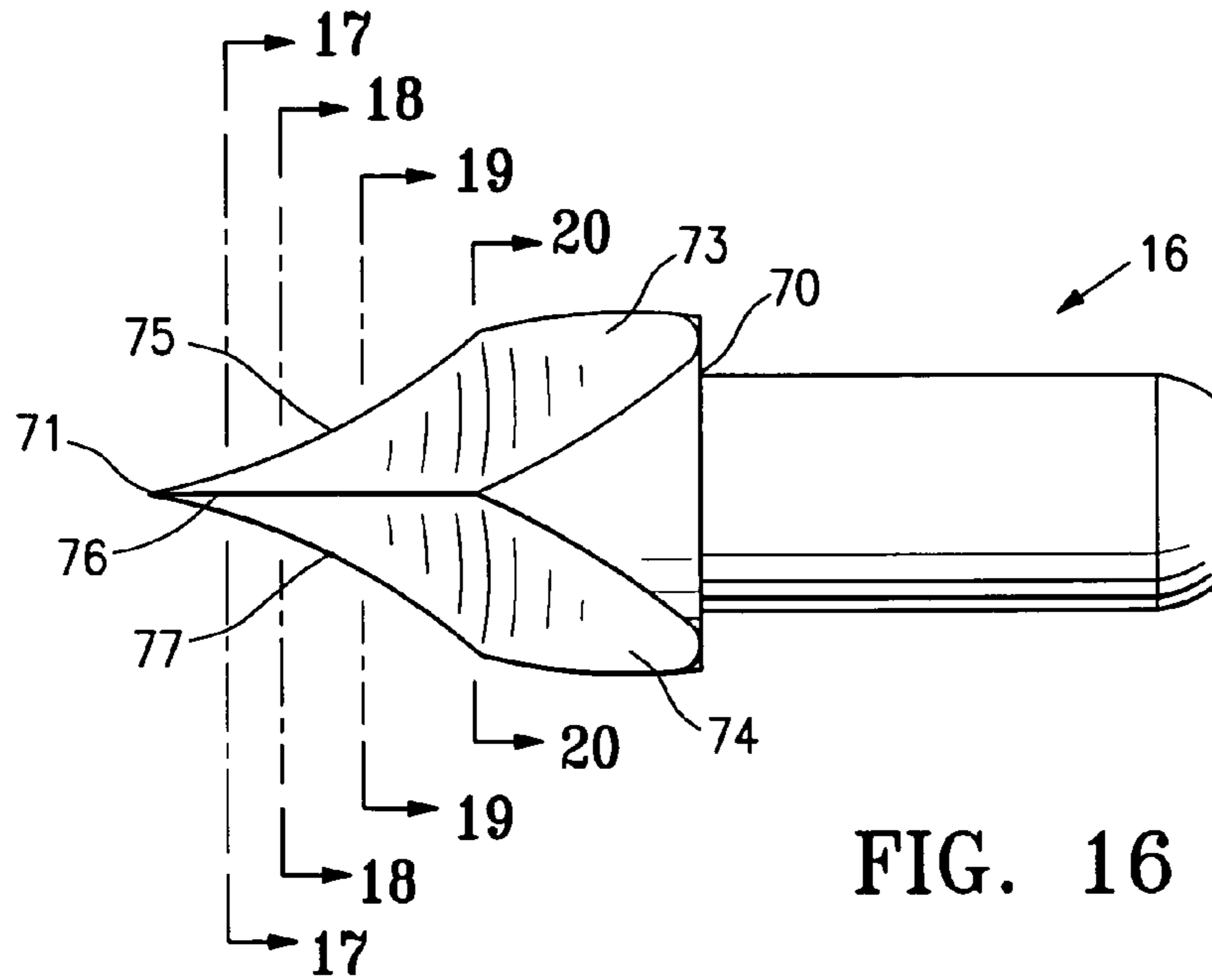

FIG. 16

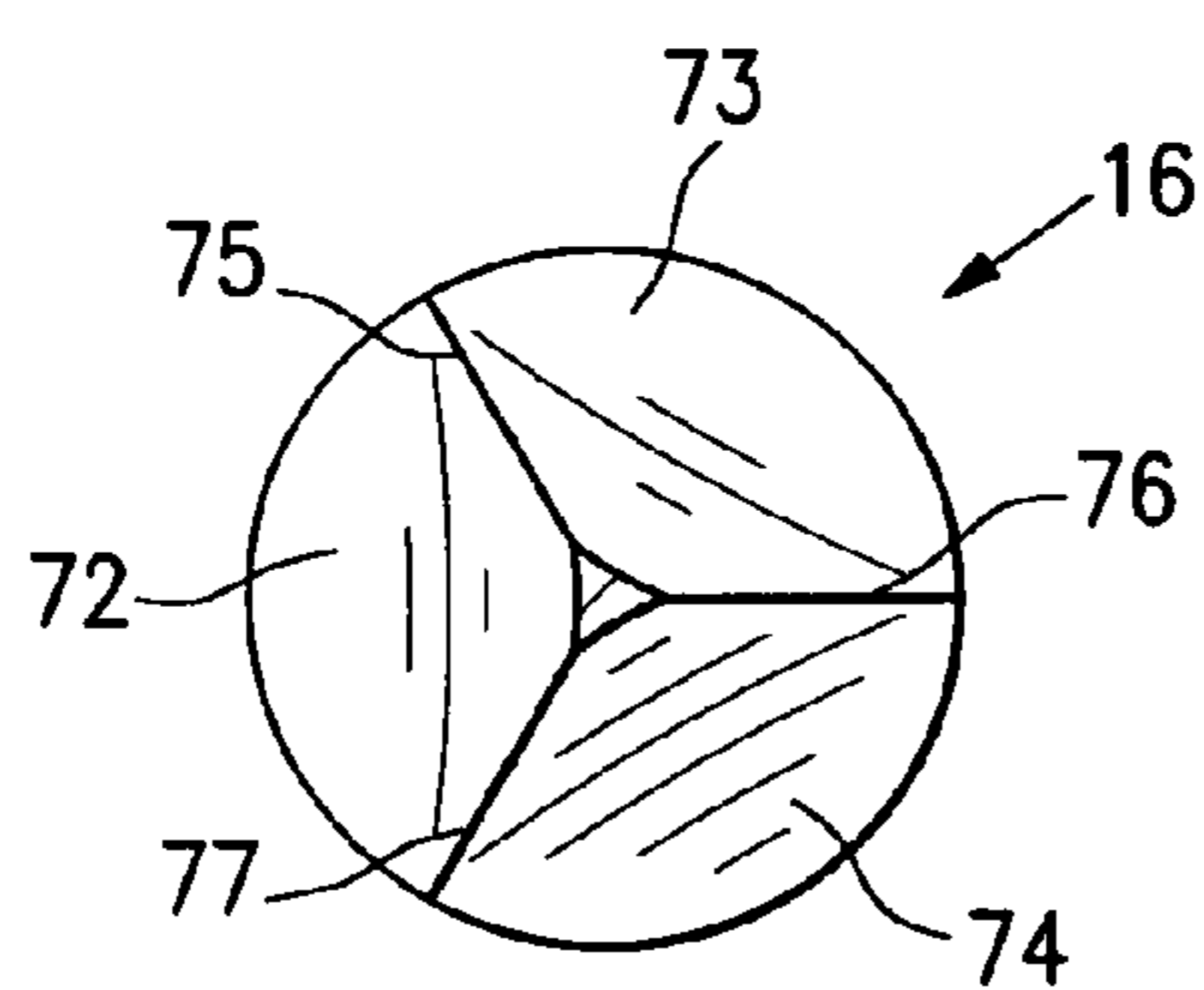

FIG. 17

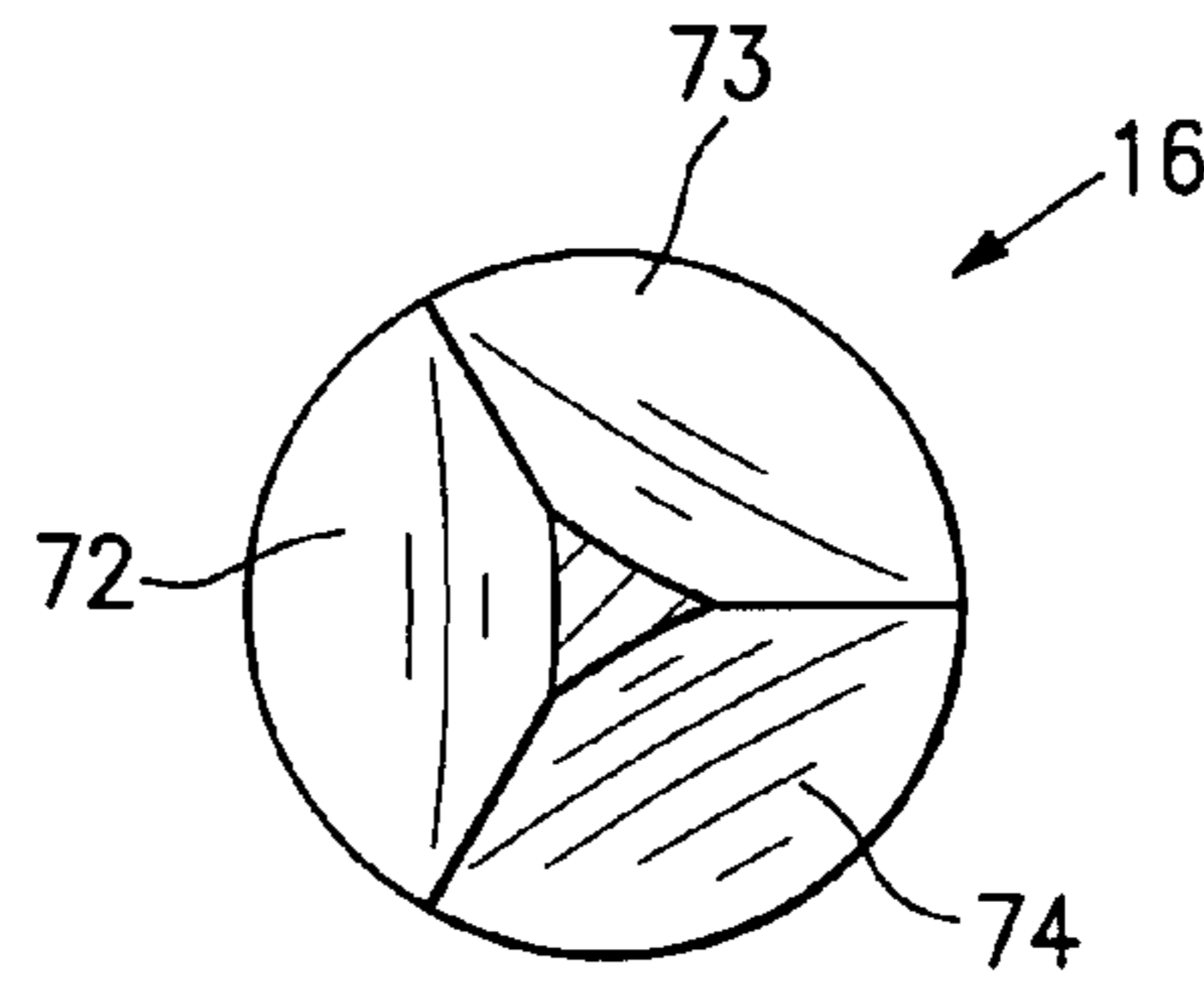

FIG. 18

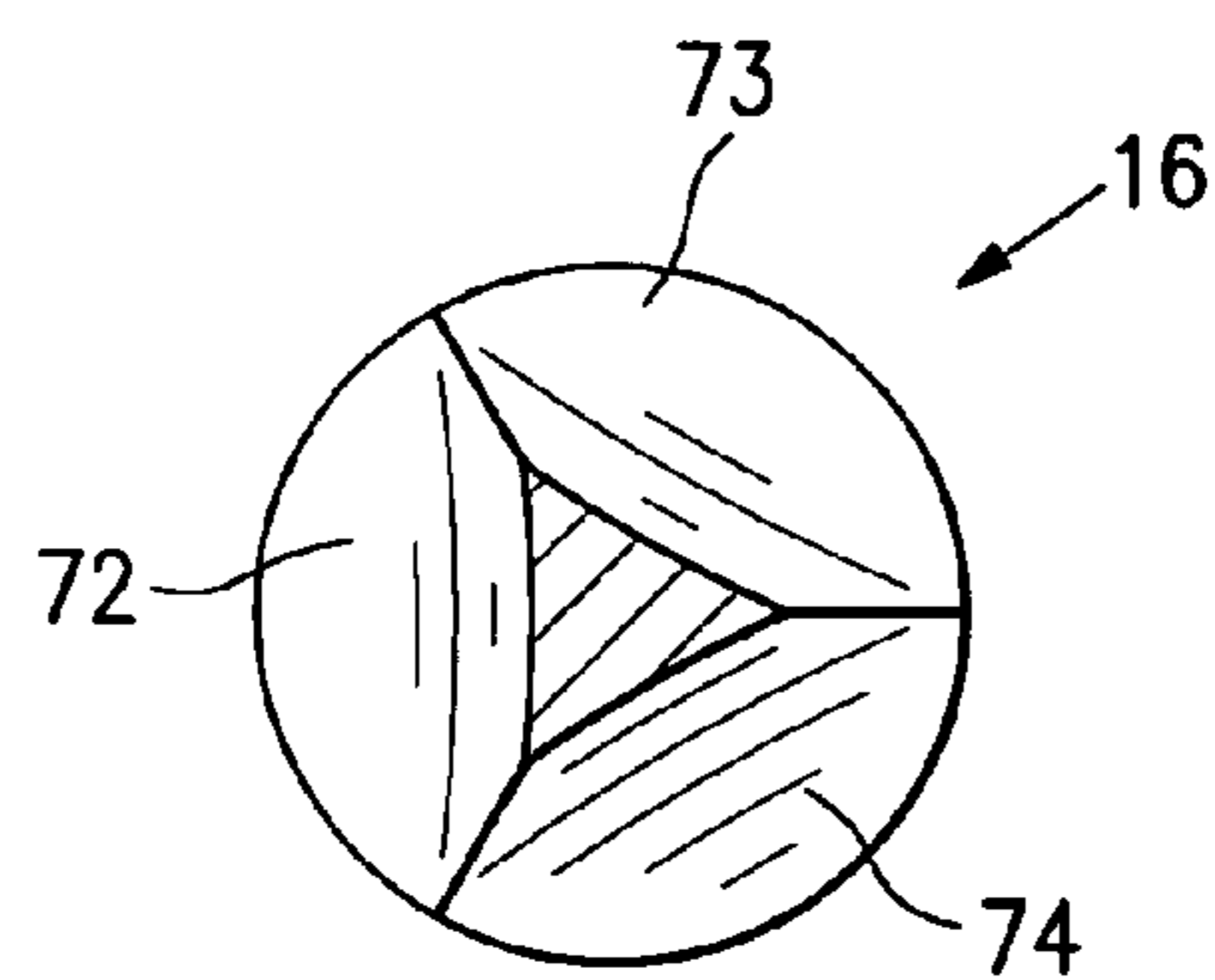

FIG. 19

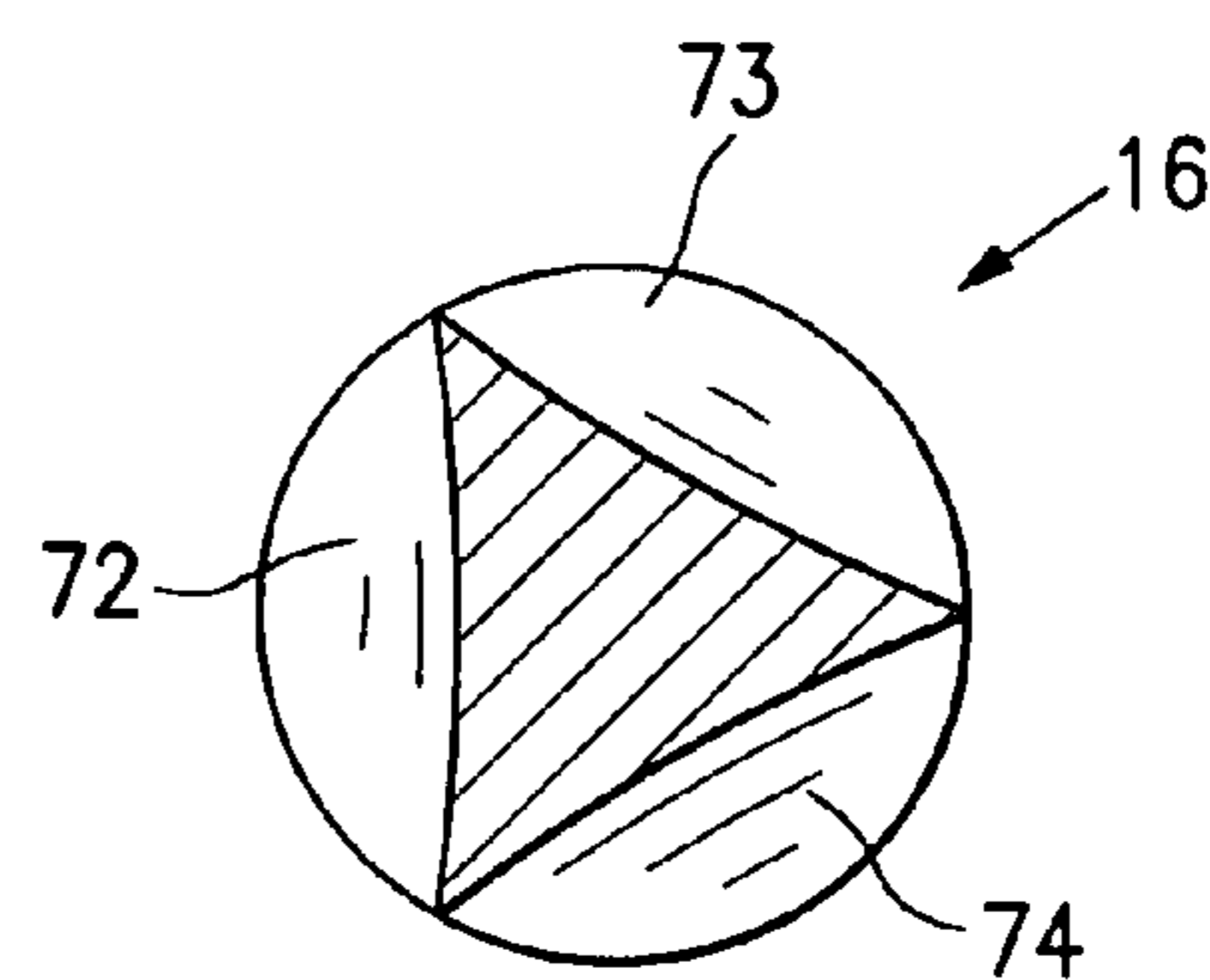

FIG. 20

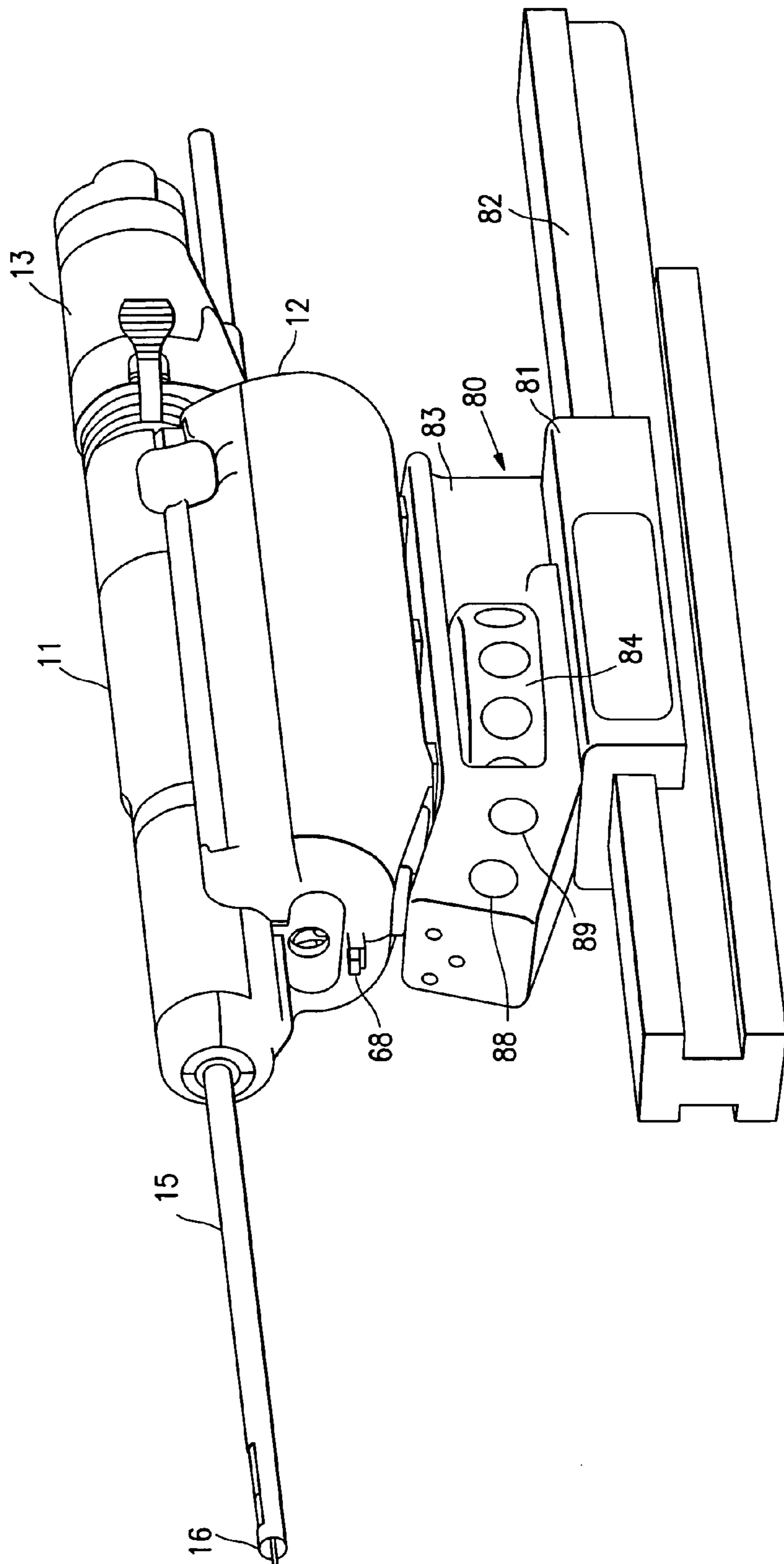

FIG. 21



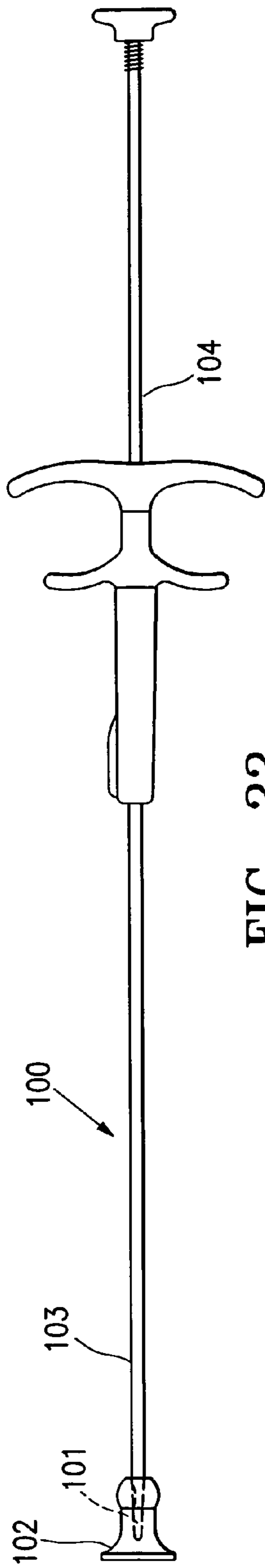

FIG. 22

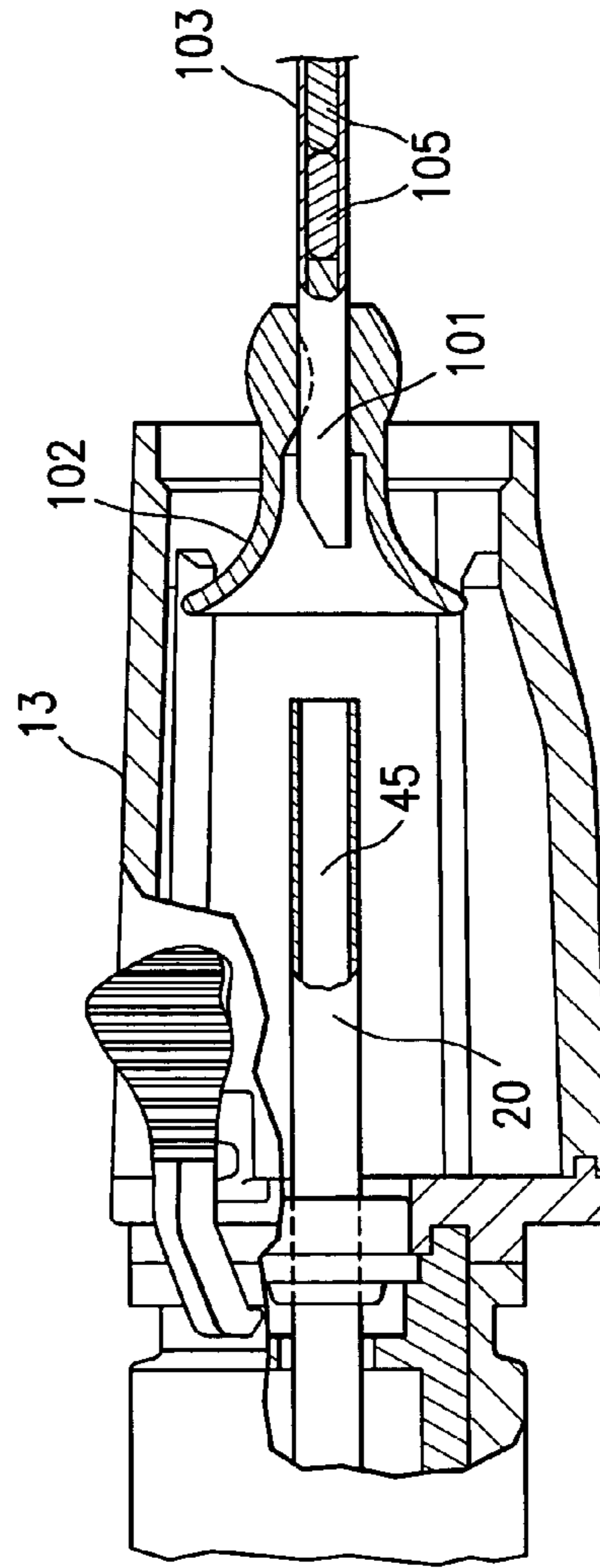

FIG. 23

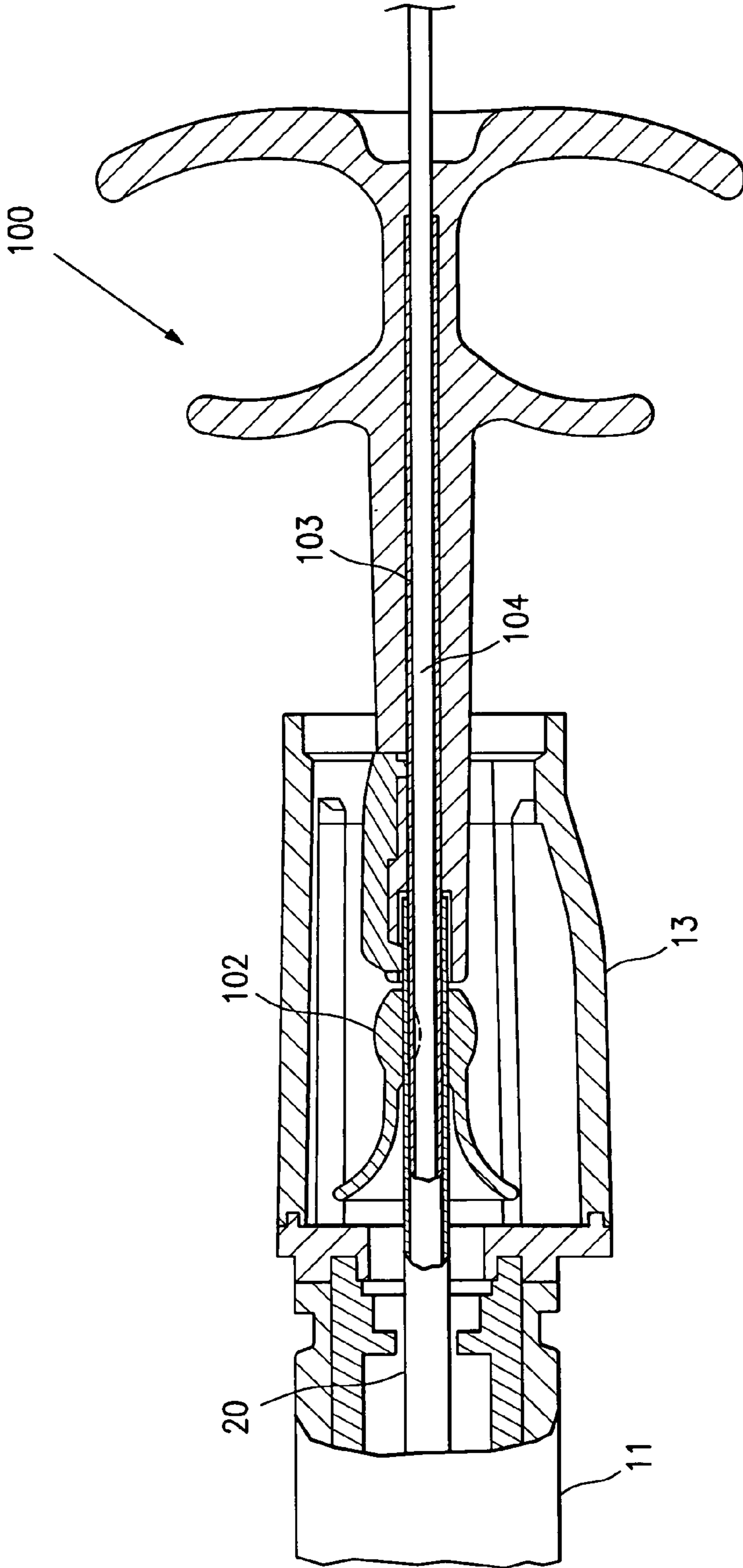

FIG. 24

1

**BIOPSY DEVICE WITH APERTURE  
ORIENTATION AND IMPROVED TIP**

## FIELD OF THE INVENTION

The present invention relates generally to tissue removing devices such as biopsy devices and the methods of using such devices. More specifically, it is directed to an improved device and method for accessing and removing pathologically suspect tissue from within a patient's body.

## BACKGROUND OF THE INVENTION

In diagnosing and treating certain medical conditions, such as potentially cancerous tumors, it is usually desirable to perform a biopsy, in which a specimen of the suspicious tissue is removed for pathological examination and analysis. In many instances, the suspicious tissue is located in a subcutaneous site, such as inside a human breast. To minimize surgical intrusion into the patient's body, it is desirable to be able to insert a small instrument into the patient's body to access the targeted site and to extract the biopsy specimen therefrom.

Electrosurgical techniques have been used in a variety of biopsy procedures. In electrosurgery, high frequency electrical energy is typically applied to patient tissue through an active electrode, the electrical circuit being completed by a return electrode in contact with the patient's tissue. Electrical energy flowing through the tissue from the active electrode is effective to ablate tissue near the active electrode, forming an opening in the tissue and so allowing insertion of the instrument into a patient's body. A return electrode may be placed on the exterior of the patient's body or may be incorporated into the device itself. The return electrode is typically attached to the patient at a point remote from where the primary or active electrode contacts the tissue. However, in the case of a bipolar electrode for example, the return electrode may be disposed near to the active electrode. An electrosurgical biopsy instrument is disclosed and claimed in U.S. patent application Ser. No. 09/159,467 for "Electrosurgical Biopsy Device and Method," now U.S. Pat. No. 6,261,241, assigned to the assignee of the present application, and which is hereby incorporated by reference in its entirety. A variety of needle like tip designs have been developed to aid in the accessing of intracorporeal sites for biopsy and other procedures. Electrosurgical techniques have also been used in a variety of biopsy procedures to gain access to an intracorporeal site. See for example U.S. Pat. No. 6,261,241, assigned to the assignee of the present application, and which is hereby incorporated by reference in its entirety.

The prior needle like tips do not always allow proper placement of the biopsy or other surgical device. Moreover, while the electrosurgical biopsy devices have been found to be effective in many instances, they are not suitable for use in conjunction with magnetic resonance imaging.

While these electrosurgical biopsy devices have been found to be effective in many instances, they may not always be suitable for use in conjunction with magnetic resonance imaging.

## SUMMARY OF THE INVENTION

This invention is directed to devices for accessing and severing tissue from a target site within a patient and methods for utilizing such devices. The devices embodying features of the invention provide access to a targeted tissue site within a

2

patient and provide for the selection, separation and capture of a tissue specimen from supporting tissue at the targeted site.

A tissue accessing and severing device and system having features of the invention generally include an elongated, preferably disposable probe component having a plurality of operative elements and a driver component configured to receive the elongated probe component and drive the various operative elements of the probe component.

The elongated probe component has a distal shaft portion with a tissue penetrating distal tip, a tubular section proximal to the distal tip, an inner lumen extending within the tubular section and an open, tissue receiving aperture in the tubular section which provides access to tissue at the targeted site.

The probe component includes an elongated tissue-cutting member, which is preferably at least in part cylindrically shaped. The tissue cutting member is provided with at least one tissue cutting edge which is configured to sever tissue extending into the interior of the tubular section through the aperture thereof. The cutting edge on the tissue cutting member may be configured for longitudinal cutting movement and may include oscillating rotational motion and/or reciprocating longitudinal motion to sever specimen tissue extending through the aperture from supporting tissue at the targeted site. The cutting surfaces or edges are radially spaced from a longitudinal axis of the probe component and are generally transversely oriented with respect to the longitudinal axis. The tissue cutter is preferably slidably disposed within the inner lumen of the tubular section, although it may be disposed about the tubular section. The probe component may also have a handle which releasably engages the driver component.

In one embodiment of the invention, the cutting member has an inner lumen preferably extending to the proximal end thereof for tissue specimen removal. While mechanical withdrawal of the tissue specimen may be employed, it is preferred to provide a vacuum within the cutting member from the proximal end of the cutting member. The proximal end of the cutting member may be configured to be in fluid communication with a vacuum source to aspirate the severed tissue specimen through the inner lumen of the cutting member to a tissue collection station. A higher fluid pressure may be maintained in the inner lumen of the cutting member distal to the tissue specimen to aid in transporting the specimen proximally through the inner lumen. In this manner, the mechanical withdrawal and/or the vacuum on the proximal end of the specimen and a higher pressure on the distal end of the specimen can move the specimen through the inner lumen of the cutting member to a tissue collection station.

In at least one embodiment, the handle of the probe component is secured, preferably releasably secured, to the driver housing provided to operably connect the various operative elements of the probe with operative elements of the driver component. The tissue cutting member is operatively connected to at least one driver to provide the desired cutting motion. The proximal end of the tubular section is rotatably secured within the handle housing so that the orientation thereof with respect to the longitudinal axis and therefore the orientation of the tissue receiving aperture within the tubular section, can be selected. The orientation of the aperture may be selected manually such as described in copending application Ser. No. 10/642,406, filed Aug. 15, 2003 or it may be preset or selected electronically by a control module which also controls the operation of the cutting member and electrical power. The aperture orientation setting may be selected before or after the distal portion of the probe component is inserted into the patient.

The tissue penetrating distal tip embodying features of the invention has a proximal base secured to the distal end of the probe shaft of the biopsy device, and a sharp distal point distal to the proximal base. The tissue penetrating distal tip has a first concave surface extending from the base to the sharp distal point. The distal tip also has a second concave surface, which intersects the first concave surface forming therewith a first curved cutting edge that leads to the sharp distal point. The distal tip also has a third concave surface which intersects the first concave surface forming therewith a second curved cutting edge leading to the sharp distal point and also intersects the second concave surface forming therewith a third curved cutting edge that leads to the sharp distal point. The concave surfaces preferably have center lines which extend from the proximal base of the distal tip to the sharp distal point. In a presently preferred embodiment the concave surfaces are of the same area. However, they may have different areas.

The driver component has at least two and preferably three driver units for operating the probe component secured to the driver component. Specifically, the driver component has a first driver unit for rotating the tubular section of the probe component, a second driver unit for moving the cutting member along a longitudinal axis of the cutting member and optionally a third driving unit for rotating or oscillating the cutting member about the longitudinal axis. The first driver unit rotates the tubular section of the probe component, preferably in discrete steps, so that the location of the tissue receiving aperture in the distal extremity of the tubular section can be selected prior to or during the procedure. The discrete rotational steps of the tubular section are preferably in 30° or multiples thereof so that the rotational movement will follow 12 hour clock markings. Preferably, the second and third driver units are operable together so that the cutting member may rotate or oscillate about a longitudinal axis as the cutter member is moved longitudinally. This allows a rotation or an oscillation of the cutter during the cutting process which can aid in cutting tissue.

The driver component may have one or more light sources in a distal portion thereof to illuminate the accessing site during the procedure.

A method of cutting and collecting a tissue specimen with a tissue collection device embodying features of the invention includes advancing such a device at least partially into tissue at a desired site within the patient's body with the tissue penetrating distal tip of the outer cannula disposed distal to the tissue specimen to be separated from the target site. A vacuum is established within the inner lumen of the tubular section to draw tissue through the aperture therein into the inner lumen of the tubular section. The cutting member, which is slidably disposed within the inner lumen of the tubular section, may then be moved longitudinally to cut a tissue specimen from supporting tissue at the target site by the longitudinal motion, which preferably includes oscillating rotational movement and/or reciprocating longitudinal movement. The vacuum established within the inner lumen of the tubular section may be applied through the inner lumen of the tissue cutting member when the tissue cutting member is disposed within the tubular section. The applied vacuum within the inner lumen of the tissue cutting member, may also be utilized to pull or aspirate the separated tissue sample proximally. In addition, or alternatively, a higher fluid pressure may be maintained in a distal part of the inner lumen of the tubular section, distal to the specimen, to push the tissue specimen proximally. Alternatively, the tissue specimen may be mechanically withdrawn. Fluid pressure may include pressure from a liquid delivered into the interior of the device,

such as a physiological saline solution, and may include a gas, such as pressurized carbon dioxide, nitrogen or air, delivered into the interior of the device. Access to ambient air can also maintain a sufficiently high pressure differential to move the specimen through the inner lumen of the cutting member. Anesthetic may be injected to the target site through the outer cannula or the inner lumen of the cutting member. Upon removal from the patient, the tissue specimen may then be subjected to pathological examination. After acquisition of a tissue specimen or specimens, the tissue separation system may be repositioned for further tissue separation and collection or it may be withdrawn from the patient.

The tubular section of the probe provides the support for the probe to enable precise location of the accessing port to the desired location at the target site with its radial orientations being preset before the device is introduced into the patient or selected after the tubular section is disposed within the patient. The cutting member quickly and cleanly severs the tissue specimen drawn into the interior of the tubular section through the aperture by the action of the vacuum or otherwise. Upon removal of the tissue specimen, the tissue receiving aperture may be radially repositioned about the longitudinal axis of the tubular section of the probe component so that a plurality of specimens may be taken from the target site. The orientation of the tissue receiving aperture during the procedure may follow a preselected pattern or may be selected by the physician for other selected tissue specimens.

A tissue acquisition system assembly embodying features of the invention may include a device for delivery of one or more marker bodies through a tubular member of a biopsy device such as the tubular cutting member. Such a marker delivery device includes an elongated shaft having an inner lumen and a discharge opening in a distal portion of the elongated shaft, at least one marker body which is disposed within the inner lumen of the elongated shaft, a pusher element which is slidably disposed within the delivery device and which is configured to urge at least one marker body out the discharge opening in the distal portion of the elongated shaft. The marker delivery device has a distally flared guide member which is slidably disposed on the elongated shaft to guide the distal portion of the elongated shaft into a proximal end of the tubular member of a biopsy device. This invention is directed to a tissue penetrating probe tip, particularly for biopsy devices. These devices provide access to a targeted tissue site and provide for the separation and capture of a tissue specimen from supporting tissue at the targeted site.

These and other advantages of the invention will become more apparent from the following detailed description of the invention and the accompanying exemplary drawings.

#### BRIEF DESCRIPTION OF THE DRAWINGS

FIG. 1 is an exploded view of the elongated tissue biopsy system embodying features of the invention.

FIG. 2 is a perspective view of the embodiment shown in FIG. 1 in an assembled condition without a housing cover for the probe component.

FIG. 3 is a side elevational view of the tissue biopsy device shown in the FIG. 2.

FIG. 4A is a longitudinal cross-section of the probe shown in FIG. 3 taken along the lines 4-4 with the tissue cutting element in a withdrawn position.

FIG. 4B is a longitudinal cross-section of the probe shown in FIG. 3 taken along the lines 4-4 with the tissue cutting element in a forward or closed position.

## 5

FIG. 5 is a transverse cross-sectional view of the probe shown in FIG. 4B taken along the lines 5-5.

FIG. 6 is a perspective view of the underside of the probe shown in FIG. 1.

FIG. 7 is an enlarged perspective view of the distal end of the driver unit shown in FIG. 1.

FIG. 8 is an enlarged perspective view of the distal end of the probe housing illustrating a marker element which depicts the orientation of the aperture in the tubular section of the biopsy device.

FIG. 9 is a perspective view of the underside of the driver shown in FIG. 1.

FIG. 10 is an elevational view of a tissue penetrating tip embodying features of the invention.

FIG. 11 is a perspective view of the underside of the tip shown in FIG. 10.

FIG. 12 is a longitudinal, center line cross-sectional view of the penetrating tip shown in FIG. 10.

FIG. 13 is a longitudinal cross-sectional view of the penetrating tip shown in FIG. 12 taken along the lines 13-13.

FIG. 14 is a longitudinal cross-sectional view of the penetrating tip shown in FIG. 12 taken along the lines 14-14.

FIG. 15 is a longitudinal cross-sectional view of the penetrating tip shown in FIG. 3 taken along the lines 15-15.

FIG. 16 is a bottom view of the penetrating tip shown in FIG. 10.

FIG. 17 is a transverse cross-sectional view of the penetrating tip shown in FIG. 16 taken along the lines 17-17.

FIG. 18 is a transverse cross-sectional view of the penetrating tip shown in FIG. 16 taken along the lines 18-18.

FIG. 19 is a transverse cross-sectional view of the penetrating tip shown in FIG. 16 taken along the lines 19-19.

FIG. 20 is a transverse cross-sectional view of the penetrating tip shown in FIG. 16 taken along the lines 20-20.

FIG. 21 is a perspective view of the tissue biopsy system shown in FIG. 1 assembled and mounted on a stereotactic frame.

FIG. 22 is an elevational view of a marker delivery device with a flared guide on the distal end of the shaft which facilitates guiding the distal tip of a marker delivery device into the interior of the proximal end of the tissue cutter.

FIG. 23 is a longitudinal cross-sectional view of the distal end of the marker delivery device and flared guide disposed within the tissue collection component shown in FIG. 1.

FIG. 24 is a longitudinal cross sectional view of the proximal end of the marker delivery device with the flared guide at the proximal end of the shaft and with the shaft deployed within the inner lumen of the tissue cutter.

#### DETAILED DESCRIPTION OF EMBODIMENTS OF THE INVENTION

FIGS. 1-3 illustrate a biopsy system 10 embodying features of the invention which includes a disposable probe component 11, a driver component 12 and specimen collector 13.

The probe component 11 generally includes an elongated distal shaft 14 having a tubular section or cannula 15 with a tissue penetrating tip 16 on the distal end thereof and an open, tissue receiving aperture 17. The probe component 11 also includes a probe housing 18 with a housing cover 19 which is configured to interfit with the driver component 12. A tissue cutter 20 is slidably disposed within the probe and has a distal cutting surface 21 which severs tissue which extends through the tissue receiving aperture 17.

Details of the probe component 11 are further shown in FIGS. 4A and 4B. The probe housing 18 has a mechanical system for rotating the housing and the tubular section 15

## 6

secured thereto to control the angular position of the tissue receiving aperture 17 and for moving the tissue cutter 20 slidably disposed within the probe component 11.

The mechanical system of the driver component 12 has first driving gear 22 that is configured to engage the probe gear 23 and rotate the probe housing 18 so as to adjust the orientation of aperture 17 in the distal extremity of the tubular section 15. The probe gear 23 is secured to the rotating connector body 24 by adhesive 25. The proximal extremity of the tubular section 15 is secured to the rotating connector body 24 by adhesive 26. An end cap 27 retains the connector body 24 within the probe housing 18. Rotation of the probe gear 23 rotates the connector body 24 and the attached tubular section 15. The rotation is preferably controlled so that the tubular section 15 rotates in discrete steps about the longitudinal axis 28 to adjust the angular orientation of the aperture 17 about the longitudinal axis. Preferably these discrete orientations may be provided in increments of 30° which can be readily indicated by arrow 29 at the distal end of the probe housing 18 as shown in FIG. 8.

The second driving gear 30 is configured to drive the tissue cutter 20 longitudinally. The driving gear 30 engages probe gear 31 which drives cutter traverse nut 32 and cutter screw 33 threadably connected to the cutter traverse nut. The distal end of the cutter screw 33 is provided with a recess 34 which receives the rib 35 of the cutter shuttle 36. The cutter shuttle 36 is secured to the tissue cutter 20 by adhesive 37. The probe gear 31 is secured to the cutter traverse nut 32 by adhesive 38. Rotation of the probe gear 31 adjusts the relative axial position of the cutter screw 33 with respect to the cutter traverse nut 32 which is secured to the cutter shuttle 36. Longitudinal movement of the tissue cutter 20 follows the longitudinal movement of the cutter shuttle 36 resulting from the movement of cutter screw 33. The length of the tissue receiving aperture 17, and as a result the length of the specimen, can be controlled by adjusting the initial longitudinal position of the distal end of the tissue cutter 20 within the aperture, before cutting.

The third driving gear 40 is configured to rotate or oscillate the tissue cutter 20 as the cutter moves along the longitudinal axis 28 to facilitate the cutting action of the cutting surface 21 on the distal end of the cutter. The third driving gear 40 engages probe gear 41 which is secured to cutter oscillation shaft 42 by adhesive 43. The probe gear 41 may be oscillated back and forth about the longitudinal axis 28 or rotated continuously in a single direction about the longitudinal axis, or both depending upon the desired rotational movement of the tissue cutter.

A biased valve assembly 44 is provided in the distal end of the probe housing 18 to ensure sealing when a vacuum is developed within the interior 45 of the tissue cutter 20 while providing an atmospheric vent 46 between the interior surface 47 of the tubular section 15 and the exterior surface 48 of the tissue cutter 20. The valve assembly 44 includes a spring 49, valve body 50 and a valve collar 51 which is secured to the proximal end of the tubular section 15 by adhesive 52. The proximal end of the valve spring 49 rests against the shoulder 53 provided in the exterior of the valve body 50. A biased cutter shaft seal 54 slidably engages the exterior 48 of the tissue cutter 20.

The tissue specimen collector 13 is secured to the proximal end of the housing of probe component 11 and has an interior 55 in fluid communication with the inner lumen 56 extending within the tissue cutter 20 and has a removable proximal wall 57 of specimen receiving cartridge 58 which gives access to the interior 55 and any tissue specimens which may have been drawn therein. A vacuum is generated within the interior 55 to

draw tissue specimens through the inner lumen **45** into the interior **55**. Tubular member **59** has a distal end which is in fluid communication with the interior **55** of the tissue specimen collector **13** and has a proximal end (not shown) which is configured to be connected to a vacuum source. Application of a vacuum within the tubular member **59** aids in pulling tissue into the interior **17** of the tubular section **15** and transfer of the severed tissue specimen through the inner lumen **45** of the tissue cutter **20** to the specimen cartridge **58**.

The driver **12** has a housing **60** with an upper concave surface **61** which is configured to receive the lower surface **62** of the probe housing **18**. Three partially exposed driving gears **22**, **30** and **40** are provided on the proximal end of the driver **12** which are configured to engage the probe gears **23**, **31** and **41** respectively. The drive **12** is provided with three separately operating drive motors (not shown) which drive the drive gears **22**, **30** and **40**. The separate drive motors (not shown) are connected to and the operation thereof controlled by a control module, such as described in copending application Ser. No. 10/847,699, filed on May 17, 2004. The control module controls the motors which move the individual drive gears **22**, **30** and **40**. The gear **22** engages gear **23** in the probe **11** to control the rotation of the probe housing **18** and the location and orientation of the tissue receiving aperture **17**. The drive gear **30** engages probe gear **31** to control the longitudinal position and motion of the tissue cutter **20** along the longitudinal axis **28**. Drive gear **40** engages probe gear **41** to control the oscillation or rotation of the tissue cutter **20** about the longitudinal axis **28**.

As shown in FIG. 7, the front face of the driver component **12** is provided with light sources **66** and **67** and a manually activatable switch **68** to activate the light sources and enable the physician and other operating personnel to better view the operating site on the patient. Other manual switches, e.g. a foot activated switch, may be employed. Alternatively, the light sources may be automatically activated when the probe component **11** is installed on the driver **12** or other events such as when electrical power is turned on. The driver component **12** may have a battery pack for the light sources **66** and **67**.

The tissue penetrating distal tip **16** may have a variety of tip shapes. A particularly suitable distal tip embodying features of the invention is shown in FIGS. 9-20. The tissue penetrating distal tip generally includes a base **70**, a sharp distal point **71**, a first concave surface **72**, a second concave surface **73** and a third concave surface **74**.

The intersection between the first concave surface **72** and the second concave surface **73** forms the first curved cutting edge **75**. The intersection between the second concave surface **73** and the third concave surface **74** forms the second curved cutting edge **76**. The intersection between the third concave surface and the first concave surface **72** forms the third curved cutting surface **77**.

The concave surfaces **72**, **73** and **74** are hollow ground and the penetrating tip **16** is then electro-polished to increase the sharpness of the cutting edges **75**, **76** and **77**. The penetrating distal tip **16** may be formed of suitable surgical stainless steel such as 17-4 stainless steel. Other materials may be suitable. The penetrating distal tip **16** is preferably electro-polished in an acidic solution to sharpen the curved cutting edges and thereby facilitate tissue penetration. Suitable electro-polishing solutions include Electro Glo sold by the Electro Glo Distributing Co.

The base **70** of the tissue penetrating tip **16** may be secured to the distal end of the elongated shaft of the biopsy device **10** for accessing and collecting tissue from a target site within a patient. The sharp distal tip **16** embodying features of the invention readily penetrates a patient's tissue, particularly

breast tissue and facilitates guiding the distal end of the biopsy or other device to a desired intracorporeal location.

The tissue penetrating tips may also be employed on biopsy devices such as those described in co-pending application Ser. No. 10/642,406, filed on Aug. 15, 2003, which is assigned to the present assignee. Alternatively, the distal tip may be provided with an arcuate RF electrode such as disclosed in U.S. Pat. Nos. 6,261,241, and 6,471,700, both assigned to the present assignee.

The separate driver component **12** allows the probe unit **11** to be disposable. The drive gears of the drive component **12** control the motion of the tissue cutting member **20** for cutting and the motion of the tubular section **15** to orient the aperture **17**. Other means (not shown) may provide mechanical and electrical power, vacuum, and control to the probe device. Examples of replaceable snap-in type probe units are disclosed in Burbank et al., U.S. patent application Ser. No. 10/179,933, "Apparatus and Methods for Accessing a Body Site". Drive units such as that described in WO 02/069808 (which corresponds to co-pending U.S. application Ser. No. 09/707,022, filed Nov. 6, 2000 and U.S. application Ser. No. 09/864,021, filed May 23, 2001), which are assigned to the present assignee, may be readily modified by those skilled in the art to accommodate the movement of the cutting member **20**.

In use, the distal end of the probe component **11** is advanced within the patient with the tissue cutter **20** in a forward or closed position (FIG. 4B), until the aperture **17** of the tubular section **15** is located in a desired location for taking a tissue specimen. The tissue cutter **20** is then withdrawn proximally to an open position to open the aperture **17**. The withdrawal of the tissue cutter can be used to control the length of the aperture which is opened in order to control the length of the specimen which is severed. A vacuum is applied to the interior **45** of the tissue cutter **20** to draw tissue at the site into the inner lumen of the tubular section **15** through the aperture **17**. The tissue cutter **20** is then driven distally by rotation of probe gear **30** and rotated or oscillated by drive gear **40** engaging probe gear **41** to sever the aspirated tissue from the supporting tissue at the target site with the tissue cutting surface **21**. The vacuum within the interior of the tissue cutter **20** causes the tissue specimen to be drawn through the inner lumen **45** of the tissue cutter **20** and into the cartridge **58** of specimen collector **13** shown in FIG. 2. Positive pressure or even ambient conditions distal to the tissue specimen can facilitate tissue passing through the interior **45** of tissue cutter **20**. If another tissue specimen is desired, the tubular section **15** may be rotated by the drive gear **22** engaging the probe gear **23** in one or more steps to repeat obtaining another tissue specimen in the same manner without otherwise moving the probe component **11**. Typically, a first tissue specimen is obtained with the aperture **17** of the probe **11** in the 12 o'clock position, the second at the 3 o'clock position, the third at the 9 o'clock position and the fourth at the 6 o'clock position. The location of the second and third specimens may be reversed. The position of the aperture **17** may be indicated by a marker arrow **29** at the end cap **27** so that the physician or other operating personnel can readily determine what the orientation of the aperture **17** within the patient.

The biopsy system **10** may be hand held for some biopsy procedures or the system may be mounted on a stereotactic mounting stage **80** as shown in FIG. 21. A shoe **81** is slidably mounted to a rail **82** of a Fisher stage. The mounting member **83** is secured to the shoe **81** by a threaded post (not shown) secured to thumbwheel **84**. As shown in FIG. 10, the bottom surface **85** of the driver component **12** is configured to conform at least in part to the upper surface of the mounting

member **83**. The sampling and vacuum switches **86** and **87** respectively on the driver component **12** are actuated by the optional sampling and vacuum actuating elements **88** and **89** on the mounting member **83**. Alternatively, sampling and vacuum may be actuated with a foot pedal. As shown in FIG. **22**, the driver component has an operator dial **90** which when turned opens a threaded hole **91** for receiving a threaded post (not shown) secured to the thumbwheel **84** and the locating pin holes **92** and **93** which receive the complementary posts (not shown) in the mounting member **83**.

As mentioned above, positive pressure or even ambient conditions will aid in passing the severed tissue specimen through the inner lumen **45** of tissue cutter **20** into the cartridge **58** of specimen collector **13**. As shown in FIGS. **4A** and **4B** venting valve can provide ambient pressure behind the tissue specimen in the cutter interior **45** from the interior of the tubular section **15**. The valve body **50** is opened for atmospheric venting when the tissue cutter **20** is in the forward position upon the completion of severing the specimen from the tissue site. However, when the tissue cutter **20** is pulled back proximally the valve spring **49** urges the valve body **50** back to a closed position. While the tissue cutter **20** is shown with a tissue cutting surface **21** which is perpendicular to the longitudinal axis **28**, the tissue cutting surface may be at an angle or even parallel to the longitudinal axis as described in co-pending application Ser. No. 10/642,406, filed Aug. 15, 2003.

The distal cutting edge **21** of the tissue cutter **20** may initially be located proximal to the aperture **17** to provide a full aperture for receiving tissue or it can be initially located within the aperture **17** in order to control the length of the specimen. The cutting action of tissue cutter **20** preferably continues until the beveled cutting surface **21** has completely traversed the aperture **17** to ensure that the tissue drawn through the aperture is completely severed from supporting tissue at the biopsy site. A vacuum may be applied to aspirate the severed tissue specimen through the inner lumen of the tissue cutter **20** to the cartridge in the specimen collector at the proximal end of the biopsy device. Positive pressure or access to ambient conditions may be provided in the distal end of the tubular section to aid in the specimen transfer.

After the removable wall **57** of the specimen receiving cartridge **58** is removed and the specimens therein removed, it is frequently desirable to deliver one or more markers to the target site from which the specimens have been removed. Such marker delivery devices are shown in co-pending application Ser. No. 10/753,694, filed on Jan. 7, 2004 and co-pending application Ser. No. 10/444,770, filed May 23, 2003. However, the distal ends of these marker delivery devices are very small and they can be difficult to insert into the proximal end of the tissue cutter **20** which is just slightly larger to accommodate the marker delivery shaft.

FIG. **22** illustrates a marker delivery device **100** which is particularly suitable to facilitate the introduction of the distal end of the shaft **101** into the inner lumen **45** of the tissue cutter **20** and the advancement therein. As shown in FIG. **23**, to facilitate the insertion of the small diameter distal tip **101** of the marker delivery device **100** into the slightly larger inner lumen **45** of the tubular cutter **20** at its proximal end, the distal tip is preferably provided with an outwardly flared guide **102** which is slidably mounted on the shaft **103** of the marker delivery device **100**. The proximal end of the tubular cutter **20**, the flared guide **102** and/or the distal tip **101** may be provided with mating guide elements which orient the marker delivery device with the cannula **15** of the biopsy device. To ensure that one or more markers are discharged through the aperture **17** of the biopsy device **10** when the pusher element

slidably disposed within the delivery device is urged distally to press at least one marker body out the discharge opening in the distal portion of the elongated shaft of the marker delivery device. As indicated in FIG. **23**, the shaft **103** of the marker delivery device **100** is advanced into the inner lumen **45** of the tissue cutter **20** so that the distal end **101** of the marker delivery device **100** is adjacent to the aperture **17** of the cannula **15**. Plunger **104** is pressed further into the inner lumen of shaft **103** to eject one or more markers **105** through the aperture **17** in the tubular section **15** before the biopsy device **10** is removed from the patient. The delivery of markers to the target site after specimen removal, while the distal end of the biopsy device is still at the biopsy site, ensures that the markers are properly position at the biopsy site.

While the slidably mounted, flared proximal guide **102** is described with respect to being disposed on the shaft **103** of marker delivery device **101**, the flared guide **102** has wide application within a variety of biopsy and other devices where one small diameter tubular member is to be inserted into a slightly larger, but still small diameter second tubular member.

The elongated probe component **11** of the biopsy system **10** has a length of about 3 to about 20 cm, preferably, about 5 to about 13 cm, and more specifically, about 8 to about 9 cm for breast biopsy use. To assist in properly locating the probe **11** during advancement thereof into a patient's body, the distal extremity of the tubular section may be provided with a marker at a desirable location that provide enhanced visualization by eye, by ultrasound, by X-ray, MRI or other imaging or visualization means. Manual palpation may also be employed. An echogenic polymer coating that increases contrast resolution in ultrasound imaging devices (such as ECHOCOAT™ by STS Biopolymers, of Henrietta, N.Y.) is suitable for ultrasonic visualization. Radiopaque markers may be made with, for example, stainless steel, platinum, gold, iridium, tantalum, tungsten, silver, rhodium, nickel, bismuth, other radiopaque metals, alloys and oxides of these metals. In addition, the surfaces of the device in contact with tissue or other components of the device may be provided with a suitable lubricious coating such as a hydrophilic material or a fluoropolymer.

The tubular section and the tissue cutter are preferably formed of a surgical grade stainless steel. However, other high strength materials such as MP35N, other cobalt-chromium alloys, NiTi alloys, ceramics, glasses, and high strength polymeric materials or combinations thereof may be suitable.

A patient's skin usually must be breached in order to gain access to a body site where a tissue specimen is to be obtained. A scalpel or other surgical instrument may be used to make an initial incision in the skin. After the specimens have been taken, the biopsy device may be removed from the patient. The entire device may be removed; however, in some embodiments, the cartridge **58** may be removed from the system **10** and a delivery cannula may be inserted through the inner lumen of the cutter **20** to deliver markers to the biopsy site through the aperture **17**. In addition, it will be readily appreciated that other types of instruments may be inserted into the tissue site through the tissue cutter in addition to or in place of the instruments described above. Moreover, therapeutic or diagnostic agents may be delivered through the tissue cutter **20** or the tubular section **15**.

While particular forms of the invention have been illustrated and described herein, it will be apparent that various modifications and improvements can be made to the invention. For example, while the various embodiments of the invention have been described herein in terms of a biopsy device, it should be apparent that the devices and methods of

## 11

utilizing the device may be employed to remove tissue for purposes other than for biopsy, i.e. for treatment or other diagnoses. Additionally, the tissue penetrating distal tip design may be employed on probes for other uses. Other modifications include, for example, a tissue cutter slidably mounted around the tubular section of the probe component rather than within the tubular section. Moreover, individual features of embodiments of the invention may be shown in some drawings and not in others, but those skilled in the art will recognize that individual features of one embodiment of the invention can be combined with any or all the features of another embodiment. Accordingly, it is not intended that the invention be limited to the specific embodiments illustrated.

Terms such as “element”, “member”, “device”, “section”, “portion”, “means”, “step” and words of similar import, when used in the following claims, shall not be construed as invoking the provisions of 35 U.S.C. §112(6) unless the claims expressly use the term “means” followed by a particular function without specific structure or the term “step” or “steps” followed by a particular function without specific action. All patents and patent applications referred herein are incorporated by reference in their entirety.

What is claimed is:

1. A tissue penetrating element that facilitates advancement through soft tissue to a desired intracorporeal location, comprising:

- a. a proximal base;
- b. a centrally located sharp distal point distal to the proximal base and located on a central longitudinal axis;
- c. a first concave surface that extends from the sharp distal point to the proximal base;
- d. a second concave surface that extends from the sharp distal point to the proximal base and which intersects the first concave surface forming therewith a first continuous curved tissue cutting edge that lies in a first plane parallel to and passing through the central longitudinal axis and extends proximally from the sharp distal point to the proximal base; and
- e. a third concave surface that extends from the sharp distal point to the proximal base and which intersects the first concave surface forming therewith a second continuous curved tissue cutting edge that lies in a second plane parallel to and passing through the central longitudinal axis and extends proximally from the sharp distal point to the proximal base.

2. The tissue penetrating element of claim 1 wherein the curved cutting edges are electro-polished in an acid solution.

3. The tissue penetrating element of claim 1 wherein the first, second and third surfaces have center lines which extend from the base to the sharp distal point.

4. The tissue penetrating element of claim 1 wherein the first, second and third surfaces are equi-spaced about a longitudinal axis of the probe tip.

## 12

5. The tissue penetrating element of claim 1 wherein the concave surfaces have essentially the same surface area.

6. The tissue penetrating element of claim 1 wherein the concave surfaces have essentially the same concavity.

7. The tissue penetrating element of claim 1, wherein a respective longitudinal extent of each of the first concave surface, the second concave surface, and the third concave surface is greater than a respective longitudinal extent of each of the first continuous curved tissue cutting edge, the second continuous curved tissue cutting edge, and the third continuous curved tissue cutting edge.

8. A device for accessing and collecting tissue from a target site within a patient, comprising:

- a. an elongated probe which has a central longitudinal axis, which has a proximal end configured to be secured to a drive, which has an inner lumen extending therein, which has a distal end and which has an aperture proximal to the distal end configured to receive tissue from the target site;
- b. a tissue penetrating tip on the distal end which facilitates advancement through soft tissue to a desired intracorporeal location and has
  - i. a proximal base secured to the distal end of the elongated probe,
  - ii. a centrally located sharp distal point distal to a proximal base,
  - iii. a first concave surface having a center line extending from the sharp distal point to the proximal base,
  - iv. a second concave surface which has a center line extending from the sharp distal point to the proximal base and which intersects the first concave surface forming therewith a first continuous curved tissue cutting edge that lies in a first plane parallel to and passing through the central longitudinal axis and extends proximally from the sharp distal point to the proximal base, and
  - v. a third concave surface which has a center line extending from the base to the sharp distal point and which intersects the first concave surface forming therewith a second continuous curved tissue cutting edge that lies in a second plane parallel to and passing through the central longitudinal axis and extends distally from the sharp distal point to the proximal base and which intersects the second concave surface forming therewith a third continuous curved tissue cutting edge that lies in a third plane parallel to and passing through the central longitudinal axis and extends proximally from the sharp distal point to the proximal base; and
- c. a tissue cutting means which is disposed within the elongated probe and which is configured to cut a tissue specimen from tissue extending into the tissue receiving aperture of the elongated probe.

9. The device of claim 6, wherein a respective longitudinal extent of each of the first concave surface, the second concave surface, and the third concave surface is greater than a respective longitudinal extent of each of the first continuous curved tissue cutting edge, the second continuous curved tissue cutting edge, and the third continuous curved tissue cutting edge.

\* \* \* \* \*