



US009402733B1

(12) **United States Patent**
To et al.

(10) **Patent No.:** **US 9,402,733 B1**
(45) **Date of Patent:** **Aug. 2, 2016**

(54) **STABILIZED,
LATEROVERTICALLY-EXPANDING FUSION
CAGE SYSTEMS**

4,997,432 A 3/1991 Keller
5,192,327 A 3/1993 Brantigan
5,221,261 A 6/1993 Termin et al.
5,609,635 A 3/1997 Michelson
5,976,187 A 11/1999 Richelsoph
5,980,522 A 11/1999 Koros
5,980,552 A 11/1999 Pinchasik et al.
6,039,761 A 3/2000 Li et al.

(71) Applicant: **OUROBOROS MEDICAL, INC.**,
Fremont, CA (US)

(72) Inventors: **John To**, Newark, CA (US); **John J.
Flynn**, Walnut Creek, CA (US)

(Continued)

(73) Assignee: **INTEGRITY IMPLANTS, INC.**,
Jupiter, FL (US)

FOREIGN PATENT DOCUMENTS

(*) Notice: Subject to any disclaimer, the term of this
patent is extended or adjusted under 35
U.S.C. 154(b) by 0 days.

EP 1011503 2/1998
EP 1233732 2/2001

(Continued)

OTHER PUBLICATIONS

(21) Appl. No.: **14/701,013**

U.S. Appl. No. 61/737,054, filed Dec. 15, 2013.

(22) Filed: **Apr. 30, 2015**

(Continued)

Related U.S. Application Data

(63) Continuation of application No. 14/600,617, filed on
Jan. 20, 2015, now Pat. No. 9,060,876.

Primary Examiner — Ellen C Hammond

Assistant Examiner — Christina Negrellirodrigue

(51) **Int. Cl.**
A61F 2/44 (2006.01)
A61F 2/46 (2006.01)

(74) *Attorney, Agent, or Firm* — Brian S. Boyer; Syndicated
Law, PC

(52) **U.S. Cl.**
CPC *A61F 2/442* (2013.01); *A61F 2/4611*
(2013.01)

(57) **ABSTRACT**

(58) **Field of Classification Search**
CPC *A61F 2/442*; *A61F 2/4425*; *A61F 2/447*;
A61F 2/4455; *A61F 2002/443*
USPC 606/246–249; 623/17.11–17.16
See application file for complete search history.

An intervertebral scaffolding system is provided having a laterovertically-expanding frame operable for a reversible collapse from an expanded state into a collapsed state, the laterovertically-expanding frame having a stabilizer that slidably engages with the distal region of the laterovertically-expanding frame and is configured for retaining the laterovertically-expanding frame from a lateral movement that exceeds the expanded state. The expanded state, for example, can be configured to have an open graft distribution window that at least substantially closes upon the reversible collapse.

(56) **References Cited**

U.S. PATENT DOCUMENTS

4,309,777 A 1/1982 Patil
4,733,665 A 3/1988 Palmaz
4,759,766 A 7/1988 Buettner-Janz et al.
4,820,305 A 4/1989 Harms et al.

20 Claims, 21 Drawing Sheets

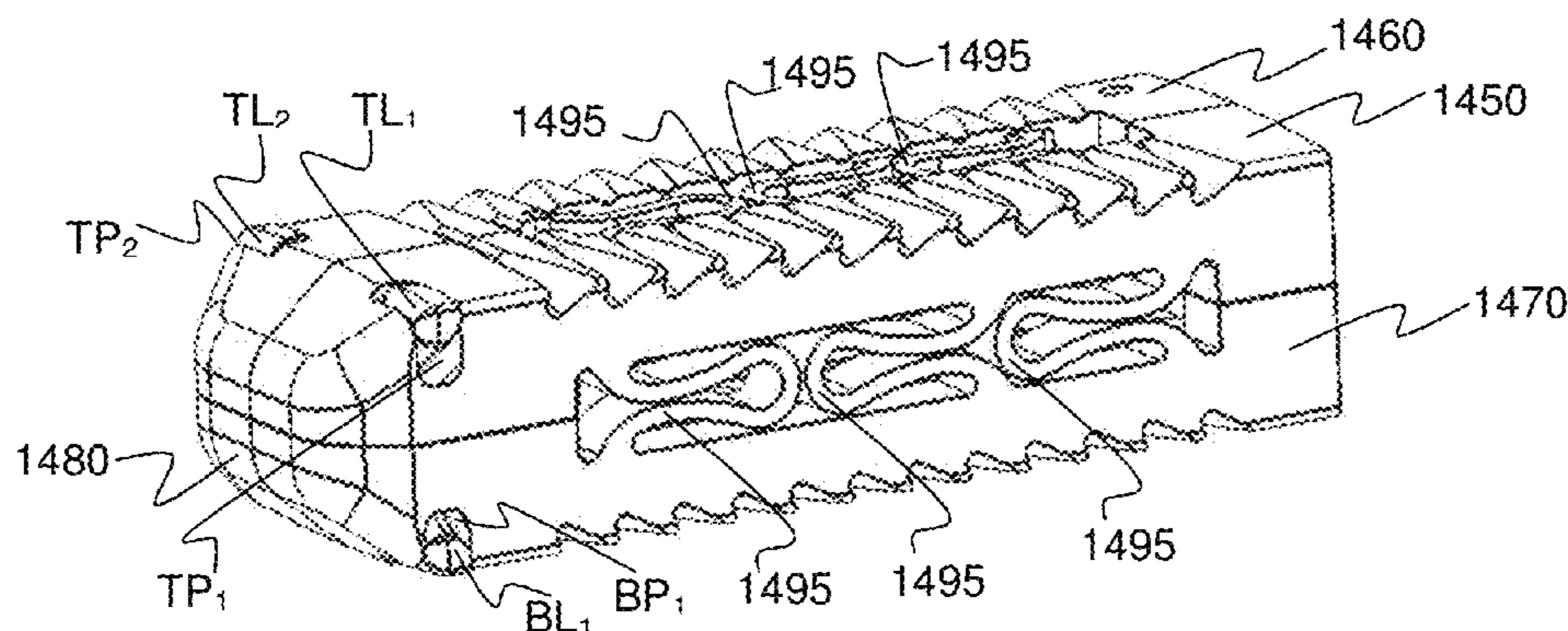

(56)

References Cited

U.S. PATENT DOCUMENTS

6,193,757 B1 2/2001 Foley et al.
 6,368,351 B1 4/2002 Glenn et al.
 6,395,031 B1 5/2002 Foley et al.
 6,409,766 B1* 6/2002 Brett A61F 2/4455
 623/17.15
 6,419,705 B1 7/2002 Erickson
 6,432,107 B1 8/2002 Ferree
 6,443,989 B1 9/2002 Jackson
 6,482,235 B1 11/2002 Lambrecht et al.
 6,488,710 B2 12/2002 Besselink
 6,575,899 B1 6/2003 Foley et al.
 6,582,467 B1 6/2003 Teitelbaum
 6,595,998 B2 7/2003 Johnson et al.
 6,666,891 B2 12/2003 Boehm, Jr. et al.
 6,821,276 B2 11/2004 Lambrecht et al.
 6,893,464 B2 5/2005 Kiester
 7,018,415 B1 3/2006 McKay
 7,083,650 B2 8/2006 Moskowitz et al.
 7,087,055 B2 8/2006 Lim et al.
 7,214,243 B2 5/2007 Taylor
 7,217,293 B2 5/2007 Branch
 7,544,208 B1 6/2009 Mueller et al.
 7,621,950 B1 11/2009 Globerman et al.
 7,655,046 B2 2/2010 Dryer et al.
 7,678,148 B2 3/2010 Peterman
 7,771,473 B2 8/2010 Thramann
 D626,233 S 10/2010 Cipoletti et al.
 7,819,921 B2 10/2010 Grotz
 7,828,845 B2 11/2010 Estes et al.
 7,846,206 B2 12/2010 Oglaza et al.
 7,850,733 B2 12/2010 Baynham et al.
 7,862,618 B2 1/2011 White et al.
 7,879,098 B1 2/2011 Simmons, Jr.
 7,909,872 B2 3/2011 Zipnick
 8,062,375 B2 11/2011 Glerum et al.
 8,070,754 B2 12/2011 Fabian et al.
 8,070,813 B2 12/2011 Grotz et al.
 8,083,744 B2 12/2011 Dorchak
 8,088,163 B1 1/2012 Kleiner
 8,105,382 B2 1/2012 Olmos et al.
 8,110,004 B2 2/2012 Valdevit et al.
 8,123,755 B2 2/2012 Johnson et al.
 8,167,950 B2 5/2012 Aferzon et al.
 8,182,538 B2 5/2012 O'Neil et al.
 8,187,332 B2 5/2012 McLuen
 8,236,058 B2 8/2012 Fabian et al.
 8,241,363 B2 8/2012 Sommerich et al.
 8,267,939 B2 9/2012 Cipoletti et al.
 8,303,658 B2 11/2012 Peterman
 8,353,961 B2 1/2013 McClintock
 8,353,963 B2 1/2013 Glerum
 8,551,173 B2* 10/2013 Lechmann A61F 2/3094
 623/17.12
 8,663,332 B1 3/2014 To et al.
 8,986,387 B1 3/2015 To et al.
 2002/0040243 A1 4/2002 Attali
 2002/0138146 A1 9/2002 Jackson
 2003/0074075 A1 4/2003 Thomas et al.
 2003/0083746 A1 5/2003 Kuslich
 2004/0010315 A1 1/2004 Song
 2004/0024463 A1 2/2004 Thomas et al.
 2006/0100706 A1 5/2006 Shaddock
 2006/0149385 A1 7/2006 McKay
 2006/0287729 A1 12/2006 Segal et al.
 2007/0118222 A1 5/2007 Lang
 2007/0173939 A1 7/2007 Kim et al.
 2007/0219634 A1 9/2007 Greenhalgh
 2007/0265627 A1 11/2007 Dorchak
 2008/0009876 A1 1/2008 Sankaran et al.
 2008/0021556 A1 1/2008 Edie
 2008/0021559 A1 1/2008 Thramann
 2008/0147193 A1 6/2008 Matthis
 2008/0234687 A1 9/2008 Schaller
 2008/0281346 A1 11/2008 Greenhalgh
 2009/0018524 A1 1/2009 Greenhalgh

2009/0076607 A1 3/2009 Aalsma et al.
 2009/0138083 A1 5/2009 Biyani
 2009/0222043 A1 9/2009 Altarac
 2009/0222100 A1 9/2009 Cipoletti et al.
 2009/0234389 A1 9/2009 Chuang
 2010/0010633 A1 1/2010 Kohm
 2010/0198352 A1 8/2010 Edie
 2010/0217325 A1 8/2010 Hochschuler
 2010/0222884 A1 9/2010 Greenhalgh
 2010/0234956 A1 9/2010 Attia
 2010/0286783 A1 11/2010 Lechmann et al.
 2010/0292796 A1 11/2010 Greenhalgh
 2011/0022090 A1 1/2011 Gordon
 2011/0029082 A1 2/2011 Hall
 2011/0046748 A1 2/2011 Martin
 2011/0093074 A1 4/2011 Gelerum
 2011/0130835 A1 6/2011 Ashley
 2011/0172774 A1 7/2011 Varela
 2011/0190816 A1 8/2011 Sheffer
 2011/0282453 A1 11/2011 Greenhalgh
 2011/0301712 A1 12/2011 Palmatier
 2011/0319997 A1 12/2011 Glerum
 2012/0029636 A1 2/2012 Ragab
 2012/0035729 A1 2/2012 Glerum et al.
 2012/0046748 A1 2/2012 Weiman
 2012/0059470 A1 3/2012 Weiman
 2012/0083889 A1 4/2012 Purcell
 2012/0089185 A1 4/2012 Gabelberger
 2012/0109319 A1 5/2012 Perisic
 2012/0209386 A1 8/2012 Triplett et al.
 2012/0271396 A1 10/2012 Zheng
 2012/0277878 A1 11/2012 Sommerich
 2012/0290090 A1 11/2012 Glerum et al.
 2012/0303126 A1 11/2012 Kirschman
 2013/0023996 A1 1/2013 McCormack
 2013/0184822 A1 7/2013 Kleiner
 2014/0039625 A1 2/2014 To et al.
 2014/0172106 A1 6/2014 To et al.
 2015/0073555 A1 3/2015 To et al.

FOREIGN PATENT DOCUMENTS

EP 2327377 3/2002
 EP 1532949 11/2003
 EP 2237748 1/2009
 WO WO 96/40015 6/1996
 WO WO 00/44319 1/2000
 WO WO 01/66047 7/2001
 WO WO 2008/005627 1/2008
 WO WO 2008/035849 3/2008
 WO WO 2008/089252 7/2008
 WO WO 2008/121162 10/2008
 WO PCT/US2013/052799 7/2012
 WO PCT/US2013/073435 12/2013
 WO PCT/US2014/054437 2/2014

OTHER PUBLICATIONS

U.S. Appl. No. 61/875,688, filed Oct. 4, 2013.
 U.S. Appl. No. 14/600,617, filed Jan. 20, 2015.
 U.S. Appl. No. 14/622,864, filed Feb. 26, 2014.
 Search report for PCT/US2013/052799, Dec. 2, 2012.
 Written opinion and search report for PCT/US2013/073435, Apr. 30, 2012.
 Written opinion and search report for PCT/US2014/054337, Jan. 6, 2015.
 Basho, R. et al. Lateral interbody fusion: Indications and techniques. Operative techniques in orthopaedics 21(3): 204-207 (Sep. 2011).
 Caliber. www.globusmedical.com [online] URL: http://www.globusmedical.com/mis/166-caliber [retrieved on Jul. 27, 2012].
 Cole, D. et al. Comparison of low back fusion techniques: transforaminal lumbar interbody fusion (TLIF) or posterior lumbar interbody fusion (PLIF) approaches. Curr rev Musculoskelet med 2(2): 118-126 published online Apr. 29, 2009 Doi: 1007/s12178-009-9053-B10 [retrieved Jun. 2009].
 Capstone® Peek spinal system PLIF and TLIF surgical technique. Medtronic Sofamor Danek 1-36 (2009).

(56)

References Cited

OTHER PUBLICATIONS

Coalign. Introducing AccuLIF expandable lumbar interbody fusion technology. [online] URL: <http://www.coalign.com> [retrieved on Jul. 27, 2012].

Chapman, C. A. Design of an expandable intervertebral cage utilizing shape memory alloys. University of Toledo and OhioLINK, 2011. [online] URL: http://etd.ohiolink.edu/view.cgi?acc_num=toledo1302226375 [retrieved Feb. 13, 2013].

Dorso-Lumbar Vertebral Body Cages DSC, Sintea Plustek. [online] URL: http://www.sinteaplustek.com/spine_dsc_eng.html [retrieved on Feb. 13, 2013].

Interbody Fusion Cage (Neo IC) Source, www.tradekorea.com [online] URL: http://www.tradekorea.com/product-detail/P00015150/Interbody_Fusion_Cage_Neo_IC_.html [retrieved Feb. 13, 2013].

Kaech, D.L. et al. Spinal restabilization procedures, diagnostic and therapeutic aspects of intervertebral fusion cages, artificial discs and mobile implants. Elsevier Science B.V. Part II: 121-204(2002).

Kiapour, A. et al. A biomechanical finite element study of subsidence and migration tendencies in stand-alone fusion procedures—comparison of an in situ expandable device with a rigid device. *J Spine* 1(4): 5 pages (2012).

Le Huec, J.C. et al. Endoscope surgery of the spine, a review of 4 years? *Practise, maltrise orthopaedique*. Jan. 1999 [online] URL: http://www.maitrise-orthop.com/viewPage_us.do?id=435 [retrieved on Feb. 5, 2013].

Powerbuilt. Powerbuilt 940378 medium tailpipe expander set. [online] URL: <http://www.amazon.com/Powerbuilt-940377-Tailpipi-Expander-Series/dp/B004KED6A> [retrieved on Feb. 17, 2013].

PR Newswire. Benvenue Medical starts enrolling patients in the post-market lift study on the luna interbody spacer system for degenerative disc disease. Mar. 20, 2012, [online] URL: <http://www.prnewswire.com/news-releases/benvenue-medical-starts-enrolling-patients-in-the-post-market-lift-study-on-the-luna-interbody-spacer-system-for-degenerative-disc-disease-143441246.html> [retrieved on Jan. 27, 2013].

Sasani, M. et al. Single-stage posterior corpectomy and expandable cage placement for treatment of thoracic or lumbar burst fractures. *Spine* 34(1): E33-E40 (Jan. 1, 2009).

Spineology. OptiMesh 1500E deploying grafting system. [online] URL: http://www.spineology.com/fb/intl/products/products/optimesh_1500e.html (retrieved Jun. 3, 2013).

Staxx XD, www.spinewave.com. [online] URL: http://www.spinewave.com/products/xd_us.html [retrieved on Jan. 27, 2013].

Synfix-LR System. Instruments and implants for stand-alone anterior lumbar interbody fusion (ALIF). Synthes SynFix-LR system technique guide 52 pages (2010).

Transforaminal Lumbar Interbody Fusion (TLIF). Virginia spine institute, Reston Virginia. [online] URL: <http://www.spinemd.com/operative-treatments/tlif-transforaminal-lumbar-interbody-fusion.com> 1-6 (2013). [retrieved on Jun. 16, 2013].

Uchida, K. et al. Anterior expandable strut cage replacement for osteoporotic thoracolumbar vertebral collapse. *J Neurosurg Spine* 4(6): 454-462 (Jun. 2006).

Xenos. Cage mesh system for spine. Biotek Chetan Meditech Pvt. Ltd. [online] URL: <http://www.biotekortho.net/spine-treatment.html> [retrieved on Feb. 13, 2013].

Zeus-O, [online] URL: <http://www.amendia.com/zeuso.html> [retrieved on Jan. 27, 2013].

* cited by examiner

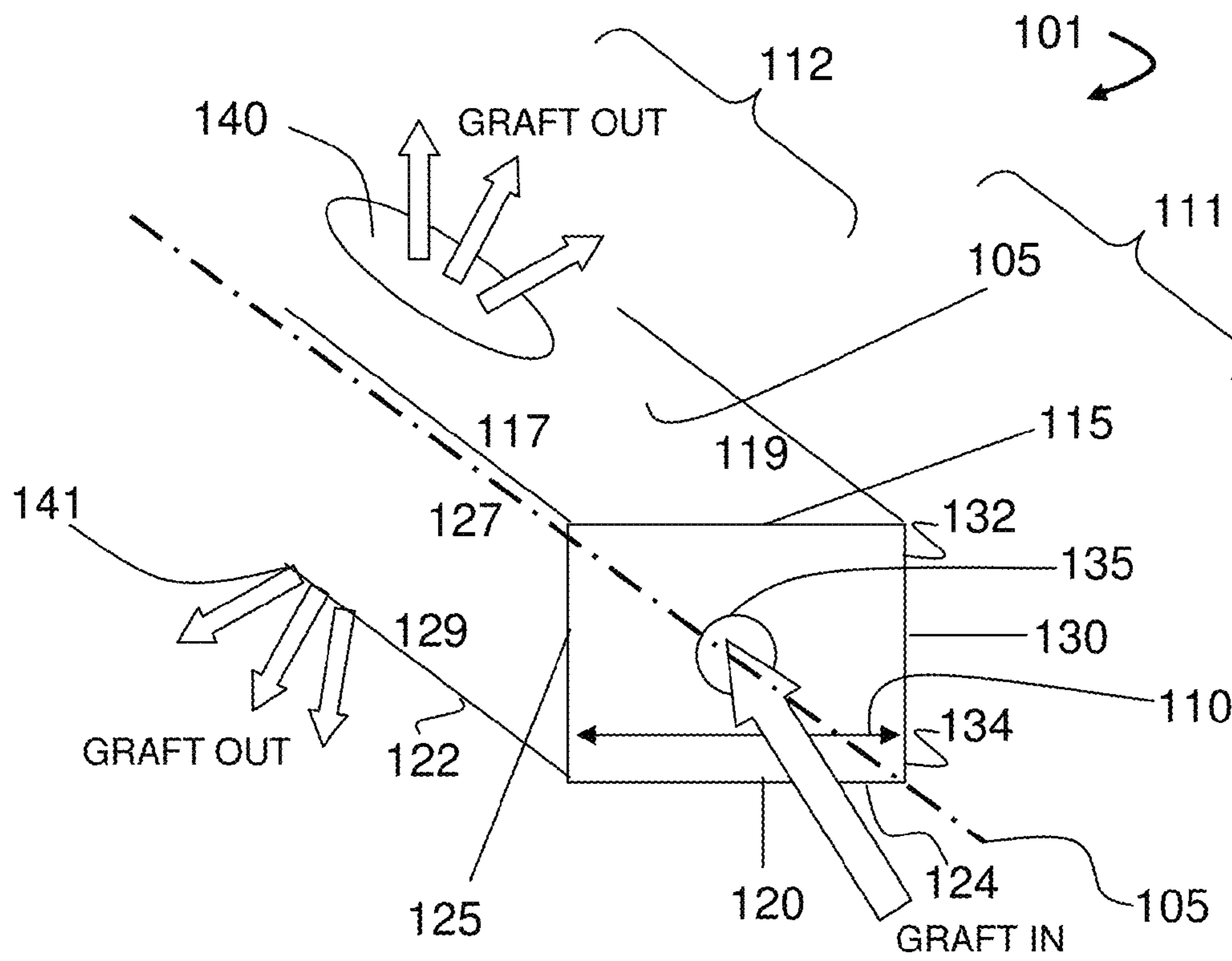

FIG. 1A

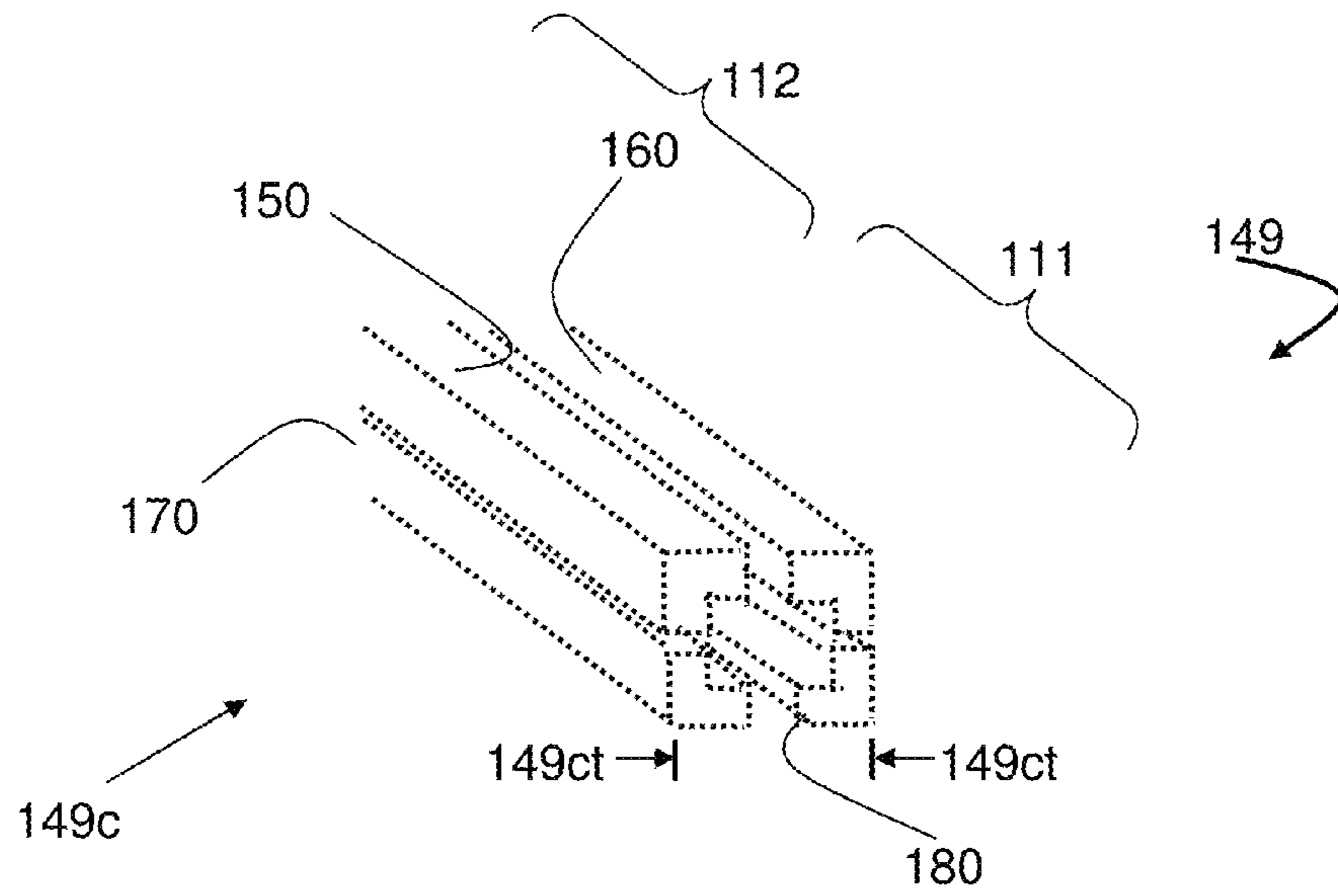

FIG. 1B

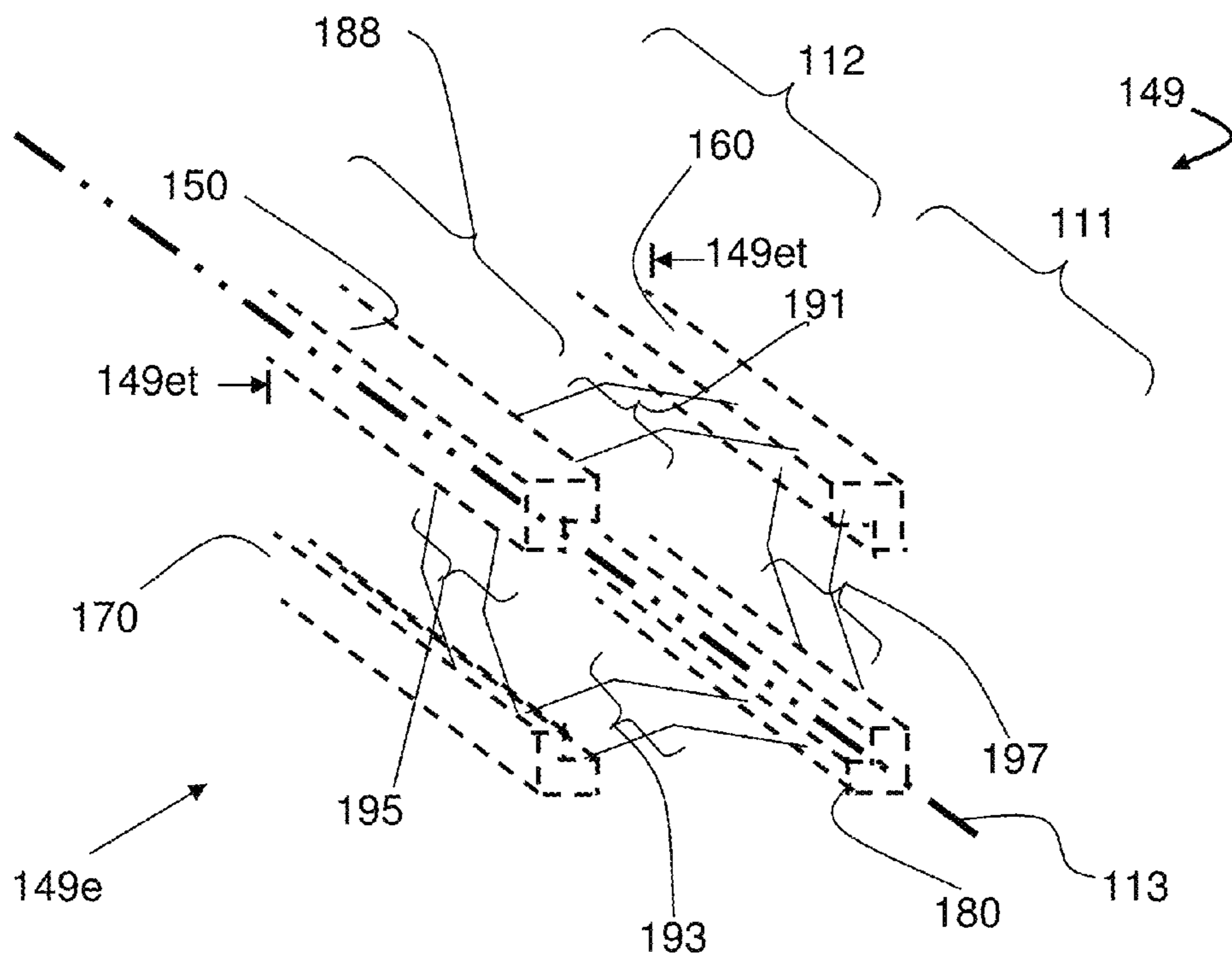

FIG. 1C

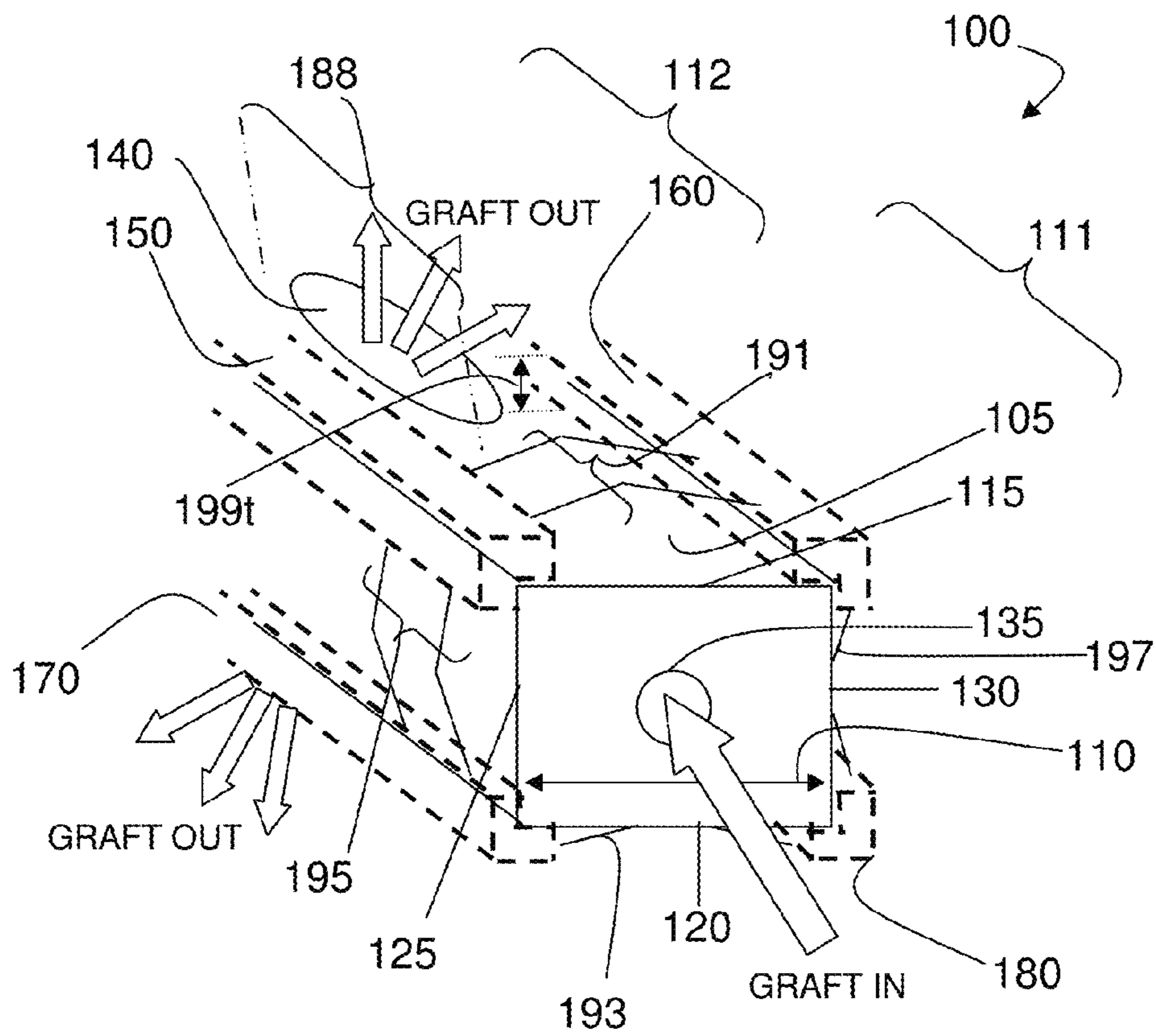

FIG. 1D

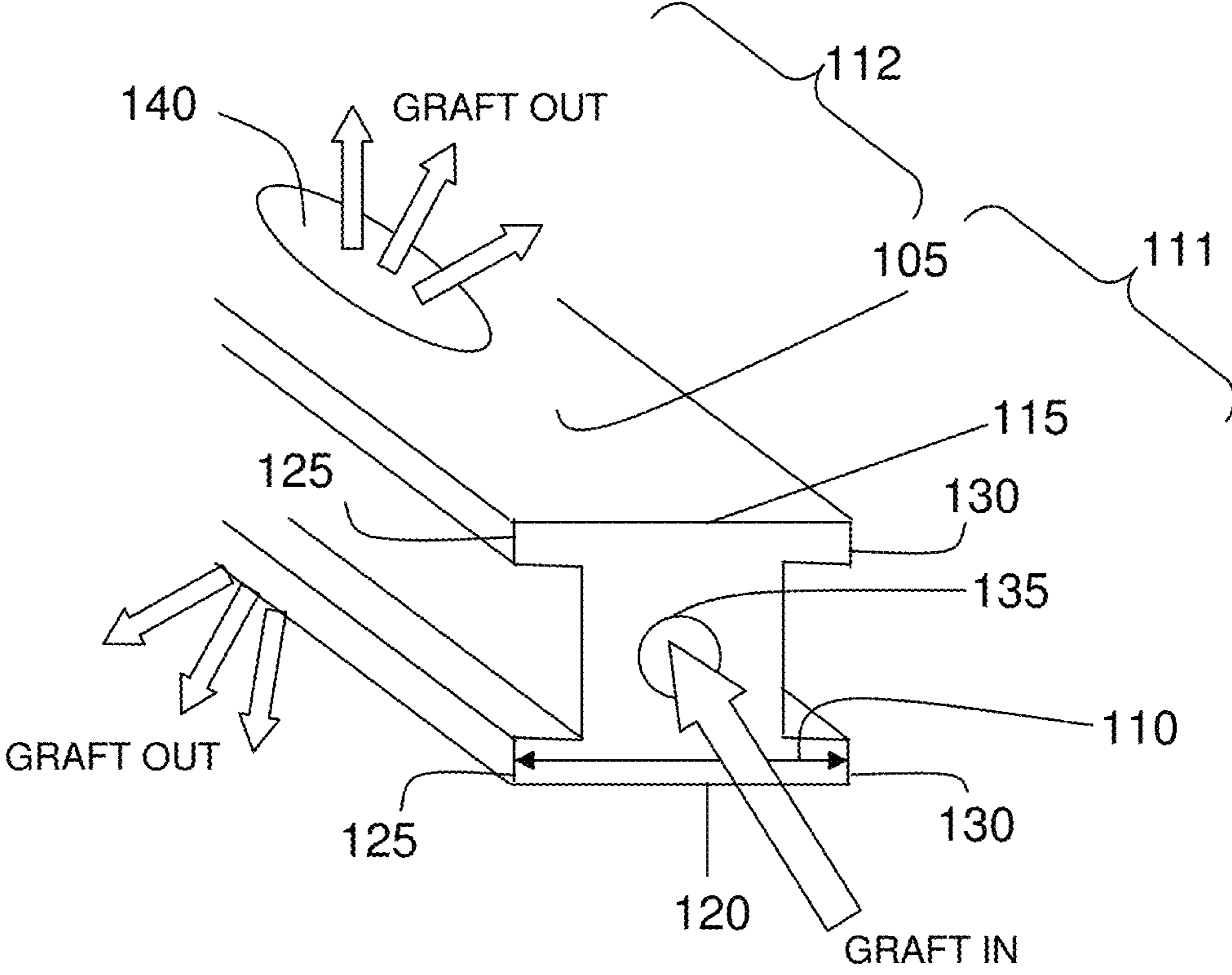

FIG. 1E

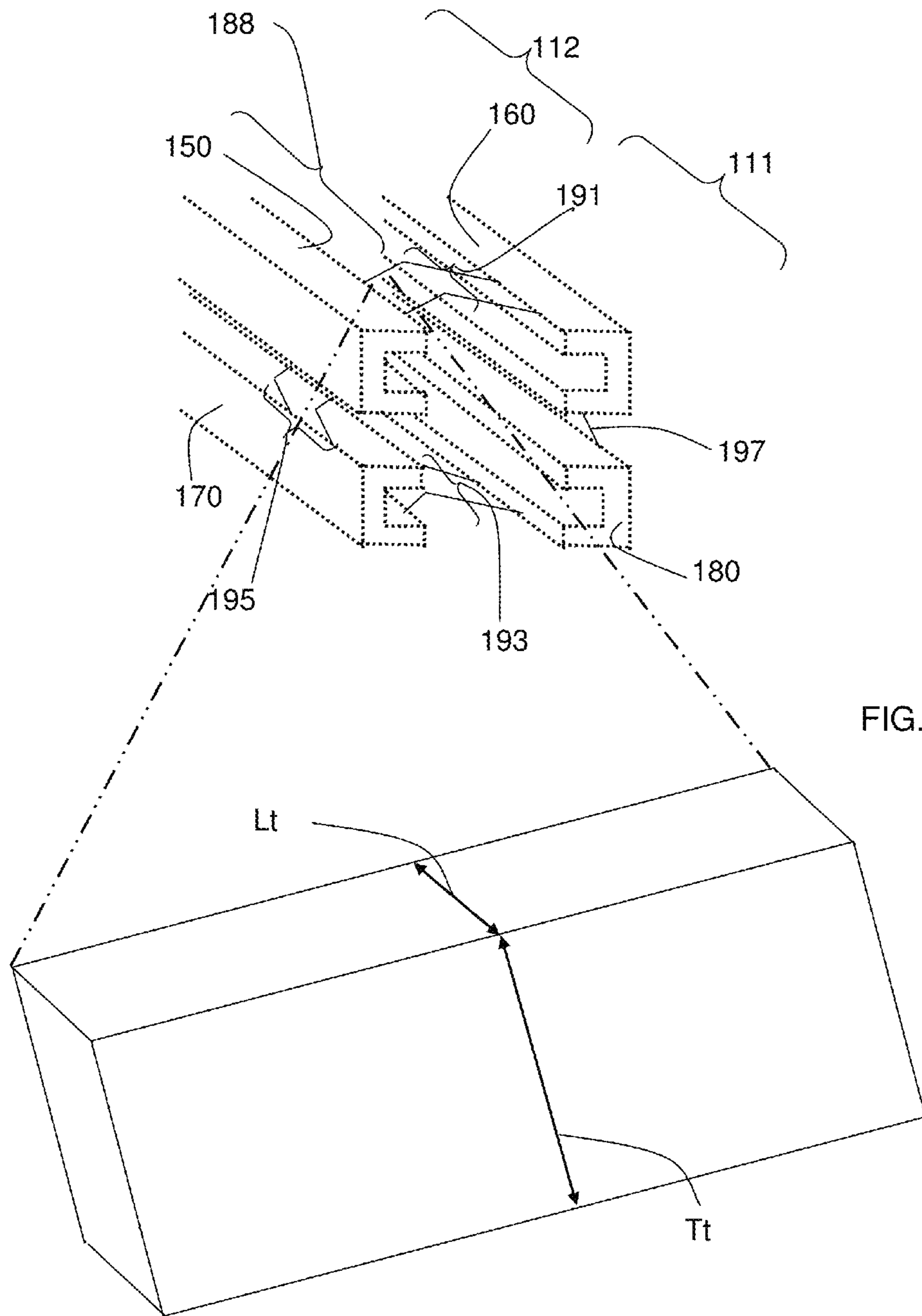
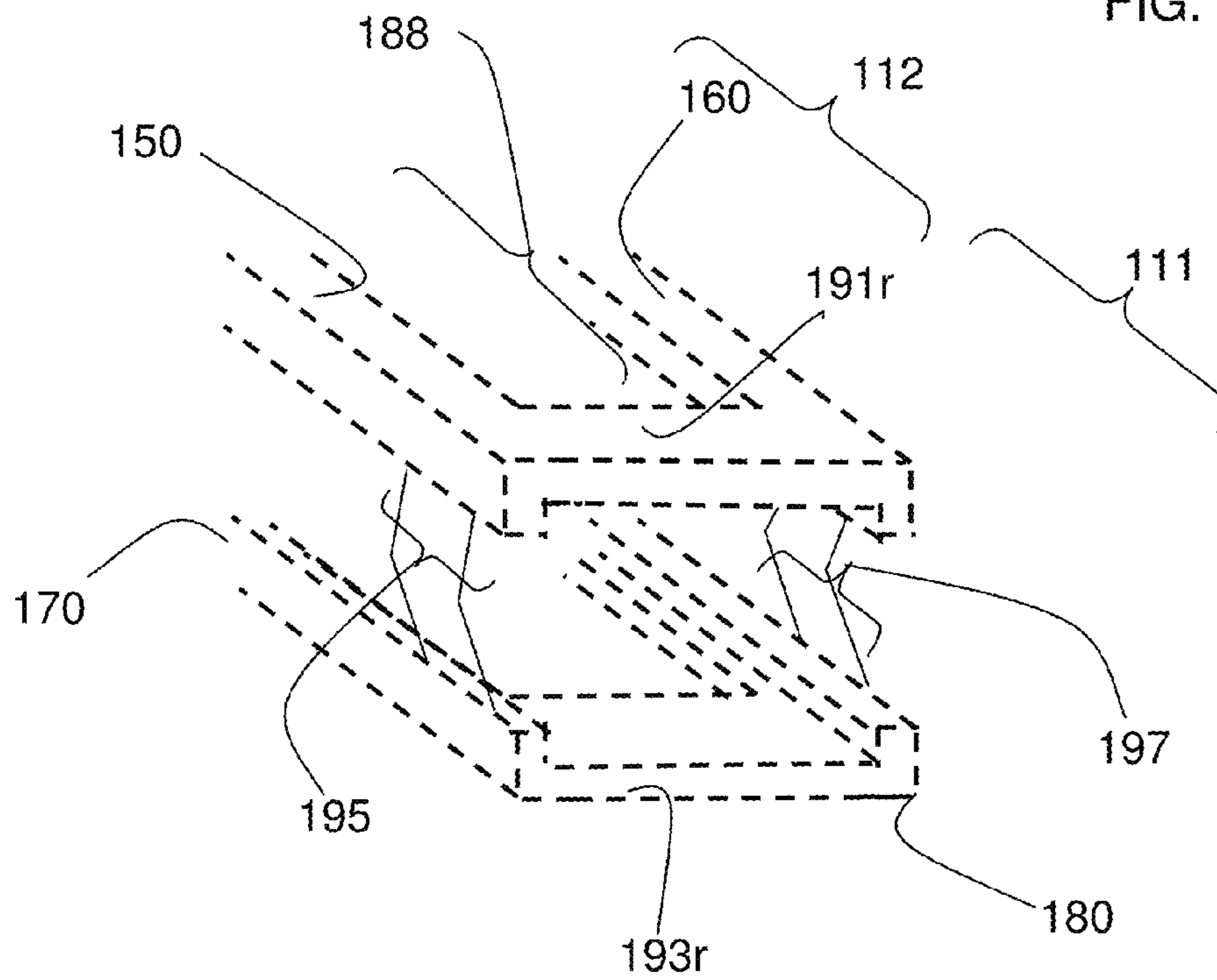
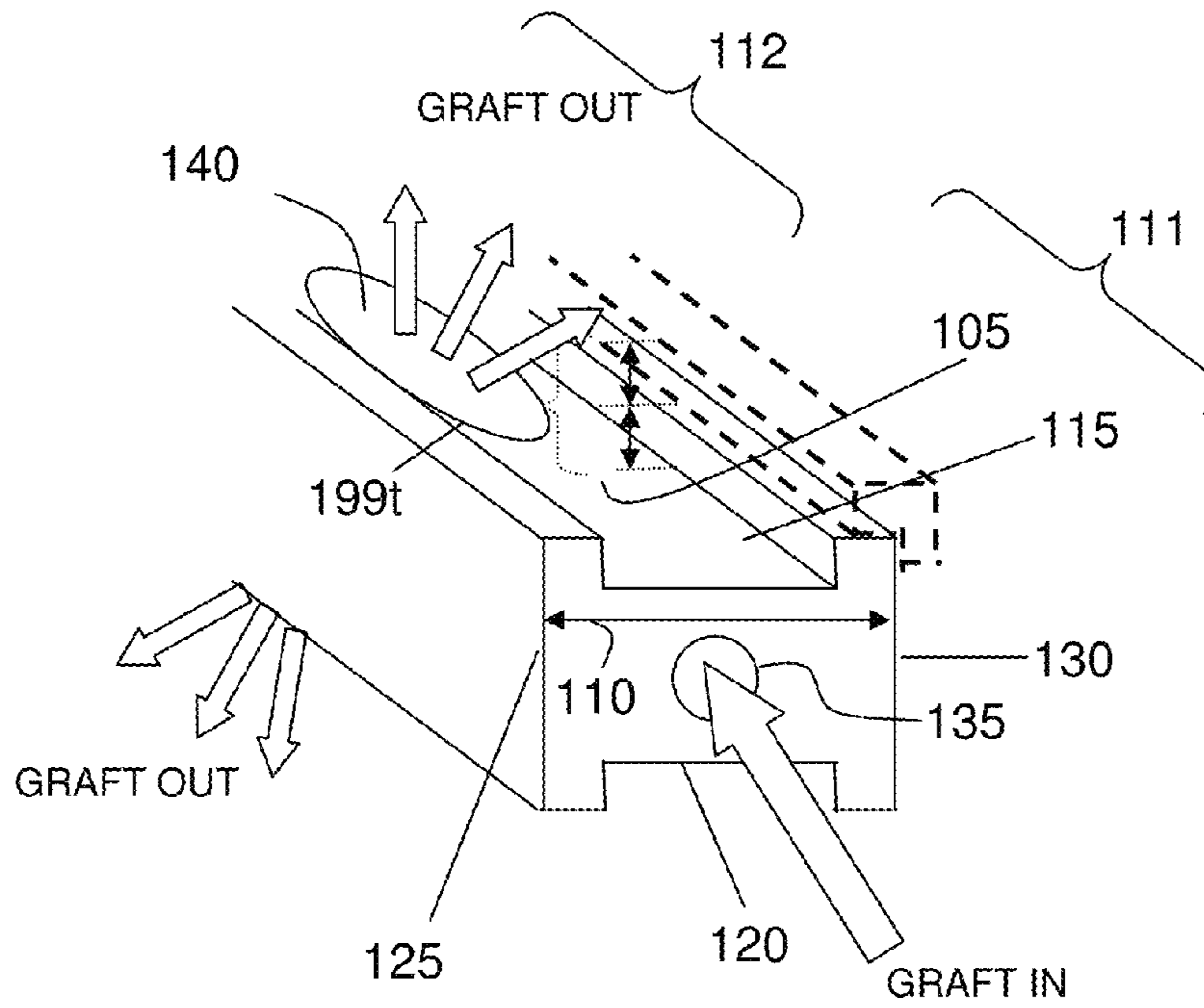

FIG. 1F

FIG. 1G



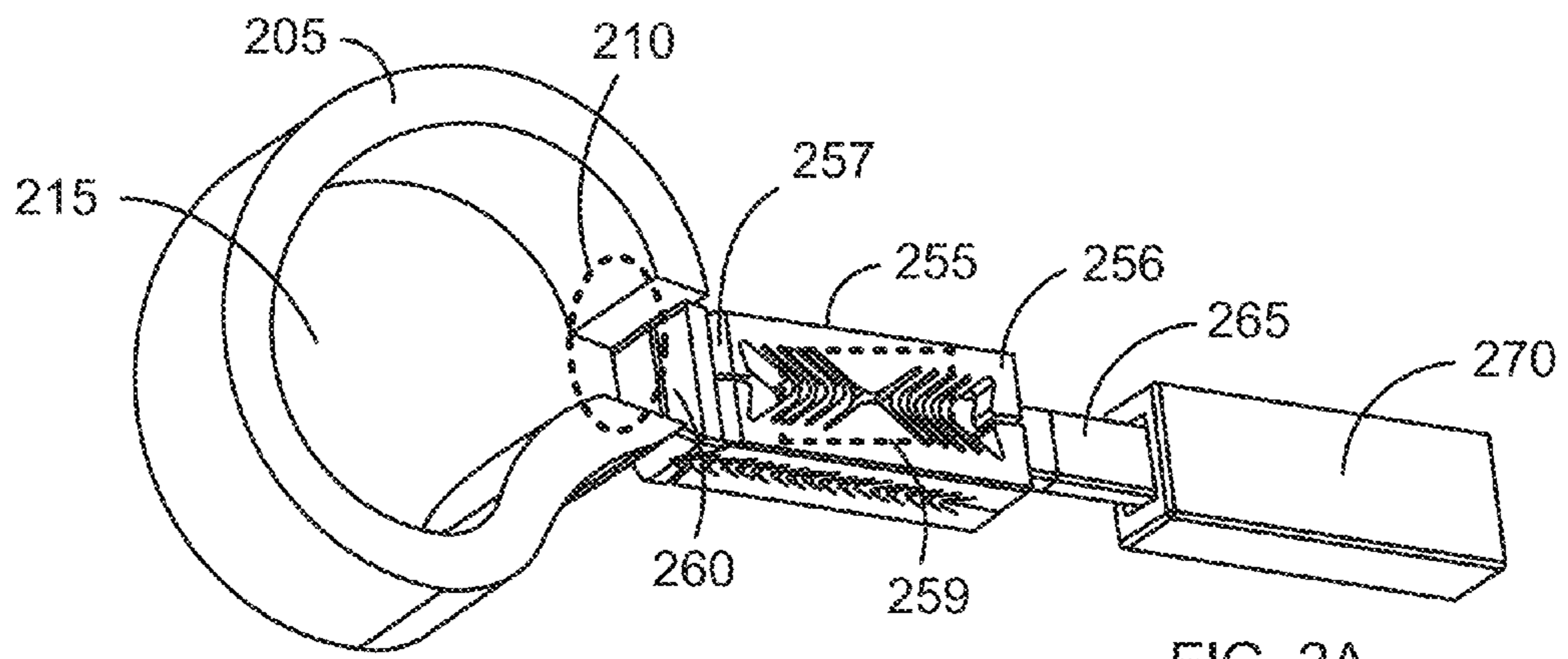

FIG. 2A

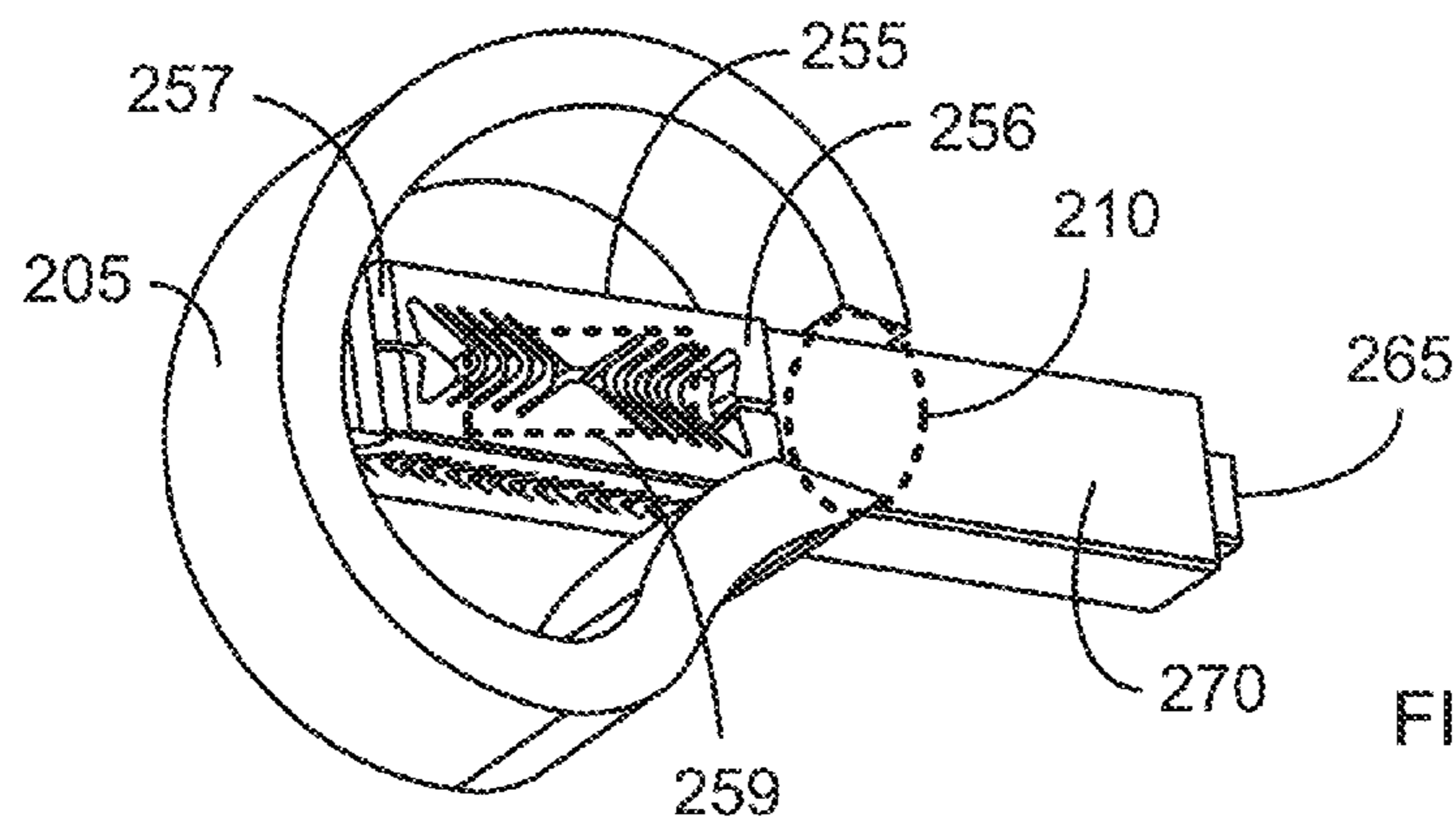

FIG. 2B

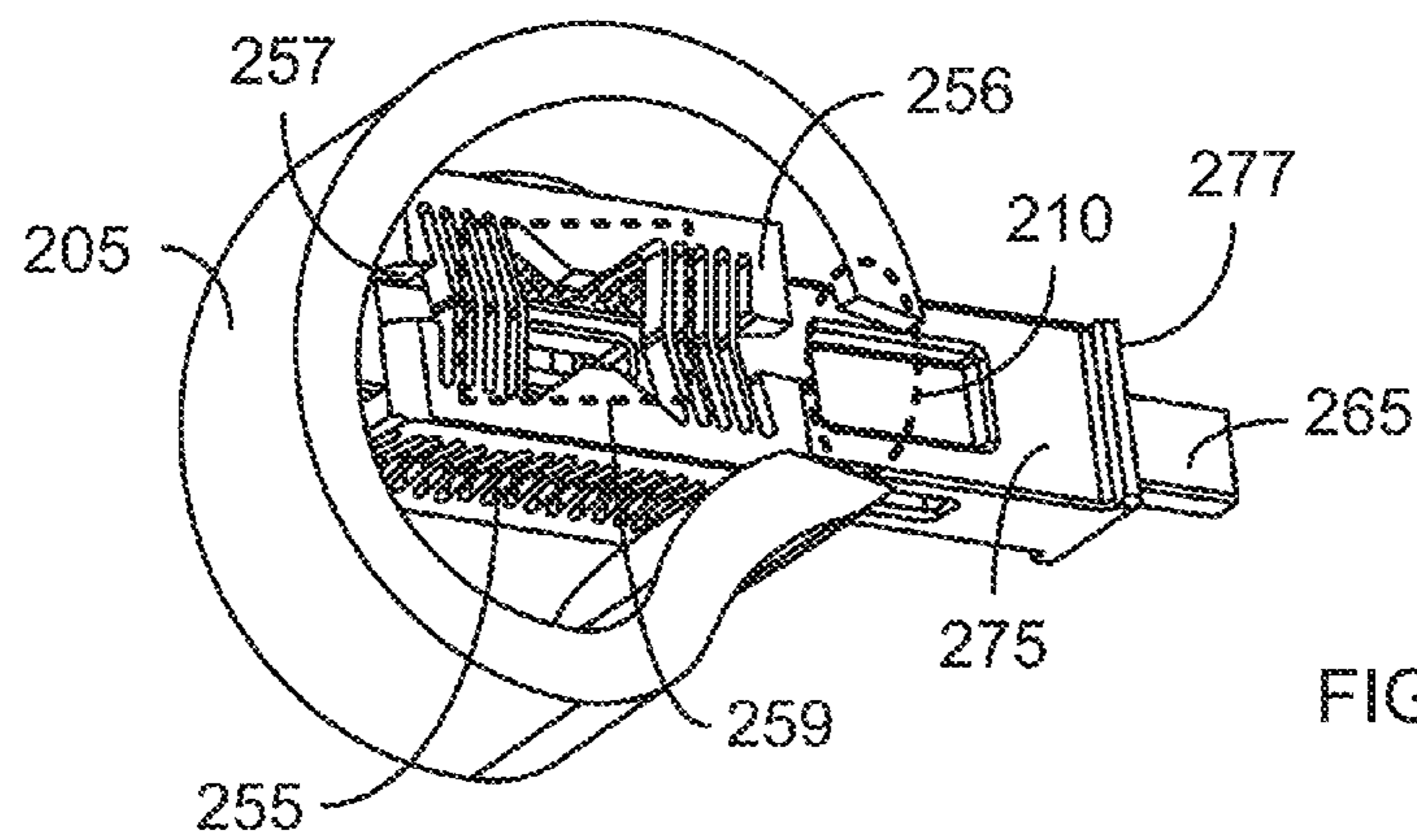
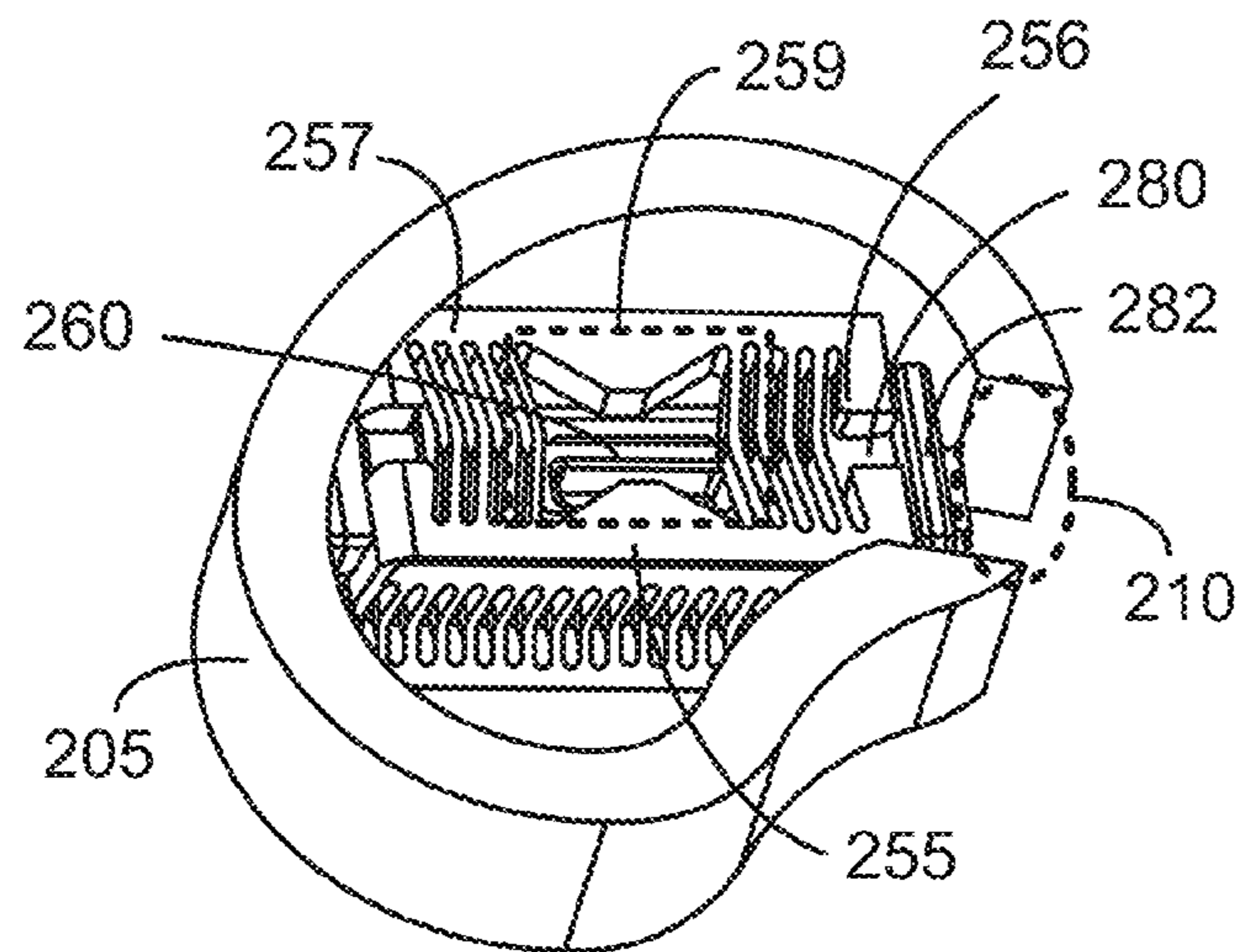
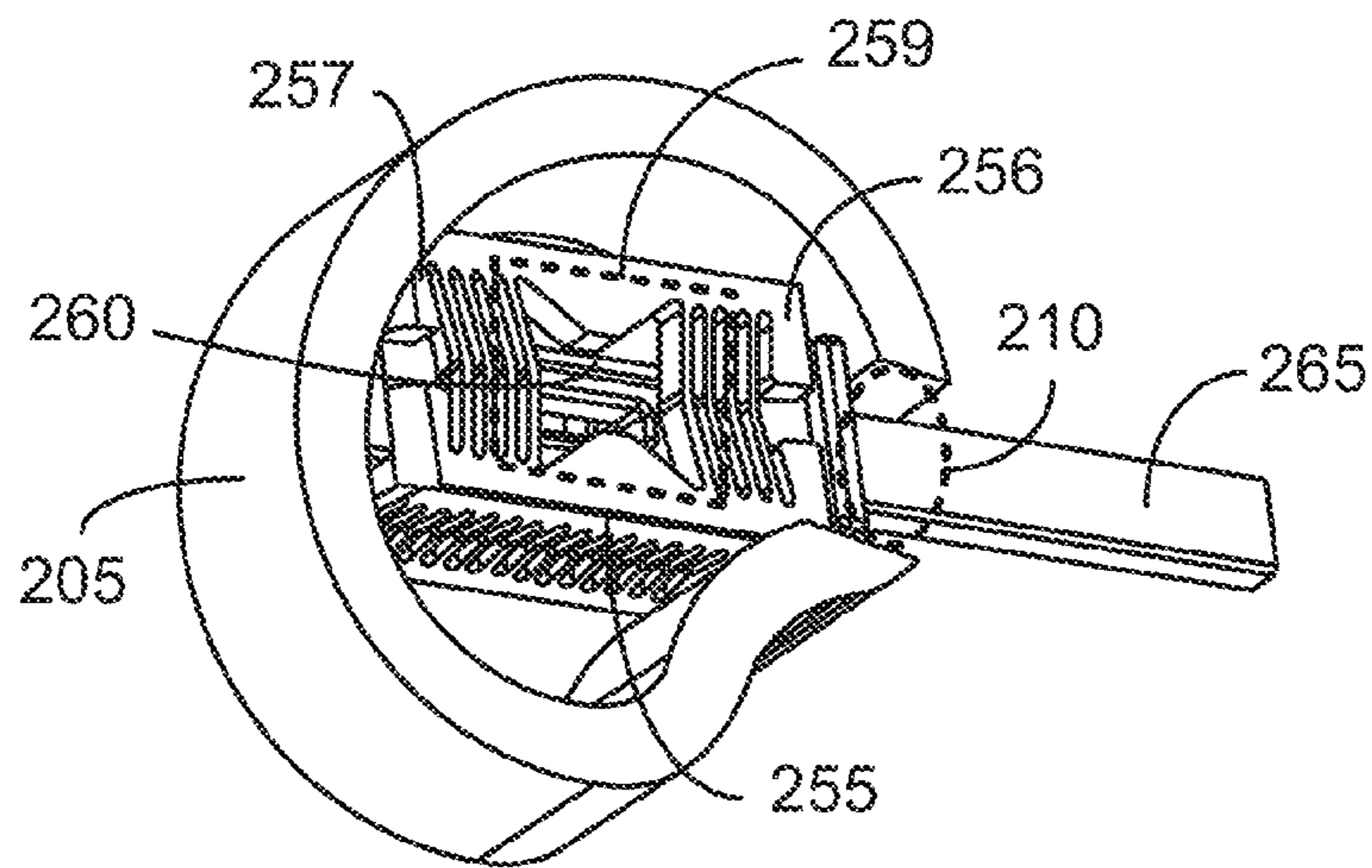
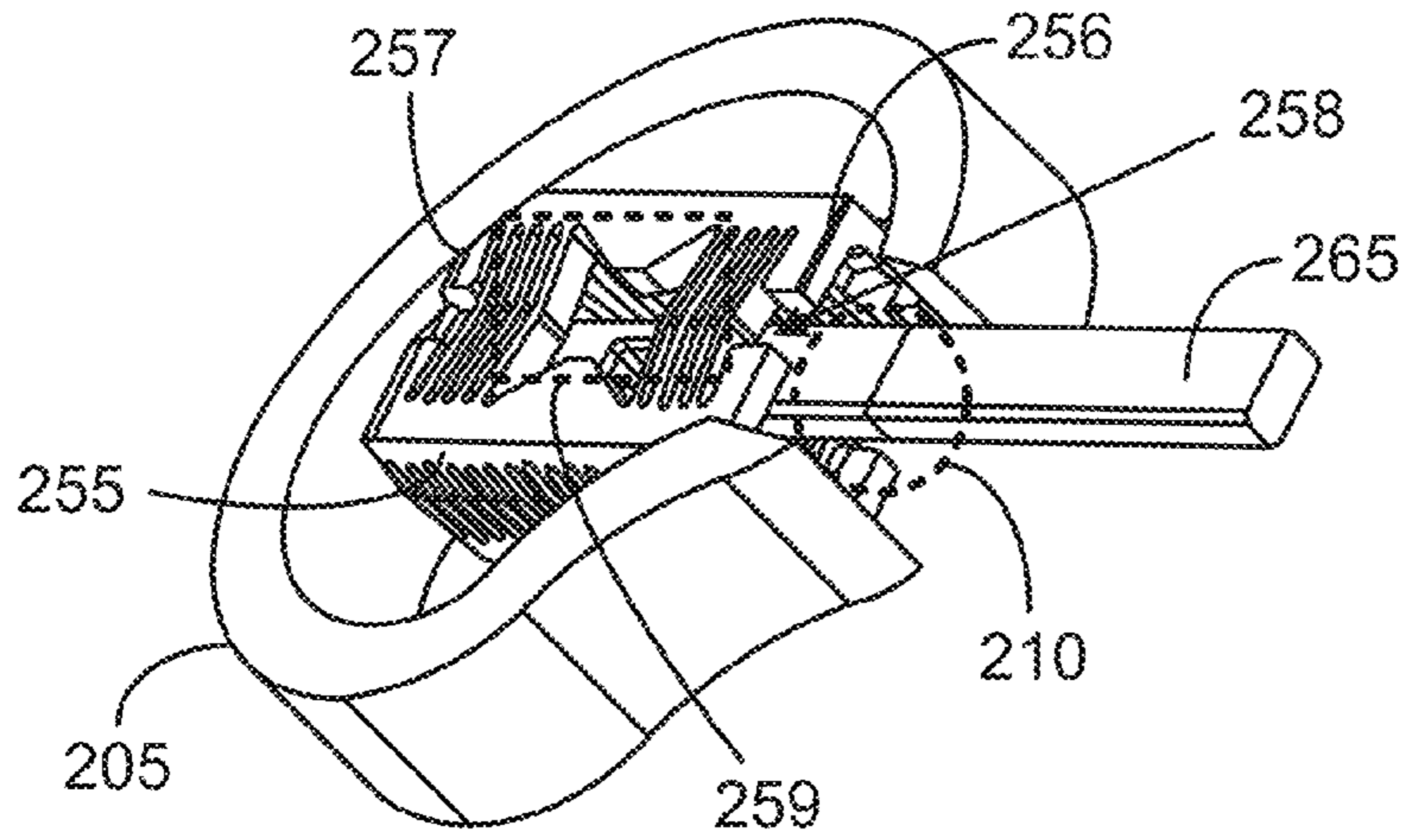

FIG. 2C



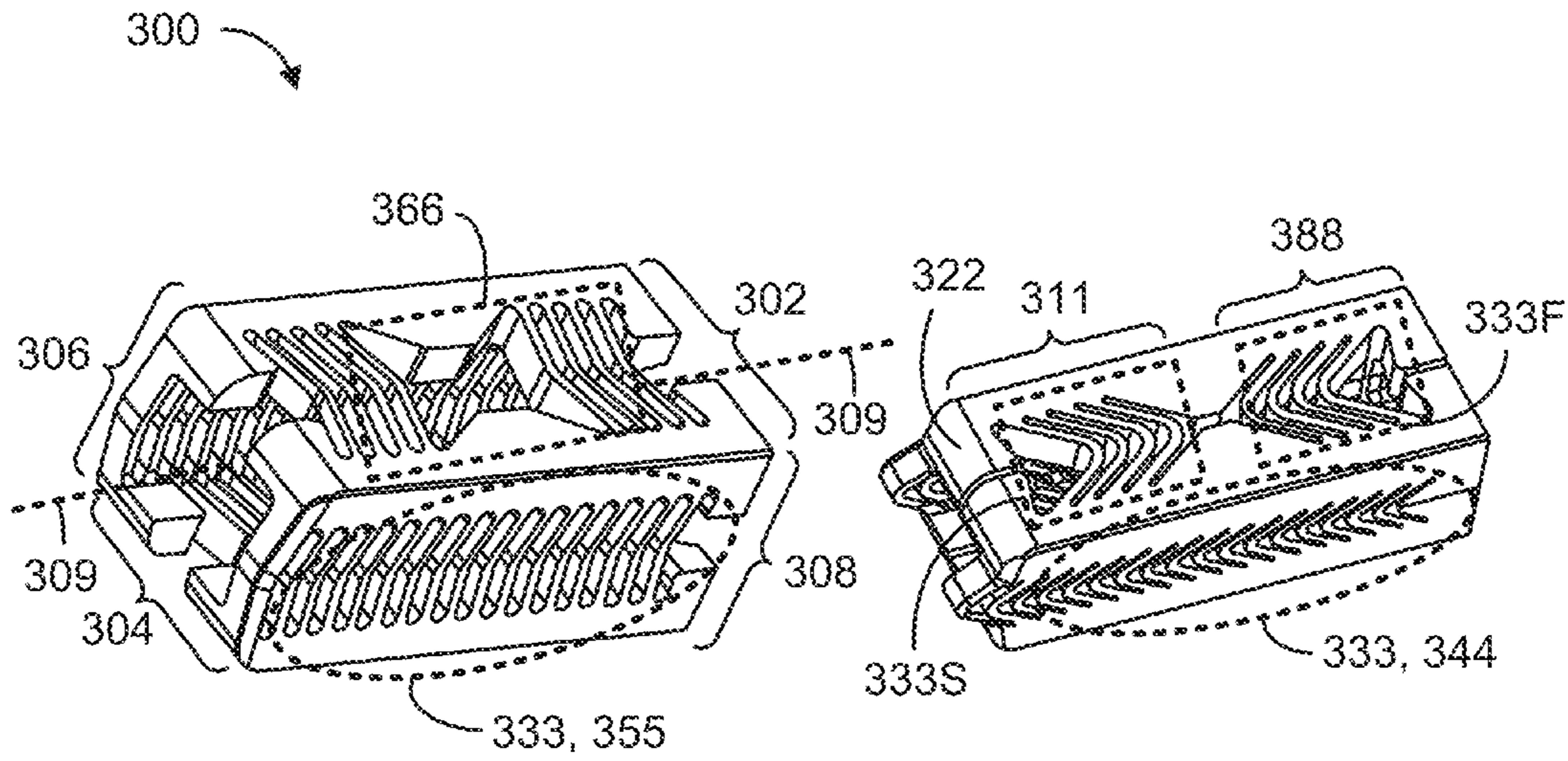

FIG. 3A

FIG. 3B

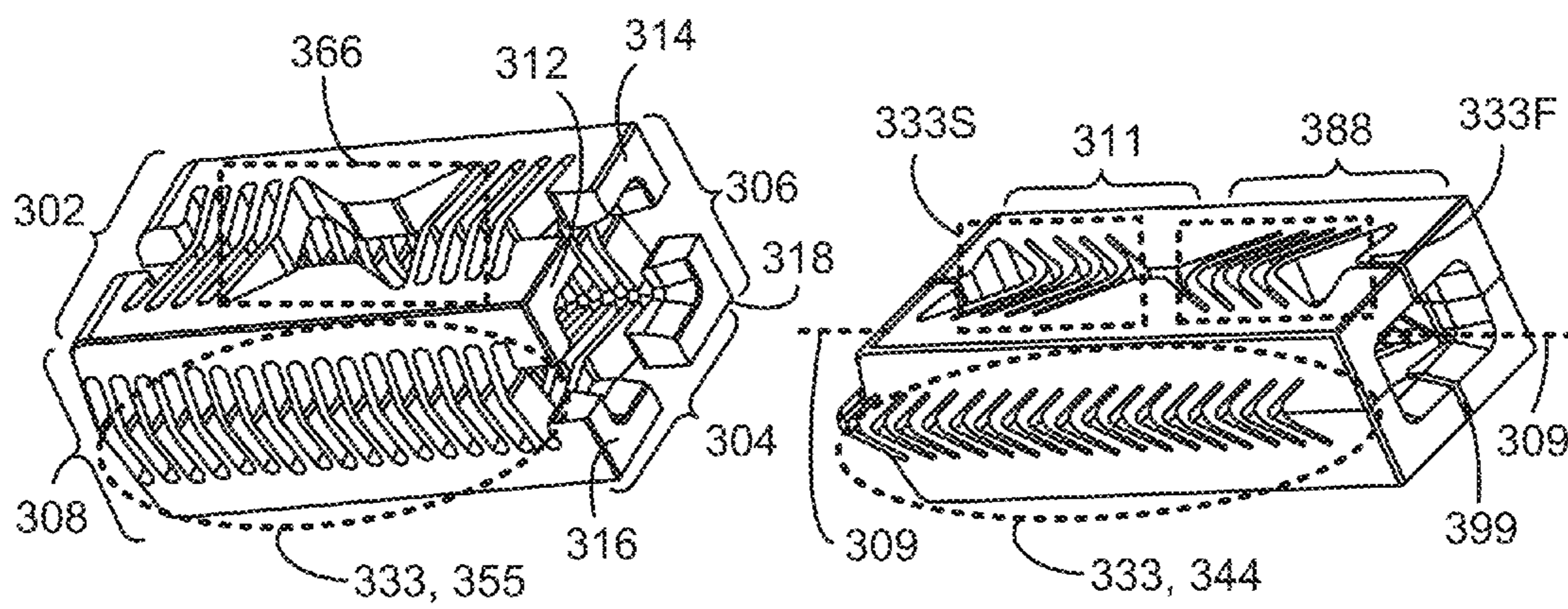
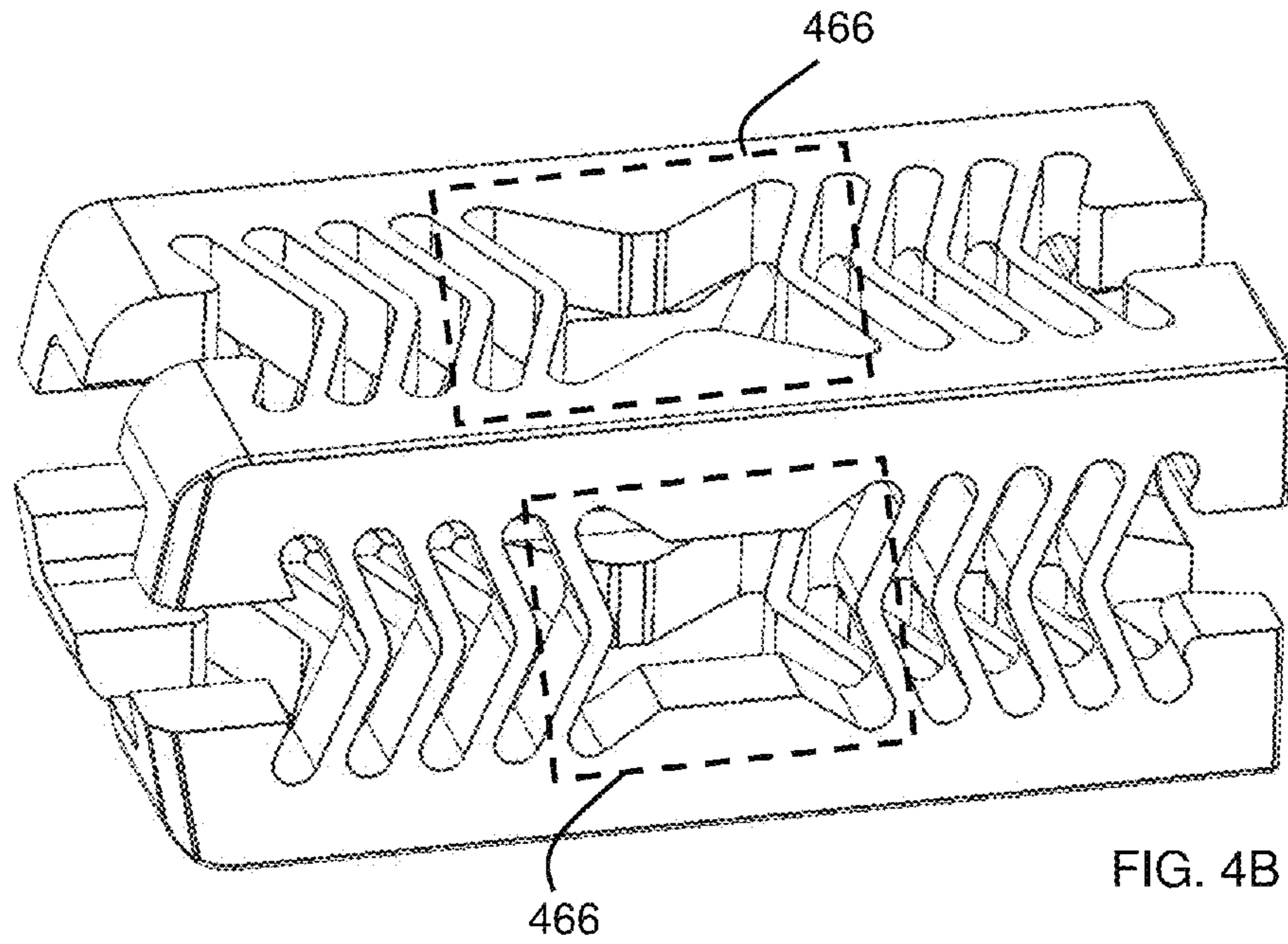
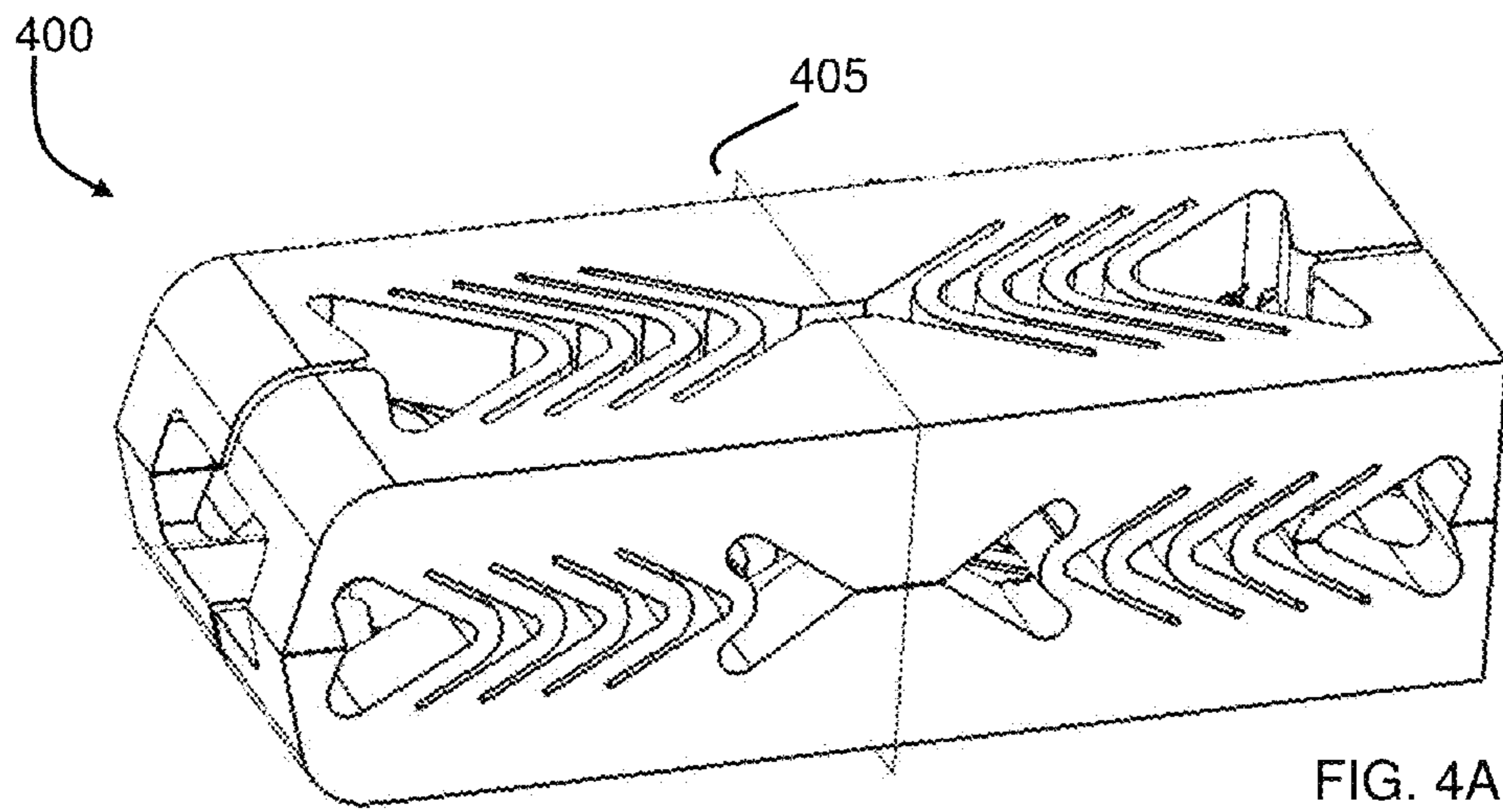
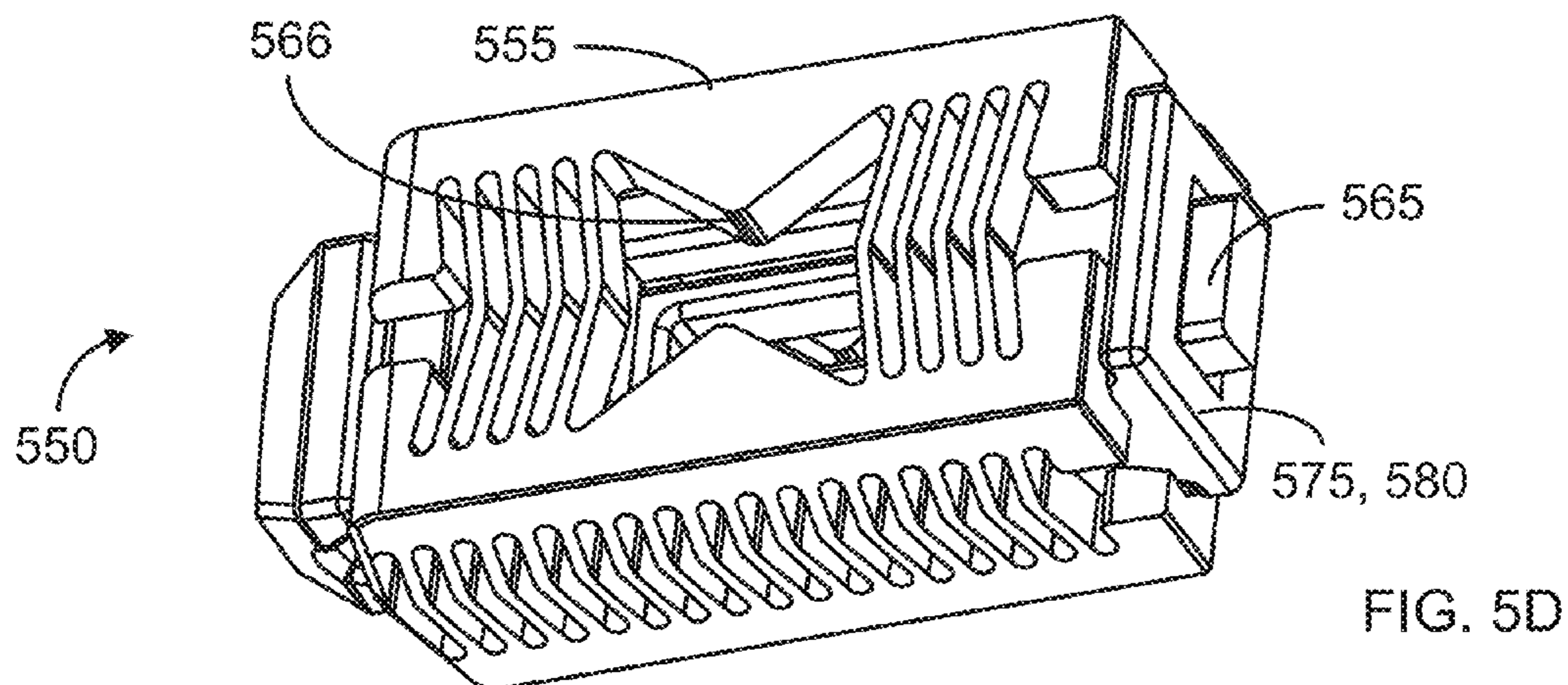
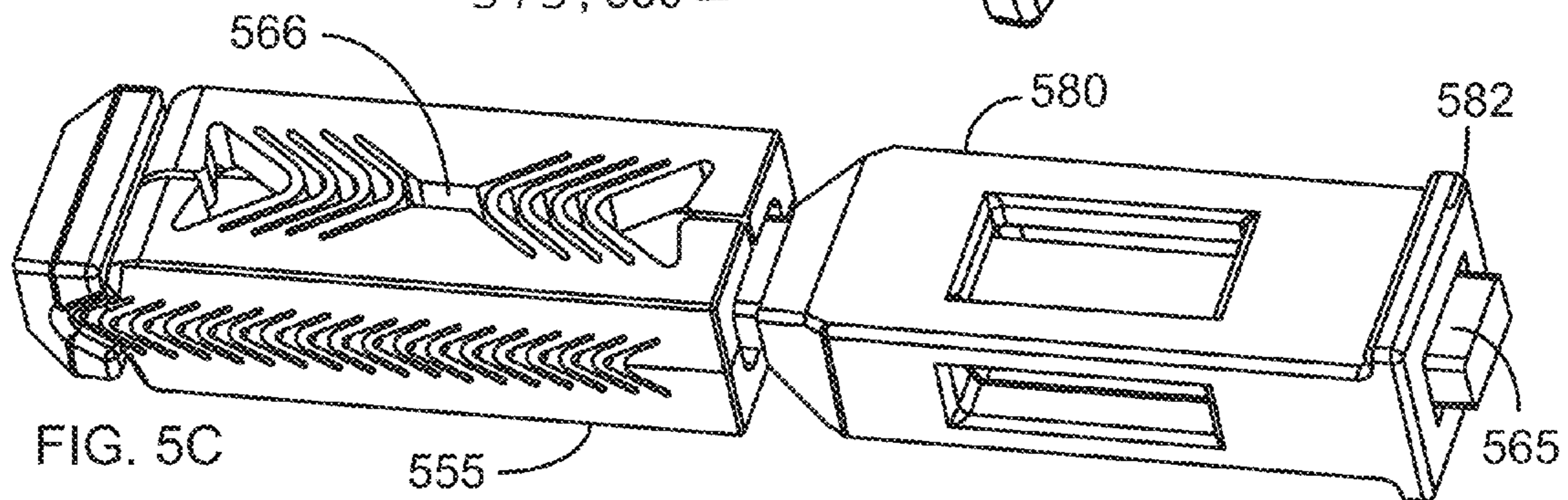
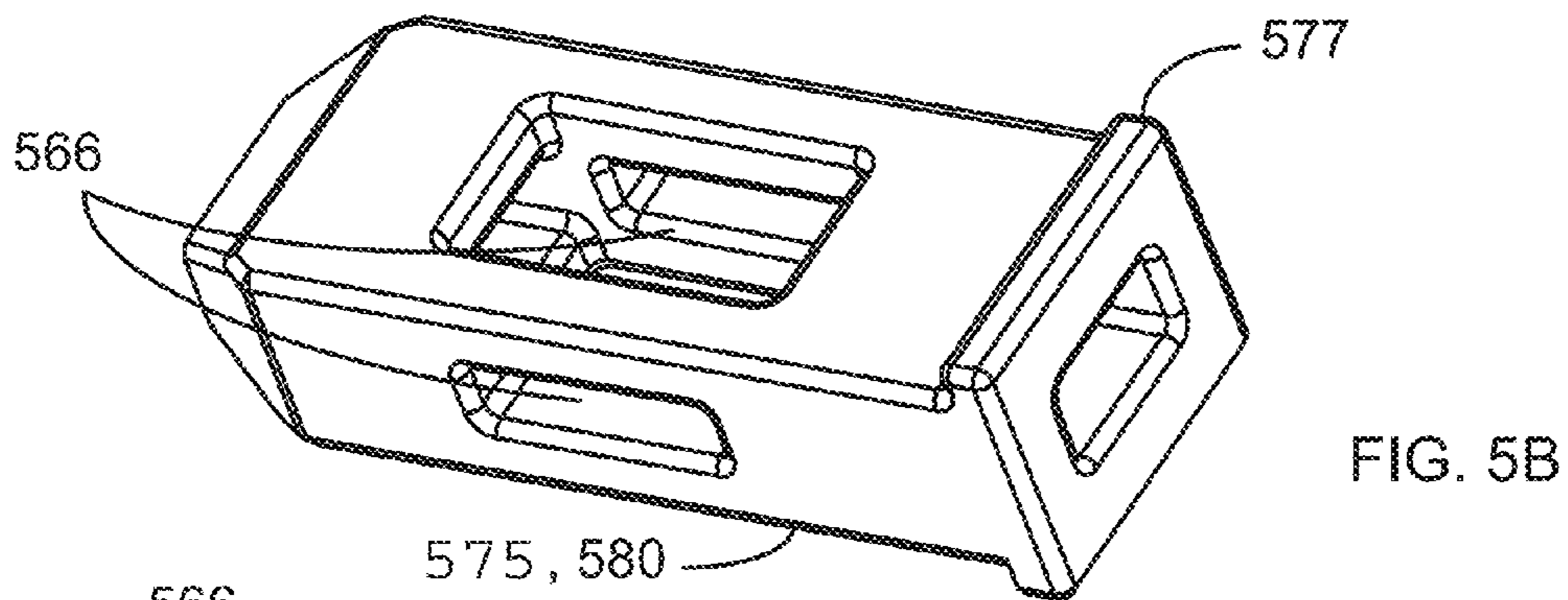
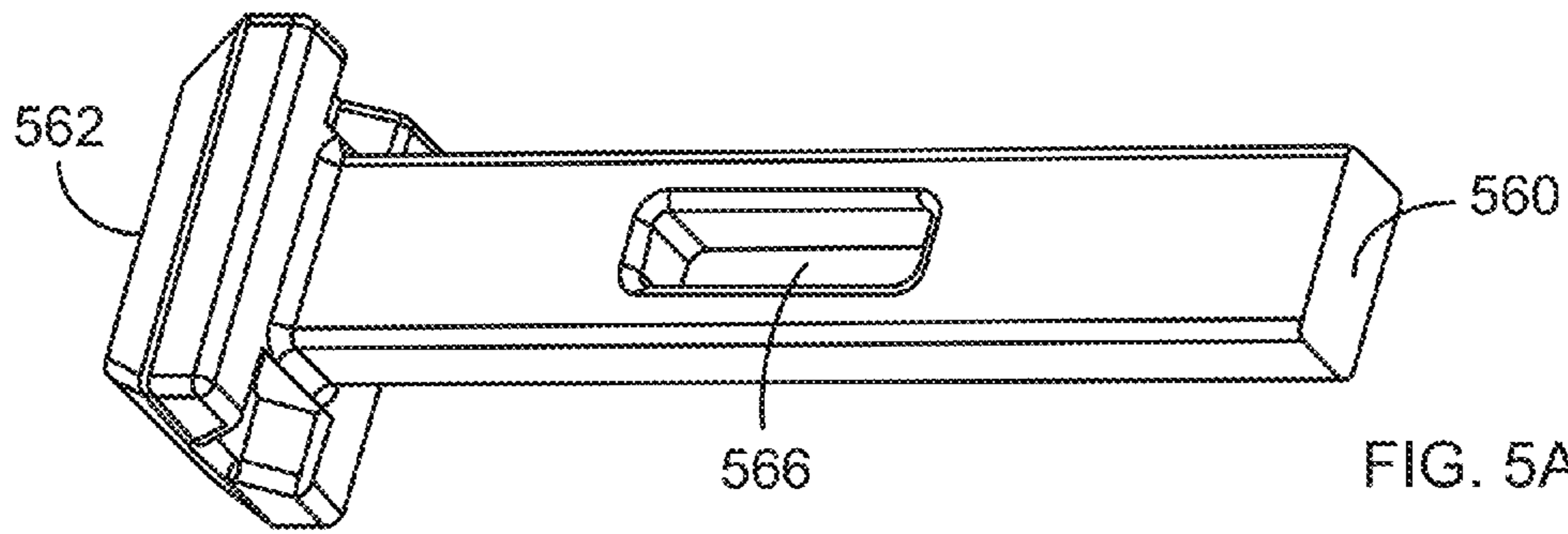

FIG. 3C

FIG. 3D





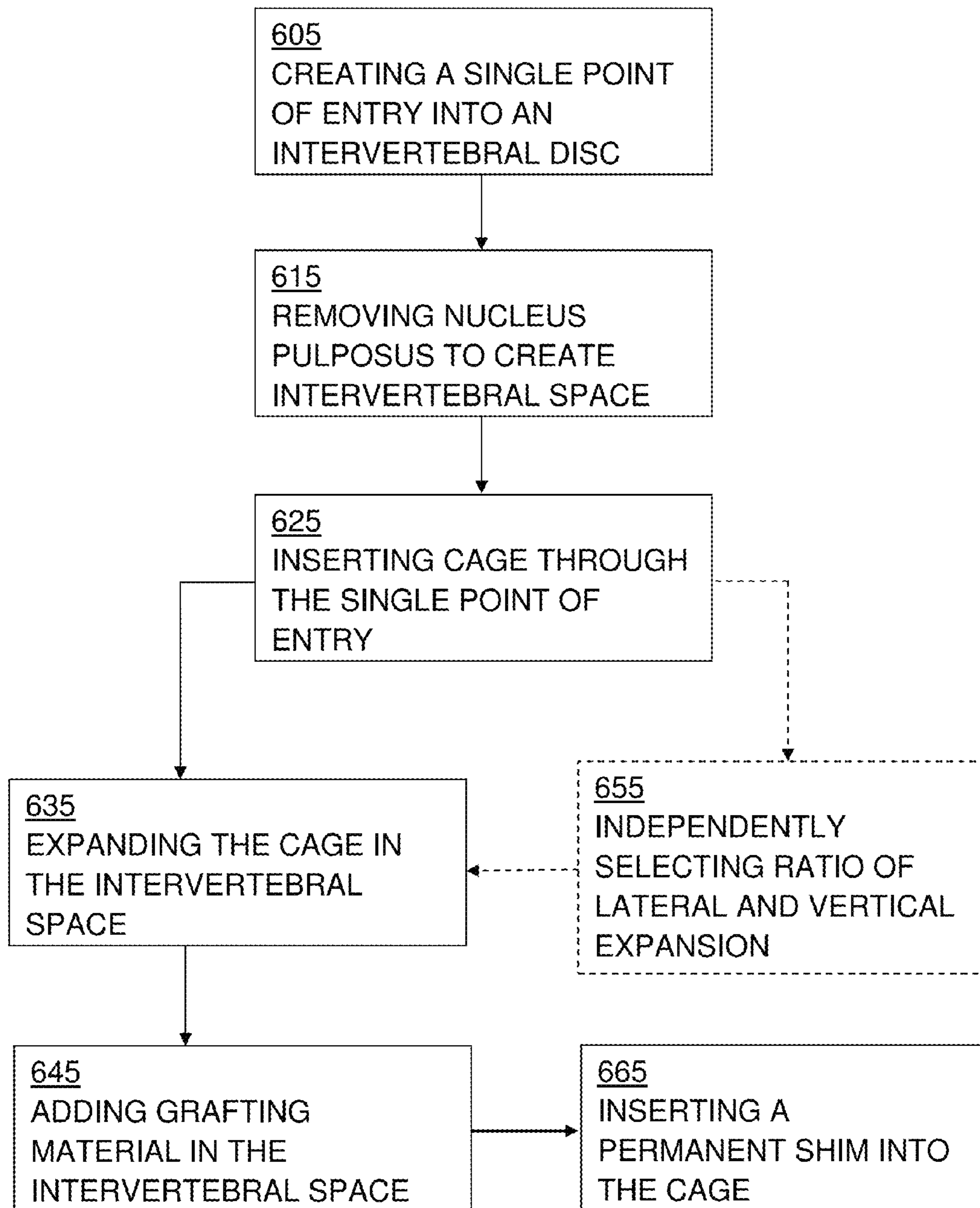

FIG. 6

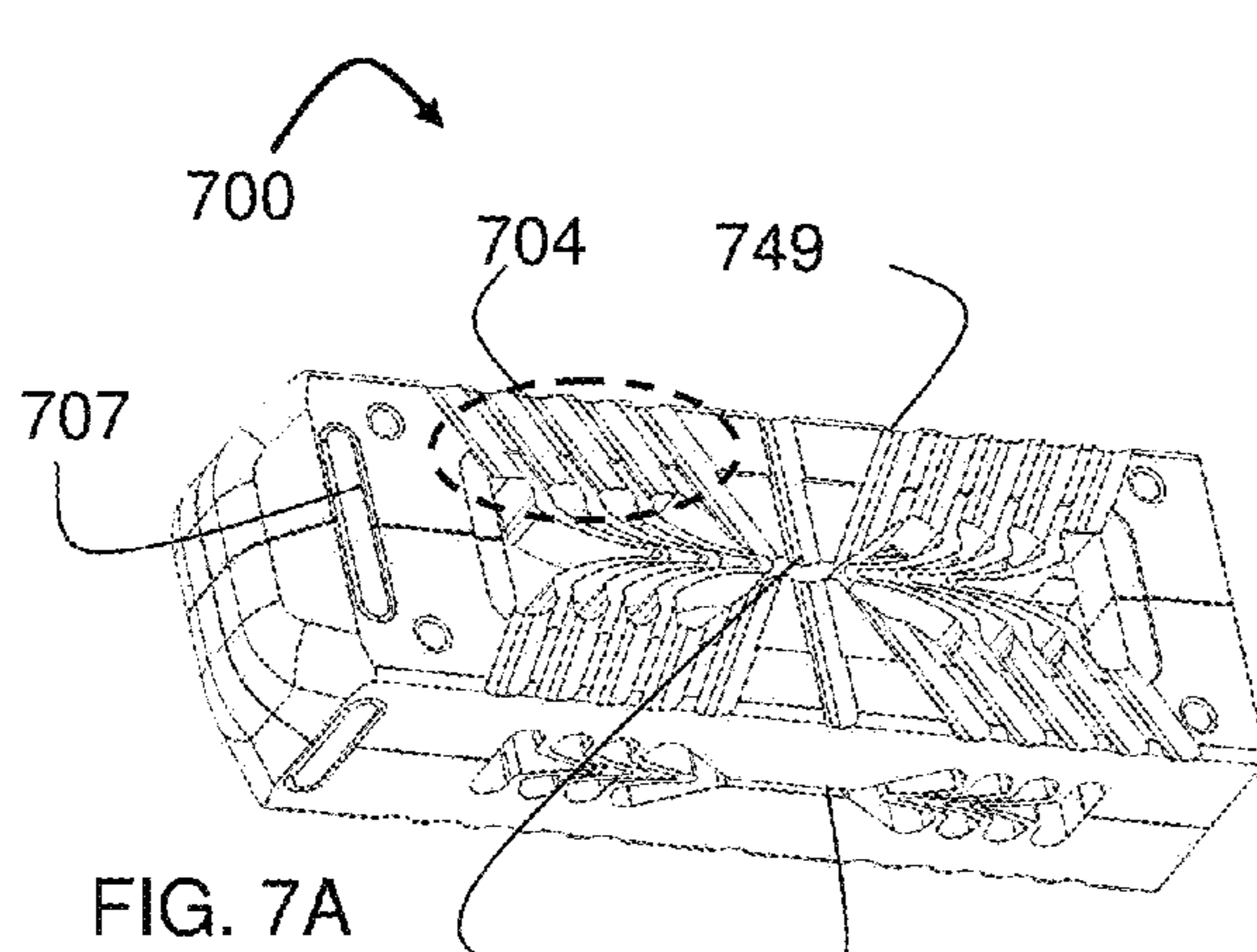

FIG. 7A

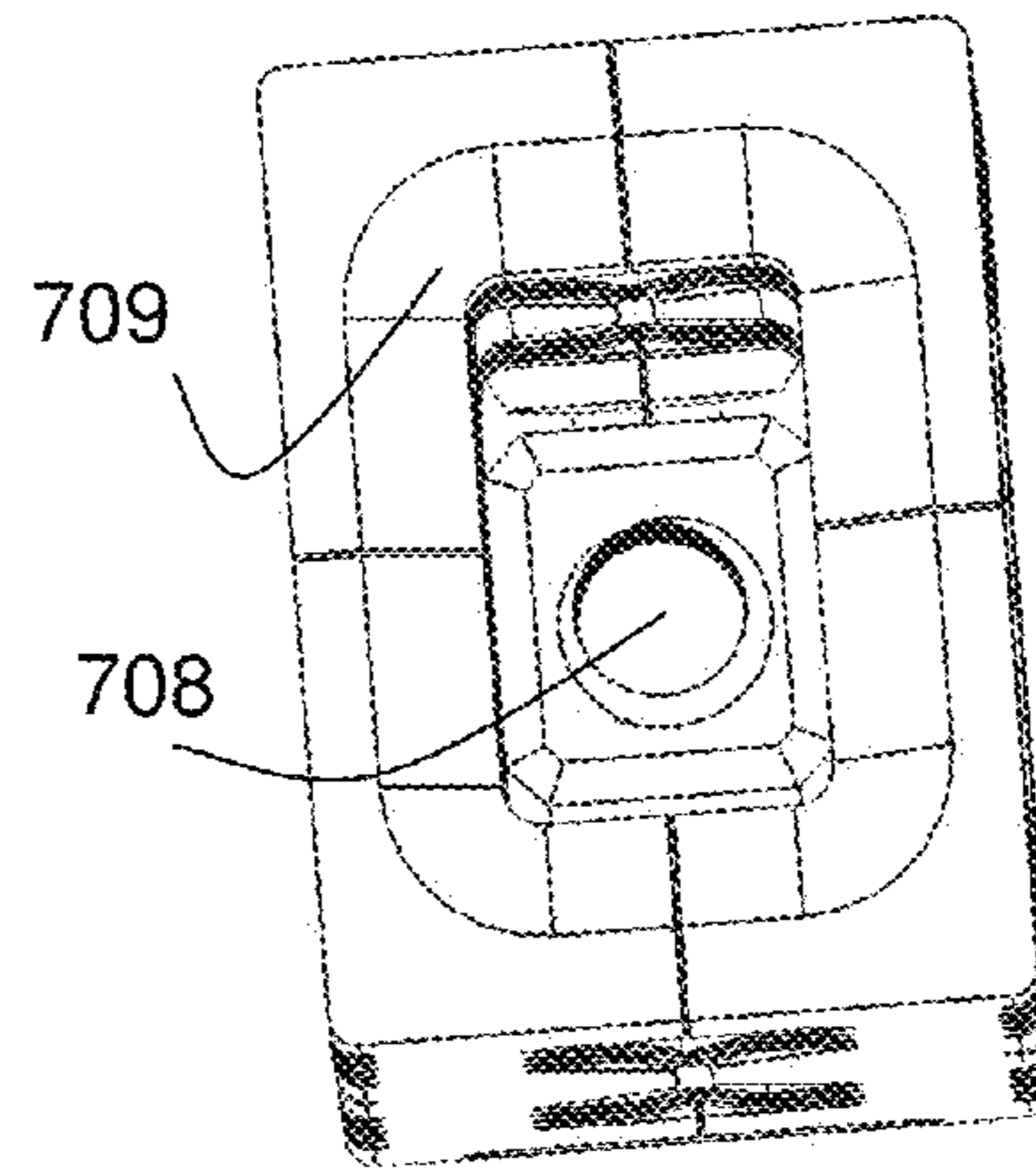

FIG. 7B

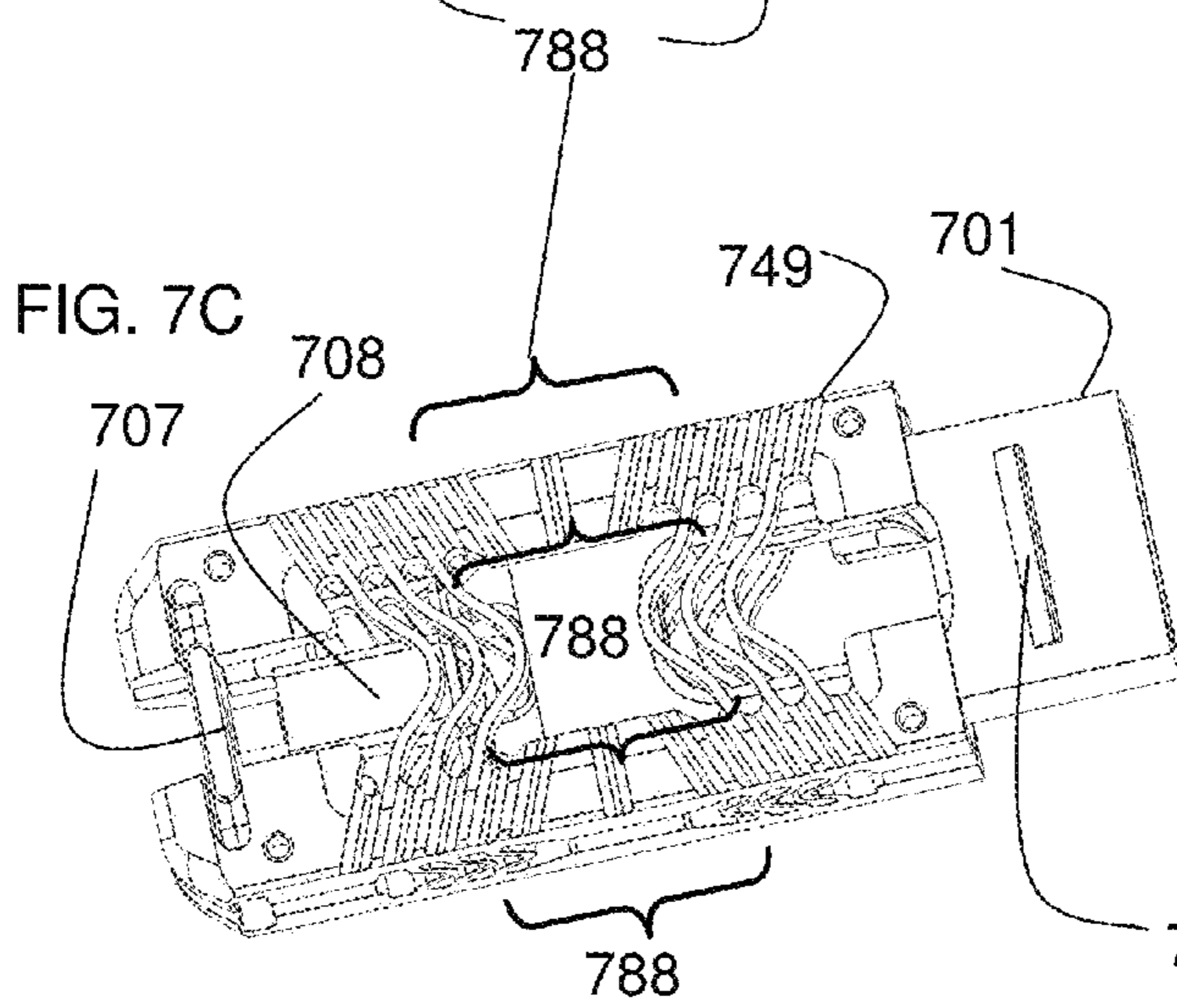

FIG. 7C

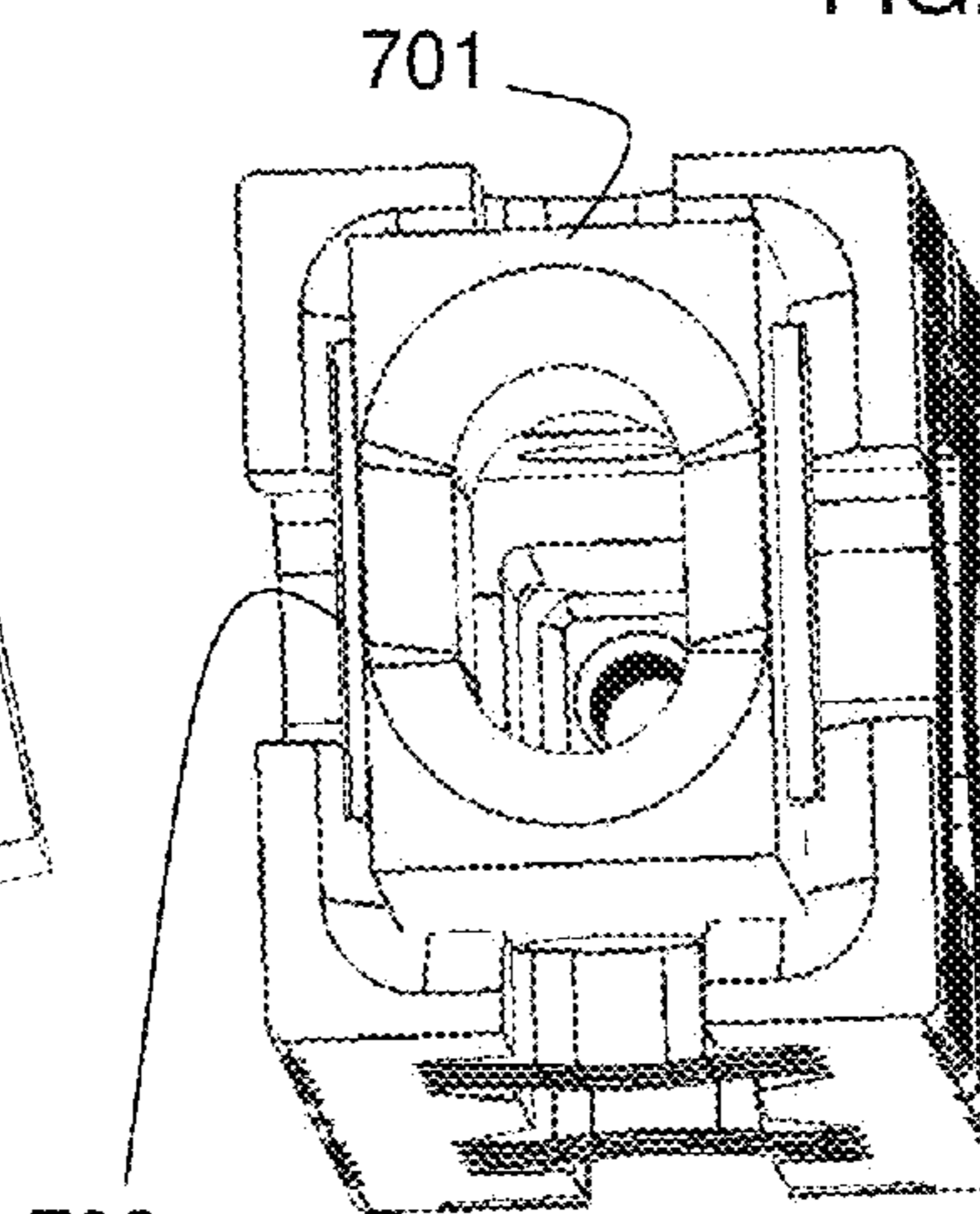

FIG. 7D

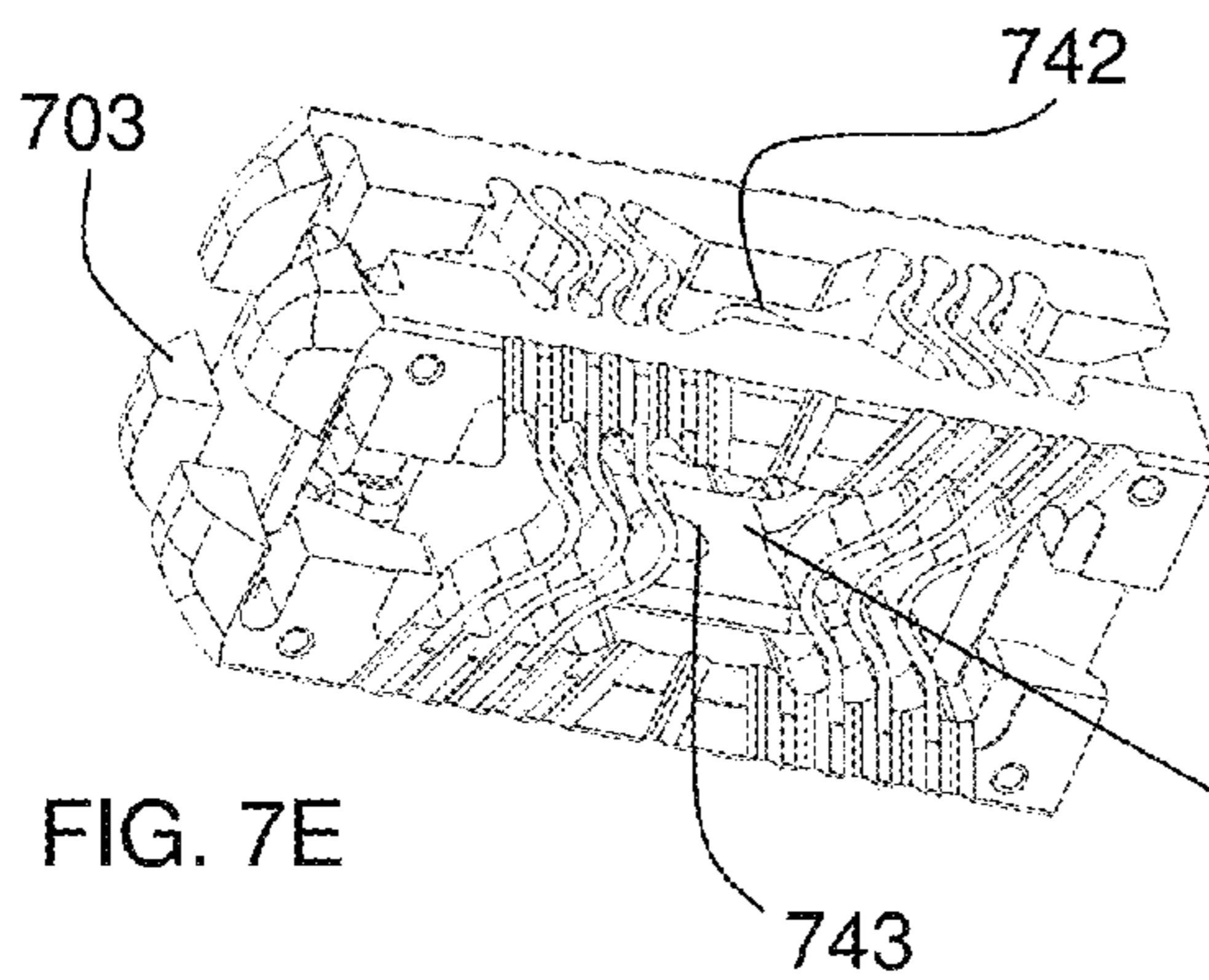

FIG. 7E

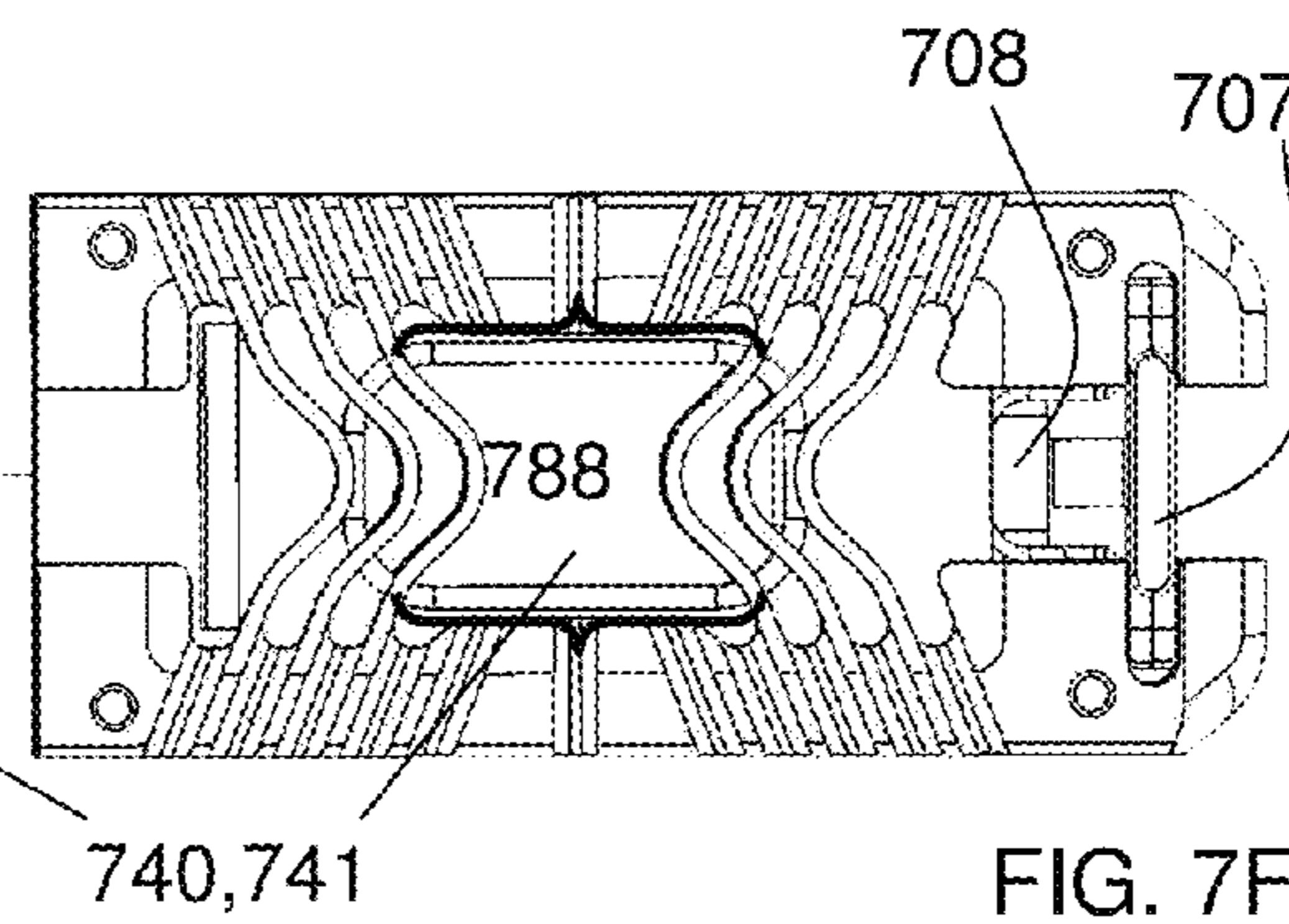

FIG. 7F

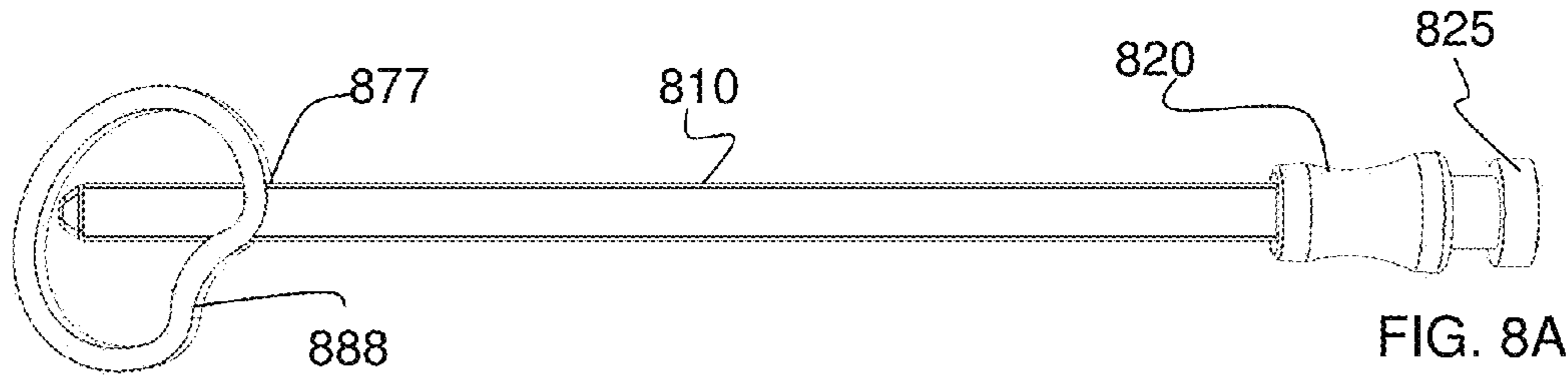

FIG. 8A

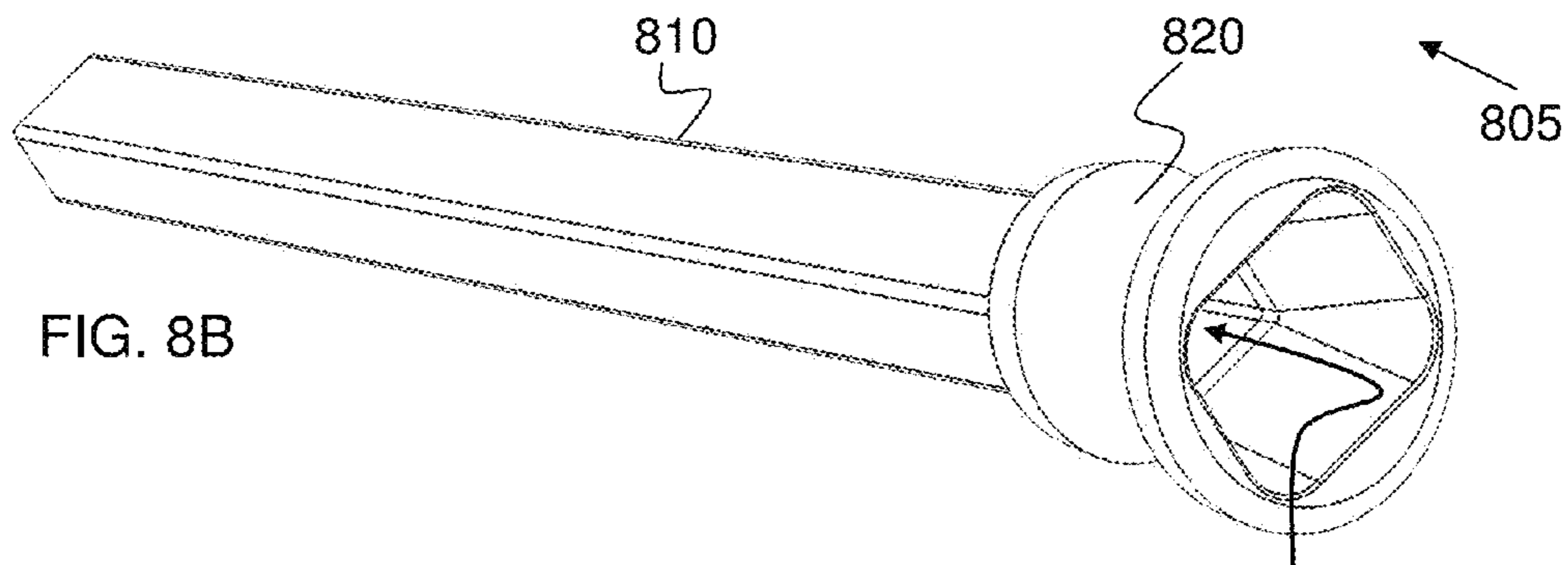

FIG. 8B

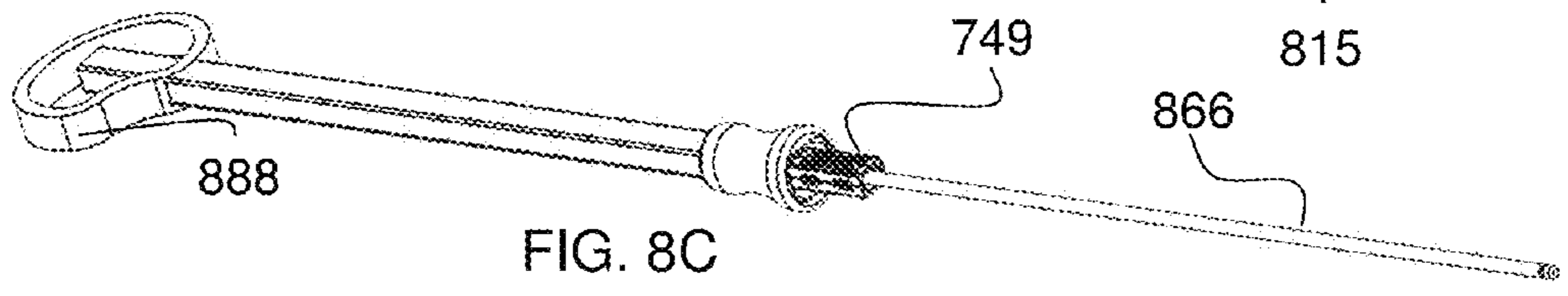

FIG. 8C

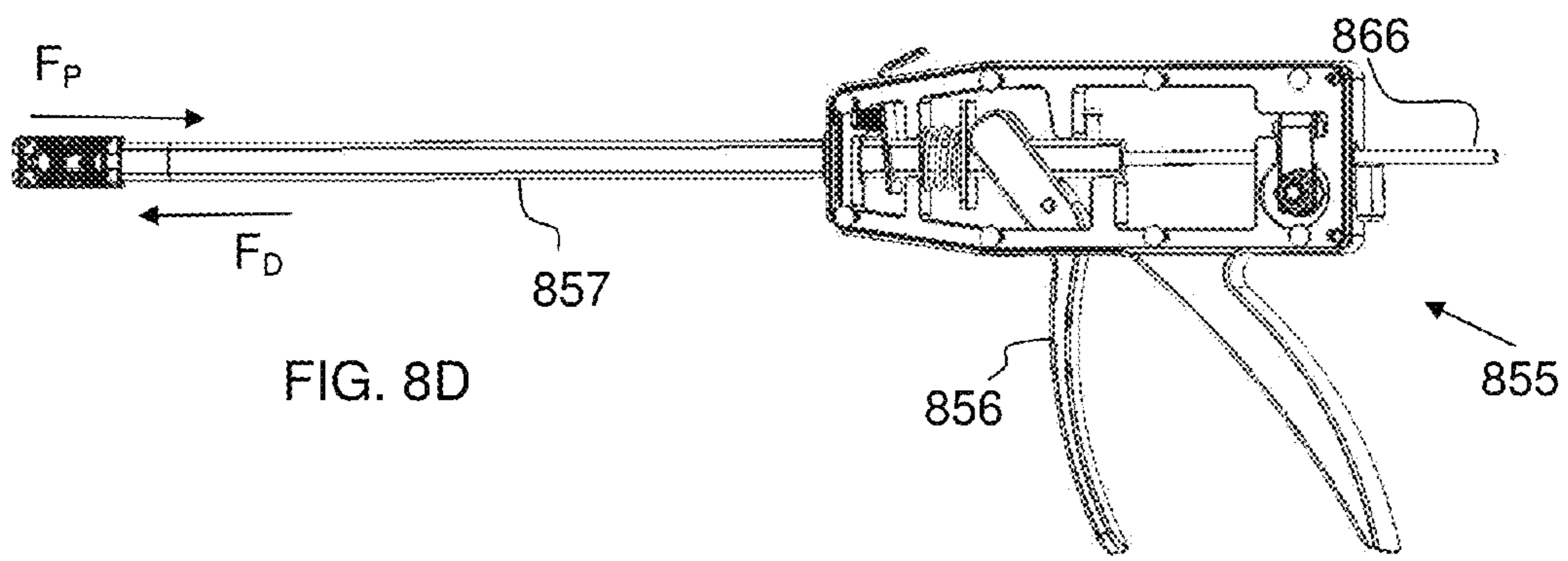

FIG. 8D

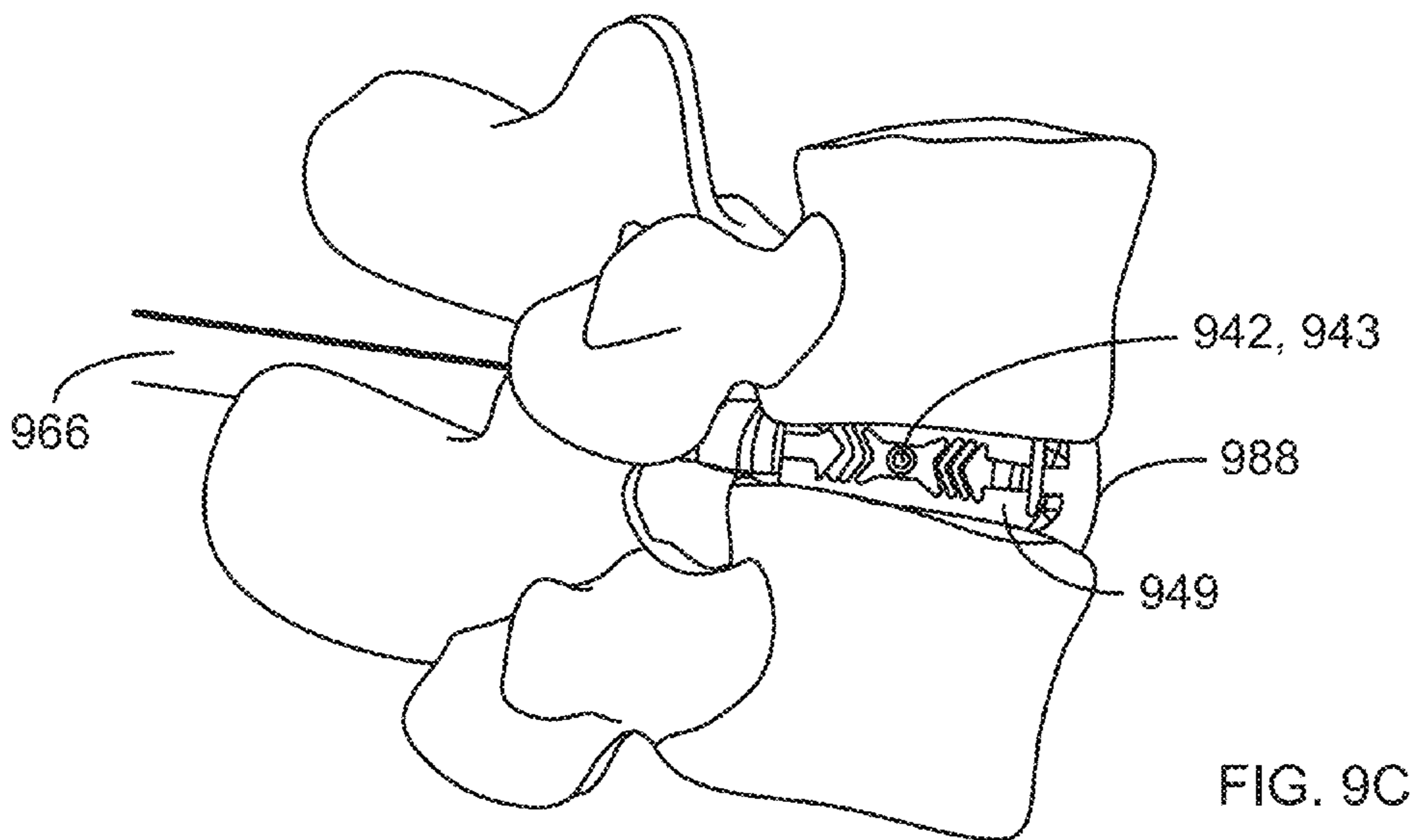
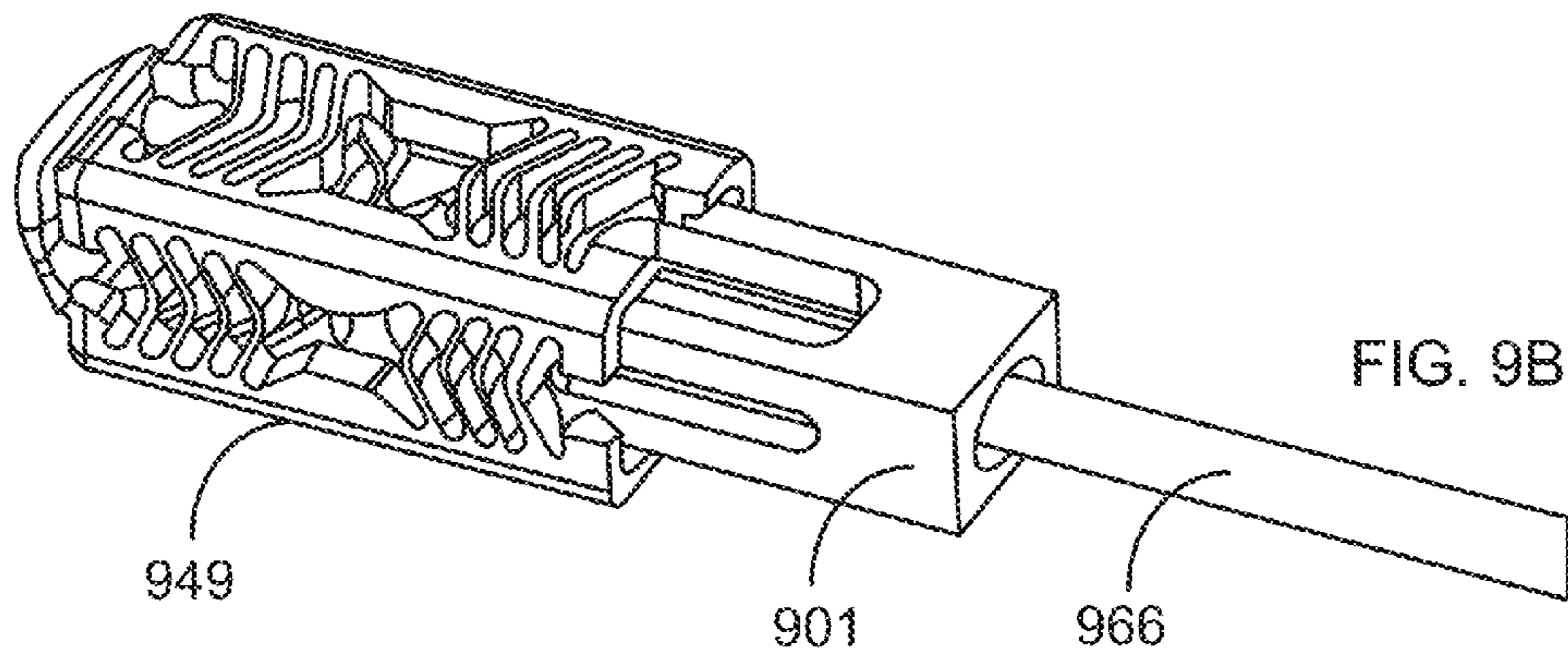
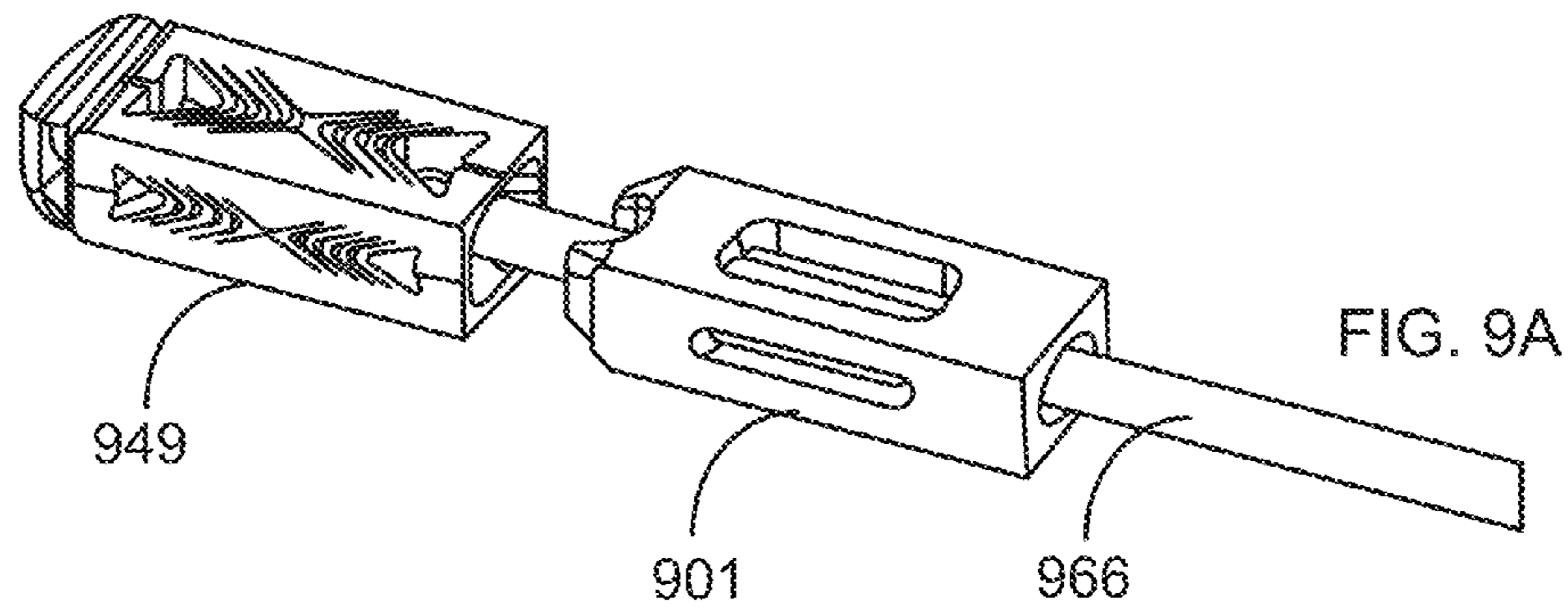
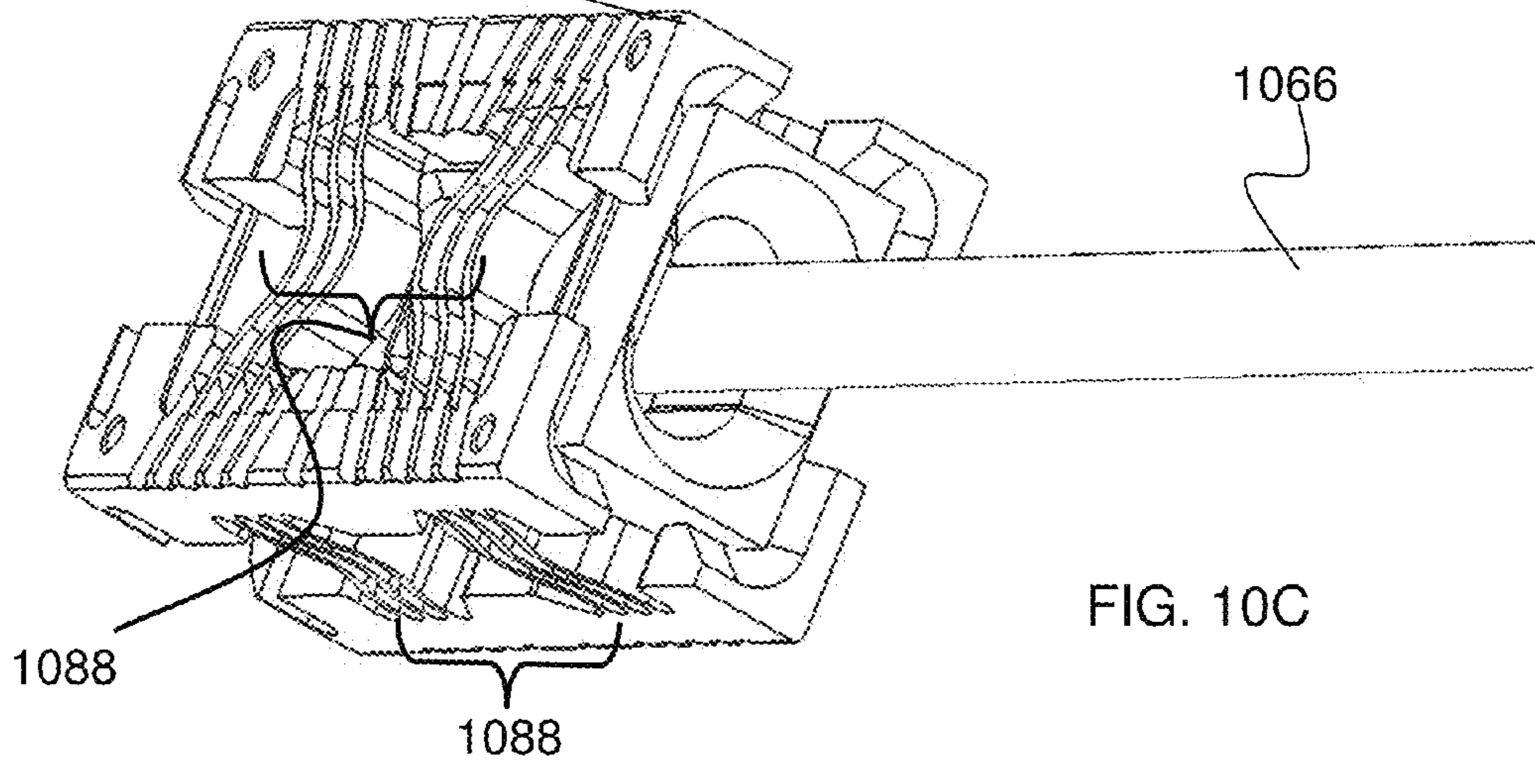
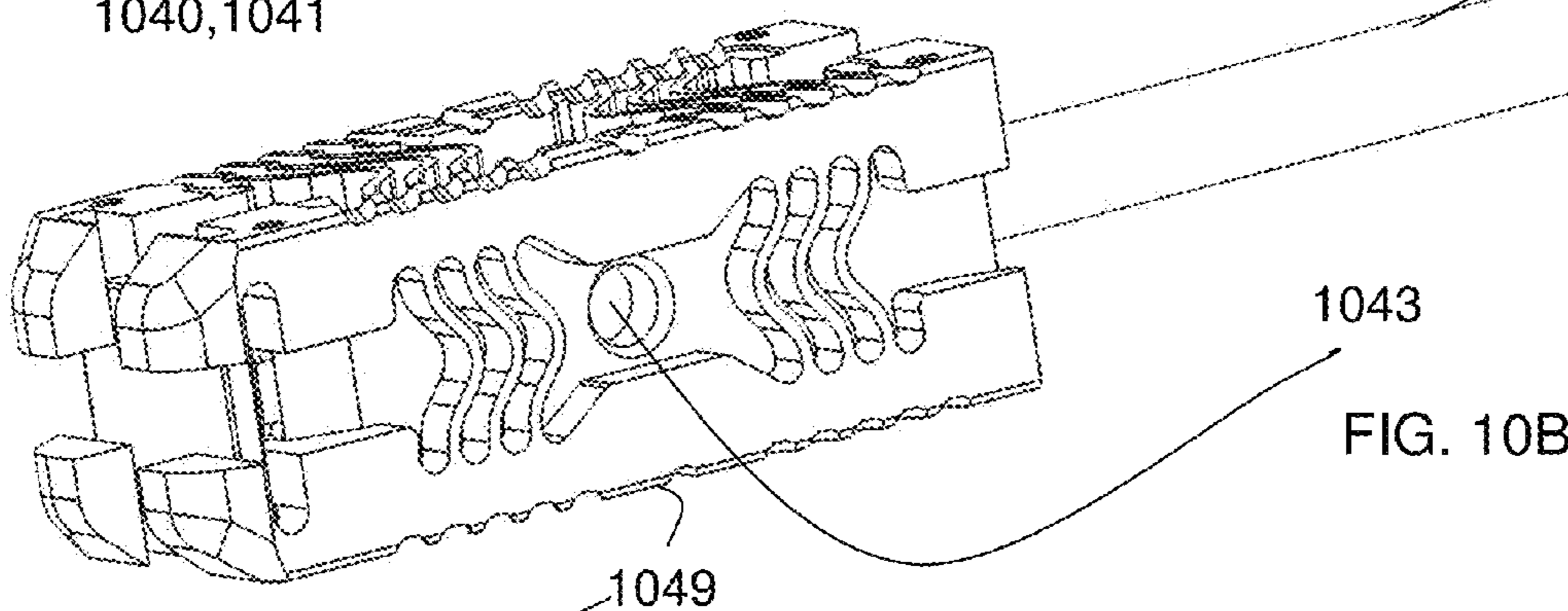
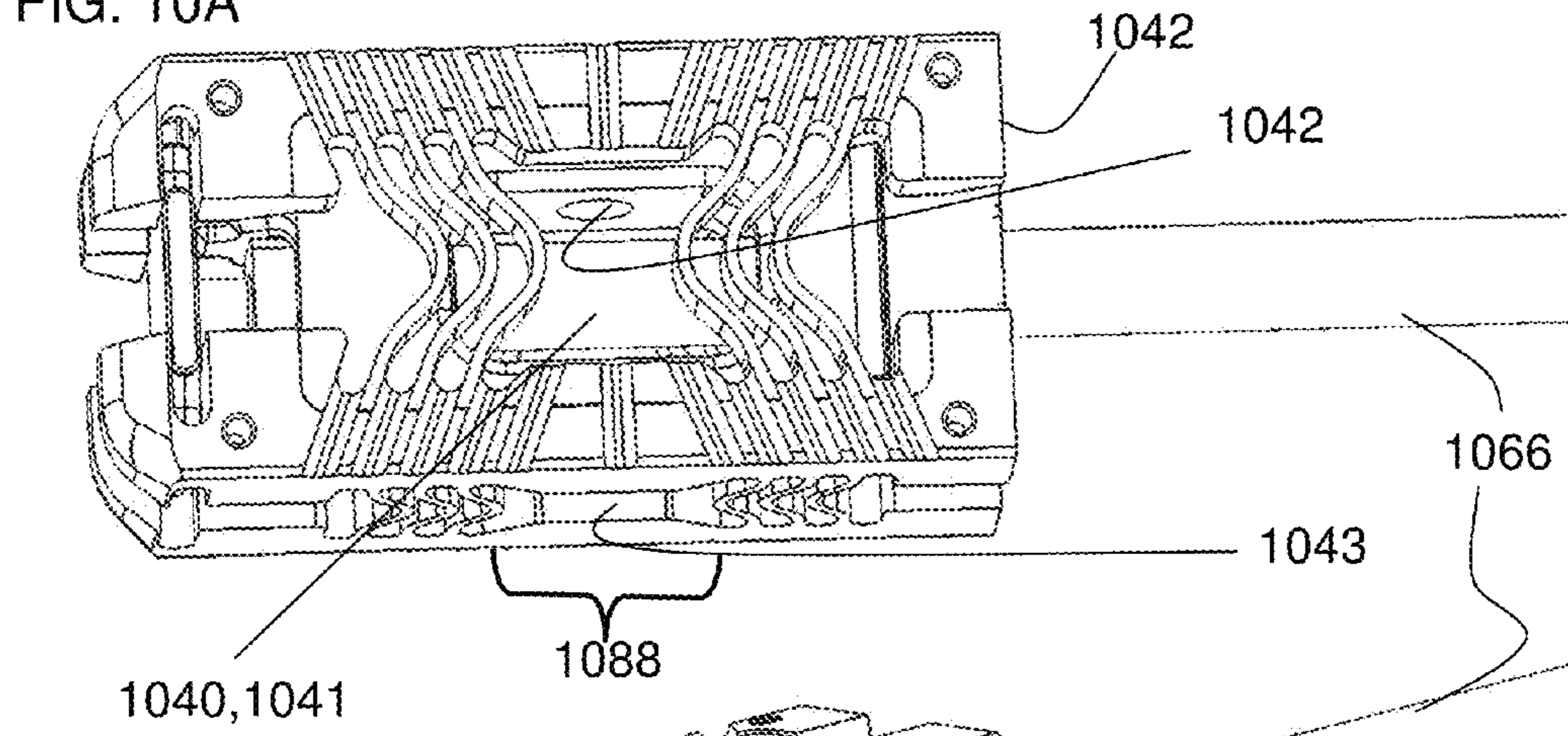

FIG. 10A



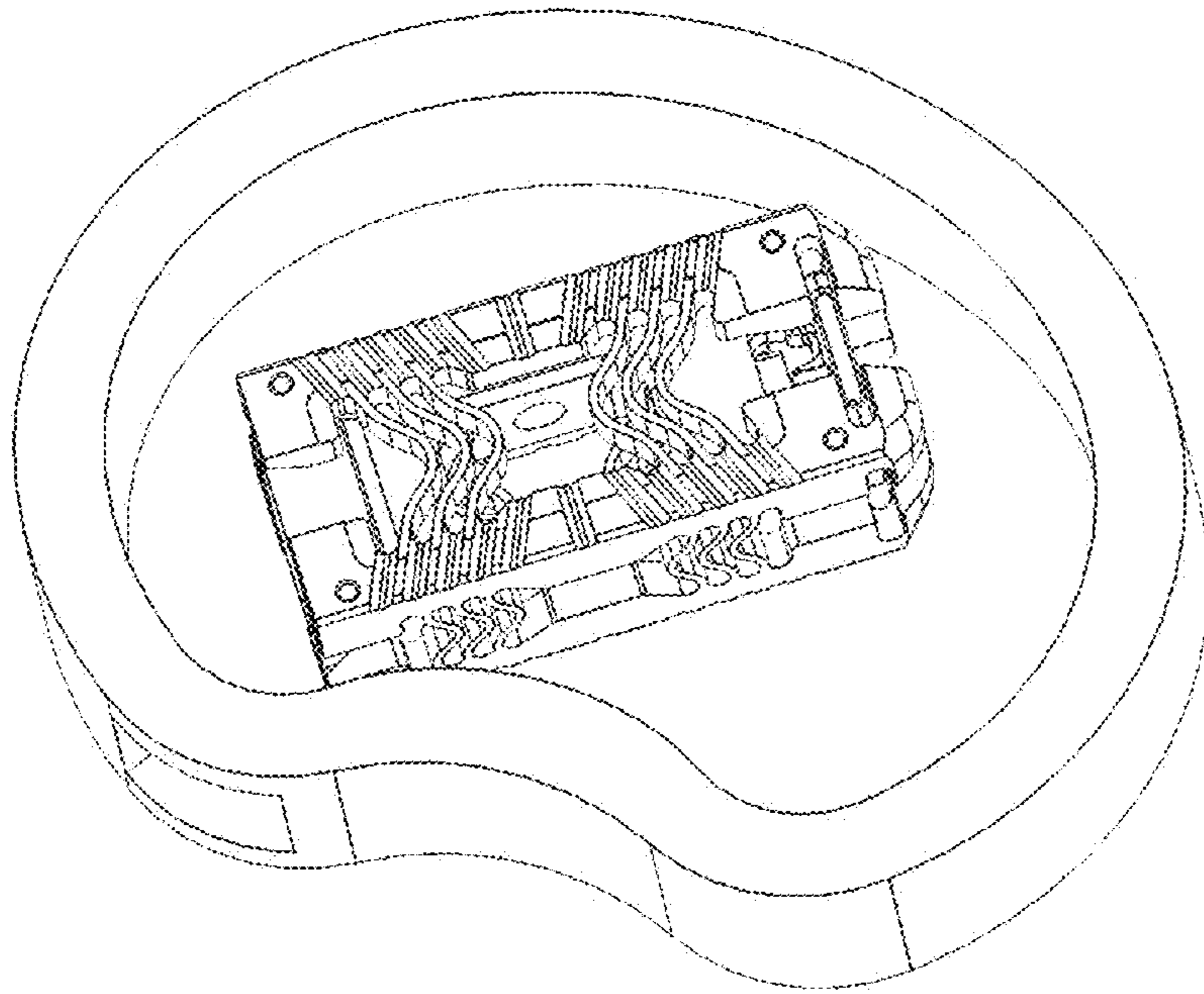

FIG. 11A

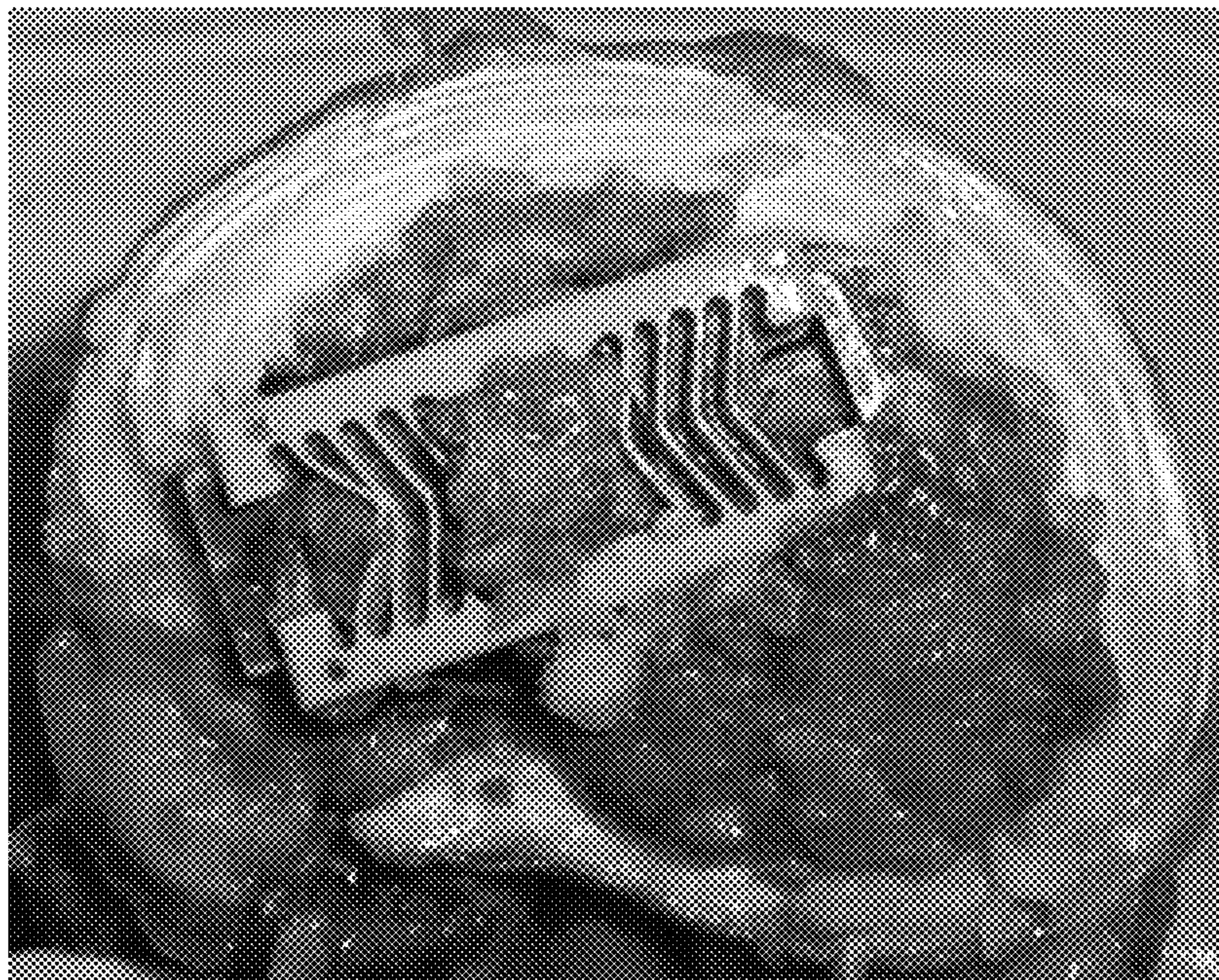

FIG. 11B

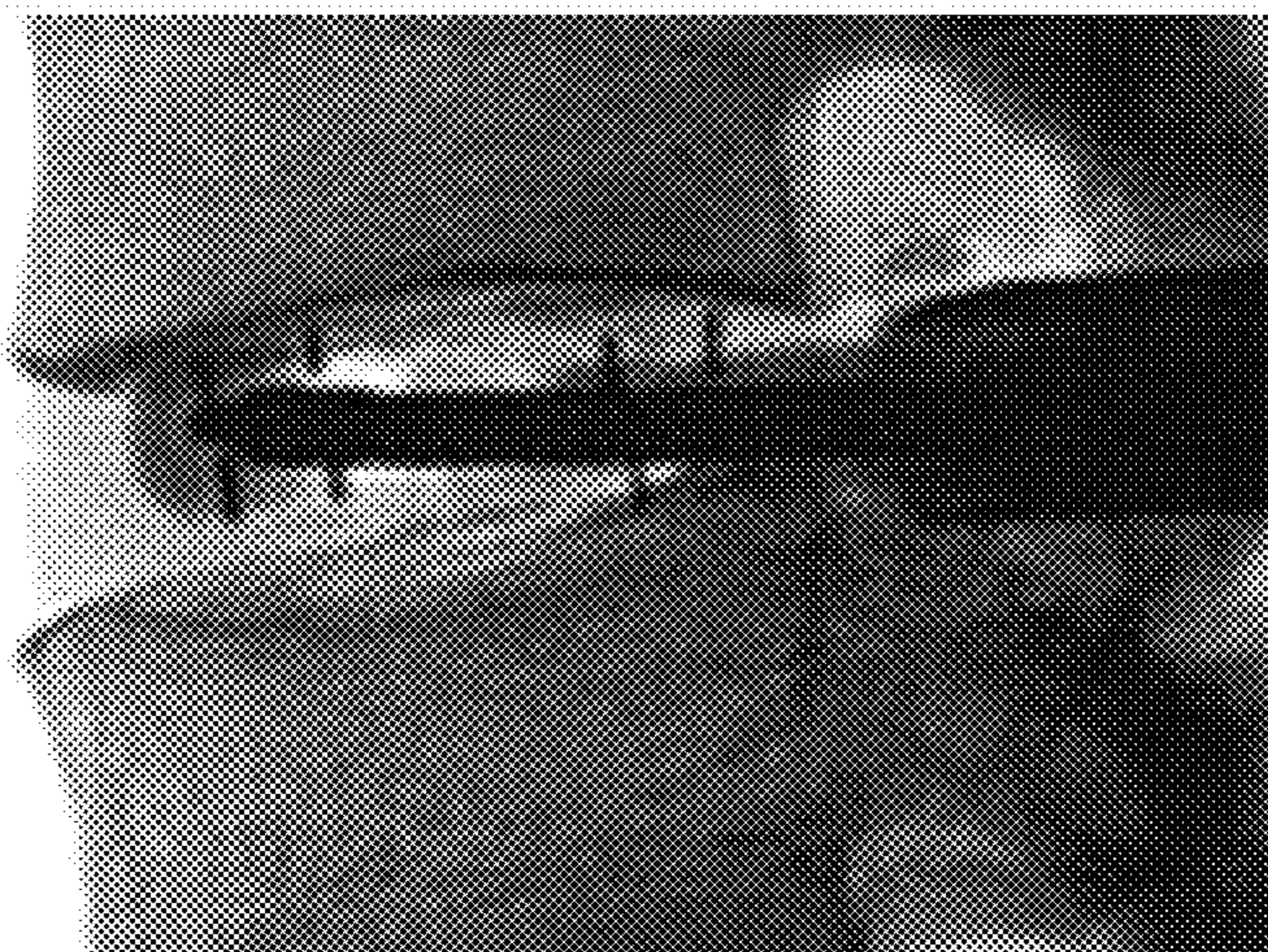

FIG. 12A

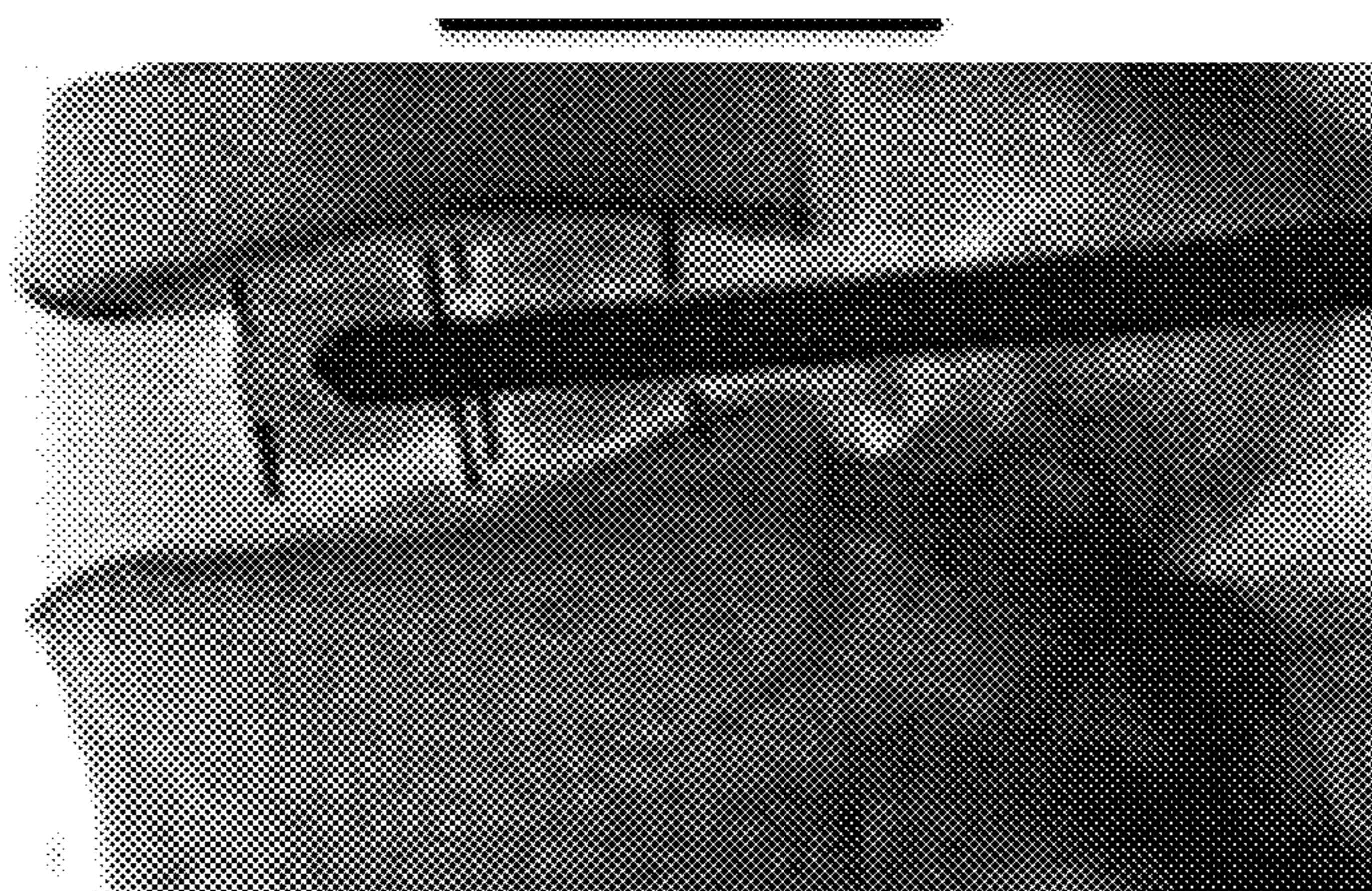

FIG. 12B

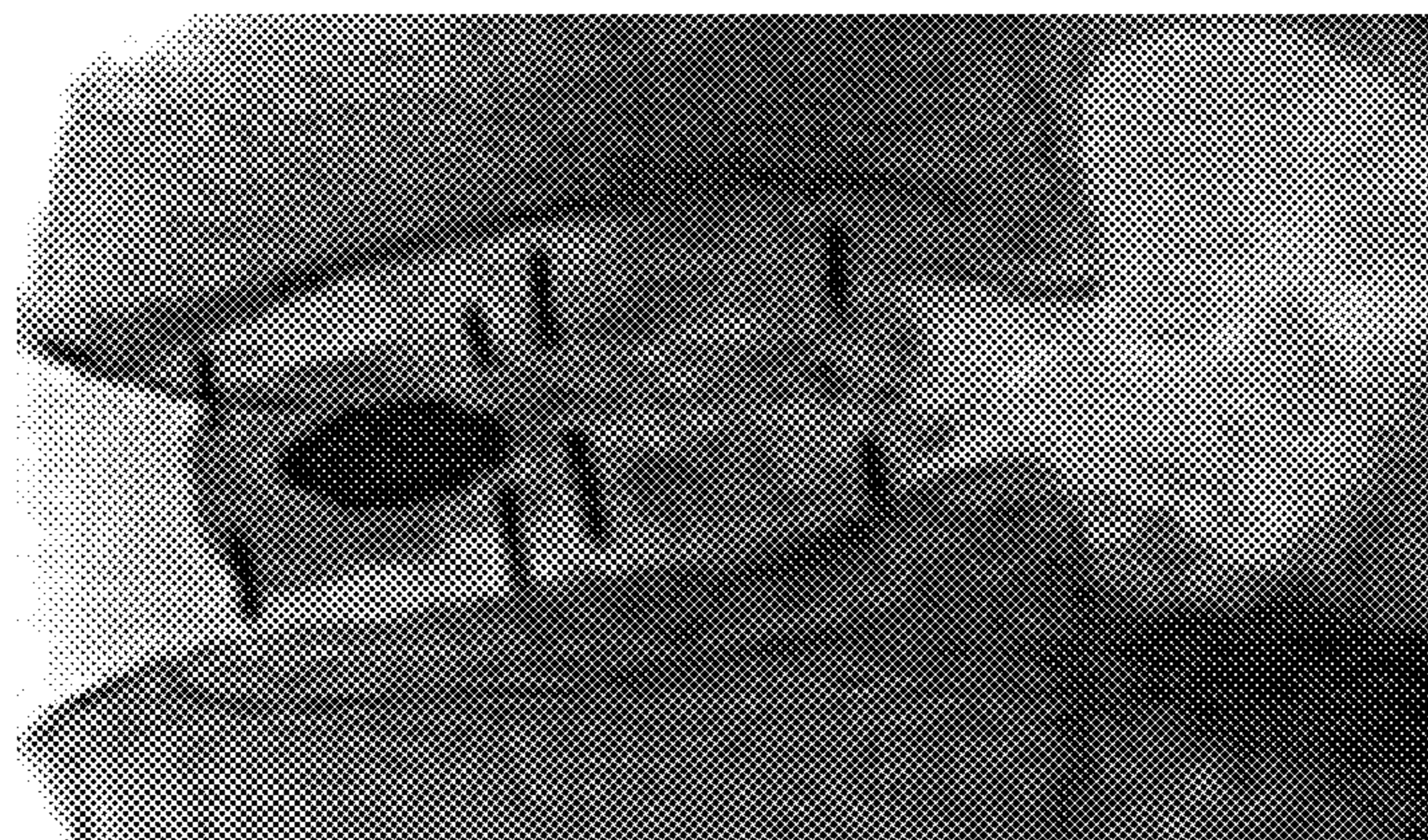

FIG. 12C

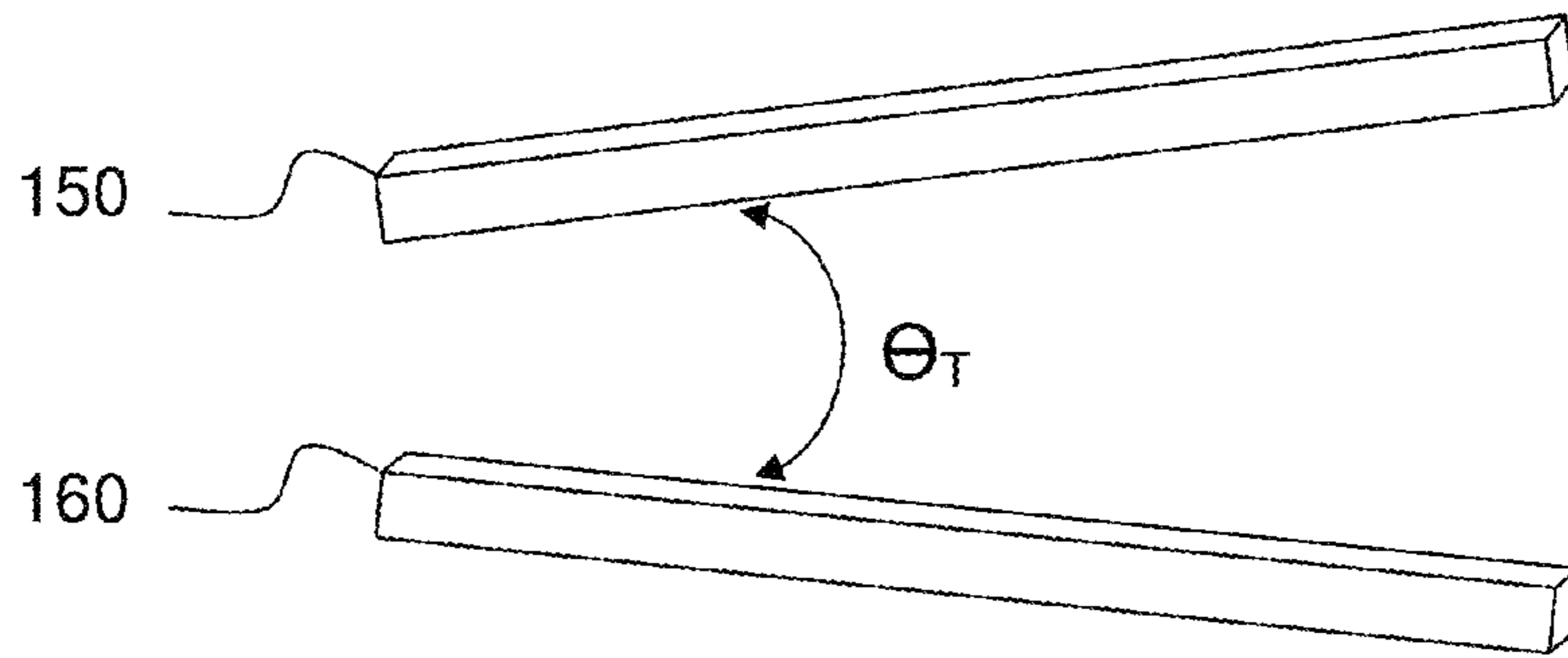

FIG. 13A

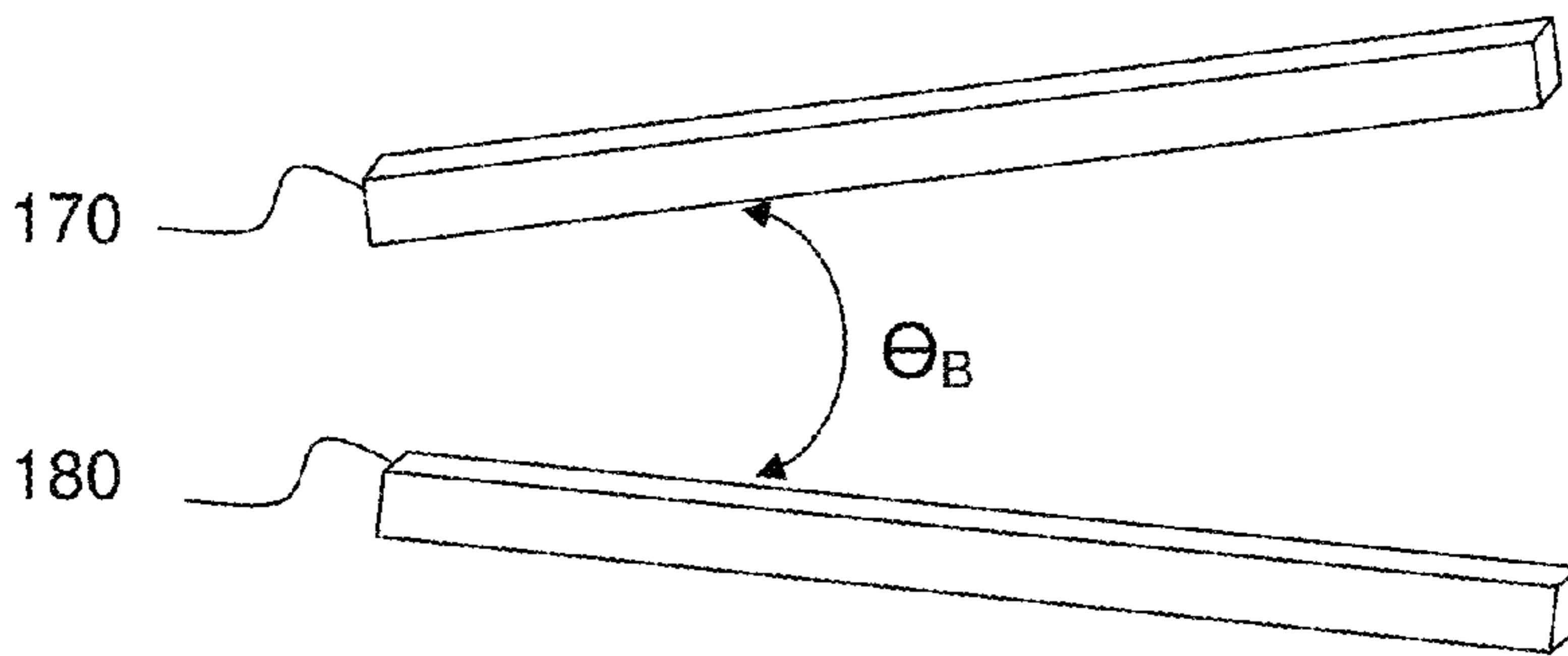

FIG. 13B

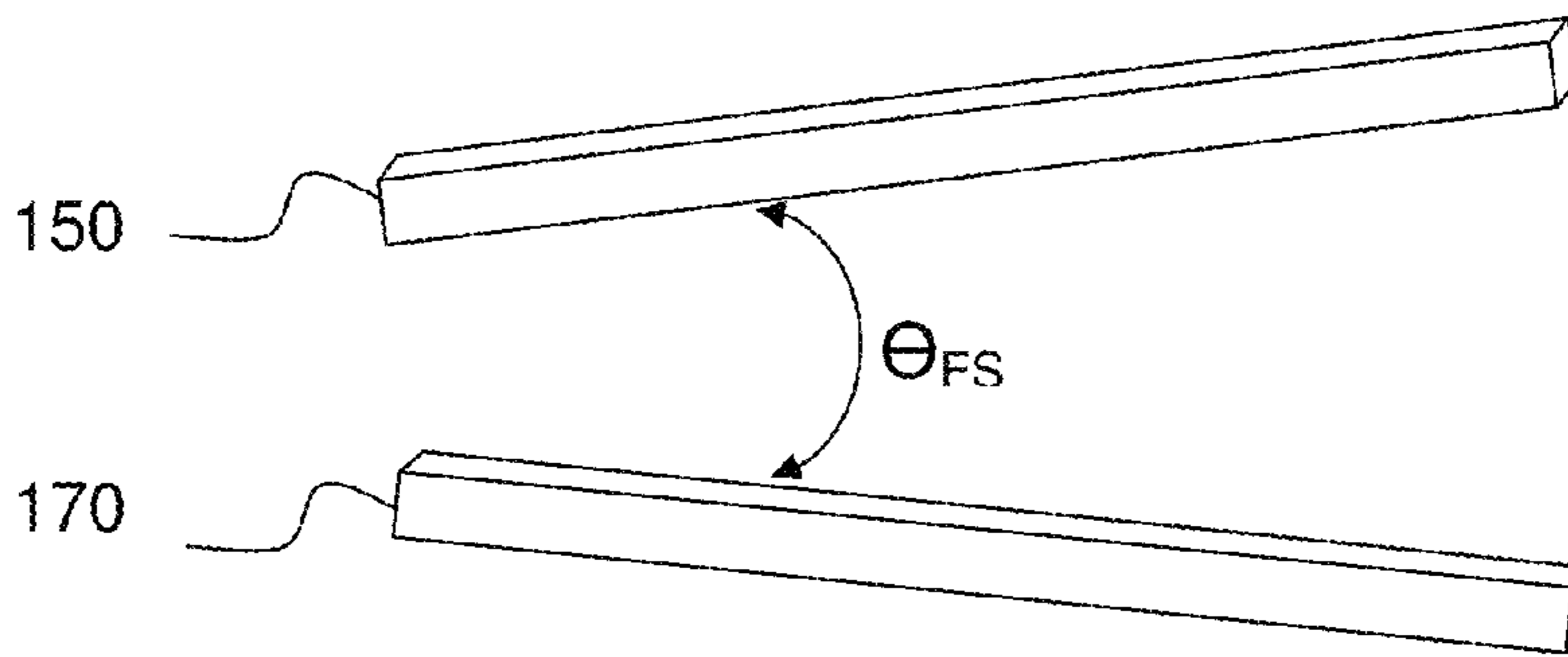

FIG. 13C

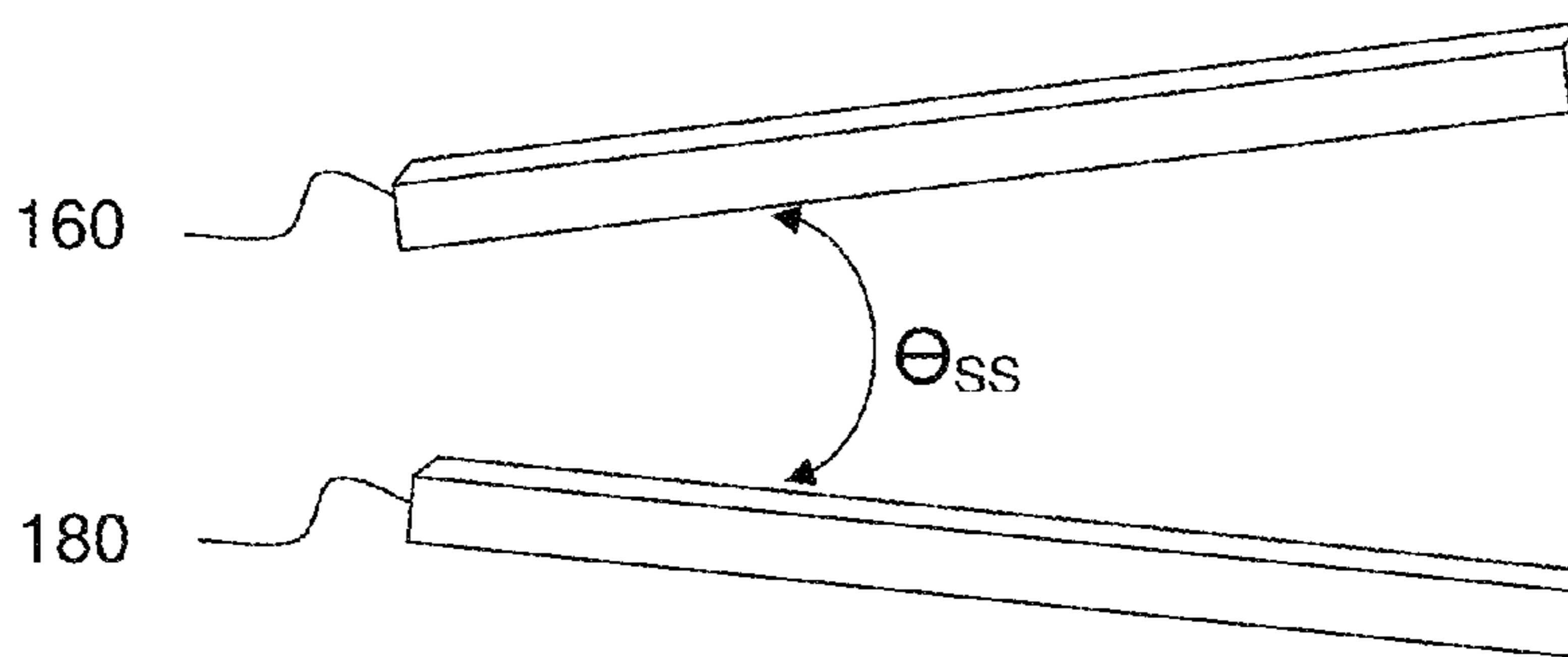
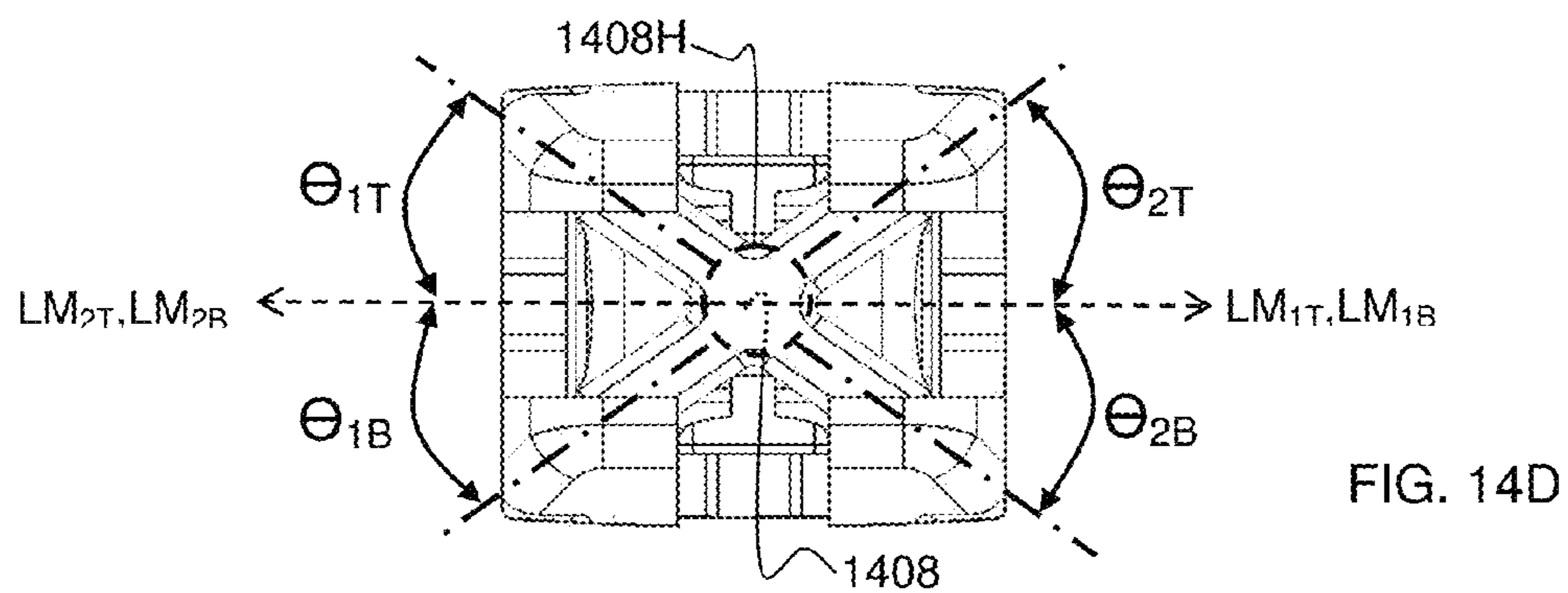
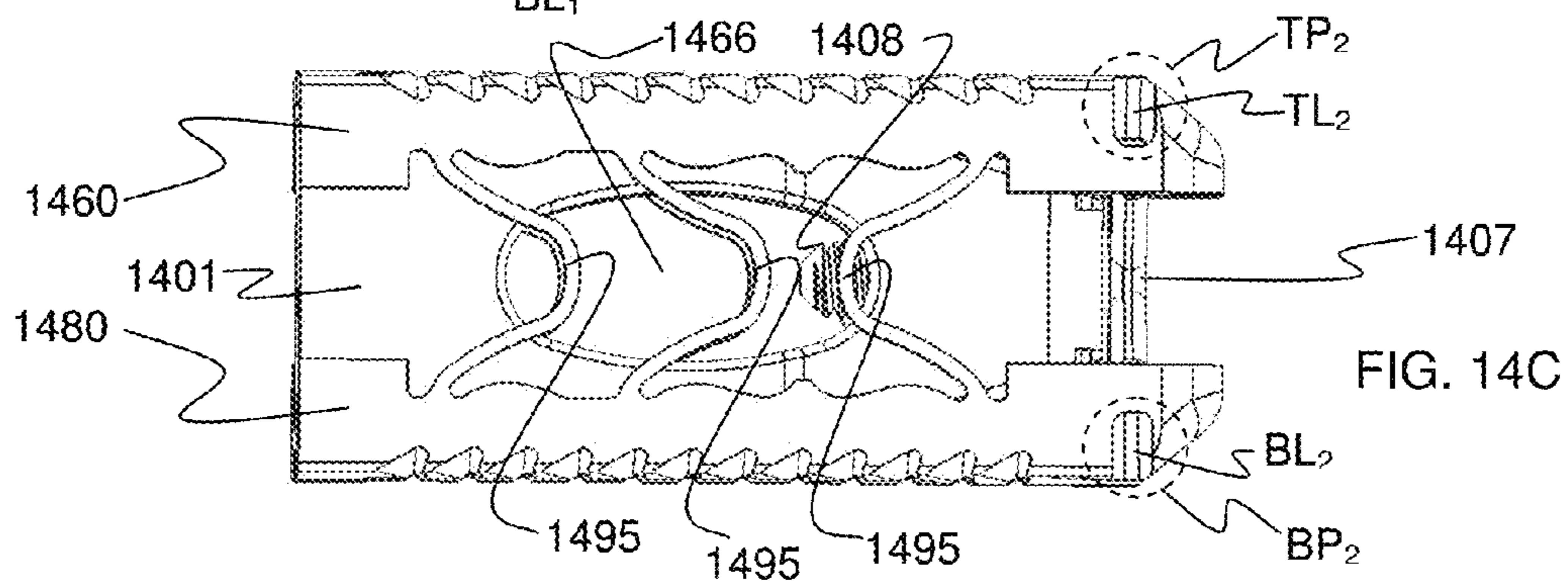
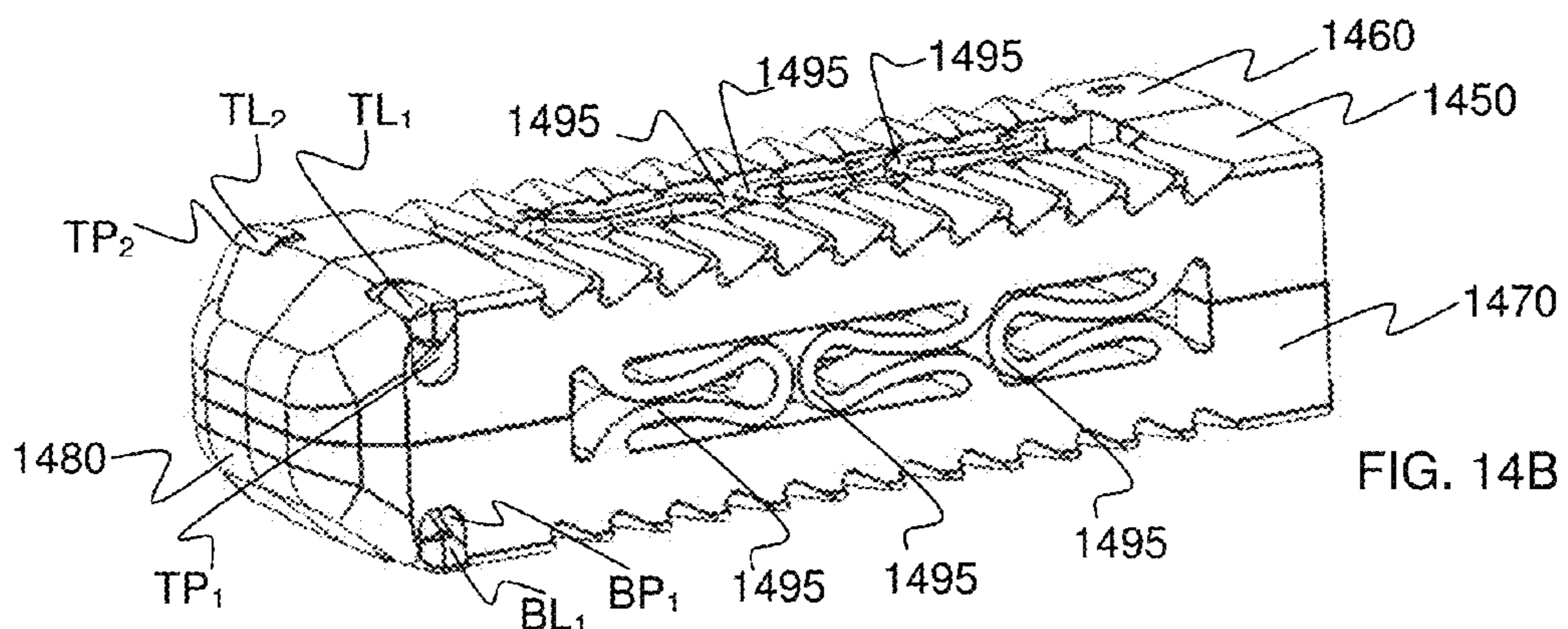
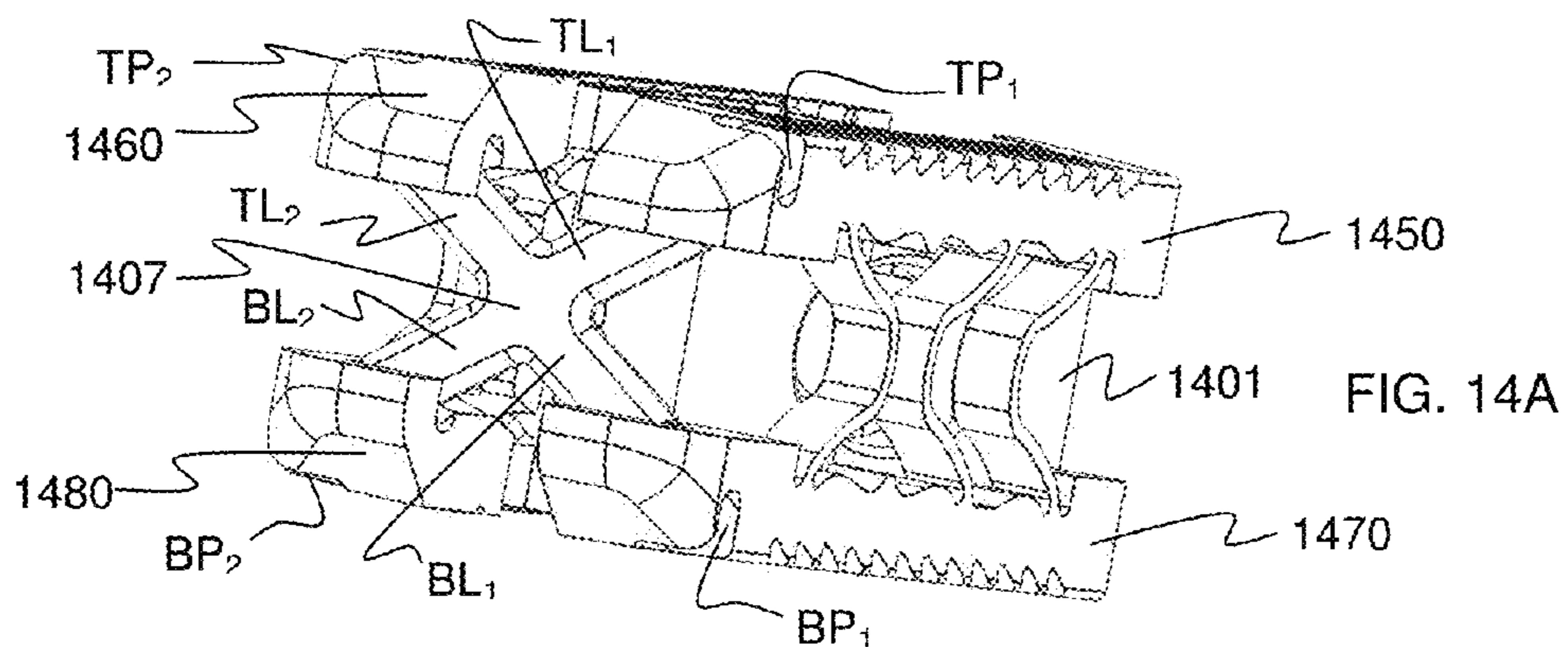
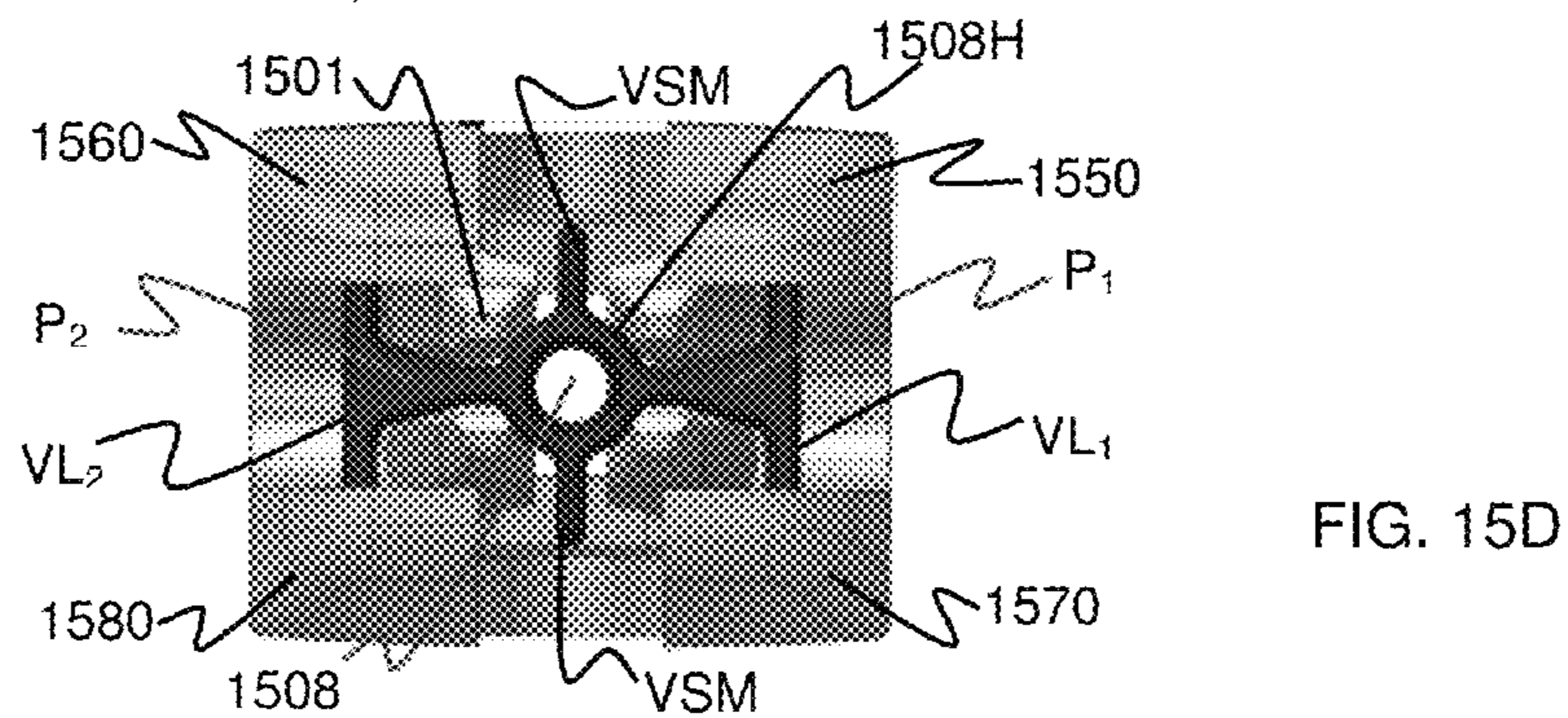
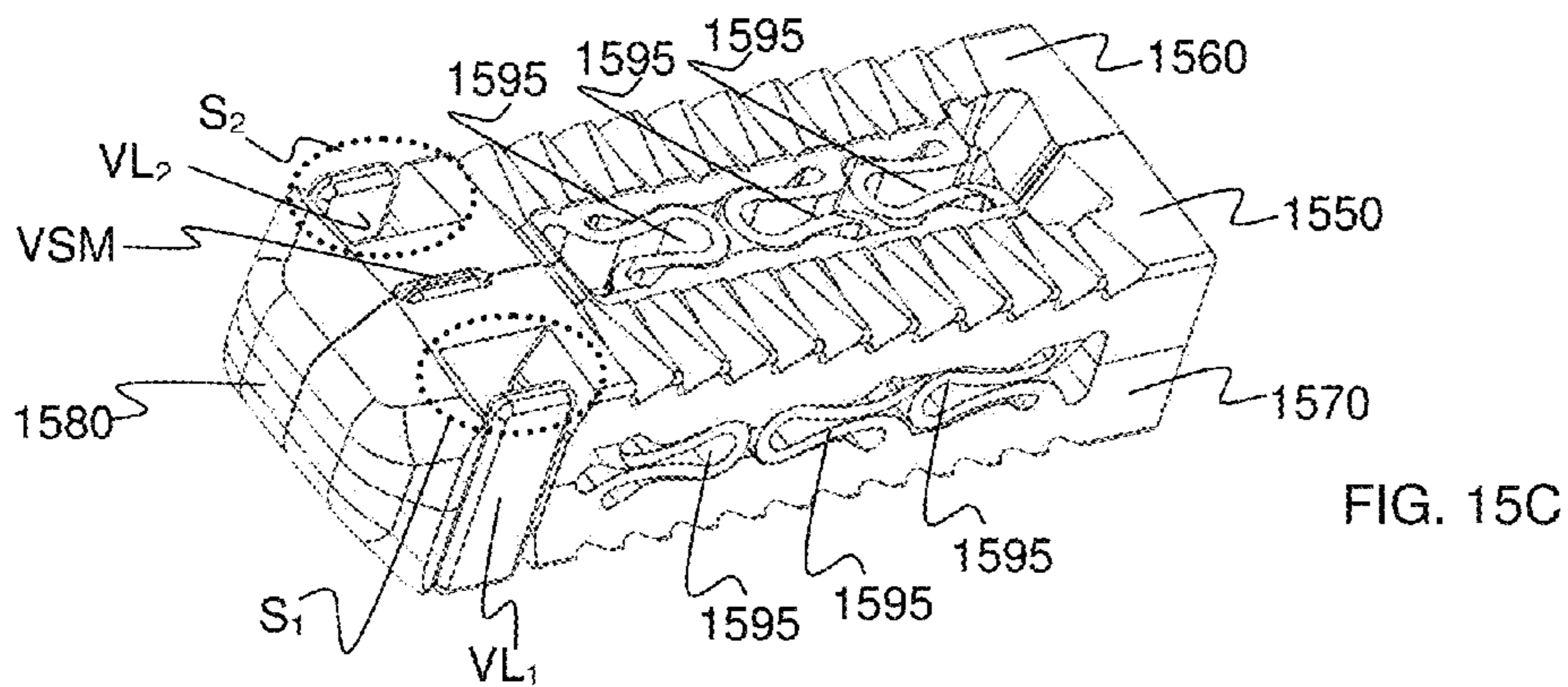
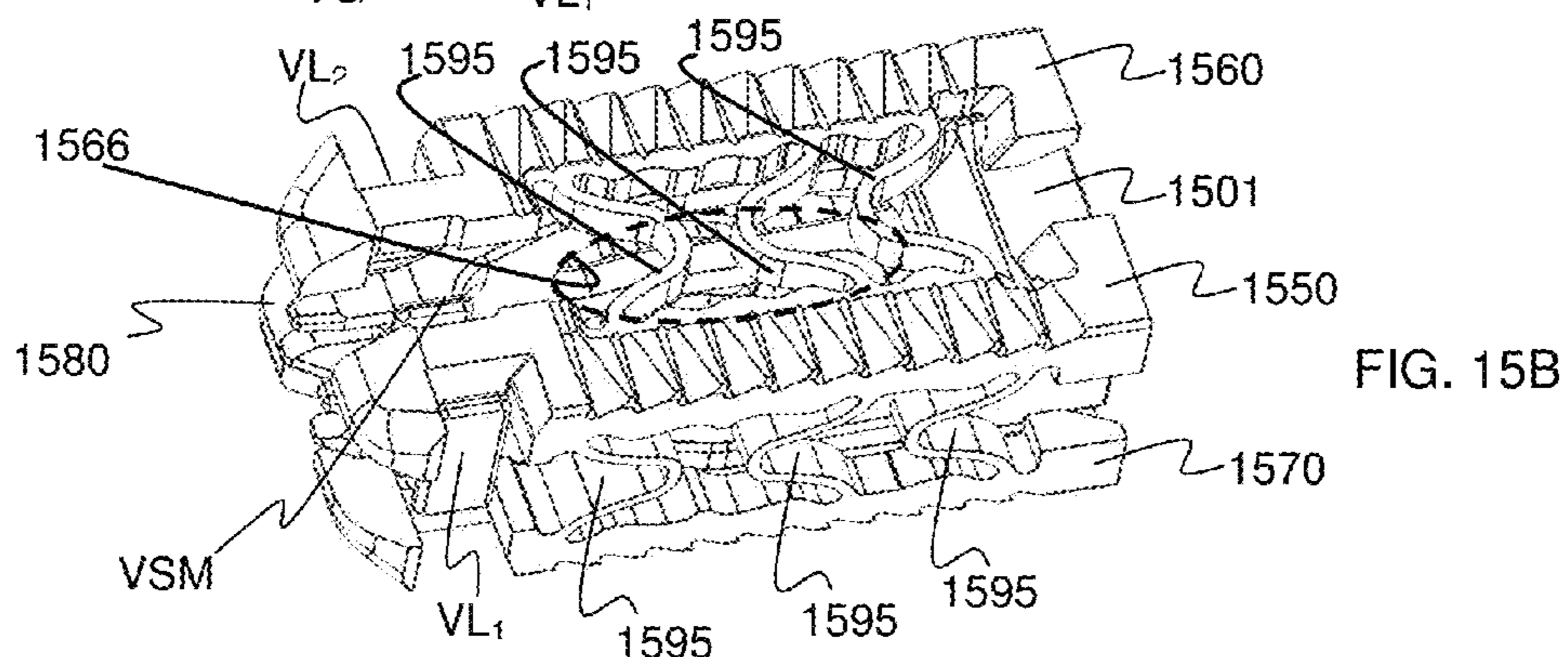
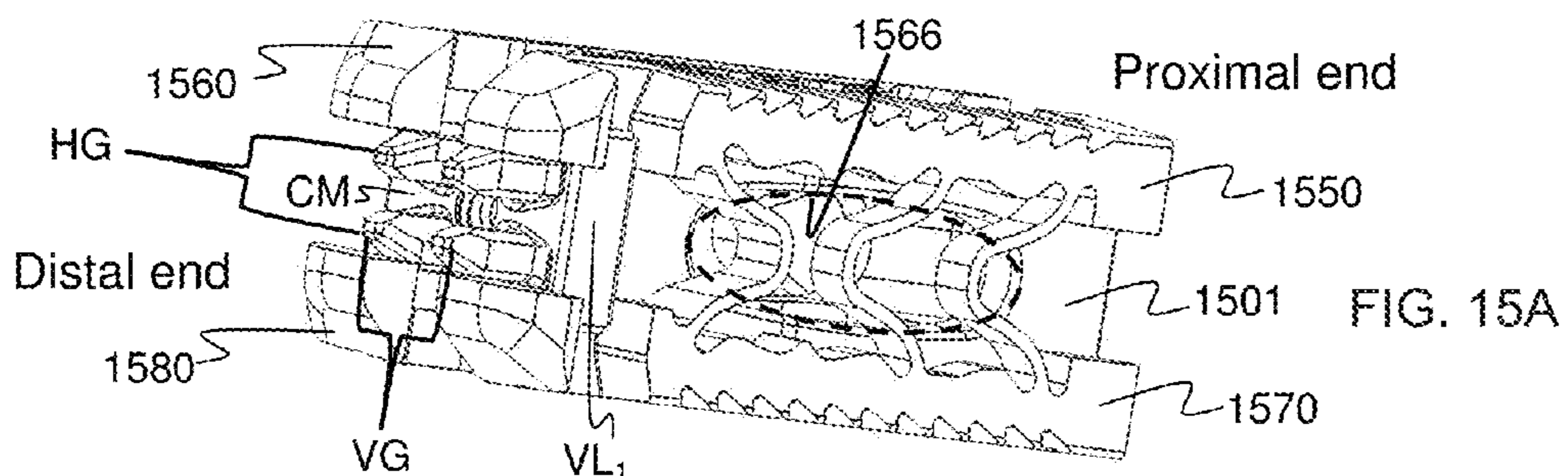

FIG. 13D





1
**STABILIZED,
 LATEROVERTICALLY-EXPANDING FUSION
 CAGE SYSTEMS**

CROSS-REFERENCE TO RELATED
 APPLICATIONS

This application is a continuation of U.S. application Ser. No. 14/600,617, filed Jan. 20, 2015, which is hereby incorporated herein by reference in its entirety.

BACKGROUND

1. Field of the Invention

The teachings herein are directed to intervertebral scaffolding systems having a stabilizer for stabilizing and/or retaining support beams upon expansion of the scaffolding in an intervertebral disc space.

2. Description of the Related Art

Bone grafts are used in spinal fusion, for example, which is a technique used to stabilize the spinal bones, or vertebrae, and a goal is to create a solid bridge of bone between two or more vertebrae. The fusion process includes “arthrodesis”, which can be thought of as the mending or welding together of two bones in a spinal joint space, much like a broken arm or leg healing in a cast. Spinal fusion may be recommended for a variety of conditions that might include, for example, a spondylolisthesis, a degenerative disc disease, a recurrent disc herniation, or perhaps to correct a prior surgery.

Bone graft material is introduced for fusion and a fusion cage can be inserted to help support the disc space during the fusion process. In fact, fusion cages are frequently used in such procedures to support and stabilize the disc space until bone graft unites the bone of the opposing vertebral endplates in the disc space. A transforaminal lumbar interbody fusion (TLIF), for example, involves placement of posterior instrumentation (screws and rods) into the spine, and the fusion cage loaded with bone graft can be inserted into the disc space. Bone graft material can be pre-packed in the disc space or packed after the cage is inserted. TLIF can be used to facilitate stability in the front and back parts of the lumbar spine promoting interbody fusion in the anterior portion of the spine. Fusion in this region can be beneficial, because the anterior interbody space includes an increased area for bone to heal, as well as to handle increased forces that are distributed through this area.

Unfortunately, therein lies a problem solved by the teachings provided herein. Currently available systems can be problematic in that the methods of introducing the fusion cage and bone graft material leaves pockets in regions of the intervertebral space that are not filled with bone graft material, regions in which fusion is desired for structural support. These pockets can create a premature failure of the fused intervertebral space due to forces that are distributed through the regions containing the pockets, for example, when the patient stands and walks.

Traditional fusion cages, such as the Medtronic CAPSTONE cage, are designed to be oversized relative to the disc space to distract the disc space as the entire cage is inserted. However, this makes it difficult to insert and position properly. In response to the problem, the art has developed a number of new fusion cages, such as the Globus CALIBER cage which can be inserted at a low height and expanded vertically to distract the disc space. Unfortunately, these types of devices have the typical graft distribution problem discussed above, in that they do not provide a path for bone graft to be inserted and fill in the space surrounding the cage or

2

within the cage. They have other problems as well, including that the annulotomy must be large to accommodate a large enough cage for stability, and this large opening necessitates more trauma to the patient. Moreover, they can also create the additional problem of “backout”, in that they cannot expand laterally beyond the annulotomy to increase the lateral footprint of the cage relative to lateral dimension of the annulotomy. Since it takes several months for the fusion to occur to completion in a patient, the devices have plenty of time to work their way out of the space through the large annulotomy.

Scaffolding systems may also suffer a lack of stability and/or a lack of a retention of structural components in a desired expansion configuration in the intervertebral space. As such, a multi-component scaffolding system, for example, can benefit from an improved design that adds stability through, for example, (i) enhancing the amount of contact between the scaffolding components upon expansion; and/or (ii) limiting the amount of expansion, or relative movement, that can occur between components upon expansion, or after expansion, in the intervertebral space. Such design considerations can, for example, address the problems of overexpansion of one component relative to another due to, for example, variable stresses that might occur in the intervertebral space upon expansion or after expansion, stresses which can result in at least partial failure of the scaffolding system in the intervertebral space.

Accordingly, and for at least the above reasons, those of skill in the art will appreciate bone graft distribution systems that facilitate an improved distribution of graft material throughout the intervertebral space. Such systems are provided herein, the systems configured to (i) effectively distribute bone graft material both from the system, and around the system, to improve the strength and integrity of a fusion; (ii) reduce or eliminate the problem of failures resulting from a poor bone graft distribution; (iii) have a small maximum dimension in a collapsed state for a low-profile insertion into the annulus in a minimally-invasive manner, whether using only a unilateral approach or a bilateral approach; (iv) laterally expand within the intervertebral space to avoid backout of the system through the annulotomy; (v) vertically expand for distraction of the intervertebral space; (vi) provide an expansion in the intervertebral space without contracting the system in length to maintain a large footprint and an anterior position adjacent to the inner, anterior annulus wall, distributing load over a larger area, anteriorly, against the endplates; (vii) and, incorporate a stabilizer for stabilizing and/or retaining support beams upon expansion of the scaffolding in an intervertebral disc space.

SUMMARY

The teachings herein are directed to intervertebral scaffolding systems having a stabilizer for stabilizing and/or retaining support beams upon expansion of the scaffolding in an intervertebral disc space. As such, the teachings herein are generally directed to an intervertebral scaffolding system.

The systems provided herein can comprise, for example, a central beam having a central beam axis; a proximal portion and a distal portion; a top surface with a first top-lateral surface and a second top-lateral surface; a bottom surface with a first bottom-lateral surface and a second bottom-lateral surface; a first side surface with a first top-side surface and a first bottom-side surface; and, a second side surface with a second top-side surface and a second bottom-side surface. The systems can also comprise a laterovertically-expanding frame configured for operably contacting the central beam to create an intervertebral scaffolding system in vivo. The frame

can have a collapsed state and an expanded state, the expanded state operably contacting with the central beam in the intervertebral space; a proximal portion having an end, a distal portion having an end, and a central frame axis of the expanded state.

In some embodiments, the frame can be constructed to have a first top beam including a proximal portion having an end and a distal portion having an end, the first top beam configured for contacting the first top-lateral surface of the central beam and the first top-side surface of the central beam in the expanded state, a central axis of the first top beam at least substantially on (i) a top plane containing the central axis of the first top beam and a central axis of a second top beam and (ii) a first side plane containing the central axis of the first top beam and a central axis of a first bottom beam; the second top beam including a proximal portion having an end and a distal portion having an end, the second top beam configured for contacting the second top-lateral surface of the central beam and the second top-side surface of the central beam in the expanded state, the central axis of the second top beam at least substantially on (i) the top plane and (ii) a second side plane containing the central axis of the second top beam and a central axis of a second bottom beam; the first bottom beam including a proximal portion having an end and a distal portion having an end, the first bottom beam configured for contacting the first bottom-lateral surface of the central beam and the first bottom-side surface of the central beam in the expanded state, the central axis of the first bottom beam at least substantially on (i) a bottom plane containing the central axis of the first bottom beam and the central axis of the second top beam and (ii) the first side plane; the second bottom beam including a proximal portion having an end and a distal region having an end, the second bottom beam configured for contacting the second bottom-lateral surface of the central beam and the second bottom-side surface of the central beam in the expanded state, the central axis of the second bottom beam being at least substantially on (i) the bottom plane and (ii) a second side plane containing the central axis of the second bottom beam and the central axis of the second top beam.

The frame can also be constructed, for example, to have a plurality of top connector elements configured to expandably connect the first top beam to the second top beam, the expanding consisting of a flexing at least substantially on the top plane; a plurality of bottom connector elements configured to expandably connect the first bottom beam to the second bottom beam, the expanding consisting of a flexing at least substantially on the bottom plane; a plurality of first side connector elements configured to expandably connect the first top beam to the first bottom beam, the expanding consisting of a flexing at least substantially on the first side plane; and, a plurality of second side connector elements configured to expandably connect the second top beam to the second bottom beam, the expanding consisting of a flexing at least substantially on the second side plane.

In some embodiments, the systems include a stabilizer that slidably engages with the distal region of the first top beam, the first bottom beam, the second top beam, the second bottom beam, or a combination thereof. The stabilizer can be configured for retaining the first top beam, the first bottom beam, the second top beam, the second bottom beam, or the combination thereof, from a lateral movement that exceeds the expanded state.

And, in some embodiments, the framing can be configured for engaging with the central beam in vivo to support the framing in the expanded state. Moreover, the connector elements can be struts configured to have a cross-sectional aspect ratio of longitudinal thickness to transverse thickness

ranging from 1:2 to 1:8, adapted to maintain structural stiffness in the laterover vertically expanding frame in a direction perpendicular to the central frame axis of the expanded state of the frame.

The stabilizer can be in an X-configuration. In some embodiments, the X-configuration can have a first top leg for slidably engaging with the first top beam at an angle θ_{1T} with the lateral movement of the first top beam, first bottom leg for slidably engaging with the first bottom beam at an angle θ_{1B} with the lateral movement of the first bottom beam, a second top leg for slidably engaging with the second top beam at an angle θ_{2T} with the lateral movement of the second top beam, and a second bottom leg for slidably engaging with the second bottom beam at an angle θ_{2B} with the lateral movement of the second bottom beam. In some embodiments, each of the angles θ_{1T} , θ_{1B} , θ_{2T} , θ_{2B} , respectively, provide a tensile force for resisting the first top beam, the first bottom beam, the second top beam, and the second bottom beam from the lateral movement that exceeds the expanded state. In some embodiments, the stabilizer further comprises a point of attachment for releasably attaching a guidewire for guiding the central beam into the laterover vertically expanding frame. And, in some embodiments, the first top leg, the first bottom leg, the second top leg, and the second bottom leg converge to form a hub having a point of attachment for releasably attaching a guidewire for guiding the central beam into the laterover vertically expanding frame.

The stabilizer can be in an H-configuration. The H-configuration can have a first vertical leg, a second vertical leg, and a cross-member that connects the first vertical leg at least substantially parallel to the second vertical leg, the first vertical leg including a retaining surface for engaging with the first top beam and the first bottom beam, the second vertical leg including a retaining surface for engaging with the second top beam and the second bottom beam, and the cross member providing a tensile force for resisting the first top beam, the first bottom beam, the second top beam, and the second bottom beam from the lateral movement that exceeds the expanded state. In some embodiments, the central beam has a horizontal groove configured complementary to the cross-member of the stabilizer, and the horizontal groove of the central beam slidably connects with the cross-member in the expanded state. In some embodiments, the cross-member further comprises a vertical support member and the central beam has a vertical groove configured complementary to the vertical support member of the stabilizer, and the vertical groove of the central beam slidably connects with the vertical support member in the expanded state. In some embodiments, the stabilizer further comprises a point of attachment for releasably attaching a guidewire adapted for guiding the central beam into the laterover vertically expanding frame. And, in some embodiments, cross-member includes a first pillar and a second pillar that operably connect at a hub that has a point of attachment for releasably attaching a guidewire for guiding the central beam into the laterover vertically expanding frame.

In some embodiments, the systems are bone graft distribution systems. In these embodiments, the central beam can further comprise a grafting port. Likewise the expanding frame can open bone graft distribution windows on the top, the bottom, the sides, or a combination thereof, upon expansion.

In some embodiments, the frame can be formed monolithically. In these embodiments, each plurality connector elements can be struts; wherein, the top struts are configured monolithically integral to the first top beam and the second top beam; and, the bottom struts are configured monolithically integral to the first bottom beam and the second bottom

5

beam. The top struts and the bottom struts of the laterover-
 tically-expanding frame can each be configured to open a graft
 distribution window upon expansion, expanding from the first
 top beam to the second top beam, the first top beam to the first
 bottom beam, the second top beam to the second bottom beam,
 or the first bottom beam to the second bottom beam. Likewise,
 in some embodiments, the top connector struts are configured
 monolithically integral to the first top beam and the second
 top beam; and, the bottom struts are configured monolithically
 integral to the first bottom beam and the second bottom beam;
 the first side struts are configured monolithically integral to
 the first top beam and the first bottom beam; and, the second
 side struts are configured monolithically integral to the second
 top beam and the second bottom beam. It should be appreciated
 that, in such embodiments, the top, bottom, first side, and
 second side of the laterover-vertically-expanding frame can
 form a monolithically integral frame.

The teachings are also directed to a method of fusing an
 intervertebral space. The methods can use the scaffolding
 systems taught herein. For example, the methods can include
 creating a point of entry into an intervertebral disc, the inter-
 vertebral disc having a nucleus pulposus surrounded by an
 annulus fibrosis; removing the nucleus pulposus from within
 the intervertebral disc through the point of entry, leaving the
 intervertebral space for expansion of the scaffolding system
 of claim 1 within the annulus fibrosis, the intervertebral
 space having a top vertebral plate and a bottom vertebral
 plate; inserting the laterover-vertically expanding frame in
 the collapsed state through the point of entry into the inter-
 vertebral space; inserting the central beam into the frame to
 form the scaffolding system; and, adding a grafting material
 to the intervertebral space.

The step of creating the point of entry can comprise creat-
 ing a lateral dimension of the point of entry ranging from
 about 5 mm to about 15 mm, and the amount of lateral
 expansion can be selected to exceed the lateral dimension of
 the point of entry. The step of expanding can include expand-
 ing the laterover-vertically expanding frame laterally to a
 width that exceeds the width of the point of entry; and,
 inserting the central beam to expand the laterover-vertically
 expanding frame vertically to support the frame in the ex-
 panded state. The step of inserting the central beam into the
 laterover-vertically expanding frame includes engaging a
 means for preventing the central beam from backing out of
 the laterover-vertically-expanding frame after the expanding.

The teachings are also directed to a kit comprising a scaf-
 folding system taught herein. The systems can include a can-
 nula for inserting the scaffolding system into the interverte-
 bral space; and, a guidewire adapted for guiding the central
 beam into the laterover-vertically expanding frame.

BRIEF DESCRIPTION OF THE FIGURES

FIGS. 1A-1I illustrate components of the graft distribution
 system, according to some embodiments.

FIGS. 2A-2F illustrate a method of using a bidirectionally-
 expandable cage, according to some embodiments.

FIGS. 3A-3D illustrate a bidirectionally-expandable cage
 for fusing an intervertebral disc space, according to some
 embodiments.

FIGS. 4A and 4B illustrate collapsed and expanded views
 of a bidirectionally-expandable cage having a bone graft win-
 dow on each wall for fusing an intervertebral disc space,
 according to some embodiments.

FIGS. 5A-5D illustrate system for fusing an intervertebral
 disc space, according to some embodiments.

6

FIG. 6 is a diagram of a method of using a bidirectionally-
 expandable cage, according to some embodiments.

FIGS. 7A-7F illustrate some additional features of graft
 distribution systems, according to some embodiments.

FIGS. 8A-8D illustrate components of a graft distribution
 kit, according to some embodiments.

FIGS. 9A-9C illustrate the expansion of a laterover-vertically-
 expandable frame in an intervertebral space, according to
 some embodiments.

FIGS. 10A-10C illustrate profiles of an expanded graft
 distribution system to highlight the exit ports and bone graft
 windows, according to some embodiments.

FIGS. 11A and 11B compare an illustration of the graft
 distribution in place to a test placement in a cadaver to show
 relative size, according to some embodiments.

FIGS. 12A-12C show x-rays of a placement in a cadaver,
 according to some embodiments.

FIGS. 13A-13D show orientations of the first top beam
 relative to the second top beam, first bottom beam relative to
 the second bottom beam, first top beam relative to the first
 bottom beam, and the second top beam relative to the second
 bottom beam, according to some embodiments.

FIGS. 14A-14D illustrate components of a system having
 a stabilizer, wherein the stabilizer is in an X-configuration,
 according to some embodiments.

FIGS. 15A-15D illustrate components of a system having
 a stabilizer, wherein the stabilizer is in an H-configuration,
 according to some embodiments.

DETAILED DESCRIPTION OF THE INVENTION

The teachings herein are directed to intervertebral scaffold-
 ing systems having a stabilizer for stabilizing and/or retaining
 support beams upon expansion of the scaffolding in an inter-
 vertebral disc space. The systems can have, for example, a
 central beam having a proximal portion having an end, a
 grafting portion having a top and a bottom, a distal portion
 having an end, a central beam axis, a graft distribution channel
 having an entry port at the end of the proximal portion, a top
 exit port at the top of the grafting portion, and a bottom
 exit port at the bottom of the grafting portion. These systems
 can also include a laterover-vertically-expanding frame hav-
 ing a lumen, a first top beam, a second top beam, a first bot-
 tom beam, and a second bottom beam, each having a proximal
 portion and a distal portion, and each operably connected to
 each other at their respective proximal portions and distal
 portions with connector elements to form the laterover-verti-
 cally-expanding frame that is operable for a reversible col-
 lapse from an expanded state into a collapsed state. The ex-
 panded state, for example, can be configured to have an open
 graft distribution window that at least substantially closes upon
 the reversible collapse. In these embodiments, the laterover-
 vertically-expanding frame is adapted for receiving an inser-
 tion of the central beam to form the graft distribution system.

In some embodiments, the systems can also include a lat-
 erovertically-expanding frame having a first top beam, a sec-
 ond top beam, a first bottom beam, and a second bottom
 beam; wherein, the beams are in an at least substantially
 parallel arrangement with each other, each having a proximal
 portion, a grafting portion, and a distal portion, and each
 operably connected to each other at their respective proximal
 portions and distal portions to form the laterover-vertically-
 expanding frame in a square, cylindrical shape that is operable
 for a reversible collapse from an expanded state into a col-
 lapsed state. The expanded state, for example, can be config-
 ured to have an open graft distribution window that at least
 substantially closes upon the reversible collapse. In these

embodiments, the laterovertically-expanding frame is adapted for receiving an insertion of the central beam to form the graft distribution system.

The term “subject” and “patient” can be used interchangeably in some embodiments and refer to an animal such as a mammal including, but not limited to, non-primates such as, for example, a cow, pig, horse, cat, dog; and primates such as, for example, a monkey or a human. As such, the terms “subject” and “patient” can also be applied to non-human biologic applications including, but not limited to, veterinary, companion animals, commercial livestock, and the like. Moreover, terms of degree are used herein to provide relative relationships between the position and/or movements of components of the systems taught herein. For example, the phrase “at least substantially parallel” is used to refer to a position of one component relative to another. An axis that is at least substantially parallel to another axis refers to an orientation that is intended, for all practical purposes to be parallel, but it is understood that this is just a convenient reference and that there can be variations due to stresses internal to the system and imperfections in the devices and systems. Likewise, the phrase “at least substantially on a . . . plane” refers to an orientation or movement that is intended, for all practical purposes to be on or near the plane as a convenient measure of the orientation or movement, but it is understood that this is just a convenient reference and that there can be variations due to stresses internal to the system and imperfections in the devices and systems. Likewise, the phrase “at least substantially coincident” refers to an orientation or movement that is intended, for all practical purposes to be on or near, for example, an axis or a plane as a convenient measure of the orientation or movement, but it is understood that this is just a convenient reference and that there can be variations due to stresses internal to the system and imperfections in the devices and systems.

FIGS. 1A-1I illustrate components of the system, according to some embodiments. As shown in FIG. 1A, the graft distribution systems **100** can have a central beam **101** with a central beam axis **105**, a graft distribution channel with an entry port **135** in fluid communication with a top exit port **140**, and a bottom exit port **141**. The central beam **101** can also have a proximal portion **111** having an end with the entry port **135**, a grafting portion **112** having the top exit port **140** and the bottom exit port **141**, and a distal portion (not shown). The central beam **101** can also be sized to have a transverse cross-section **110** having a maximum dimension ranging from 5 mm to 15 mm for placing the central beam **101** into an intervertebral space through an annular opening having a maximum lateral dimension ranging from 5 mm to 15 mm, the intervertebral space having a top vertebral plate and a bottom vertebral plate. The central beam **101** can also have a top surface **115** with a first top-lateral surface **117** and a second top-lateral surface **119**, a bottom surface **120** with a first bottom-lateral surface **122** and a second bottom-lateral surface **124**, a first side surface **125** with a first top-side surface **127** and a first bottom-side surface **129**, and a second side surface **130** with a second top-side surface **132** and a second bottom-side surface **134**.

In some embodiments, the central beam can have transverse cross-sectional lateral dimension ranging from about 5 mm to about 15 mm. In some embodiments, the vertical dimension of the central beam can range from about 4 mm to about 12 mm, about 5 mm to about 11 mm, about 6 mm to about 10 mm, and about 7 mm to about 9 mm, about 6 mm to about 8 mm, about 6 mm, or any range or amount therein in increments of 1 mm. In some embodiments, the lateral dimension of the central beam can range from about 5 mm to

about 15 mm, about 6 mm to about 14 mm, about 7 mm to about 13 mm, about 8 mm to about 12 mm, about 10 mm, or any range or amount therein in increments of 1 mm. In some embodiments, transverse cross-section of the central beam has an area with an effective diameter ranging from about 2 mm to about 20 mm, from about 3 mm to about 18 mm, from about 4 mm to about 16 mm, from about 5 mm to about 14 mm, from about 6 mm to about 12 mm, from about 7 mm to about 10 mm, or any range therein. In some embodiments, the low profile has an area with a diameter of 2 mm, 4 mm, 6 mm, 8 mm, 10 mm, 12 mm, 14 mm, 16 mm, 18 mm, or any range therein, including any increment of 1 mm in any such diameter or range therein. In some embodiments, the width (mm)×height (mm) of the central beam can be 9.0×5.0, 9.0×6.0, 9.0×7.0, 9.0×8.0, 9.0×9.0, and 9.0×10.0, or any deviation in dimension therein in increments of +/-0.1 mm. And, in some embodiments, the central beam can have a transverse cross-sectional lateral or vertical dimension that ranges from 6.5 mm to 14.0 mm.

As shown in FIGS. 1B and 10, the system **100** can also comprise a laterovertically-expanding frame **149** configured for operably contacting the central beam **101** to create a graft distribution system **100** in vivo, the frame **149** having a collapsed state **149c** with a transverse cross section **149ct** having a maximum dimension ranging from 5 mm to 15 mm for placing the frame **149** in the intervertebral space through the annular opening for expansion. Likewise, the frame **149** can also have an expanded state **149e** with a transverse cross section **149et** having a maximum dimension ranging from 6.5 mm to 18 mm for retaining the frame **149** in the intervertebral space, the expanded state operably contacting with the central beam **101** in the intervertebral space. The frame **149** can be defined as including a proximal portion **111** having an end, a grafting portion **112**, a distal portion (not shown) having an end, and a central frame axis **113** of the expanded state **149e**.

In some embodiments, the frame can have transverse cross-sectional lateral dimension in the collapsed state ranging from about 5 mm to about 15 mm. In some embodiments, the vertical dimension of the frame in the collapsed state can range from about 4 mm to about 12 mm, about 5 mm to about 11 mm, about 6 mm to about 10 mm, and about 7 mm to about 9 mm, about 6 mm to about 8 mm, about 6 mm, or any range or amount therein in increments of 1 mm. In some embodiments, the lateral dimension of the frame in the collapsed state can range from about 5 mm to about 15 mm, about 6 mm to about 14 mm, about 7 mm to about 13 mm, about 8 mm to about 12 mm, about 10 mm, or any range or amount therein in increments of 1 mm. In some embodiments, transverse cross-section of the frame in the collapsed state has an area with an effective diameter ranging from about 2 mm to about 20 mm, from about 3 mm to about 18 mm, from about 4 mm to about 16 mm, from about 5 mm to about 14 mm, from about 6 mm to about 12 mm, from about 7 mm to about 10 mm, or any range therein. In some embodiments, the low profile has an area with a diameter of 2 mm, 4 mm, 6 mm, 8 mm, 10 mm, 12 mm, 14 mm, 16 mm, 18 mm, or any range therein, including any increment of 1 mm in any such diameter or range therein. In some embodiments, the width (mm)×height (mm) of the frame in the collapsed state can be 9.0×5.0, 9.0×6.0, 9.0×7.0, 9.0×8.0, 9.0×9.0, and 9.0×10.0, or any deviation in dimension therein in increments of +/-0.1 mm. In some embodiments, the frame can have a transverse cross-sectional dimension, lateral or vertical in the expanded state ranging from 4.0 mm to 18 mm, from 5.0 mm to 19.0 mm, from 6.0 mm to 17.5 mm, from 7.0 mm to 17.0 mm, from 8.0 mm to 16.5 mm, from 9.0

mm to 16.0 mm, from 9.0 mm to 15.5 mm, from 6.5 mm to 15.5 mm, or any range or amount therein in increments of ± 0.1 mm.

The term “collapsed state” can be used to refer to a configuration of the frame in which the transverse cross-sectional area, or profile, is at least substantially at its minimum, and the term “expanded state” can be used to refer to a configuration of the frame that is expanded at least substantially beyond the collapsed state. In this context, a frame is expanded at least “substantially” beyond the collapsed state when a bone graft window of the frame has opened from the closed configuration by at least a 20% increase area of the bone graft window from the collapsed state. In some embodiments, the frame is expanded at least “substantially” beyond the collapsed state when a bone graft window of the frame has opened by at least a 15%, 20%, 25%, 30%, 35%, 40%, 45%, 50%, 60%, 70%, 80%, 90%, 100%, 150%, 200%, 250%, 300%, or more when compared to the bone graft window from the collapsed state. In some embodiments, the frame is expanded at least “substantially” beyond the collapsed state when a bone graft window of the frame has opened by at least 2 \times , 3 \times , 5 \times , 10 \times , 15 \times , 20 \times , or more when compared to the bone graft window from the collapsed state.

In some embodiments, the laterover vertically expandable frames are created in an expanded state. And the expanded state can include a state that is at least 30%, at least 40%, at least 50%, at least 60%, at least 70%, at least 80%, at least 90%, or at least 95% of the full expansion. The term “full expansion” can be used to refer to an extent of expansion upon which a connector element begins to fatigue, fail, or crack; or, in some embodiments, strain beyond 10%, 20%, or 30%.

The frame **149** can be configured to have a first top beam **150** including a proximal portion **111** having an end, a grafting portion **112**, and a distal portion (not shown) having an end, the first top beam **150** configured for contacting the first top-lateral surface **117** of the central beam and the first top-side surface **127** of the central beam **101** in the expanded state **149e**, the central axis of the first top beam at least substantially on (i) a top plane containing the central axis of the first top beam and the central axis of a second top beam and (ii) a first side plane containing the central axis of the first top beam and the central axis of a first bottom beam. Likewise the frame **149** can be configured to have a second top beam **160** including a proximal portion **111** having an end, a grafting portion **112** having an end, and a distal portion (not shown) having an end, the second top beam **160** configured for contacting the second top-lateral surface **119** of the central beam **101** and the second top-side surface **132** of the central beam **101** in the expanded state **149e**, the central axis of the second top beam at least substantially on (i) the top plane and (ii) a second side plane containing the central axis of the second top beam and the central axis of a second bottom beam. Likewise the frame **149** can be configured to have a first bottom beam **170** including a proximal portion **111** having an end, a grafting portion **112**, and a distal portion (not shown) having an end, the first bottom beam **170** configured for contacting the first bottom-lateral surface **122** of the central beam **101** and the first bottom-side surface **129** of the central beam **101** in the expanded state **149e**, the central axis of the first bottom beam at least substantially on (i) a bottom plane containing the central axis of the first bottom beam and the central axis of a second top beam and (ii) the first side plane. Likewise the frame **149** can be configured to have a second bottom beam **180** including a proximal portion **111** having an end, a grafting portion **112** having an end, and a distal region (not shown) having an end, the second bottom beam **180** configured for contacting the second bottom-lateral surface **124** of the cen-

tral beam **101** and the second bottom-side surface **134** of the central beam **101** in the expanded state **149e**, the central axis of the second bottom beam being at least substantially on (i) the bottom plane and (ii) a second side plane containing the central axis of the second bottom beam and the second top beam.

In some embodiments, the central axis of the first top beam **150** can be at least substantially parallel to the central beam axis **105**. Likewise the frame **149** can be configured to have a second top beam **160** including a proximal portion **111** having an end, a grafting portion **112** having an end, and a distal portion (not shown) having an end, the second top beam **160** configured for contacting the second top-lateral surface **119** of the central beam **101** and the second top-side surface **132** of the central beam **101** in the expanded state **149e**, the central axis of the second top beam **160** being at least substantially parallel to the central beam axis **105**. Likewise the frame **149** can be configured to have a first bottom beam **170** including a proximal portion **111** having an end, a grafting portion **112**, and a distal portion (not shown) having an end, the first bottom beam **170** configured for contacting the first bottom-lateral surface **122** of the central beam **101** and the first bottom-side surface **129** of the central beam **101** in the expanded state **149e**, the central axis of the first bottom beam **170** being at least substantially parallel to the central beam axis **105**. Likewise the frame **149** can be configured to have a second bottom beam **180** including a proximal portion **111** having an end, a grafting portion **112** having an end, and a distal region (not shown) having an end, the second bottom beam **180** configured for contacting the second bottom-lateral surface **124** of the central beam **101** and the second bottom-side surface **134** of the central beam **101** in the expanded state **149e**, the central axis of the second bottom beam **180** being at least substantially parallel to the central beam axis **105**.

As shown in FIG. 1D, the systems provided herein have the layered effect from the frame on the central beam that provides an additive dimension, both laterally and vertically. The added dimension allows for a low profile entry of the system into the intervertebral disc space, a wide lateral profile after expansion in vivo to avoid backout, as well as a sleeve for safe insertion of the central beam between the top endplate and bottom endplate in the intervertebral space. In some embodiments, the first top beam, second top beam, first bottom beam, and second bottom beam can each have a transverse cross-sectional wall thickness adding to the respective central beam dimension, the thickness ranging from about 0.5 mm to about 5.0 mm, from about 0.75 mm to about 4.75 mm, from about 1.0 mm to about 4.5 mm, from about 1.25 mm to about 4.25 mm, from about 1.5 mm to about 4.0 mm, from about 1.75 mm to about 3.75 mm, from about 2.0 mm to about 3.5 mm, from about 2.25 mm to about 3.25 mm, or any range therein in increments of 0.05 mm. In some embodiments, the first top beam, second top beam, first bottom beam, and second bottom beam can each have a transverse cross-sectional wall thickness adding to the respective central beam dimension, the thickness ranging from about 1.5 mm to about 2.5 mm, including 1.5, 1.75, 2.0, 2.25, 2.5, or an amount therein in increments of 0.05 mm.

The beams of the laterover vertically-expanding frame **149** can be operably connected through connector elements. As such, the frame **149** can include a plurality of proximal top connector elements **191** configured to expandably connect the proximal portion **111** of the first top beam **150** to the proximal portion **111** of the second top beam **160**, the expanding consisting of a flexing at least substantially on a top plane containing the central axis of the first top beam **150** and the central axis of the second top beam **160**. Likewise the frame

11

149 can be configured to have a plurality of distal top connector elements (not shown) configured to expandably connect the distal portion of the first top beam 150 to the distal portion of the second top beam 160, the expanding consisting of a flexing at least substantially on the top plane.

Likewise the frame 149 can be configured to have a plurality of proximal bottom connector elements 193 configured to expandably connect the proximal portion 111 of the first bottom beam 170 to the proximal portion 111 of the second bottom beam 180, the expanding consisting of a flexing at least substantially on a bottom plane containing the central axis of the first bottom beam 170 and the central axis of the second bottom beam 180. Likewise the frame 149 can be configured to have a plurality of distal bottom connector elements (not shown) configured to expandably connect the distal portion of the first bottom beam 170 to the distal portion of the second bottom beam 180, the expanding consisting of a flexing at least substantially on the bottom plane.

Likewise the frame 149 can be configured to have a plurality of proximal first side connector elements 195 configured to expandably connect the proximal portion 111 of the first top beam 150 to the proximal portion 111 of the first bottom beam 170, the expanding consisting of a flexing at least substantially on a first side plane containing the central axis of the first top beam 150 and the central axis of the first bottom beam 170; a plurality of distal first side connector elements (not shown) configured to expandably connect the distal portion of the first top beam 150 to the distal portion of the first bottom beam 170, the expanding consisting of a flexing at least substantially on the first side plane. Likewise the frame 149 can be configured to have a plurality of proximal second side connector elements 197 configured to expandably connect the proximal portion 111 of the second top beam 160 to the proximal portion 111 of the second bottom beam 170, the expanding consisting of a flexing at least substantially on a second side plane containing the central axis of the second top beam 160 and the central axis of the second bottom beam 180; a plurality of distal second side connector elements (not shown) configured to expandably connect the distal portion of the second top beam 160 to the distal portion of the second bottom beam 180, the expanding consisting of a flexing at least substantially on the second side plane.

In some embodiments, each plurality of proximal connector elements can be configured as proximal struts in an at least substantially parallel alignment in the expanded state and the collapsed state; and, each plurality distal connector elements are distal struts can be configured in an at least substantially parallel alignment in the expanded state and the collapsed state. As such, the proximal top struts can be configured monolithically integral to the first top beam and the second top beam and adapted to flex toward the distal top struts during collapse; and, the distal top struts can be configured monolithically integral to the first top beam and the second top beam and adapted to flex toward the proximal top struts during collapse. Likewise, the proximal bottom struts can be configured monolithically integral to the first bottom beam and the second bottom beam and adapted to flex toward the distal bottom struts during collapse; and, the distal bottom struts can be configured monolithically integral to the first bottom beam and the second bottom beam and adapted to flex toward the proximal bottom struts during collapse. Likewise, the proximal first side struts can be configured monolithically integral to the first top beam and the first bottom beam and adapted to flex toward the distal first side struts during collapse; and, the distal first side struts can be configured monolithically integral to the first top beam and the first bottom

12

beam and adapted to flex toward the proximal first side struts during collapse. Likewise, the proximal second side struts can be configured monolithically integral to the second top beam and the second bottom beam and adapted to flex toward the distal second side struts during collapse; and, the distal second side struts can be configured monolithically integral to the second top beam and the second bottom beam and adapted to flex toward the proximal second side struts during collapse.

As shown in FIG. 1D, the frame 149 can be configured for slidably engaging with the central beam 101 in vivo following placement of the central beam 101 in the intervertebral space through the annular opening, the slidably engaging including translating the central beam 101 into the frame 149 from the proximal end 11 of the frame 149 toward the distal end of the frame 149 in vivo; the translating including keeping the central beam axis 105 at least substantially coincident with the central frame axis 113 during the translating to create the graft distribution system 100 in vivo through the annular opening. The system 100 can also be configured to form a top graft-slab depth 199t between the top surface 115 of the central beam 101 and the top vertebral endplate; and, a bottom graft-slab depth 199b (not shown) between the bottom surface 120 of the central beam 101 and the bottom vertebral endplate in vivo. And, in some embodiments, the transverse cross-section 110 of the system 100 in vivo is greater than the maximum lateral dimension of the annular opening to avoid backout.

One of skill will appreciate that the central beam can have any configuration that would be operable with the teachings provided herein. In some embodiments, criteria for a suitable central beam may include a combination of a material and configuration that provides a suitable stiffness. In some embodiments, the central beam can comprise an I-beam. An example of an I-beam configuration and a complementary laterovertically expandable cage are shown in FIGS. 1E and 1F.

One of skill will further appreciate that the central beam can have any one or any combination of graft port configurations that would be operable with the teachings provided herein. In some embodiments, criteria for a suitable graft port configuration may include a combination of port size, number of ports, and placement of ports. In some embodiments, the central beam can comprise a side graft port.

One of skill will further appreciate that the connector elements can vary in design but should meet the constraints as taught herein. In some embodiments, for example each of the connector elements 191, 193, 195, 197 can have a cross-sectional aspect ratio of longitudinal thickness to transverse thickness ranging from 1:2 to 1:8. A section of a connector element is shown in FIG. 1G.

As such, the systems can also include an improved, low-profile, intervertebral disc cage that expands bidirectionally. Consistent with the teachings herein, the cages offer several improvements to the art that include, for example, preventing the cage from backing out of the annulus fibrosis after expansion in an intervertebral disc space. As such, the terms “cage,” “scaffold” and “scaffolding”, for example, can be used interchangeably with “laterovertically expandable frame”, “expandable frame”, or “frame”, in some embodiments. The cages have the ability to at least (i) laterally expand within the intervertebral space to avoid backout of the device through the annulotomy, (ii) vertically expand for distraction of the intervertebral space, (iii) provide additional space within the device in the annulus for the introduction of graft materials; (iv) maintain a large, footprint to distribute load over a larger area against the endplate, for example, by not contracting in

length to expand in height and/or width; and, (v) insert into the annulus in a minimally-invasive manner using only a unilateral approach.

FIGS. 2A-2F illustrate a method of using a bidirectionally-expandable cage, according to some embodiments. As shown in FIGS. 2A-2B, an annulus 205 is prepared with an annulotomy serving as a single point of entry 210 and an intervertebral space 215 for insertion of a bidirectionally expandable cage system 250. As shown in FIGS. 2C-2F, the system 250 has a cage 255 having a proximal end 256, a distal end 257, and a lumen 258 that communicates with the intervertebral space 215 through an expandable/collapsible bone graft window 259; a shim core 260 having a tapered nose 262 at the distal end of the shim core 260; a releasably attachable rail beam 265; a pusher 270 that slidably translates over the shim core 260 and the rail beam 265; a trial shim 275 having a shoulder 277 and slidably translating over the rail beam 265 and shim core 260 into the lumen 258 of the cage 255, and a permanent shim 280 having a shoulder 282 and slidably translating over the rail beam 265 and shim core 260 into the lumen 258 of the cage 255.

The procedure for implanting the cage 255 begins in FIG. 2A, including inserting a cannula (not shown) with a bullet-nosed obturator through the single point of entry 210 and inside the intervertebral disc space 215 until contacting the opposing wall of the annulus 205. The cannula (not shown) depth is used to select the desired length of the cage 255. The shim core 260 is loaded with bone graft material and the rail beam 265 is releasably attached to the shim core 260. The cage 255 is loaded onto the rail beam 265 and pushed onto the shim core 260 and into the cannula (not shown) using the pusher 270 until the distal end 257 of the cage 255 contacts the back of the tapered nose 262 of the shim core 260 as shown in FIG. 2A. The assembly of the shim core 260 and the cage 255 are inserted into the intervertebral space 215, and the cannula (not shown) is removed as shown in FIG. 2B. The lumen 258 of the cage 255 is loaded with bone graft material, and the trial shim 275 is slidably translated over the rail beam 265 and the shim core 260 into the lumen 258 of the cage 255 as shown in FIG. 2C. A variety of sizes of the trial shim 275 can be tested until the largest trial shim 275 that will fit is found, or until the trial shim having the desired vertical and lateral dimensions for expansion is used, in order to lateroververtically expand the cage 255 as desired. The trial shim 275 is then removed, and the lumen 258 of the cage 255 is again filled with bone graft material with the shim core 260 remaining in place as shown in FIG. 2D. The permanent shim 280 is then slidably translated along the rail beam 265 and the shim core 260 into the intervertebral space 215 using the pusher 270 until the distal end 257 of the cage 255 contacts the back of the tapered nose 262 of the shim core 260 to maintain the desired lateroververtical expansion of the cage 255 as shown in FIG. 2E. The rail beam 265 is then disconnected from the shim core 260 as shown in FIG. 2F.

It should be appreciated that the annulotomy can have nearly any dimension considered desirable to one of skill in the art. The annulotomy can have a vertical dimension, for example, that is the distance between a top vertebral plate and a bottom vertebral plate, the top vertebral plate and the bottom vertebral plate defining the upper and lower borders of the intervertebral disc space. In some embodiments, the vertical dimension can range from about 4 mm to about 12 mm, about 5 mm to about 11 mm, about 6 mm to about 10 mm, and about 7 mm to about 9 mm, about 6 mm to about 8 mm, about 6 mm, or any range or amount therein in increments of 1 mm. In some embodiments, the lateral dimension of the single point of entry can range from about 5 mm to about 15 mm, about 6

mm to about 14 mm, about 7 mm to about 13 mm, about 8 mm to about 12 mm, about 10 mm, or any range or amount therein in increments of 1 mm. In some embodiments, the single point of entry has an area with a diameter ranging from about 2 mm to about 20 mm, from about 3 mm to about 18 mm, from about 4 mm to about 16 mm, from about 5 mm to about 14 mm, from about 6 mm to about 12 mm, from about 7 mm to about 10 mm, or any range therein. In some embodiments, the low profile has an area with a diameter of 2 mm, 4 mm, 6 mm, 8 mm, 10 mm, 12 mm, 14 mm, 16 mm, 18 mm, or any range therein, including any increment of 1 mm in any such diameter or range therein. The low profile dimensions of the cages taught herein are designed to fit within these dimensions.

One of skill will also appreciate that there are several methods and devices that could be used to expand the cage. In some embodiments, the expanding includes using a means for (i) lateroververtically expanding the cage and (ii) creating a convex surface that at least substantially complements the concavity of a surface of a vertebral endplate that contacts the pair of top beams or the pair of bottom beams.

One of skill will also appreciate a method that distracts the intervertebral space and laterally expands the cage to avoid back-out. As such, in some embodiments, the expanding includes introducing a lateroververtical expansion member into the intervertebral space through the single point of entry and into the cage, the lateroververtical expansion member configured to provide a vertical force through the cage and into the top vertical endplate and bottom vertical endplate to distract the intervertebral space; and, a lateral force on the first side wall and the second side wall to expand the cage to a width that is greater than the lateral dimension of the single point of entry to prevent the bidirectionally-expandable cage from backing out of the annulus fibrosis after the expanding.

One of skill will also appreciate having a method for passing bone grafting material into the intervertebral space. As such, the lateroververtical expansion member can include a port for introducing the grafting material into the intervertebral space. The methods and systems provided herein include the use of bone graft materials known to one of skill. Materials which may be placed or injected into the intervertebral space include solid or semi-solid grafting materials, bone from removed from patient's facet, an iliac crest harvest from the patient, and bone graft extenders such as hydroxyapatite, demineralized bone matrix, and bone morphogenic protein. Examples of solid or semi-solid grafting material components include solid fibrous collagen or other suitable hard hydrophilic biocompatible material. Some materials may also include swelling for further vertical expansion of the intervertebral disc space.

One of skill will also appreciate having a method for retaining the lateroververtical expansion member in the cage. As such, the introducing can include engaging a ratchet mechanism comprising a protuberance on the lateroververtical expansion member that engages with a strut of the cage to prevent the cage from backing out of the annulus fibrosis after the expanding. The ratchet mechanism can be, for example, similar to a zip-tie ratchet mechanism having a gear component and a pawl component. In some embodiments, the cage has the gear component, for example, including the struts; and, the lateroververtical expansion member is a shim device having the pawl component, for example, a projection that can angle toward the proximal end of the expansion member or away from the direction of insertion of the shim device. In some embodiments, the cage has the pawl component, for example, including the struts; and, the lateroververtical expansion member is a shim device having the gear component, for example, a series of projections. In some embodiments, a projection can

angle from about 5° to about 75° toward the proximal end of the expansion member or away from the direction of insertion of the shim device.

One of skill will also appreciate having a method of designing the shape of the cage upon expansion. As such, in some embodiments, the expanding includes selecting a shim configured to create a convex surface on the top surface of the top wall to at least substantially complement the concavity of the respective top vertebral plate, and/or the bottom surface of the bottom wall to at least substantially complement the concavity of the respective bottom vertebral plate. In some embodiments, the expanding includes selecting a shim configured to vertically expand the distal end of the cage more than the proximal end of the cage. And, in some embodiments, the expanding includes selecting a shim configured to laterally expand the distal end of the cage more than the proximal end of the cage.

FIGS. 3A-3D illustrate collapsed and expanded views of a bidirectionally-expandable cage for fusing an intervertebral disc space, according to some embodiments. FIGS. 3A and 3C show an expanded configuration, and FIGS. 3B and 3D show a collapsed configuration. The cage 300 can comprise at least 4 walls 302, 304, 306, 308 that form a cylinder having a long axis 309, the at least 4 walls 302, 304, 306, 308 including a top wall 302 forming a top plane and having a top surface with protuberances (not shown) adapted to contact the top vertebral plate (not shown); a bottom wall 304 forming a bottom plane and having a bottom surface with protuberances (not shown) adapted to contact the bottom vertebral plate (not shown); a first side wall 306 forming a first side wall plane; and, a second side wall 308 forming a second side wall plane. In these embodiments, each of the walls 302, 304, 306, 308 can have at least 2 longitudinal beams, such that a rectangular cylinder can have a total of 4 longitudinal beams 312, 314, 316, 318; and, a plurality of struts 333 that (i) stack in the collapsed state of the cage 300, as shown in FIGS. 3B and 3D, to minimize void space in their respective wall for a low profile entry of the cage 300 both vertically and laterally into a single point of entry (not shown) into an intervertebral disc space (not shown) and (ii) deflect upon expansion to separate the at least 2 longitudinal beams of the total of 4 longitudinal beams 312, 314, 316, 318 in the rectangular cylinder in their respective wall 302, 304, 306, 308. In addition, the cage 300 can be configured to expand laterally in the intervertebral space (not shown) to a size greater than a lateral dimension of the single point of entry (not shown) to prevent the bidirectionally-expandable cage 300 from backing out of the annulus fibrosis (not shown) after the expanding shown in FIGS. 3A and 3C.

It should be appreciated that the collapsed configuration includes the design of a low profile entry through the annulus fibrosis to allow for a minimally-invasive procedure. In order to facilitate the use of a minimally-invasive procedure, the low profile entry of the collapsed configuration should be a substantially small area of entry having a diameter ranging, for example, from about 5 mm to about 12 mm for the single point of entry through the annulus fibrosis. In some embodiments, the low profile has an area with a diameter ranging from about 2 mm to about 20 mm, from about 3 mm to about 18 mm, from about 4 mm to about 16 mm, from about 5 mm to about 14 mm, from about 6 mm to about 12 mm, from about 7 mm to about 10 mm, or any range therein. In some embodiments, the low profile has an area with a diameter of 2 mm, 4 mm, 6 mm, 8 mm, 10 mm, 12 mm, 14 mm, 16 mm, 18 mm, or any range therein, including any increment of 1 mm in any such diameter or range therein.

One of skill will appreciate that a variety of strut configurations may be contemplated to minimize void space for the low profile entry of the cage into the intervertebral space. In some embodiments, each wall of the cage has a series of v-shaped struts 333 that (i) stack in a closed-complementary configuration 344 in the collapsed state to minimize void space in their respective wall for the low profile entry of the cage both vertically and laterally into the intervertebral space, and (ii) deflect upon expansion in a plane that is at least substantially parallel to the plane of their respective wall to an open-complementary configuration 355 to separate the at least 2 longitudinal beams of the total of 4 longitudinal beams 312, 314, 316, 318 in the rectangular cylinder in their respective wall and open a bone graft window 366 to pass a bone graft material into the intervertebral space in the expanded configuration. In some embodiments, the cage 300 is configured to accommodate the lateral dimension of the single point of entry ranging from about 5 mm to about 15 mm.

The v-shaped struts can be “V” shaped slots projected through each of the cage walls starting at a distance of 2 mm (0.5-4) from each corner of the cage to effectively render the “V” shaped struts in the mid region of the wall faces, in which the struts can be fabricated as continuous with L shaped beams on the corners. The slots can be cut such that they are projected perpendicular to the faces or angled distally from the outside of the cage to the inside of the cage. The distally angled projection can facilitate insertion of the shims taught herein. And, the proximal faces of the corners of the beams can also have inward, distally angled chamfers to facilitate insertion of the shims taught herein. The struts can be uniform in thickness in the proximal-distal direction. In some embodiments, the struts range from about 0.2 mm to about 1.0 mm, from about 0.3 mm to about 0.9 mm, from about 0.4 mm to about 0.8 mm, from about 0.5 mm to about 0.7 mm in thickness, or any range therein in increments of about 0.1 mm. The vertex of the “V” strut can trace along the center axis of the each of the side faces and can be radiused to dimension of 0.031" (0.005-0.062"), in some embodiments, to prevent stress cracking. Moreover, the shape of the strut or the slot projections can also be C, U, or W, in some embodiments. The struts can be 4 times thicker in the direction perpendicular to the long axis of the cage than in the direction of the long axis of the cage. In some embodiments, this thickness ratio can range from about 2× to about 8×, from about 3× to about 7×, from about 4× to about 6×, about 5×, or any range therein in increments of 1×. This thickness can help maintain a high structural stiffness and strength in the direction perpendicular to the proximal-distal axis so that the transverse cross section (perpendicular to the proximal-distal axis) shape is maintained during and after insertion of the cage into the intervertebral disc space.

In some embodiments, the angle of each strut can range from about 140°-170° as measured at the vertex in the non-stressed state. In these embodiments, the angle facilitates flexion of the legs of each strut towards each other upon moderate inward pressure to collapse the cage for insertion into the disc space. Furthermore the angled strut lies in a plane at least substantially parallel to the plane of its respective wall, and in some embodiments to the long axis of the cage, so that the flexion does not alter the side wall thickness. This helps to maintain the low profile for insertion while maximizing the lumen size. This geometry combined with the solid beams on the corners helps ensure that the implant has a minimal change in length, less than 15% reduction in length as measured along the long axis, when expanded more than 20% vertically and/or horizontally. As such, the top and bot-

tom of the cage that support the vertebra remain at least substantially constant in length regardless of expansion.

In some embodiments, the cage **300** has v-shaped struts **333** and a bone graft window **366** that (i) complements the v-shaped struts **333** in the collapsed configuration and (ii) opens upon expansion to pass a bone graft material into the intervertebral space in the open-complementary configuration **355**, which can also be referred to as an expanded configuration. And, in some embodiments, the cage **300** has a proximal region **311**, a proximal end **322**, a distal region **388**, a distal end **399**, and at least one of the at least 4 walls **302**, **304**, **306**, **308** having a first series of v-shaped struts **333** that are configured to stack in a closed-complementary configuration **344** in the collapsed state to minimize void space for the low profile entry of the cage **300** into the intervertebral space; and, deflect upon expansion to an open-complementary configuration **355** to separate the at least 2 longitudinal beams of the total of 4 longitudinal beams **312**, **314**, **316**, **318** in the rectangular cylinder in their respective wall and open a bone graft window **366** adapted to pass a bone graft material into the intervertebral space in the expanded configuration; wherein, the first series of v-shaped struts **333F** is located in the proximal region of the cage, the vertices of the first series of v-shaped struts **333F** pointing away from the proximal end **322** of the cage **300** and toward the distal end **399** of the cage **300**. In some embodiments, the cage **300** can further comprise a second series of v-shaped struts **333S** that stack in a closed-complementary configuration **344** in the collapsed state to minimize void space for the low profile entry of the cage **300** into the intervertebral space; and, deflect upon expansion to an open-complementary configuration **355** to separate the at least 2 longitudinal beams of the total of 4 longitudinal beams **312**, **314**, **316**, **318** in the rectangular cylinder in their respective wall and open a bone graft window **366** adapted to pass a bone graft material into the intervertebral space in the expanded configuration; wherein, the second series of v-shaped struts **333S** is located in the distal region **388** of the cage **300**, the vertices of the second series of v-shaped struts **333S** pointing away from the distal end **399** of the cage **300** and toward the proximal end **322** of the cage **300**. In such embodiments, the strut configuration can result in the expansion of the first series of v-shaped struts **333F** and the second series of v-shaped struts **333S** creating a bone graft window **366** that opens to the bow-tie configuration shown in FIGS. **3A** and **3C**.

One of skill will also appreciate that the cage design provides flexibility in the relative amounts of lateral expansion and vertical expansion, as well as the relative amounts of expansion proximally and distally across the cage in either the lateral or vertical expansions. As such, in some embodiments, the cage is configured such that the ratio of the amount of lateral expansion to the amount of vertical expansion is variable. And, in some embodiments, the cage is configured such that the ratio of the amount of proximal expansion to the amount of distal expansion is variable for lateral expansion or vertical expansion.

FIGS. **4A** and **4B** illustrate collapsed and expanded views of a bidirectionally-expandable cage having a bone graft window on each wall for fusing an intervertebral disc space, according to some embodiments. FIG. **4A** shows the cage **400** in the collapsed configuration for a low-profile entry **405** into to single point of entry into an intervertebral disc space, and FIG. **4B** shows the cage **400** in the expanded configuration to distract the intervertebral disc space and avoid back-out of the cage through the single point of entry after the expansion. As shown, each wall contains a bone graft window **466** for passing bone graft material into the intervertebral disc space.

FIGS. **5A-5D** illustrate system for fusing an intervertebral disc space, according to some embodiments. As shown, the system **550** has a cage **555** having an expandable/collapsible bone graft window **566**; a shim core **560** having a tapered nose **562** at the distal end of the shim core **560** and a bone graft window **566**; a releasably attachable rail beam **565**; a pusher (not shown) that slidably translates over the shim core **560** and the rail beam **565**; a trial shim **575** having a shoulder **577** and slidably translating over the rail beam **565** and shim core **560** into the cage **555**, and a permanent shim **580** having a shoulder **582** and slidably translating over the rail beam **565** and shim core **560** into the cage **555**. The system can comprise a bidirectionally-expandable cage having at least 4 walls that form a cylinder having a long axis. The at least 4 walls can include, for example, a top wall forming a top plane and having a top surface with protuberances adapted to contact the top vertebral plate; a bottom wall forming a bottom plane and having a bottom surface with protuberances adapted to contact the bottom vertebral plate; and, a first side wall forming a first side wall plane, and a second side wall forming a second side wall plane. Each of the walls can have at least 2 longitudinal beams; and, a plurality of struts that (i) stack in the collapsed state to minimize void space in their respective wall for a low profile entry of the cage both vertically and laterally into a single point of entry into an intervertebral disc; and, (ii) deflect upon expansion to separate the at least 2 longitudinal beams in their respective wall. In some embodiments, the cage can be configured to expand laterally in the intervertebral space to a size greater than a lateral dimension of the single point of entry to prevent the bidirectionally-expandable cage from backing out of the annulus fibrosis after the expanding. Moreover, the system can include a laterovertical expansion member configured to induce the laterally expanding and the vertically expanding of the cage; and, a core configured to guide the laterovertical expansion member into the cage to induce the laterally expanding and the vertically expanding of the cage.

One of skill will appreciate that the laterovertical expansion member can also be configured to slidably engage with the core to translationally enter the cage in along the long axis of the cage. In some embodiments, the lateral expansion can occur concurrent with the vertical expansion and, in some embodiments, the lateral expansion can occur prior to the vertical expansion, for example, to reduce frictional stress on the cage during the lateral expansion. A two stage shim, for example, can be used. A first stage shim can be inserted to expand the cage laterally before inserting a second stage shim to expand the cage vertically. In some embodiments, the second stage shim can slidably translate along the first stage shim. The shim can be made of any material considered desirable to one of skill, for example, a metal or a polymer. In some embodiments, the shim can comprise a non-resorbable polymer material, an inorganic material, a metal, an alloy, or bone.

One of skill will appreciate that a system can include all or any combination of the above. As such, the teachings also include system for fusing an intervertebral disc space, the system comprising a bidirectionally-expandable cage having a proximal region, a proximal end, a distal region, a distal end, and at least 4 walls, the cage fabricated as a continuous single piece. In these embodiments, the at least 4 walls form a cylinder having a long axis and include a top wall forming a top plane and having a top surface with protuberances adapted to contact the top vertebral plate; a bottom wall forming a bottom plane and having a bottom surface with protuberances adapted to contact the bottom vertebral plate; and, a first side wall forming a first side wall plane, and a

second side wall forming a second side wall plane. Each of the walls can have at least 2 longitudinal beams and a plurality of struts.

At least one of the walls can have a first series of v-shaped struts that are configured to stack in a closed-complementary configuration in the collapsed state to minimize void space for a low profile entry of the cage through a single point of entry into an intervertebral disc space; and, deflect upon expansion to an open-complementary configuration to separate the at least 2 longitudinal beams in their respective wall and open a bone graft window adapted to pass a bone graft material into the intervertebral space in the expanded configuration. The first series of v-shaped struts can be located in the proximal region of the cage, the vertices of the first series of v-shaped struts pointing away from the proximal end of the cage and toward the distal end of the cage; and, the cage can be configured to expand laterally in the intervertebral space to a size greater than a lateral dimension of the single point of entry to prevent the bidirectionally-expandable cage from backing out of the annulus fibrosis after the expanding. A laterovertical expansion member can be configured to induce the laterally expanding and the vertically expanding of the cage; and, a core can be configured to guide the laterovertical expansion member into the proximal end of the cage, and along the long axis of the cage, to expand the cage laterally and vertically. Moreover, the laterovertical expansion member can slidably engage with the core to translationally enter the cage along the long axis of the cage.

One of skill will appreciate that the systems and system components can be manufactured using any method known to one of skill in the manufacture of such intricate metal and/or polymeric components. For example, the cage can be fabricated in a partially expanded state or a fully expanded state. Moreover, the cage can be manufactured to have no internal stress or strain in the partially or fully expanded state when no external loading is applied.

The system components can comprise any suitable material, or any combination of materials, known to one of skill. For example, all components can be metal, all components can be plastic, or the components can be a combination of metal and plastic. One of skill will appreciate that the cages can have performance characteristics that are near that of a bone structure, in some embodiments, such that the scaffoldings are not too stiff or hard, resulting in a localized loading issue in which the scaffolding puts too much pressure on native bone tissue, and likewise such that the scaffoldings are too flexible or soft, resulting in a localized loading issue in which the bone tissue puts too much pressure on the scaffolding. A radio-opaque material can be employed to facilitate identifying the location and position of the scaffolding in the spinal disc space. Examples of such materials can include, but are not limited to, platinum, tungsten, iridium, gold, or bismuth.

One of skill can select materials on the basis of desired material performance characteristics. For example, one of skill will look to performance characteristics that can include static compression loading, dynamic compression loading, static torsion loading, dynamic torsion loading, static shear testing, dynamic shear testing, expulsion testing, and subsidence testing. The parameters for upper and lower limits of performance for these characteristics can fall within the range of existing such spinal devices that bear the same or similar environmental conditions during use. For example, a desired static compression loading can be approximately 5000N. A desired dynamic compression loading can have an asymptotic load level of 3000N at 5×10^6 cycles or ≥ 1500 N at 10×10^6 cycles. The desired load level can range, for example, from

about 1.0x to about 2.0x, from about 1.25x to about 1.75x, or any range therein in increments of 0.1x, the vertebral body compression strength. Examples of standard procedures used to test such performance characteristics include ASTM F2077 and ASTM F2624.

Examples of suitable materials can include non-reinforced polymers, carbon-reinforced polymer composites, PEEK (polyether ketone) and PEEK composites, polyetherimide (ULTEM), polyimide, polyamide or carbon fiber. Other examples include metals and alloys comprising any one or more components including, but not limited to, shape-memory alloys, nickel, titanium, titanium alloys, cobalt chrome alloys, stainless steel, ceramics and combinations thereof. In some embodiments, the components are all titanium or titanium alloy; all PEEK; or a combination of titanium or titanium alloy and PEEK. In some embodiments, the cage comprises titanium or titanium alloy, and the shim comprises PEEK. In some embodiments, the scaffolding can comprise a metal frame and cover made of PEEK or ULTEM. Examples of titanium alloys can include alloys of titanium, aluminum, and vanadium, such as Ti_6Al_4V in some embodiments.

In some embodiments, the cage can be fabricated from strong and ductile polymers having a tensile modulus of about 400,000 psi or more, and a tensile strength of about 14,000 psi or more. Such polymers may also have the ability to strain more than 4% to break, and perhaps at least 20% to break in some embodiments. The materials can be stiffened by being filled with glass fibers or carbon fibers in some embodiments.

Bone ingrowth is desirable in many embodiments. As such, the scaffolding can comprise materials that contain holes or slots to allow for such bone ingrowth. Consistently, the scaffoldings can be coated with hydroxyapatite, or other bone conducting surface, for example, bone morphogenic protein, to facilitate bone ingrowth. Moreover, the surfaces of the scaffoldings can be formed as rough surfaces with protuberances, insets, or projections of any type known to one of skill, such as teeth or pyramids, for example, to grip vertebral endplates, avoid migration of the scaffolding, and encourage engagement with bone ingrowth.

The methods and systems provided herein include the use of bone graft materials known to one of skill. Materials which may be placed or injected into the intervertebral space include solid or semi-solid grafting materials, bone from removed from patient's facet, an iliac crest harvest from the patient, and bone graft extenders such as hydroxyapatite, demineralized bone matrix, and bone morphogenic protein. Examples of solid or semi-solid grafting material components include solid fibrous collagen or other suitable hard hydrophilic biocompatible material. Some materials may also include swelling for further vertical expansion of the intervertebral disc space.

The systems taught herein can be provided to the art in the form of kits. A kit can contain, for example, a cage, a vertical expansion member, and a bone graft material. In some embodiments, the kit will contain an instruction for use. The vertical expansion member can be any vertical expansion mechanism or means taught herein. For example, the vertical expansion member can be a shim. In some embodiments, the kit includes a graft-injection shim for temporarily distracting the intervertebral space, the graft-injection shim having a port for receiving and distributing the bone graft material in the intervertebral space. In these embodiments, the graft-injection shim can remain as a permanent shim or be removed and replaced with a permanent shim.

FIG. 6 is a flowchart of a method of using a bidirectionally-expandable cage, according to some embodiments. The

methods can include creating **605** a single point of entry into an intervertebral disc, the intervertebral disc having a nucleus pulposus surrounded by an annulus fibrosis, and the single point of entry having a lateral dimension created through the annulus fibrosis. The methods can also include removing **615** the nucleus pulposus from within the intervertebral through the single point of entry, leaving an intervertebral space for expansion of a bidirectionally-expandable cage within the annulus fibrosis, the intervertebral space having a top vertebral plate and a bottom vertebral plate. The methods can also include inserting **625** a bidirectionally-expandable cage through the single point of entry into the intervertebral space. Moreover, the methods can include expanding **635** the cage in the intervertebral space both laterally and vertically, adding **645** a grafting material to the intervertebral space through the single point of entry, and inserting **665** a permanent shim into the cage.

One of skill will appreciate having the ability to control the amounts of vertical expansion and lateral expansion of the cage to accommodate a variety of applications, for example, to accommodate a variety annulotomy dimensions used for the single point of entry. As such, in some embodiments, the expanding **635** includes selecting **655** an amount of lateral expansion independent of an amount of vertical expansion. The lateral expanding of the cage can be selected, for example, to exceed the lateral dimension of the single point of entry through an annulotomy by a desired amount to avoid, or prevent, the cage from backing out of the intervertebral space after expansion.

As such, methods of fusing an intervertebral space are provided herein using any of the graft distribution systems taught herein. The methods can include creating a single point of entry into an intervertebral disc, the intervertebral disc having a nucleus pulposus surrounded by an annulus fibrosis, and the single point of entry having the maximum lateral dimension created through the annulus fibrosis. The methods can also include removing the nucleus pulposus from within the intervertebral disc through the single point of entry, leaving the intervertebral space for expansion of the graft distribution system within the annulus fibrosis, the intervertebral space having the top vertebral plate and the bottom vertebral plate. The methods can also include inserting the laterover vertically expanding frame in the collapsed state through the single point of entry into the intervertebral space; and, inserting the central beam into the frame to form the graft distribution system. Moreover, the methods can also include adding a grafting material to the intervertebral space through the entry port.

FIGS. 7A-7F illustrate some additional features of graft distribution systems, according to some embodiments. The graft distribution systems **700** provided herein have at least a top exit port **740** and a bottom exit port **741** in the grafting portion of the central beam **701**, but they can also contain side ports **742, 743**, such that there at least 4 graft distribution ports in some embodiments. In some embodiments, the central beam **701** further comprises a first side graft port **742** and a second side graft port **743**, in addition to a locking clip **702** at the proximal end of the central beam. In some embodiments, the laterover vertically-expanding frame **749** can be a monolithically integral frame, optionally having a "bullet nose" **703** at the distal end of the frame for safe position of the cage against the anterior inner annulus in vivo, and adapted to open a graft distribution window **788** on at least the top and bottom sides, as well as the first side and second side in some embodiments containing side ports, upon expansion of the connector elements to facilitate graft distribution within the intervertebral space.

The distal end of the frame **749** can be configured to have a laterover vertically operable connection with a guide plate **707** that restricts the first top beam, the first bottom beam, the second top beam, and the second bottom beam to laterover vertical movement relative to the guide plate when converting the frame from the collapsed state to the expanded state in vivo. And, in some embodiments, the laterover vertically-expandable frame has a lumen, and the guide plate has a luminal side with a connector **708** for reversibly receiving a guide wire for inserting the laterover vertically-expandable frame into the intervertebral space. In some embodiments, the frame has a chamfer inside the proximal end of the frame beams to facilitate insertion of central beam. And, in many embodiments, the frames have means for creating friction between the vertebral endplates and the frame, such as protuberances, for example cleat-type structures **704**, to further avoid backout.

As can be seen in at least FIG. 7, the bone graft distribution systems provided herein include bone graft windows defined by the connector elements, the bone graft windows opening upon expansion of the laterover vertically expanding frame. In some embodiments, the method further comprises opening a bone graft window, wherein the connector elements include v-shaped struts that (i) stack either proximally or distally in a closed-complementary configuration in the collapsed state to minimize void space for a low profile entry of the system both vertically and laterally into the intervertebral space, and (ii) deflect upon expansion to open the bone graft window.

It should be appreciated that the bone graft distribution systems provided herein also allow for independent expansion laterally and vertically by expanding in steps. In some embodiments, the expanding includes selecting an amount of lateral expansion independent of an amount of vertical expansion. And, in some embodiments, the lateral expansion exceeds the width of the annular opening that is the single point of entry into the intervertebral space. For example, the lateral dimension of the single point of entry can range from about 5 mm to about 15 mm in some embodiments. As such, in some embodiments, the expanding includes expanding the laterover vertically expanding frame laterally to a width that exceeds the width of the single point of entry; and, inserting the central beam to expand the laterover vertically expanding frame vertically to create the graft distribution system.

The bone graft distribution systems provided herein also have additional means for retaining the central beam in the laterover vertically expanding frame. In some embodiments, the inserting of the central beam into the laterover vertically expanding frame includes engaging a ratchet mechanism comprising a protuberance on the central beam that engages with the laterover vertically-expanding frame to prevent the central beam from backing out of the laterover vertically-expanding frame after the expanding.

Moreover, the bone graft distribution systems provided herein can be in the form of a kit. The kits can include, for example, a graft distribution system taught herein, a cannula for inserting the graft distribution system into the intervertebral space, a guidewire adapted for guiding the central beam into the laterover vertically expanding frame, and an expansion handle for inserting the central beam into the laterover vertically expanding frame to form the graft distribution system.

FIGS. 8A-8D illustrate components of a kit, according to some embodiments. FIGS. 8A and 8B illustrate a 4-sided funnel cannula **805** as taught herein having a shaft **810** forming a channel **815**, a funnel **820** for guiding a laterover vertically expandable frame into an annulus in a low-profile configuration, the cannula shown with an obturator **825** in the channel **815** of the cannula **805**, the cannula **805** inserted posterolaterally through an annulotomy **877** in the annulus **888**, into an

intervertebral space **899**, with the distal end of the cannula **805** position near the inner anterior wall of the annulus **888**. FIG. **8C** illustrates FIG. **8A** with a guidewire used to insert the lateroververtically expandable frame **749** into the funnel **820** of the cannula **805** to guide the frame **749** into the annulus **888** in the low profile, collapsed state of the frame **749**. FIG. **8D** illustrates an expansion handle **855** having trigger **856** that pushes a pushrod **857** along the guidewire **866** while holding the guidewire to push on the proximal end of the central beam **701** to insert the central beam **701** into the frame **749** to expand the frame **749** by applying equal, or substantially equal forces: a proximally-directed force, F_p , at the connection **708** between the guide plate **707** and the guide wire **866** onto the distal portion of the beams of the frame **749**, and a distally-directed force, F_D , at the proximal end of the central beam **701**.

FIGS. **9A-9C** illustrate the expansion of a lateroververtically-expandable frame in an intervertebral space, according to some embodiments. FIG. **9A** shows a collapsed frame **949** receiving a central beam **901** along a guidewire **966**. FIG. **9B** shows the central beam **901** partially inserted into the frame **949** in an expanded state, the guidewire **966** still in place FIG. **9C** shows how the expanded state may appear when inserted posterolaterally and expanded in the intervertebral space in an annulus **988**. Side ports **942,943** for bone graft distribution are shown through an open bone graft window in the expanded frame **749**.

FIGS. **10A-10C** illustrate profiles of an expanded graft distribution system to highlight the exit ports and bone graft windows, according to some embodiments. Profiles of an expanded frame **1049**, highlighting bone graft windows **1088** and graft ports **1040, 1041, 1042, 1043** as they may appear in an intervertebral space after an implant procedure. The guidewire **1066** is shown as remaining in place.

FIGS. **11A** and **11B** compare an illustration of the graft distribution in place to a test placement in a cadaver to show relative size, according to some embodiments. Likewise, FIGS. **12A-12C** show x-rays of a placement in a cadaver, according to some embodiments.

As described above, the frame **149** can be configured such that the central axis of the first top beam **150** is at least substantially on (i) the top plane and (ii) the first side plane; the central axis of the second top beam **160** is at least substantially on (i) the top plane and (ii) the second side plane; the central axis of the first bottom beam **170** is at least substantially on (i) the bottom plane and (ii) the first side plane; and, the central axis of the second bottom beam being at least substantially on (i) the bottom plane and (ii) the second side plane. It should be appreciated that this configuration provides a “top face” framed by the first top beam and the second top beam, a “bottom face” framed by the first bottom beam and the second bottom beam, a “first side face” framed by the first top beam and the first bottom beam, and a “second side face” framed by the second top beam and the second bottom beam.

In some embodiments, it can be desirable to have the frame expand to shape that is predesigned to fit between the top endplate and the bottom endplate of the intervertebral space in a manner that calls, for example, for opposing faces of the frames to be something other than “at least substantially parallel.” For example, it may be desired to have the two opposing sides of the frame expand such that the central axis of the first top beam is no longer at least substantially parallel to the central axis of the second top beam. Likewise, it may be desired to have the two opposing sides of the frame expand such that the central axis of the first bottom beam is no longer at least substantially parallel to the central axis of the second

bottom beam. Likewise, it may be desired to have the opposing top and bottom sides of the frame expand such that the central axis of the first top beam is no longer at least substantially parallel to the central axis of the first bottom beam. Likewise, it may be desired to have the opposing top and bottom sides of the frame expand such that the central axis of the second top beam is no longer at least substantially parallel to the central axis of the second bottom beam. Or, any combination of the above may be desired. The lateroververtically expandable frames taught herein enable each of these desirable configurations.

FIGS. **13A-13D** show orientations of the first top beam relative to the second top beam, first bottom beam relative to the second bottom beam, first top beam relative to the first bottom beam, and the second top beam relative to the second bottom beam, according to some embodiments. FIG. **13A** shows the first top beam **150** relative to the second top beam **160**, in which the angle θ_T is formed by the two beams to shape the top face of the frame. FIG. **13B** shows the first bottom beam **170** relative to the second bottom beam **180**, in which the angle θ_B is formed by the two beams to shape the bottom face of the frame. FIG. **13C** shows the first top beam **150** relative to the first bottom beam **170**, in which the angle θ_{FS} is formed by the two beams to shape the first side face of the frame. FIG. **13D** shows the second top beam **160** relative to the second bottom beam **180**, in which the angle θ_{SS} is formed by the two beams to shape the second side face of the frame. In some embodiments, each of θ_T , θ_B , θ_{FS} , and θ_{SS} can be independently selected and each can range from 0° to 32° , from 0.5° to 31.5° , from 0.1° to 31.0° , from 1.5° to 30.5° , from 2.0° to 30.0° , from 2.5° to 29.5° , from 3.0° to 29.0° , from 3.5° to 28.5° , from 4.0° to 28.0° , from 4.5° to 27.5° , from 5.0° to 27° , from 5.5° to 26.5° , from 6.0° to 26.0° , from 6.5° to 25.5° , from 7.0° to 25.0° , from 7.5° to 25.5° , from 8.0° to 26.0° , from 8.5° to 26.5° , from 9.0° to 26.0° , from 9.5° to 25.5° , from 10.0° to 25.0° , from 10.5° to 24.5° , from 11.0° to 24.0° , from 11.5° to 23.5° , from 12.0° to 23.0° , from 12.5° to 22.5° , from 13.0° to 22.0° , from 13.5° to 21.5° , from 14.5° to 21.0° , from 15.5° to 20.5° , from 16.0° to 20.0° , from 16.5° to 19.5° , from 17.0° to 19.0° , or any range therein in increments of 0.1° . In some embodiments, each of θ_T , θ_B , θ_{FS} , and θ_{SS} can be independently selected and each can be about 1° , 2° , 3° , 4° , 5° , 6° , 7° , 8° , 9° , 10° , 11° , 12° , 13° , 14° , 15° , 16° , 17° , 18° , 19° , 20° , 21° , 22° , 23° , 24° , 25° , 26° , 27° , 28° , 29° , 30° , 31° , 32° , 33° , 34° , 35° , or any angle therein in increments of 0.1° .

It should be appreciated that the beams can each be independently designed to have its own, independently selected curvature, whether convex or concave, and the curvatures can be the same or different between beams that share a face of the frame. And, the curvatures can be opposing for beams that form opposing faces of the frame. Moreover, the frame can have a mixture of one or more straight and one or more curved beams.

Given the above, it should be appreciated that the frames can be designed according to nearly any opening bordered by the top vertebral endplate and bottom vertebral endplate of an intervertebral space, as well as according to a given clinical treatment regardless of the opening dimensions prior to treatment. In some embodiments, the top face of the frame can be at least substantially parallel to the bottom face of the frame, whereas the first side face of the frame and the second side face of the frame can be oriented at angles θ_T and θ_B , wherein θ_T and θ_B can be independently selected to be the same or different. Likewise, in some embodiments, the first side face of the frame can be at least substantially parallel to the second side face of the frame, whereas the top face of the frame and the bottom face of the frame can be oriented at angles θ_{FS} and

θ_{SS} , wherein θ_{FS} and θ_{SS} can be independently selected to be the same or different. In some embodiments, each of θ_T , θ_B , θ_{FS} , and θ_{SS} can be independently selected to range from about 5° to about 32°, from about 7° to about 22°, and from about 8° to about 16°, in some embodiments. As such, any of a variety of frames can be constructed from any of a variety of quadrilateral structures having the angles taught herein.

In some embodiments, the systems include a stabilizer that slidably engages with the distal region of the first top beam, the first bottom beam, the second top beam, the second bottom beam, or a combination thereof. The stabilizer serves the function of the guide plate taught herein and can also be configured for retaining the first top beam, the first bottom beam, the second top beam, the second bottom beam, or the combination thereof, from a lateral movement that exceeds the expanded state.

And, in some embodiments, the framing can be configured for engaging with the central beam in vivo to support the framing in the expanded state. Moreover, the connector elements can be struts configured to have a cross-sectional aspect ratio of longitudinal thickness to transverse thickness ranging from 1:2 to 1:8, adapted to maintain structural stiffness in the laterover vertically expanding frame in a direction perpendicular to the central frame axis of the expanded state of the frame.

FIGS. 14A-14D illustrate components of a system having a stabilizer, wherein the stabilizer is in an X-configuration, according to some embodiments. As shown in FIG. 14A, the system 1400 can include a stabilizer 1407 that can be in an X-configuration. In some embodiments, the X-configuration can have a first top leg TL_1 for slidably-engaging with the first top beam 1450 at an angle θ_{1T} with the intended lateral movement LM_{1T} of the first top beam 1450, first bottom leg BL_1 for slidably engaging with the first bottom beam 1470 at an angle θ_{1B} with the intended lateral movement LM_{1B} of the first bottom beam 1470, a second top leg TL_2 for slidably engaging with the second top beam 1480 at an angle θ_{2T} with the intended lateral movement LM_{2T} of the second top beam 1460, and a second bottom leg BL_2 for slidably engaging with the second bottom beam 1480 at an angle θ_{2B} with the intended lateral movement LM_{2B} of the second bottom beam 1480.

In some embodiments, each of the angles θ_{1T} , θ_{1B} , θ_{2T} , θ_{2B} , respectively, provide a tensile force for resisting the first top beam 1450, the first bottom beam 1470, the second top beam 1460, and the second bottom beam 1480 from the lateral movement LM_{1T} , LM_{2T} , LM_{1B} , LM_{2B} that exceeds the expanded state. In some embodiments, each of the angles θ_{1T} , θ_{1B} , θ_{2T} , θ_{2B} can be independently selected from an amount of angulation ranging from about 15° to about 75°, from about 20° to about 75°, from about 25° to about 75°, from about 30° to about 75°, from about 35° to about 75°, from about 55° to about 75°, from about 15° to about 70°, from about 15° to about 65°, from about 15° to about 60°, from about 15° to about 55°, from about 15° to about 50°, from about 15° to about 45°, or any range therein. In some embodiments, each of the angles θ_{1T} , θ_{1B} , θ_{2T} , θ_{2B} can be independently selected from an amount of angulation that is about 10°, about 15°, about 20°, about 25°, about 30°, about 35°, about 40°, about 45°, about 50°, about 55°, about 60°, about 65°, about 70°, about 75°, about 80°, or any angulation therein in amounts of 1°.

In some embodiments, the stabilizer 1407 further comprises a point of attachment 1408 for releasably attaching a guidewire (not shown) for guiding the central beam 1401 into the laterover vertically expanding frame comprising the first top beam 1450, the second top beam 1460, the first bottom beam

1470, and the second bottom beam 1480. And, in some embodiments, the first top leg TL_1 , the first bottom leg BL_1 , the second top leg TL_2 , and the second bottom leg BL_2 converge to form a hub 1408H having a point of attachment 1408 on the posterior surface of the hub 1408H for releasably attaching a guidewire (not shown) for guiding the central beam 1401 into the laterover vertically expanding frame. The point of attachment might be, for example, a male or female threaded component, or any other releasable connector known to one of skill. And, the beams 1450, 1460, 1470, 1480 can be configured with ports TP_1 , TP_2 , BP_1 , BP_2 for passage of the respective legs TL_1 , TL_2 , BL_1 , BL_2 of the stabilizer 1407. FIGS. 14B and 14C show the system in a collapsed configuration and expanded side configuration, respectively. In some embodiments, the central beam 1401 can include one or more bone graft distribution ports 1466. And, as in other embodiments taught herein, the beams 1450, 1460, 1470, 1480 can be interconnected using flexible struts 1495.

FIGS. 15A-15D illustrate components of a system having a stabilizer, wherein the stabilizer is in an H-configuration, according to some embodiments. The H-configuration can have a first vertical leg VL_1 , a second vertical leg VL_2 , and a cross-member CM that connects the first vertical leg VL_1 at least substantially parallel to the second vertical leg VL_2 , the first vertical leg VL_1 including a first retaining surface RS_1 for engaging with the first top beam 1550 and the first bottom beam 1570, the second vertical leg VL_2 including a second retaining surface RS_2 for engaging with the second top beam 1560 and the second bottom beam 1580, and the cross member CM providing a tensile force for resisting the first top beam 1550, the first bottom beam 1570, the second top beam 1560, and the second bottom beam 1580 from the lateral movement that exceeds the expanded state. In some embodiments, the central beam 1501 has a horizontal groove HG configured complementary to the cross-member CM of the stabilizer 1507, and the horizontal groove HG of the central beam 1501 slidably connects with the cross-member CM in the expanded state. In some embodiments, the cross-member CM further comprises a vertical support member VSM and the central beam 1501 has a vertical groove VG configured complementary to the vertical support member VSM of the stabilizer, and the vertical groove VG of the central beam 1501 slidably connects with the vertical support member VSM in the expanded state. In some embodiments, the stabilizer 1507 further comprises a point of attachment 1508 at a hub 1508H for releasably attaching a guidewire (not shown) adapted for guiding the central beam 1501 into the laterover vertically expanding frame comprising the first top beam 1550, the second top beam 1560, the first bottom beam 1570, and the second bottom beam 1580. guidewire (not shown) for guiding the central beam 1501 into the laterover vertically expanding frame. The point of attachment might be, for example, a male or female threaded component, or any other releasable connector known to one of skill. And, the beams 1550, 1560, 1570, 1580 can be configured with slots S_1 , S_2 in which the vertical legs VL_1 , VL_2 can travel during the lateral expansion of the beams 1550, 1560, 1570, 1580 of the expandable frame. And, in some embodiments, cross-member CM includes a first pillar P_1 and a second pillar P_2 that operably connect at a hub that has the point of attachment 1508 for releasably attaching the guidewire (not shown) for guiding the central beam 1501 into the laterover vertically expanding frame. In some embodiments, the central beam 1501 can include one or more bone graft distribution ports 1566. And, as in other embodiments taught herein, the beams 1550, 1560, 1570, 1580 can be interconnected using flexible struts 1595.

One of skill will appreciate that the teachings provided herein are directed to basic concepts that can extend beyond any particular embodiment, embodiments, figure, or figures. It should be appreciated that any examples are for purposes of illustration and are not to be construed as otherwise limiting to the teachings. For example, it should be appreciated that the devices provided herein can also be used as implants in other areas of the body. The devices provided herein can be used, for example, in intravertebral body procedures to support or distract vertebral bodies in the repair of, for example, collapsed, damaged or unstable vertebral bodies suffering from disease or injury.

We claim:

1. An intervertebral scaffolding system, comprising; a laterover vertically-expanding frame configured to create an intervertebral scaffolding system in vivo, the frame having
 - a collapsed state and an expanded state, the expanded state operably contacting the intervertebral space;
 - a proximal portion having an end, a distal portion having an end, and a central frame axis of the expanded state;
 - a first top beam including a proximal portion having an end and a distal portion having an end, the central axis of the first top beam at least substantially on (i) a top plane containing the central axis of the first top beam and a central axis of a second top beam and (ii) a first side plane containing the central axis of the first top beam and a central axis of a first bottom beam;
 - the second top beam including a proximal portion having an end and a distal portion having an end, the central axis of the second top beam at least substantially on (i) the top plane and (ii) a second side plane containing the central axis of the second top beam and a central axis of a second bottom beam;
 - the first bottom beam including a proximal portion having an end and a distal portion having an end, the central axis of the first bottom beam at least substantially on (i) a bottom plane containing the central axis of the first bottom beam and the central axis of the second top beam and (ii) the first side plane;
 - the second bottom beam including a proximal portion having an end and a distal region having an end, the central axis of the second bottom beam being at least substantially on (i) the bottom plane and (ii) a second side plane containing the central axis of the second bottom beam and the central axis of the second top beam;
 - a plurality of top connector elements configured to expandably connect the first top beam to the second top beam, the expanding consisting of a flexing at least substantially on the top plane;
 - a plurality of bottom connector elements configured to expandably connect the first bottom beam to the second bottom beam, the expanding consisting of a flexing at least substantially on the bottom plane;
 - a plurality of first side connector elements configured to expandably connect the first top beam to the first bottom beam, the expanding consisting of a flexing at least substantially on the first side plane;
 - a plurality of second side connector elements configured to expandably connect the second top beam to the second bottom beam, the expanding consisting of a flexing at least substantially on the second side plane;
- and,
- a stabilizer that slidably engages with the distal region of the first top beam, the first bottom beam, the second top beam, the second bottom beam, or a combination

thereof, and is configured for retaining the first top beam, the first bottom beam, the second top beam, the second bottom beam, or the combination thereof, from a lateral movement that exceeds the expanded state; wherein,

the connector elements are configured to maintain structural stiffness in the laterover vertically-expanding frame.

2. The scaffolding system of claim 1, wherein the stabilizer is in an X-configuration having a first top leg for slidably-engaging with the first top beam at an angle θ_{1T} with the lateral movement of the first top beam, first bottom leg for slidably engaging with the first bottom beam at an angle θ_{1B} with the lateral movement of the first bottom beam, a second top leg for slidably engaging with the second top beam at an angle θ_{2T} with the lateral movement of the second top beam, and a second bottom leg for slidably engaging with the second bottom beam at an angle θ_{2B} with the lateral movement of the second bottom beam, wherein each of the angles θ_{1T} , θ_{1B} , θ_{2T} , θ_{2B} respectively, provide a tensile force for resisting the first top beam, the first bottom beam, the second top beam, and the second bottom beam from the lateral movement that exceeds the expanded state.

3. The scaffolding system of claim 1, wherein the stabilizer is in an X-configuration having a first top leg for slidably-engaging with the first top beam at an angle θ_{1T} with the lateral movement of the first top beam, first bottom leg for slidably engaging with the first bottom beam at an angle θ_{1B} with the lateral movement of the first bottom beam, a second top leg for slidably engaging with the second top beam at an angle θ_{2T} with the lateral movement of the second top beam, and a second bottom leg for slidably engaging with the second bottom beam at an angle θ_{2B} with the lateral movement of the second bottom beam, wherein each of the angles θ_{1T} , θ_{1B} , θ_{2T} , θ_{2B} , respectively, provide a tensile force for resisting the first top beam, the first bottom beam, the second top beam, and the second bottom beam from the lateral movement that exceeds the expanded state;

wherein, the system further comprises an expansion member, and the stabilizer further comprises a point of attachment for releasably attaching a guidewire for guiding the expansion member into the laterover vertically expanding frame.

4. The scaffolding system of claim 1, wherein the stabilizer is in an X-configuration having a first top leg for slidably-engaging with the first top beam at an angle θ_{1T} with the lateral movement of the first top beam, first bottom leg for slidably engaging with the first bottom beam at an angle θ_{1B} with the lateral movement of the first bottom beam, a second top leg for slidably engaging with the second top beam at an angle θ_{2T} with the lateral movement of the second top beam, and a second bottom leg for slidably engaging with the second bottom beam at an angle θ_{2B} with the lateral movement of the second bottom beam, wherein each of the angles θ_{1T} , θ_{1B} , θ_{2T} , θ_{2B} , respectively, provide a tensile force for resisting the first top beam, the first bottom beam, the second top beam, and the second bottom beam from the lateral movement that exceeds the expanded state;

wherein, the system further comprises an expansion member, and the first top leg, the first bottom leg, the second top leg, and the second bottom leg converge to form a hub having a point of attachment for releasably attaching a guidewire for guiding the expansion member into the laterover vertically expanding frame.

5. The scaffolding system of claim 1, wherein the stabilizer is in an H-configuration having a first vertical leg, a second vertical leg, and a cross-member that connects the first vertical leg at least substantially parallel to the second vertical leg,

29

the first vertical leg including a retaining surface for engaging with the first top beam and the first bottom beam, the second vertical leg including a retaining surface for engaging with the second top beam and the second bottom beam, and the cross member providing a tensile force for resisting the first top beam, the first bottom beam, the second top beam, and the second bottom beam from the lateral movement that exceeds the expanded state.

6. The scaffolding system of claim 1, wherein the stabilizer is in an H-configuration having a first vertical leg, a second vertical leg, and a cross-member that connects the first vertical leg at least substantially parallel to the second vertical leg, the first vertical leg including a retaining surface for engaging with the first top beam and the first bottom beam, the second vertical leg including a retaining surface for engaging with the second top beam and the second bottom beam, and the cross member providing a tensile force for resisting the first top beam, the first bottom beam, the second top beam, and the second bottom beam from the lateral movement that exceeds the expanded state;

wherein, the system further comprises an expansion member with a horizontal groove configured complementary to the cross-member of the stabilizer, and the horizontal groove of the expansion member slidably connects with the cross-member in the expanded state.

7. The scaffolding system of claim 1, wherein the stabilizer is in an H-configuration having a first vertical leg, a second vertical leg, a cross-member that connects the first vertical leg at least substantially parallel to the second vertical leg, the first vertical leg including a retaining surface for engaging with the first top beam and the first bottom beam, the second vertical leg including a retaining surface for engaging with the second top beam and the second bottom beam, and the cross member providing a tensile force for resisting the first top beam, the first bottom beam, the second top beam, and the second bottom beam from the lateral movement that exceeds the expanded state;

wherein, the system further comprises an expansion member, and the cross-member further comprises a vertical support member, the expansion member having a vertical groove configured complementary to the vertical support member of the stabilizer, and the vertical groove of the expansion member slidably connects with the vertical support member in the expanded state.

8. The scaffolding system of claim 1, wherein the stabilizer is in an H-configuration having a first vertical leg, a second vertical leg, a cross-member that connects the first vertical leg at least substantially parallel to the second vertical leg, the first vertical leg including a retaining surface for engaging with the first top beam and the first bottom beam, the second vertical leg including a retaining surface for engaging with the second top beam and the second bottom beam, and the cross member providing a tensile force for resisting the first top beam, the first bottom beam, the second top beam, and the second bottom beam from the lateral movement that exceeds the expanded state;

wherein, the system further comprises an expansion member, and the stabilizer further comprises a point of attachment for releasably attaching a guidewire adapted for guiding the expansion member into the laterover vertically expanding frame.

9. The scaffolding system of claim 1, wherein the stabilizer is in an H-configuration having a first vertical leg, a second vertical leg, a cross-member that connects the first vertical leg at least substantially parallel to the second vertical leg, the first vertical leg including a retaining surface for engaging with the first top beam and the first bottom beam, the second

30

vertical leg including a retaining surface for engaging with the second top beam and the second bottom beam, and the cross member providing a tensile force for resisting the first top beam, the first bottom beam, the second top beam, and the second bottom beam from the lateral movement that exceeds the expanded state;

wherein, the system further comprises an expansion member, and the cross-member includes a first pillar and a second pillar that operably connect at a hub that has a point of attachment for releasably attaching a guidewire for guiding the expansion member into the laterover vertically expanding frame.

10. The scaffolding system of claim 1 further comprising a grafting port.

11. The scaffolding system of claim 1, wherein each plurality connector elements are struts; and, wherein,

the top struts are configured monolithically integral to the first top beam and the second top beam; and,

the bottom struts are configured monolithically integral to the first bottom beam and the second bottom beam;

wherein, the top struts and bottom struts of the laterover vertically-expanding frame are each configured to open a graft distribution window upon expansion, expanding from the first top beam to the second top beam, the first top beam to the first bottom beam, the second top beam to the second bottom beam, or the first bottom beam to the second bottom beam.

12. The scaffolding system of claim 1, wherein, the top connector struts are configured monolithically integral to the first top beam and the second top beam; and, the bottom struts are configured monolithically integral to the first bottom beam and the second bottom beam; the first side struts are configured monolithically integral to the first top beam and the first bottom beam; and, the second side struts are configured monolithically integral to the second top beam and the second bottom beam; wherein, the top, bottom, first side, and second side of the laterover vertically-expanding frame form a monolithically integral frame.

13. A method of fusing an intervertebral space using the scaffolding system of claim 1, the method comprising:

creating a point of entry into an intervertebral disc, the intervertebral disc having a nucleus pulposus surrounded by an annulus fibrosis;

removing the nucleus pulposus from within the intervertebral disc through the point of entry, leaving the intervertebral space for expansion of the scaffolding system of claim 1 within the annulus fibrosis, the intervertebral space having a top vertebral plate and a bottom vertebral plate;

inserting the laterover vertically expanding frame in the collapsed state through the point of entry into the intervertebral space;

expanding the laterover vertically expanding frame to form the scaffolding system;

and, adding a grafting material to the intervertebral space.

14. The method of claim 13, wherein the creating the point of entry comprises creating a lateral dimension of the point of entry ranging from about 5 mm to about 15 mm, and the amount of lateral expansion is selected to exceed the lateral dimension of the point of entry.

15. The method of claim 13, wherein the expanding includes

expanding the laterover vertically expanding frame laterally to a width that exceeds the width of the point of entry; and,

expanding the laterover vertically expanding frame vertically
to support the intervertebral space in the expanded state.

16. The method of claim **13**, wherein the expanding the
laterover vertically expanding frame includes inserting an expansion
member and engaging a means for preventing the expansion
member from backing out of the laterover vertically-expanding
frame after the expanding. 5

17. A kit, comprising:

the scaffolding system of claim **1**;

a cannula for inserting the scaffolding system into the
intervertebral space; and, 10

a guidewire adapted for guiding an expansion member into
the laterover vertically expanding frame.

18. A kit, comprising:

the scaffolding system of claim **2**;

a cannula for inserting the scaffolding system into the
intervertebral space; and, 15

a guidewire adapted for guiding an expansion member into
the laterover vertically expanding frame.

19. A kit, comprising:

the scaffolding system of claim **4**;

a cannula for inserting the scaffolding system into the
intervertebral space; and, 20

a guidewire adapted for guiding the expansion member
into the laterover vertically expanding frame. 25

20. A kit, comprising:

the scaffolding system of claim **6**;

a cannula for inserting the scaffolding system into the
intervertebral space; and,

a guidewire adapted for guiding the expansion member
into the laterover vertically expanding frame. 30

* * * * *