

US009396633B1

(12) **United States Patent**  
**Sannala**

(10) **Patent No.:** **US 9,396,633 B1**  
(45) **Date of Patent:** **Jul. 19, 2016**

(54) **SYSTEMS, METHODS, AND DEVICES FOR MANAGING COEXISTENCE OF MULTIPLE TRANSCEIVER DEVICES BY OPTIMIZING COMPONENT LAYOUT**

(71) Applicant: **Google Inc.**, Mountain View, CA (US)

(72) Inventor: **Mikko Pekka Sannala**, Los Gatos, CA (US)

(73) Assignee: **GOOGLE INC.**, Mountain View, CA (US)

(\* ) Notice: Subject to any disclaimer, the term of this patent is extended or adjusted under 35 U.S.C. 154(b) by 0 days.

(21) Appl. No.: **14/819,373**

(22) Filed: **Aug. 5, 2015**

**Related U.S. Application Data**

(60) Provisional application No. 62/175,393, filed on Jun. 14, 2015.

(51) **Int. Cl.**  
**H04N 7/18** (2006.01)  
**G08B 13/196** (2006.01)  
**H01Q 1/24** (2006.01)  
(Continued)

(52) **U.S. Cl.**  
CPC ..... **G08B 13/19619** (2013.01); **H01Q 1/2291** (2013.01); **H01Q 1/24** (2013.01); **H04N 5/2254** (2013.01)

(58) **Field of Classification Search**  
CPC ..... H04N 7/18; G06K 9/00771; G06K 9/00; G08B 13/196  
USPC ..... 348/143  
See application file for complete search history.

(56) **References Cited**

U.S. PATENT DOCUMENTS

2,101,637 A 12/1937 Davis  
3,681,603 A 8/1972 Scheidweiler et al.  
3,948,441 A 4/1976 Perkins et al.

(Continued)

FOREIGN PATENT DOCUMENTS

CN 101305248 11/2008  
CN 101522447 9/2009

(Continued)

OTHER PUBLICATIONS

Detroitborg, Nest Learning Thermostat: Unboxing and Review, (online), retrieved from the Internet: URL: <http://www.youtube.com/watch?v=KrgcOL4oLzc>, retrieved on Aug. 22, 2013, Feb. 10, 2012, pgs.

(Continued)

*Primary Examiner* — Shan Elahi

(74) *Attorney, Agent, or Firm* — Morgan, Lewis & Bockius LLP

(57) **ABSTRACT**

A camera assembly includes an enclosed housing having a rear surface, a front surface, and a periphery. The camera assembly also includes a lens module located within the housing and configured to receive light via the front surface, and communication circuitry located within the housing and configured to wireless communicate over a plurality of different communication protocols. The camera assembly further includes a first antenna arranged at a first location on an inner surface of the periphery, the first antenna configured for communication over a first one of the communication protocols, and a second antenna arranged at a second location on the inner surface of the periphery, the second location being different than the first location, the second antenna configured for communication over a second one of the communication protocols.

**19 Claims, 50 Drawing Sheets**

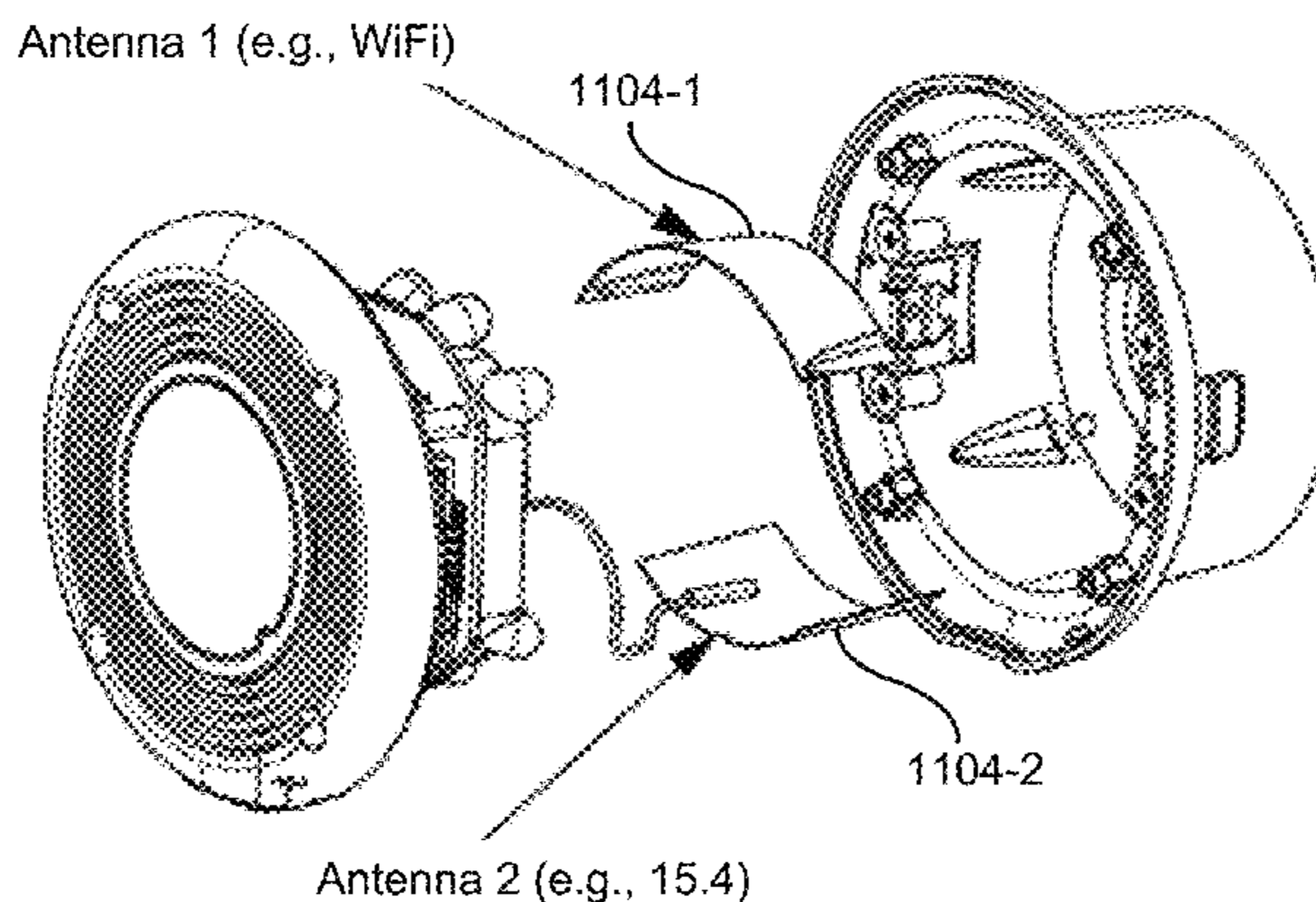



(51)	<b>Int. Cl.</b>			6,622,925 B2	9/2003	Carner et al.	
	<i>H01Q 1/22</i>	(2006.01)		6,657,418 B2	12/2003	Atherton	
	<i>H04N 5/225</i>	(2006.01)		6,743,010 B2	6/2004	Bridgeman et al.	
				6,778,091 B2	8/2004	Qualey, III et al.	
				6,794,771 B2	9/2004	Orloff	
(56)	<b>References Cited</b>			6,798,341 B1	9/2004	Eckel et al.	
	<b>U.S. PATENT DOCUMENTS</b>			6,886,754 B2	5/2005	Smith et al.	
				6,956,463 B2	10/2005	Crenella et al.	
				7,174,239 B2	2/2007	Butler et al.	
				7,200,467 B2	4/2007	Schanin et al.	
	3,991,357 A	11/1976	Kaminski	7,476,988 B2	1/2009	Mulhouse et al.	
	4,121,110 A	10/1978	Solomon	7,510,126 B2	3/2009	Rossi et al.	
	4,157,506 A	6/1979	Spencer	7,537,171 B2	5/2009	Mueller et al.	
	4,177,923 A	12/1979	Krump	7,571,865 B2	8/2009	Nicodem et al.	
	4,225,860 A	9/1980	Conforti	7,579,945 B1	8/2009	Richter et al.	
	4,249,696 A	2/1981	Donnelly et al.	7,592,923 B2	9/2009	Lax	
	4,308,991 A	1/1982	Peinetti et al.	7,648,077 B2	1/2010	Rossi et al.	
	4,319,234 A	3/1982	Rice	7,673,809 B2	3/2010	Juntunen	
	4,460,125 A	7/1984	Barker et al.	7,748,640 B2	7/2010	Roher et al.	
	4,528,459 A	7/1985	Wiegel	7,755,220 B2	7/2010	Sorg et al.	
	4,695,246 A	9/1987	Beilfuss et al.	7,775,452 B2	8/2010	Shah et al.	
	4,842,510 A	6/1989	Grunden	7,841,542 B1	11/2010	Rosen	
	4,845,474 A	7/1989	Moore et al.	7,900,849 B2	3/2011	Barton et al.	
	4,872,828 A	10/1989	Mierzwinski et al.	7,982,602 B2	7/2011	Kates	
	4,898,229 A	2/1990	Brown et al.	7,994,928 B2	8/2011	Richmond	
	4,948,044 A	8/1990	Cacciatore	8,016,205 B2	9/2011	Drew	
	4,955,805 A	9/1990	Ishiguro et al.	8,091,375 B2	1/2012	Crawford	
	4,955,806 A	9/1990	Grunden et al.	8,098,166 B2	1/2012	Lang	
	5,107,918 A	4/1992	McFarlane et al.	8,232,884 B2	7/2012	Pattok et al.	
	5,127,464 A	7/1992	Butler	8,255,090 B2	8/2012	Frader-Thompson et al.	
	5,158,477 A	10/1992	Testa	8,265,798 B2	9/2012	Imes	
	5,175,439 A	12/1992	Harer et al.	8,415,829 B2	4/2013	Di Cristofaro	
	5,251,813 A	10/1993	Knierkamp	8,706,270 B2	4/2014	Fadell et al.	
	5,255,179 A	10/1993	Zekan et al.	8,752,711 B2	6/2014	Campbell et al.	
	5,260,669 A	11/1993	Higgins et al.	2002/0044061 A1	4/2002	Johnson et al.	
	5,277,363 A	1/1994	Hart	2002/0063472 A1	5/2002	Irvin	
	5,347,982 A	9/1994	Binzer et al.	2002/0074865 A1	6/2002	Zimmerman et al.	
	5,352,930 A	10/1994	Ratz	2003/0037555 A1	2/2003	Street et al.	
	5,381,950 A	1/1995	Aldridge	2003/0064335 A1	4/2003	Canon	
	5,422,808 A	6/1995	Catanese, Jr. et al.	2003/0090243 A1	5/2003	Atherton	
	5,452,762 A	9/1995	Zillner, Jr.	2003/0231001 A1	12/2003	Bruning	
	5,456,407 A	10/1995	Stalsberg et al.	2004/0120084 A1	6/2004	Readio et al.	
	5,460,327 A	10/1995	Hill et al.	2004/0192219 A1	9/2004	Malone et al.	
	5,462,225 A	10/1995	Massara et al.	2004/0209209 A1	10/2004	Chodacki et al.	
	5,467,921 A	11/1995	Shreeve et al.	2004/0245349 A1	12/2004	Smith	
	5,506,569 A	4/1996	Rowlette	2005/0043907 A1	2/2005	Eckel et al.	
	5,544,036 A	8/1996	Brown, Jr. et al.	2005/0145705 A1	7/2005	Shah et al.	
	5,570,837 A	11/1996	Brown et al.	2005/0195757 A1	9/2005	Kidder et al.	
	5,589,824 A	12/1996	Lynch	2005/0215284 A1	9/2005	Su et al.	
	5,595,342 A	1/1997	McNair et al.	2005/0270151 A1	12/2005	Winick	
	5,611,484 A	3/1997	Uhrich	2006/0035657 A1	2/2006	Lim	
	5,635,896 A	6/1997	Tinsley et al.	2006/0102731 A1	5/2006	Mueller et al.	
	5,646,349 A	7/1997	Twigg et al.	2006/0124759 A1	6/2006	Rossi et al.	
	5,655,709 A	8/1997	Garnett et al.	2006/0132301 A1*	6/2006	Stilp .....	G05B 9/03 340/539.22
	5,697,552 A	12/1997	McHugh et al.				
	5,719,557 A	2/1998	Rattman et al.				
	5,736,795 A	4/1998	Zuehlke	2006/0133334 A1	6/2006	Ross	
	5,808,294 A	9/1998	Neumann	2006/0186214 A1	8/2006	Simon et al.	
	5,903,139 A	5/1999	Kompelien	2007/0045432 A1	3/2007	Juntunen	
	5,918,474 A	7/1999	Khanpara et al.	2007/0095082 A1	5/2007	Garrett et al.	
	5,966,077 A	10/1999	Wong	2007/0114848 A1	5/2007	Mulhouse et al.	
	6,060,719 A	5/2000	DiTucci et al.	2007/0115951 A1	5/2007	Karaoguz et al.	
	6,072,784 A	6/2000	Agrawal et al.	2007/0131787 A1	6/2007	Rossi et al.	
	6,084,518 A	7/2000	Jamieson	2007/0228183 A1	10/2007	Kennedy et al.	
	6,084,522 A	7/2000	Addy	2007/0241203 A1	10/2007	Wagner et al.	
	6,089,310 A	7/2000	Toth et al.	2007/0296280 A1	12/2007	Sorg	
	6,114,967 A	9/2000	Yousif	2008/0001734 A1*	1/2008	Stilp .....	G05B 9/03 340/539.22
	6,213,404 B1	4/2001	Dushane et al.				
	6,218,995 B1*	4/2001	Higgins .....	G01D 4/002 340/870.02			
	6,222,719 B1	4/2001	Kadah	2008/0015742 A1	1/2008	Kulyk et al.	
	6,275,160 B1	8/2001	Ha	2008/0054082 A1	3/2008	Evans et al.	
	6,315,211 B1	11/2001	Sartain et al.	2008/0054084 A1	3/2008	Olson	
	6,336,593 B1	1/2002	Bhatnagar	2008/0094010 A1	4/2008	Black	
	6,356,038 B2	3/2002	Bishel	2008/0133956 A1	6/2008	Fadell	
	6,377,182 B1	4/2002	Devine et al.	2008/0147242 A1	6/2008	Roher et al.	
	6,509,838 B1	1/2003	Payne et al.	2009/0099697 A1	4/2009	Li et al.	
	6,513,723 B1	2/2003	Mueller et al.	2009/0140057 A1	6/2009	Leen	
	6,566,768 B2	5/2003	Zimmerman et al.	2009/0194601 A1	8/2009	Flohr	
	6,619,055 B1	9/2003	Addy	2009/0195349 A1	8/2009	Frader-Thompson et al.	
				2009/0236433 A1	9/2009	Mueller et al.	
				2009/0241697 A1	10/2009	Kato et al.	

(56)

References Cited

U.S. PATENT DOCUMENTS

2009/0259713	A1	10/2009	Blumrich et al.	
2010/0006660	A1	1/2010	Leen et al.	
2010/0070099	A1	3/2010	Watson et al.	
2010/0084482	A1	4/2010	Kennedy et al.	
2010/0084918	A1	4/2010	Fells et al.	
2010/0106305	A1	4/2010	Pavlak et al.	
2010/0106322	A1	4/2010	Grohman	
2010/0127881	A1	5/2010	Schechter et al.	
2010/0182743	A1	7/2010	Roher	
2010/0193592	A1	8/2010	Simon et al.	
2010/0238036	A1	9/2010	Holcombe	
2010/0304770	A1	12/2010	Wietfeldt et al.	
2011/0025257	A1	2/2011	Weng	
2011/0045867	A1	2/2011	Jeung et al.	
2011/0152024	A1	6/2011	Kuehl	
2011/0241624	A1	10/2011	Park et al.	
2011/0253796	A1	10/2011	Posa et al.	
2012/0017611	A1	1/2012	Coffel et al.	
2012/0126019	A1	5/2012	Warren et al.	
2012/0248211	A1	10/2012	Warren et al.	
2013/0093594	A1	4/2013	Brigham et al.	
2013/0176401	A1*	7/2013	Monari .....	H04N 5/2252 348/47
2014/0013361	A1*	1/2014	Monari .....	H04N 5/2252 725/62
2014/0279122	A1	9/2014	Luna	
2014/0324410	A1	10/2014	Mathews et al.	
2014/0347478	A1	11/2014	Cho et al.	
2015/0096876	A1*	4/2015	Mittleman .....	H01H 11/00 200/341

FOREIGN PATENT DOCUMENTS

CN	101849311	9/2010
EP	0207295	1/1987
EP	510807	3/1992
EP	660287	12/1994
EP	690363	6/1995
EP	1184804	3/2002
EP	2302326	8/2005
EP	2769275	8/2014
GB	2294828	5/1996
JP	09298780	11/1997
TW	535320	6/2003
TW	200709529	3/2007
TW	201232994	8/2012
WO	WO 2008054938	5/2008

WO	WO 2011131938	10/2011
WO	WO 2012068437	5/2012
WO	WO 2013058820	4/2013

OTHER PUBLICATIONS

First Action Interview Office Action Summary dated on May 29, 2015 for U.S. Appl. No. 14/463,550, filed Aug. 19, 2014, all pages.

International Preliminary Report on Patentability issued Apr. 22, 2014, for International Patent Application No. PCT/US2012/030084 filed Mar. 22, 2012, 5 pgs.

International Preliminary Report on Patentability issued on Feb. 25, 2014 for International Patent Application No. PCT/US2011/061344 filed on Nov. 18, 2011, 7 pgs.

International Search Report and Written Opinion mailed Jul. 6, 2012 for International Patent Application No. PCT/US2012/030084 filed Mar. 22, 2012, 6 pgs.

International Search Report and Written Opinion mailed on Feb. 20, 2014 for International Application No. PCT/US2013/061021, 18 pgs.

International Search Report and Written Opinion mailed on Jul. 14, 2014 for International Patent Application PCT/US14/22834 filed Mar. 10, 2014, all pages.

ISR/WO issued on Jun. 7, 2012 for International Patent Application No. PCT/US2011/061344 filed on Nov. 18, 2011, 9 pages.

Pre-Interview Communication dated on Feb. 27, 2015 for U.S. Appl. No. 14/457,492, filed Aug. 12, 2014, 2 pgs.

Rauchwarnmelder, Design (online), GIRA (retrieved on Mar. 7, 2013). (retrieved from the internet: <URL: <http://gira.de/gebaeudetechnik/produkte/sicherheit/rauchwarnmelderdualdvs.html?vid=1145>>; 2 pgs.

Rauchwarnmelder, Installation and User Manual (online). GIRA (retrieved on Mar. 8, 2013). Retrieved from the internet: <URL: <http://download.gira.de/data2/23301210.pdf>.

Rauchwarnmelder, Datasheet (online), GIRA (retrieved on Mar. 7, 2013). (retrieved from the internet: <URL: <http://gira.de/gebaeudetechnik/produkte/sicherheit/rauchwarnmelderdualdvs.html>>; 6 pgs.

SA720 Smoke Alarm User Manual, First Alert, Aug. 2007, 6 pgs.

Shadrach, Energy Scavenging for Wireless Sensor Nodes with a Focus on Vibration to Electricity Conversion, Dissertation [online], retrieved from the Internet: <URL: <http://users.cecs.anu.edu.au/~Shad.Roundy/paper/ShadThesis.pdf>>, Jun. 2003, 297 pages.

Smoke Alarm User Manual, Kidde, i9060, Dec. 1, 2009, 2 pgs.

U.S. Appl. No. 13/034,678, Non-Final Office Action mailed on Aug. 19, 2013, 9 pages.

U.S. Appl. No. 13/034,678, Notice of Allowance mailed on Feb. 4, 2014, 9 pages.

\* cited by examiner



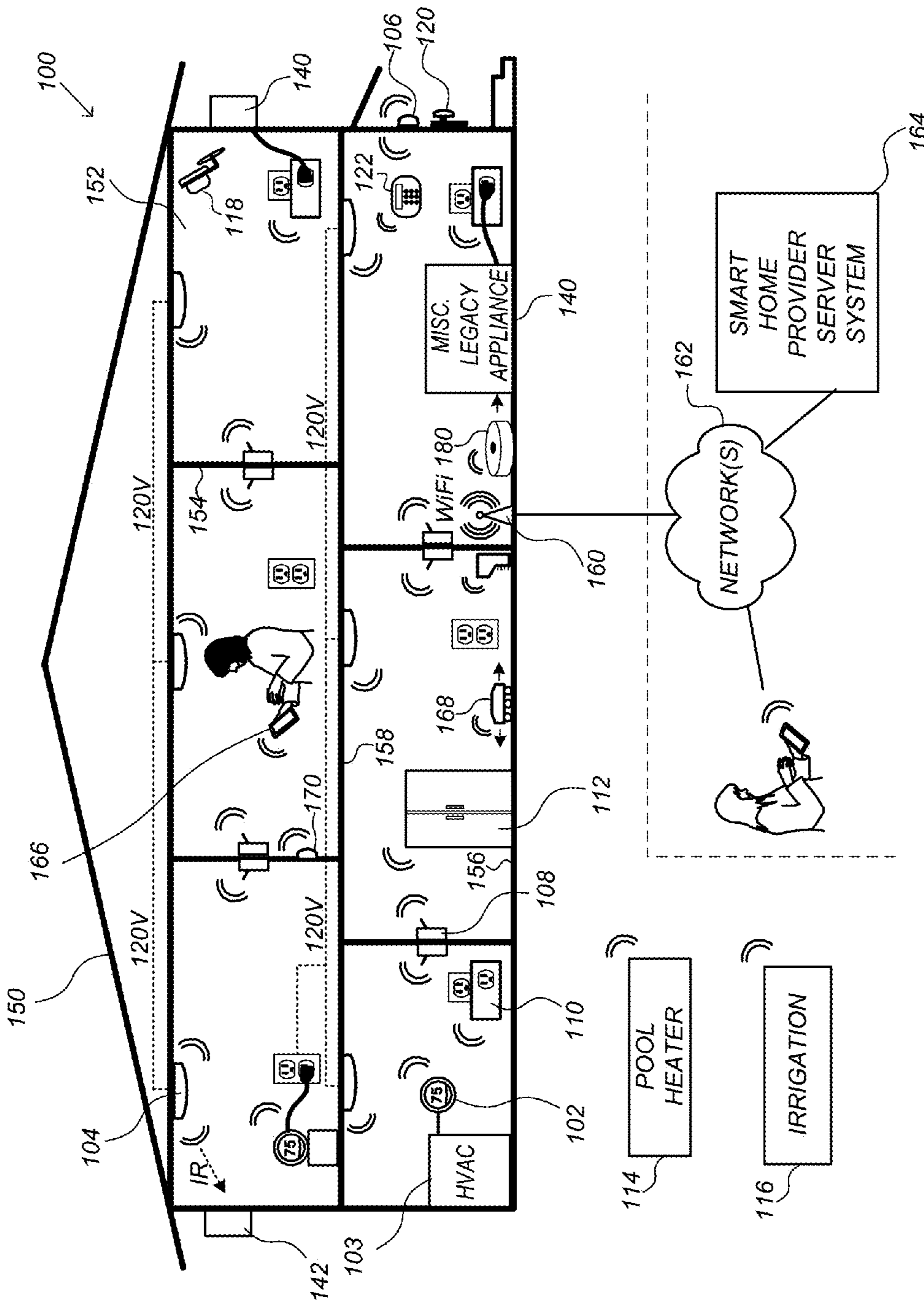

Figure 1

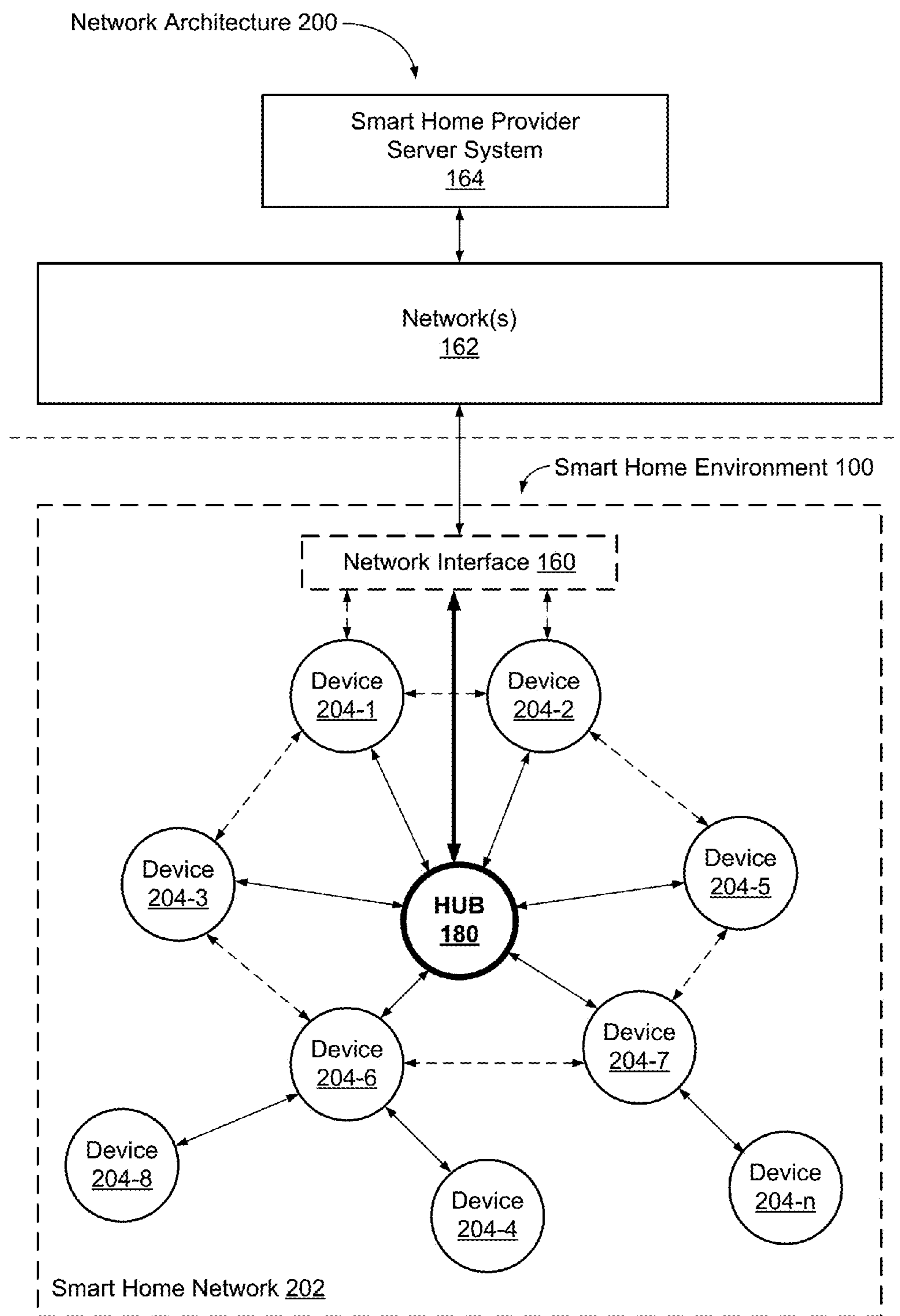

Figure 2

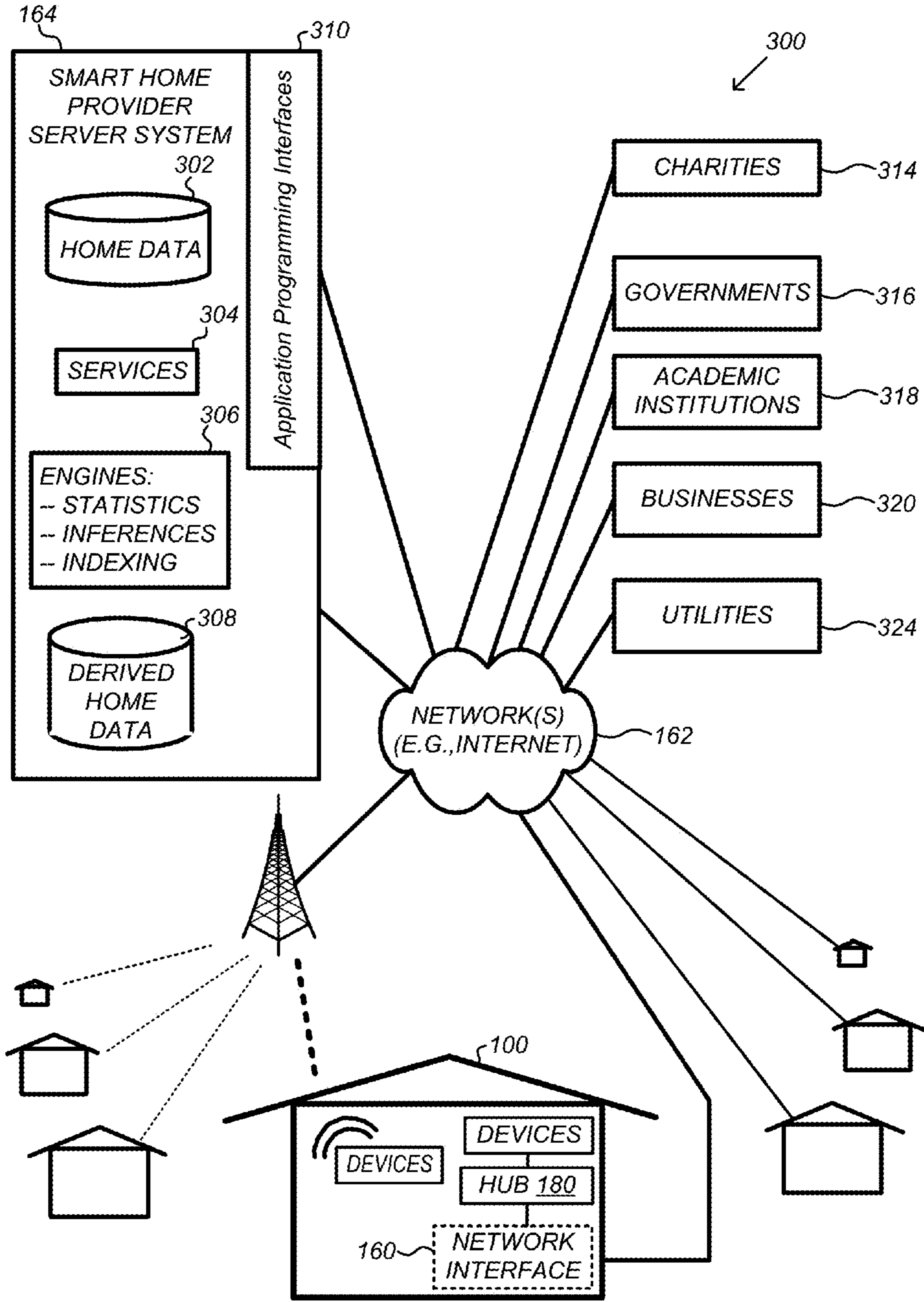

Figure 3

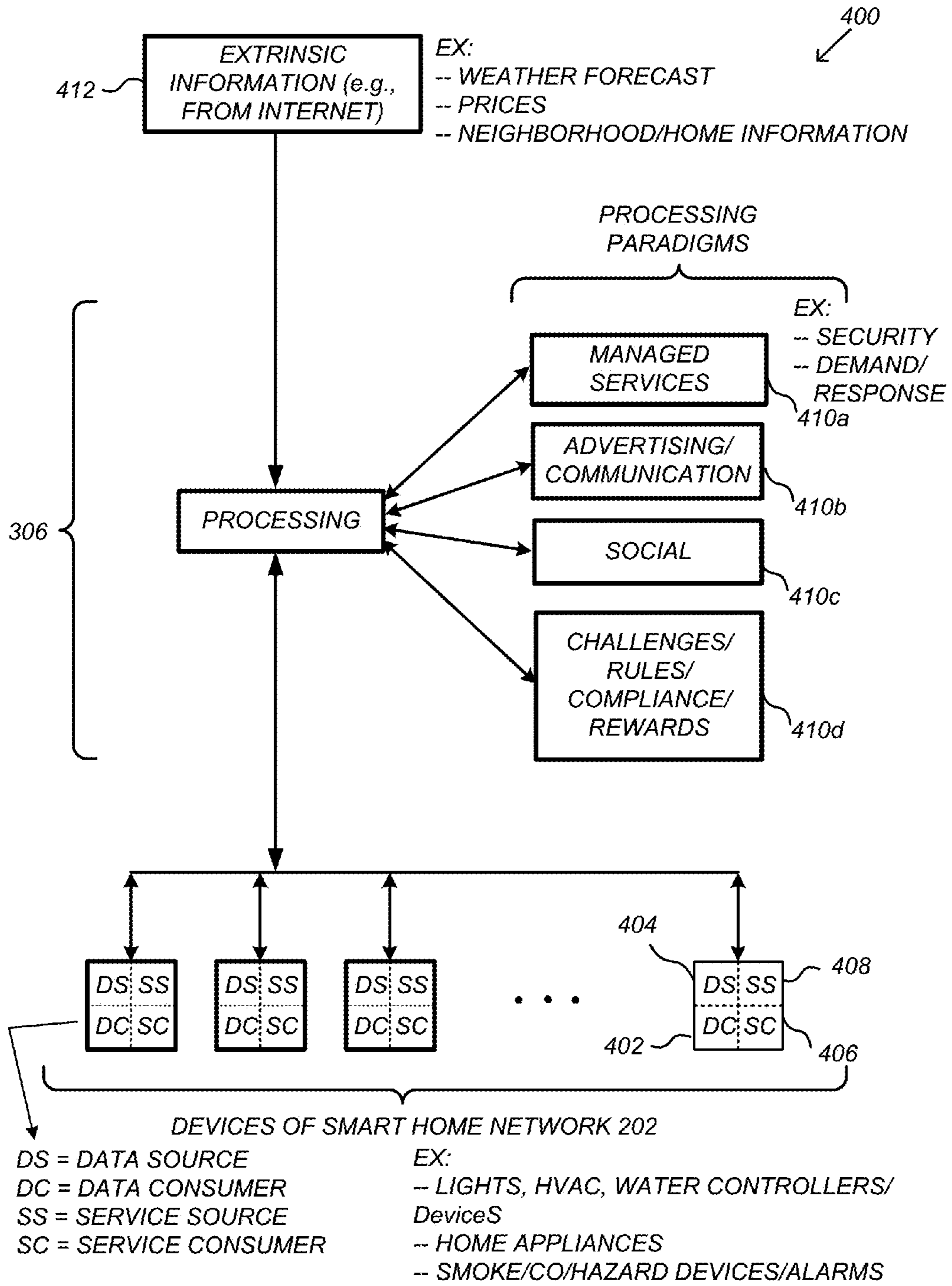

Figure 4

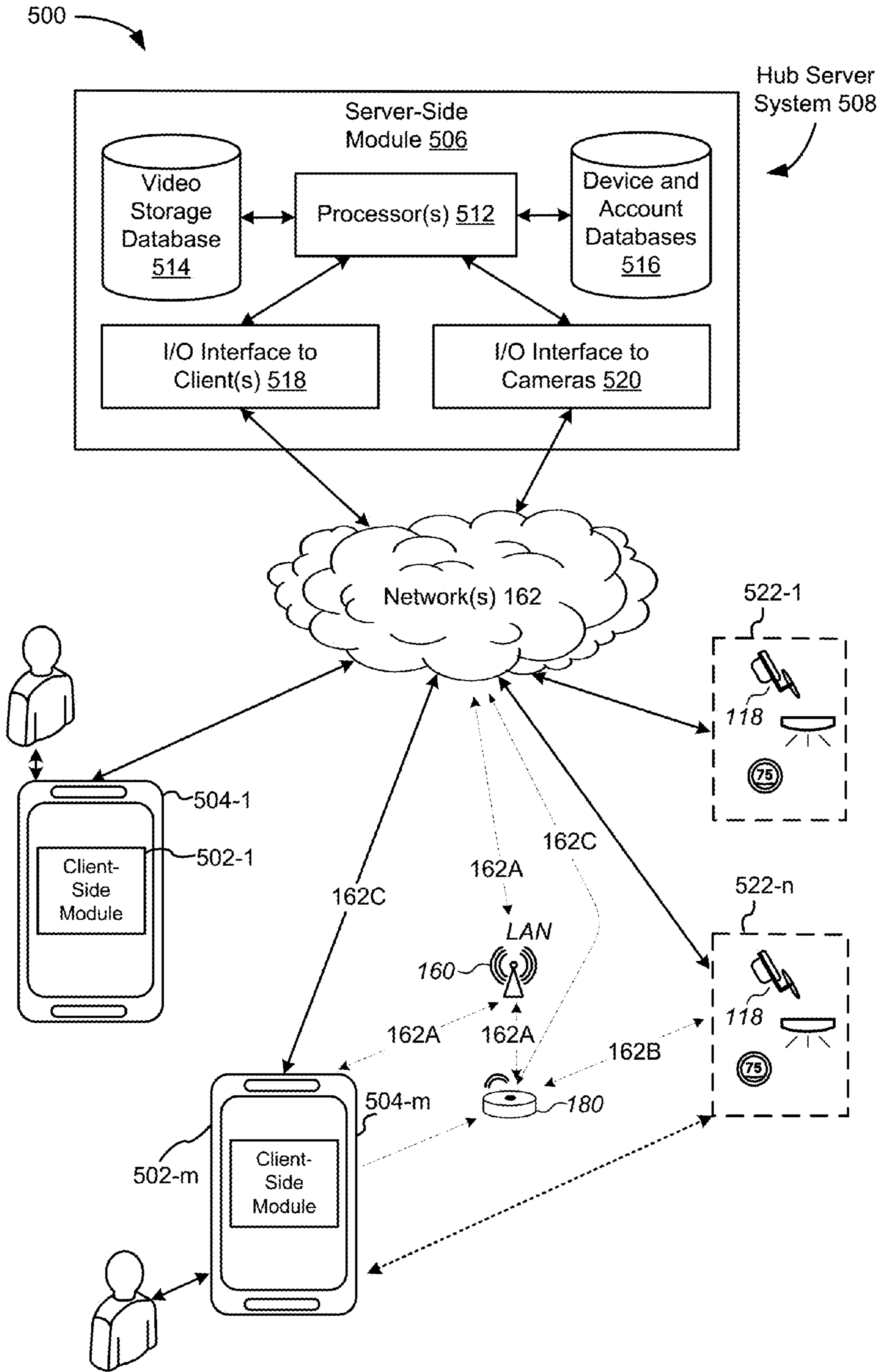

Figure 5



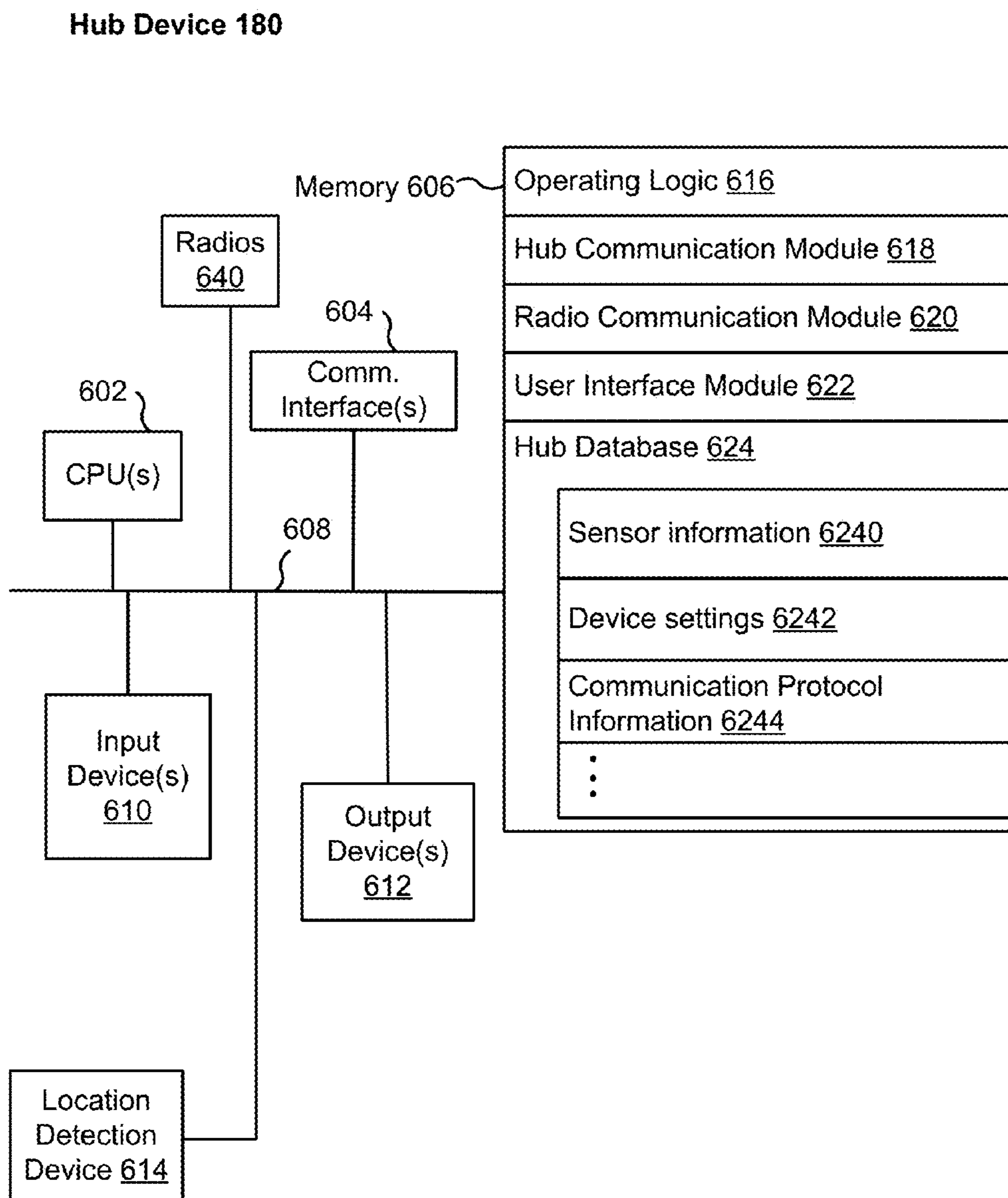

Figure 6

Hub Server System 508

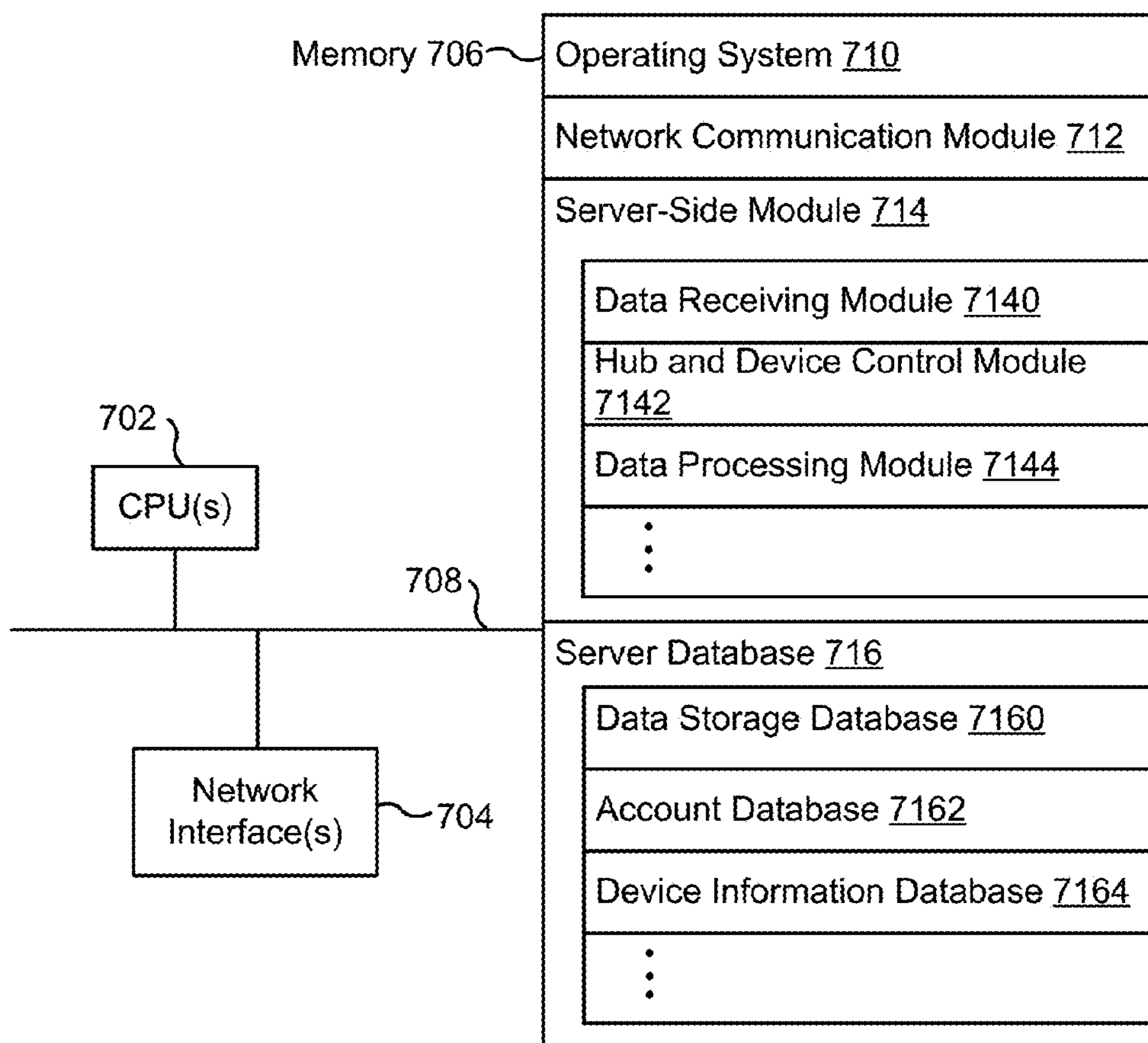
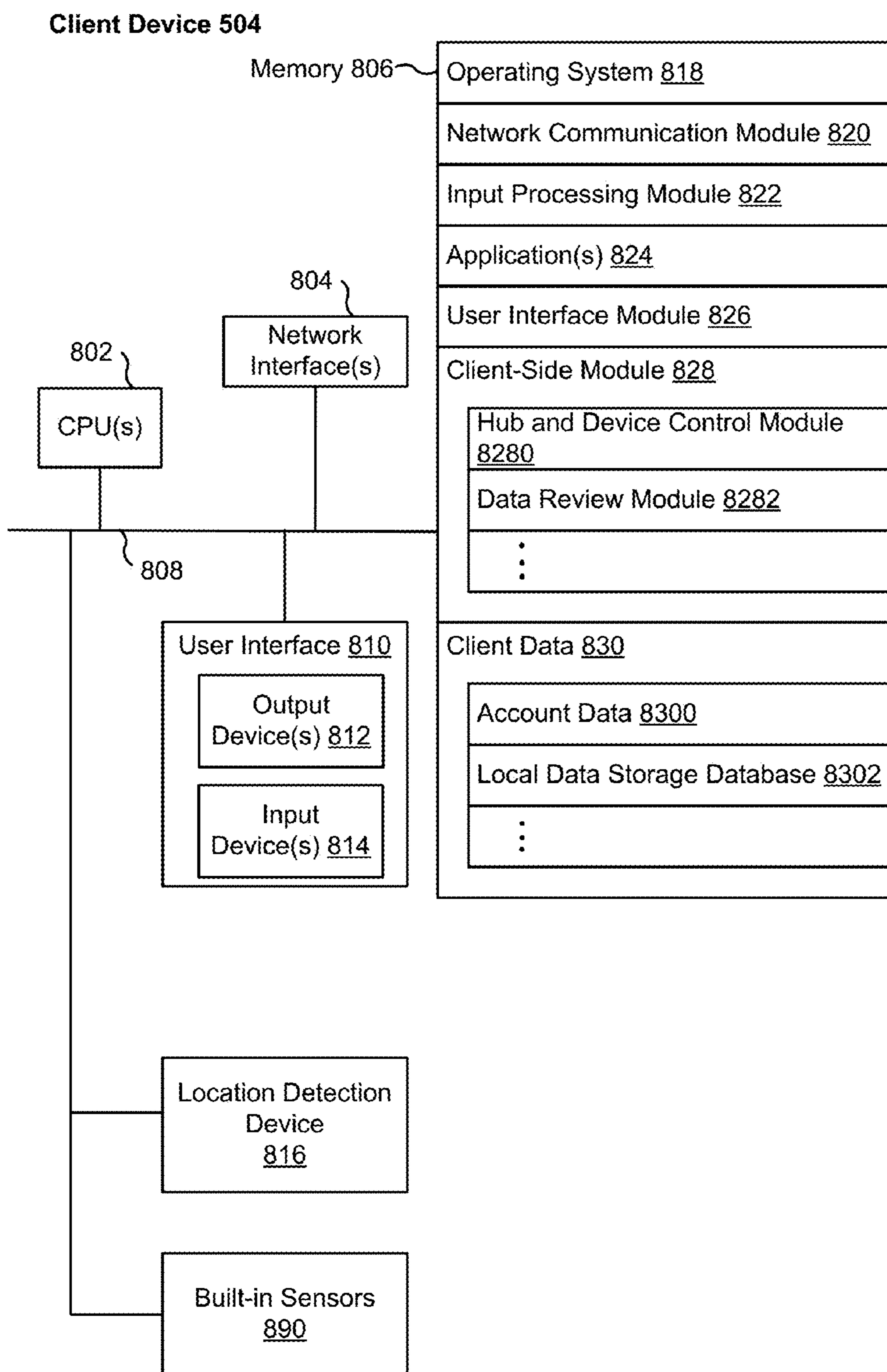

Figure 7



**Figure 8**



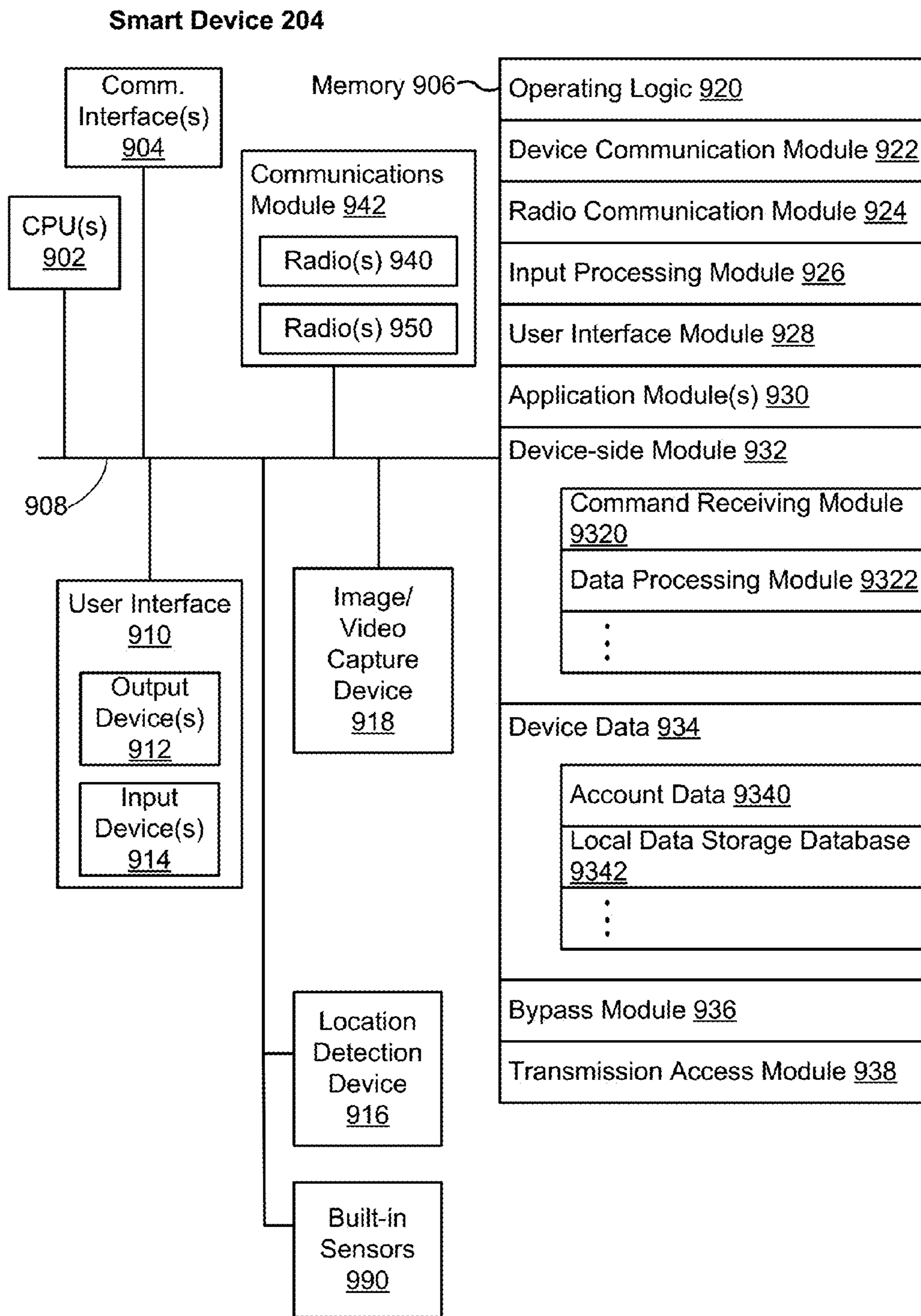

Figure 9

Smart Home Provider  
Server System 164

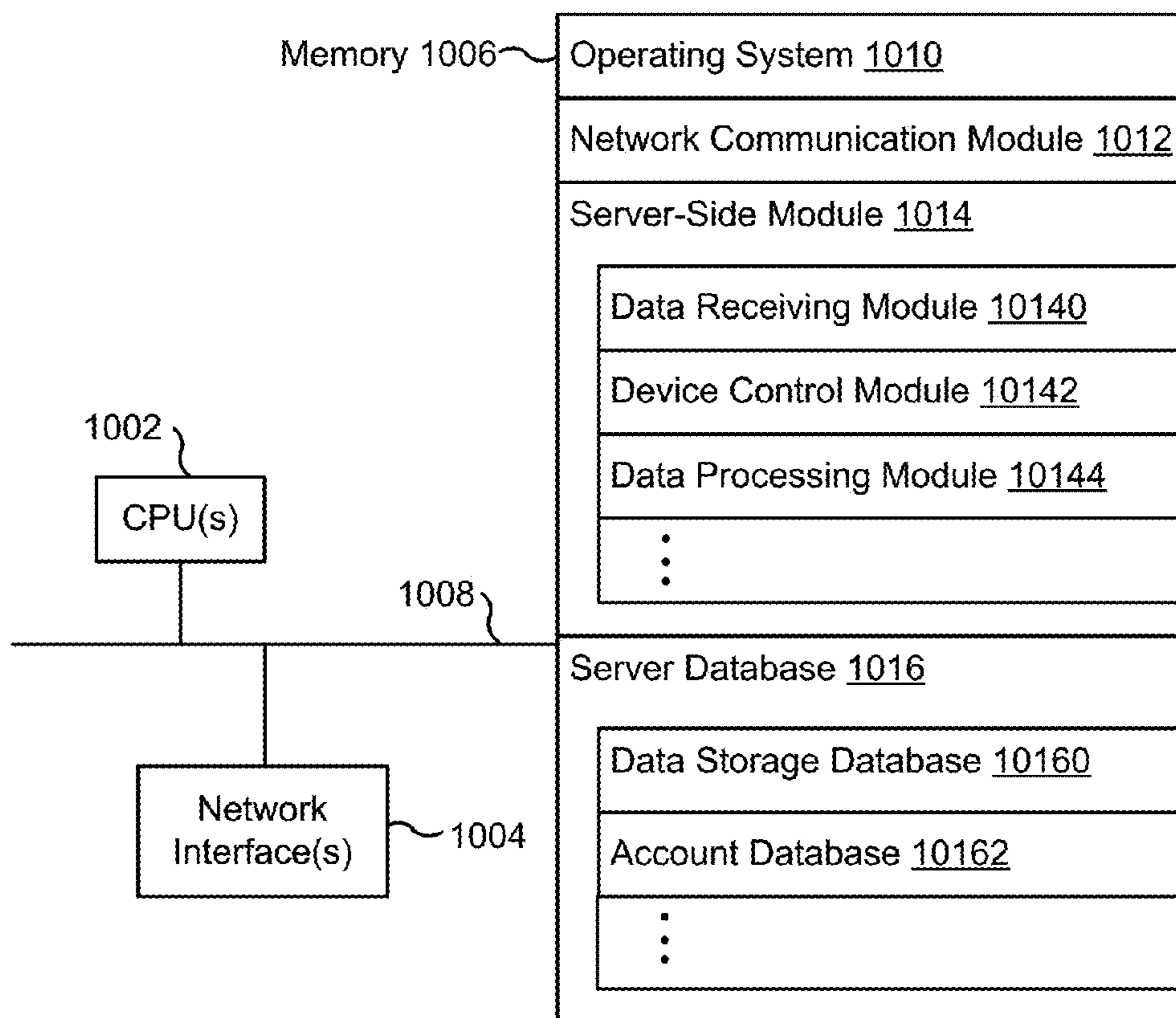

Figure 10

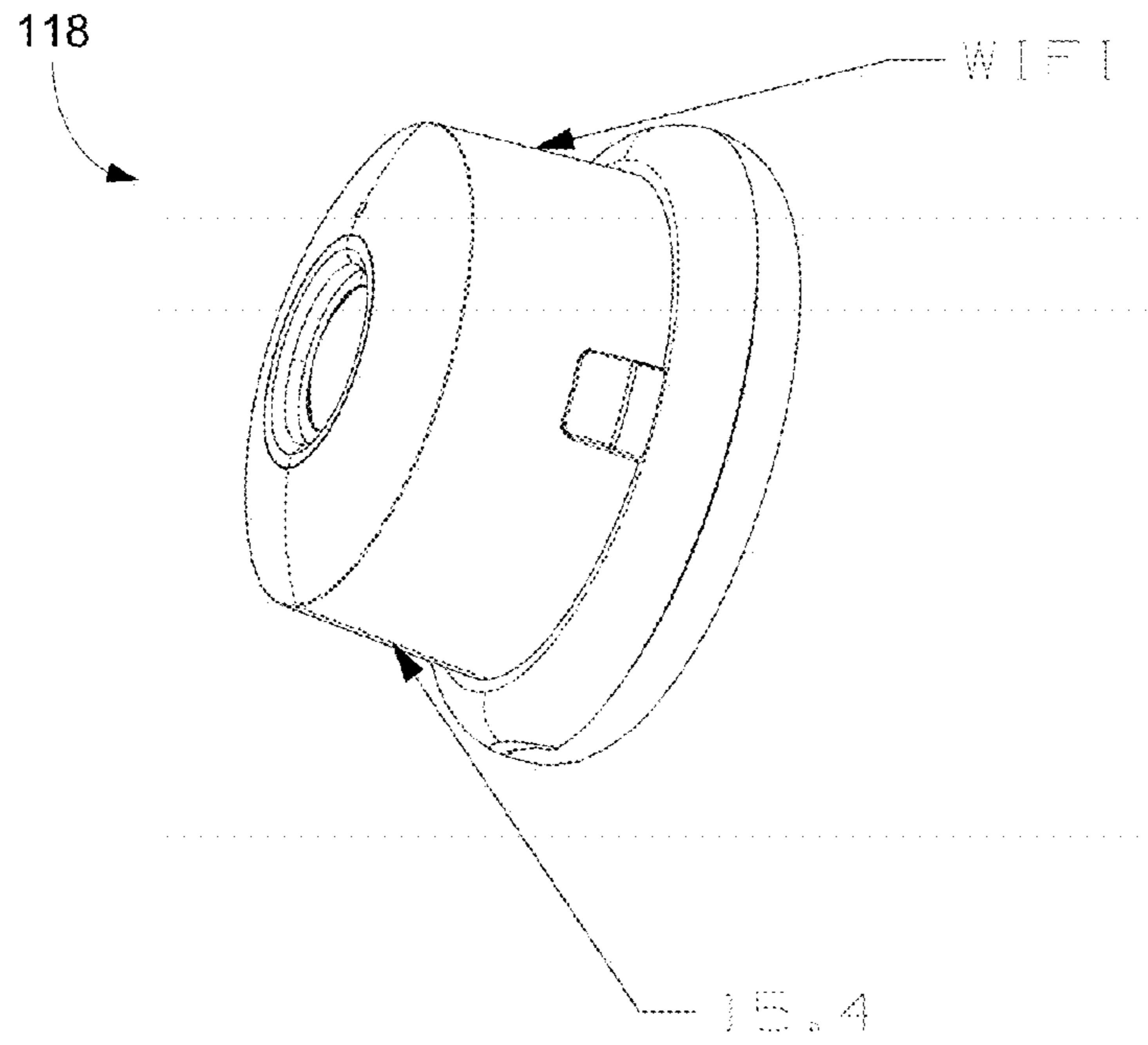

FIGURE 11A

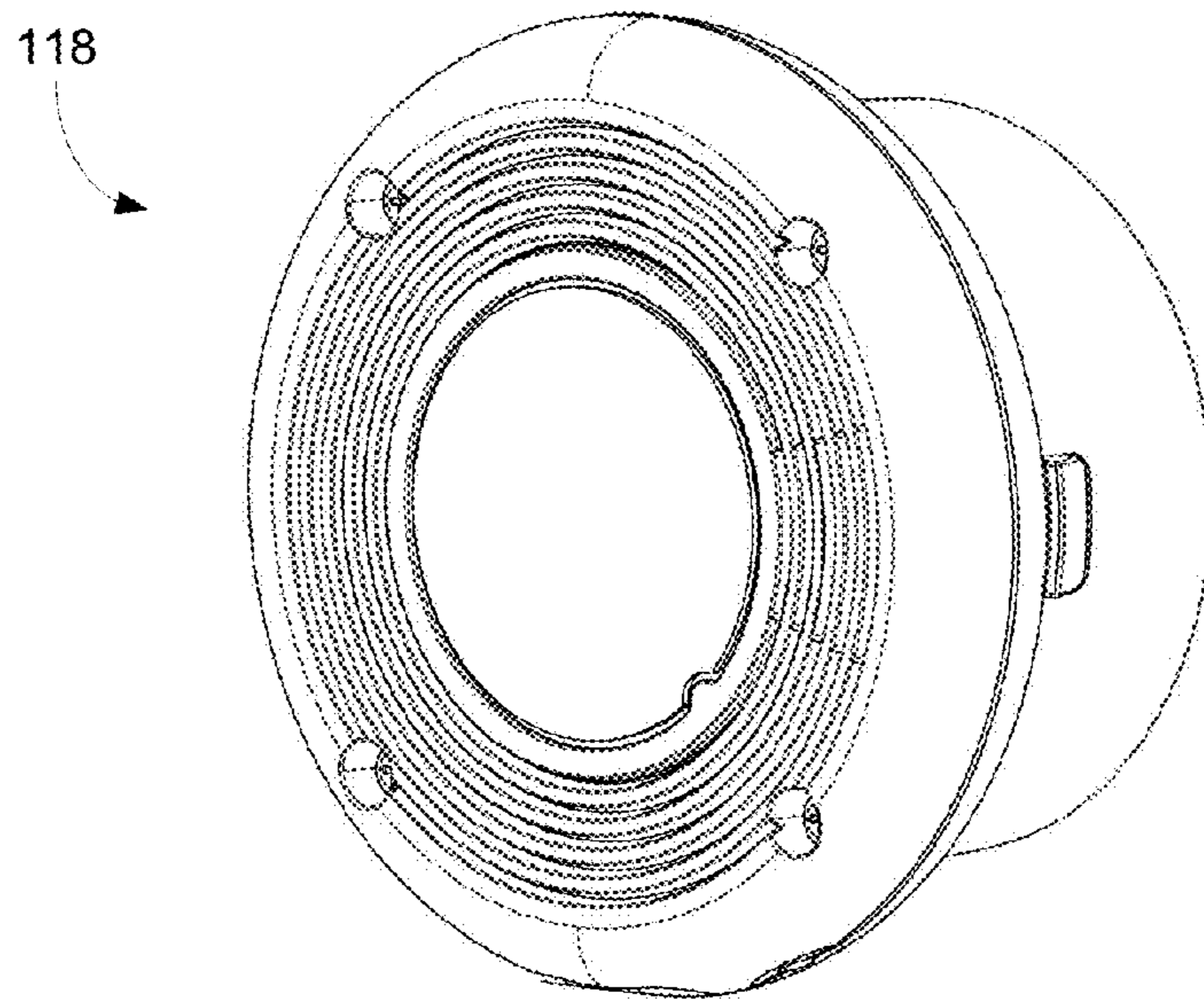

FIGURE 11B



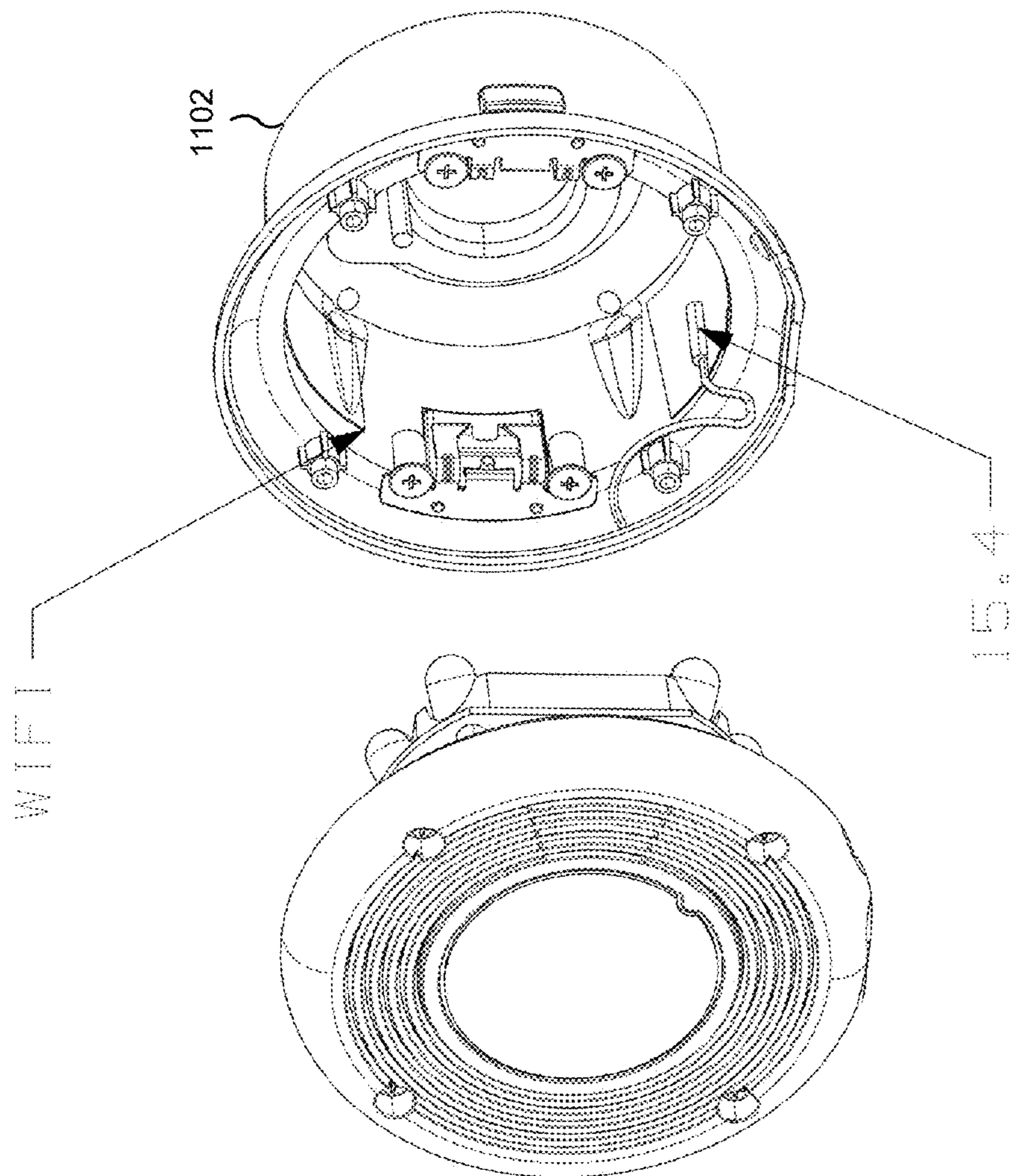
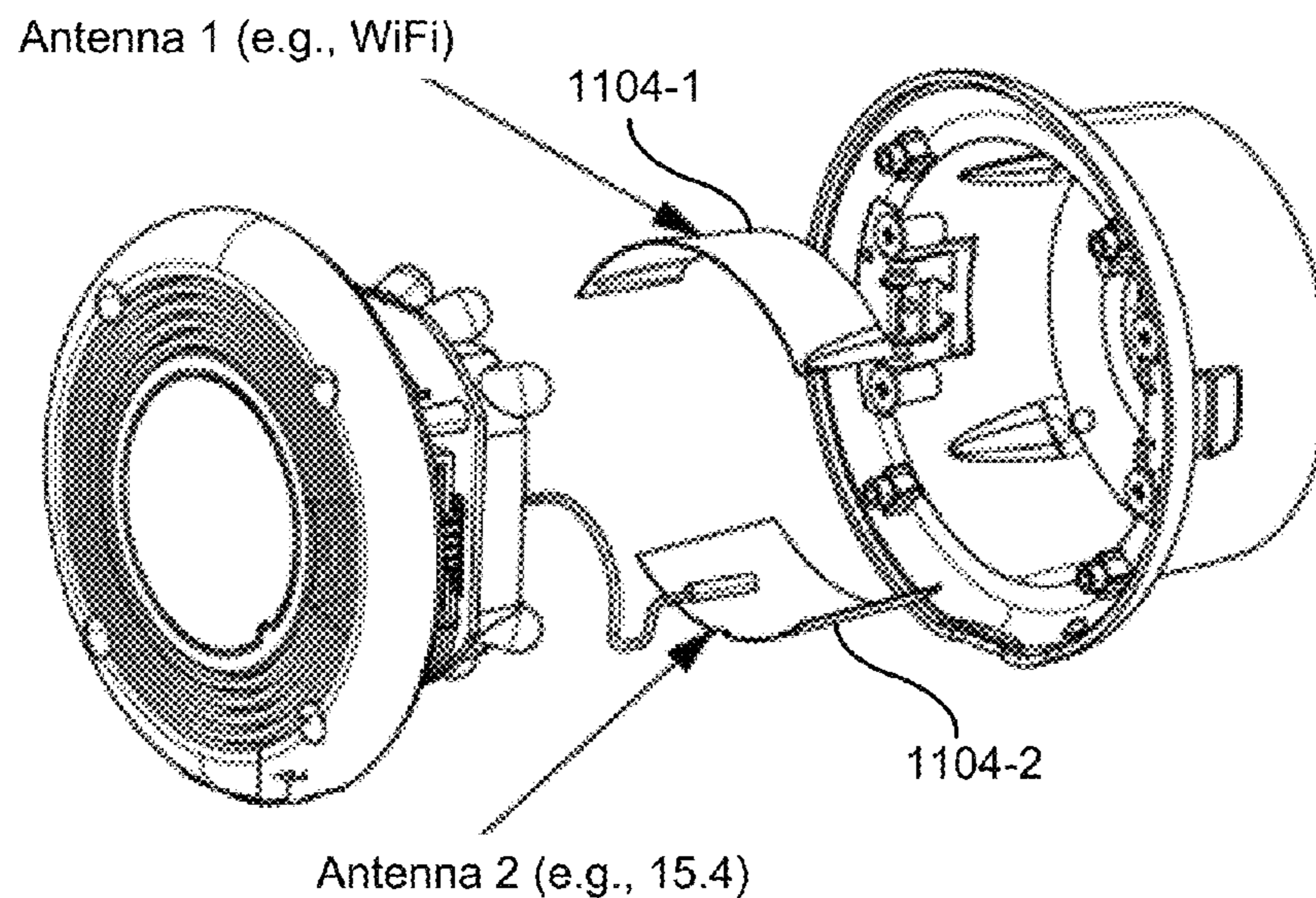
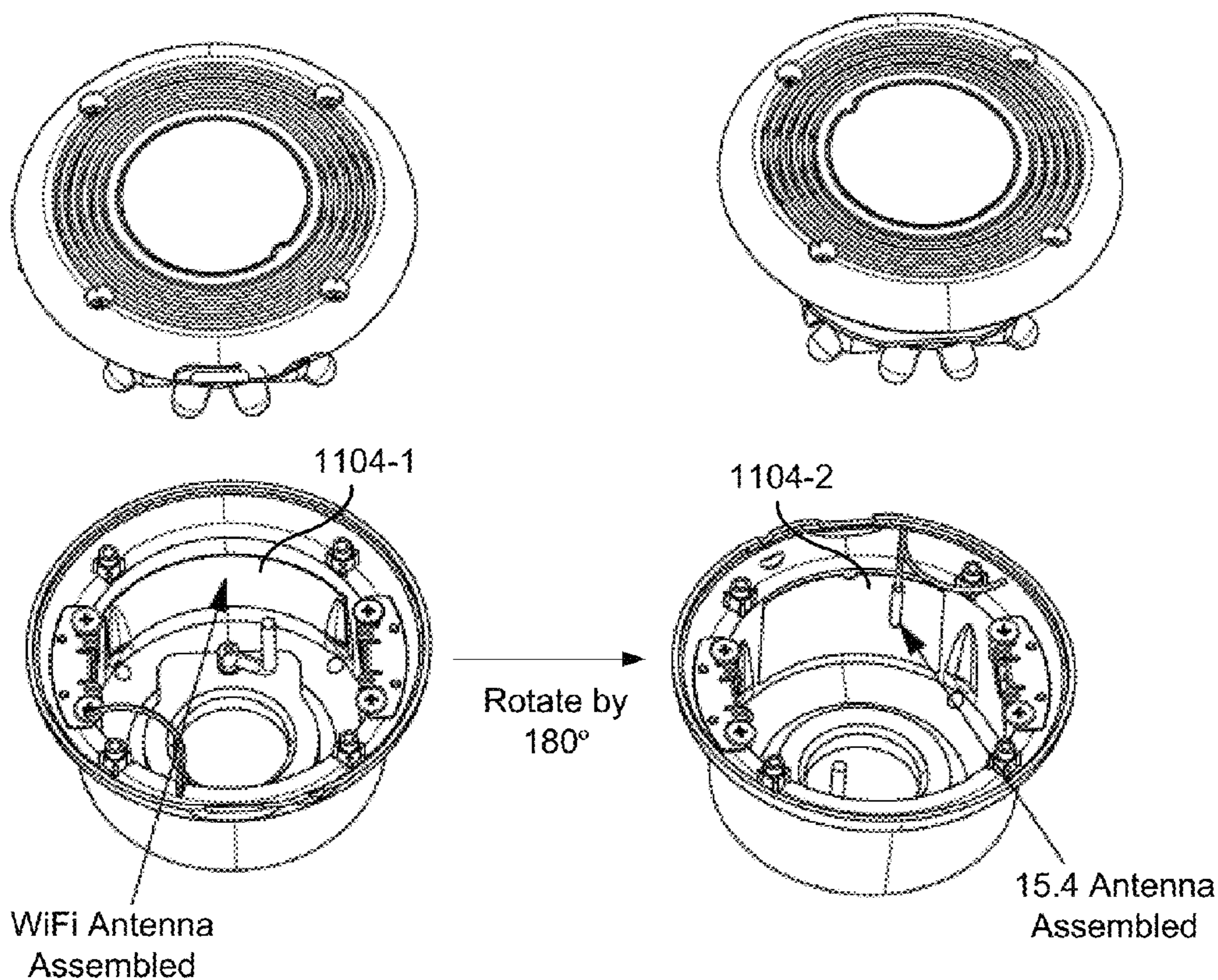

FIGURE 11C



**FIGURE 11D**



Antenna Placement inside  
the Camera Module

**FIGURE 11E**



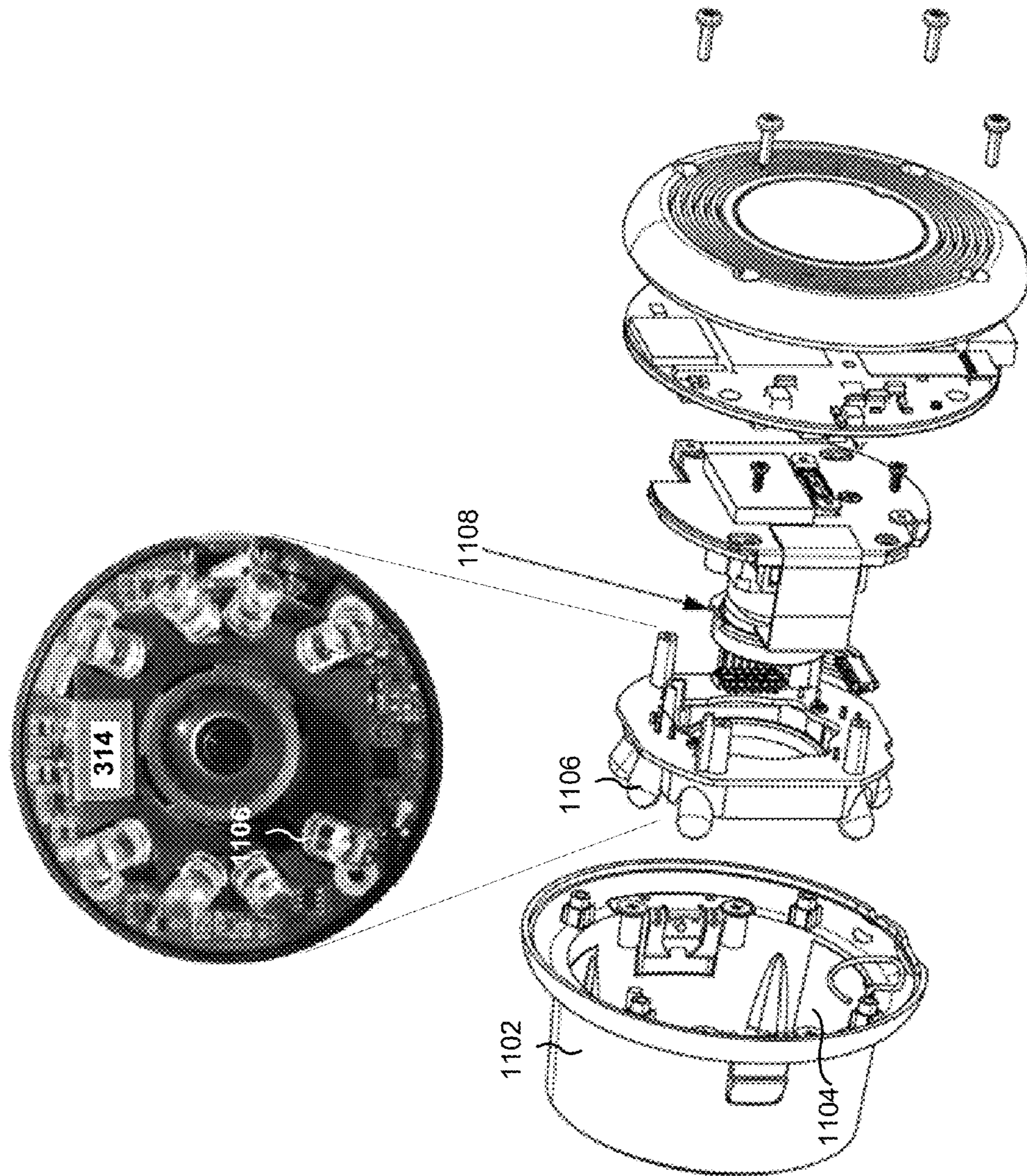

FIGURE 11F

118



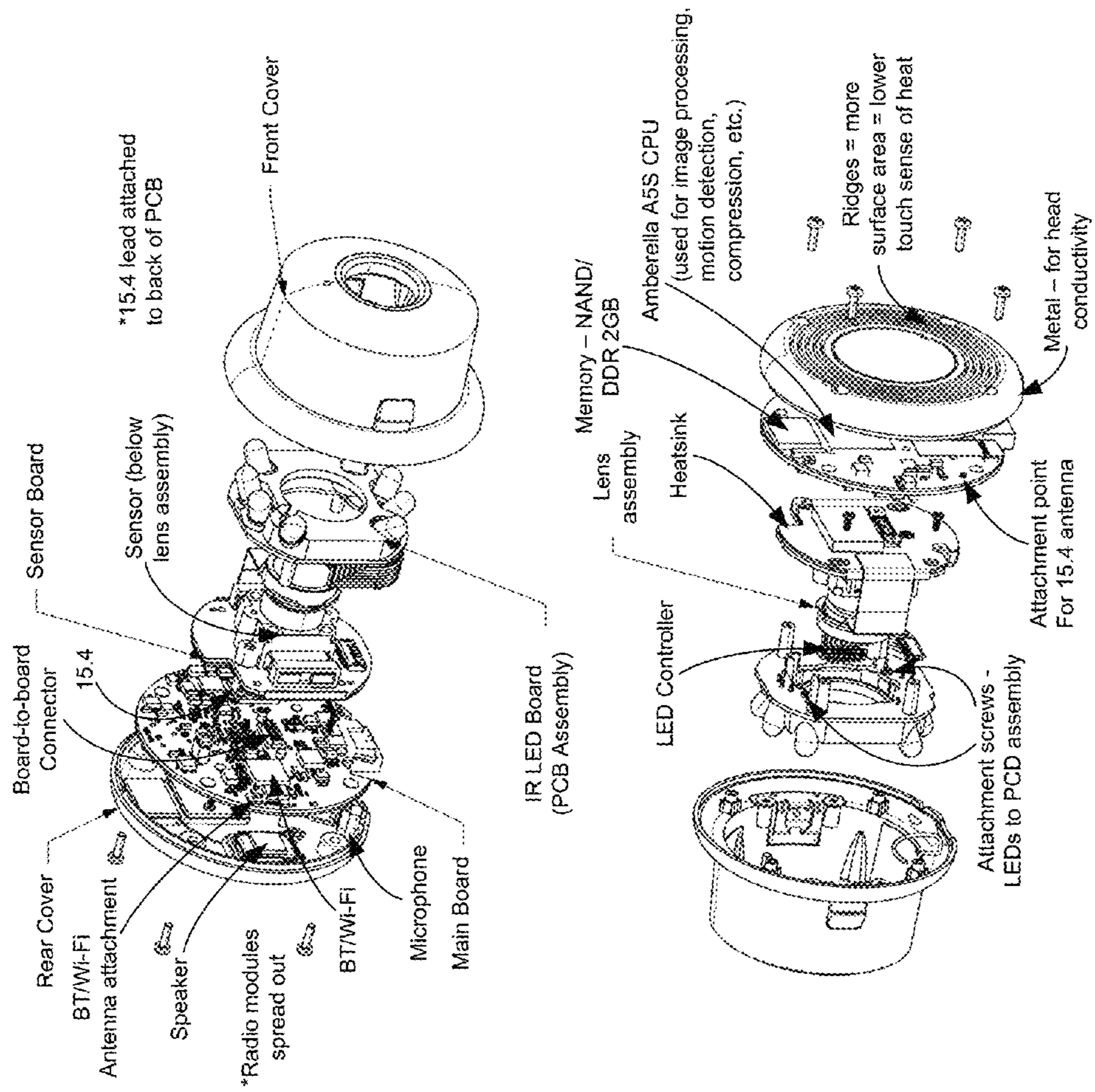

FIGURE 11G

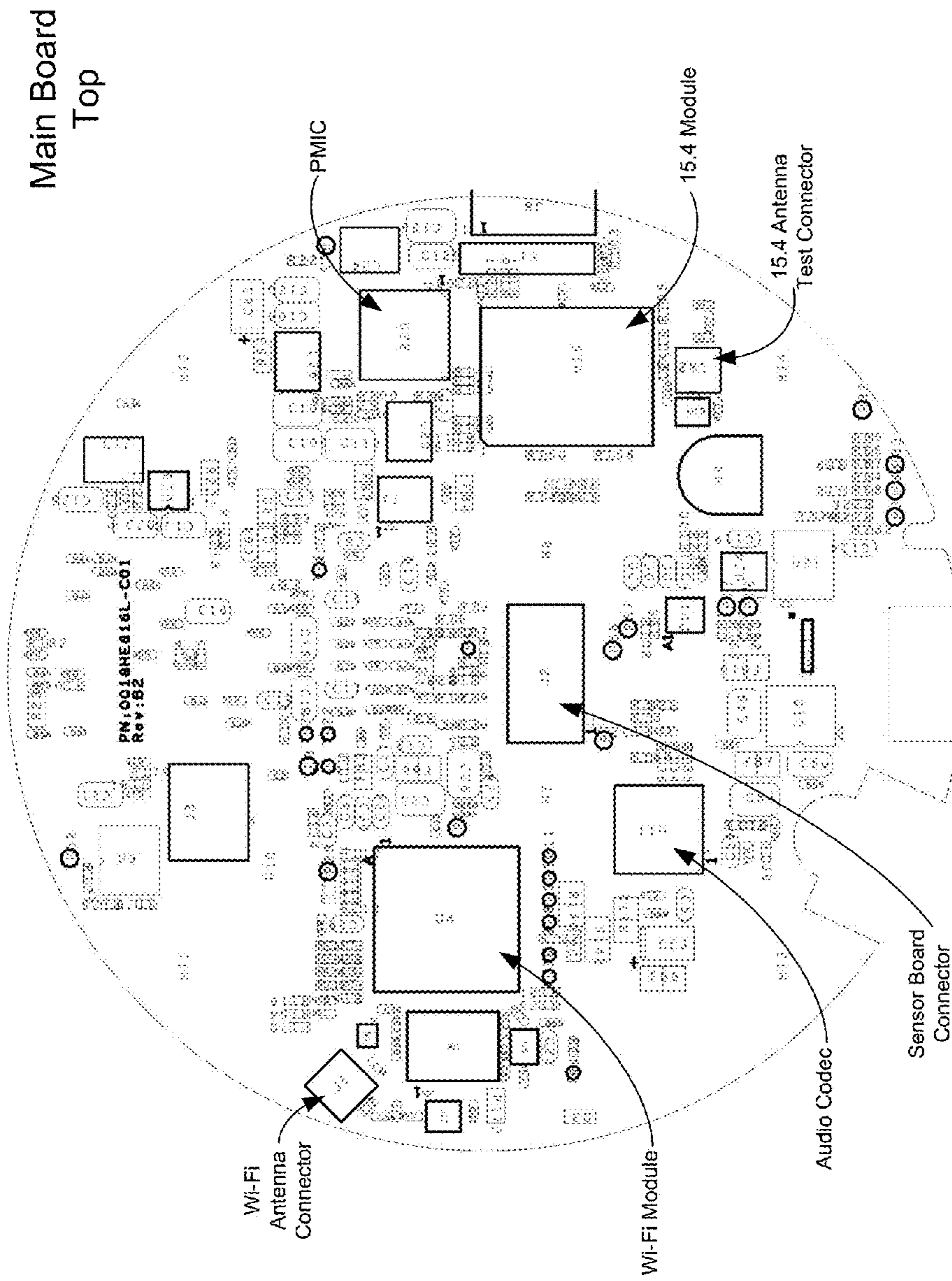

FIGURE 11H

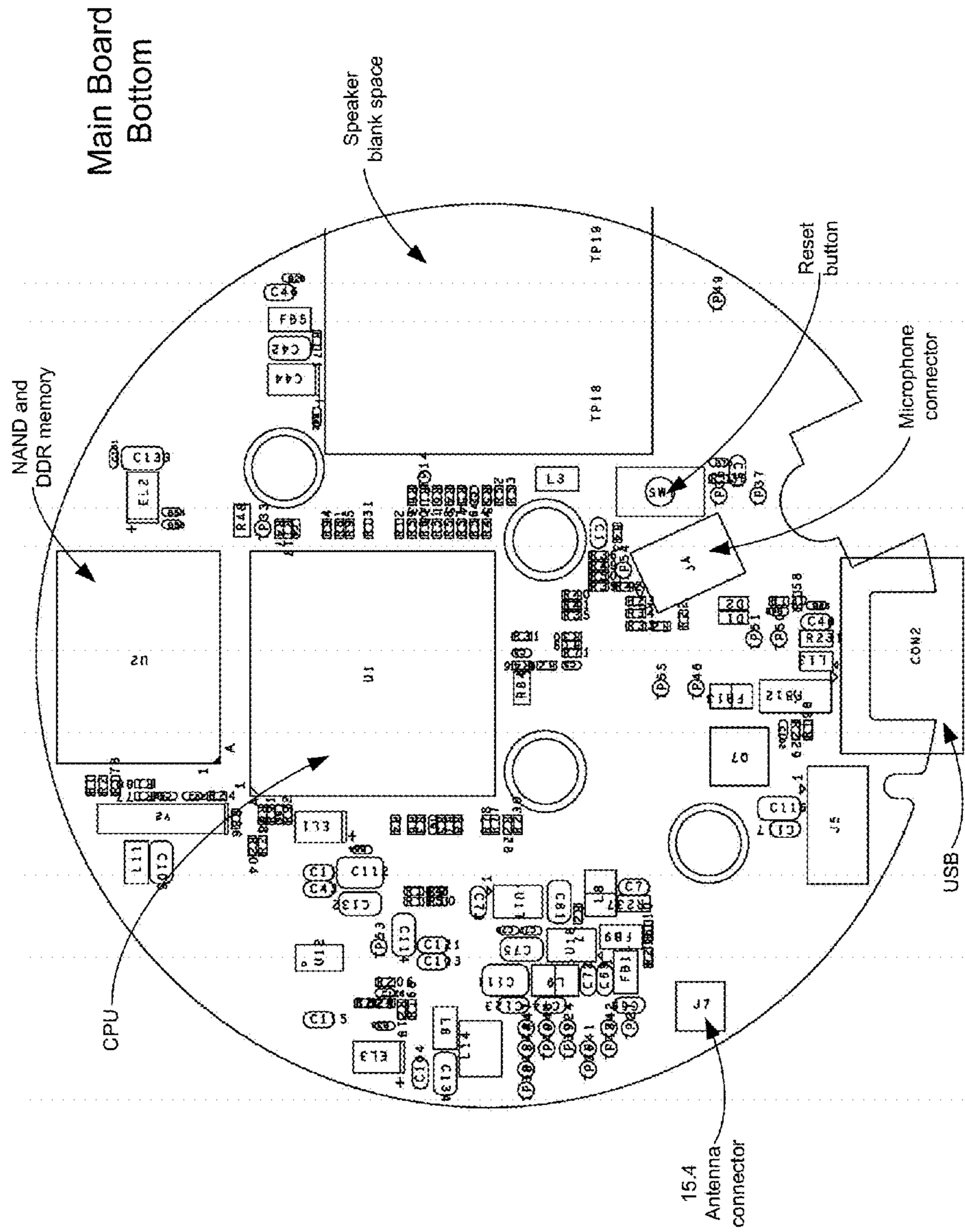

FIGURE 11I



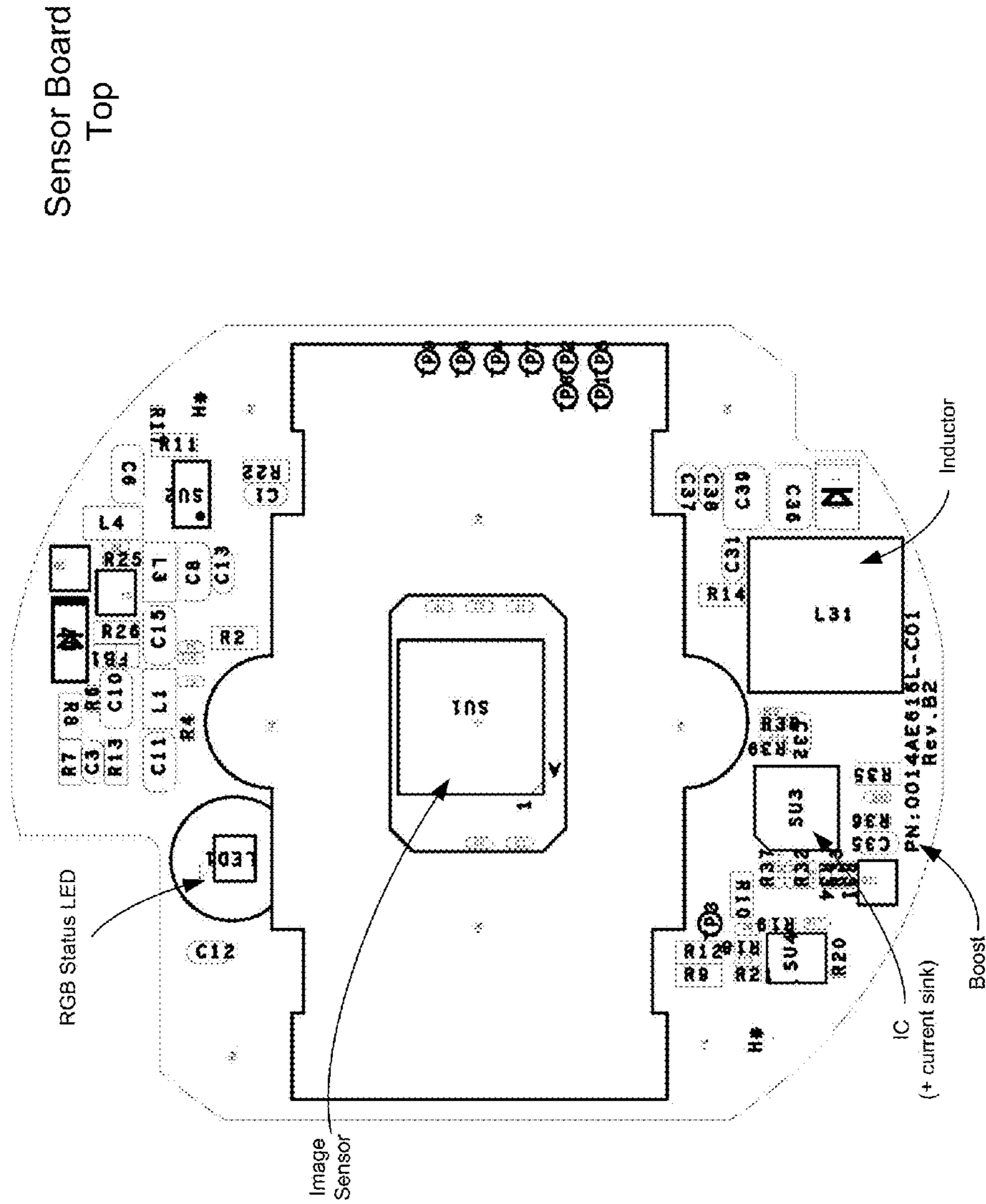

FIGURE 11J

Sensor Board  
Bottom

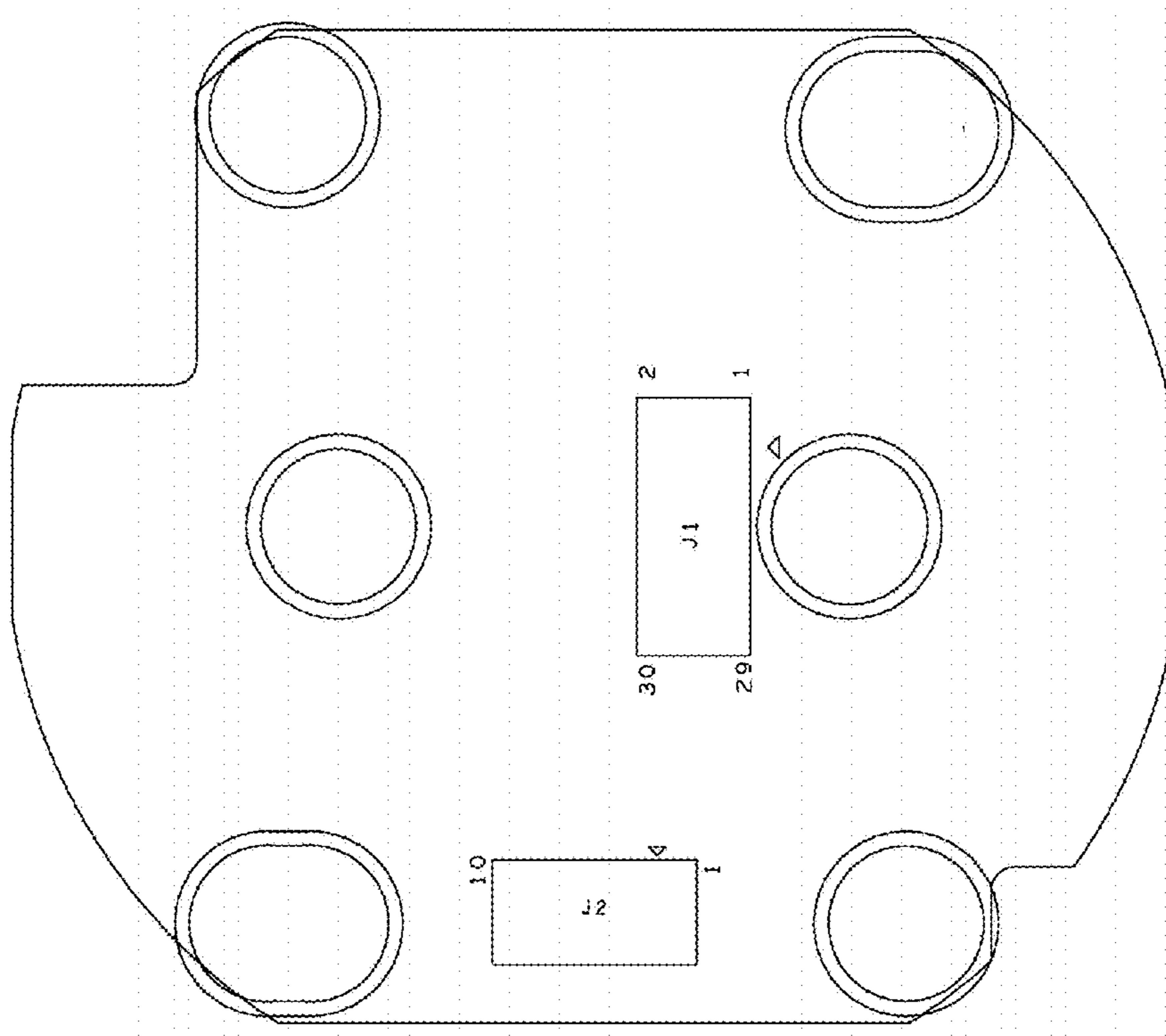

FIGURE 11K

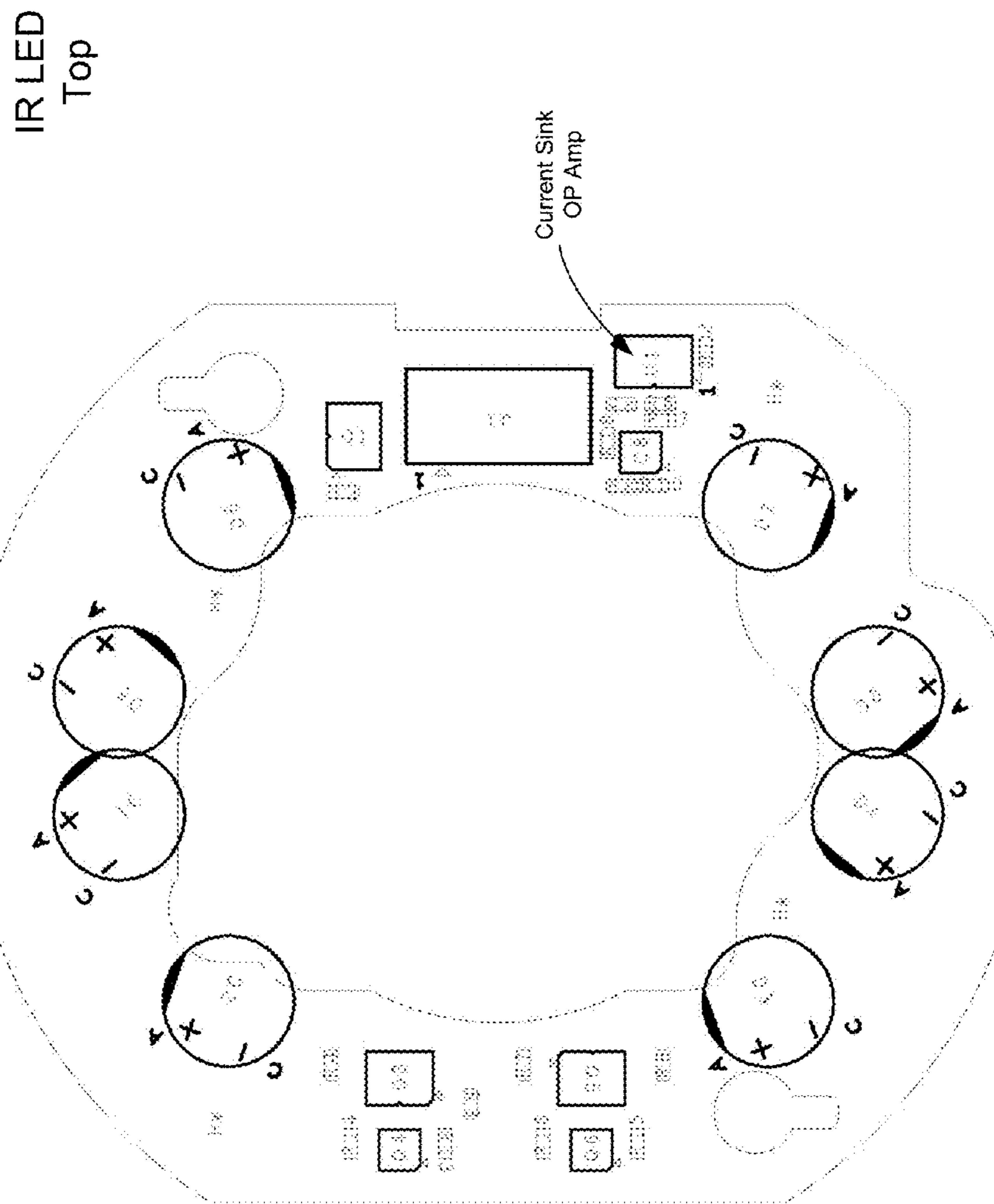

FIGURE 11L



IR LED  
Bottom

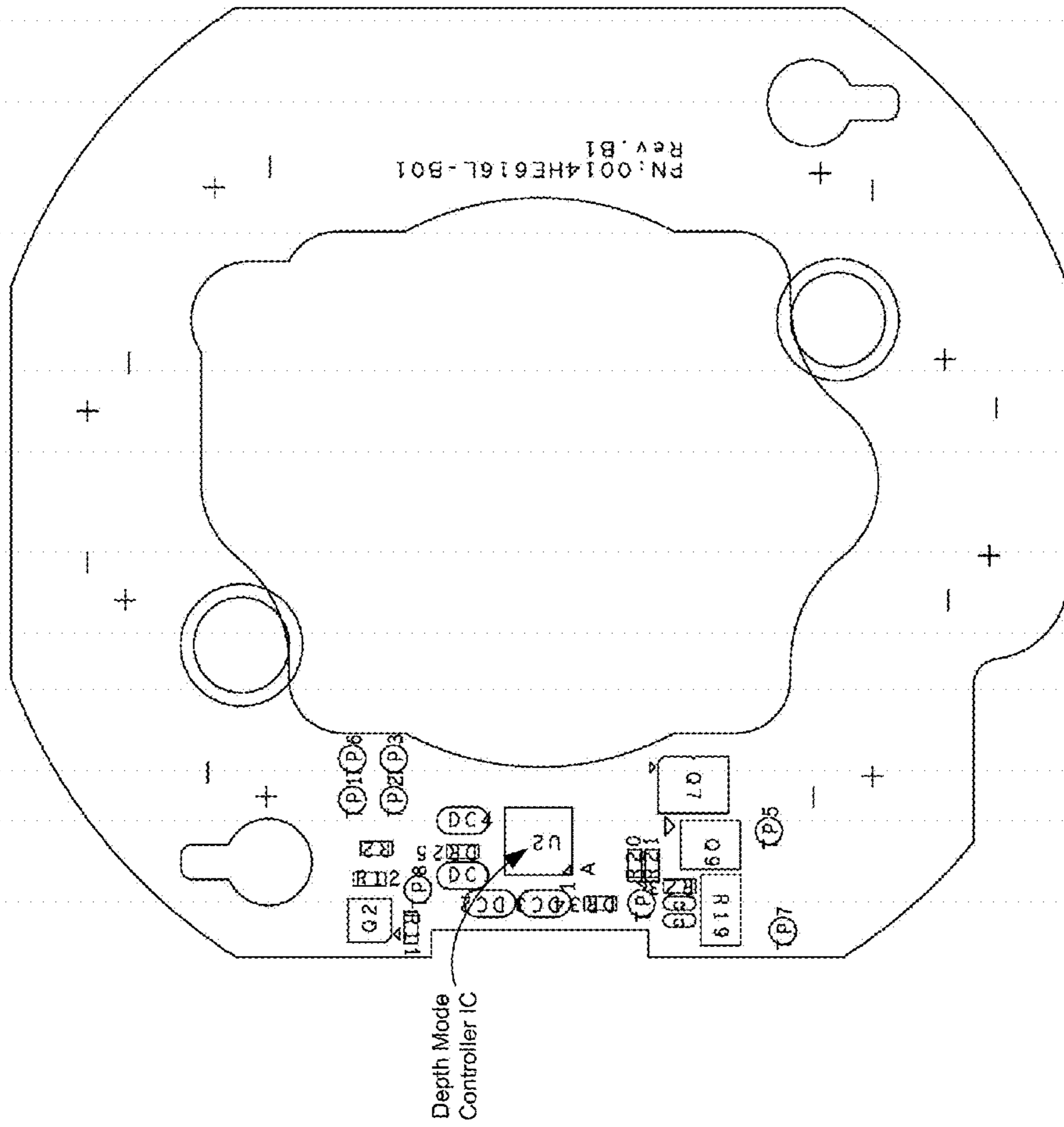

FIGURE 11M

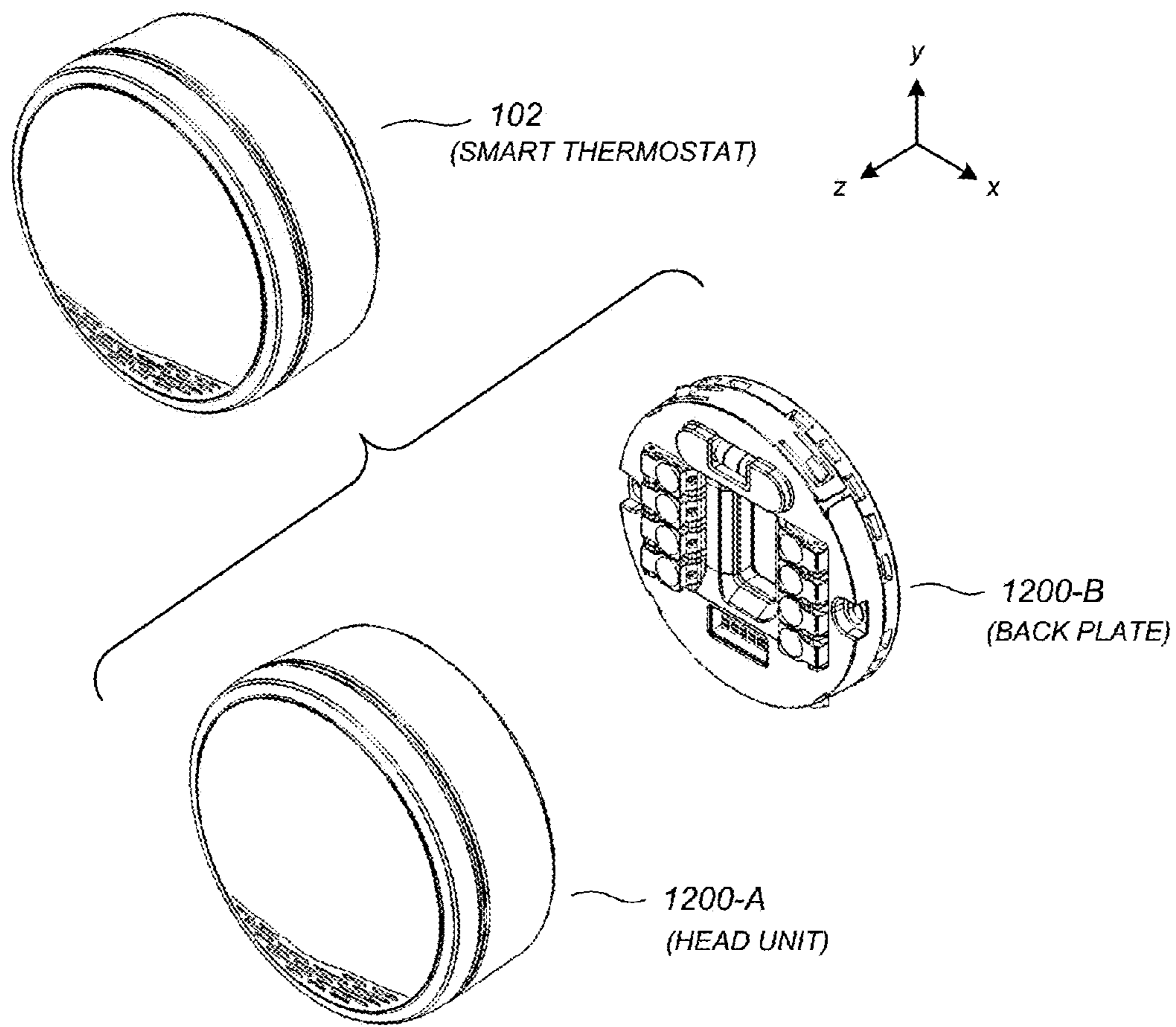

FIGURE 12A

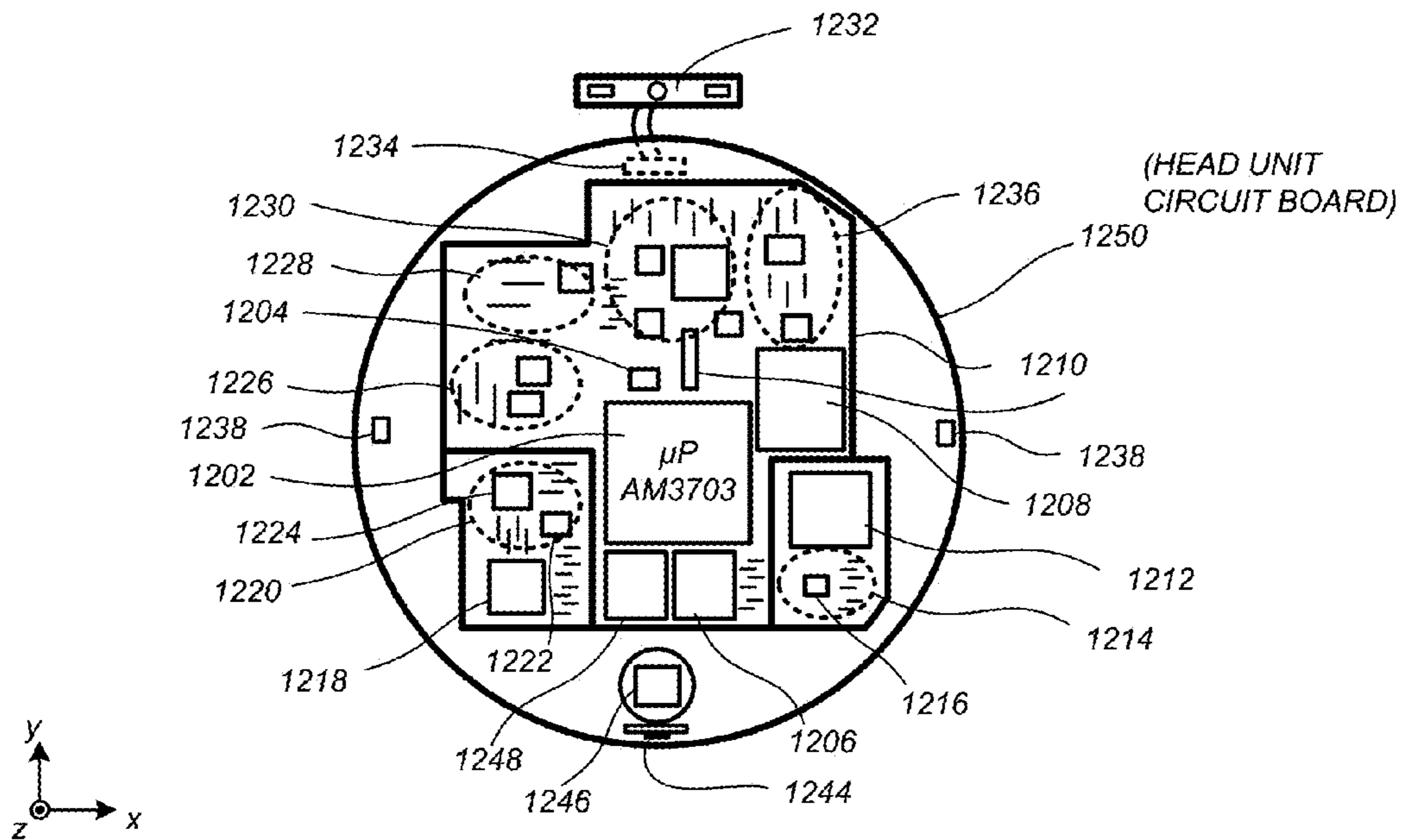

FIGURE 12B

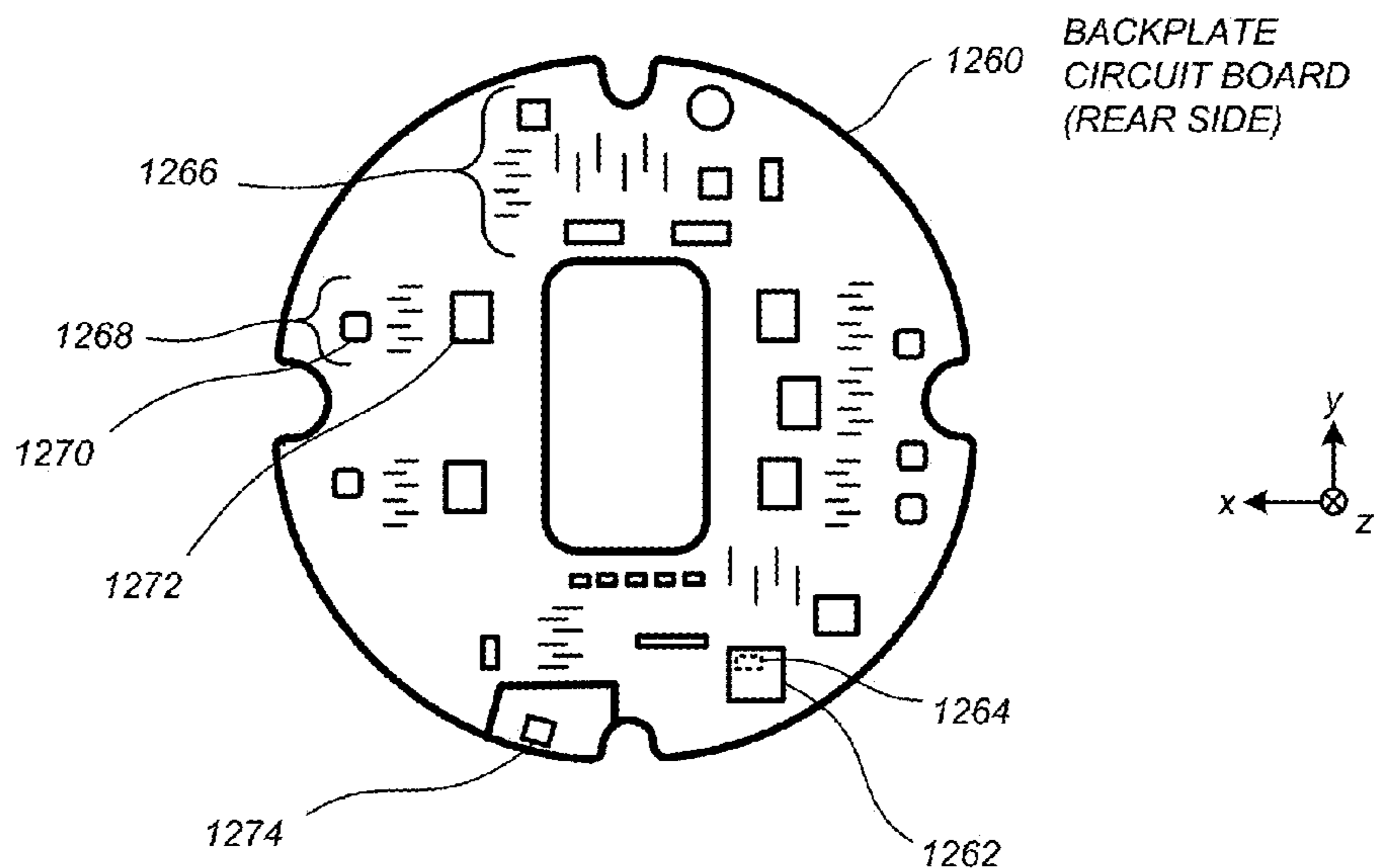
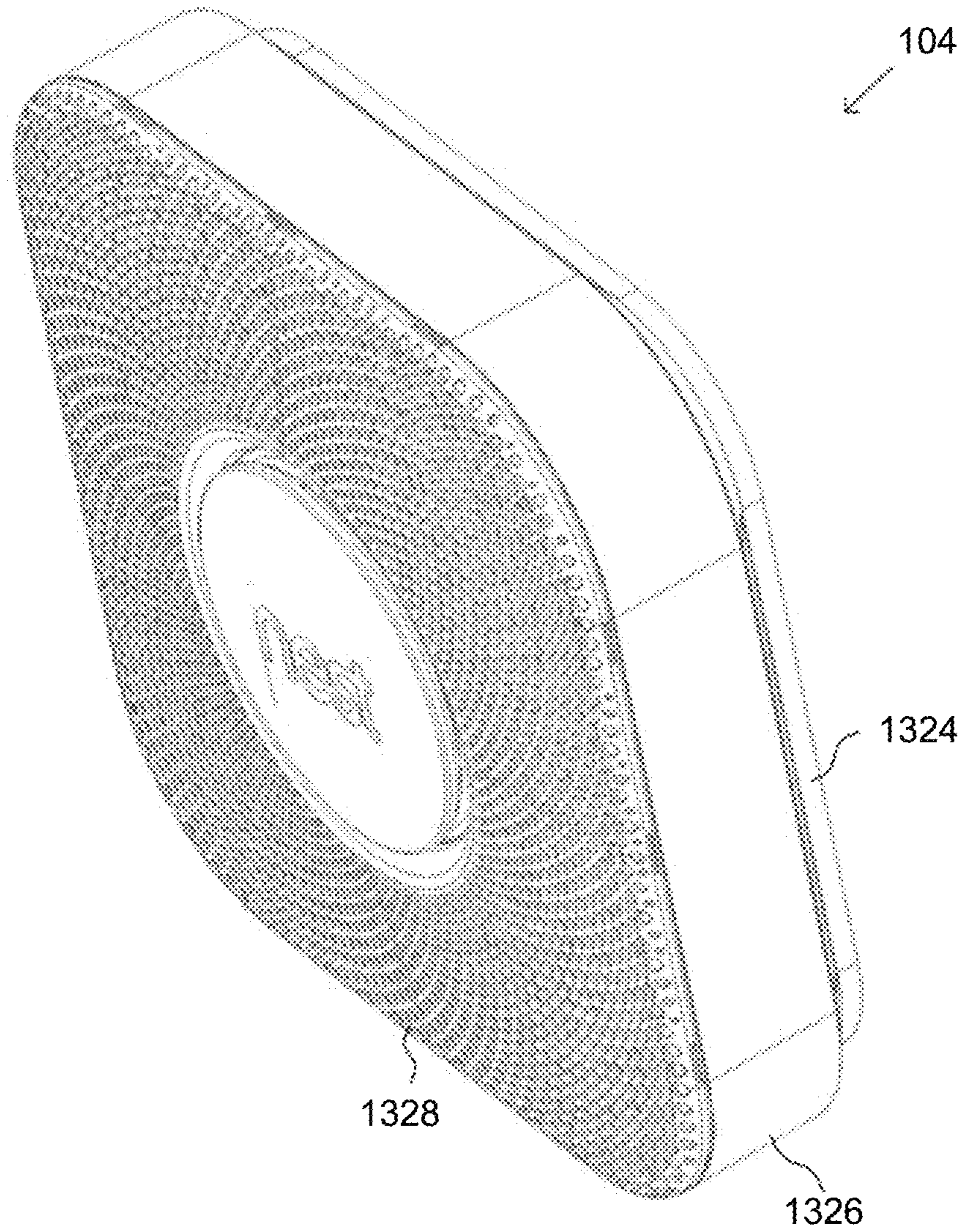

FIGURE 12C





**FIGURE 13A**

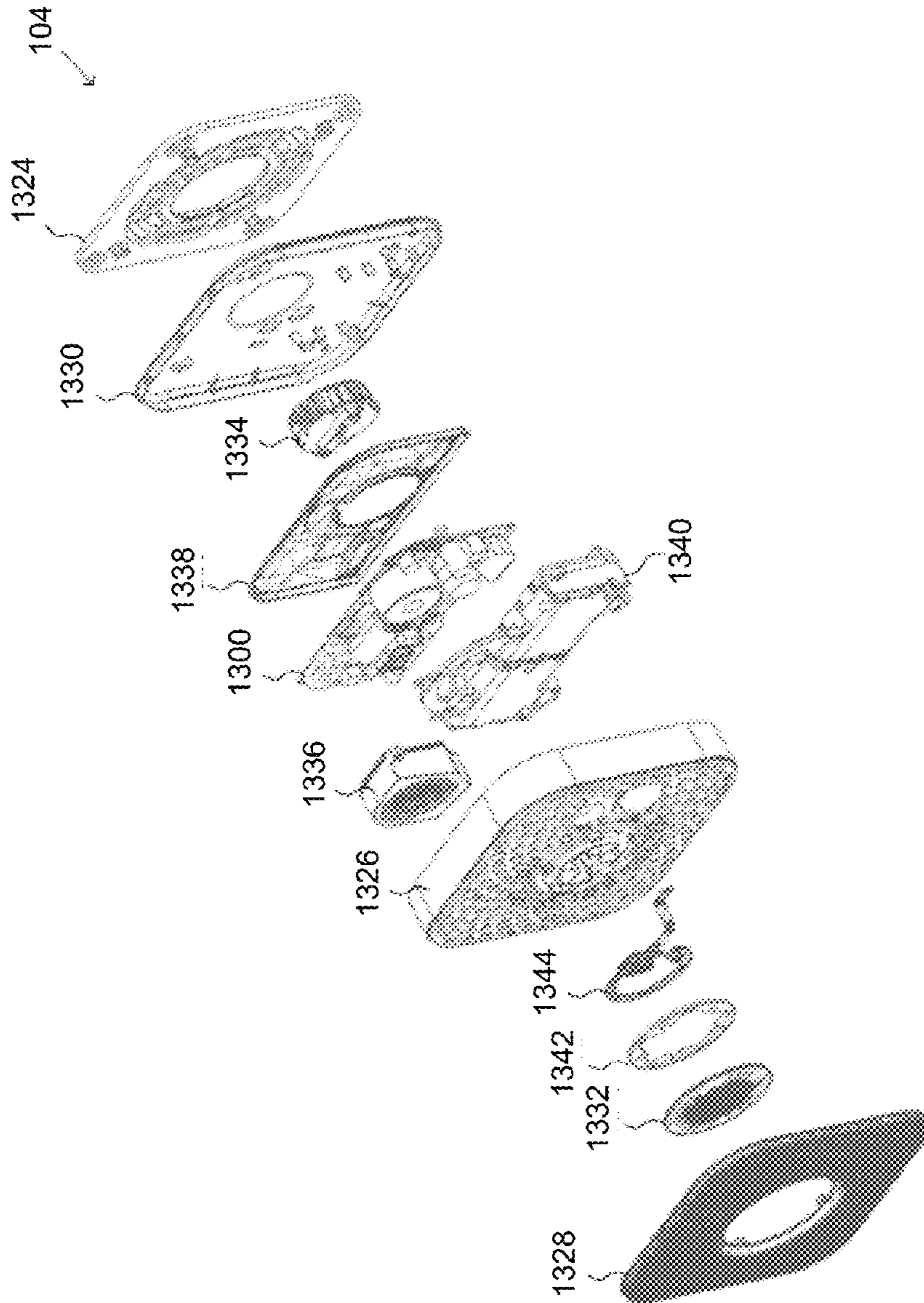

FIGURE 13B



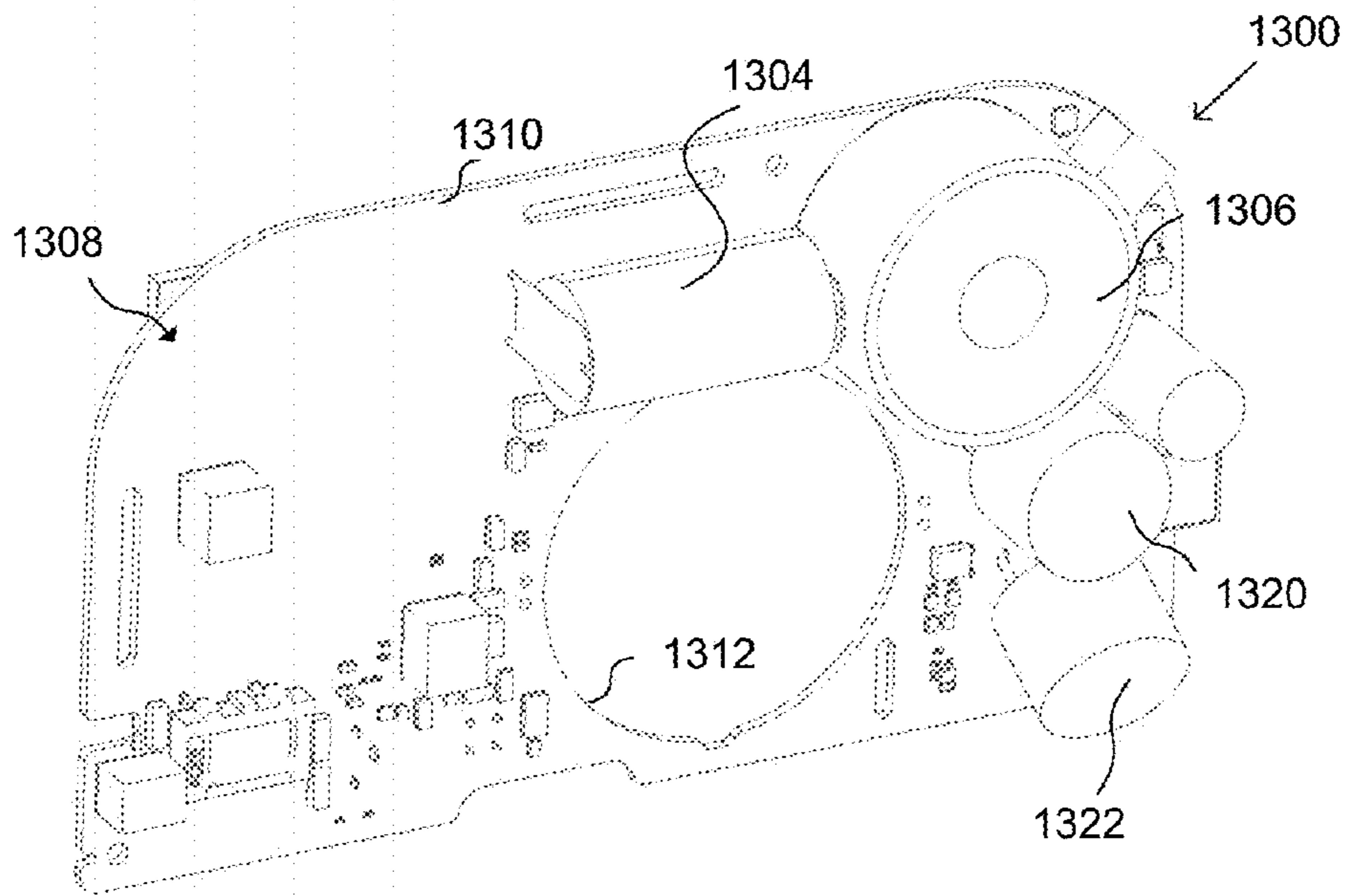

FIGURE 13C

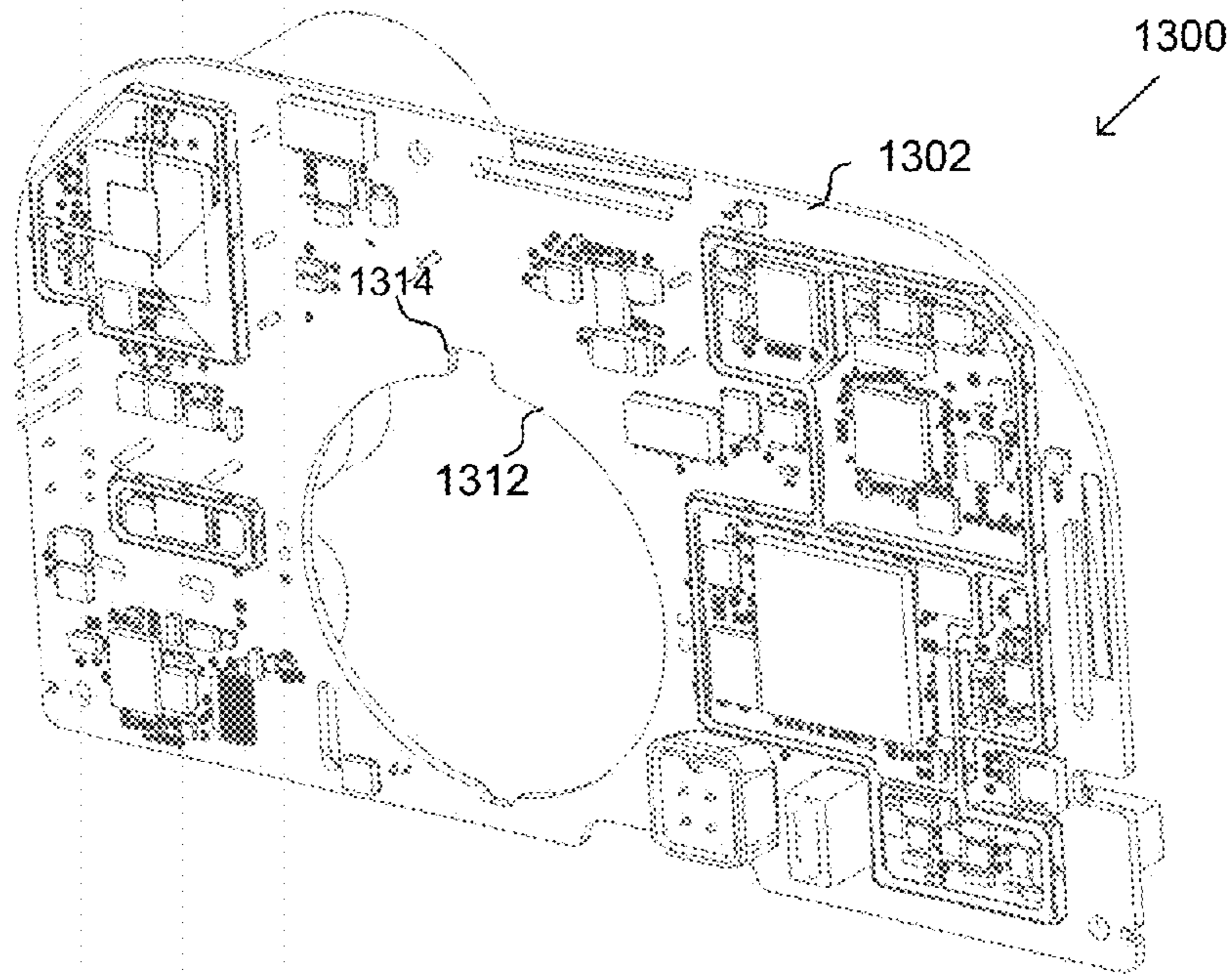

FIGURE 13D



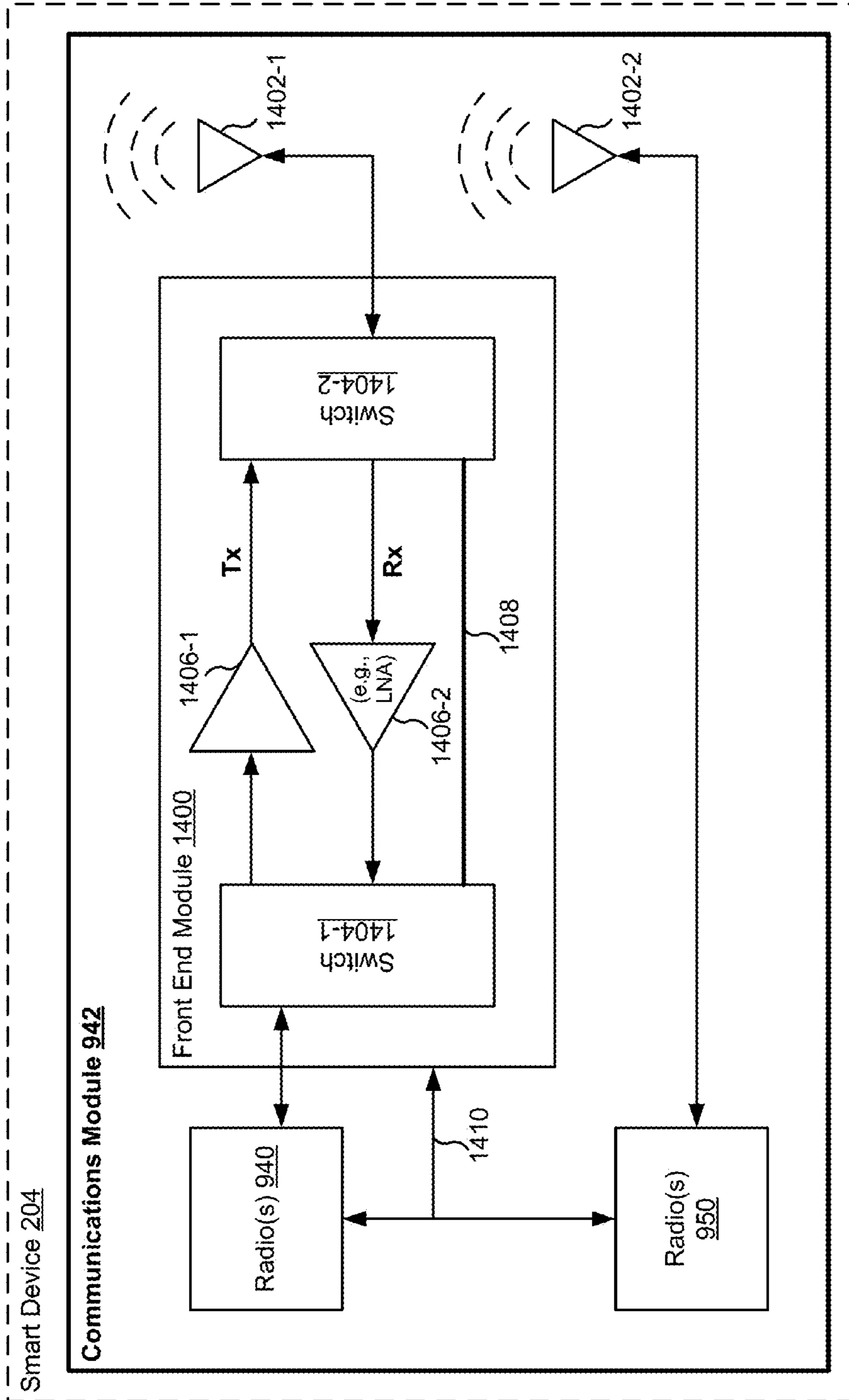

FIGURE 14

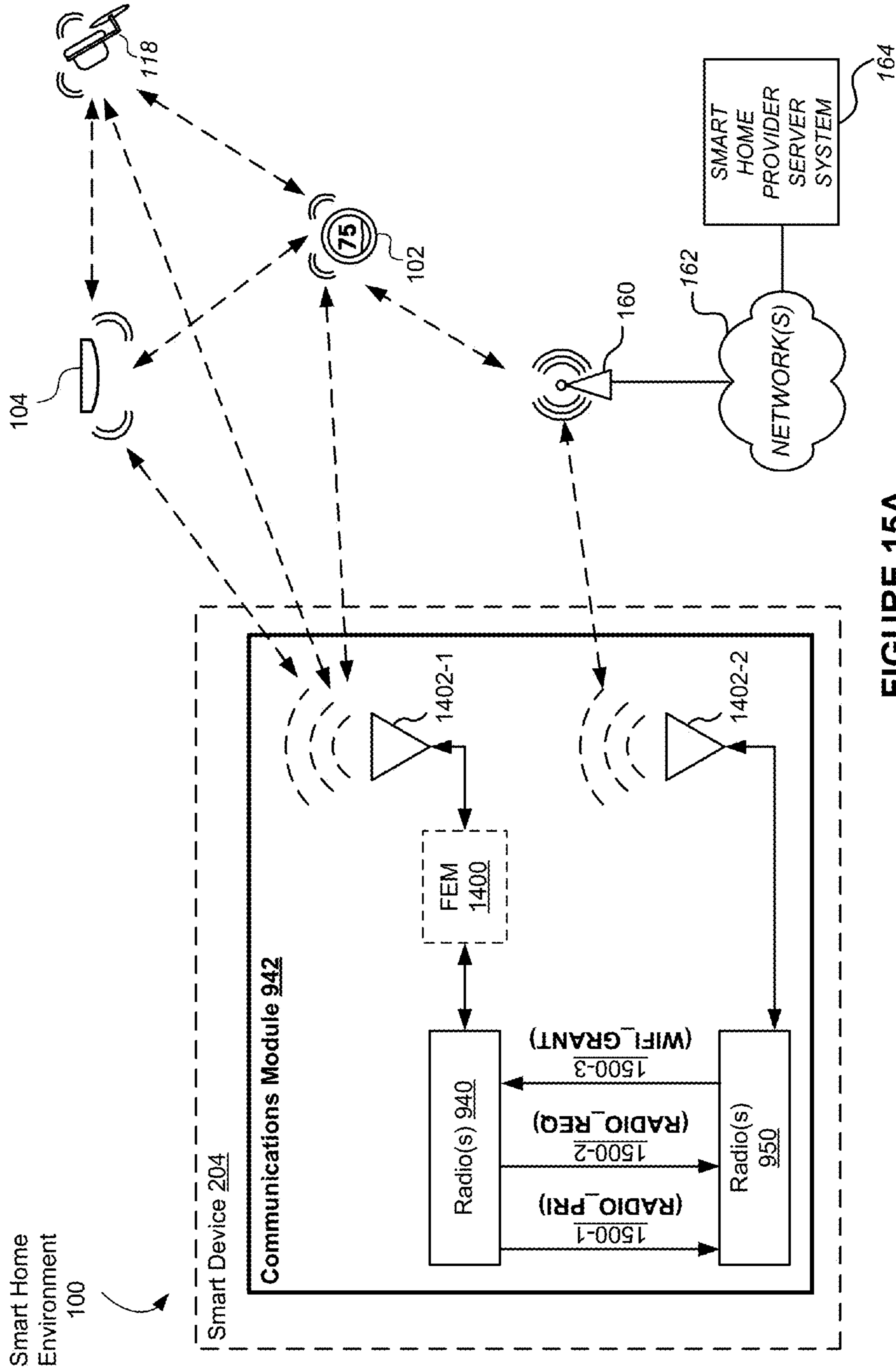

FIGURE 15A

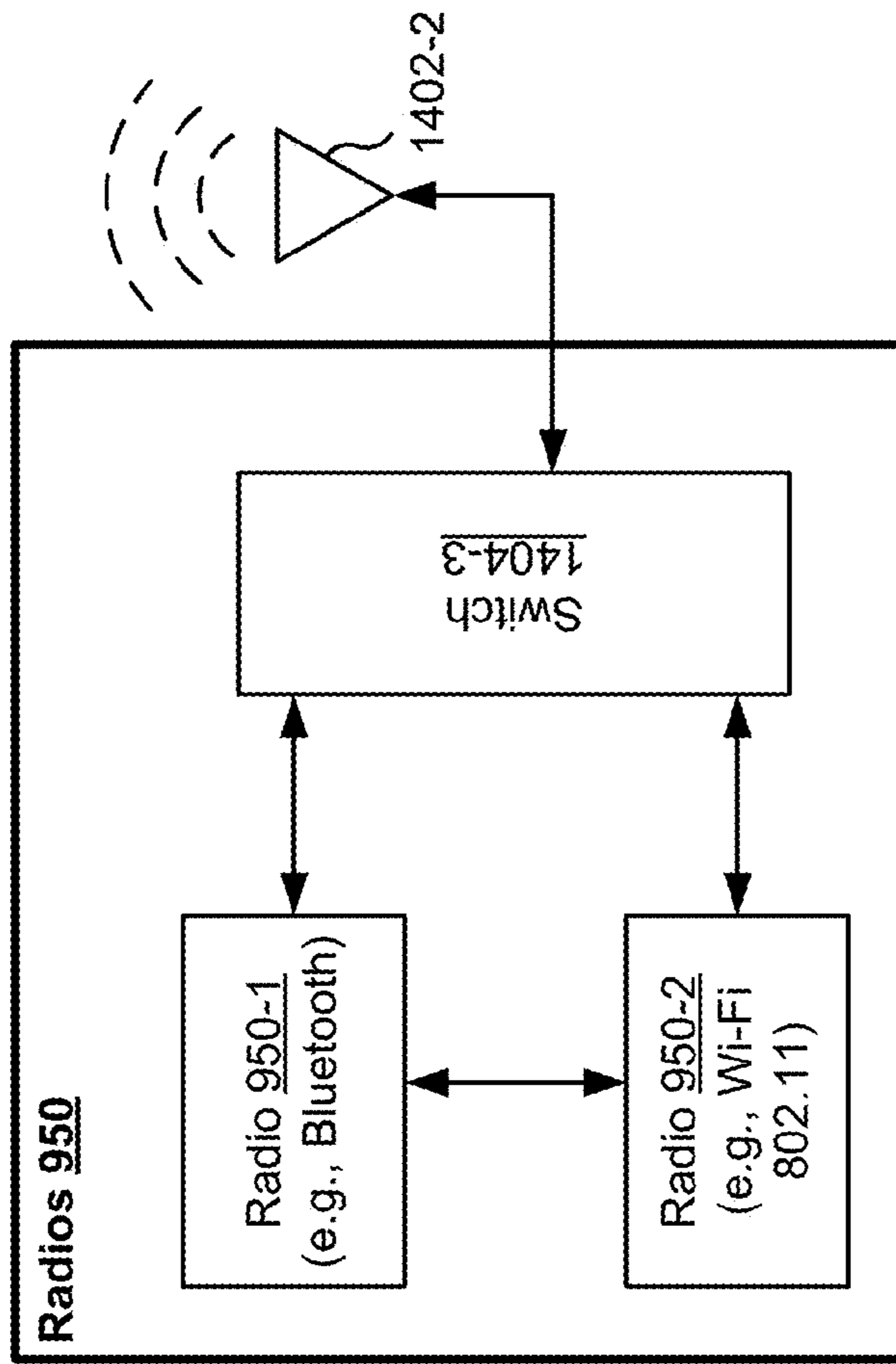

FIGURE 15B



Signal name	Description	Direction (from WiFi)	Assigned to WiFi pin
RADIO_REQ	802.15.4 radio is requesting access to the Wireless medium	Input	L6
RADIO_PRI	802.15.4 request priority.	Input	L7
WIFI_GRANT	WiFi radio is granting 802.15.4 radio access to the wireless medium	Output	L8

FIGURE 15C

Normal Mode

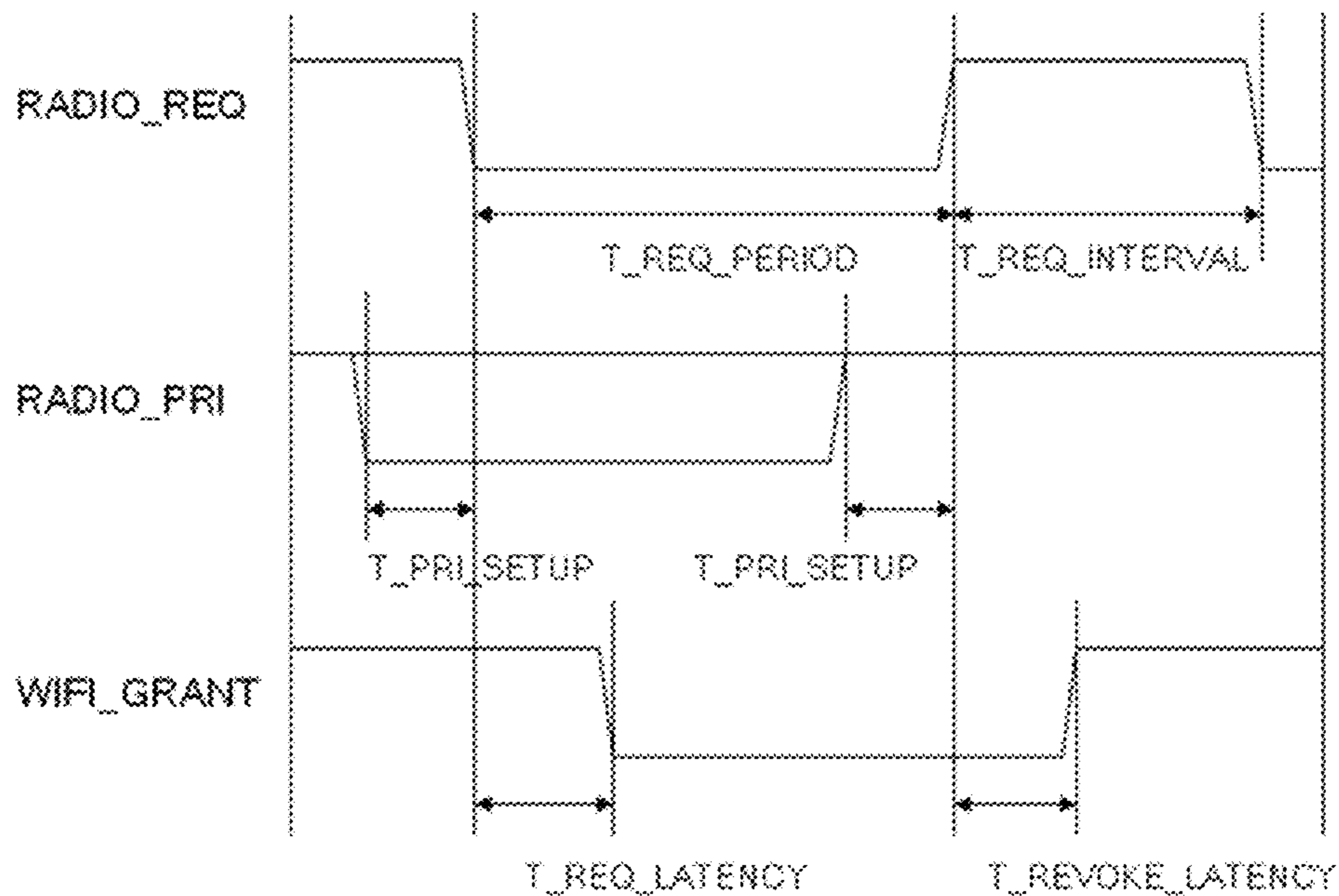

FIGURE 15D-1

Name	Description	min	max
T_REQ_PERIOD	Length of holding RADIO_REQ asserted.		
T_REQ_INTERVAL	Interval between RADIO_REQ	10ms	N/A
T_PRI_SETUP	Setup time to establish RADIO_PRI before asserting RADIO_REQ.	0	N/A
T_REQ_LATENCY	Latency between RADIO_REQ assert and WIFI_GRANT assert.	30us	
T_REVOKE_LATENCY	Latency between RADIO_REQ de-assert and WIFI_GRANT de-assert.	30us	3.5ms

FIGURE 15D-2

High Priority Wi-Fi (i.e., Grant Revoke)

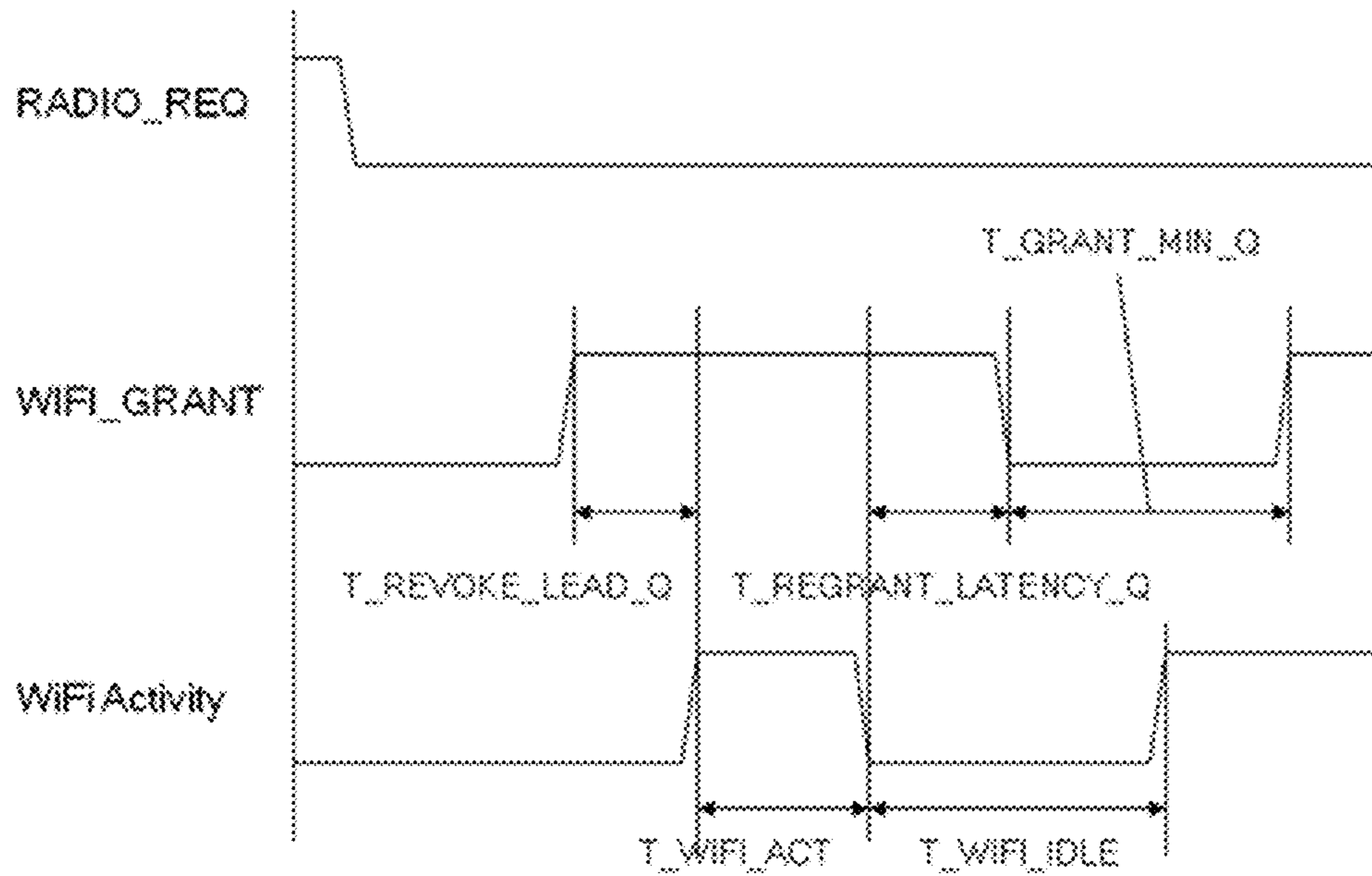

FIGURE 15E-1

Name	Description	min	max
T_REVOKE_LEAD_Q	Lead period between WIFI_GRANT is de-asserted and WiFi transmission.	200ns	N/A
T_REGRANT_LATENCY_Q	Latency between WiFi transmission is done and WIFI_GRANT is re-asserted.	0	N/A
T_GRANT_MIN_Q	Minimum period which WIFI_GRANT can be guaranteed to be asserted.	0	N/A
T_WIFLACT	Period for high-priority WiFi transmission.	400us	N/A
T_WIFLIDLE	Interval between high-priority WiFi transmission request	0	N/A

FIGURE 15E-2



Beacon Protection

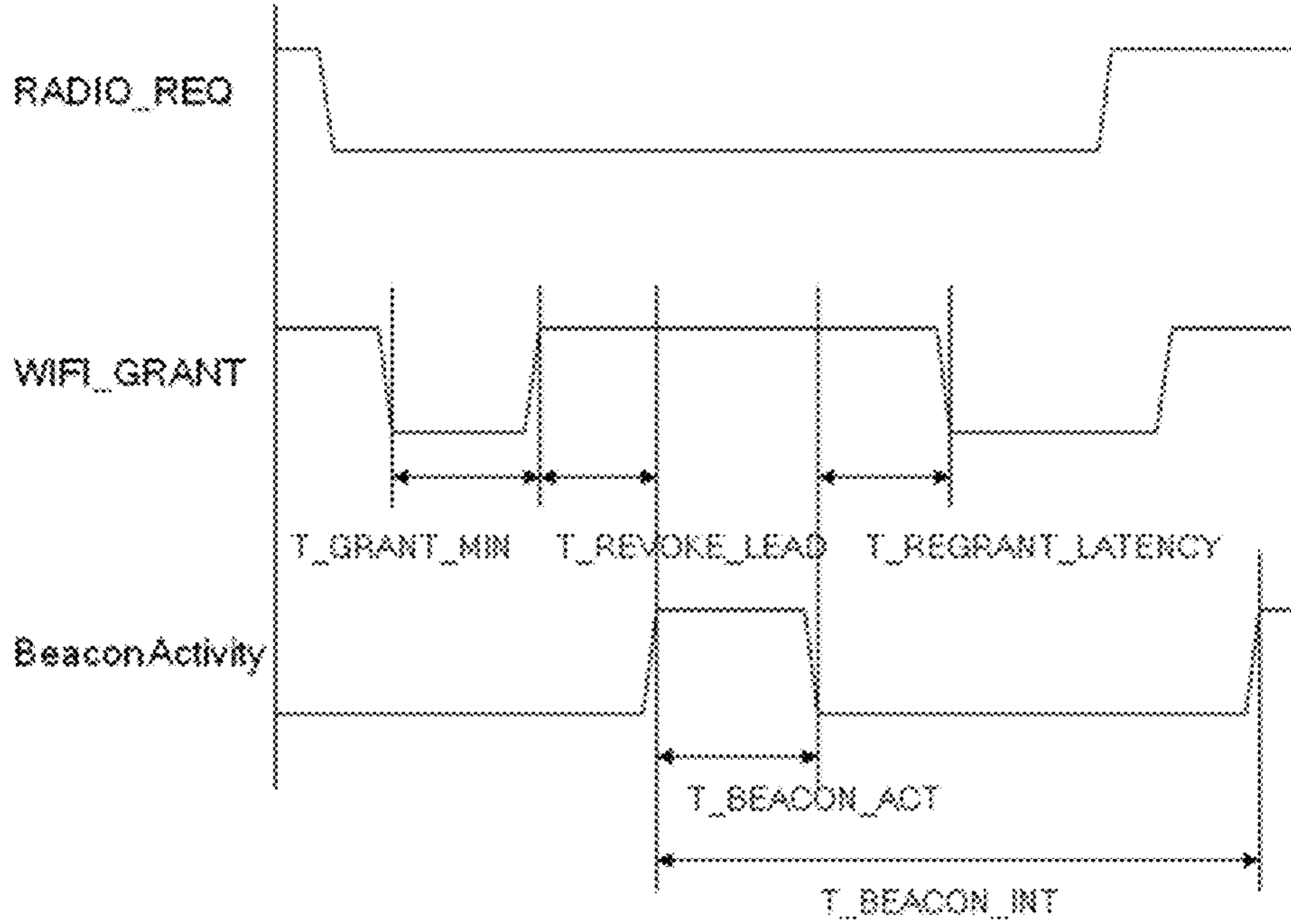
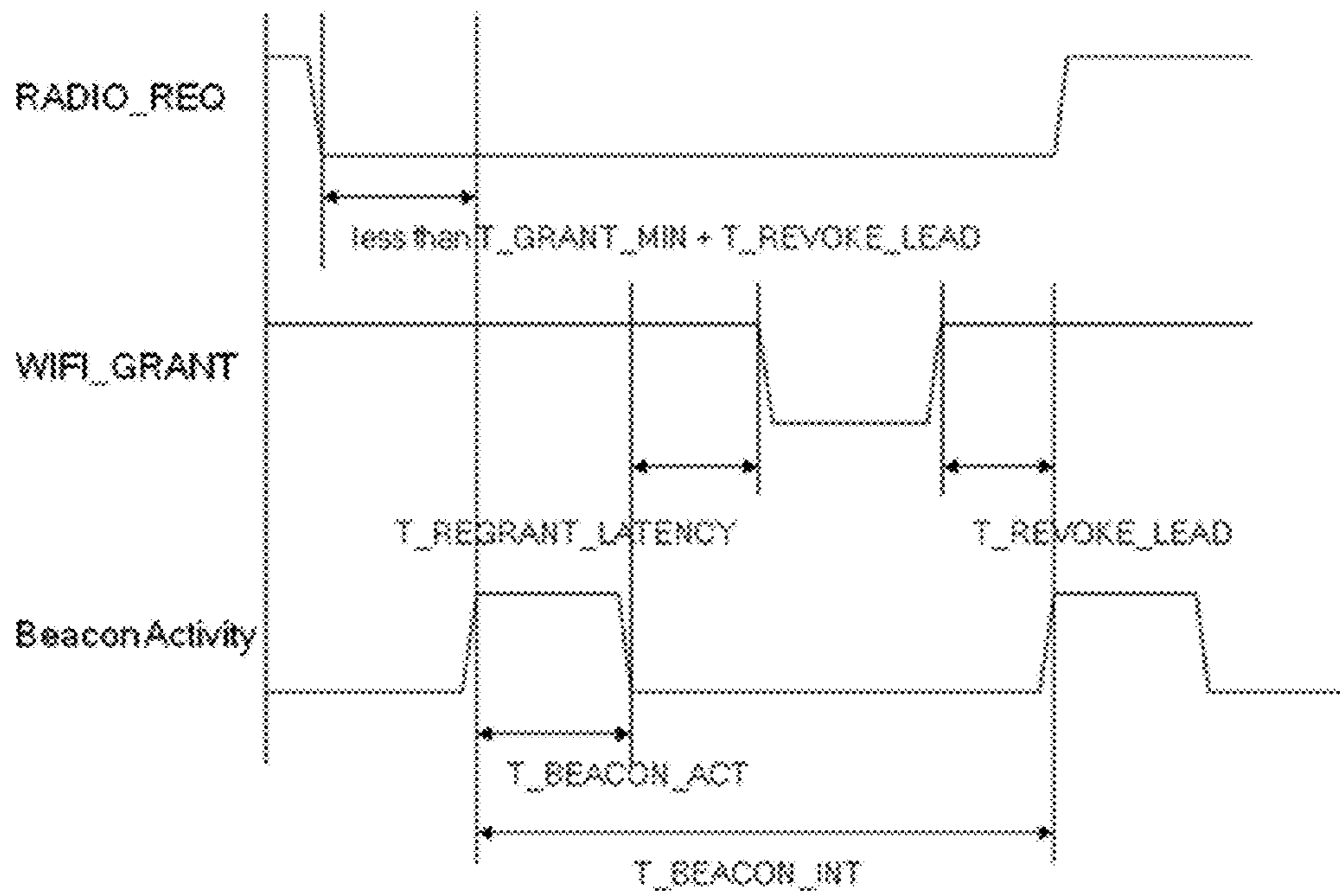

FIGURE 15F-1

Name	Description	min	max
T_GRANT_MIN	Minimum period which WIFI_GRANT can be guaranteed to be asserted before revoked by beacon.		N/A
T_REVOKE_LEAD	Lead period between WIFI_GRANT is de-asserted and WiFi beacon is scheduled to be received.		N/A
T_REGRANT_LATENCY	Latency between WiFi beacon is received (or missed) and WIFI_GRANT is re-asserted.	0	N/A
T_BEACON_ACT	Period between WiFi beacon is received or missed.	N/A	
T_BEACON_INT	WiFi beacon interval		N/A

FIGURE 15F-2

### Beacon Skipping



**FIGURE 15F-3**

Alarming Mode

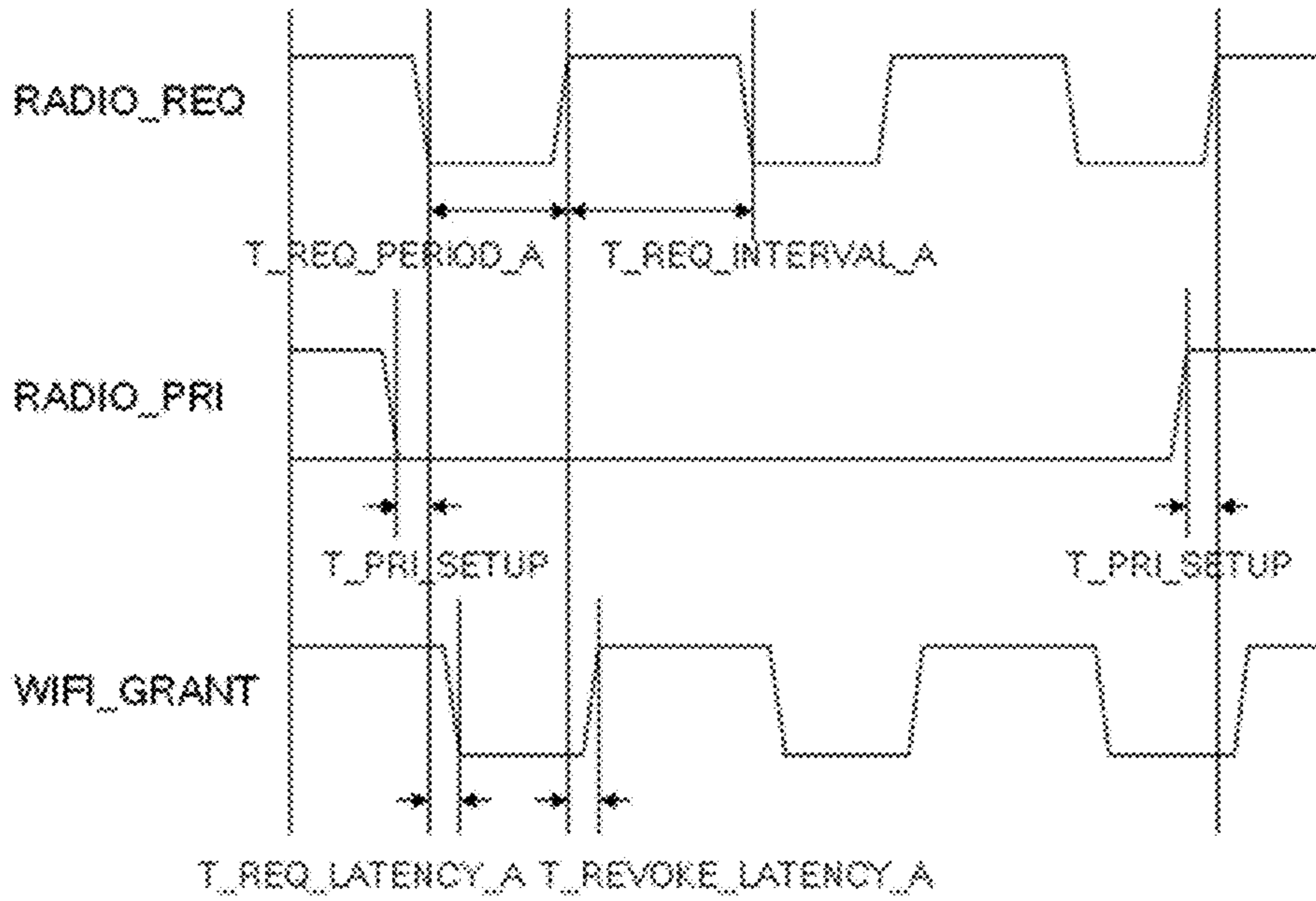

FIGURE 15G-1

Name	Description	min	max
T_REQ_PERIOD_A	Duration to hold RADIO_REQ in alert mode.	900us	N/A
T_REQ_INTEVAL_A	Interval between RADIO_REQ in alert mode.	3100us	N/A
T_REQ_LATENCY_A	Latency between RADIO_REQ assert and WIFI_GRANT assert in alert mode.	30us	5ms (*2)
T_REVOKE_LATENCY_A	Latency between RADIO_REQ de-assert and WIFI_GRANT de-assert in alert mode.	30us	5ms (*2)

FIGURE 15G-2



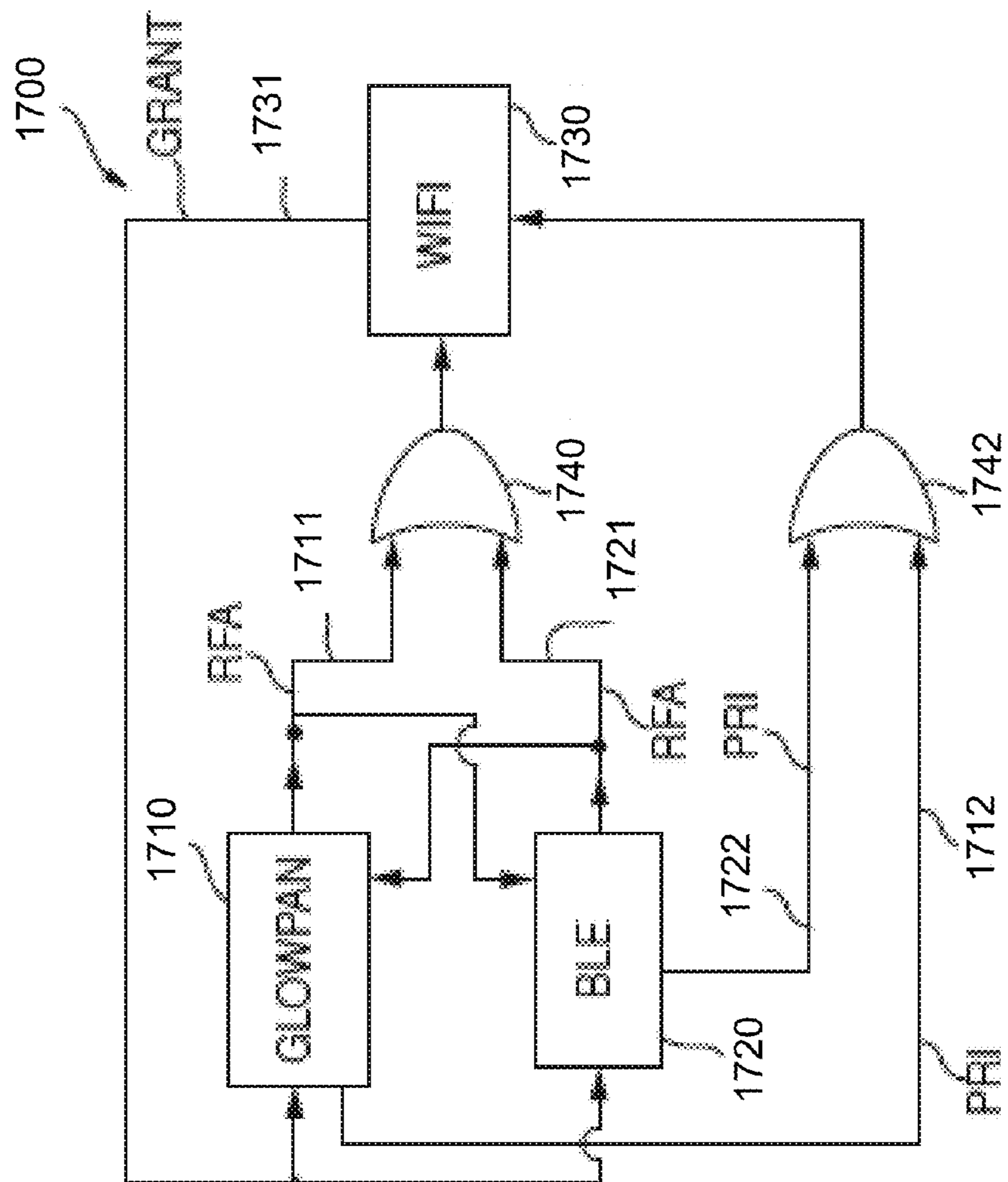

FIGURE 16

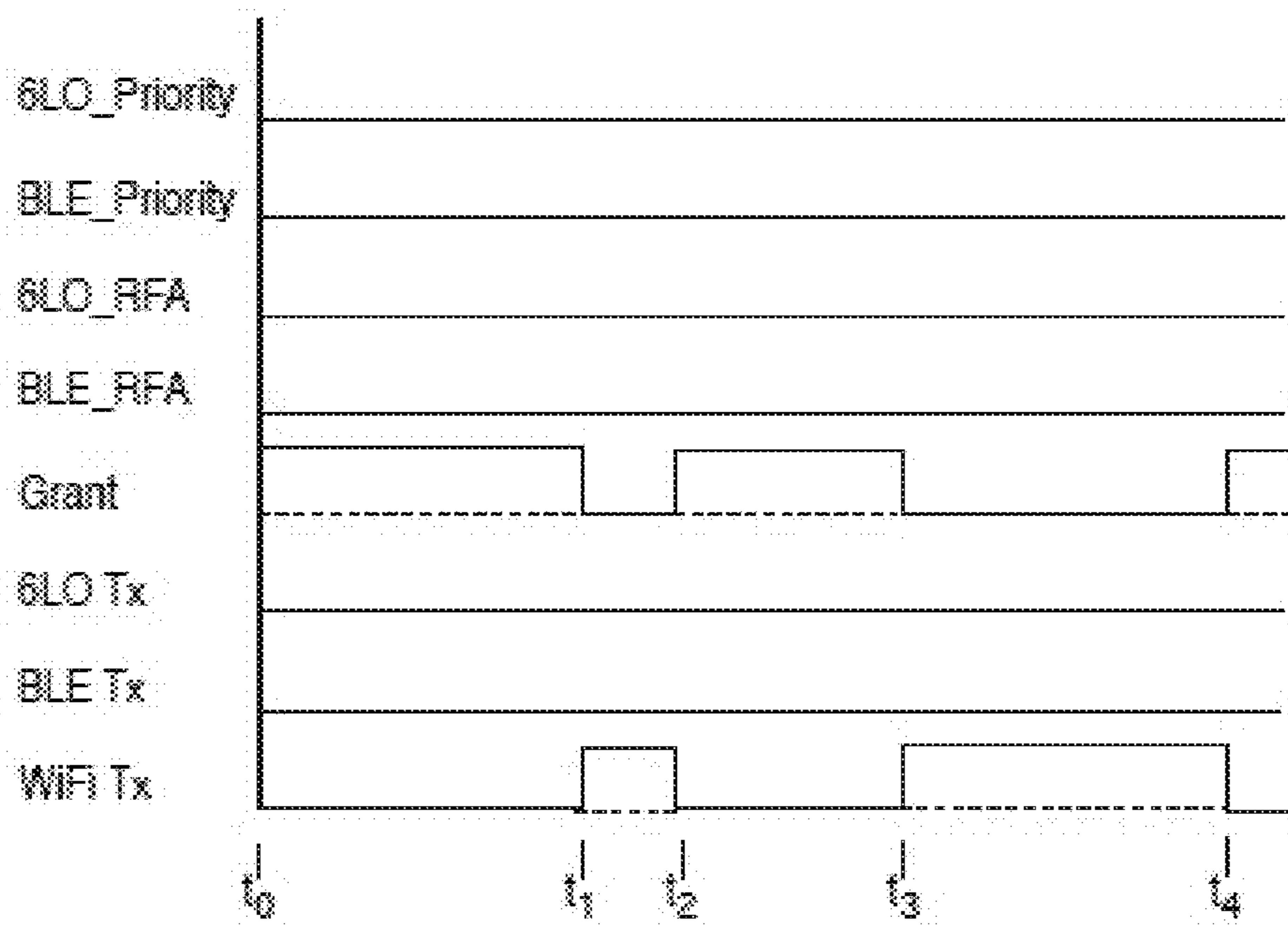

FIGURE 17A

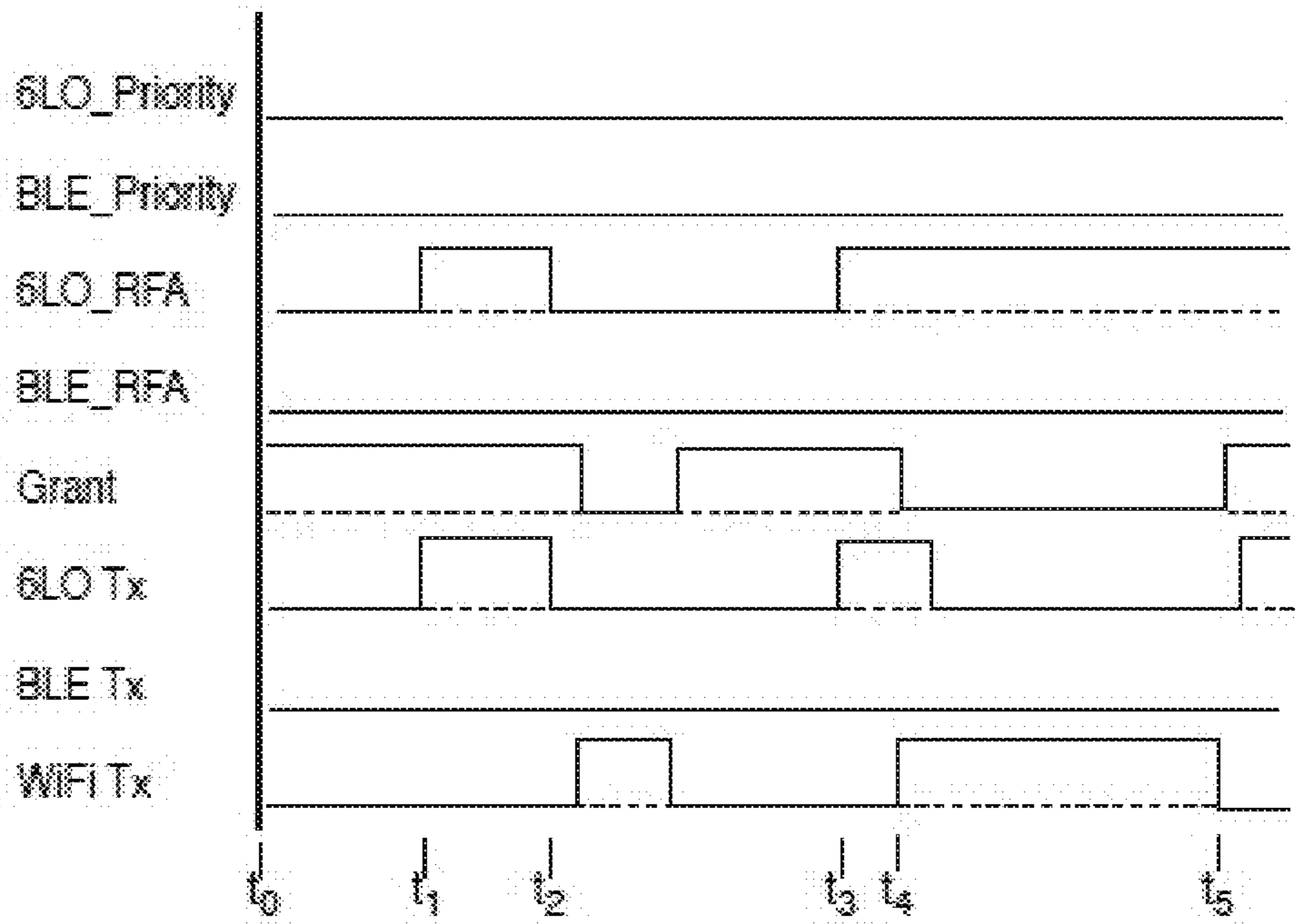

FIGURE 17B



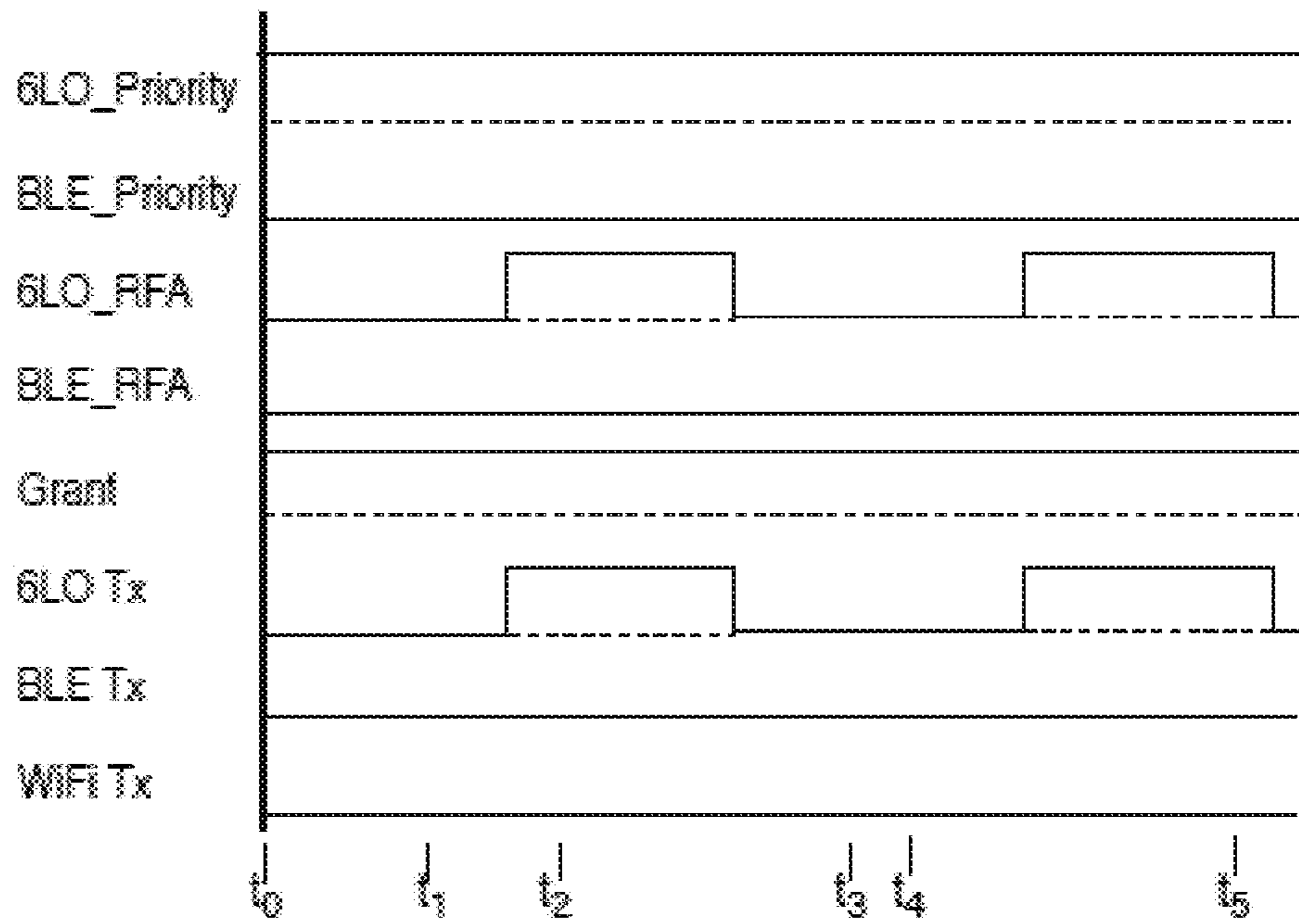
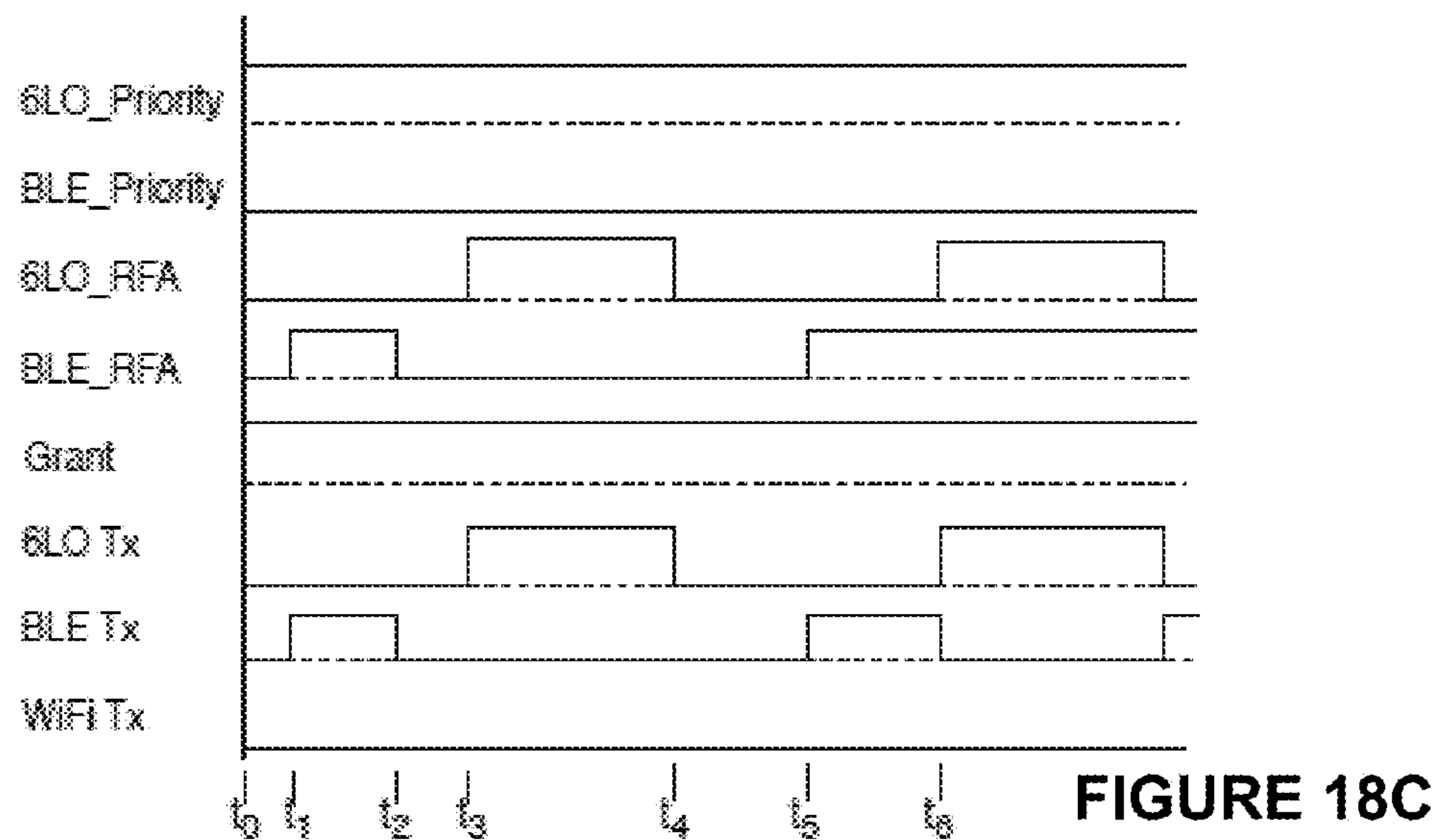
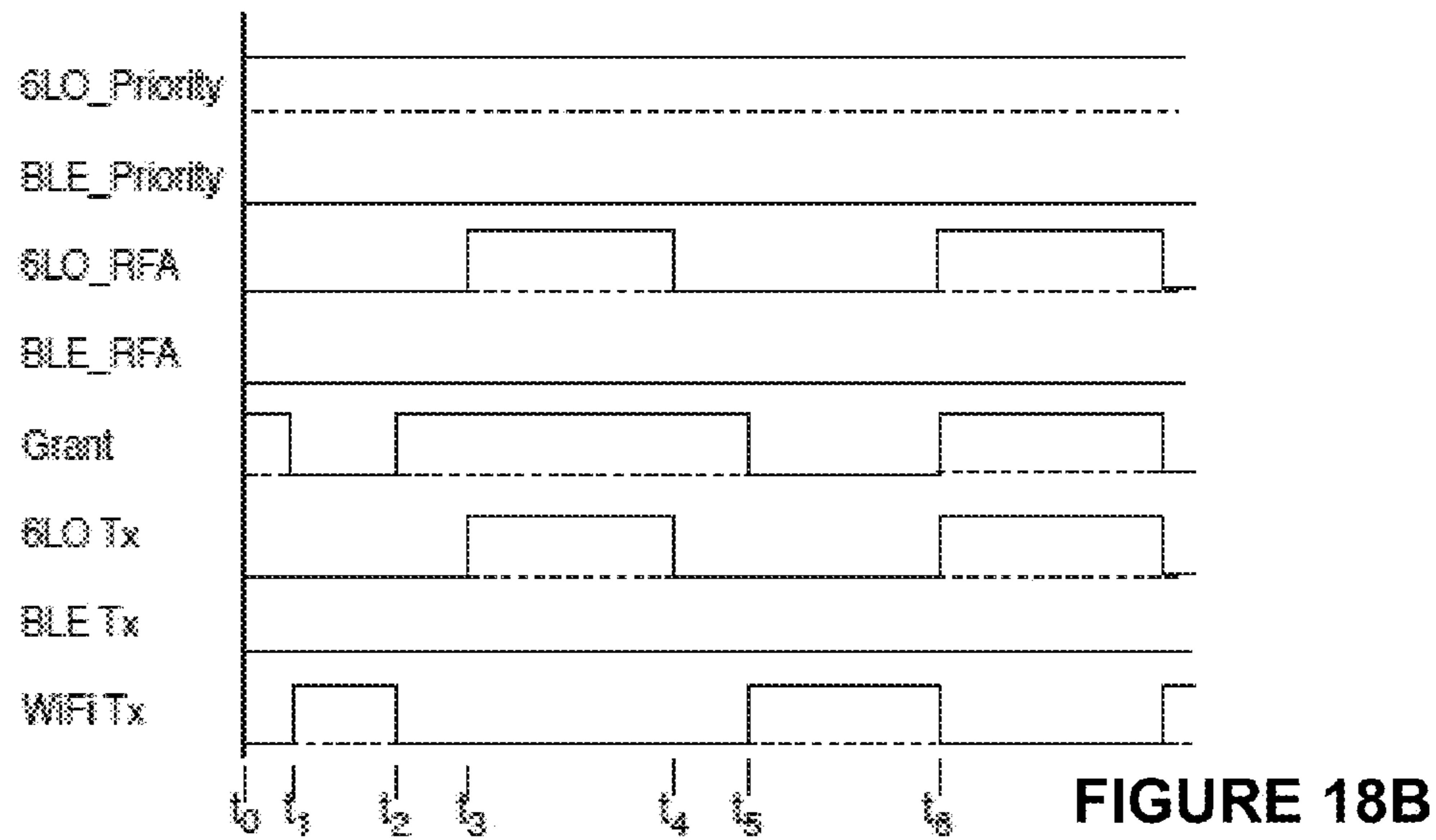

FIGURE 18A



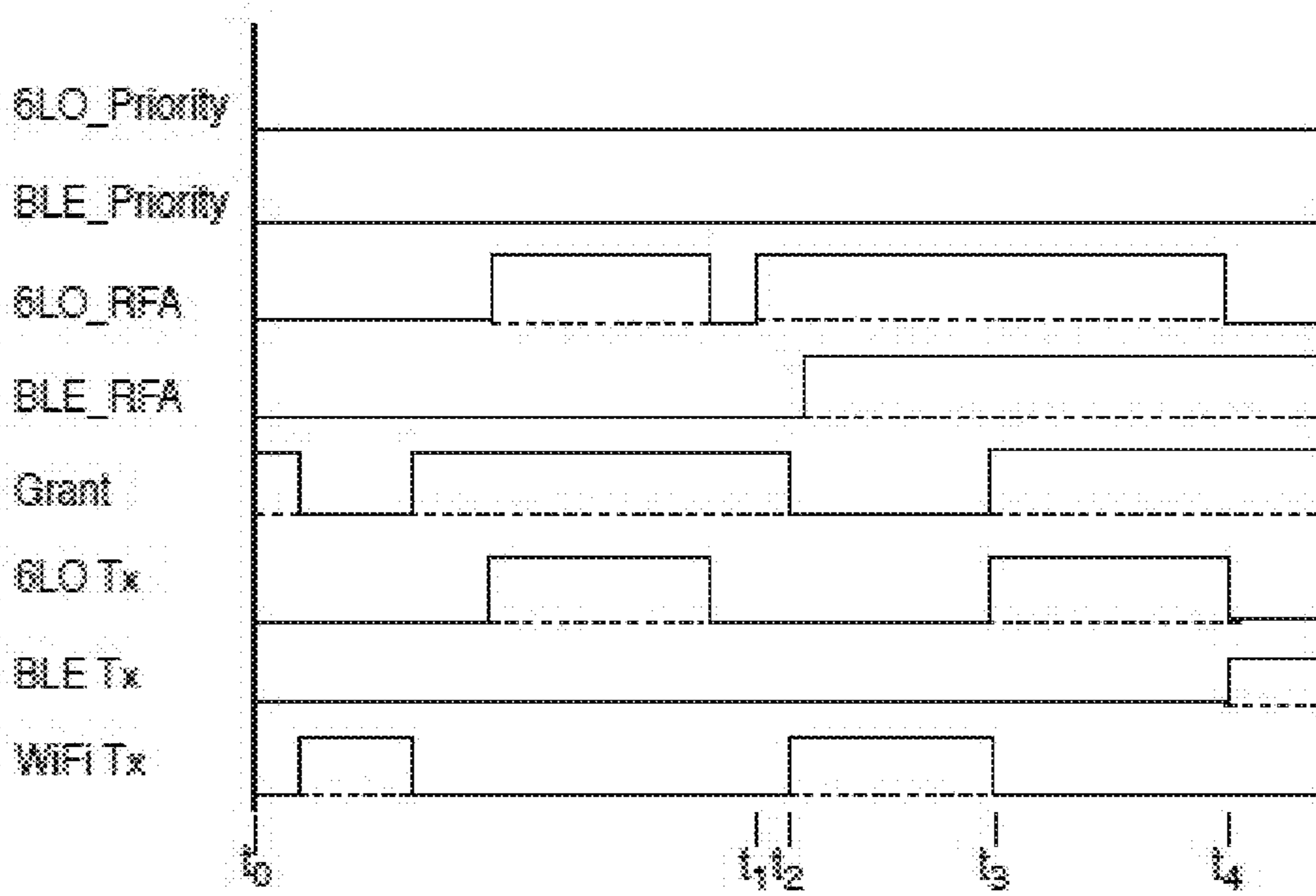

FIGURE 18D

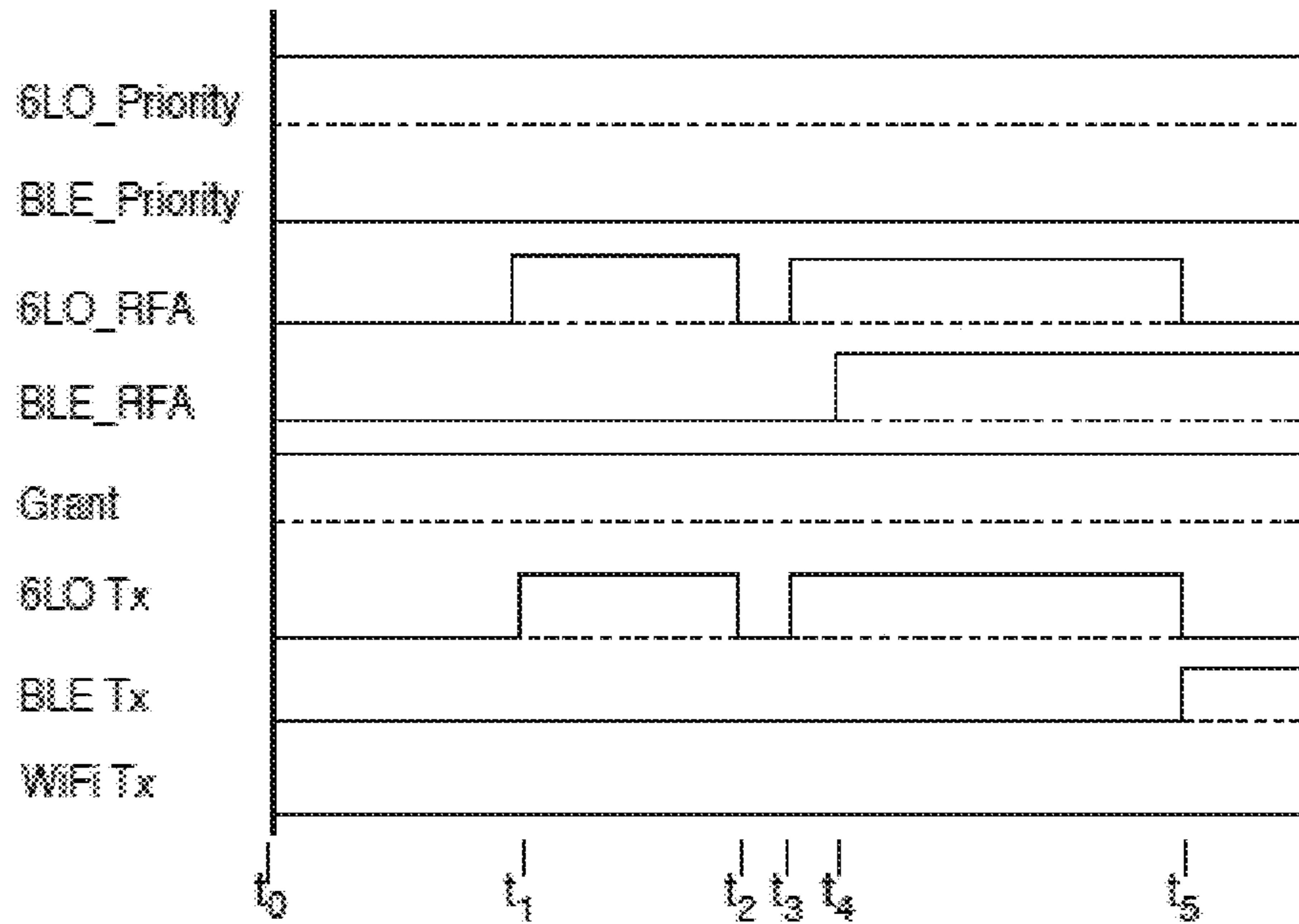

FIGURE 19A

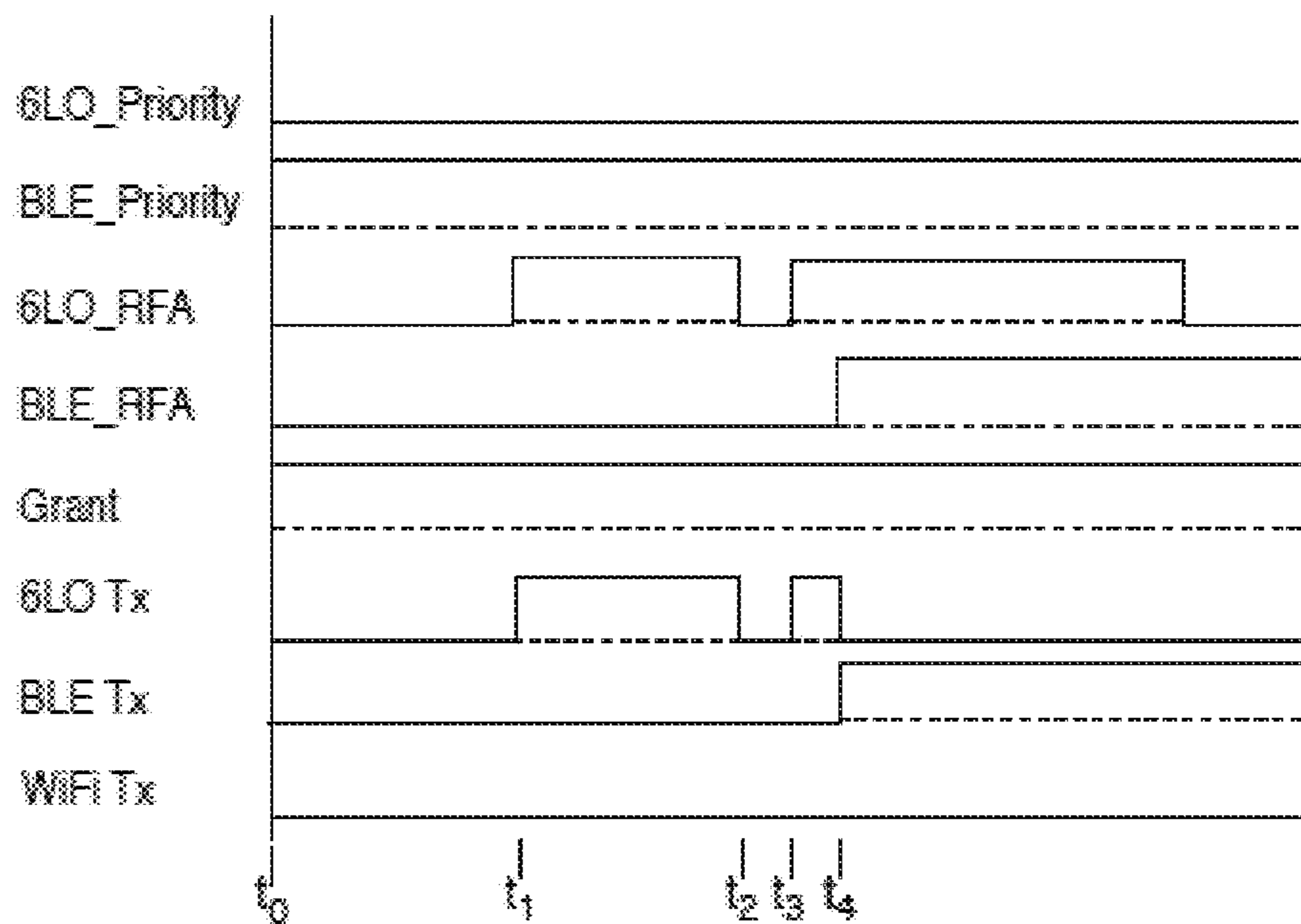

FIGURE 19B



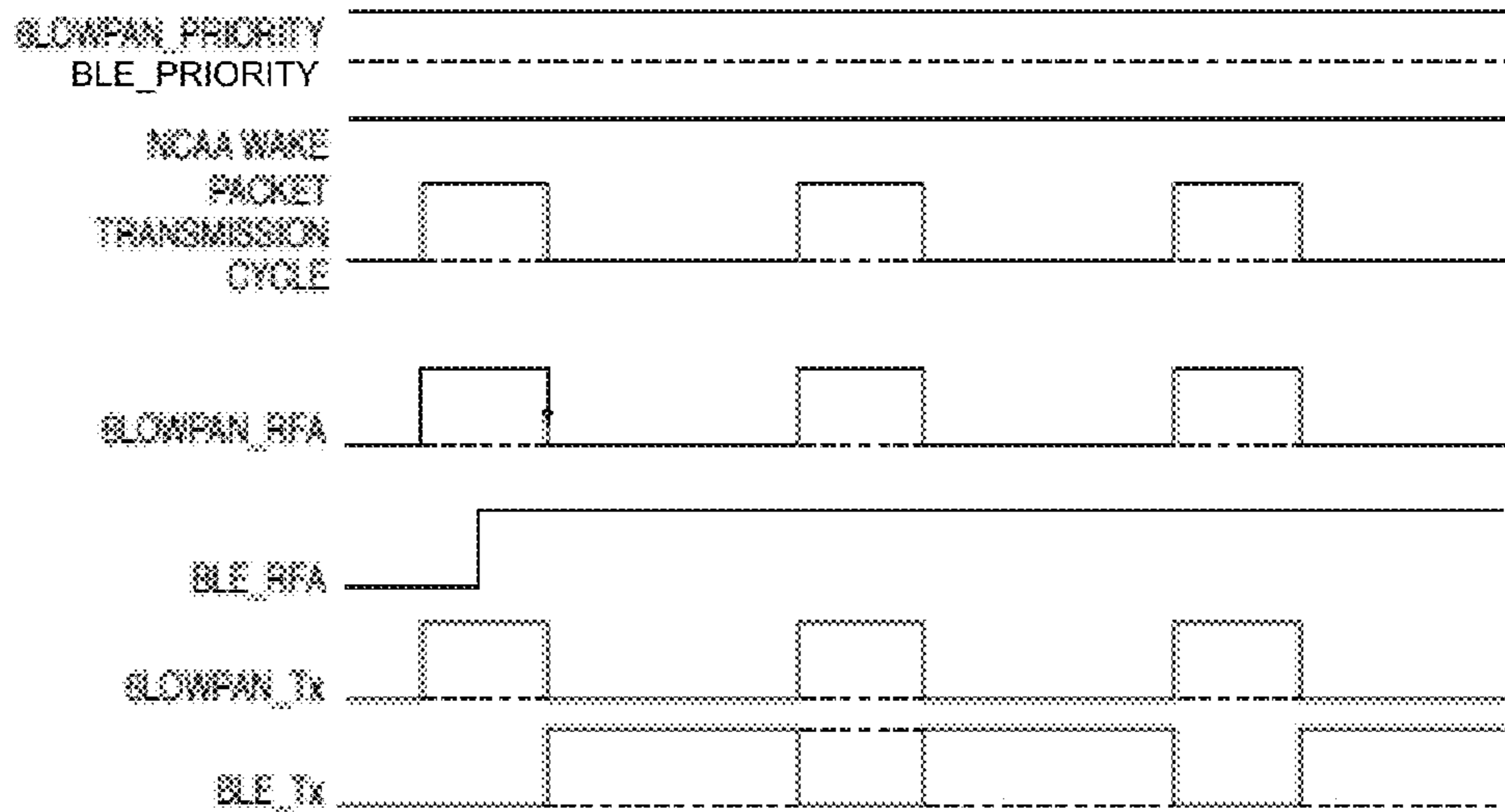

FIGURE 20

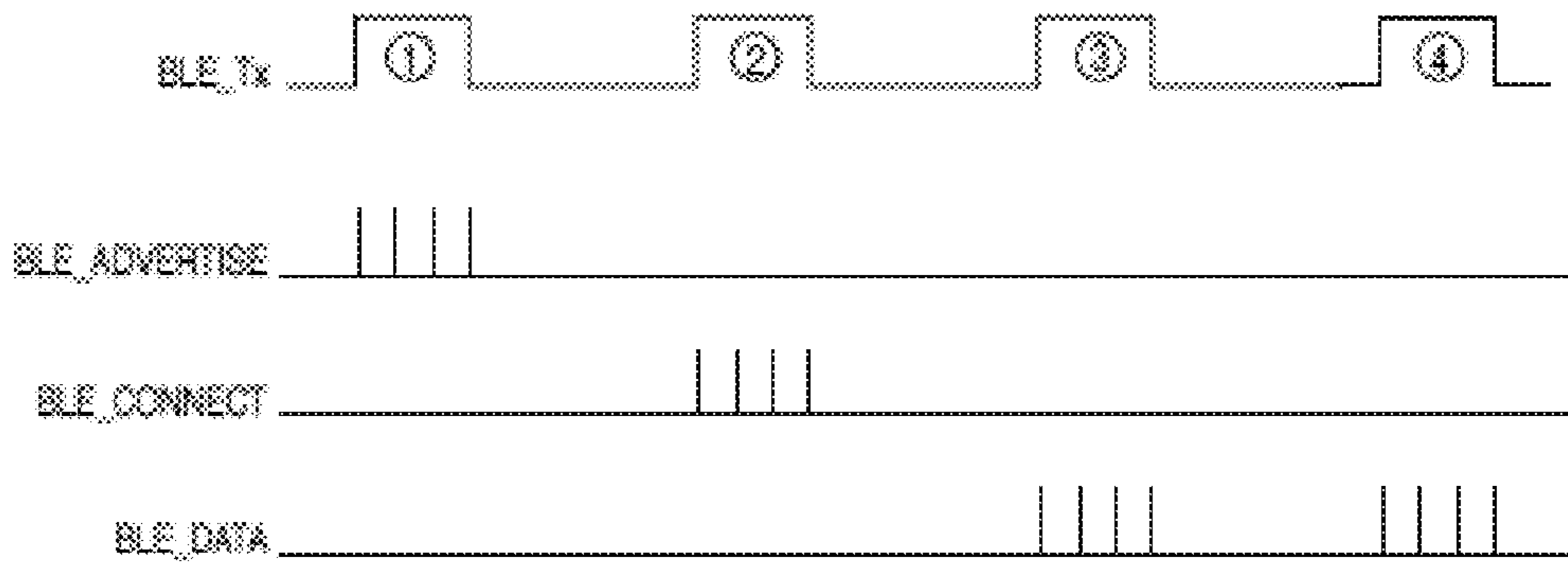

FIGURE 21

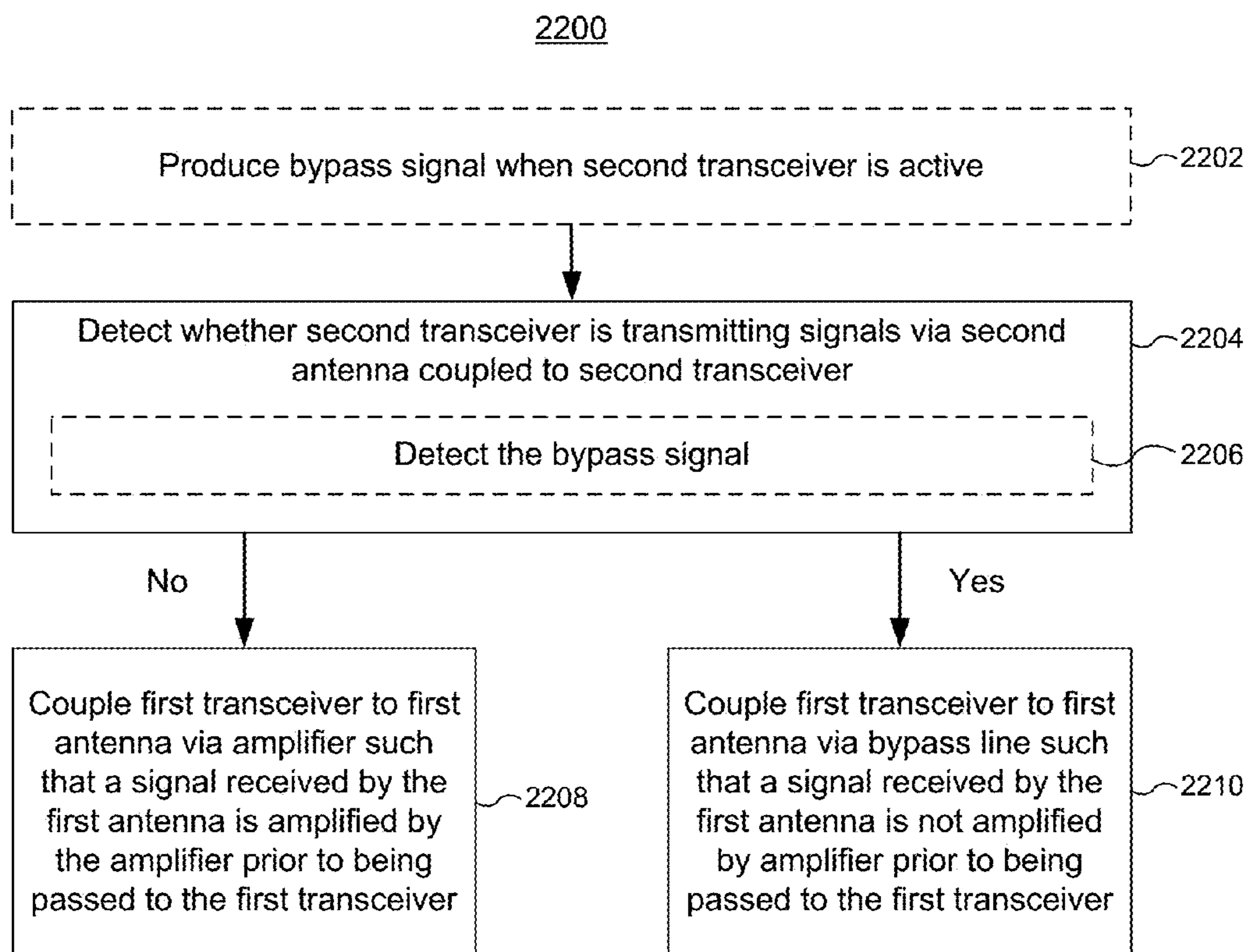

FIGURE 22

2300

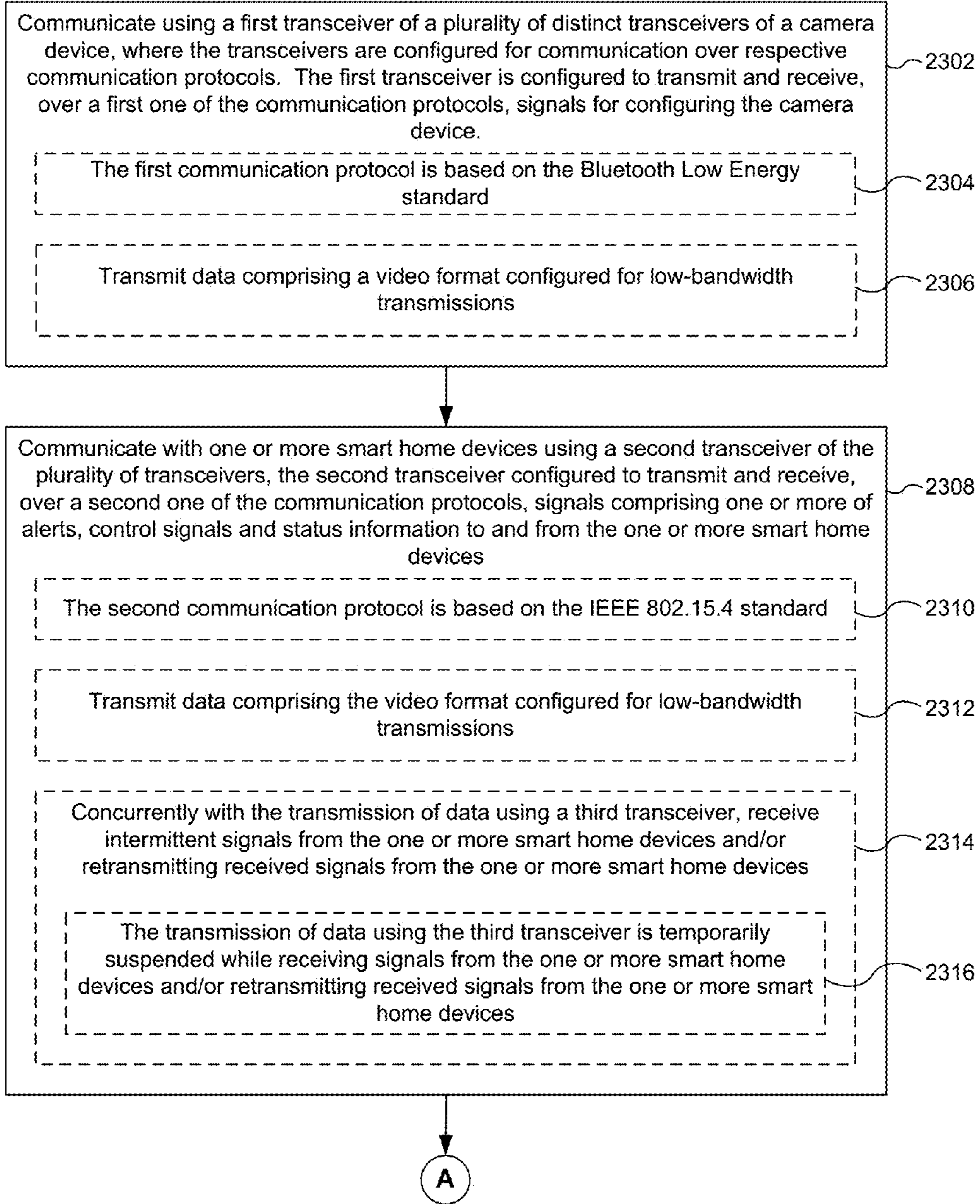

FIGURE 23A

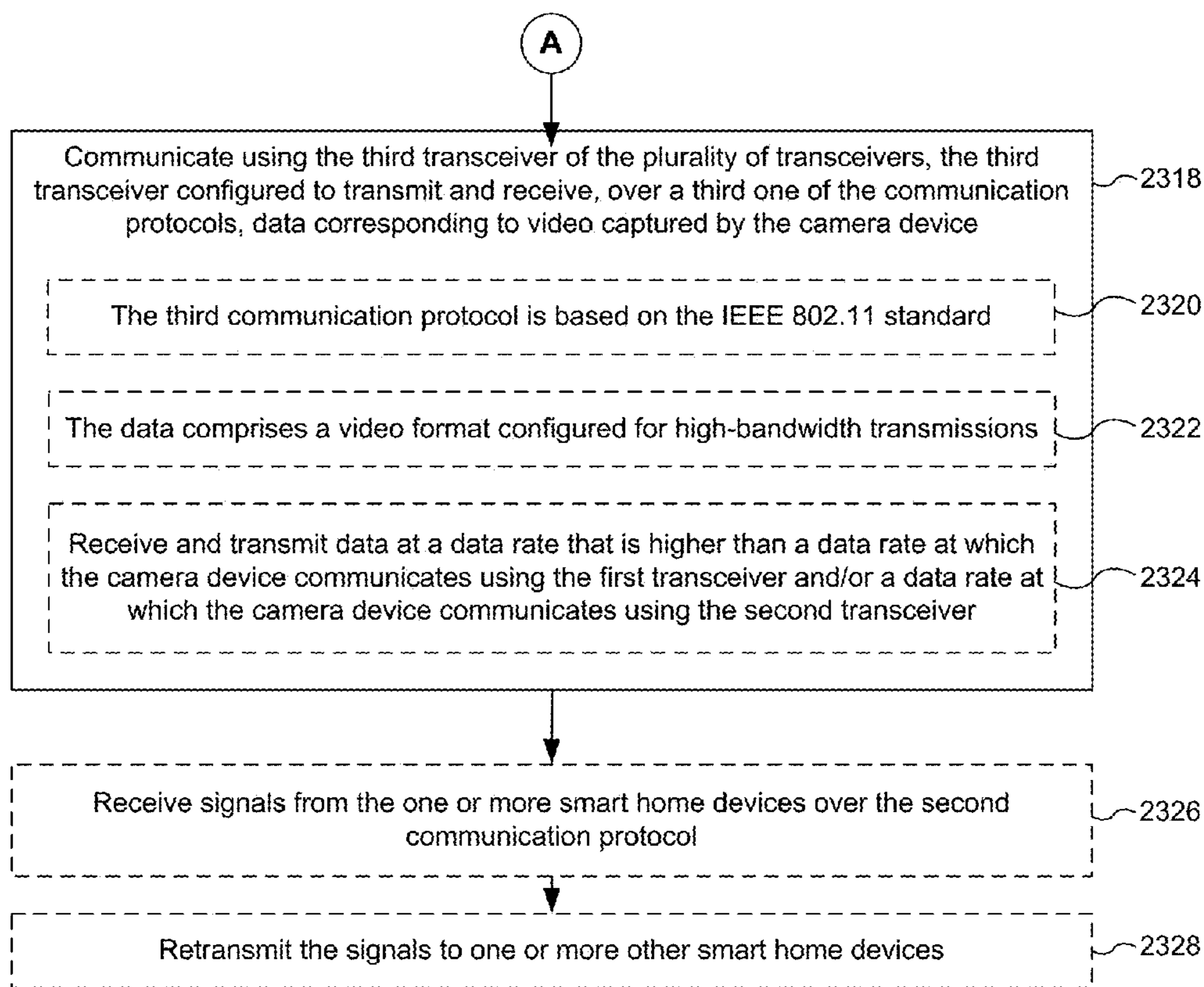

FIGURE 23B



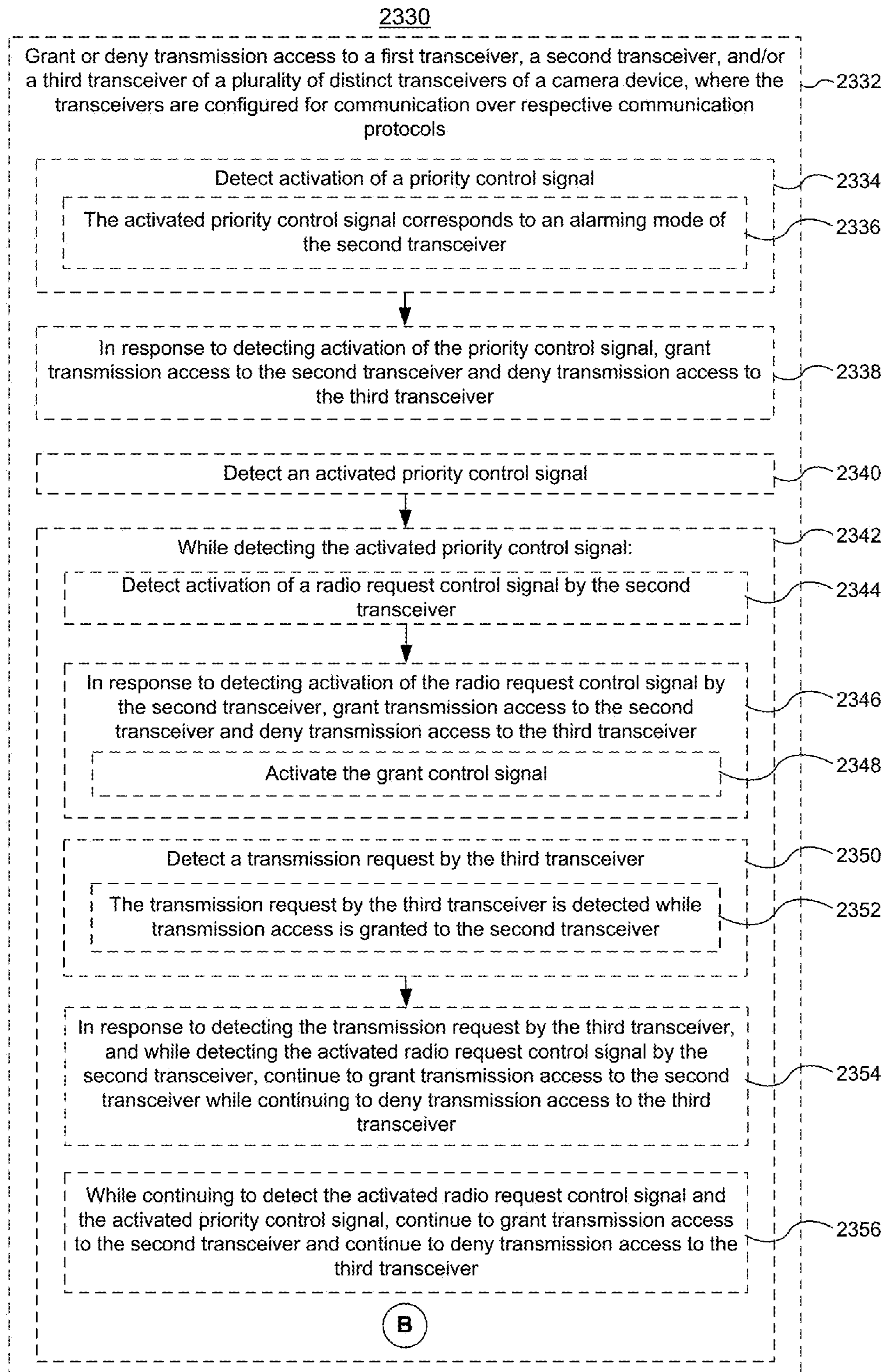

FIGURE 23C

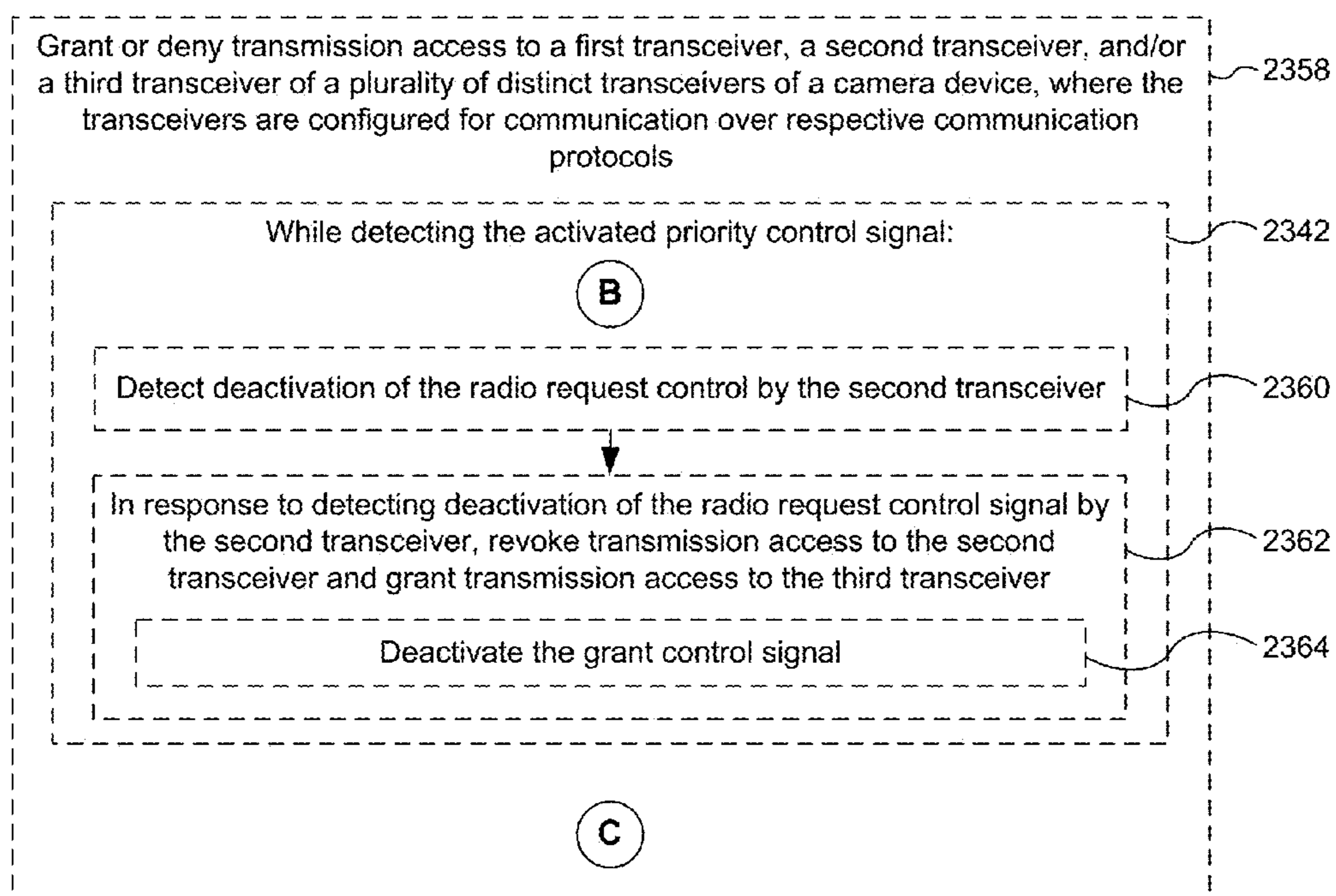

FIGURE 23D

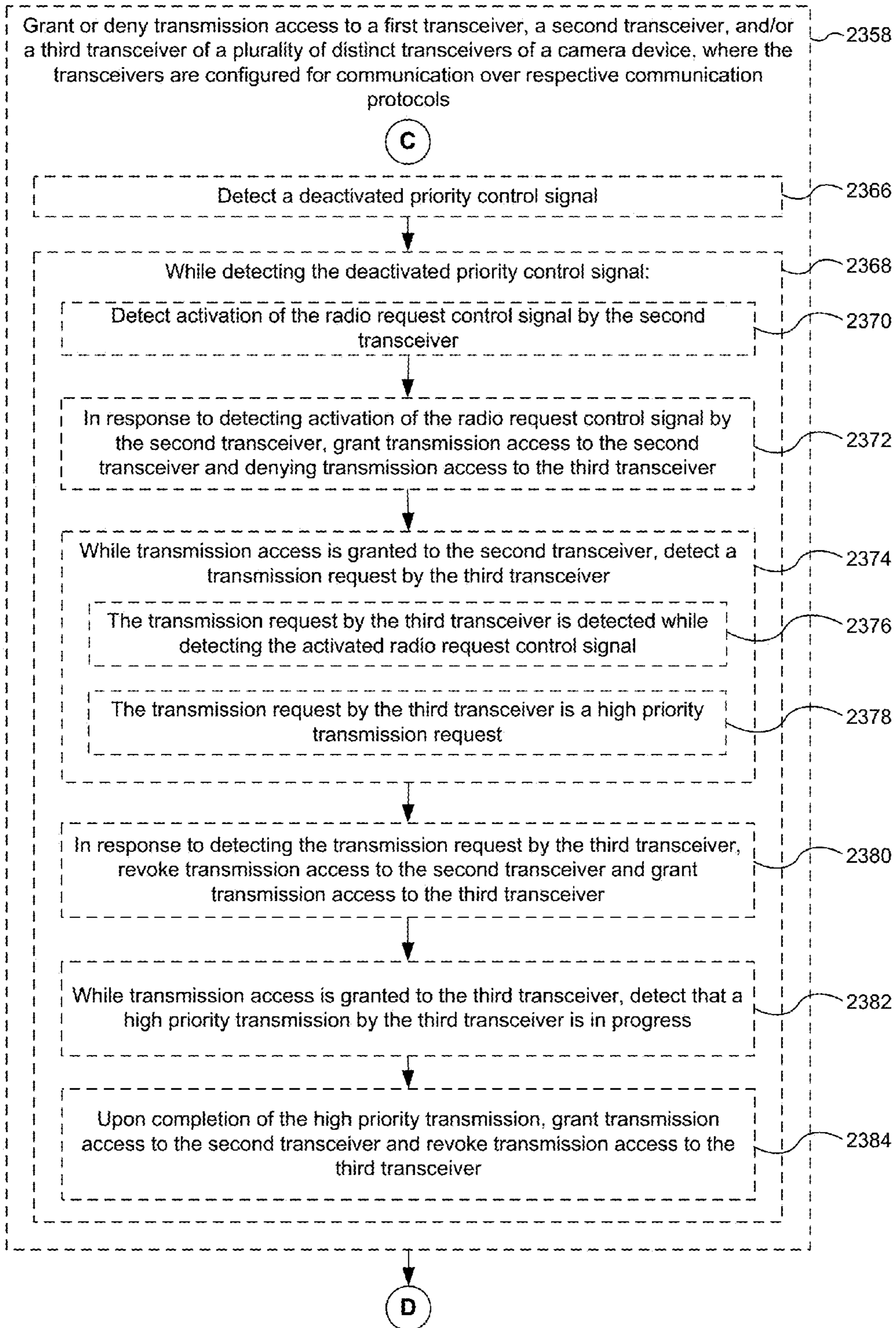
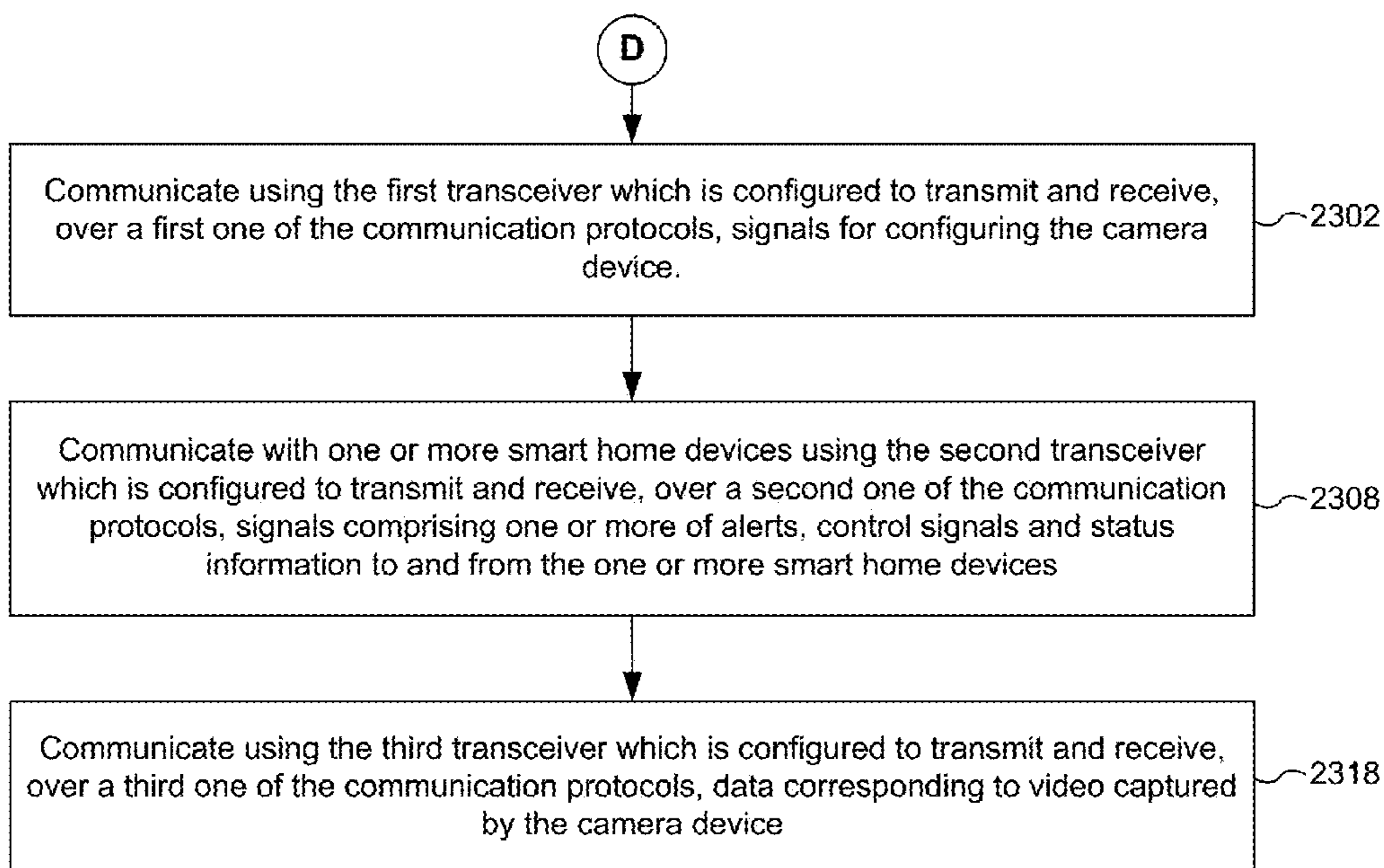

FIGURE 23E



**FIGURE 23F**



1

**SYSTEMS, METHODS, AND DEVICES FOR  
MANAGING COEXISTENCE OF MULTIPLE  
TRANSCEIVER DEVICES BY OPTIMIZING  
COMPONENT LAYOUT**

RELATED APPLICATIONS

This application claims priority to U.S. Provisional Application No. 62/175,393, filed Jun. 14, 2015, entitled "Systems, Methods, and Devices for Managing Coexistence of Multiple Transceiver Devices by Optimizing Component Layout," which is hereby incorporated by reference in its entirety.

This application is related to U.S. patent application Ser. No. 14/616,302, filed Feb. 6, 2015, entitled "Systems and Methods for Processing Coexisting Signals for Rapid Response to User Input," U.S. patent application Ser. No. 13/656,189, filed Oct. 19, 2012, entitled "User-friendly, network connected learning thermostat and related systems and methods," and U.S. patent application Ser. No. 13/835,439, filed Mar. 15, 2013, entitled "Detector unit and sensing chamber therefor," which are hereby incorporated by reference in their entirety.

TECHNICAL FIELD

This relates generally to computer technology, including but not limited to methods and systems for managing coexistence of multiple transceiver devices.

BACKGROUND

Devices in a smart home environment include a host of circuit components and interfaces for enabling communications with other systems, devices, and/or servers. For example, some smart devices include multiple radios as components of a single integrated circuit collocated within a compact area for receiving and transmitting signals to other devices and across networks. As a consequence of the close physical spacing of components within smart devices, combined with close proximity to nearby conductive materials and the fact that devices often share the same or close frequency bands in operation, device components typically exhibit poor isolation from transmissions of one another. In addition to poor communications performance, sensitive device components are also at risk of damage when their input power thresholds are exceeded due to poor isolation.

SUMMARY

Accordingly, there is a need for methods, apparatuses, and systems for managing coexistence of multiple transceivers in a device. By utilizing various component layout strategies within a device, using bypass circuitry, and/or using various control signals for prioritizing transmission access, the impact and harmful effects arising from poorly isolated transceivers in a device are reduced.

In accordance with some implementations, a camera assembly includes an enclosed housing having a rear surface, a front surface, and a periphery. Furthermore, the camera assembly includes a lens module located within the housing and configured to receive light via the front surface, and communication circuitry located within the housing and configured to wireless communicate over a plurality of different communication protocols. The camera assembly further includes a first antenna arranged at a first location on an inner surface of the periphery, the first antenna configured for communication over a first one of the communication protocols,

2

and a second antenna arranged at a second location on the inner surface of the periphery, the second location being different than the first location, the second antenna configured for communication over a second one of the communication protocols.

Another aspect includes a communications apparatus including a first and second transceiver, and a first and second antenna. The communications apparatus further includes a front end module (FEM) coupled between the first transceiver and the first antenna, the front end module including an amplifier for amplifying signals received by the first antenna, and a bypass line. The FEM is configured to couple the first antenna to the first transceiver via the bypass line when the second transceiver is active and transmitting signals using the second antenna such that a signal received via the first antenna is not amplified by the amplifier prior to being passed to the first transceiver. Furthermore, the FEM is configured to couple the first antenna to the first transceiver via the amplifier when the second transceiver is not transmitting signals using the second antenna such that a signal received via the first antenna is amplified by the amplifier prior to being passed to the first transceiver.

In accordance with some implementations, a method for communicating via a plurality of transceivers includes coupling a first transceiver of a plurality of transceivers of an electronic device to a first antenna via an amplifier such that a signal received by the first antenna is amplified by the amplifier prior to being passed to the first transceiver, in accordance with detecting that a second transceiver of the plurality of transceivers is not transmitting signals via a second antenna coupled to the second transceiver. The method further includes coupling the first transceiver to the first antenna via a bypass line such that a signal received by the first antenna is not amplified by the amplifier prior to being passed to the first transceiver, in accordance with detecting that the second transceiver is transmitting signals via the second antenna.

In accordance with some implementations, a communications apparatus including a first and second transceiver, and a first and second antenna. The communications apparatus further includes a coupling means. The coupling means is configured to couple the first antenna to the first transceiver via the bypass line when the second transceiver is active and transmitting signals using the second antenna such that a signal received via the first antenna is not amplified by the amplifier prior to being passed to the first transceiver. Furthermore, the coupling means is configured to couple the first antenna to the first transceiver via the amplifier when the second transceiver is not transmitting signals using the second antenna such that a signal received via the first antenna is amplified by the amplifier prior to being passed to the first transceiver.

Another aspect includes a method for communicating via a plurality of transceivers, the method performed at a camera device comprising a plurality of distinct transceivers configured for communication over respective communication protocols, one or more processors, and memory storing instructions for execution by the one or more processors. The method includes communicating using a first transceiver of the plurality of transceivers, the first transceiver configured to transmit and receive, over a first one of the communication protocols, signals for configuring the camera device. Furthermore, the method includes communicating with one or more smart home devices using a second transceiver of the plurality of transceivers, the second transceiver configured to transmit and receive, over a second one of the communication protocols, signals comprising one or more of alerts, control signals



and status information to and from the one or more smart home devices. Furthermore, the method includes communicating using a third transceiver of the plurality of transceivers, the third transceiver configured to transmit and receive, over a third one of the communication protocols, data corresponding to video captured by the camera device.

In accordance with some implementations, a camera device includes a first and second antenna, and a first, second, and third transceiver. The first transceiver is configured to transmit and receive, over a first one of a plurality of distinct communication protocols, signals for configuring the camera device. Furthermore, the second transceiver is configured to transmit and receive, over a second one of the plurality of distinct communication protocols, signals comprising one or more of alerts, control signals and status information to and from the one or more smart home devices. Moreover, the third transceiver is configured to transmit and receive, over a third one of the plurality of distinct communication protocols, data corresponding to video captured by the camera device, wherein the second transceiver is coupled to the first antenna, and the first and third transceivers are coupled to the second antenna.

#### BRIEF DESCRIPTION OF THE DRAWINGS

For a better understanding of the various described implementations, reference should be made to the Description of Implementations below, in conjunction with the following drawings in which like reference numerals refer to corresponding parts throughout the figures.

FIG. 1 is an example smart home environment, in accordance with some implementations.

FIG. 2 is a block diagram illustrating an example network architecture that includes a smart home network, in accordance with some implementations.

FIG. 3 illustrates a network-level view of an extensible devices and services platform with which the smart home environment of FIG. 1 is integrated, in accordance with some implementations.

FIG. 4 illustrates an abstracted functional view of the extensible devices and services platform of FIG. 3, with reference to a processing engine as well as devices of the smart home environment, in accordance with some implementations.

FIG. 5 is a representative operating environment in which a hub device server system interacts with client devices and hub devices communicatively coupled to local smart devices, in accordance with some implementations.

FIG. 6 is a block diagram illustrating a representative hub device, in accordance with some implementations.

FIG. 7 is a block diagram illustrating a representative hub server system, in accordance with some implementations.

FIG. 8 is a block diagram illustrating a representative client device associated with a user account, in accordance with some implementations.

FIG. 9 is a block diagram illustrating a representative smart device, in accordance with some implementations.

FIG. 10 is a block diagram illustrating a representative smart home provider server system, in accordance with some implementations.

FIGS. 11A-11M illustrate various assembly views of a camera device 118, in accordance with some implementations.

FIGS. 12A-12C illustrate various component views of a thermostat, in accordance with some implementations.

FIGS. 13A-13D illustrate various component views of a hazard detector, in accordance with some implementations.

FIG. 14 illustrates a block diagram of a communications module of a smart device utilizing a bypass coexistence technique, in accordance with some implementations.

FIGS. 15A-15G illustrate a coexistence scheme for a smart device having multiple radios in smart home environment, in accordance with some implementations.

FIG. 16 shows an illustrative co-existence circuit for managing operations of three communications circuits, in accordance with some implementations.

FIGS. 17A-17B show priority cases for Wi-Fi circuitry, in accordance with some implementations.

FIGS. 18A-D shows different illustrative 6LoWPAN priority use cases, in accordance with some implementations.

FIGS. 19A-19B show illustrative timing diagrams where Wi-Fi circuitry is OFF, in accordance with some implementations.

FIG. 20 shows an illustrative timing diagram showing how the BLE circuitry attempts to communicate with a personal device during the idle portion of a wake packet being transmitted by 6LoWPAN circuitry during a NCCA period, in accordance with some implementations.

FIG. 21 shows illustrative timing diagrams of exemplary BLE advertise, connect, and data transfer activity during BLE transmissions, in accordance with some implementations.

FIG. 22 is a flow diagram illustrating a method of coexistence using bypass circuitry, in accordance with some implementations.

FIGS. 23A-23F are flow diagrams illustrating methods of using control signals in a coexistence scheme, in accordance with some implementations.

Like reference numerals refer to corresponding parts throughout the several views of the drawings.

#### DESCRIPTION OF IMPLEMENTATIONS

Reference will now be made in detail to implementations, examples of which are illustrated in the accompanying drawings. In the following detailed description, numerous specific details are set forth in order to provide a thorough understanding of the various described implementations. However, it will be apparent to one of ordinary skill in the art that the various described implementations may be practiced without these specific details. In other instances, well-known methods, procedures, components, circuits, and networks have not been described in detail so as not to unnecessarily obscure aspects of the implementations.

It will also be understood that, although the terms first, second, etc. are, in some instances, used herein to describe various elements, these elements should not be limited by these terms. These terms are only used to distinguish one element from another. For example, a first type of signal could be termed a second type of signal, and, similarly, a second type of signal could be termed a first type of signal, without departing from the scope of the various described implementations. The first type of signal and the second type of signal are both types of signals, but they are not the same type of signal.

The terminology used in the description of the various described implementations herein is for the purpose of describing particular implementations only and is not intended to be limiting. As used in the description of the various described implementations and the appended claims, the singular forms “a”, “an” and “the” are intended to include the plural forms as well, unless the context clearly indicates otherwise. It will also be understood that the term “and/or” as used herein refers to and encompasses any and all possible combinations of one or more of the associated listed items. It



will be further understood that the terms “includes,” “including,” “comprises,” and/or “comprising,” when used in this specification, specify the presence of stated features, integers, steps, operations, elements, and/or components, but do not preclude the presence or addition of one or more other features, integers, steps, operations, elements, components, and/or groups thereof.

As used herein, the term “if” is, optionally, construed to mean “when” or “upon” or “in response to determining” or “in response to detecting” or “in accordance with a determination that,” depending on the context. Similarly, the phrase “if it is determined” or “if [a stated condition or event] is detected” is, optionally, construed to mean “upon determining” or “in response to determining” or “upon detecting [the stated condition or event]” or “in response to detecting [the stated condition or event]” or “in accordance with a determination that [a stated condition or event] is detected,” depending on the context.

It is to be appreciated that “smart home environments” may refer to smart environments for homes such as a single-family house, but the scope of the present teachings is not so limited. The present teachings are also applicable, without limitation, to duplexes, townhomes, multi-unit apartment buildings, hotels, retail stores, office buildings, industrial buildings, and more generally any living space or work space.

It is also to be appreciated that while the terms user, customer, installer, homeowner, occupant, guest, tenant, landlord, repair person, and the like may be used to refer to the person or persons acting in the context of some particularly situations described herein, these references do not limit the scope of the present teachings with respect to the person or persons who are performing such actions. Thus, for example, the terms user, customer, purchaser, installer, subscriber, and homeowner may often refer to the same person in the case of a single-family residential dwelling, because the head of the household is often the person who makes the purchasing decision, buys the unit, and installs and configures the unit, and is also one of the users of the unit. However, in other scenarios, such as a landlord-tenant environment, the customer may be the landlord with respect to purchasing the unit, the installer may be a local apartment supervisor, a first user may be the tenant, and a second user may again be the landlord with respect to remote control functionality. Importantly, while the identity of the person performing the action may be germane to a particular advantage provided by one or more of the implementations, such identity should not be construed in the descriptions that follow as necessarily limiting the scope of the present teachings to those particular individuals having those particular identities.

FIG. 1 is an example smart home environment 100 in accordance with some implementations. Smart home environment 100 includes a structure 150 (e.g., a house, office building, garage, or mobile home) with various integrated devices. It will be appreciated that devices may also be integrated into a smart home environment 100 that does not include an entire structure 150, such as an apartment, condominium, or office space. Further, the smart home environment 100 may control and/or be coupled to devices outside of the actual structure 150. Indeed, several devices in the smart home environment 100 need not be physically within the structure 150. For example, a device controlling a pool heater 114 or irrigation system 116 may be located outside of the structure 150.

The depicted structure 150 includes a plurality of rooms 152, separated at least partly from each other via walls 154. The walls 154 may include interior walls or exterior walls. Each room may further include a floor 156 and a ceiling 158.

Devices may be mounted on, integrated with and/or supported by a wall 154, floor 156 or ceiling 158.

In some implementations, the integrated devices of the smart home environment 100 include intelligent, multi-sensing, network-connected devices that integrate seamlessly with each other in a smart home network (e.g., 202 FIG. 2) and/or with a central server or a cloud-computing system to provide a variety of useful smart home functions. The smart home environment 100 may include one or more intelligent, multi-sensing, network-connected thermostats 102 (hereinafter referred to as “smart thermostats 102”), one or more intelligent, network-connected, multi-sensing hazard detection units 104 (hereinafter referred to as “smart hazard detectors 104”), one or more intelligent, multi-sensing, network-connected entryway interface devices 106 and 120 (hereinafter referred to as “smart doorbells 106” and “smart door locks 120”), and one or more intelligent, multi-sensing, network-connected alarm systems 122 (hereinafter referred to as “smart alarm systems 122”).

In some implementations, the one or more smart thermostats 102 detect ambient climate characteristics (e.g., temperature and/or humidity) and control a HVAC system 103 accordingly. For example, a respective smart thermostat 102 includes an ambient temperature sensor.

The one or more smart hazard detectors 104 may include thermal radiation sensors directed at respective heat sources (e.g., a stove, oven, other appliances, a fireplace, etc.). For example, a smart hazard detector 104 in a kitchen 153 includes a thermal radiation sensor directed at a stove/oven 112. A thermal radiation sensor may determine the temperature of the respective heat source (or a portion thereof) at which it is directed and may provide corresponding black-body radiation data as output.

The smart doorbell 106 and/or the smart door lock 120 may detect a person’s approach to or departure from a location (e.g., an outer door), control doorbell/door locking functionality (e.g., receive user inputs from a portable electronic device 166-1 to actuate bolt of the smart door lock 120), announce a person’s approach or departure via audio or visual means, and/or control settings on a security system (e.g., to activate or deactivate the security system when occupants go and come).

The smart alarm system 122 may detect the presence of an individual within close proximity (e.g., using built-in IR sensors), sound an alarm (e.g., through a built-in speaker, or by sending commands to one or more external speakers), and send notifications to entities or users within/outside of the smart home network 100. In some implementations, the smart alarm system 122 also includes one or more input devices or sensors (e.g., keypad, biometric scanner, NFC transceiver, microphone) for verifying the identity of a user, and one or more output devices (e.g., display, speaker). In some implementations, the smart alarm system 122 may also be set to an “armed” mode, such that detection of a trigger condition or event causes the alarm to be sounded unless a disarming action is performed.

In some implementations, the smart home environment 100 includes one or more intelligent, multi-sensing, network-connected wall switches 108 (hereinafter referred to as “smart wall switches 108”), along with one or more intelligent, multi-sensing, network-connected wall plug interfaces 110 (hereinafter referred to as “smart wall plugs 110”). The smart wall switches 108 may detect ambient lighting conditions, detect room-occupancy states, and control a power and/or dim state of one or more lights. In some instances, smart wall switches 108 may also control a power state or speed of a fan, such as a ceiling fan. The smart wall plugs 110



may detect occupancy of a room or enclosure and control supply of power to one or more wall plugs (e.g., such that power is not supplied to the plug if nobody is at home).

In some implementations, the smart home environment **100** of FIG. **1** includes a plurality of intelligent, multi-sensing, network-connected appliances **112** (hereinafter referred to as “smart appliances **112**”), such as refrigerators, stoves, ovens, televisions, washers, dryers, lights, stereos, intercom systems, garage-door openers, floor fans, ceiling fans, wall air conditioners, pool heaters, irrigation systems, security systems, space heaters, window AC units, motorized duct vents, and so forth. In some implementations, when plugged in, an appliance may announce itself to the smart home network, such as by indicating what type of appliance it is, and it may automatically integrate with the controls of the smart home. Such communication by the appliance to the smart home may be facilitated by either a wired or wireless communication protocol. The smart home may also include a variety of non-communicating legacy appliances **140**, such as old conventional washer/dryers, refrigerators, and the like, which may be controlled by smart wall plugs **110**. The smart home environment **100** may further include a variety of partially communicating legacy appliances **142**, such as infrared (“IR”) controlled wall air conditioners or other IR-controlled devices, which may be controlled by IR signals provided by the smart hazard detectors **104** or the smart wall switches **108**.

In some implementations, the smart home environment **100** includes one or more network-connected cameras **118** that are configured to provide video monitoring and security in the smart home environment **100**. The cameras **118** may be used to determine occupancy of the structure **150** and/or particular rooms **152** in the structure **150**, and thus may act as occupancy sensors. For example, video captured by the cameras **118** may be processed to identify the presence of an occupant in the structure **150** (e.g., in a particular room **152**). Specific individuals may be identified based, for example, on their appearance (e.g., height, face) and/or movement (e.g., their walk/gait). Cameras **118** may additionally include one or more sensors (e.g., IR sensors, motion detectors), input devices (e.g., microphone for capturing audio), and output devices (e.g., speaker for outputting audio).

The smart home environment **100** may additionally or alternatively include one or more other occupancy sensors (e.g., the smart doorbell **106**, smart door locks **120**, touch screens, IR sensors, microphones, ambient light sensors, motion detectors, smart nightlights **170**, etc.). In some implementations, the smart home environment **100** includes radio-frequency identification (RFID) readers (e.g., in each room **152** or a portion thereof) that determine occupancy based on RFID tags located on or embedded in occupants. For example, RFID readers may be integrated into the smart hazard detectors **104**.

The smart home environment **100** may also include communication with devices outside of the physical home but within a proximate geographical range of the home. For example, the smart home environment **100** may include a pool heater monitor **114** that communicates a current pool temperature to other devices within the smart home environment **100** and/or receives commands for controlling the pool temperature. Similarly, the smart home environment **100** may include an irrigation monitor **116** that communicates information regarding irrigation systems within the smart home environment **100** and/or receives control information for controlling such irrigation systems.

By virtue of network connectivity, one or more of the smart home devices of FIG. **1** may further allow a user to interact with the device even if the user is not proximate to the device.

For example, a user may communicate with a device using a computer (e.g., a desktop computer, laptop computer, or tablet) or other portable electronic device **166** (e.g., a mobile phone, such as a smart phone). A webpage or application may be configured to receive communications from the user and control the device based on the communications and/or to present information about the device’s operation to the user. For example, the user may view a current set point temperature for a device (e.g., a stove) and adjust it using a computer. The user may be in the structure during this remote communication or outside the structure.

As discussed above, users may control smart devices in the smart home environment **100** using a network-connected computer or portable electronic device **166**. In some examples, some or all of the occupants (e.g., individuals who live in the home) may register their device **166** with the smart home environment **100**. Such registration may be made at a central server to authenticate the occupant and/or the device as being associated with the home and to give permission to the occupant to use the device to control the smart devices in the home. An occupant may use their registered device **166** to remotely control the smart devices of the home, such as when the occupant is at work or on vacation. The occupant may also use their registered device to control the smart devices when the occupant is actually located inside the home, such as when the occupant is sitting on a couch inside the home. It should be appreciated that instead of or in addition to registering devices **166**, the smart home environment **100** may make inferences about which individuals live in the home and are therefore occupants and which devices **166** are associated with those individuals. As such, the smart home environment may “learn” who is an occupant and permit the devices **166** associated with those individuals to control the smart devices of the home.

In some implementations, in addition to containing processing and sensing capabilities, devices **102**, **104**, **106**, **108**, **110**, **112**, **114**, **116**, **118**, **120**, and/or **122** (collectively referred to as “the smart devices”) are capable of data communications and information sharing with other smart devices, a central server or cloud-computing system, and/or other devices that are network-connected. Data communications may be carried out using any of a variety of custom or standard wireless protocols (e.g., IEEE 802.15.4, Wi-Fi, ZigBee, 6LoWPAN, Thread, Z-Wave, Bluetooth Smart, ISA100.11a, WirelessHART, MiWi, etc.) and/or any of a variety of custom or standard wired protocols (e.g., Ethernet, HomePlug, etc.), or any other suitable communication protocol, including communication protocols not yet developed as of the filing date of this document.

In some implementations, the smart devices serve as wireless or wired repeaters. In some implementations, a first one of the smart devices communicates with a second one of the smart devices via a wireless router. The smart devices may further communicate with each other via a connection (e.g., network interface **160**) to a network, such as the Internet **162**. Through the Internet **162**, the smart devices may communicate with a smart home provider server system **164** (also called a central server system and/or a cloud-computing system herein). The smart home provider server system **164** may be associated with a manufacturer, support entity, or service provider associated with the smart device(s). In some implementations, a user is able to contact customer support using a smart device itself rather than needing to use other communication means, such as a telephone or Internet-connected computer. In some implementations, software updates are automatically sent from the smart home provider server sys-



tem **164** to smart devices (e.g., when available, when purchased, or at routine intervals).

In some implementations, the network interface **160** includes a conventional network device (e.g., a router), and the smart home environment **100** of FIG. **1** includes a hub device **180** that is communicatively coupled to the network(s) **162** directly or via the network interface **160**. The hub device **180** is further communicatively coupled to one or more of the above intelligent, multi-sensing, network-connected devices (e.g., smart devices of the smart home environment **100**). Each of these smart devices optionally communicates with the hub device **180** using one or more radio communication networks available at least in the smart home environment **100** (e.g., ZigBee, Z-Wave, Insteon, Bluetooth, Wi-Fi and other radio communication networks). In some implementations, the hub device **180** and devices coupled with/to the hub device can be controlled and/or interacted with via an application running on a smart phone, household controller, laptop, tablet computer, game console or similar electronic device. In some implementations, a user of such controller application can view status of the hub device or coupled smart devices, configure the hub device to interoperate with smart devices newly introduced to the home network, commission new smart devices, and adjust or view settings of connected smart devices, etc. In some implementations the hub device extends capabilities of low capability smart device to match capabilities of the highly capable smart devices of the same type, integrates functionality of multiple different device types—even across different communication protocols, and is configured to streamline adding of new devices and commissioning of the hub device.

FIG. **2** is a block diagram illustrating an example network architecture **200** that includes a smart home network **202** in accordance with some implementations. In some implementations, the smart devices **204** in the smart home environment **100** (e.g., devices **102, 104, 106, 108, 110, 112, 114, 116, 118, 120, and/or 122**) combine with the hub device **180** to create a mesh network in smart home network **202**. In some implementations, one or more smart devices **204** in the smart home network **202** operate as a smart home controller. Additionally and/or alternatively, hub device **180** operates as the smart home controller. In some implementations, a smart home controller has more computing power than other smart devices. In some implementations, a smart home controller processes inputs (e.g., from smart devices **204**, electronic device **166**, and/or smart home provider server system **164**) and sends commands (e.g., to smart devices **204** in the smart home network **202**) to control operation of the smart home environment **100**. In some implementations, some of the smart devices **204** in the smart home network **202** (e.g., in the mesh network) are “spokesman” nodes (e.g., **204-1**) and others are “low-powered” nodes (e.g., **204-9**). Some of the smart devices in the smart home environment **100** are battery powered, while others have a regular and reliable power source, such as by connecting to wiring (e.g., to 120V line voltage wires) behind the walls **154** of the smart home environment. The smart devices that have a regular and reliable power source are referred to as “spokesman” nodes. These nodes are typically equipped with the capability of using a wireless protocol to facilitate bidirectional communication with a variety of other devices in the smart home environment **100**, as well as with the smart home provider server system **164**. In some implementations, one or more “spokesman” nodes operate as a smart home controller. On the other hand, the devices that are battery powered are the “low-power” nodes. These nodes tend to be smaller than spokesman nodes and

typically only communicate using wireless protocols that require very little power, such as Zigbee, 6LoWPAN, etc.

In some implementations, some low-power nodes are incapable of bidirectional communication. These low-power nodes send messages, but they are unable to “listen”. Thus, other devices in the smart home environment **100**, such as the spokesman nodes, cannot send information to these low-power nodes.

In some implementations, some low-power nodes are capable of only a limited bidirectional communication. For example, other devices are able to communicate with the low-power nodes only during a certain time period.

As described, in some implementations, the smart devices serve as low-power and spokesman nodes to create a mesh network in the smart home environment **100**. In some implementations, individual low-power nodes in the smart home environment regularly send out messages regarding what they are sensing, and the other low-powered nodes in the smart home environment—in addition to sending out their own messages—forward the messages, thereby causing the messages to travel from node to node (i.e., device to device) throughout the smart home network **202**. In some implementations, the spokesman nodes in the smart home network **202**, which are able to communicate using a relatively high-power communication protocol, such as IEEE 802.11, are able to switch to a relatively low-power communication protocol, such as IEEE 802.15.4, to receive these messages, translate the messages to other communication protocols, and send the translated messages to other spokesman nodes and/or the smart home provider server system **164** (using, e.g., the relatively high-power communication protocol). Thus, the low-powered nodes using low-power communication protocols are able to send and/or receive messages across the entire smart home network **202**, as well as over the Internet **162** to the smart home provider server system **164**. In some implementations, the mesh network enables the smart home provider server system **164** to regularly receive data from most or all of the smart devices in the home, make inferences based on the data, facilitate state synchronization across devices within and outside of the smart home network **202**, and send commands to one or more of the smart devices to perform tasks in the smart home environment.

As described, the spokesman nodes and some of the low-powered nodes are capable of “listening.” Accordingly, users, other devices, and/or the smart home provider server system **164** may communicate control commands to the low-powered nodes. For example, a user may use the electronic device **166** (e.g., a smart phone) to send commands over the Internet to the smart home provider server system **164**, which then relays the commands to one or more spokesman nodes in the smart home network **202**. The spokesman nodes may use a low-power protocol to communicate the commands to the low-power nodes throughout the smart home network **202**, as well as to other spokesman nodes that did not receive the commands directly from the smart home provider server system **164**.

In some implementations, a smart nightlight **170** (FIG. **1**), which is an example of a smart device **204**, is a low-power node. In addition to housing a light source, the smart nightlight **170** houses an occupancy sensor, such as an ultrasonic or passive IR sensor, and an ambient light sensor, such as a photo resistor or a single-pixel sensor that measures light in the room. In some implementations, the smart nightlight **170** is configured to activate the light source when its ambient light sensor detects that the room is dark and when its occupancy sensor detects that someone is in the room. In other implementations, the smart nightlight **170** is simply configured to



activate the light source when its ambient light sensor detects that the room is dark. Further, in some implementations, the smart nightlight **170** includes a low-power wireless communication chip (e.g., a ZigBee chip) that regularly sends out messages regarding the occupancy of the room and the amount of light in the room, including instantaneous messages coincident with the occupancy sensor detecting the presence of a person in the room. As mentioned above, these messages may be sent wirelessly (e.g., using the mesh network) from node to node (i.e., smart device to smart device) within the smart home network **202** as well as over the Internet **162** to the smart home provider server system **164**.

Other examples of low-power nodes include battery-operated versions of the smart hazard detectors **104**. These smart hazard detectors **104** are often located in an area without access to constant and reliable power and may include any number and type of sensors, such as smoke/fire/heat sensors (e.g., thermal radiation sensors), carbon monoxide/dioxide sensors, occupancy/motion sensors, ambient light sensors, ambient temperature sensors, humidity sensors, and the like. Furthermore, smart hazard detectors **104** may send messages that correspond to each of the respective sensors to the other devices and/or the smart home provider server system **164**, such as by using the mesh network as described above.

Examples of spokesman nodes include smart doorbells **106**, smart thermostats **102**, smart wall switches **108**, and smart wall plugs **110**. These devices are often located near and connected to a reliable power source, and therefore may include more power-consuming components, such as one or more communication chips capable of bidirectional communication in a variety of protocols.

In some implementations, the smart home environment **100** includes service robots **168** (FIG. 1) that are configured to carry out, in an autonomous manner, any of a variety of household tasks.

As explained above with reference to FIG. 1, in some implementations, the smart home environment **100** of FIG. 1 includes a hub device **180** that is communicatively coupled to the network(s) **162** directly or via the network interface **160**. The hub device **180** is further communicatively coupled to one or more of the smart devices using a radio communication network that is available at least in the smart home environment **100**. Communication protocols used by the radio communication network include, but are not limited to, ZigBee, Z-Wave, Insteon, EuOcean, Thread, OSIAN, Bluetooth Low Energy and the like. In some implementations, the hub device **180** not only converts the data received from each smart device to meet the data format requirements of the network interface **160** or the network(s) **162**, but also converts information received from the network interface **160** or the network(s) **162** to meet the data format requirements of the respective communication protocol associated with a targeted smart device. In some implementations, in addition to data format conversion, the hub device **180** further processes the data received from the smart devices or information received from the network interface **160** or the network(s) **162** preliminary. For example, the hub device **180** can integrate inputs from multiple sensors/connected devices (including sensors/devices of the same and/or different types), perform higher level processing on those inputs—e.g., to assess the overall environment and coordinate operation among the different sensors/devices—and/or provide instructions to the different devices based on the collection of inputs and programmed processing. It is also noted that in some implementations, the network interface **160** and the hub device **180** are integrated to one network device. Functionality described herein is representative of particular implementations of smart devices, con-

trol application(s) running on representative electronic device(s) (such as a smart phone), hub device(s) **180**, and server(s) coupled to hub device(s) via the Internet or other Wide Area Network. All or a portion of this functionality and associated operations can be performed by any elements of the described system—for example, all or a portion of the functionality described herein as being performed by an implementation of the hub device can be performed, in different system implementations, in whole or in part on the server, one or more connected smart devices and/or the control application, or different combinations thereof.

FIG. 3 illustrates a network-level view of an extensible devices and services platform with which the smart home environment of FIG. 1 is integrated, in accordance with some implementations. The extensible devices and services platform **300** includes smart home provider server system **164**. Each of the intelligent, network-connected devices described with reference to FIG. 1 (e.g., **102**, **104**, **106**, **108**, **110**, **112**, **114**, **116** and **118**, identified simply as “devices” in FIGS. 2-4) may communicate with the smart home provider server system **164**. For example, a connection to the Internet **162** may be established either directly (for example, using 3G/4G connectivity to a wireless carrier), or through a network interface **160** (e.g., a router, switch, gateway, hub device, or an intelligent, dedicated whole-home controller node), or through any combination thereof.

In some implementations, the devices and services platform **300** communicates with and collects data from the smart devices of the smart home environment **100**. In addition, in some implementations, the devices and services platform **300** communicates with and collects data from a plurality of smart home environments across the world. For example, the smart home provider server system **164** collects home data **302** from the devices of one or more smart home environments **100**, where the devices may routinely transmit home data or may transmit home data in specific instances (e.g., when a device queries the home data **302**). Example collected home data **302** includes, without limitation, power consumption data, blackbody radiation data, occupancy data, HVAC settings and usage data, carbon monoxide levels data, carbon dioxide levels data, volatile organic compounds levels data, sleeping schedule data, cooking schedule data, inside and outside temperature humidity data, television viewership data, inside and outside noise level data, pressure data, video data, etc.

In some implementations, the smart home provider server system **164** provides one or more services **304** to smart homes and/or third parties. Example services **304** include, without limitation, software updates, customer support, sensor data collection/logging, remote access, remote or distributed control, and/or use suggestions (e.g., based on collected home data **302**) to improve performance, reduce utility cost, increase safety, etc. In some implementations, data associated with the services **304** is stored at the smart home provider server system **164**, and the smart home provider server system **164** retrieves and transmits the data at appropriate times (e.g., at regular intervals, upon receiving a request from a user, etc.).

In some implementations, the extensible devices and services platform **300** includes a processing engine **306**, which may be concentrated at a single server or distributed among several different computing entities without limitation. In some implementations, the processing engine **306** includes engines configured to receive data from the devices of smart home environments **100** (e.g., via the Internet **162** and/or a network interface **160**), to index the data, to analyze the data and/or to generate statistics based on the analysis or as part of



the analysis. In some implementations, the analyzed data is stored as derived home data **308**.

Results of the analysis or statistics may thereafter be transmitted back to the device that provided home data used to derive the results, to other devices, to a server providing a webpage to a user of the device, or to other non-smart device entities. In some implementations, usage statistics, usage statistics relative to use of other devices, usage patterns, and/or statistics summarizing sensor readings are generated by the processing engine **306** and transmitted. The results or statistics may be provided via the Internet **162**. In this manner, the processing engine **306** may be configured and programmed to derive a variety of useful information from the home data **302**. A single server may include one or more processing engines.

The derived home data **308** may be used at different granularities for a variety of useful purposes, ranging from explicit programmed control of the devices on a per-home, per-neighborhood, or per-region basis (for example, demand-response programs for electrical utilities), to the generation of inferential abstractions that may assist on a per-home basis (for example, an inference may be drawn that the homeowner has left for vacation and so security detection equipment may be put on heightened sensitivity), to the generation of statistics and associated inferential abstractions that may be used for government or charitable purposes. For example, processing engine **306** may generate statistics about device usage across a population of devices and send the statistics to device users, service providers or other entities (e.g., entities that have requested the statistics and/or entities that have provided monetary compensation for the statistics).

In some implementations, to encourage innovation and research and to increase products and services available to users, the devices and services platform **300** exposes a range of application programming interfaces (APIs) **310** to third parties, such as charities **314**, governmental entities **316** (e.g., the Food and Drug Administration or the Environmental Protection Agency), academic institutions **318** (e.g., university researchers), businesses **320** (e.g., providing device warranties or service to related equipment, targeting advertisements based on home data), utility companies **324**, and other third parties. The APIs **310** are coupled to and permit third-party systems to communicate with the smart home provider server system **164**, including the services **304**, the processing engine **306**, the home data **302**, and the derived home data **308**. In some implementations, the APIs **310** allow applications executed by the third parties to initiate specific data processing tasks that are executed by the smart home provider server system **164**, as well as to receive dynamic updates to the home data **302** and the derived home data **308**.

For example, third parties may develop programs and/or applications (e.g., web applications or mobile applications) that integrate with the smart home provider server system **164** to provide services and information to users. Such programs and applications may be, for example, designed to help users reduce energy consumption, to preemptively service faulty equipment, to prepare for high service demands, to track past service performance, etc., and/or to perform other beneficial functions or tasks.

FIG. 4 illustrates an abstracted functional view **400** of the extensible devices and services platform **300** of FIG. 3, with reference to a processing engine **306** as well as devices of the smart home environment, in accordance with some implementations. Even though devices situated in smart home environments will have a wide variety of different individual capabilities and limitations, the devices may be thought of as sharing common characteristics in that each device is a data consumer **402** (DC), a data source **404** (DS), a services con-

sumer **406** (SC), and a services source **408** (SS). Advantageously, in addition to providing control information used by the devices to achieve their local and immediate objectives, the extensible devices and services platform **300** may also be configured to use the large amount of data that is generated by these devices. In addition to enhancing or optimizing the actual operation of the devices themselves with respect to their immediate functions, the extensible devices and services platform **300** may be directed to “repurpose” that data in a variety of automated, extensible, flexible, and/or scalable ways to achieve a variety of useful objectives. These objectives may be predefined or adaptively identified based on, e.g., usage patterns, device efficiency, and/or user input (e.g., requesting specific functionality).

FIG. 4 shows processing engine **306** as including a number of processing paradigms **410**. In some implementations, processing engine **306** includes a managed services paradigm **410a** that monitors and manages primary or secondary device functions. The device functions may include ensuring proper operation of a device given user inputs, estimating that (e.g., and responding to an instance in which) an intruder is or is attempting to be in a dwelling, detecting a failure of equipment coupled to the device (e.g., a light bulb having burned out), implementing or otherwise responding to energy demand response events, providing a heat-source alert, and/or alerting a user of a current or predicted future event or characteristic. In some implementations, processing engine **306** includes an advertising/communication paradigm **410b** that estimates characteristics (e.g., demographic information), desires and/or products of interest of a user based on device usage. Services, promotions, products or upgrades may then be offered or automatically provided to the user. In some implementations, processing engine **306** includes a social paradigm **410c** that uses information from a social network, provides information to a social network (for example, based on device usage), and/or processes data associated with user and/or device interactions with the social network platform. For example, a user’s status as reported to their trusted contacts on the social network may be updated to indicate when the user is home based on light detection, security system inactivation or device usage detectors. As another example, a user may be able to share device-usage statistics with other users. In yet another example, a user may share HVAC settings that result in low power bills and other users may download the HVAC settings to their smart thermostat **102** to reduce their power bills.

In some implementations, processing engine **306** includes a challenges/rules/compliance/rewards paradigm **410d** that informs a user of challenges, competitions, rules, compliance regulations and/or rewards and/or that uses operation data to determine whether a challenge has been met, a rule or regulation has been complied with and/or a reward has been earned. The challenges, rules, and/or regulations may relate to efforts to conserve energy, to live safely (e.g., reducing the occurrence of heat-source alerts) (e.g., reducing exposure to toxins or carcinogens), to conserve money and/or equipment life, to improve health, etc. For example, one challenge may involve participants turning down their thermostat by one degree for one week. Those participants that successfully complete the challenge are rewarded, such as with coupons, virtual currency, status, etc. Regarding compliance, an example involves a rental-property owner making a rule that no renters are permitted to access certain owner’s rooms. The devices in the room having occupancy sensors may send updates to the owner when the room is accessed.

In some implementations, processing engine **306** integrates or otherwise uses extrinsic information **412** from



extrinsic sources to improve the functioning of one or more processing paradigms. Extrinsic information **412** may be used to interpret data received from a device, to determine a characteristic of the environment near the device (e.g., outside a structure that the device is enclosed in), to determine services or products available to the user, to identify a social network or social-network information, to determine contact information of entities (e.g., public-service entities such as an emergency-response team, the police or a hospital) near the device, to identify statistical or environmental conditions, trends or other information associated with a home or neighborhood, and so forth.

FIG. **5** illustrates a representative operating environment **500** in which a hub device server system **508** provides data processing for monitoring and facilitating review of motion events in video streams captured by video cameras **118**. As shown in FIG. **5**, the hub device server system **508** receives video data from video sources **522** (including cameras **118**) located at various physical locations (e.g., inside homes, restaurants, stores, streets, parking lots, and/or the smart home environments **100** of FIG. **1**). Each video source **522** may be bound to one or more reviewer accounts, and the hub device server system **508** provides video monitoring data for the video source **522** to client devices **504** associated with the reviewer accounts. For example, the portable electronic device **166** is an example of the client device **504**.

In some implementations, the smart home provider server system **164** or a component thereof serves as the hub device server system **508**. In some implementations, the hub device server system **508** is a dedicated video processing server that provides video processing services to video sources and client devices **504** independent of other services provided by the hub device server system **508**.

In some implementations, each of the video sources **522** includes one or more video cameras **118** that capture video and send the captured video to the hub device server system **508** substantially in real-time. In some implementations, each of the video sources **522** optionally includes a controller device (not shown) that serves as an intermediary between the one or more cameras **118** and the hub device server system **508**. The controller device receives the video data from the one or more cameras **118**, optionally, performs some preliminary processing on the video data, and sends the video data to the hub device server system **508** on behalf of the one or more cameras **118** substantially in real-time. In some implementations, each camera has its own on-board processing capabilities to perform some preliminary processing on the captured video data before sending the processed video data (along with metadata obtained through the preliminary processing) to the controller device and/or the hub device server system **508**.

As shown in FIG. **5**, in accordance with some implementations, each of the client devices **504** includes a client-side module **502**. The client-side module **502** communicates with a server-side module **506** executed on the hub device server system **508** through the one or more networks **162**. The client-side module **502** provides client-side functionalities for the event monitoring and review processing and communications with the server-side module **506**. The server-side module **506** provides server-side functionalities for event monitoring and review processing for any number of client-side modules **502** each residing on a respective client device **504**. The server-side module **506** also provides server-side functionalities for video processing and camera control for any number of the video sources **522**, including any number of control devices and the cameras **118**.

In some implementations, the server-side module **506** includes one or more processors **512**, a video storage database **514**, device and account databases **516**, an I/O interface to one or more client devices **518**, and an I/O interface to one or more video sources **520**. The I/O interface to one or more clients **518** facilitates the client-facing input and output processing for the server-side module **506**. The databases **516** store a plurality of profiles for reviewer accounts registered with the video processing server, where a respective user profile includes account credentials for a respective reviewer account, and one or more video sources linked to the respective reviewer account. The I/O interface to one or more video sources **520** facilitates communications with one or more video sources **522** (e.g., groups of one or more cameras **118** and associated controller devices). The video storage database **514** stores raw video data received from the video sources **522**, as well as various types of metadata, such as motion events, event categories, event category models, event filters, and event masks, for use in data processing for event monitoring and review for each reviewer account.

Examples of a representative client device **504** include, but are not limited to, a handheld computer, a wearable computing device, a personal digital assistant (PDA), a tablet computer, a laptop computer, a desktop computer, a cellular telephone, a smart phone, an enhanced general packet radio service (EGPRS) mobile phone, a media player, a navigation device, a game console, a television, a remote control, a point-of-sale (POS) terminal, vehicle-mounted computer, an ebook reader, or a combination of any two or more of these data processing devices or other data processing devices.

Examples of the one or more networks **162** include local area networks (LAN) and wide area networks (WAN) such as the Internet. The one or more networks **162** are, optionally, implemented using any known network protocol, including various wired or wireless protocols, such as Ethernet, Universal Serial Bus (USB), FIREWIRE, Long Term Evolution (LTE), Global System for Mobile Communications (GSM), Enhanced Data GSM Environment (EDGE), code division multiple access (CDMA), time division multiple access (TDMA), Bluetooth, Wi-Fi, voice over Internet Protocol (VoIP), Wi-MAX, or any other suitable communication protocol.

In some implementations, the hub device server system **508** is implemented on one or more standalone data processing apparatuses or a distributed network of computers. In some implementations, the hub device server system **508** also employs various virtual devices and/or services of third party service providers (e.g., third-party cloud service providers) to provide the underlying computing resources and/or infrastructure resources of the hub device server system **508**. In some implementations, the hub device server system **508** includes, but is not limited to, a handheld computer, a tablet computer, a laptop computer, a desktop computer, or a combination of any two or more of these data processing devices or other data processing devices.

The server-client environment **500** shown in FIG. **1** includes both a client-side portion (e.g., the client-side module **502**) and a server-side portion (e.g., the server-side module **506**). The division of functionalities between the client and server portions of operating environment **500** can vary in different implementations. Similarly, the division of functionalities between the video source **522** and the hub device server system **508** can vary in different implementations. For example, in some implementations, client-side module **502** is a thin-client that provides only user-facing input and output processing functions, and delegates all other data processing functionalities to a backend server (e.g., the hub device server



system **508**). Similarly, in some implementations, a respective one of the video sources **522** is a simple video capturing device that continuously captures and streams video data to the hub device server system **508** without no or limited local preliminary processing on the video data. Although many aspects of the present technology are described from the perspective of the hub device server system **508**, the corresponding actions performed by the client device **504** and/or the video sources **522** would be apparent to ones skilled in the art without any creative efforts. Similarly, some aspects of the present technology may be described from the perspective of the client device or the video source, and the corresponding actions performed by the video server would be apparent to ones skilled in the art without any creative efforts. Furthermore, some aspects of the present technology may be performed by the hub device server system **508**, the client device **504**, and the video sources **522** cooperatively.

It should be understood that operating environment **500** that involves the hub device server system **508**, the video sources **522** and the video cameras **118** is merely an example. Many aspects of operating environment **500** are generally applicable in other operating environments in which a server system provides data processing for monitoring and facilitating review of data captured by other types of electronic devices (e.g., smart thermostats **102**, smart hazard detectors **104**, smart doorbells **106**, smart wall plugs **110**, appliances **112** and the like).

The electronic devices, the client devices or the server system communicate with each other using the one or more communication networks **162**. In an example smart home environment, two or more devices (e.g., the network interface device **160**, the hub device **180**, and the client devices **504-m**) are located in close proximity to each other, such that they could be communicatively coupled in the same sub-network **162A** via wired connections, a WLAN or a Bluetooth Personal Area Network (PAN). The Bluetooth PAN is optionally established based on classical Bluetooth technology or Bluetooth Low Energy (BLE) technology. This smart home environment further includes one or more other radio communication networks **162B** through which at least some of the electronic devices of the video sources **522-n** exchange data with the hub device **180**. Alternatively, in some situations, some of the electronic devices of the video sources **522-n** communicate with the network interface device **160** directly via the same sub-network **162A** that couples devices **160**, **180** and **504-m**. In some implementations (e.g., in the network **162C**), both the client device **504-m** and the electronic devices of the video sources **522-n** communicate directly via the network(s) **162** without passing the network interface device **160** or the hub device **180**.

In some implementations, during normal operation, the network interface device **160** and the hub device **180** communicate with each other to form a network gateway through which data are exchanged with the electronic device of the video sources **522-n**. As explained above, the network interface device **160** and the hub device **180** optionally communicate with each other via a sub-network **162A**.

FIG. **6** is a block diagram illustrating a representative hub device **180** in accordance with some implementations. In some implementations, the hub device **180** includes one or more processing units (e.g., CPUs, ASICs, FPGAs, microprocessors, and the like) **602**, one or more communication interfaces **604**, memory **606**, radios **640**, and one or more communication buses **608** for interconnecting these components (sometimes called a chipset). In some implementations, the hub device **180** includes one or more input devices **610** such as one or more buttons for receiving input. In some

implementations, the hub device **180** includes one or more output devices **612** such as one or more indicator lights, a sound card, a speaker, a small display for displaying textual information and error codes, etc. Furthermore, in some implementations, the hub device **180** uses a microphone and voice recognition or a camera and gesture recognition to supplement or replace the keyboard. In some implementations, the hub device **180** includes a location detection device **614**, such as a GPS (global positioning satellite) or other geo-location receiver, for determining the location of the hub device **180**.

The hub device **180** optionally includes one or more built-in sensors (not shown), including, for example, one or more thermal radiation sensors, ambient temperature sensors, humidity sensors, IR sensors, occupancy sensors (e.g., using RFID sensors), ambient light sensors, motion detectors, accelerometers, and/or gyroscopes.

The radios **640** enable and/or connect to one or more radio communication networks in the smart home environments, and allow a hub device to communicate with smart devices **204**. In some implementations, the radios **640** are capable of data communications using any of a variety of custom or standard wireless protocols (e.g., IEEE 802.15.4, Wi-Fi, ZigBee, 6LoWPAN, Thread, Z-Wave, Bluetooth Smart, ISA100.11a, WirelessHART, MiWi, etc.) custom or standard wired protocols (e.g., Ethernet, HomePlug, etc.), and/or any other suitable communication protocol, including communication protocols not yet developed as of the filing date of this document. In some implementations, the radios **640** include multiple different physical radios, each of which implements a different communication protocol. For example, in some implementations the radios **640** include a Wi-Fi radio, a Bluetooth radio and an IEEE 802.15.4 radio, all of which operate at 2.4 GHz. In some implementations, some of the radios are combined. For example, in some implementations, a Bluetooth radio and a Wi-Fi radio are incorporated in a single chip coupled to a single antenna. In other implementations, a Bluetooth radio and an IEEE 802.15.4 radio are incorporated in a single chip coupled to a single antenna. Any combination of these radios can be implemented in any of the smart devices employed in a smart home environment.

Communication interfaces **604** include, for example, hardware capable of interfacing the one or more radios **640** with the hub device **180**, so as to enable data communications using any of a variety of custom or standard wireless protocols (e.g., IEEE 802.15.4, Wi-Fi, ZigBee, 6LoWPAN, Thread, Z-Wave, Bluetooth Smart, ISA100.11a, WirelessHART, MiWi, etc.) and/or any of a variety of custom or standard wired protocols (e.g., Ethernet, HomePlug, etc.), or any other suitable communication protocol, including communication protocols not yet developed as of the filing date of this document.

Memory **606** includes high-speed random access memory, such as DRAM, SRAM, DDR RAM, or other random access solid state memory devices; and, optionally, includes non-volatile memory, such as one or more magnetic disk storage devices, one or more optical disk storage devices, one or more flash memory devices, or one or more other non-volatile solid state storage devices. Memory **606**, or alternatively the non-volatile memory within memory **606**, includes a non-transitory computer readable storage medium. In some implementations, memory **606**, or the non-transitory computer readable storage medium of memory **606**, stores the following programs, modules, and data structures, or a subset or superset thereof:

Operating logic **616** including procedures for handling various basic system services and for performing hardware dependent tasks;



## 19

Hub device communication module **618** for connecting to and communicating with other network devices (e.g., network interface **160**, such as a router that provides Internet connectivity, networked storage devices, network routing devices, server system **508**, etc.) connected to one or more networks **162** via one or more communication interfaces **604** (wired or wireless);

Radio Communication Module **620** for connecting the hub device **180** to other devices (e.g., controller devices, smart devices **204** in smart home environment **100**, client devices **504**) via one or more radio communication devices (e.g., radios **640**);

User interface module **622** for providing and displaying a user interface in which settings, captured data, and/or other data for one or more devices (e.g., smart devices **204** in smart home environment **100**) can be configured and/or viewed; and

Hub device database **624**, including but not limited to:

Sensor information **6240** for storing and managing data received, detected, and/or transmitted by one or more sensors of the hub device **180** and/or one or more other devices (e.g., smart devices **204** in smart home environment **100**);

Device settings **6242** for storing operational settings for one or more devices (e.g., coupled smart devices **204** in smart home environment **100**); and

Communication protocol information **6244** for storing and managing protocol information for one or more protocols (e.g., standard wireless protocols, such as ZigBee, Z-Wave, etc., and/or custom or standard wired protocols, such as Ethernet).

Each of the above identified elements (e.g., modules stored in memory **206** of hub device **180**) may be stored in one or more of the previously mentioned memory devices (e.g., the memory of any of the smart devices in smart home environment **100**, FIG. 1), and corresponds to a set of instructions for performing a function described above. The above identified modules or programs (i.e., sets of instructions) need not be implemented as separate software programs, procedures, or modules, and thus various subsets of these modules may be combined or otherwise re-arranged in various implementations. In some implementations, memory **606**, optionally, stores a subset of the modules and data structures identified above. Furthermore, memory **606**, optionally, stores additional modules and data structures not described above.

FIG. 7 is a block diagram illustrating the hub server system **508** in accordance with some implementations. The hub server system **508**, typically, includes one or more processing units (CPUs) **702**, one or more network interfaces **704** (e.g., including an I/O interface to one or more client devices and an I/O interface to one or more electronic devices), memory **706**, and one or more communication buses **708** for interconnecting these components (sometimes called a chipset). Memory **706** includes high-speed random access memory, such as DRAM, SRAM, DDR RAM, or other random access solid state memory devices; and, optionally, includes non-volatile memory, such as one or more magnetic disk storage devices, one or more optical disk storage devices, one or more flash memory devices, or one or more other non-volatile solid state storage devices. Memory **706**, optionally, includes one or more storage devices remotely located from one or more processing units **702**. Memory **706**, or alternatively the non-volatile memory within memory **706**, includes a non-transitory computer readable storage medium. In some implementations, memory **706**, or the non-transitory computer readable

## 20

storage medium of memory **706**, stores the following programs, modules, and data structures, or a subset or superset thereof:

Operating system **710** including procedures for handling various basic system services and for performing hardware dependent tasks;

Network communication module **712** for connecting the hub server system **508** to other systems and devices (e.g., client devices, electronic devices, and systems connected to one or more networks **162**, FIGS. 1-5) via one or more network interfaces **704** (wired or wireless);

Server-side module **714**, which provides server-side functionalities for device control, data processing and data review, including but not limited to:

Data receiving module **7140** for receiving data from electronic devices (e.g., video data from a camera **118**, FIG. 1) via the hub device **180**, and preparing the received data for further processing and storage in the data storage database **7160**;

Hub and device control module **7142** for generating and sending server-initiated control commands to modify operation modes of electronic devices (e.g., devices of a smart home environment **100**), and/or receiving (e.g., from client devices **504**) and forwarding user-initiated control commands to modify operation modes of the electronic devices;

Data processing module **7144** for processing the data provided by the electronic devices, and/or preparing and sending processed data to a device for review (e.g., client devices **504** for review by a user); and

Server database **716**, including but not limited to:

Data storage database **7160** for storing data associated with each electronic device (e.g., each camera) of each user account, as well as data processing models, processed data results, and other relevant metadata (e.g., names of data results, location of electronic device, creation time, duration, settings of the electronic device, etc.) associated with the data, wherein (optionally) all or a portion of the data and/or processing associated with the hub device **180** or smart devices are stored securely;

Account database **7162** for storing account information for user accounts, including user account information, information and settings for linked hub devices and electronic devices (e.g., hub device identifications), hub device specific secrets, relevant user and hardware characteristics (e.g., service tier, device model, storage capacity, processing capabilities, etc.), user interface settings, data review preferences, etc., where the information for associated electronic devices includes, but is not limited to, one or more device identifiers (e.g., MAC address and UUID), device specific secrets, and displayed titles; and

Device Information Database **7164** for storing device information related to one or more hub devices, e.g., device identifiers and hub device specific secrets, independently of whether the corresponding hub devices have been associated with any user account.

Each of the above identified elements may be stored in one or more of the previously mentioned memory devices, and corresponds to a set of instructions for performing a function described above. The above identified modules or programs (i.e., sets of instructions) need not be implemented as separate software programs, procedures, or modules, and thus various subsets of these modules may be combined or otherwise re-arranged in various implementations. In some implementations, memory **706**, optionally, stores a subset of the mod-



## 21

ules and data structures identified above. Furthermore, memory 706, optionally, stores additional modules and data structures not described above.

FIG. 8 is a block diagram illustrating a representative client device 504 associated with a user account in accordance with some implementations. The client device 504, typically, includes one or more processing units (CPUs) 802, one or more network interfaces 804, memory 806, and one or more communication buses 808 for interconnecting these components (sometimes called a chipset). Optionally, the client device also includes a user interface 810 and one or more built-in sensors 890 (e.g., accelerometer and gyroscope). User interface 810 includes one or more output devices 812 that enable presentation of media content, including one or more speakers and/or one or more visual displays. User interface 810 also includes one or more input devices 814, including user interface components that facilitate user input such as a keyboard, a mouse, a voice-command input unit or microphone, a touch screen display, a touch-sensitive input pad, a gesture capturing camera, or other input buttons or controls. Furthermore, some the client devices use a microphone and voice recognition or a camera and gesture recognition to supplement or replace the keyboard. In some implementations, the client device includes one or more cameras, scanners, or photo sensor units for capturing images (not shown). Optionally, the client device includes a location detection device 816, such as a GPS (global positioning satellite) or other geo-location receiver, for determining the location of the client device.

Memory 806 includes high-speed random access memory, such as DRAM, SRAM, DDR RAM, or other random access solid state memory devices; and, optionally, includes non-volatile memory, such as one or more magnetic disk storage devices, one or more optical disk storage devices, one or more flash memory devices, or one or more other non-volatile solid state storage devices. Memory 806, optionally, includes one or more storage devices remotely located from one or more processing units 802. Memory 806, or alternatively the non-volatile memory within memory 806, includes a non-transitory computer readable storage medium. In some implementations, memory 806, or the non-transitory computer readable storage medium of memory 806, stores the following programs, modules, and data structures, or a subset or superset thereof:

- Operating system 818 including procedures for handling various basic system services and for performing hardware dependent tasks;

- Network communication module 820 for connecting the client device 504 to other systems and devices (e.g., client devices, electronic devices, and systems connected to one or more networks 162, FIGS. 1-5) via one or more network interfaces 804 (wired or wireless);

- Input processing module 822 for detecting one or more user inputs or interactions from one of the one or more input devices 814 and interpreting the detected input or interaction;

- One or more applications 824 for execution by the client device (e.g., games, social network applications, smart home applications, and/or other web or non-web based applications) for controlling devices (e.g., sending commands, configuring settings, etc. to hub devices and/or other client or electronic devices) and for reviewing data captured by the devices (e.g., device status and settings, captured data, or other information regarding the hub device or other connected devices);

- User interface module 622 for providing and displaying a user interface in which settings, captured data, and/or

## 22

other data for one or more devices (e.g., smart devices 204 in smart home environment 100) can be configured and/or viewed;

- Client-side module 828, which provides client-side functionalities for device control, data processing and data review, including but not limited to:

- Hub device and device control module 8280 for generating control commands for modifying an operating mode of the hub device or the electronic devices in accordance with user inputs; and

- Data review module 8282 for providing user interfaces for reviewing data processed by the hub server system 508; and

- Client data 830 storing data associated with the user account and electronic devices, including, but is not limited to:

- Account data 8300 storing information related to both user accounts loaded on the client device and electronic devices (e.g., of the video sources 522) associated with the user accounts, wherein such information includes cached login credentials, hub device identifiers (e.g., MAC addresses and UUIDs), electronic device identifiers (e.g., MAC addresses and UUIDs), user interface settings, display preferences, authentication tokens and tags, password keys, etc.; and

- Local data storage database 8302 for selectively storing raw or processed data associated with electronic devices (e.g., of the video sources 522, such as a camera 118).

Each of the above identified elements may be stored in one or more of the previously mentioned memory devices, and corresponds to a set of instructions for performing a function described above. The above identified modules or programs (i.e., sets of instructions) need not be implemented as separate software programs, procedures, modules or data structures, and thus various subsets of these modules may be combined or otherwise re-arranged in various implementations. In some implementations, memory 806, optionally, stores a subset of the modules and data structures identified above. Furthermore, memory 806, optionally, stores additional modules and data structures not described above.

FIG. 9 is a block diagram illustrating a representative smart device 204 in accordance with some implementations. In some implementations, the smart device 204 (e.g., any device of a smart home environment 100 (FIGS. 1 and 2), such as a camera 118, a smart hazard detector 104, a smart thermostat 102, hub device 180, etc.) includes one or more processing units (e.g., CPUs, ASICs, FPGAs, microprocessors, and the like) 902, memory 906, a communications module 942 that includes one or more radios 940 and radios 950, communication interfaces 904, and one or more communication buses 908 for interconnecting these components (sometimes called a chipset). In some implementations, user interface 910 includes one or more output devices 912 that enable presentation of media content, including one or more speakers and/or one or more visual displays. In some implementations, user interface 910 also includes one or more input devices 914, including user interface components that facilitate user input such as a keyboard, a mouse, a voice-command input unit or microphone, a touch screen display, a touch-sensitive input pad, a gesture capturing camera, or other input buttons or controls. Furthermore, some smart devices 204 use a microphone and voice recognition or a camera and gesture recognition to supplement or replace the keyboard. In some implementations, the smart device 204 includes one or more image/video capture devices 918 (e.g., cameras, video cameras, scanners, photo sensor units). Optionally, the client device



includes a location detection device **916**, such as a GPS (global positioning satellite) or other geo-location receiver, for determining the location of the smart device **204**.

The built-in sensors **990** include, for example, one or more thermal radiation sensors, ambient temperature sensors, humidity sensors, IR sensors, occupancy sensors (e.g., using RFID sensors), ambient light sensors, motion detectors, accelerometers, and/or gyroscopes.

The radio(s) **940** and radio(s) **950** enable one or more radio communication networks in the smart home environments, and allow a smart device **204** to communicate with other devices. In some implementations, the radios **940** are capable of data communications using any of a variety of custom or standard wireless protocols (e.g., IEEE 802.15.4, Wi-Fi, ZigBee, 6LoWPAN, Thread, Z-Wave, Bluetooth Smart, ISA100.11a, WirelessHART, MiWi, etc.) custom or standard wired protocols (e.g., Ethernet, HomePlug, etc.), and/or any other suitable communication protocol, including communication protocols not yet developed as of the filing date of this document.

Communication interfaces **950** include, for example, hardware capable of interfacing the one or more radios **940** and **950** with the smart device **204**, so as to enable data communications using any of a variety of custom or standard wireless protocols (e.g., IEEE 802.15.4, Wi-Fi, ZigBee, 6LoWPAN, Thread, Z-Wave, Bluetooth Smart, ISA100.11a, WirelessHART, MiWi, etc.) and/or any of a variety of custom or standard wired protocols (e.g., Ethernet, HomePlug, etc.), or any other suitable communication protocol, including communication protocols not yet developed as of the filing date of this document. In some implementations, each radio(s) **940** and radio(s) **950** has a respective communication interface **950** for facilitating and managing data communications for the respective radio, while in other implementations, multiple radios **940** and/or **950** are managed by a single respective communication interface **950**.

In some implementations, radios **940** and/or radios **950** are configured to transmit and receive the same or distinct types of signals in the smart home environment. For example, radios **940** may include transceivers configured to transmit data between other devices (e.g., smart devices) within the smart home environment (e.g., IEEE 802.15.4 communications protocol for unilaterally/bilaterally transmitting data between and among smart devices). Signals transmitted between devices may include, for example, signals directed to critical hazard information (e.g., pings indicating the detection of smoke) or device status information (e.g., ping indicating low battery). In contrast, in some implementations, the radios **950** may include transceivers configured to transmit high-bandwidth data across data networks (e.g., IEEE 802.11 (Wi-Fi) for uploading a video stream to a smart home provider server system **164**). In some implementations, the radios **940** and/or the radios **950** include transceivers configured for close-range communications with devices (e.g., Bluetooth communications protocol for device provisioning). In some implementations, the radios **940** and/or the radios **950** include transceivers configured to transmit low-power signals (e.g., smart hazard detectors **104** not connected to a persistent power source). In some implementations, radios **940** and/or radios **950** are configured to transmit multiple types of signals in the smart home environment (e.g., a Wi-Fi radio **950** uploads video stream data to the smart home provider server system **164**, in addition to routing received beacons to other nearby smart devices). In some implementations, the radios **940** and/or the radios **950** of a respective device include transceivers for directly and communicably bridging the respective device to other devices (e.g., pairing

devices directly via Bluetooth, rather than communicating via a router by using Wi-Fi). In some implementations, the radios **940** and/or the radios **950** are configured to translate signals received through a first radio **940**, and further to re-transmit the translated signals using the first radio **940** and/or a radio **950** (e.g., a proprietary message format is received via Bluetooth and translated, where the translated messages are re-transmitted to other devices using Wi-Fi).

The communications module **942** includes a variety of components for enabling the receiving and transmitting of signals by a respective smart device **204**, including one or more amplifiers, oscillators, antennas, filters, switches, memory, firmware, and/or any other support circuits or circuit components. In some implementations, the one or more radios **940** and radios **950** are integrated components of the communications module **942** (e.g., System on a Chip (SOC)). In some implementations, the one or more radios **940** and radios **950** have respective circuit components (e.g., radios **940** having a corresponding antenna **1402-1**, radios **950** having a corresponding antenna **1402-2**). Alternatively, the one or more radios **940** and radios **950** share one or more circuit components (e.g., radio **950-1** and radio **950-2** sharing an antenna **1402-2**, FIG. **15B**).

Memory **906** includes high-speed random access memory, such as DRAM, SRAM, DDR RAM, or other random access solid state memory devices; and, optionally, includes non-volatile memory, such as one or more magnetic disk storage devices, one or more optical disk storage devices, one or more flash memory devices, or one or more other non-volatile solid state storage devices. Memory **906**, or alternatively the non-volatile memory within memory **906**, includes a non-transitory computer readable storage medium. In some implementations, memory **906**, or the non-transitory computer readable storage medium of memory **906**, stores the following programs, modules, and data structures, or a subset or superset thereof:

- Operating logic **920** including procedures for handling various basic system services and for performing hardware dependent tasks;
- Device communication module **922** for connecting to and communicating with other network devices (e.g., network interface **160**, such as a router that provides Internet connectivity, networked storage devices, network routing devices, server system **508**, etc.) connected to one or more networks **162** via one or more communication interfaces **904** (wired or wireless);
- Radio Communication Module **924** for connecting the smart device **204** to other devices (e.g., controller devices, smart devices **204** in smart home environment **100**, client devices **504**) via one or more radio communication devices (e.g., radios **940**);
- Input processing module **926** for detecting one or more user inputs or interactions from the one or more input devices **914** and interpreting the detected inputs or interactions;
- User interface module **928** for providing and displaying a user interface in which settings, captured data, and/or other data for one or more devices (e.g., the smart device **204**, and/or other devices in smart home environment **100**) can be configured and/or viewed;
- One or more applications **930** for execution by the smart device **930** (e.g., games, social network applications, smart home applications, and/or other web or non-web based applications) for controlling devices (e.g., executing commands, sending commands, and/or configuring settings of the smart device **204** and/or other client/electronic devices), and for reviewing data captured by



devices (e.g., device status and settings, captured data, or other information regarding the smart device **204** and/or other client/electronic devices);

Device-side module **932**, which provides device-side functionalities for device control, data processing and data review, including but not limited to:

Command receiving module **9320** for receiving, forwarding, and/or executing instructions and control commands (e.g., from a client device **504**, from a smart home provider server system **164**, from user inputs detected on the user interface **910**, etc.) for operating the smart device **204**; and

Data processing module **9322** for processing data captured or received by one or more inputs (e.g., input devices **914**, image/video capture devices **918**, location detection device **916**), sensors (e.g., built-in sensors **990**), interfaces (e.g., communication interfaces **904**, radios **940**), and/or other components of the smart device **204**, and for preparing and sending processed data to a device for review (e.g., client devices **504** for review by a user);

Device data **934** storing data associated with devices (e.g., the smart device **204**), including, but is not limited to:

Account data **9340** storing information related to user accounts loaded on the smart device **204**, wherein such information includes cached login credentials, smart device identifiers (e.g., MAC addresses and UUIDs), user interface settings, display preferences, authentication tokens and tags, password keys, etc.; and

Local data storage database **9342** for selectively storing raw or processed data associated with the smart device **204** (e.g., video surveillance footage captured by a camera **118**);

Bypass module **936** for detecting whether radio(s) **940** and/or radio(s) **950** are transmitting signals via respective antennas coupled to the radio(s) **940** and/or radio(s) **950** (e.g., detecting whether radio **950** is transmitting via antenna **1402-2**) and to accordingly couple radio(s) **940** and/or radio(s) **950** to their respective antennas either via a bypass line (e.g., bypass line **1408**) or an amplifier (e.g., low noise amplifier **1406-2**); and

Transmission access module **938** for granting or denying transmission access to one or more radio(s) **940** and/or radio(s) **950** (e.g., based on detected control signals and transmission requests).

Each of the above identified elements may be stored in one or more of the previously mentioned memory devices, and corresponds to a set of instructions for performing a function described above. For example, in some implementations, the one or more radios **940** and radios **950** include respective memory and firmware for storing one or more programs/executable modules of the memory **906**. The above identified modules or programs (i.e., sets of instructions) need not be implemented as separate software programs, procedures, or modules, and thus various subsets of these modules may be combined or otherwise re-arranged in various implementations. In some implementations, memory **906**, optionally, stores a subset of the modules and data structures identified above. Furthermore, memory **906**, optionally, stores additional modules and data structures not described above.

FIG. **10** is a block diagram illustrating the smart home provider server system **164** in accordance with some implementations. The smart home provider server system **164**, typically, includes one or more processing units (CPUs) **1002**, one or more network interfaces **1004** (e.g., including an I/O interface to one or more client devices and an I/O interface

to one or more electronic devices), memory **1006**, and one or more communication buses **1008** for interconnecting these components (sometimes called a chipset). Memory **1006** includes high-speed random access memory, such as DRAM, SRAM, DDR RAM, or other random access solid state memory devices; and, optionally, includes non-volatile memory, such as one or more magnetic disk storage devices, one or more optical disk storage devices, one or more flash memory devices, or one or more other non-volatile solid state storage devices. Memory **1006**, optionally, includes one or more storage devices remotely located from one or more processing units **1002**. Memory **1006**, or alternatively the non-volatile memory within memory **1006**, includes a non-transitory computer readable storage medium. In some implementations, memory **1006**, or the non-transitory computer readable storage medium of memory **1006**, stores the following programs, modules, and data structures, or a subset or superset thereof:

Operating system **1010** including procedures for handling various basic system services and for performing hardware dependent tasks;

Network communication module **1012** for connecting the smart home provider server system **164** to other systems and devices (e.g., client devices, electronic devices, and systems connected to one or more networks **162**, FIGS. **1-5**) via one or more network interfaces **1004** (wired or wireless);

Server-side module **1014**, which provides server-side functionalities for device control, data processing and data review, including but not limited to:

Data receiving module **10140** for receiving data from electronic devices (e.g., video data from a camera **118**, FIG. **1**), and preparing the received data for further processing and storage in the data storage database **10160**;

Device control module **10142** for generating and sending server-initiated control commands to modify operation modes of electronic devices (e.g., devices of a smart home environment **100**), and/or receiving (e.g., from client devices **504**) and forwarding user-initiated control commands to modify operation modes of the electronic devices;

Data processing module **10144** for processing the data provided by the electronic devices, and/or preparing and sending processed data to a device for review (e.g., client devices **504** for review by a user); and

Server database **1016**, including but not limited to:

Data storage database **10160** for storing data associated with each electronic device (e.g., each camera) of each user account, as well as data processing models, processed data results, and other relevant metadata (e.g., names of data results, location of electronic device, creation time, duration, settings of the electronic device, etc.) associated with the data, wherein (optionally) all or a portion of the data and/or processing associated with the electronic devices are stored securely; and

Account database **10162** for storing account information for user accounts, including user account information, information and settings for linked hub devices and electronic devices (e.g., hub device identifications), hub device specific secrets, relevant user and hardware characteristics (e.g., service tier, device model, storage capacity, processing capabilities, etc.), user interface settings, data review preferences, etc., where the information for associated electronic devices includes, but is not limited to, one or more device identifiers (e.g., MAC address and UUID), device specific secrets, and displayed titles.



Each of the above identified elements may be stored in one or more of the previously mentioned memory devices, and corresponds to a set of instructions for performing a function described above. The above identified modules or programs (i.e., sets of instructions) need not be implemented as separate software programs, procedures, or modules, and thus various subsets of these modules may be combined or otherwise re-arranged in various implementations. In some implementations, memory **1006**, optionally, stores a subset of the modules and data structures identified above. Furthermore, memory **1006**, optionally, stores additional modules and data structures not described above.

Furthermore, in some implementations, the functions of any of the devices and systems described herein (e.g., hub device **180**, hub server system **508**, client device **504**, smart device **204**, smart home provider server system **164**) are interchangeable with one another and may be performed by any other devices or systems, where the corresponding sub-modules of these functions may additionally and/or alternatively be located within and executed by any of the devices and systems. The devices and systems shown in and described with respect to FIGS. **6-10** are merely illustrative, and different configurations of the modules for implementing the functions described herein are possible in various implementations.

As described with respect to FIGS. **6-10**, devices in a smart home environment (e.g., smart devices **204** in FIG. **2**, such as cameras **118**, smart thermostats **102**, smart hazard detectors **104**, etc. of a smart home environment **100**, FIG. **1**) include a host of circuit components and interfaces for enabling communications with other systems, devices, and/or servers. For example, in some implementations, smart devices include a communications module (e.g., communications module **942**, FIG. **9**) which comprises one or more radios **940** and/or radios **950** for receiving and transmitting signals to other devices and across networks (sometimes referred to generally as “transceivers” or “transceiver devices”). In some implementations, the one or more radios **940** and radios **950** are components of a single integrated circuit (e.g., System on a Chip (SOC)). Given the typical physical compactness of smart devices, components of the communications module **942** and other components of the device are often collocated in close physical proximity with one another. For example, a typical smart device may contain multiple radio antennas, memory devices, sensors, chips, and other electronic components. As a consequence of their close physical spacing within smart devices, however, and in combination with components coming into close contact with conductive materials (e.g., metal casing, camera stand, wires, etc.), device components, such as antennas, are typically poorly isolated from transmissions of one another. Additionally, because these devices sometimes share the same or close frequency bands in operation (e.g., IEEE 802.11 (i.e., Wi-Fi) and 802.15.4 sharing 2.4 GHz frequency band), signals transmitted by one component tend to interfere with signals transmitted and/or received by other components. Ultimately, components of the communications module **942** typically achieve poor signal-to-noise ratio (SNR), distortion, degraded analog signal quality, and increased bit error rate (BER).

Furthermore, the poor isolation of these devices has an additional impact on the maximum input power of device components, since the transmission power of signals transmitting by one transceiver adds unexpectedly to the expected transmission of signals simultaneously received by other nearby transceivers. Sensitive device components are thus often risk of damage when their input power thresholds are exceeded. For example, referring to the front end module

**1400** of the smart device **204** in FIG. **14**, the low noise amplifier **1406-2** typically offers higher sensitivity to received signals, but consequently has a lower input power threshold than alternative amplifiers. Thus, the transmission power of antenna **1402-2**, which adds to the transmission power of any signals received by antenna **1402-1**, risks damaging components such as the low noise amplifier **1406-2**.

Various schemes and techniques are described for lessening the harmful effects arising from poorly isolated transceivers in smart devices, a strategy generally referred to as coexistence. In particular, FIGS. **11-13** illustrate various component layout strategies for achieving improved coexistence for various devices, in accordance with some implementations. Furthermore, FIG. **14** illustrates a block diagram of a communications module **942** of a smart device utilizing bypass circuitry, and FIG. **22** is a flow diagram illustrating a method of coexistence using bypass circuitry, in accordance with some implementations. Moreover, FIGS. **15A-15G** illustrate the use of control signals in a coexistence scheme, and FIGS. **23A-23F** are flow diagrams illustrating methods of using control signals in a coexistence scheme, in accordance with some implementations.

Implementations and techniques described with respect to FIGS. **11** through **15** may be combined in whole or in part to achieve improved coexistence. For example, implementations described with respect to FIGS. **15A-15G** (and corresponding methods of operation) may serve as an additional or supplementary measures for achieving optimal coexistence and operation of multiple radios in the event that implementations described with respect to FIG. **14** fail or malfunction (e.g., if the communications module **942** fails to engage the bypass line **1408**, coexistence can still be achieved through software/firmware-based implementations described in FIGS. **15A-15G**).

FIGS. **11A-11M** illustrate various assembly views of a camera device **118**, in accordance with some implementations. In particular, the embodiments illustrate the placement of the components as part of a component layout strategy for achieving improved coexistence. Components of a camera **118** (e.g., where the camera is a smart device **204**, FIG. **9**) and various implementations are described in greater detail throughout (e.g., FIGS. **9**, **14**, and **15**).

Specifically, FIGS. **11A** and **11B** illustrate perspective views of an assembled camera device **118**. The camera device **118** captures multimedia data (image, video, and audio data) in real-time, and communicates raw or processed multimedia data to its users via a remote surveillance server. The captured raw multimedia data are optionally processed locally in the camera device **118** or remotely within the remote surveillance server.

FIG. **11C** illustrates a view of the camera device **118** in which the plastic cover **1102** is removed from the camera device **118** assembly. FIGS. **11D** and **11E** further illustrate views of the camera device **118** and the locations in which one or more antennas (e.g., **1104-1** and **1104-2**) are positioned with respect to the plastic cover **1102** of the camera device **118** assembly. As shown in FIG. **11D**, a cable (e.g., RF coaxial cable) connects the antenna **1104-2** to the main circuit board of the camera device **118** (which is illustrated with greater detail in FIGS. **11H** and **11I**). Although not shown, in some implementations, the antenna **1104-1** is also connected to the main circuit board using a similar cable.

The placement of antennas **1104** within the camera device **118** assembly is such that interference from conductive and transmitting components is minimized. Placement of antennas **1104** is based at least in part on the type of antennas used. In some implementations, antennas may be integrated into or



secured by stickers or tape (or alternatively fixed using a non-conductive adhesive). By selecting the material of the enclosed housing of the camera assembly to be a less (or non) conductive material, such as plastic (e.g., plastic cover **1102**), these antennas may be fixed adhesively along the inside of the enclosing housing, thereby reducing the impact of interference otherwise experienced. Antennas **1104** may also be stamped sheet metal antennas. These antennas may be constructed as three-dimensional sheet metal antennas that are mounted on the circuit board where nearby the location of the corresponding transceiver. An example is a Planar Inverted-F Antenna (PIFA) stamped metal antenna. Alternatively, antennas **1104** may be trace antennas integrated into/onto a printed circuit board (PCB). In some implementations, the trace is laminated on the surface of the PCD. In other cases, the traces may occupy several layers of a multilayer board. Chip antennas may also be used, which are passive surface mounted antenna components often made from ceramic. Optionally, antennas **1104** may be antennas external to the enclosed housing of the camera assembly.

FIG. **11F** is an exploded view of a camera device **118** in accordance with some implementations. This view of the camera device **118** illustrates a camera lens **1108**, a plurality of LEDs **1106**, the one or more antennas **1104**.

In accordance with a regular monitor mode, the camera device **118** is configured to provide video monitoring and security in a smart home environment that is illuminated by visible light sources (e.g., the sun or light bulbs). In some implementations, the camera device **118** includes alternative operation modes, such as a night vision mode and a depth imaging mode. Each of the alternative operation modes is associated with a respective illumination condition. For example, in the night vision mode, the camera device **118** is configured to capture activities in the smart home environment at night when no or limited visible light illumination is available. In the depth imaging mode, the camera device **118** is configured to create a depth map or image for the corresponding field of view in the smart home environment. The depth map can be subsequently used in the regular monitor mode for accurate identification of objects in the smart home environment. In some implementations, the depth image is created based on one or more images captured when part of the field of view is selectively illuminated. Therefore, in some implementations, the camera device **118** is configured to include a LED illumination system, and use it as an internal light source to provide illumination in the smart home environment according to the respective illumination condition associated with each alternative operation mode of the camera device **118**.

Specifically, in some implementations, the plurality of LEDs **1106** includes infrared LEDs **1106**. The infrared LEDs **1106** are enclosed within a dark-colored, infrared-transparent plastic cover **1102** of the camera device **118**, and therefore are invisible from the exterior of the camera device **118**. Given that the plastic cover **1102** permits infrared light to pass through it, the camera device **118** can rely on the infrared LEDs **1106** to provide illumination at night. In the night vision mode, the plurality of LEDs is powered on to illuminate the field of view with infrared light at night. The camera device **118** includes infrared image sensors that capture infrared images or video clips of the field of view. In the depth imaging mode, the plurality of LEDs **1106** is grouped into a number of LED sets, and each LED set is selectively powered up to illuminate respective part of a field of view associated with a venue where the camera device **118** is located. Images captured in association with these LED sets are combined to generate a depth map of the entire field of view at the venue.

Alternatively, in some implementations, the plurality of LEDs **1106** is a mix of infrared and visible light LEDs, including at least one infrared LED and at least one visible light LED. In the night vision mode, the at least one infrared LED of the plurality of LEDs is powered on to illuminate the field of view with infrared light.

In some implementations, the plurality of LEDs **1106** is disposed on an internal assembly structure of the camera device **118**, and configured to surround the camera lens **1108** of the camera device **118**. In some implementations, as shown in the inset of FIG. **11F**, each LED is optionally tilted with an angle with respect to the optical axis that passes through a center **340** of the camera lens **1108**. Here, the optical axis is perpendicular to the lens surface at the center of the camera lens **1108**. In some implementations, each LED is tilted away from the optical axis of the camera with the angle in the range of 20-40 degrees. In this example, the plurality of LEDs **1106** includes eight LEDs that are grouped in four pairs of LEDs. The four pairs of LEDs are disposed symmetrically within four quadrants surrounding the camera lens **1108**. In some implementations, a mechanical or electrical component **314** is placed between two LED pairs or between two LEDs within a LED pair. It is noted that the camera lens **1108** can be surrounded by a number of LEDs having a different physical arrangement from the above example (e.g., the camera lens **1108** is surround by a hundred LEDs distributed uniformly in three layers surrounding the camera lens **1108**).

In some implementations, the one or more antennas **1104** are attached on an interior wall of the camera cover **1102** according to the form factor of the camera device **118**. Each of the one or more antennas **1104** is positioned at a respective preferred location with a respective preferred orientation with respect to the other antennas to suppress or reduce the impact from the presence and interference of the other antennas. In some situations, the receiving element **206** and the base assembly **208** are made from metal material, and each of the one or more antennas **1104** is positioned at a respective preferred location with a respective preferred orientation with respect to the receiving element **206** and the base assembly **208** to suppress or reduce the impact from their presence. To render the preferred location and orientation, each of the one or more antennas **1104** is marked with a respective alignment mark that is configured to guide assembly of the respective antenna onto the interior wall of the camera cover **1102**.

In some implementations, the one or more antennas include at least a first antenna and a second antenna. The first antenna is configured to wirelessly transfer data captured by the camera device **118** over a wireless local area network (WLAN), and the second antenna is configured to communicate configuration data associated with the WLAN via a first radio network for the purposes of commissioning the camera device **118** into the WLAN. In some implementations, the camera device **118** further includes a third antenna to allow the camera device **118** to communicate with a local hub device (e.g., the hub device **180** shown in FIG. **1**) via a second radio network that is distinct from the first radio network. In some implementations, the WLAN and the first and second radio networks are associated with custom or standard wireless protocols (e.g., IEEE 802.15.4, Wi-Fi, ZigBee, 6LoWPAN, Thread, Z-Wave, Bluetooth Smart, ISA100.11a, WirelessHART, MiWi, etc.). In a specific example, the first, second and third antennas are configured to transfer their respective data wirelessly according to IEEE 802.11, IEEE 802.15.4 and ZigBee specifications, respectively.

Further, in some implementations, the one or more antennas **1104** are electrically coupled to separate wireless transmitter circuits that operate on distinct frequency bands, and



transmit wireless signals at the distinct frequency bands concurrently. In some implementations, the one or more antennas **1104** are electrically coupled to a duplex filter, or a switch that controls their connections to a single wireless receiver circuit.

FIGS. **11G-11M** illustrate additional views of the camera device **118**. Particularly, FIG. **11G** illustrates exploded views of the camera device **118**. FIGS. **11H** and **11I** illustrate top and bottom views, respectively, of a main circuit board of the camera device **118**. Additionally, FIGS. **11J** and **11K** illustrate top and bottom views, respectively, of a sensor board of the camera device **118**. Moreover, FIGS. **11L** and **11M** illustrate top and bottom views, respectively, of an IR LED circuit board of the camera device **118**.

In some implementations, a camera assembly includes an enclosed housing having a rear surface, a front surface, and a periphery (e.g., camera **118**, FIGS. **11A-11M**). In some implementations, the camera assembly further includes a lens module located within the housing and configured to receive light via the front surface (e.g., lens **1108**, FIG. **11F**). In some implementations, video data captured by the lens module is exchanged between the camera assembly and a server using a wireless local area network.

In some implementations, the camera assembly further includes communication circuitry located within the housing and configured to wireless communicate over a plurality of different communication protocols (e.g., main circuit board of the camera device **118** that includes multiple transceivers). In some implementations, the communication circuitry includes a first circuit configured for communication over the first communication protocol (e.g., Wi-Fi transceiver) and a second circuit configured for communication over the second communication protocol (e.g., 802.15.4 transceiver), wherein the first circuit and the second circuit are distinct. In some implementations, the communication circuitry is an integrated circuit configured for communication over both the first and second communication protocols (e.g., radios **950**, which includes a radio **950-1** for Bluetooth LE, and a radio **950-2** for Wi-Fi, FIG. **15B**). In some implementations, the communication circuitry is configured to wireless communicate over at least three different communication protocols (e.g., Wi-Fi, 802.15.4, and Bluetooth LE). In some implementations, the second antenna is further configured for communication over a third one of the communication protocols. In some implementations, the communication circuitry is further configured to provide transmission access for communicating over the first communication protocol while denying transmission access for communicating over the second communication protocol, while detecting an activated priority control signal (e.g., using control signals as described with respect to FIGS. **15A-15G**).

In some implementations, the camera assembly further includes a first antenna arranged at a first location on an inner surface of the periphery (e.g., antenna **1104-1**), the first antenna configured for communication over a first one of the communication protocols (e.g., Wi-Fi), and a second antenna (e.g., antenna **1104-2**) arranged at a second location on the inner surface of the periphery, the second location being different than the first location, the second antenna configured for communication over a second one of the communication protocols (e.g., 802.15.4). In some implementations, the first antenna is arranged at the first location on the inner surface of the periphery and/or the second antenna is arranged at the second location on the inner surface of the periphery by an adhesive material (e.g., FIG. **11E**). In some implementations, the first antenna has a first orientation and the second antenna has a second orientation such that the impact from the presence and interference of each other antenna are suppressed

(e.g., orienting antennas **1104-1** and **1104-2** and different angles with respect to each other and other components within the camera assembly). In some implementations, the first antenna and the second antenna are marked with a respective alignment mark that is configured to guide the assembly of the respective antenna onto the interior wall of the camera lid.

In some implementations, the first antenna and the second antenna are configured to operate at the same frequency (e.g., 2.4 GHz). In some implementations, the first antenna and the second antenna are configured to operate at distinct frequencies (e.g., 2.4 GHz and 5 GHz). In some implementations, the first antenna is configured to transmit and receive, over the first communication protocol, signals comprising one or more of alerts, control signals and status information to and from other smart home devices (e.g., emergency alerts from a hazard detector **104** using 802.15.4, or any signals transmitted/received by any of the smart devices **204** described with respect to FIGS. **1-13**). Furthermore, the second antenna is configured to transmit and receive, over the second communication protocol signals for configuring the smart home device (e.g., Bluetooth LE for provisioning and setting up the camera **118**), and over the third communication protocol data corresponding to video captured by the smart home device (e.g., Wi-Fi for streaming video data).

In some implementations, the first antenna or the second antenna is configured to transmit and receive wireless signals in a wireless local area network according to the IEEE 802.11 specifications. In some implementations, wherein the first antenna or the second antenna is configured to transmit and receive wireless signals in a wireless personal area network according to the IEEE 802.15.4 standard. In some implementations, the first antenna or the second antenna is configured to transmit and receive wireless signals according to the Bluetooth Low Energy standard. In some implementations, the first antenna and the second antenna are electrically coupled to a duplex that controls their connections to a single wireless receiver circuit.

In some implementations, the camera assembly further includes a loop arm that is configured to hold the enclosed housing when the enclosed housing is inserted within a cutout opening in the loop arm. In some implementations, the loop arm is made from metal material, and the first location of the first antenna and the second location of the second antenna are such that the impact from the presence of the metal loop arm is suppressed (e.g., placed in a location that is farthest from the location at which the loop arm and the enclosed housing make contact).

FIGS. **12A-12C** illustrate various views of a smart thermostat (e.g., smart thermostat **102**, FIG. **1**) that may be used as part of a smart home environment **100**, as previously described.

Specifically, FIG. **12A** illustrates an exploded perspective view of the smart thermostat **102** with respect to its two main components, which are the head unit **1200-A** and the back plate **1200-B**. The head unit **1200-A** includes a head unit circuit board **1250** (described in further detail with respect to FIG. **12B**), and the back plate **1200-B** includes a backplate circuit board **1260** (described in further detail with respect to FIG. **12C**). Further technical and/or functional descriptions of various ones of the electrical and mechanical components illustrated hereinbelow can be found in one or more of the commonly assigned incorporated applications, such as U.S. Ser. No. 13/199,108, supra. In the drawings shown, the “z” direction is outward from the wall, the “y” direction is the head-to-toe direction relative to a walk-up user, and the “x” direction is the user’s left-to-right direction.



FIG. 12B illustrates a head-on view of the head unit circuit board **1250** for the smart thermostat, which comprises a head unit microprocessor **1202** (such as a Texas Instruments AM3703 chip) and an associated oscillator **1204**, along with DDR SDRAM memory **1206**, and mass NAND storage **1208**. For Wi-Fi capability, there is provided in a separate compartment of RF shielding **1210** a Wi-Fi module **1212**, such as a Murata Wireless Solutions LBWA19XSLZ module, which is based on the Texas Instruments WL1270 chipset supporting the 802.11 b/g/n WLAN standard. For the Wi-Fi module **1212** is supporting circuitry **1214** including an oscillator **1216**. For ZigBee capability, there is provided also in a separately shielded RF compartment a ZigBee module **1218**, which can be, for example, a C2530F256 module from Texas Instruments. For the ZigBee module **1218** there is provided supporting circuitry **1220** including an oscillator **1222** and a low-noise amplifier **1224**. Also provided is display backlight voltage conversion circuitry **1226**, piezoelectric driving circuitry **1228**, and power management circuitry **1230** (local power rails, etc.). Provided on a flex circuit **1232** that attaches to the back of the head unit circuit board by a flex circuit connector **1234** is a proximity and ambient light sensor (PROX/ALS), more particularly a Silicon Labs SII142 Proximity/Ambient Light Sensor with an I2C Interface. Also provided is battery charging-supervision-disconnect circuitry **1236**, and spring/RF antennas **1238**. Also provided is a temperature sensor **1344** (rising perpendicular to the circuit board in the +z direction containing two separate temperature sensing elements at different distances from the circuit board), and a PIR motion sensor **1242**. Notably, even though the PROX/ALS and temperature sensors **1244** and PIR motion sensor **1246** are physically located on the head unit circuit board **1940**, all these sensors are polled and controlled by the low-power backplate microcontroller on the backplate circuit board, to which they are electrically connected. Optionally, in some implementations, the head unit circuit board includes a Bluetooth module **1248**, and additional circuitry (not shown) which includes one or more oscillators, amplifiers, and/or any other support circuitry. In some implementations, the head unit circuit board includes one or more integrated circuits which include a combination of radios and transceivers. For example, in some implementations, the Wi-Fi module **1212** and the Bluetooth module **1248** comprise a single chip, wherein the Wi-Fi module **1212** and the Bluetooth module **1248** transmit and receive signals using a single antenna **1238**. Various implementations of transceivers (e.g., radios **940**, radios **950**) are described in greater detail with respect to FIGS. 9 and 14-15G.

FIG. 12C illustrates a rear view of the backplate circuit board **1260**, comprising a backplate processor/microcontroller **1262**, such as a Texas Instruments MSP430F System-on-Chip Microcontroller that includes an on-board memory **1264**. The backplate circuit board **1260** further comprises power supply circuitry **1266**, which includes power-stealing circuitry, and switch circuitry **1268** for each HVAC respective HVAC function. For each such function the switch circuitry **1268** includes an isolation transformer **1270** and a back-to-back NFET package **1272**. The use of FETs in the switching circuitry allows for “active power stealing”, i.e., taking power during the HVAC “ON” cycle, by briefly diverting power from the HVAC relay circuit to the reservoir capacitors for a very small interval, such as 100 micro-seconds. This time is small enough not to trip the HVAC relay into the “off” state but is sufficient to charge up the reservoir capacitors. The use of FETs allows for this fast switching time (100 micro-seconds), which would be difficult to achieve using relays (which stay on for tens of milliseconds). Also, such relays would

readily degrade doing this kind of fast switching, and they would also make audible noise too. In contrast, the FETS operate with essentially no audible noise. Also provided is a combined temperature/humidity sensor module **1274**, such as a Sensirion SHT21 module. The backplate microcontroller **1262** performs polling of the various sensors, sensing for mechanical wire insertion at installation, alerting the head unit regarding current vs. setpoint temperature conditions and actuating the switches accordingly, and other functions such as looking for appropriate signal on the inserted wire at installation.

In accordance with the teachings of the commonly assigned U.S. Ser. No. 13/269,501, supra, the commonly assigned U.S. Ser. No. 13/275,307, supra, and others of the commonly assigned incorporated applications, the smart thermostat **102** (FIG. 1) represents an advanced, multi-sensing, microprocessor-controlled intelligent or “learning” thermostat that provides a rich combination of processing capabilities, intuitive and visually pleasing user interfaces, network connectivity, and energy-saving capabilities (including the presently described auto-away/auto-arrival algorithms) while at the same time not requiring a so-called “C-wire” from the HVAC system or line power from a household wall plug, even though such advanced functionalities can require a greater instantaneous power draw than a “power-stealing” option (i.e., extracting smaller amounts of electrical power from one or more HVAC call relays) can safely provide. By way of example, the head unit microprocessor **1202** can draw on the order of 250 mW when awake and processing, and an LCD module (not shown) can draw on the order of 250 mW when active. Moreover, the Wi-Fi module **1212** can draw 250 mW when active, and needs to be active on a consistent basis such as at a consistent 2% duty cycle in common scenarios. However, in order to avoid falsely tripping the HVAC relays for a large number of commercially used HVAC systems, power-stealing circuitry is often limited to power providing capacities on the order of 100 mW-200 mW, which would not be enough to supply the needed power for many common scenarios.

The smart thermostat **102** resolves such issues at least by virtue of the use of a rechargeable battery (or equivalently capable onboard power storage medium) that will recharge during time intervals in which the hardware power usage is less than what power stealing can safely provide, and that will discharge to provide the needed extra electrical power during time intervals in which the hardware power usage is greater than what power stealing can safely provide. In order to operate in a battery-conscious manner that promotes reduced power usage and extended service life of the rechargeable battery, the thermostat **1800** is provided with both (i) a relatively powerful and relatively power-intensive first processor (such as a Texas Instruments AM3703 microprocessor) that is capable of quickly performing more complex functions such as driving a visually pleasing user interface display and performing various mathematical learning computations, and (ii) a relatively less powerful and less power-intensive second processor (such as a Texas Instruments MSP430 microcontroller) for performing less intensive tasks, including driving and controlling the occupancy sensors. To conserve valuable power, the first processor is maintained in a “sleep” state for extended periods of time and is “woken up” only for occasions in which its capabilities are needed, whereas the second processor is kept on more or less continuously (although preferably slowing down or disabling certain internal clocks for brief periodic intervals to conserve power) to perform its relatively low-power tasks. The first and second processors are mutually configured such that the second processor can



“wake” the first processor on the occurrence of certain events, which can be termed “wake-on” facilities. These wake-on facilities can be turned on and turned off as part of different functional and/or power-saving goals to be achieved. For example, a “wake-on-PROX” facility can be provided by which the second processor, when detecting a user’s hand approaching the thermostat dial by virtue of an active proximity sensor (PROX, such as provided by a Silicon Labs SII 142 Proximity/Ambient Light Sensor with I2C Interface), will “wake up” the first processor so that it can provide a visual display to the approaching user and be ready to respond more rapidly when their hand touches the dial. As another example, a “wake-on-PIR” facility can be provided by which the second processor will wake up the first processor when detecting motion somewhere in the general vicinity of the thermostat by virtue of a passive infrared motion sensor (PIR, such as provided by a PerkinElmer DigiPyro PYD 1998 dual element pyrodetector). Notably, wake-on-PIR is not synonymous with auto-arrival, as there would need to be N consecutive buckets of sensed PIR activity to invoke auto-arrival, whereas only a single sufficient motion event can trigger a wake-on-PIR wake-up.

FIGS. 13A-13D illustrate various views of a smart hazard detector (e.g., smart hazard detector 104, FIG. 1) that may be used as part of a smart home environment 100, as previously described.

Specifically, FIG. 13A illustrates an assembled view of the smart hazard detector 104. FIG. 13A shows the mounting plate 1324, front casing 1326, and cover plate 1328 in an assembled configuration with the various other components contained within an interior space of smart hazard detector 104. These figures also show the plurality of holes or openings of cover plate 1328 forming a visually pleasing design that is viewable by occupant of a room within which the smart hazard detector 104 is mounted. The lens button 1332 is shown attached to the smart hazard detector 104 so as to be centrally positioned with respect to cover plate 1328. As briefly described, light ring 1342 may be used to provide a halo appearance of light around and behind lens button 1332. The assembled smart hazard detector 104 provides a compact yet multifunctional device.

FIG. 13B illustrates an exploded perspective views of the smart hazard detector 104. As shown in FIG. 13B, the smart hazard detector 104 includes a mounting plate 1324 that may be attached to a wall of the building or structure to secure the smart hazard detector 104 thereto. Smart hazard detector 104 also includes a back plate 1330 that may be mounted to the mounting plate 1324 and a front casing 1326 that may be coupled with or otherwise secured to back plate 1330 to define a housing having an interior region within which components of the smart hazard detector 104 are contained. A circuit board 1300 may be coupled with or attached to back plate 1330. Various components may be mounted on circuit board 1300. For example, a smoke chamber 1334 may be coupled with or mounted on circuit board 1300 and configured to detect the presence of smoke. In one embodiment, smoke chamber 1334 may be mid-mounted relative to circuit board 1300 so that air may flow into smoke chamber 1334 from a position above circuit board 1300 and below circuit board 1300. A speaker 1336 and alarm device (not number) may also be mounted on circuit board 1300 to audibly warn an occupant of a potential fire danger when the presence of smoke is detected via smoke chamber 1334. Other components, such as a motion sensor, carbon monoxide sensor, microprocessor, and the like may likewise be mounted on circuit board 1300 as described herein.

In one embodiment, a protective plate 1338 may be attached to or otherwise coupled with circuit board 1300 to provide a visually pleasing appearance to the inner components of smart hazard detector 104 and/or to funnel or direct airflow to smoke chamber 1334. For example, when a user views the internal components of smart hazard detector 104, such as through vents in back plate 1330, protective plate 1338 may provide the appearance of a relatively smooth surface and otherwise hide the components or circuitry of circuit board 1300. Protective plate 1338 may likewise function to direct a flow of air from the vents of back plate 1330 toward smoke chamber 1334 so as to facilitate air flow into and out of smoke chamber 1334.

Smart hazard detector 104 may also include a battery pack 1340 that is configured to provide power to the various components of smart hazard detector 104 when smart hazard detector 104 is not coupled with an external power source, such as a 120 V power source of the home or structure. In some embodiments, a cover plate 1328 may be coupled with the front casing 1326 to provide a visually pleasing appearance to smart hazard detector 104 and/or for other functional purposes. In a specific embodiment, cover plate 1328 may include a plurality of holes or openings that allow one or more sensors coupled with circuit board 1300 to view or see through a surface of cover plate 1328 so as to sense objects external to smart hazard detector 104. The plurality of openings of cover plate 1328 may be arranged to provide a visually pleasing appearance when viewed by occupants of the home or structure. In one embodiment, the plurality of openings of cover plate 1328 may be arranged according to a repeating pattern, such as a Fibonacci or other sequence.

A lens button 1332 may be coupled with or otherwise mounted to cover plate 1328. Lens button 1332 may allow one or more sensors to view through the lens button 1332 for various purposes. For example, in one embodiment a passive IR sensor (not shown) may be positioned behind the lens button 1332 and configured to view through the lens button 1332 to detect the presence of an occupant or occupants within the home or structure. In some embodiments, lens button 1332 may also function as a button that is pressable by a user to input various commands to smart hazard detector 104, such as to shut off an alarm that is triggered in response to a false or otherwise harmless condition. Positioned distally behind lens button 1332 may be a light ring 1342 that is configured to receive light, such as from an LED, and disperse the light within ring 1342 to provide a desired visual appearance, such as a halo behind lens button 1332. Positioned distally behind light ring 1342 may be a flexible circuit board 1344 that includes one or more electrical components, such as a passive IR sensor (hereinafter PIR sensor), LEDs, and the like. Flexible circuit board 1344 (hereinafter flex ring 1344) may be electrically coupled with circuit board 1300 to communicate and/or receive instructions from one or more microprocessors mounted on circuit board (not shown) during operation of smart hazard detector 104.

Referring now to FIGS. 13C and 13D, illustrated are front and rear perspective views of a circuit board of a smart hazard detector (e.g., smart hazard detector 104, FIG. 1). Circuit board 1300 includes a main body 1302 having a front side or surface and a rear side or surface. As described herein, various electrical components are mounted on circuit board 1300. In some embodiments, these components may be mounted on the front surface of circuit board 1300, on the rear surface of circuit board 1300 opposite the front surface, or on both surfaces of the circuit board 1300. For example, in a specific embodiment one or more microprocessors and/or other processor related components may be mounted on the rear sur-



face of circuit board **1300** facing a protective plate while one or more functional components (e.g. an alarm device, CO detector, speaker, motion sensors, Wi-Fi device, Zigbee device, Bluetooth device, and the like) are mounted on a front surface of circuit board **1300** facing a room of the home or structure in which the smart hazard detector **104** is positioned. Other components may be mid-mounted relative to circuit board **1300** so that opposing surfaces are positioned on opposing sides of the circuit board **1300** as described herein. In some implementations, the circuit board **1300** includes one or more integrated circuits which include a combination of radios and transceivers. For example, in some implementations, a Wi-Fi device and a Bluetooth device of the smart hazard detector **104** comprise a single chip, wherein the Wi-Fi device and the Bluetooth device transmit and receive signals using a single antenna. Various implementations of transceivers (e.g., radios **940**, radios **950**) are described in greater detail with respect to FIGS. **9** and **14-15G**.

As shown in FIG. **13C**, in a specific embodiment the front surface of circuit board **1300** may include a CO detector **1304** that is configured to detect presence of carbon monoxide gas and trigger an alarm device **1306** if the carbon monoxide gas levels are determined to be too high. The alarm device **1306** (which can be a piezoelectric buzzer having an intentionally shrill or jarring sound) may likewise be mounted on the front surface of circuit board **1300** so as to face an occupant of the room in which the smart hazard detector **104** is positioned to alarm the occupant of a potential danger. Alarm device **1306** may be configured to produce one or more sounds or signals to alert the occupant of the potential danger. The front surface may further include an area **1308** in which a speaker (not shown) is positioned. The Speaker may be configured to provide audible warnings or messages to the occupant of the room. For example, the speaker may alert the occupant of a potential danger and instruct the occupant to exit the room. In some embodiments, the speaker may provide specific instructions to the occupant, such as an exit route to use when exiting the room and/or home or structure. Other messages may likewise be communicated to the occupant, such as to alert the occupant that the batteries are low, that CO levels are relatively high in the room, that the smart hazard detector **104** needs periodic cleaning, or alert the occupant of any other abnormalities or issues related to hazard detector **104** or components thereof.

Circuit board **1300** may also include one or more motion sensors mounted on the front surface thereof. The motion sensors may be used to determine the presence of an individual within a room or surrounding area of the smart hazard detector **104**. This information may be used to change the functionality of the smart hazard detector **104** and/or one or more other devices connected in a common network as described previously. For example, this information may be relayed to a smart thermostat to inform the thermostat that occupants of the home or structure are present so that the smart thermostat may condition the home or structure according to one or more learned or programmed settings. The smart hazard detector **104** may likewise use this information for one or more purposes, such as to quiet the alarm device (e.g. gesture hush) as described herein or for various other reasons.

In one embodiment, a first ultrasonic sensor **1320** and a second ultrasonic sensor **1322** may be mounted on the front surface of circuit board **1300**. The two ultrasonic sensors, **1320** and **1322**, may be offset axially so as to point in slightly different directions. In this orientation, each ultrasonic sensor may be used to detect motion of an individual based on an orientation of the smart hazard detector **104** relative to the room and/or occupant. Detecting the motion of the individual

may be used to quiet the alarm device as described herein (i.e., gesture hush) or for any other reason. In one embodiment, an axis of the first ultrasonic sensor **1320** may be oriented substantially outward relative to the smart hazard detector **104** while an axis of the second ultrasonic sensor **1322** is oriented an angle relative to the axis of the first ultrasonic sensor **1320**. The first ultrasonic sensor **1320** may sense motion of an individual when the smart hazard detector **104** is mounted on a ceiling of the home or structure. Because the first ultrasonic sensor **1320** is oriented substantially outward relative to the smart hazard detector **104**, the first ultrasonic sensor **1320** essentially looks straight down on individuals beneath the smart hazard detector **104**. The second ultrasonic sensor **1322** may similarly sense motion of the individual when the smart hazard detector **104** is mounted on a wall of the home or structure. Because the second ultrasonic sensor **1322** is oriented at an angle relative to the first ultrasonic sensor **1320** and the smart hazard detector **104**, the second ultrasonic sensor essentially looks downward toward the floor when the smart hazard detector **104** is mounted on a wall of the home or structure, rather than looking directly outward as the first ultrasonic sensor **1320**. In one embodiment, the angular offset of the two ultrasonic sensors may be approximately 30° or any other desired value.

In another embodiment, the two ultrasonic sensors, **1320** and **1322**, may be replaced by a single ultrasonic sensor that is configured to rotate within the smart hazard detector **104** so that the single ultrasonic sensor is capable of looking straight outward similar to the first ultrasonic sensor **1320** or capable of looking downward similar to the second ultrasonic sensor **1322**. The single ultrasonic sensor may be coupled to circuit board **1300** via a hinge that allows the ultrasonic sensor to rotate based on the orientation of the smart hazard detector **104**. For example, when the smart hazard detector **104** is mounted to a ceiling of the home or structure, gravity may orient the ultrasonic sensor so as to look straight downward; whereas when the smart hazard detector **104** is coupled to a wall of the home or structure, gravity may cause the ultrasonic sensor to rotate via the hinge and look downward toward a floor and relative to the smart hazard detector **104**. In another embodiment, a motor may be coupled with the single ultrasonic sensor so as to rotate the ultrasonic sensor based on the orientation of the smart hazard detector **104**. In this manner, the ultrasonic sensor may always point in a direction that is likely to detect motion of an individual within the room or space surrounding the smart hazard detector **104**. In yet another embodiment, the single ultrasonic sensor may have a wide field of view that is able to substantially accommodate both mounting positions of the two ultrasonic sensors, **1320** and **1322**.

As shown in FIGS. **13C** and **13D**, body **1310** of circuit board **1300** also includes a substantially centrally located aperture **1312** through which a smoke chamber is inserted so as to mid-mount the smoke chamber relative to the circuit board **1300**. Aperture **1312** may also include a pair of notches **1314** through which wires are inserted to electrically couple the smoke chamber with circuit board **1300**. As previously described, mid-mounting of the smoke chamber through an aperture **1312** allows smoke and air to enter the smoke chamber from both the front surface or side of circuit board **1300** and the rear surface or side of circuit board **1300**. Various aspects of the electrical components on the circuit board **1300** are now described, the positions thereon of many of which will be apparent to the skilled reader in view of the descriptions herein and FIGS. **13C** and **13D**. Included on the circuit board **1300** can be several components, including a system processor, relatively high-power wireless communications



circuitry and antenna, relatively low-power wireless communications circuitry and antenna, non-volatile memory, audio speaker, one or more interface sensors, a safety processor, safety sensors, alarm device **1306**, a power source, and powering circuitry. The components are operative to provide fail-safe safety detection features and user interface features using circuit topology and power budgeting methods that minimize power consumption. According to one preferred embodiment, a bifurcated or hybrid processor circuit topology is used for handling the various features of the smart hazard detector **104**, wherein the safety processor is a relatively small, relatively lean processor that is dedicated to core safety sensor governance and core alarming functionality as would be provided on a conventional smoke/CO alarm, and wherein the system processor is a relatively larger, relatively higher-powered processor that is dedicated to more advanced features such as cloud communications, user interface features, occupancy and other advanced environmental tracking features, and more generally any other task that would not be considered a “core” or “conventional” safety sensing and alarming task.

By way of example and not by way of limitation, the safety processor may be a Freescale KL15 microcontroller, while the system processor may be a Freescale K60 microcontroller. Preferably, the safety processor is programmed and configured such that it is capable of operating and performing its core safety-related duties regardless of the status or state of the system processor. Thus, for example, even if the system processor is not available or is otherwise incapable of performing any functions, the safety processor will continue to perform its core safety-related tasks such that the smart hazard detector **104** still meets all industry and/or government safety standards that are required for the smoke, CO, and/or other safety-related monitoring for which the smart hazard detector **104** is offered (provided, of course, that there is sufficient electrical power available for the safety processor to operate). The system processor, on the other hand, performs what might be called “optional” or “advanced” functions that are overlaid onto the functionality of the safety processor, where “optional” or “advanced” refers to tasks that are not specifically required for compliance with industry and/or governmental safety standards. Thus, although the system processor is designed to interoperate with the safety processor in a manner that can improve the overall performance, feature set, and/or functionality of the smart hazard detector **104**, its operation is not required in order for the smart hazard detector **104** to meet core safety-related industry and/or government safety standards. Being generally a larger and more capable processor than the safety processor, the system processor will generally consume more power than the safety processor when both are active.

Similarly, when both processors are inactive, the system processor will still consume more power than the safety processor. The system processor can be operative to process user interface features and monitor interface sensors (such as occupancy sensors, audio sensors, cameras, etc., which are not directly related to core safety sensing). For example, the system processor can direct wireless data traffic on both high and low power wireless communications circuitry, access non-volatile memory, communicate with the safety processor, and cause audio to be emitted from the speaker. As another example, the system processor can monitor interface sensors to determine whether any actions need to be taken (e.g., shut off a blaring alarm in response to a user detected action to hush the alarm). The safety processor can be operative to handle core safety related tasks of the smart hazard detector **104**. The safety processor can poll safety sensors

(e.g., smoke, CO) and activate alarm device **1306** when one or more of safety sensors indicate a hazard event is detected. The safety processor can operate independently of the system processor and can activate the alarm device **1306** regardless of what state the system processor is in. For example, if the system processor is performing an active function (e.g., performing a Wi-Fi update) or is shut down due to power constraints, the safety processor can still activate the alarm device **1306** when a hazard event is detected.

In some embodiments, the software running on the safety processor may be permanently fixed and may never be updated via a software or firmware update after the smart hazard detector **104** leaves the factory. Compared to the system processor, the safety processor is a less power consuming processor. Using the safety processor to monitor the safety sensors, as opposed to using the system processor to do this, can yield power savings because safety processor may be constantly monitoring the safety sensors. If the system processor were to constantly monitor the safety sensors, power savings may not be realized. In addition to the power savings realized by using safety processor for monitoring the safety sensors, bifurcating the processors can also ensure that the safety features of the smart hazard detector **104** always work, regardless of whether the higher level user interface works. The relatively high power wireless communications circuitry can be, for example, a Wi-Fi module capable of communicating according to any of the 802.11 protocols.

By way of example, the relatively high power wireless communications circuitry may be implemented using a Broadcom BCM43362 Wi-Fi module. The relatively low power wireless communications circuitry can be a low power Wireless Personal Area Network (6LoWPAN) module or a ZigBee module capable of communicating according to an IEEE 802.15.4 protocol. For example, in one embodiment, the relatively low power wireless communications circuitry may be implemented using an Ember EM357 6LoWPAN module. The non-volatile memory can be any suitable permanent memory storage such as, for example, NAND Flash, a hard disk drive, NOR, ROM, or phase change memory. In one embodiment, the non-volatile memory can store audio clips that can be played back using the speaker **1336**. The audio clips can include installation instructions or warning in one or more languages. The interface sensors can include sensors that are monitored by system processor, while the safety sensors can include sensors that are monitored by the safety processor. Sensors can be mounted to a printed circuit board, a flexible printed circuit board, a housing of a system, or a combination thereof.

The interface sensors can include, for example, an ambient light sensor (ALS) (such as can be implemented using a discrete photodiode), a passive infrared (PIR) motion sensor (such as can be implemented using an Excelitas PYQ1348 module), and one or more ultrasonic sensors (such as can be implemented using one or more Manorshi MSP1640H12TR modules). The safety sensors can include, for example, the smoke detection chamber **1334** (which can employ, for example, an Excelitas IR module), the CO detection module **1304** (which can employ, for example, a Figaro TGS5342 sensor), and a temperature and humidity sensor (which can employ, for example, a Sensirion SHT20 module). The power source can supply power to enable operation of the smart hazard detector and can include any suitable source of energy. Embodiments discussed herein can include AC line powered, battery powered, a combination of AC line powered with a battery backup, and externally supplied DC power (e.g., USB supplied power). Embodiments that use AC line power, AC line power with battery backup, or externally supplied DC



power may be subject to different power conservation constraints than battery only embodiments.

Preferably, battery-only powered embodiments are designed to manage power consumption of its finite energy supply such that smart hazard detector **104** operates for a minimum period of time of at least seven (7), eight (8), nine (9), or ten (10) years. Line powered embodiments are not as constrained. Line powered with battery backup embodiments may employ power conservation methods to prolong the life of the backup battery. In battery-only embodiments, the power source can include one or more batteries. The batteries can be constructed from different compositions (e.g., alkaline or lithium iron disulfide) and different end-user configurations (e.g., permanent, user replaceable, or non-user replaceable) can be used. In one embodiment, six cells of Li—FeS<sub>2</sub> can be arranged in two stacks of three. Such an arrangement can yield about 27000 mWh of total available power for the smart hazard detector **104**.

FIG. **14** illustrates a block diagram of a communications module **942** of a smart device utilizing bypass circuitry, in accordance with some implementations. FIG. **14** illustrates a communications module **942** of a smart device **204** (e.g., FIG. **9**), in accordance with any of the implementations disclosed in FIGS. **1-9** (e.g., devices **102**, **104**, **106**, **108**, **110**, **112**, **114**, **116**, **118**, **120**, and/or **122**, FIG. **1**, such as a camera **118**, a smart hazard detector **104**, a smart thermostat **102**, etc.).

In some implementations, the communications module **942** includes one or more radios **940**, radios **950**, a front end module **1400**, and antennas **1402**. In some implementations, the one or more radios **940** and radios **950** are communicably connected, and each have respective antennas **1402** through which respective signals are transmitted and received. As an example, the communications module **942** of a camera **118** includes a first transceiver for transmitting video data (e.g., Wi-Fi, radios **950**), and additionally includes a second transceiver for transmitting and receiving packets from other smart devices in a smart home environment (e.g., Zigbee, radios **940**). Optionally, a combined transceiver is configured for transmitting and receiving data in accordance with more than one communications protocol (e.g., radio **950** configure for Wi-Fi and Bluetooth LE). Components of the communications module **942** (e.g., radios **940**, radios **950**) are described in greater detail with regards to FIG. **9**.

The front end module **1400** of the communications module **942** includes a variety of circuit elements for manipulating (e.g., amplifying) signals received and transmitted by the radios **940**. In particular, the front end module **1400** includes switches **1404** for coupling the radios **940** and the antenna **1402** by selectively using an amplifier (e.g., amplifier **1406-1** and a low noise amplifier **1406-2**) or bypass line **1408**. Whether the front end module **1400** couples the radios **940** and the antenna **1402** by the low noise amplifier **1406-2** or the bypass line **1408** depends on whether the radio **950** is active and transmitting signals using the second antenna **1402-2**. Although not illustrated, other implementations of the front end module **1400** may include additional circuit elements, including one or more additional switches, amplifiers, transistors, and/or any combination of active or passive elements. A combination of circuit elements may be used in the front end module **1400**, for example, to modify the sensitivity of the communications module **942** and signals transmitted and/or received through the radios **940**.

As described previously, poor signal isolation typically results from the close physical placement of antennas **1402**. In particular, device components risk damage in the event that the signal power of transmitting antennas in a transmission chain nearby (e.g., antenna **1402-2** for Wi-Fi transmissions)

exceeds the maximum input power of components in the receiving chain (e.g., 802.15.4 receiving chain formed by radio(s) **940** and antenna **1402-1**).

One method for enabling and enhancing coexistence of transceiver devices (e.g., radios **940**, radios **950**) includes the use of a bypass line **1408** in a front end module **1400**. In particular, by using the switches **1404** to automatically and selectively enable the bypass line **1408** when the radio **950** (e.g., Wi-Fi) is “on” and transmitting signals through the antenna **1402-2** (e.g., radios **950** signals to the front end module **1400** through connection **1410** that it is “on” and transmitting), transmissions received through the antenna **1402-1** do not pass through the low noise amplifier **1406-2**, and instead pass through the bypass line **1408** to the radios **940**. Consequently, the effective maximum input power that can be tolerated by the front end module **1400** may be increased (i.e., the front end module **1400** has a larger input power threshold when the bypass line **1408** is used to couple the radio **940** and the antenna **1402-1**), as determined by characteristics of the bypass line **1408**, rather than the low noise amplifier **1406-2**. When the radio **950** is “off,” the switches **1404** operate to couple the radios **940** and the antenna **1402-1** with the low noise amplifier **1406-2** in the receiver pathway. Thus, with respect to receiver chain sensitivity, the front end module **1400** has a higher receiver sensitivity when the low noise amplifier **1406-2** is used to couple the radio **940** and the antenna **1402-1**. Given the selective operation of the low noise amplifier **1406-2** based on the activity of the radio **950**, the risk of damage to the low noise amplifier **1406-2** is avoided, while still achieving improved sensitivity through the use of the low noise amplifier **1406-2**. Therefore, the front end module **1400** is configured to couple the antenna **1402-1** to the radio **940** via the bypass line **1408** when the radio(s) **950** is active and transmitting signals using the antenna **1402-2** such that a signal received via the antenna **1402-1** is not amplified by the amplifier **1406-2** prior to being passed to the radio **940**. The front end module **1400** is further configured to couple the antenna **1402-1** to the radio **940** via the amplifier **1406-2** when the radio(s) **950** is not transmitting signals using the antenna **1402-2** such that a signal received via the antenna **1402-1** is amplified by the amplifier **1406-2** prior to being passed to the radio **940**. Methods of coexistence using the bypass circuitry in FIG. **14** is described in greater detail with respect to FIG. **22**.

FIGS. **15A-15G** illustrate a coexistence scheme for a smart device having multiple radios in smart home environment **100**, in accordance with some implementations.

As illustrated in FIG. **15A**, a smart device **204** (e.g., a camera **118**) transmits data to and receives data from other devices in proximity (e.g., smart hazard detector **104**, camera **118**, smart thermostat **102**). Simultaneously, data (e.g., live video stream recorded by the camera **118**) is transmitted to and from a remote server system over a network (e.g., a smart home provider server system **164**, over the network **162** through a network interface **160**). In some implementations, the various devices in the smart home environment **100** are also communicably connected and may therefore transmit/receive data from one another. The specific smart devices illustrated and described in FIG. **15A** are merely examples, and other implementations include various combinations of smart devices (not illustrated).

In some implementations, a camera **118** (or any smart device **204** that provides high bandwidth output data) needs to transmit one more video streams at different resolutions (e.g., 180p, 780p and 1080p) to the server system **164** for additional processing, storage, and/or sharing with authorized users. In some situations, as when the video stream is a live, high



definition (e.g., 780p or 1080p) video stream, this requires the camera 118 to maintain a low latency, high bandwidth connection to the server system 164 through the network interface 160 for a substantial period of time (e.g., from a few minutes to hours). This is accomplished in some implementations by the camera 118 employing a Wi-Fi connection provided by the network 162 to connect to the server system 164 to transmit video streams. At the same time, the camera 118 needs to be responsive to high priority alerts from other smart devices 204 so these alerts can be processed locally (e.g., used to change system state in the camera 118, transmitted to a hub device 180 for integration processing in view of other system alerts and status information, relayed to other smart home devices 204, or transmitted to client devices 504 that are configured to issue alerts directed to authorized users) and/or transmitted to the server system 164. In some implementations, these alerts are issued via Bluetooth or IEEE 802.11.15.4 signals by radios in other smart devices 204 (such as a smart hazard detector 304) and are received by corresponding radios in the camera 118 (or any comparable smart device 204). These alerts are typically of short duration and low bandwidth in contrast to streaming video, which is long duration and high bandwidth. In some implementations, these alerts need to be retransmitted to other smart devices 204 by the corresponding Bluetooth or IEEE 802.11.15.4 radios in the camera 118 (or any comparable smart device 204), which operate at the same frequency as the Wi-Fi radio (e.g., 2.4 GHz). This requires the camera 118 to prioritize use of the radios and antennas such that high priority transmissions received from other smart devices 204 (e.g., smoke or CO alerts) are transmitted with minimal latency, while during normal operation (e.g., when there are no incoming alerts from other smart devices 204), video streaming is enabled with high efficiency through the Wi-Fi radio. Devices with multiple radios (e.g., Wi-Fi, Bluetooth, and 802.11.15.4) may be utilized in a number of additional ways. In some embodiments, for example, one or more radios of a device may be used for secure device provisioning (e.g., via Bluetooth). Additionally, as described above, one or more radios may also be used for low-power communications (e.g., in devices not connected to a persistent power source).

Any of the operations described above in which multiple radios are utilized require a co-existence strategy, described herein, that manages the use by multiple radios (e.g., 2 or more) of one or more antennas with poor isolation from each other to transmit without interference signals at the same frequency or frequencies that would otherwise interfere.

As shown in FIG. 15A, some implementations of a communications module 942 include one or more radios 940, radios 950, antennas 1402, an optional front end module 1400 (as described in FIG. 14), and one or more control lines 1500 which transmit signals between the one or more radios 940 and radios 950 (e.g., RADIO\_PRI on control line 1500-1, RADIO\_REQ on control line 1500-2, and WIFI\_GRANT on control line 1500-3). Various components of the communications module 942 are described in greater detail with respect to FIGS. 9 and 14.

In some implementations, the control lines 1500 are used to transmit control signals between one or more radios 940 and radios 950 to manage the operation of transceiver devices in accordance with a coexistence scheme. In particular, as described in greater detail below, control signals are transmitted as a means for indicating and determining a priority of signals being transmitted by the one or more radios 940 and radios 950. A transceiver determined to have a lower priority yields to a higher priority transceiver by suspending transmissions for a duration of time as the higher priority trans-

ceiver completes transmitting/receiving data, thus lessening or altogether avoiding the negative effects of poor isolation resulting from transceiver devices operating simultaneously. As an example, when the RADIO\_PRI (i.e., request for transmission priority) and RADIO\_REQ (e.g., request for transmission) control lines 1500-1 and 1500-2 are asserted by the radios 940, the radio 950 yield to transmission requests by the radios 940 by suspending its own transmissions while the radios 940 transmit/receive data. Referring to the example in FIG. 15A, when the RADIO\_PRI and RADIO\_REQ control lines 1500-1 and 1500-2 are asserted, the radio 950 of the smart device 204 (e.g., Wi-Fi transceiver of a camera 118) momentarily suspend uploads of recorded video to the smart home provider server system 164, while permitting the radios 940 (e.g., 802.15.4) to transmit critical packets received from a smart hazard detector 104 to a smart thermostat 102 by activating (or “asserting”) the WIFI\_GRANT control signal. As a result, interference and transmission collisions are avoided between the transceiver devices, while reducing the risk of damaging hardware components (e.g., by exceeding device input power thresholds) and failing to transmit critical data (e.g., emergency pings from a smart hazard detectors 104).

In some implementations, one of the transceivers serves as a “master” device which receives requests for transmissions and moderates transmissions between itself and requesting transceivers. In the example shown, the radio 950 (e.g., Wi-Fi transceiver) is the master, as indicated by the directions of the control lines 1500 (i.e., with respect to the radio 950, WIFI\_GRANT is an output, and RADIO\_PRI and RADIO\_REQ are inputs).

The radios 940 and/or the radios 950 may operate in station mode (i.e., transceiver acts as a client that connects to an access point, such as a router), Access Point (AP) mode (i.e., transceiver acts as an access point through which other devices can connect and access other connected devices), and/or Ad-Hoc mode (e.g., mode in which network connected devices have equal status and may associate with any other network device in range). Furthermore, radios 940 and/or the radios 950 may operate in a variety of power modes (e.g., full power mode, power save mode). In the example coexistence scheme of FIGS. 15A-15G, the radio 950 (e.g., Wi-Fi) operates in station mode and full power mode. Furthermore, in the given example, the WIFI\_GRANT control signal is kept activated when the radio 950 is in power save mode.

Although the example illustrates the use of three control lines, other implementations may include additional control lines and control signals for determining a request priority of a transmitting device. Additional control lines and control signals may, for example, be used in implementations which include two or more radios 940 or radios 950 in a combined device (e.g., a combined Bluetooth and 802.15.4 chip), such that the plurality of transceiver devices can separately arbitrate with the master device.

Alternatively, in some implementations, two or more radios 940 or radios 950 are integrated as a combined device (e.g., a combined Bluetooth and Wi-Fi 802.11 chip), and a separate arbitration scheme may be implemented such that the two radios 940 or radios 950 arbitrate internally before arbitrating with the other transceiver of the communications module 942. FIG. 15B illustrates an example of an internal arbitration scheme between transceivers combined in a single device (e.g., Bluetooth and Wi-Fi transceivers combined in a single device, shown by radios 950-1 and 950-2, respectively). Using a switch 1404-3, for example, radios 950-1 and 950-2 decide between each other (e.g., based on instructions and logic in the firmware of radio 950-1 and/or 950-2) as to



which transceiver will have control over the antenna **1402-2**. Thus, the example coexistence scheme of FIG. **15A** operates independently from, but simultaneously with, any internal coexistence schemes implemented between radios **940** or radios **950** (e.g., coexistence scheme involving 802.15.4 and Wi-Fi is independent from internal coexistence scheme involving Wi-Fi and Bluetooth).

While reference is made with respect to 802.15.4 and Wi-Fi, other implementations may include any combination of other transmission protocols described with respect to FIGS. **9** and **14**.

FIG. **15C** illustrates a table of example control signal assignments. As described above, the example coexistence scheme of FIGS. **15A-15G** uses three signals, RADIO\_REQ (input), RADIO\_PRI (input) and WIFI\_GRANT (output). These control signals may be assigned to various physical pins of the radios **940** and radio **950** (e.g., pins L6, L7, and L8).

Coexistence schemes may be configured and implemented with any signal polarity (High-Active or Low-Active). In the example shown, the signal polarity is assumed to be Low-Active. In some implementations, control signals and control lines **1500** are assigned to physical pins of the transceivers, and are therefore handled by on-chip target firmware. Thus, control signals do not directly control the transceivers (e.g., to stop/resume Wi-Fi transmission), but rather operate through logic implemented by device firmware.

The use of these control signals are configured such that the radio **940** and radio **950** can support two modes of operation: a “normal” and “alarming” mode.

In the “normal” mode, the radio **940** (e.g., 802.15.4) operates asynchronously. That is, the radio **940** can request transmission access at any time. In this mode, the priority pin (e.g., RADIO\_PRI) will not be asserted. Furthermore, the radio **950** (e.g., Wi-Fi) is permitted (although not required) to complete existing packet transmissions before granting transmission requests to the radio **940** (i.e., asserting WIFI\_GRANT).

In “alarming” mode (or “high priority” mode), the radio **940** (e.g., 802.15.4) requests access in a periodic fashion. As an example, the radio **940** requests for a 900 us transmission period every 4 ms. The priority control signal (e.g., RADIO\_PRI) will be asserted during this entire period and can be used by the radio **950** (e.g., Wi-Fi) to infer the mode. In some implementations, in the alarming mode, the radio **940** and the radio **950** operate synchronously. That is, transmissions from the radio **950** (e.g., Wi-Fi) are timed with the falling (or rising) edge of the RADIO\_REQ control signal. By synchronously timing the assertion and de-assertion of the RADIO\_REQ control signal, minimum timing guarantees can be created with respect to transmission access for the radio **950**. This is in contrast to “normal mode,” where a looser coupling exists between transmissions between radio(s) **940** and radio(s) **950**, where transmission access is granted/denied in an ad hoc fashion.

Implementations of the various controls signals for supporting these modes of operation are described below.

In some implementations, the RADIO\_REQ control signal (e.g., control line **1500-2**, FIG. **15A**) is a transmission request signal from the radios **940** (e.g., 802.15.4 transceiver). When the radio **950** (e.g., Wi-Fi transceiver) detects this signal, it attempts to suspend its transmissions and simultaneously activates the WIFI\_GRANT control signal (e.g., control line **1500-3**, FIG. **15A**), indicating that its transmission has stopped and that the radios may begin transmission (e.g., on a shared 2.4 GHz frequency band).

In some implementations, the RADIO\_PRI control signal (e.g., control line **1500-1**, FIG. **15A**) is signal from the radios

**940** (e.g., 802.15.4) indicating an importance of the transmission request. Thus, if RADIO\_PRI is active when RADIO\_REQ is detected, the radio **950** (e.g., Wi-Fi) will treat it as “high priority” request. Consequently, the radio **950** attempts to shut down its transmissions as soon as possible, activates the WIFI\_GRANT control signal, and does not revoke the WIFI\_GRANT control signal until RADIO\_REQ is deactivated.

If RADIO\_PRI is inactive when RADIO\_REQ is detected, the radio **950** will treat it as “regular priority” request. Thus, if an important operation by the radio **950** is in progress (e.g., scheduled beacon receive), the WIFI\_GRANT control signal will not be activated until that operation is completed. Furthermore, if the WIFI\_GRANT control signal is already activated when the RADIO\_REQ control signal is also activated, WIFI\_GRANT will be revoked (deactivated) if and when the radio **950** seeks to access to the radio.

The RADIO\_PRI control signal is checked when the radio **950** (e.g., Wi-Fi transceiver) detects a change of the RADIO\_REQ control signal (e.g., activation/inactivation). The RADIO\_PRI control signal level must be established a time T\_PRI\_SETUP before changing the RADIO\_REQ control signal. When the RADIO\_REQ control signal is still activated when the RADIO\_PRI control signal is activated, it triggers an “alarming” mode to the radio **950**, forcing a “slotted” mode operation. The slotted mode is implemented in order to respond rapidly during a RADIO\_REQ interval in high priority mode (“alarming mode,” an example of which is described with respect to FIG. **15G**). In slotted mode, a TX Request Descriptor is placed in the hardware queue only upon inactivation of the RADIO\_REQ control signal. The transmission throughput of the radio **950** (e.g., Wi-Fi) in slotted mode is limited to a single packet in every RADIO\_REQ interval. Thus, only a single Wi-Fi packet is sent every time when the RADIO\_REQ control signal is inactivated. In some implementations, when switching from alarming mode to normal mode, the RADIO\_PRI must be inactivated when RADIO\_REQ is inactivated. Assuming 1440 Bytes/packet and a 4 ms RADIO\_REQ interval, transmission throughput of the radio **950** under alarming mode is 2.7 Mbit/sec. In addition, Wi-Fi retry limit is set to 3 in slotted mode, where default retry limit is 15.

The WIFI\_GRANT control signal is provided by the radio **950** (e.g., Wi-Fi), which, when activated, indicates that the transmission activity of the radio **950** was ceased, and that the radios **940** (e.g., 802.15.4 transceiver) may use the frequency band for transmission (e.g., 2.4 GHz band).

Furthermore, in order to achieve quick pause-resume of transmissions by a Wi-Fi transceiver, in some implementations 802.11n sub-frame aggregation is disabled. Furthermore, in some implementations, the number of TX Request Descriptors placed in the hardware transmission queue is limited to 1. As a result, the transmission throughput of the Wi-Fi transceiver, for example, is reduced about 10 Mbps even when connected to an 802.11n access point.

In some implementations, a camera device (e.g., smart device **204** in FIG. **15A**, which is a camera) includes a first and second antenna (e.g., antennas **1402-1** and **1402-2**, respectively), and a first (e.g., radio **950-1**, FIG. **15B**), second (e.g., radio **940**, FIG. **15A**), and third transceiver (e.g., radio **950-2**, FIG. **15B**). The second transceiver is coupled to the first antenna (e.g., radio **940** coupled to antenna **1402-1**), and the first and third transceivers are coupled to the second antenna (e.g., radios **950-1** and **950-2** coupled to antenna **1402-2**, FIG. **15B**). In some implementations, the first transceiver is configured to transmit and receive, over a first one of a plurality of distinct communication protocols, signals for



configuring the camera device (e.g., Bluetooth Low Energy), the second transceiver is configured to transmit and receive, over a second one of the plurality of distinct communication protocols, signals comprising one or more of alerts, control signals and status information to and from the one or more smart home devices (e.g., 802.15.4), and the third transceiver is configured to transmit and receive, over a third one of the plurality of distinct communication protocols, data corresponding to video captured by the camera device (e.g., Wi-Fi). In some implementations, the second transceiver and the first and/or third transceivers are coupled by a plurality of control lines for selectively granting or denying transmission access to the first, second, and third transceivers (e.g., control lines 1500, FIG. 15A). In some implementations, the first transceiver and the third transceiver comprise a single combined transceiver (e.g., radio 950, which includes radio 950-1 and radio 950-2, FIG. 15B), and the second transceiver is coupled to the single combined transceiver by the plurality of control lines (e.g., radio 940 and radio 950 coupled by control lines 1500, FIG. 15A).

In some implementations, the plurality of control lines include a first control line for a priority control signal (e.g., RADIO\_PRI on control line 1500-1, FIG. 15A), a second control line for a radio request control signal (e.g., RADIO\_REQ on control line 1500-2), and a third control line for granting or denying transmission access to the second transceiver or the third transceiver (e.g., WIFI\_GRANT on control line 1500-3). Transmission access is granted or denied to the second transceiver or the third transceiver using the third control line in accordance with detection of an activated or deactivated priority control signal, an activated or deactivated radio request control signal, and/or a transmission request by the third transceiver. In some implementations, transmission access is granted to the second transceiver and denied to the third transceiver if an activated priority control signal is detected on the first control line and an activated radio request control signal is detected on the second control line; or a deactivated priority control signal is detected on the first control line and the activated radio request control signal is detected on the second control line, but the transmission request by the third transceiver is not detected. In some implementations, transmission access is denied to the second transceiver and granted to the third transceiver if an activated priority control signal is detected on the first control line, a transmission request by the third transceiver is detected, and a deactivated radio request control signal is detected on the second control line; or a deactivated priority control signal is detected on the first control line and the transmission request by the third transceiver is detected. Granting and denying of transmission access to the first transceiver, the second transceiver, and/or the third transceiver is described in greater detail with respect to FIGS. 23A-23F.

FIGS. 15D-15G illustrate various signal timing diagrams and timing charts for various modes of operation in a coexistence scheme, in accordance with some implementations. As stated previously, in the examples shown and described with respect to FIG. 15D-15G, the signal polarity of the control signals is Low-Active (i.e., control signal is considered “active” when low), although control signals may be configured in other implementations to have a High-Active polarity. Furthermore, the timing charts illustrated in FIGS. 15D-15G are merely examples of timing requirements (e.g., minimum/maximum requirements) for an example coexistence scheme, and in other implementations, the communications module 942 of a smart device (e.g., camera 118, smart hazard detector 104, smart thermostat 102, etc.), and compo-

nents thereof (e.g., radios 940, radios 950), are configured to satisfy other predefined timing requirements.

In particular, FIGS. 15D-1 and 15D-2 illustrate a signal timing diagram and timing chart for a normal mode of operation for a coexistence scheme, in accordance with some implementations.

As shown in FIG. 15D-1, even if the RADIO\_PRI control signal is activated, the WIFI\_GRANT control signal is not asserted until the RADIO\_REQ control signal is activated. As shown in the timing chart of FIG. 15D-2, T\_PRI\_SETUP is the setup time between asserting RADIO\_PRI and asserting RADIO\_REQ. Moreover, T\_REQ\_LATENCY is the latency between asserting RADIO\_REQ and asserting WIFI\_GRANT. The T\_REQ\_LATENCY time is defined by requirements of the radios 940 (e.g., 802.15.4 radio requirement) and implementation limitations of the radio 950 (e.g., Wi-Fi). In some implementations, the T\_REQ\_LATENCY time is mainly general-purpose I/O (GPIO) interrupt latency plus the TX DMA stop latency (e.g., a maximum of 3.5 msec). The WIFI\_GRANT control signal could be further delayed, however, for beacon protection (described in greater detail with respect to FIGS. 15F-1 and 15F-2).

Furthermore, as shown in FIG. 15D-1, when both the RADIO\_PRI control signal and the RADIO\_REQ are deactivated, the WIFI\_GRANT is revoked. The T\_REVOKE\_LATENCY time is the latency between de-asserting RADIO\_REQ and de-asserting WIFI\_GRANT.

Additional timing metrics include T\_REQ\_PERIOD, which is the length of time for which the RADIO\_REQ control signal is asserted. In some implementations, T\_REQ\_PERIOD is defined from requirements of the radios 940 (e.g., 802.15.4 radio requirement) and throughput/connection stability of the radio 950 (e.g., Wi-Fi). Furthermore, T\_REQ\_INTERVAL is defined as the interval of time between asserting the RADIO\_REQ control signal.

FIGS. 15E-1 and 15E-2 illustrate a signal timing diagram and timing chart for a mode of operation in a coexistence scheme in which a request grant is revoked based on predefined performance requirements, in accordance with some implementations.

In particular, the signal timing diagram of FIG. 15E-1 illustrates a signal timing diagram in which the WIFI\_GRANT control signal is revoked in accordance with Quality of Service (QoS) requirements. In the example provided, when RADIO\_PRI is not asserted, WIFI\_GRANT will be revoked when there is a high priority transmission request by the radio 950 (e.g., Wi-Fi), even if the RADIO\_REQ control line is still asserted. In some implementations, a “High priority” transmission request is considered to be within an Access Category (AC) that is above BE (Best Effort), VI (Video) and/or VO (Voice), respectively. For example, management frames are considered to be the same priority as VO (Voice).

FIG. 15E-2 illustrates a timing chart in which WIFI\_GRANT is revoked in accordance with QoS requirements. As the RADIO\_PRI control signal is assumed to be de-asserted, this example pertains only to a non-priority coexistence request.

As shown in FIG. 15E-1, if a “high priority” transmission occurs, WIFI\_GRANT will be revoked even if the RADIO\_REQ control signal is asserted. The time T\_REVOKE\_LEAD\_Q is defined as the lead period between de-asserting the WIFI\_GRANT and the “high priority” Wi-Fi transmission. Furthermore, the time T\_WIFI\_ACT is the duration of time of the high priority Wi-Fi transmission.



When the high-priority transmission ceases, WIFI\_GRANT is re-asserted, the amount of time between such occurrences being defined by T\_REGRANT\_LATENCY\_Q.

Other timing metrics include T\_GRANT\_MIN\_Q, which is the minimum amount of time for which WIFI\_GRANT can be guaranteed to be asserted. In some implementations, because transmission activity of the radio 950 (e.g., Wi-Fi) is asynchronous to a request signal from the radios 940 (e.g., 802.15.4), a minimum WIFI\_GRANT period (e.g., time T\_GRANT\_MIN\_Q) is not guaranteed.

Furthermore, T\_WIFI\_IDLE is defined as the interval of time between high-priority transmission requests.

FIGS. 15F-1 and 15F-2 illustrate a signal timing diagram and timing chart for a mode of operation for a coexistence scheme utilizing beacon protection, in accordance with some implementations.

FIG. 15F-1 illustrates a timing chart with beacon protection. When RADIO\_PRI is not asserted, WIFI\_GRANT will be revoked in order to avoid interference with incoming beacons received by the radio 950 (e.g., Wi-Fi beacons). As the RADIO\_PRI control signal is assumed to be de-asserted, this example pertains only to a non-priority coexistence request.

As shown, if a beacon transmission occurs, WIFI\_GRANT will be revoked even if the RADIO\_REQ control signal is asserted.

T\_GRANT\_MIN is defined as a minimum period of time for which WIFI\_GRANT can be guaranteed to be asserted before being revoked by a beacon transmission. T\_REVOKE\_LEAD is defined as a lead period between WIFI\_GRANT being de-asserted and the time at which a beacon is scheduled to be received at the radio 950. T\_GRANT\_MIN and T\_REVOKE\_LEAD are defined from requirements of the radios 940 (e.g., 802.15.4 radio requirement). Furthermore, in some implementations, the radio 950 (e.g., Wi-Fi transceiver) can be programmed to have timer control up to a precision of 1 ms.

T\_BEACON\_ACT is the period of time a beacon is received by the radio 950 (e.g., a Wi-Fi beacon) and is defined as how long a beacon signal can be. WIFI\_GRANT would not be re-asserted by timeout while the radio 950 is still receiving a beacon. As an example, for a 2.4 GHz beacon sent at a 1 Mbps DSSS rate, given a typical beacon frame of approximately 300 Bytes, T\_BEACON\_ACT is defined to be approximately  $300 \times 8 \times 1$  us, or 2.4 ms.

T\_BEACON\_INT is defined as an interval of time for the beacon. In some implementations, T\_BEACON\_INT is defined as T\_GRANT\_MIN+T\_REVOKE\_LEAD. In some implementations, the beacon interval T\_BEACON\_INT is defined by the Access Point to which the radio 950 is connected. As an example, the default beacon interval of an Access Point is 100 TUs (or 102.4 ms).

FIG. 15F-3 illustrates an example of a signal timing diagram with beacon skipping. When RADIO\_REQ is asserted without RADIO\_PRI at a time that is too close to receiving the next scheduled beacon, WIFI\_GRANT is asserted only after the scheduled beacon has been received and completed. In this case, T\_REQ\_LATENCY (i.e., time between asserting RADIO\_REQ and WIFI\_GRANT being asserted consecutively) may be defined as (T\_GRANT\_MIN+T\_REVOKE\_LEAD+T\_BEACON\_ACT).

FIGS. 15G-1 and 15G-2 illustrate a signal timing diagram and timing chart for an “alarming” mode of operation for a coexistence scheme, in accordance with some implementations.

As shown in FIG. 15G-1, RADIO\_PRI is kept activated while in alarming mode, and is de-activated at the termination

of the last transmission request (e.g., RADIO\_REQ). The alarming mode may include situations in which critical data is being transmitted and received by the radio 940 (e.g., pings from hazard detection devices being received and transmitted to other devices). In these situations, the coexistence must be configured to support the receipt and transmission of this data, while synchronously transmitting data through the radio 950 (e.g., transmitting data packets of a recorded video stream through Wi-Fi) during intervals of time when the radio 940 is not requesting transmission access (e.g., between transmissions of the radio 940).

As shown, during an alarming mode, RADIO\_PRI is first asserted, and RADIO\_REQ is asserted at a time T\_PRI\_SETUP afterwards. Once RADIO\_REQ has been asserted, the radio 950 grants transmission access by asserting WIFI\_GRANT at a time T\_REQ\_LATENCY\_A afterwards. When the RADIO\_REQ transmission request from the radio 940 finishes, WIFI\_GRANT is revoked at time T\_REVOKE\_LATENCY\_A afterwards. The interval T\_REQ\_INTERVAL\_A is an interval of time between transmission requests from the radio 940 (e.g., RADIO\_REQ). During this time, WIFI\_GRANT is revoked, and therefore transmission access is set aside for the radio 950 (e.g., data packets for a video stream over Wi-Fi).

In some implementations, during an alarming mode, after asserting RADIO\_REQ, the radio 940 begins transmission at a time T\_REQ\_LATENCY\_A afterwards regardless of whether the WIFI\_GRANT is asserted.

FIG. 16 shows an illustrative co-existence circuit 1700 for managing operations of three communications circuits, in accordance with some implementations. In the example shown, circuitry 1700 includes 6LOWPAN circuitry 1710 (e.g., a first radio 940, FIG. 9), BLE circuitry 1720 (e.g., a second radio 940), Wi-Fi circuitry 1730 (e.g., a first radio 950), and OR gates 1740 and 1742. Request for Access (RFA) line 1711 may be connected to BLE circuitry 1720 and an input of OR gate 1740. An RFA line may be asserted by a communication circuit when it requires access to an RF medium. An RF medium can include an antenna and/or a communications frequency. RFA line 1721 may be connected to 6LOWPAN circuitry 1710 and an input of OR gate 1740. The output of OR gate 1740 may be connected to Wi-Fi circuitry 1730. Priority Line 1712 may be connected to an input of OR gate 1742, and priority line 1722 may be connected to an input of OR gate 1742. A priority line may be asserted by a communication circuit that is requesting high priority access to the RF medium. The output of OR gate 1742 may be connected to Wi-Fi circuitry 1730. Grant line 1731 may be connected to 6LOWPAN circuitry 1710 and BLE circuitry 1720. Grant signals may be provided on grant line 1731 to indicate which communications circuit is granted access to the RF medium. Grant signals may be provided by a master circuit, which is illustrated as Wi-Fi circuitry 1730. Each of circuitries 1710, 1720, and 1730 may require access to the same RF medium when communicating data.

Although the examples provided in FIGS. 16-21 are described with respect to a multi-transceiver device that includes circuitry for 6LOWPAN, BLE, and Wi-Fi transmission protocols specifically, in other implementations, the circuitry 1700 may include any combination of three or more radios 940 and/or radios 950. In such implementations, the methods described in FIGS. 16-21 with respect to priority lines and how respective circuitry operates will apply analogously. In other words, the coexistence schemes and methods described in FIGS. 16-21 are generally applicable to any multi-radio device (e.g., smart devices having three or more radios).



## 51

The RFA lines 1711 and 1721 may be shared among both 6LOWPAN circuitry 1710 and BLE circuitry 1720 so that the circuits are aware of when each makes a request for access. Such information sharing can assist in avoiding collision events. The RFA may be provided to Wi-Fi circuitry 1730, which decides whether to grant access. The priority lines may specify that a particular circuit is given priority over the other circuit and that its request to access the RF medium is of high priority and the other communication circuits should yield where possible. For example, 6LOWPAN circuitry 1710 may have priority over BLE circuitry 1720 during an alarm event. In the event of potential collisions for RF medium access, master or host circuitry can control which circuitry is granted access. The master or host circuitry can be a processor other than one of the communications circuits (e.g., system processor 402) or it can be implemented by an onboard processor of one of the communication circuits (e.g., Wi-Fi circuitry 1730).

Priority may be conveyed using one of two different approaches. One approach uses direct notification. In this approach, the host (e.g., Wi-Fi 1730) can issue grant command to the communications circuits to inform them which has priority. The grant command may not necessarily be a single Boolean value, but can include an enumeration or bit field indicating which circuit has priority or is allowed to assert its priority line. In another approach, implicit notification may be used. In implicit notification, a circuit may impliedly have priority if its priority input pin is not asserted. If its priority input pin is asserted, then it may not have priority.

The 6LoWPAN communication circuitry priority cases are shown and described in Table 1.

TABLE 1

No Priority, Yield to BLE Circuitry	6LO_Priority not asserted, yield to BLE when Grant asserted but BLE_RFA also asserted
Priority	6LO_Priority asserted, do not yield BLE_RFA asserted
No Priority, Retain access against BLE Circuitry	6LO_Priority not asserted, do not yield to BLE when Grant asserted but BLE_RFA also asserted

The BLE communications circuitry priority cases are shown and described in Table 2.

TABLE 2

No Priority	BLE_Priority not asserted, yield to 6LoWPAN when Grant asserted but 6LO_RFA also asserted
Priority	BLE_Priority asserted, do not yield to 6LO_RFA asserted

The priority cases for Wi-Fi circuitry 1730 are described in connection with FIGS. 17A-17B. FIG. 17A shows an illustrative base case in which both priority lines for 6LOWPAN circuitry 1710 and BLE circuitry 1720 are LOW, indicating that these circuits are not requesting priority. In addition, there are no pulses in 6LO\_RFA nor BLE\_RFA, indicating that 6LoWPAN 1710 and BLE circuitry 1720 are not requesting access. From time t0 to t1, the Grant line is HIGH, implying that Wi-Fi circuitry 1730 is granting access to the RF medium. From time, t1 to time, t2, Grant is LOW and Wi-Fi Tx is HIGH. Thus, Wi-Fi circuitry 1730 denies grant when it wishes to transmit. This is also shown between time, t3 and t4. Moreover, during the base case, 6LoWPAN circuitry 1710

## 52

and BLE circuitry 1720 may be permitted to access the RF medium when Grant is HIGH.

FIG. 17B shows an illustrative case showing grant and denial of 6LoWPAN circuitry 1710 access to the RF medium based status of Grant, in accordance with some implementations. As shown, between times t1 and t2, 6LO\_RFA is HIGH while Grant is HIGH, thereby enabling 6Lo Tx to go HIGH. Starting at time, t3, 6Lo Tx is initially HIGH, but this transmission is denied at time, t4, when Grant is set LOW and Wi-Fi Tx goes HIGH. Then, at time t5, Grant returns to HIGH, thereby enabling 6LoWPAN circuitry to continue transmitting.

FIGS. 18A-D shows different illustrative 6LoWPAN priority use case, in accordance with some implementations. In particular, FIG. 18A shows an illustrative base case and FIGS. 18B-18D show priority, no priority, and Retain access against BLE priority use cases, respectively, of Table 1. As shown in the base case of FIG. 18A, 6LoWPAN circuitry 1710 requests access twice and is granted access both times. In addition, there are no collisions and 6LO\_Priority and Grant are HIGH throughout.

FIG. 18B shows an illustrative priority use case for 6LoWPAN in which 6LO\_Priority is HIGH throughout. From times t1-t2, there are not request for access by either 6LO or BLE, thereby enabling Wi-Fi to revoke its Grant and transmit. At time t3, 6LO\_RFA goes HIGH and 6LO Tx transmits from time t3 to t4. At time t5, Wi-Fi Tx goes HIGH. However, at time t6, 6LO\_RFA goes HIGH, and because 6LO has priority, Wi-Fi Tx goes LOW and 6LO is permitted to transmit.

Referring now to FIG. 18C, 6LO\_Priority and Grant are HIGH throughout. At times t1-t2, BLE\_RFA is HIGH, and because 6LO\_RFA is LOW, there is no conflict, and BLE Tx is permitted to go HIGH. At times t3-t4, 6LO\_RFA is HIGH, and is granted access, resulting in 6LO Tx going HIGH. Starting at time t5, BLE\_RFA is HIGH, and BLE Tx begins to transmit until time, t6, at which point 6LO\_RFA goes HIGH. Now, at time t6, there is a conflict between 6LO\_RFA and BLE\_RFA, but because 6LO\_Priority is HIGH, 6LO Tx goes HIGH, indicating that 6LoWPAN circuitry 1710 decides to transmit despite the assertion by BLE circuitry 1720.

Referring now to FIG. 18D, both 6LO\_Priority and BLE\_Priority are LOW but circuitry 1700 is configured to permit grant 6LoWPAN circuitry 1710 access in case of a collision. Starting at time t1, 6LO\_RFA goes HIGH and at time t2, BLE\_RFA goes HIGH, but Grant goes LOW to allow Wi-Fi circuitry to transmit until time t3. At time t3, Grant goes HIGH, at which time, 6LO Tx begins transmitting (as shown). BLE\_Tx does not transmit because BLE circuitry 1720 does not have priority and knows that 6LO\_RFA has already been asserted. BLE\_Tx may go HIGH as it detects the falling edge of 6LO\_Tx at time t4.

The priority use cases for BLE circuitry 1720 are similar to the priority use cases of 6LoWPAN circuitry 1710. For example, if FIGS. 18A-18C were used to illustrate the priority use cases of BLE circuitry 1720, the 6LO priority, RFA, and Tx labels can be transposed with the BLE priority, RFA, and Tx labels.

FIGS. 19A and 19B show illustrative timing diagrams where Wi-Fi circuitry 1730 is OFF, in accordance with some implementations. When Wi-Fi circuitry 1730 is OFF, 6LoWPAN circuitry 1710 and BLE circuitry 1720 are operative to arbitrate among themselves to determine who has access to the RF medium. 6LoWPAN circuitry 1710 and BLE circuitry 1720 may arbitrate among themselves based on their priority line assertions and the state of the other circuit's RFA signal. FIG. 19A illustrates timing diagrams where Wi-Fi is OFF and 6LoWPAN circuitry has priority, in accordance with some



implementations. As shown, 6LO\_Priority and Grant are HIGH. At time t1, 6LO\_RFA goes HIGH and then goes LOW at time t2. 6LO Tx is HIGH from times t1 to t2. At time t3, 6LO\_RFA goes HIGH, during which time, 6LO Tx is also HIGH. BLE\_RFA goes HIGH at time t4 and remains HIGH. BLE\_Tx continues to yield to 6LO Tx until time t5, at which point 6LO\_RFA goes LOW. 6LO Tx may not yield between times t4 and t5, despite the pulse on BLE\_RFA, because 6LoWPAN circuitry 1710 has priority.

FIG. 19B illustrates timing diagrams where Wi-Fi is OFF and BLE circuitry has priority, in accordance with some implementations. As shown, Grant and BLE\_Priority are HIGH. At times t1 to t2, 6LO Tx is permitted access to transmit since there is no collision. At time t3, 6LO\_RFA goes HIGH, and 6LO Tx begins transmitting. At time t4, however, BLE\_RFA goes HIGH. Since BLE circuitry has priority, BLE\_Tx takes priority over 6LO\_Tx. As a result, BLE\_Tx goes HIGH and 6LO Tx goes LOW.

Referring now to FIG. 20, an illustrative timing diagram showing how the BLE circuitry attempts to communicate with a personal device during the idle portion of a wake packet being transmitted by 6LoWPAN circuitry during a NCCA period, in accordance with some implementations. During the NCCA period, Wi-Fi circuitry 1730 is not yet turned ON, therefore 6LoWPAN circuitry 1710 and BLE circuitry 1720 may arbitrate amongst themselves to determine who has access to the RF medium. For purposes of this timing diagram, assume that the 6LoWPAN has priority (e.g., because hazard detection system has raised its alarm). FIG. 20 shows that the NCCA wake packet transmission cycle has a period including an active portion (as evidenced by the HIGH pulse) and an idle portion (as evidenced by the LOW signal). The 6LoWPAN RFA may track the active portion of each wake packet. Since 6LoWPAN circuitry 1710 has priority, it controls access to the RF medium regardless of any RFA by BLE circuitry 620. This is shown in the FIG., as evidenced by 6LoWPAN Tx going HIGH in concert with the 6LoWPAN pulses. BLE\_RFA is shown to remain HIGH throughout the timing diagram, thus indicating BLE circuitry 1720's desire to attempt communications with a personal device (not shown). BLE circuitry 1720 is permitted to communicate during the idle portion of each wake packet transmission. This is shown where BLE Tx goes HIGH when 6LoWPAN Tx goes LOW, and vice versa.

During the BLE Tx HIGH signal period, BLE circuitry 1720 attempts to communicate with one or more personal devices. BLE circuitry 1720 may do this by 1) advertising its presence to the personal device (e.g., on channel 37 of a BLE protocol), 2) authenticating the personal device (e.g., on channel 38 of the BLE protocol), and 3) commencing data transfer with the personal device (e.g., on channel 39 of the BLE protocol). BLE circuitry 1720 may perform all three steps during a single BLE Tx session or over a series of BLE Tx sessions. The data transfer can specify instructions for altering the state of the system. For example, if the system is alarming, the instruction can contain a hush instruction that commands the system to change from an alarming state to a hush state.

FIG. 21 shows illustrative timing diagrams of exemplary BLE advertise, connect, and data transfer activity during BLE transmissions, in accordance with some implementations. The BLE operations of advertise, connect, and data transfer may occur during BLE\_Tx activity, which occur when BLE\_Tx is HIGH. As shown in FIG. 21, the BLE operations are performed in one of the four BLE\_Tx activity windows. BLE Advertise may occur during BLE\_Tx activity window 1, and BLE connect may occur during BLE\_Tx activity window

2. After a connection is made, BLE data may be transmitted between a personal device and the system during windows 3 and 4.

FIG. 22 is a flow diagram illustrating a method of coexistence using bypass circuitry, in accordance with some implementations. In some implementations, the method 2200 is performed at an electronic device (e.g., devices of a smart home environment 100, FIGS. 1 and 12; smart devices 204 and/or hub device 180 of smart home network 202, FIG. 2) having a plurality of transceivers and antennas (e.g., smart device 204, FIG. 14, having one or more radios 940 and/or radios 950, and antennas 1402). More specifically, in some implementations, the method 2200 is performed by one or more components of the electronic device (e.g., communications module 942 of smart device 204, or a front end module 1400 of the communications module). For ease of reference, the methods herein will be described as being performed by an electronic device (e.g., smart device 204). FIG. 22 corresponds to instructions stored in a computer memory or other computer-readable storage medium (e.g., memory 606 of the hub device 180), or instructions stored in the memory of one or more components of the electronic device (e.g., memory of the communications module 942, not illustrated).

The electronic device (e.g., smart device 204, which is a camera) includes a plurality of transceivers (e.g., radio(s) 940 and radio(s) 950, FIG. 14), one or more processors, and memory storing instructions for execution by the one or more processors. The electronic device detects (2204) whether a second transceiver (e.g., radio 950) of the plurality of transceivers is not transmitting signals via a second antenna (e.g., antenna 1402-2) coupled to the second transceiver. In some implementations, a bypass signal is produced (2202) when the second transceiver is active, where detecting (2204) whether the second transceiver is transmitting signals includes (2206) detect the bypass signal. For example, a bypass signal is produced and detected on connection 1410 (FIG. 14) when radio 950 is transmitting.

In accordance with detecting that the second transceiver is not transmitting signals via the second antenna, a first transceiver (e.g., radio 940) of the plurality of transceivers is coupled (2208) to a first antenna via an amplifier such that a signal received by the first antenna is amplified by the amplifier prior to being passed to the first transceiver. In some implementations, the amplifier is a low-noise amplifier (e.g., low noise amplifier 1406-2, FIG. 14).

In accordance with detecting that the second transceiver is transmitting signals via the second antenna, the first transceiver is coupled (2210) to the first antenna via a bypass line (e.g., bypass line 1408) such that a signal received by the first antenna is not amplified by the amplifier prior to being passed to the first transceiver.

In some implementations, the first and second antennas receive and transmit signals at the same frequency (e.g., 2.4 GHz).

FIGS. 23A-23F are flow diagrams illustrating methods of using control signals in a coexistence scheme, in accordance with some implementations. In some implementations, the methods 2300 and 2330 are performed at an electronic device having a plurality of transceivers and antennas (e.g., smart device 204 of FIGS. 9 and 15A-15B, having one or more radios 940 and/or radios 950). More specifically, in some implementations, the methods 2300 and 2330 are performed by one or more components of the camera device (e.g., communications module 942 of smart device 204). For ease of reference, the methods herein will be described as being performed at a camera device (e.g., smart device 204 of FIG. 15A, a camera). FIGS. 23A-23F correspond to instructions



stored in a computer memory or other computer-readable storage medium (e.g., memory **606** of the hub device **180**), or instructions stored in the memory of one or more components of the electronic device (e.g., memory of the communications module **942**, not illustrated).

The camera device includes a plurality of distinct transceivers configured for communication over respective communication protocols (e.g., radio **940** and radios **950**, which includes radios **950-1** and **950-2**, FIGS. **15A-15B**), one or more processors, and memory storing instructions for execution by the one or more processors.

In performing the method **2300**, the camera device communicates (**2302**) using a first transceiver of the plurality of distinct transceivers, the first transceiver configured to transmit and receive, over a first one of the communication protocols, signals for configuring the camera device (e.g., radio **950-1** of radios **950**, FIGS. **15A-15B**). In some implementations, the first communication protocol is (**2304**) based on the Bluetooth Low Energy standard. In some implementations, communicating (**2302**) using the first transceiver includes transmitting (**2306**) data comprising a video format configured for low-bandwidth transmissions (e.g., a low resolution encoded video stream).

The camera device communicates (**2308**) with one or more smart home devices using a second transceiver of the plurality of transceivers. The second transceiver (e.g., radio **940**, FIG. **15A**) is configured to transmit and receive, over a second one of the communication protocols, signals comprising one or more of alerts, control signals and status information to and from the one or more smart home devices (e.g., emergency alerts from hazard detectors **104**, FIG. **1**). In some implementations, the second communication protocol is based (**2310**) on the IEEE 802.15.4 standard. In some implementations, communicating (**2308**) using the second transceiver includes (**2312**) transmitting data comprising the video format configured for low-bandwidth transmissions (e.g., a low resolution encoded video stream). In some implementations, communicating (**2308**) using the second transceiver includes (**2314**) receiving intermittent signals from the one or more smart home devices and/or retransmitting received signals from the one or more smart home devices, concurrently with the transmission of data using a third transceiver (e.g., receiving emergency pings from connected smart hazard detectors **104** using radio **940** (FIG. **15A**) while transmitting video data over Wi-Fi radio **950-2** (FIGS. **15A-15B**)). In some implementations, the transmission of data using the third transceiver is temporarily suspended (**2316**) while receiving signals from the one or more smart home devices and/or retransmitting received signals from the one or more smart home devices. For example, radio **940** and radios **950** coordinate transmission access such that the radio **940** and radios **950** are not both simultaneously transmitting signals at a given time (e.g., communications module **942** moderates transmission access by the radio **940** and radios **950**, and selectively grants/denies transmission access to the radio **940** and radios **950**).

Referring now to FIG. **23B**, the camera device communicates (**2318**) using the third transceiver of the plurality of transceivers. The third transceiver (e.g., radio **950-2** of radios **950**, FIGS. **15A-15B**) is configured to transmit and receive, over a third one of the communication protocols, data corresponding to video captured by the camera device. In some implementations, the third communication protocol is based (**2320**) on the IEEE 802.11 standard. In some implementations, the data comprises (**2322**) a video format configured for high-bandwidth transmissions (e.g., high resolution video streaming of video surveillance footage using Wi-Fi). In some implementations, communicating (**2318**) using the

third transceiver includes (**2324**) receiving and transmitting data at a data rate that is higher than a data rate at which the camera device communicates using the first transceiver and/or a data rate at which the camera device communicates using the second transceiver (e.g., streaming high-resolution video using Wi-Fi radio **950-2**, while streaming low-resolution video using 802.15.4 radio **940**, FIGS. **15A-15B**).

In some implementations, the camera device receives (**2326**) signals from the one or more smart home devices over the second communication protocol, and retransmits (**2328**) the signals to one or more other smart home devices (e.g., receiving and retransmitting emergency pings from connected smart hazard detectors **104** using radio **940**, FIG. **15A**).

Referring now to FIG. **23C**, the camera device may perform the method **2330** additionally to and/or in conjunction with the method **2300**. In performing the method **2330**, in some implementations, the camera device grant or deny transmission access to the first transceiver (e.g., radio **950-1** of radios **950**, FIGS. **15A-15B**, such as Bluetooth LE), the second transceiver (e.g., radio **940**, FIG. **15A**, such as 802.15.4), and/or the third transceiver (e.g., radio **950-2** of radios **950**, FIGS. **15A-15B**, such as Wi-Fi) of the plurality of distinct transceivers of the camera device, where the transceivers are configured for communication over respective communication protocols.

In some implementations, granting or denying transmission access (**2332**) includes (**2334**) detecting activation of a priority control signal (e.g., assertion of RADIO\_PRI signal on control line **1500-1**, FIG. **15A**). In some implementations, the activated priority control signal corresponds (**2336**) to an alarming mode of the second transceiver (e.g., incoming emergency alerts from a hazard detector **104**). In response to detecting activation of the priority control signal, transmission access is granted (e.g., by the “master” transceiver, such as radio(s) **950**, FIG. **15A**) to the second transceiver (e.g., e.g., 802.15.4 radio **940**) and transmission access is denied to the third transceiver (e.g., Wi-Fi radio **950-2**).

In some implementations, an activated priority control signal is detected (**2304**) (e.g., an already asserted RADIO\_PRI signal on control line **1500-1** is detected). While detecting the activated priority control signal (**2342**), activation of a radio request control signal by the second transceiver is detected (**2344**) (e.g., assertion of RADIO\_REQ signal on control line **1500-2**). In response to detecting activation of the radio request control signal by the second transceiver, transmission access is granted (**2346**) to the second transceiver and transmission access is denied to the third transceiver. In some implementations, granting transmission access to the second transceiver and denying transmission access to the third transceiver includes (**2348**) activating the grant control signal (e.g., asserting WIFI\_GRANT signal on control line **1500-3**, FIG. **15A**). A corresponding example of steps **2340** through **2348** is illustrated in FIGS. **15G-1**.

In some implementations, while detecting the activated priority control signal, a transmission request is detected (**2350**) by the third transceiver. In some implementations, the transmission request by the third transceiver is detected (**2352**) while transmission access is granted to the second transceiver. In response to detecting the transmission request by the third transceiver, and while detecting the activated radio request control signal by the second transceiver, transmission access continues (**2354**) to be granted to the second transceiver while transmission access continues to be denied to the third transceiver. Thus, in some implementations, while the priority control signal is activated, the third transceiver is not permitted to transmit data.



In some implementations, while continuing to detect the activated radio request control signal and the activated priority control signal, transmission access continues (2356) to be granted to the second transceiver and transmission access continues to be denied to the third transceiver.

Referring now to FIG. 23D, in some implementations, while detecting the activated priority control signal, deactivation of the radio request control by the second transceiver is detected (2360) (e.g., de-assertion of RADIO\_REQ signal on control line 1500-2). In response to detecting deactivation of the radio request control signal by the second transceiver, transmission access to the second transceiver is revoked (2362) and transmission access to the third transceiver is granted. In some implementations, revoking transmission access to the second transceiver and granting transmission access to the third transceiver includes (2364) deactivating the grant control signal (e.g., de-asserting WIFI\_GRANT signal on control line 1500-3). A corresponding example of steps 2360 through 2364 is illustrated in FIGS. 15G-1.

In some implementations, a deactivated priority control signal is detected (2366) (e.g., an already de-asserted RADIO\_PRI signal on control line 1500-1 is detected). While detecting the deactivated priority control signal (2368), activation of the radio request control signal by the second transceiver is detected (2370). In response to detecting activation of the radio request control signal by the second transceiver, transmission access is granted (2372) to the second transceiver and transmission access is denied to the third transceiver. In some implementations, while transmission access is granted to the second transceiver, a transmission request by the third transceiver is detected (2374). In some implementations, the transmission request by the third transceiver is detected (2376) while detecting the activated radio request control signal. In some implementations, the transmission request by the third transceiver is (2378) a high priority transmission request (e.g., a transmission request within an access category above BE (Best Effort), VI (Video), and/or VO (Voice)). In response to detecting the transmission request by the third transceiver, transmission access is revoked (2380) to the second transceiver and transmission access is granted to the third transceiver. In some implementations, while transmission access is granted to the third transceiver, a high priority transmission by the third transceiver is detected (2382) to be in progress. Upon completion of the high priority transmission, transmission access is granted (2384) to the second transceiver and transmission access is revoked to the third transceiver. A corresponding example of steps 2366 through 2384 is illustrated in FIGS. 15E-1.

In some implementations, the camera device communicates (2302) using the first transceiver, communicates (2308) with one or more smart home devices using the second transceiver, and communicates (2318) using the third transceiver (where the steps 2302, 2308, and 2318 may be performed in accordance with any of the implementations described with respect to FIGS. 23A-23B).

For situations in which the systems discussed above collect information about users, the users may be provided with an opportunity to opt in/out of programs or features that may collect personal information (e.g., information about a user's preferences or usage of a smart device). In addition, in some implementations, certain data may be anonymized in one or more ways before it is stored or used, so that personally identifiable information is removed. For example, a user's identity may be anonymized so that the personally identifiable information cannot be determined for or associated with the user, and so that user preferences or user interactions are

generalized (for example, generalized based on user demographics) rather than associated with a particular user.

Although some of various drawings illustrate a number of logical stages in a particular order, stages that are not order dependent may be reordered and other stages may be combined or broken out. While some reordering or other groupings are specifically mentioned, others will be obvious to those of ordinary skill in the art, so the ordering and groupings presented herein are not an exhaustive list of alternatives. Moreover, it should be recognized that the stages could be implemented in hardware, firmware, software or any combination thereof.

The foregoing description, for purpose of explanation, has been described with reference to specific implementations. However, the illustrative discussions above are not intended to be exhaustive or to limit the scope of the claims to the precise forms disclosed. Many modifications and variations are possible in view of the above teachings. The implementations were chosen in order to best explain the principles underlying the claims and their practical applications, to thereby enable others skilled in the art to best use the implementations with various modifications as are suited to the particular uses contemplated.

What is claimed is:

1. A camera assembly, comprising:

an enclosed housing having a rear surface, a front surface, and a periphery, wherein the periphery defines a border of the enclosed housing, and the periphery includes an inner surface and an outer surface;

a lens module located within the enclosed housing and configured to receive light via the front surface;

communication circuitry located within the enclosed housing and configured to wirelessly communicate over a plurality of different communication protocols, the communication circuitry including one or more transceivers configured for communication over a first communication protocol and a second communication protocol;

a first antenna arranged at a first location on the inner surface of the periphery, the first antenna configured for communication over the first communication protocol, and the first antenna being electrically coupled to the communication circuitry; and

a second antenna arranged at a second location on the inner surface of the periphery, the second location being different than the first location, the second antenna configured for communication over the second communication protocol, and the second antenna being electrically coupled to the communication circuitry.

2. The camera assembly of claim 1, further comprising a loop arm that is configured to hold the enclosed housing when the enclosed housing is inserted within a cutout opening in the loop arm.

3. The camera assembly of claim 2, wherein the loop arm is made from metal material, and the first location of the first antenna and the second location of the second antenna are such that the impact from the presence of the metal loop arm is suppressed.

4. The camera assembly of claim 1, wherein the first antenna is arranged at the first location on the inner surface of the periphery and/or the second antenna is arranged at the second location on the inner surface of the periphery by an adhesive material.

5. The camera assembly of claim 1, wherein the first antenna and the second antenna are configured to operate at a same wireless transmission frequency.



6. The camera assembly of claim 1, wherein the first antenna and the second antenna are configured to operate at distinct wireless transmission frequencies.

7. The camera assembly of claim 1, wherein the one or more transceivers of the communication circuitry include a first transceiver configured for communication over the first communication protocol and a second transceiver configured for communication over the second communication protocol, wherein the first transceiver and the second transceiver are distinct.

8. The camera assembly of claim 1, wherein the communication circuitry is an integrated circuit configured for communication over both the first and second communication protocols.

9. The camera assembly of claim 1, wherein the communication circuitry is configured to wireless communicate over at least three different communication protocols.

10. The camera assembly of claim 9, wherein the second antenna is further configured for communication over a third one of the communication protocols.

11. The camera assembly of claim 10, wherein:  
the first antenna is configured to transmit and receive, over the first communication protocol, signals comprising one or more of alerts, control signals and status information to and from other smart home devices; and  
the second antenna is configured to transmit and receive, over the second communication protocol signals for configuring the smart home device, and over the third communication protocol data corresponding to video captured by the smart home device.

12. The camera assembly of claim 1, wherein the communication circuitry is further configured to provide transmis-

sion access for communicating over the first communication protocol while denying transmission access for communicating over the second communication protocol, while detecting an activated priority control signal.

13. The camera assembly of claim 1, wherein the first antenna has a first orientation and the second antenna has a second orientation such that the impact from the presence and interference of each other antenna are suppressed.

14. The camera assembly of claim 1, wherein the first antenna or the second antenna is configured to transmit and receive wireless signals in a wireless local area network according to the IEEE 802.11 standard.

15. The camera assembly of claim 1, wherein the first antenna or the second antenna is configured to transmit and receive wireless signals in a wireless personal area network according to the IEEE 802.15.4 standard.

16. The camera assembly of claim 1, wherein the first antenna or the second antenna is configured to transmit and receive wireless signals according to the Bluetooth Low Energy standard.

17. The camera assembly of claim 1, wherein the first antenna and the second antenna are electrically coupled to a duplex that controls their connections to a single wireless receiver circuit.

18. The camera assembly of claim 1, wherein video data captured by the lens module is exchanged between the camera assembly and a server using a wireless local area network.

19. The camera assembly of claim 1, wherein the first antenna and the second antenna are marked with a respective alignment mark that is configured to guide the assembly of the respective antenna onto the interior wall of the camera lid.

\* \* \* \* \*



UNITED STATES PATENT AND TRADEMARK OFFICE  
**CERTIFICATE OF CORRECTION**

PATENT NO. : 9,396,633 B1  
APPLICATION NO. : 14/819373  
DATED : July 19, 2016  
INVENTOR(S) : Sannala

Page 1 of 1

It is certified that error appears in the above-identified patent and that said Letters Patent is hereby corrected as shown below:

In the title page, (57) Abstract, line 6, please delete “to wireless communicate” and insert --to wirelessly communicate--;

In the claims, claim 9, column 59, line 16, please delete “to wireless communicate” and insert --to wirelessly communicate--.

Signed and Sealed this  
Twenty-fifth Day of October, 2016



Michelle K. Lee  
*Director of the United States Patent and Trademark Office*