



US009386966B2

(12) **United States Patent**  
**Tripp et al.**

(10) **Patent No.:** **US 9,386,966 B2**  
(45) **Date of Patent:** **Jul. 12, 2016**

(54) **METHODS AND APPARATUS FOR TISSUE REMOVAL**  
(75) Inventors: **Hugh Tripp**, Mansfield, MA (US);  
**Thomas R. Johnson**, Milford, NH (US)  
(73) Assignee: **Theragenics Corporation**, Buford, GA (US)  
(\* ) Notice: Subject to any disclaimer, the term of this patent is extended or adjusted under 35 U.S.C. 154(b) by 146 days.

(21) Appl. No.: **14/123,394**  
(22) PCT Filed: **Jun. 3, 2012**  
(86) PCT No.: **PCT/US2012/040643**  
§ 371 (c)(1),  
(2), (4) Date: **Dec. 2, 2013**  
(87) PCT Pub. No.: **WO2012/167216**  
PCT Pub. Date: **Dec. 6, 2012**

(65) **Prior Publication Data**  
US 2014/0100479 A1 Apr. 10, 2014  
**Related U.S. Application Data**  
(60) Provisional application No. 61/492,946, filed on Jun. 3, 2011.  
(51) **Int. Cl.**  
**A61B 5/00** (2006.01)  
**A61B 10/02** (2006.01)  
(Continued)

(52) **U.S. Cl.**  
CPC ..... **A61B 10/0266** (2013.01); **A61B 2010/0208** (2013.01); **A61B 2017/00867** (2013.01); **A61B 2017/3405** (2013.01)

(58) **Field of Classification Search**  
CPC ..... **A61B 10/02**; **A61B 10/0233**; **A61B 10/0266**; **A61B 2010/0208**  
See application file for complete search history.

(56) **References Cited**  
U.S. PATENT DOCUMENTS  
2,516,492 A \* 7/1950 Turkel ..... A61B 10/0266  
600/564  
3,007,471 A 11/1961 McClure, Jr.  
(Continued)

FOREIGN PATENT DOCUMENTS  
EP 0852127 A1 7/1998  
EP 1136039 A2 9/2001  
(Continued)

OTHER PUBLICATIONS  
Dennler, Samuel, International Preliminary Report on Patentability dated Jul. 10, 2009, PCT Application No. PCT/IB2008/000827, 11 pages, European Patent Office, Munich, Germany.  
(Continued)

*Primary Examiner* — Max Hindenburg  
(74) *Attorney, Agent, or Firm* — John J Brooks, III; John Brooks Law LLC

(57) **ABSTRACT**  
A tissue removal apparatus and needle assembly for extracting a tissue portion from tissue or the like, the needle assembly comprising an inner tube having an interior cavity, an outer cannula having a proximal end, a distal end and an interior cavity, the interior cavity of the outer cannula having an interior diameter to slidably receive the inner tube and a collapsible section operably engaged with the inner tube and the outer cannula whereby a forward movement of a portion of the inner tube within the interior cavity of the outer cannula changes the collapsible section from a neutral position to a collapsed position to engage the tissue portion. A method of tissue removal comprising the steps of positioning a needle assembly in a tissue, engaging a tissue portion and withdrawing the needle assembly to remove the tissue portion from the tissue.

**35 Claims, 11 Drawing Sheets**

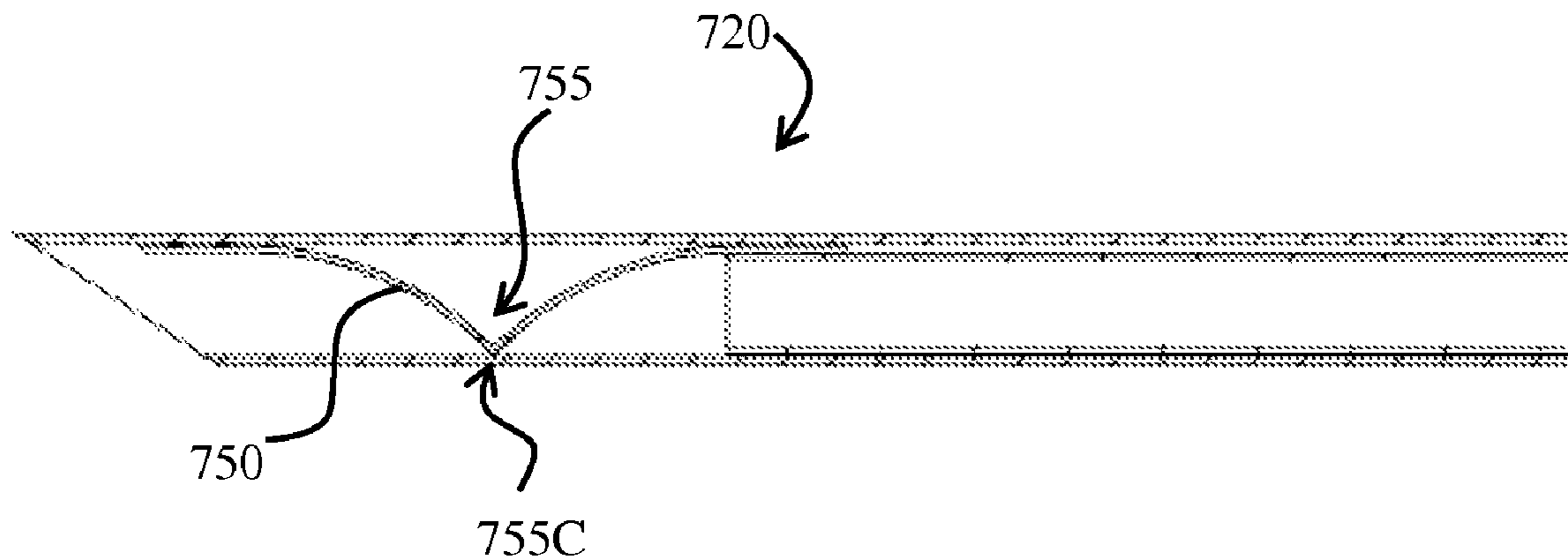



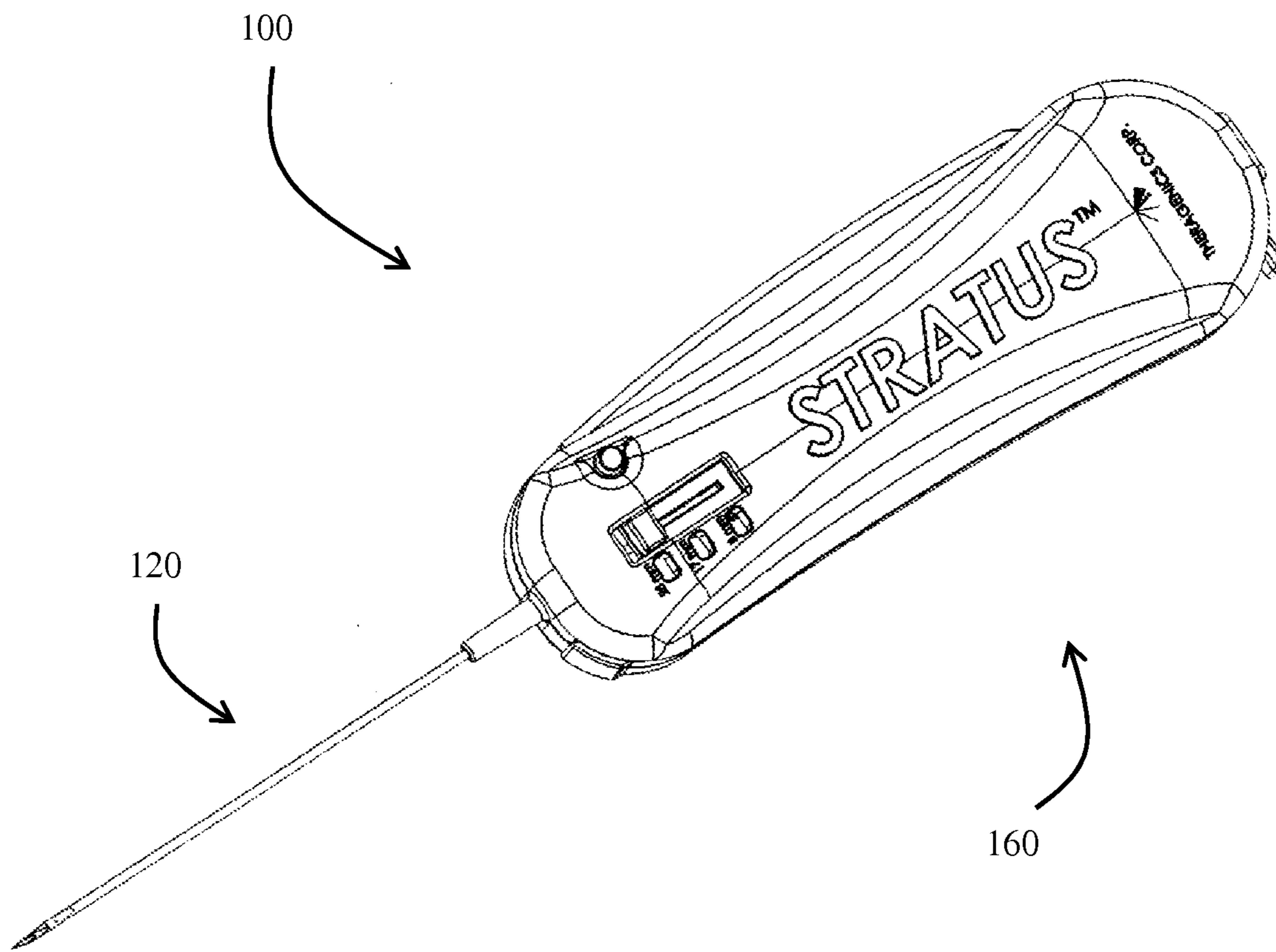
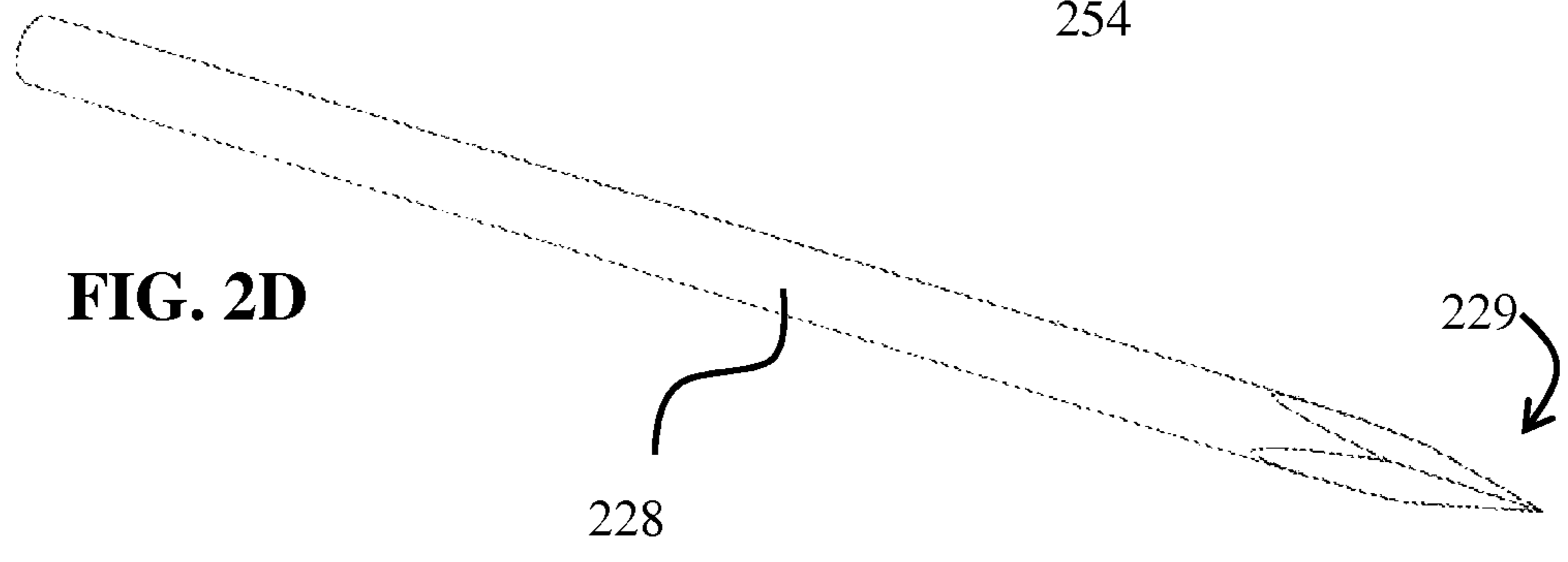
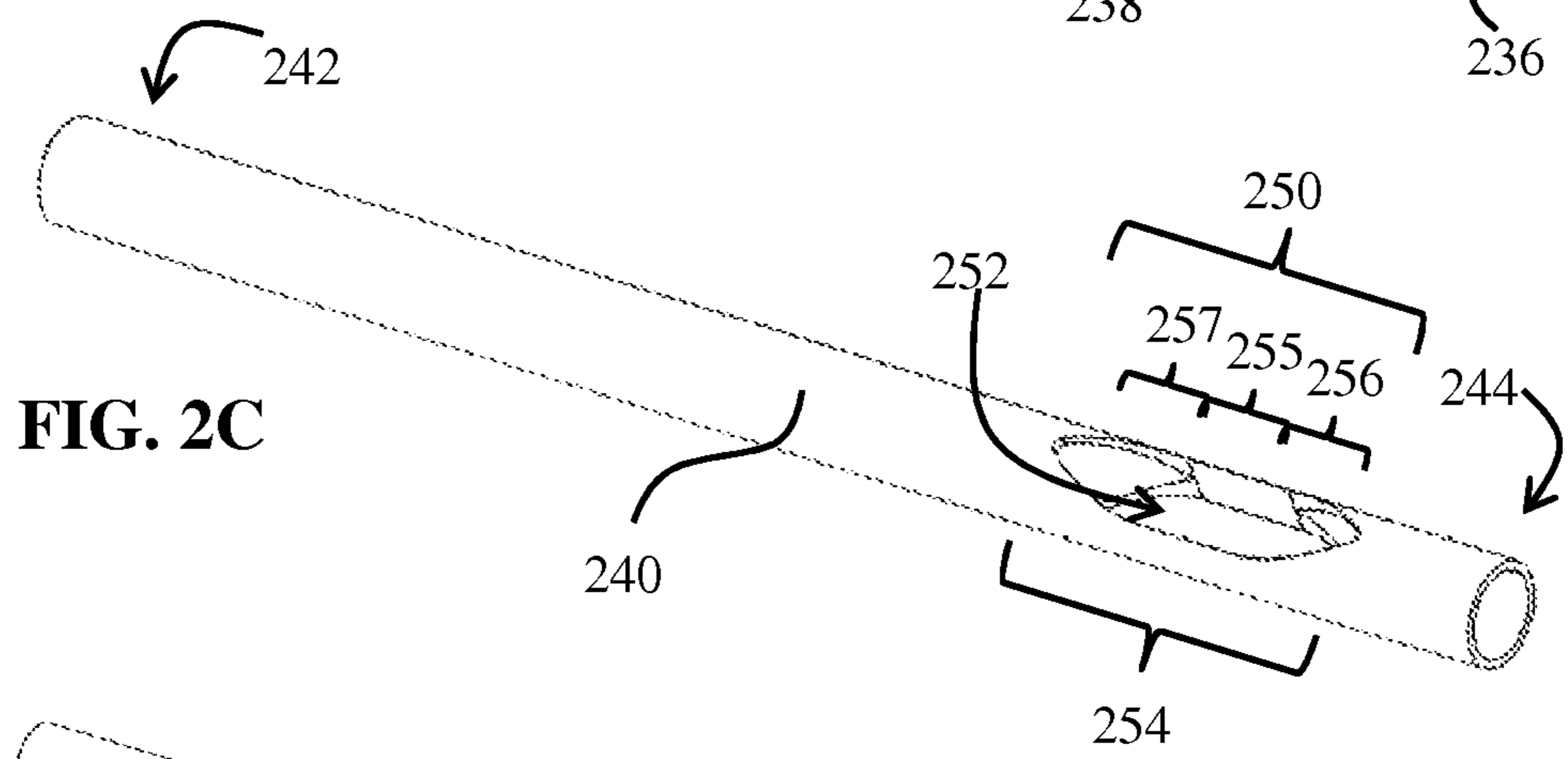
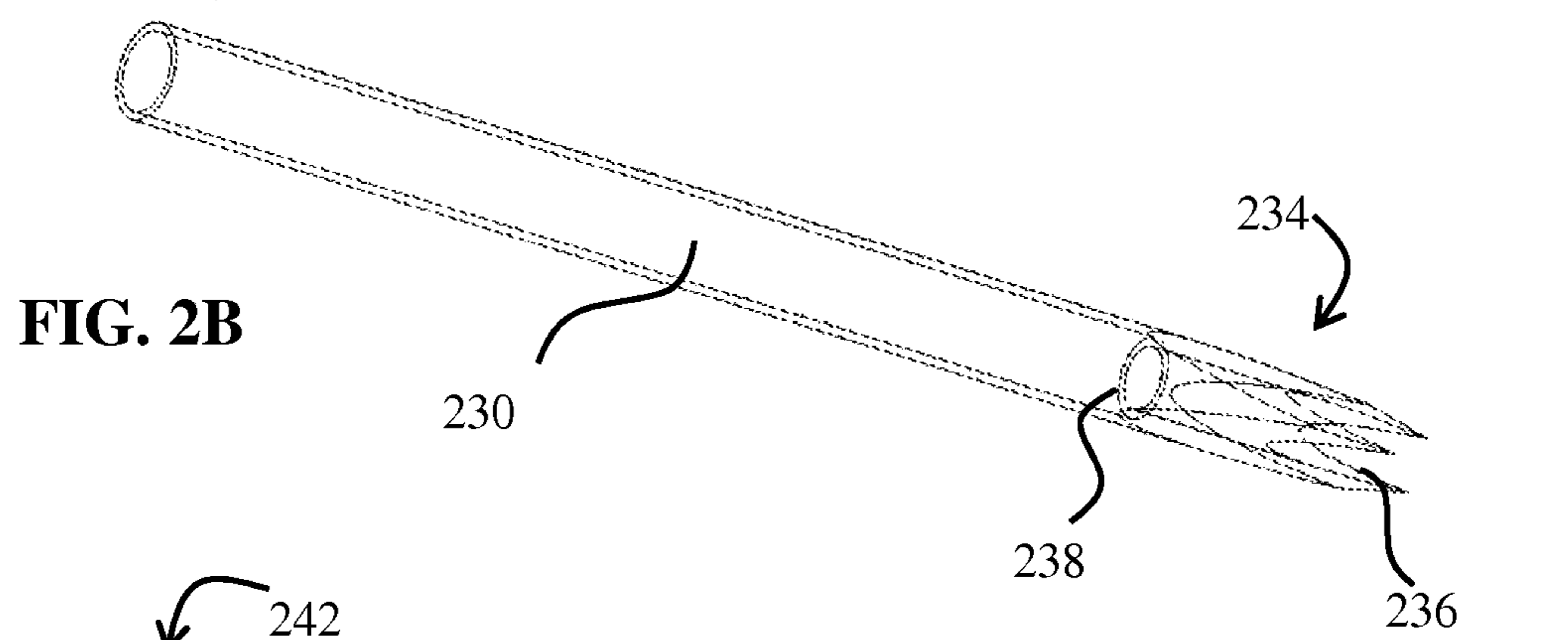
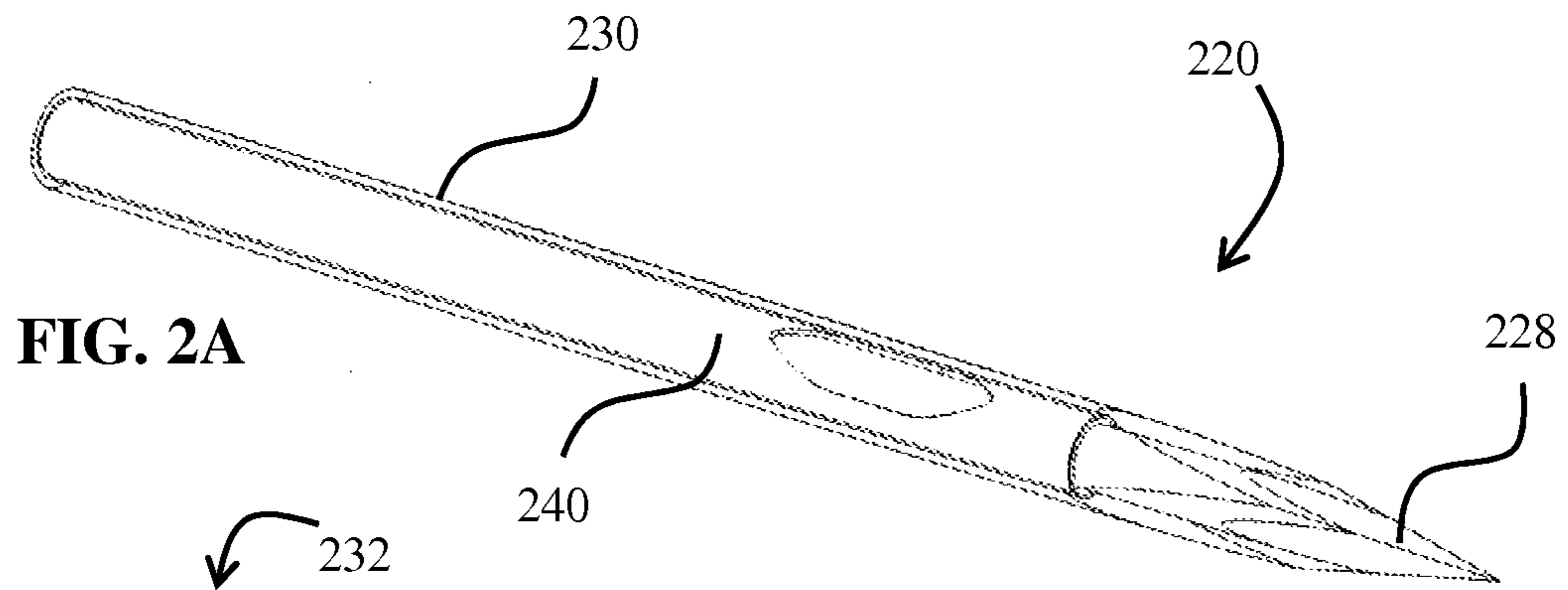
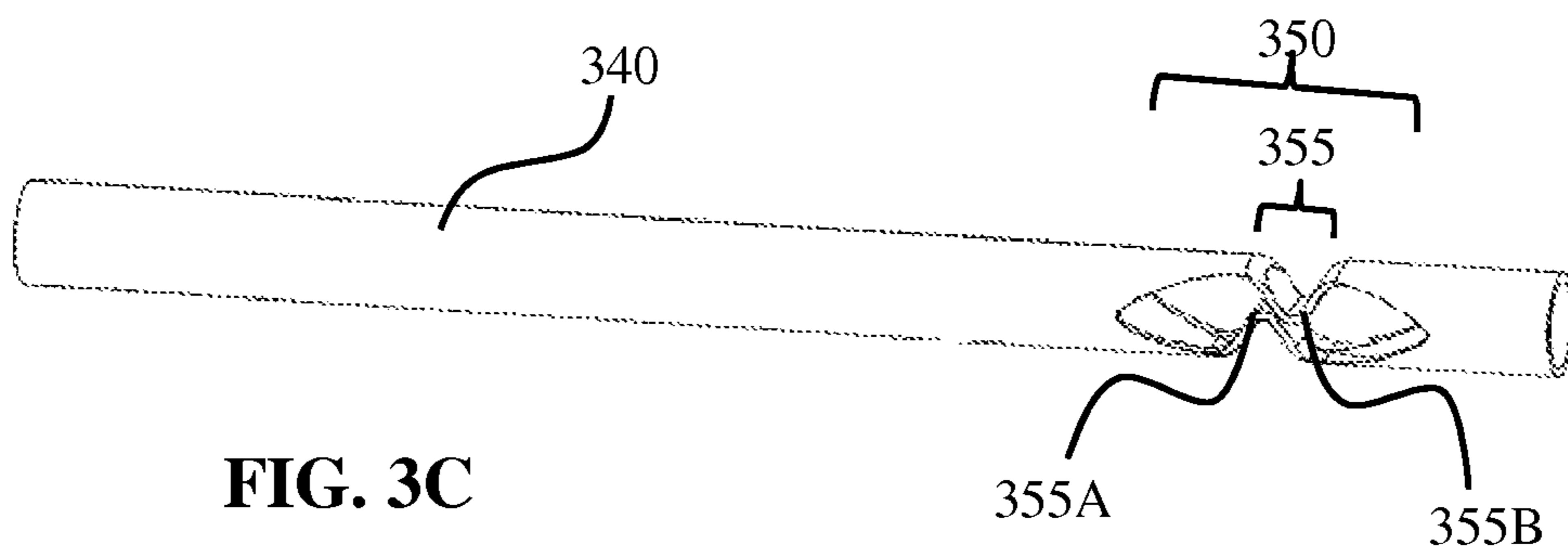
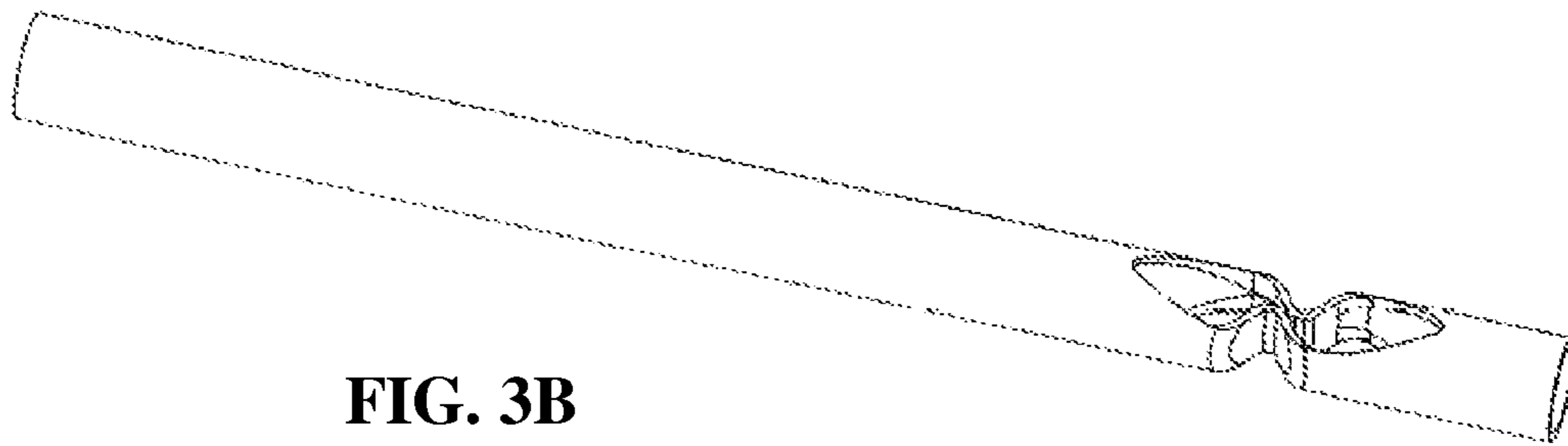
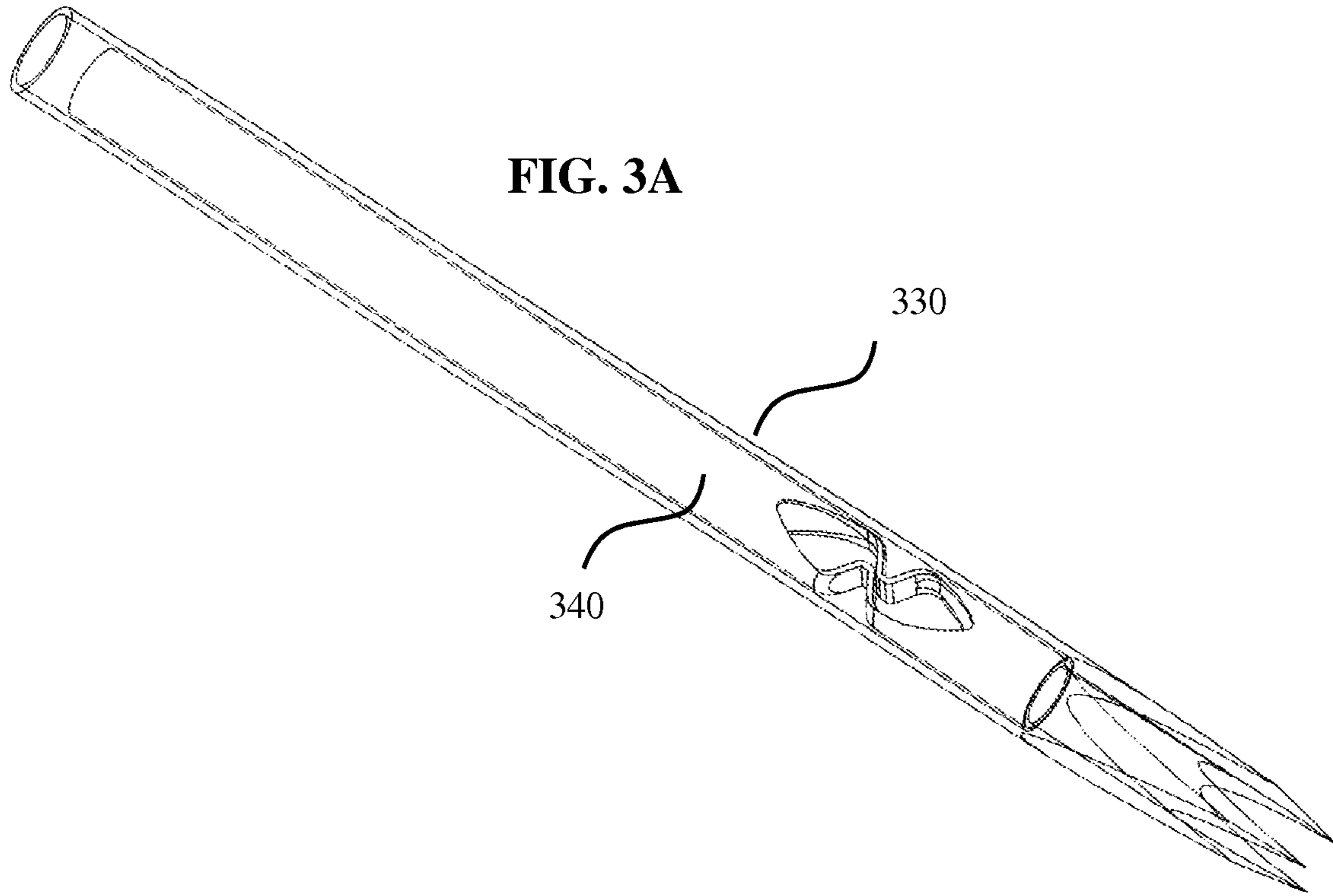

FIG. 1





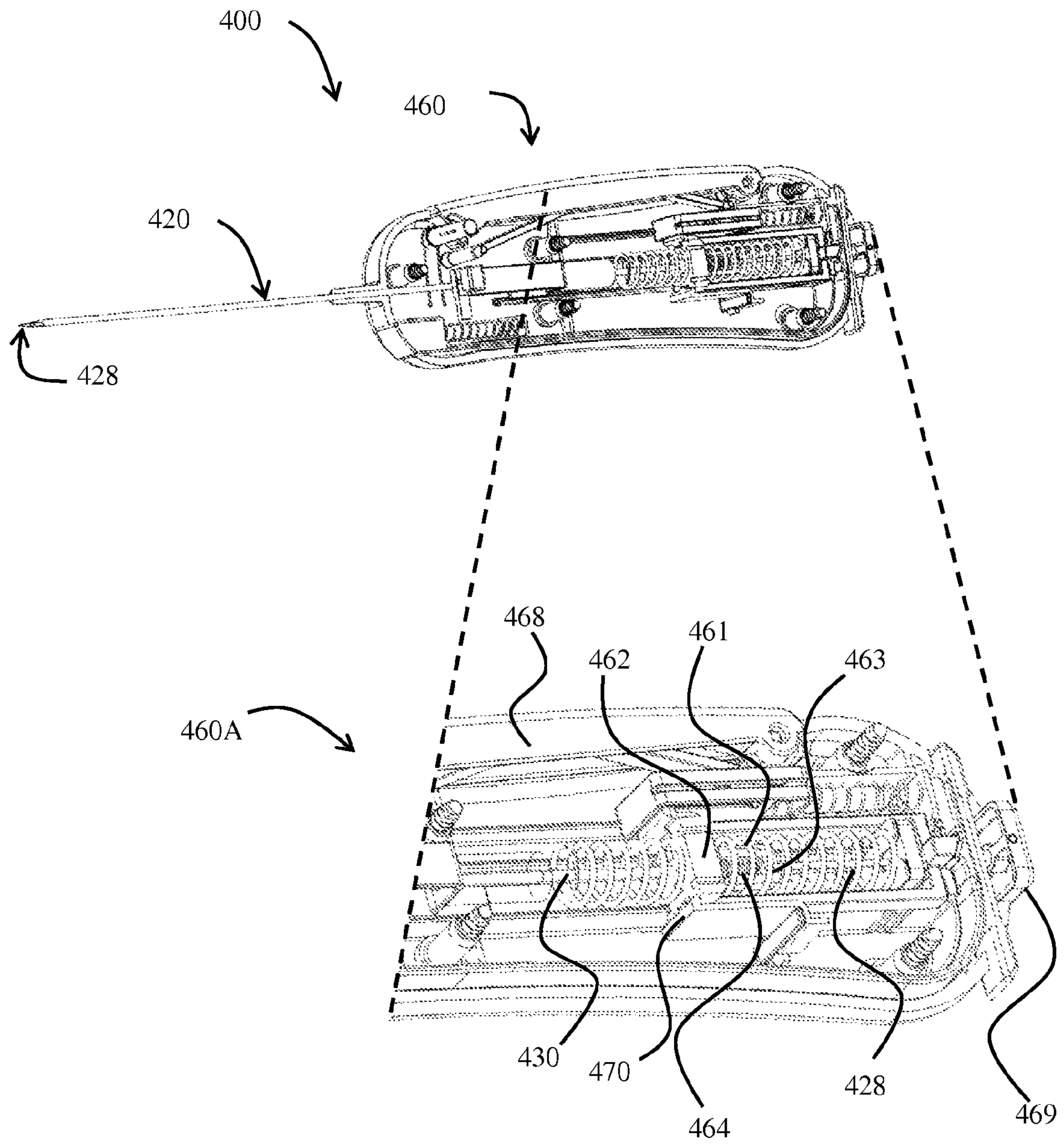

FIG. 4

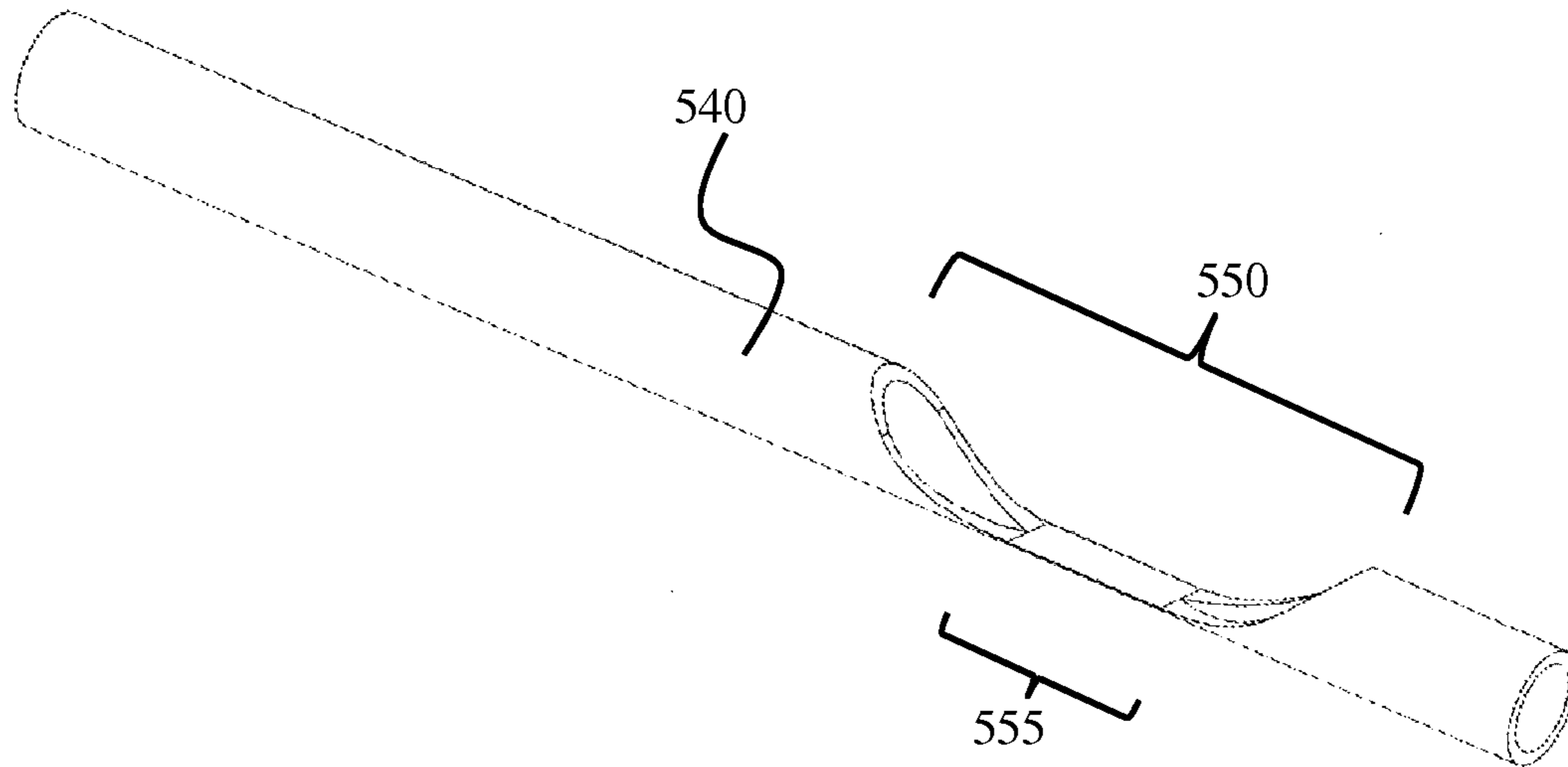

FIG. 5A

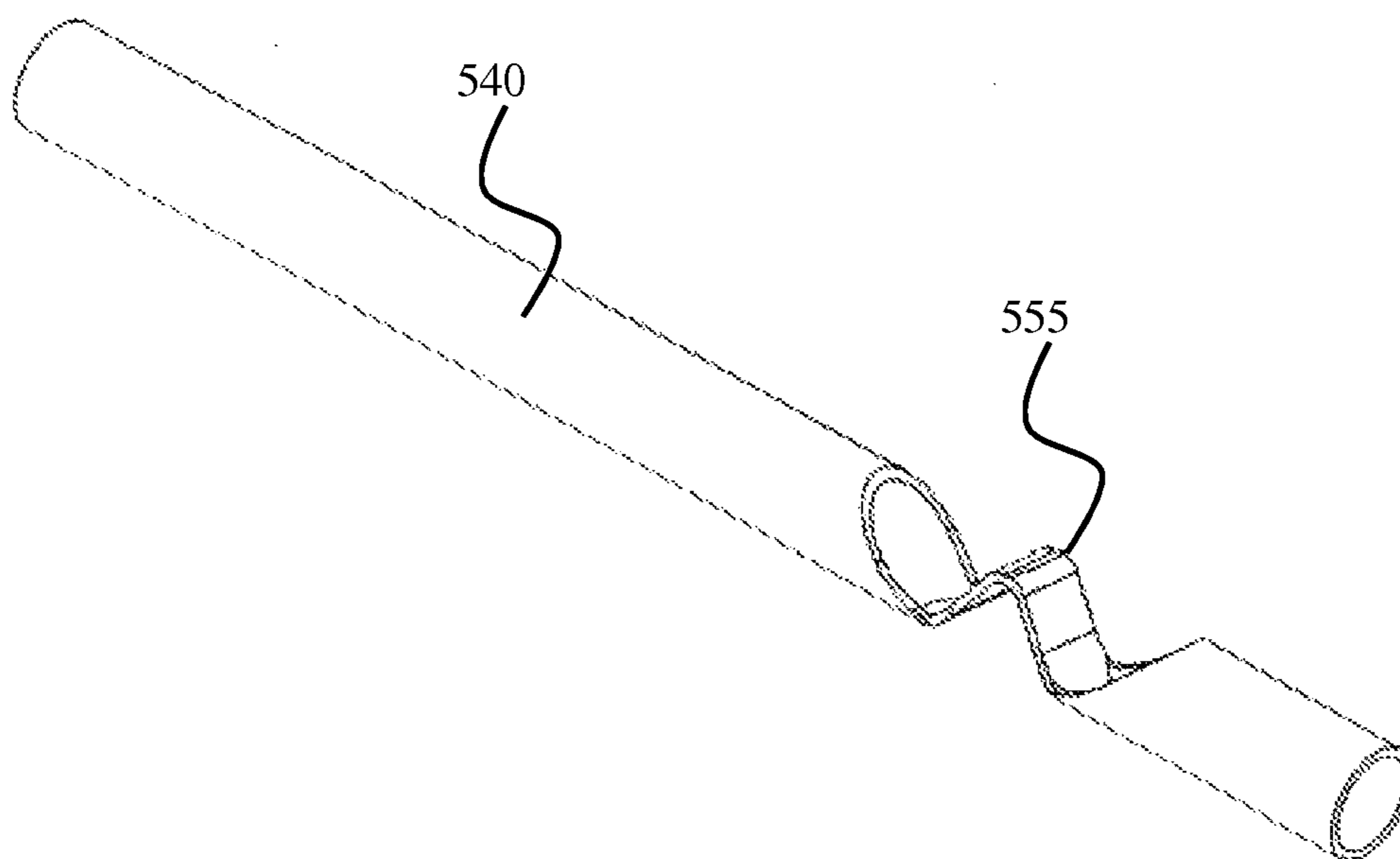

FIG. 5B

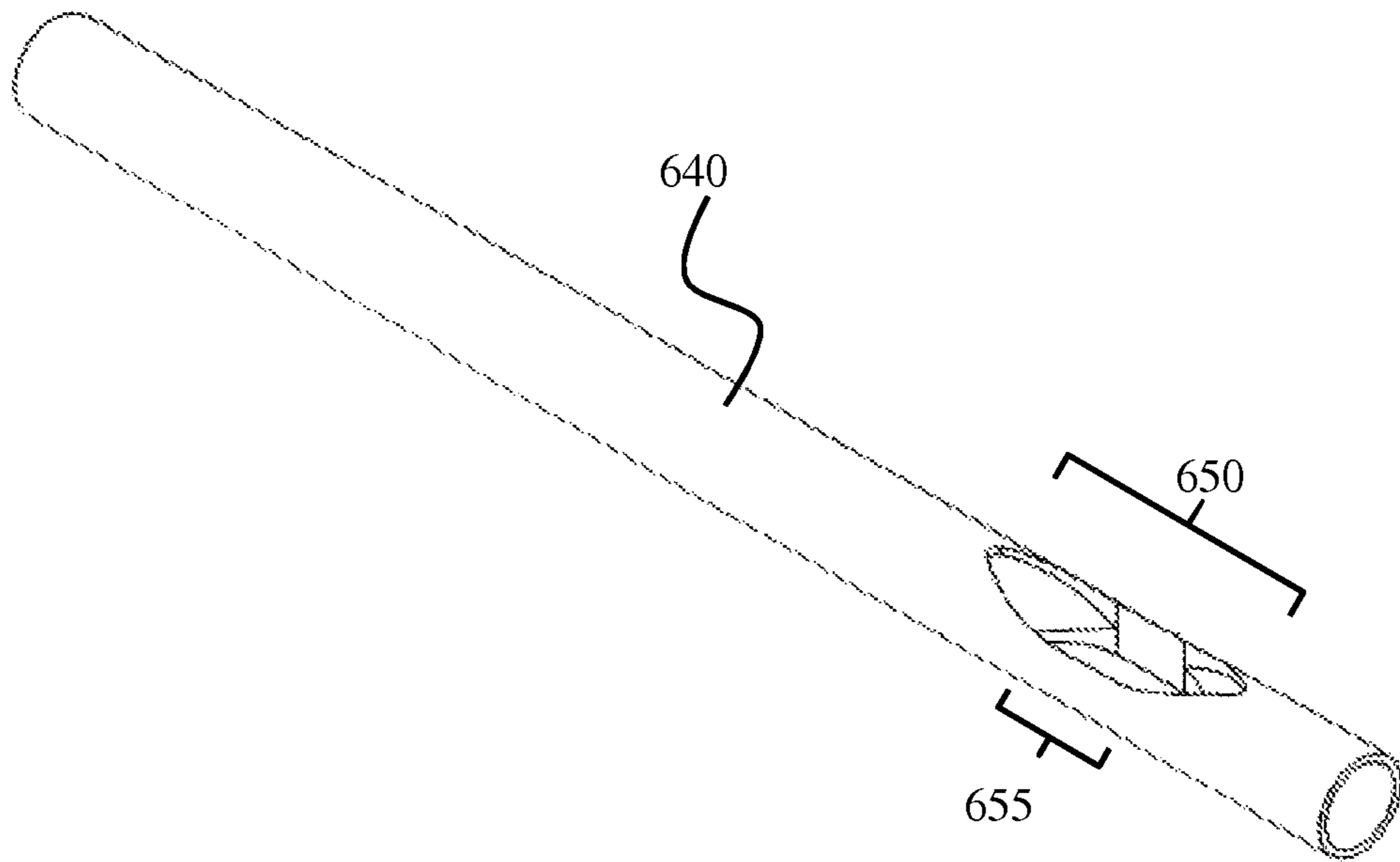

FIG. 6A

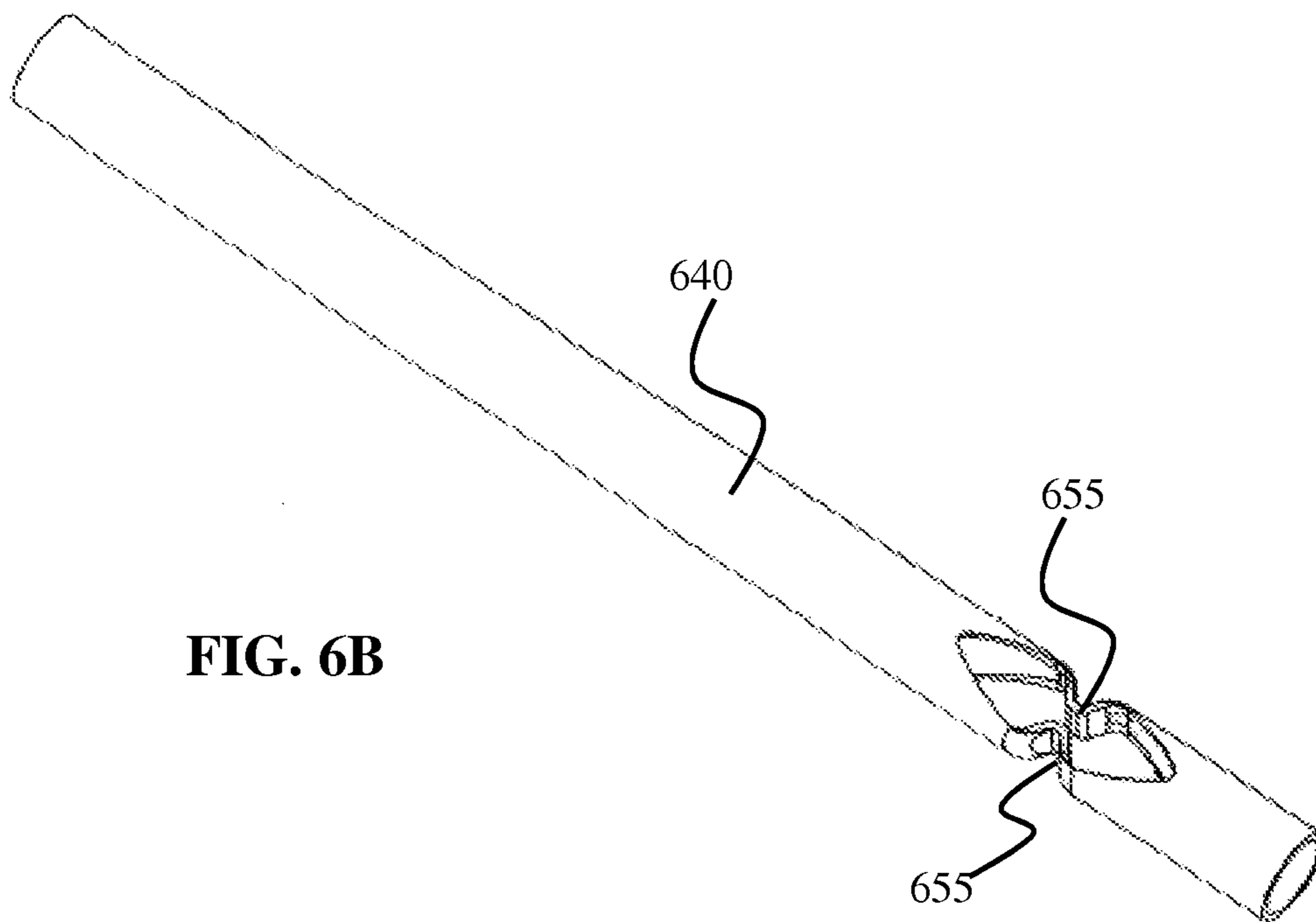

FIG. 6B



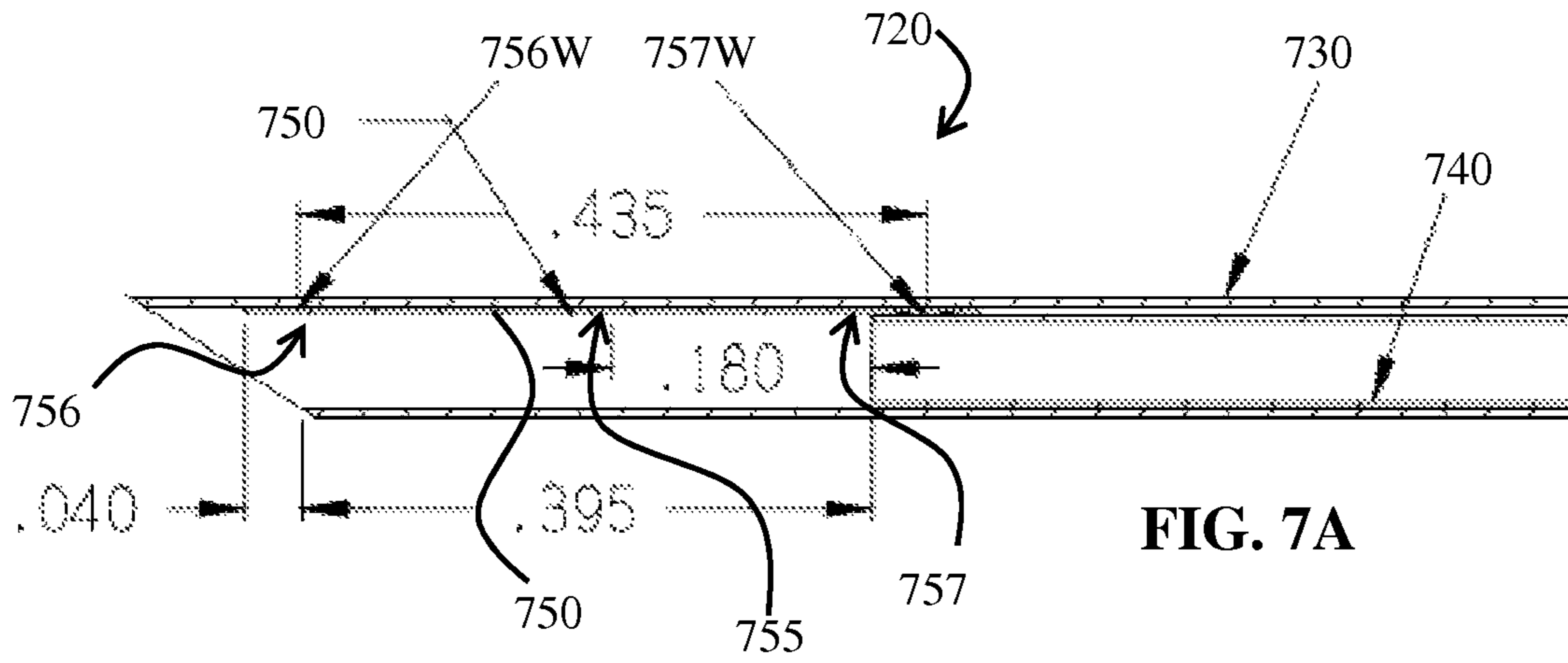

FIG. 7A

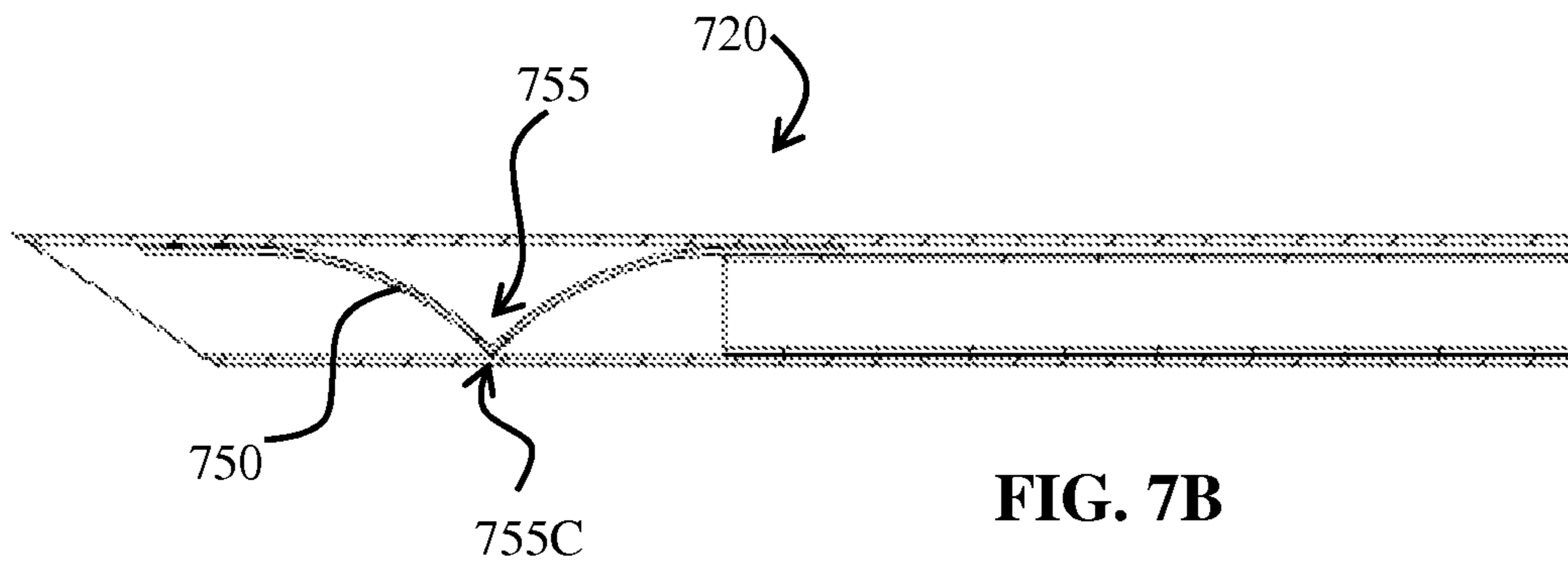

FIG. 7B

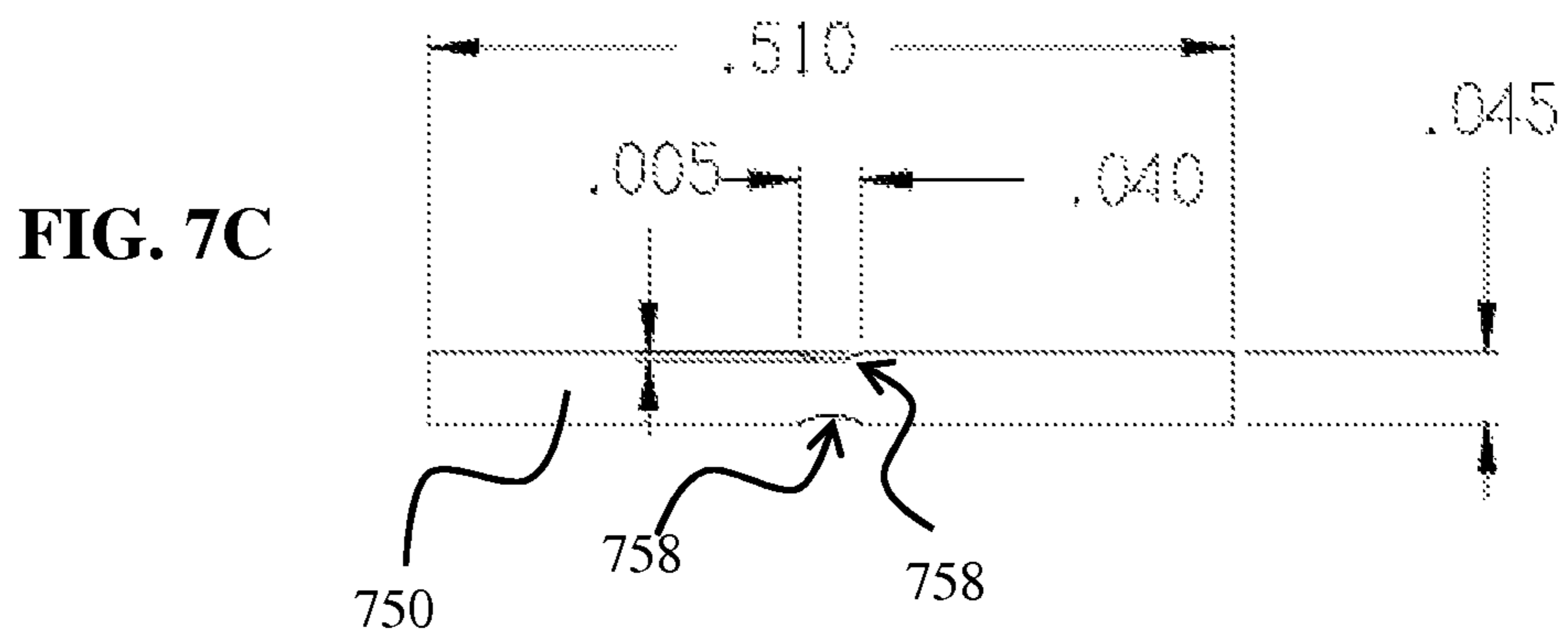

FIG. 7C

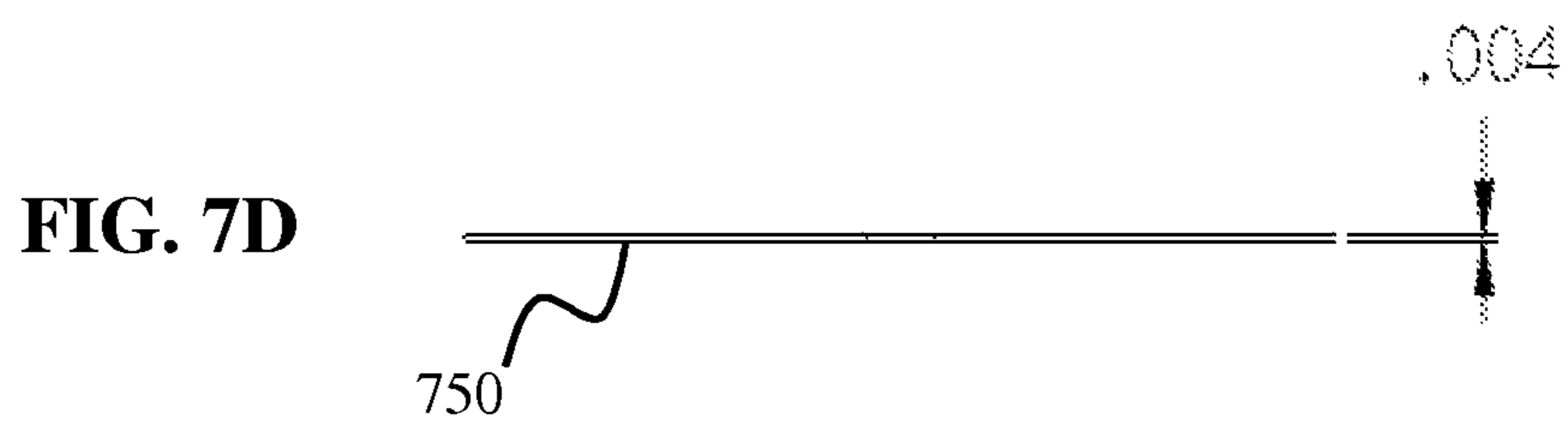

FIG. 7D

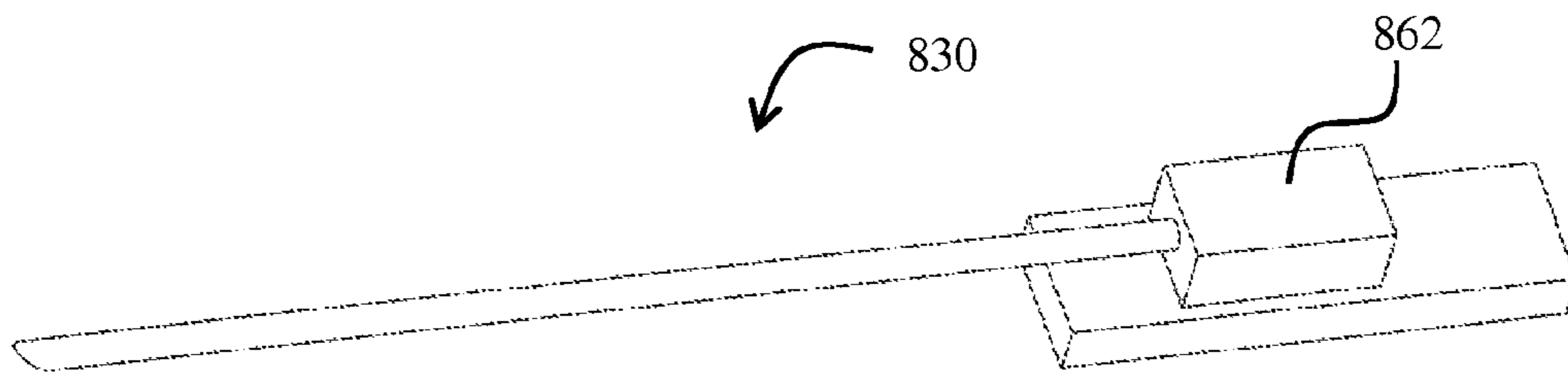

FIG. 8A

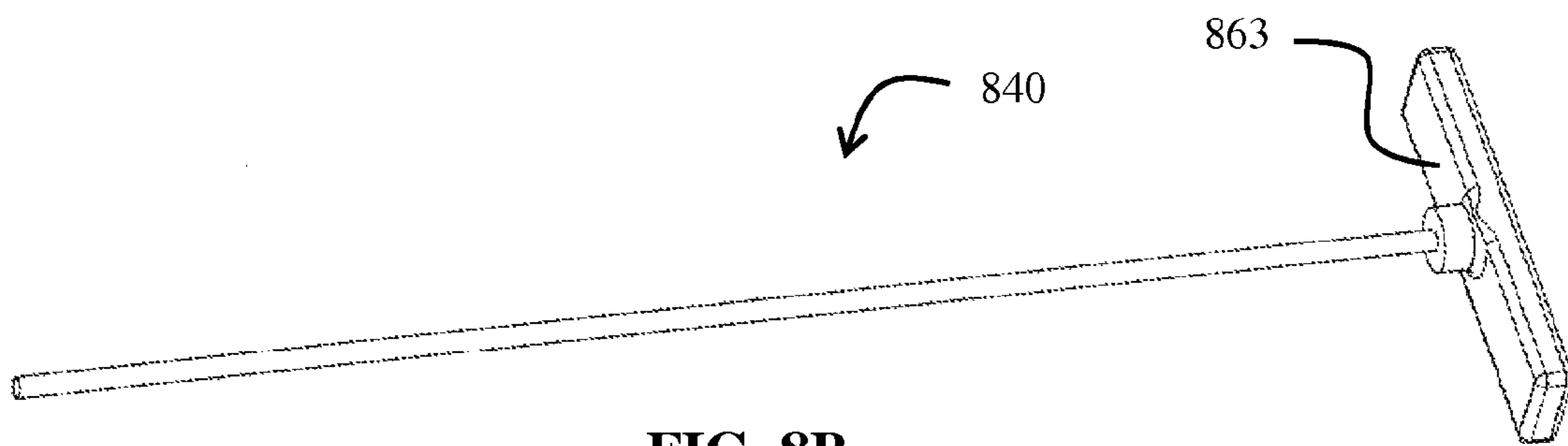

FIG. 8B



FIG. 8C

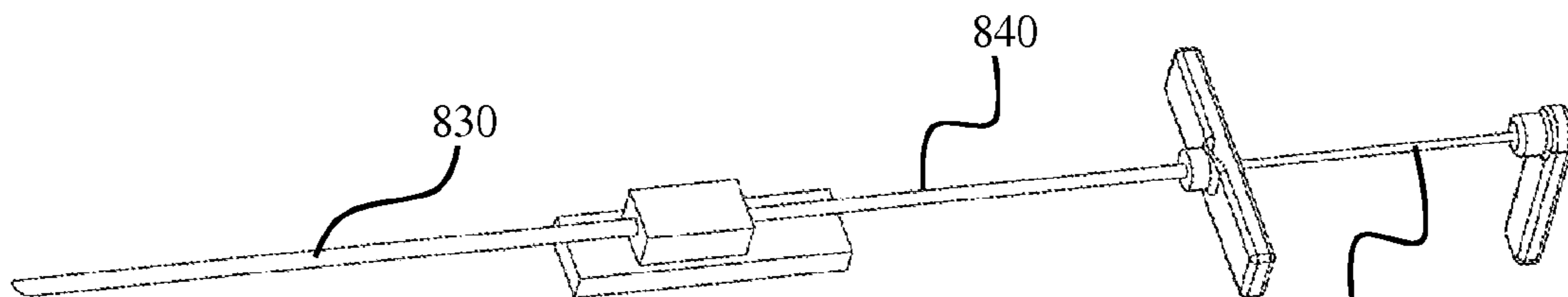

FIG. 8D

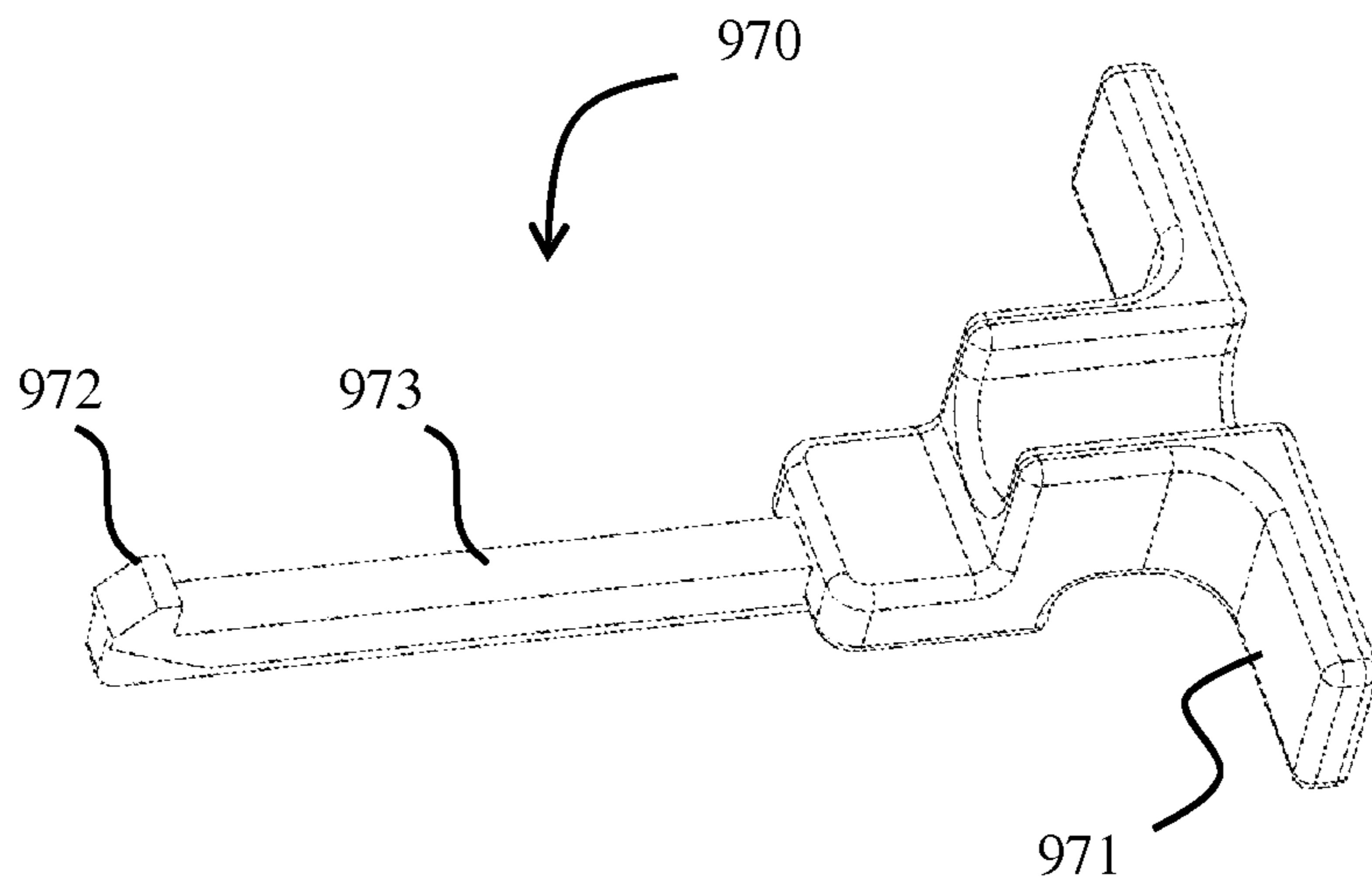

FIG. 9A

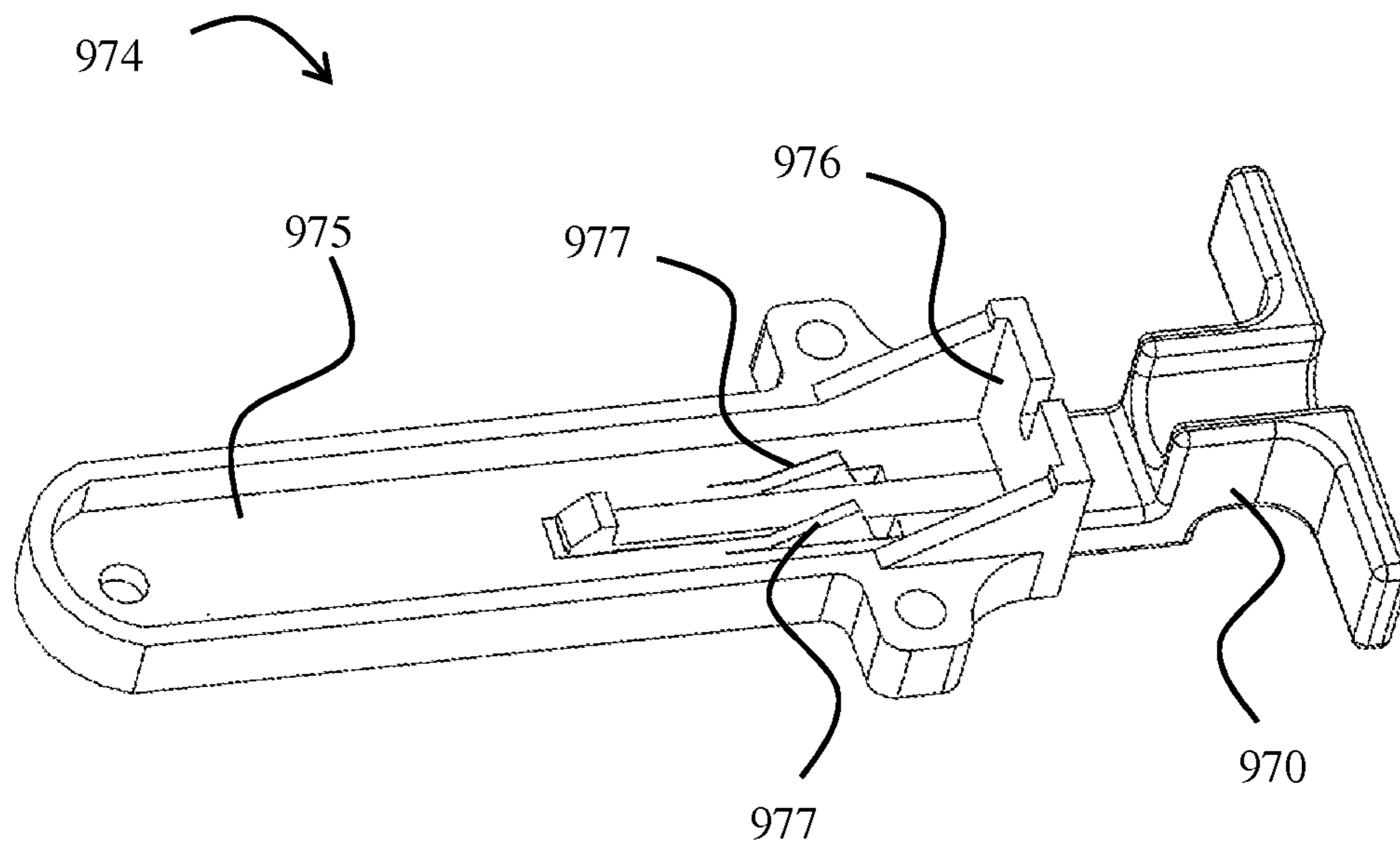

FIG. 9B

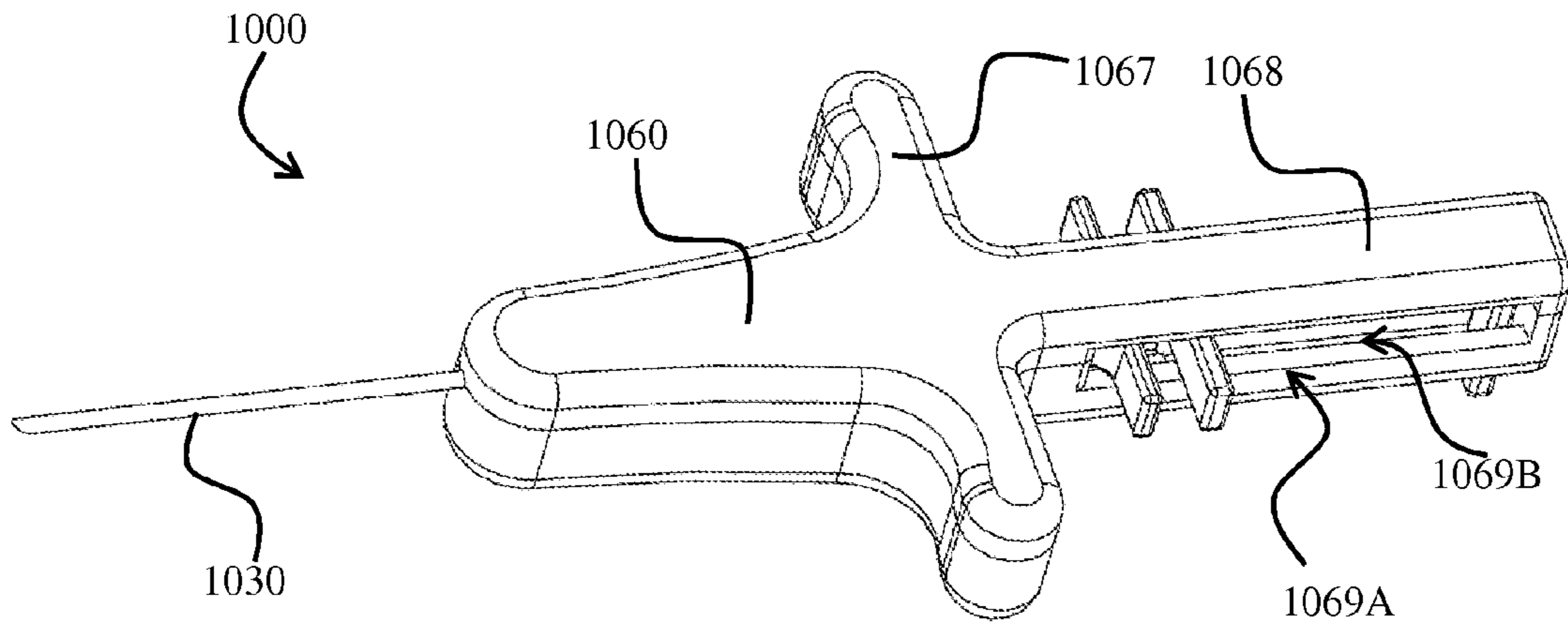

FIG. 10A

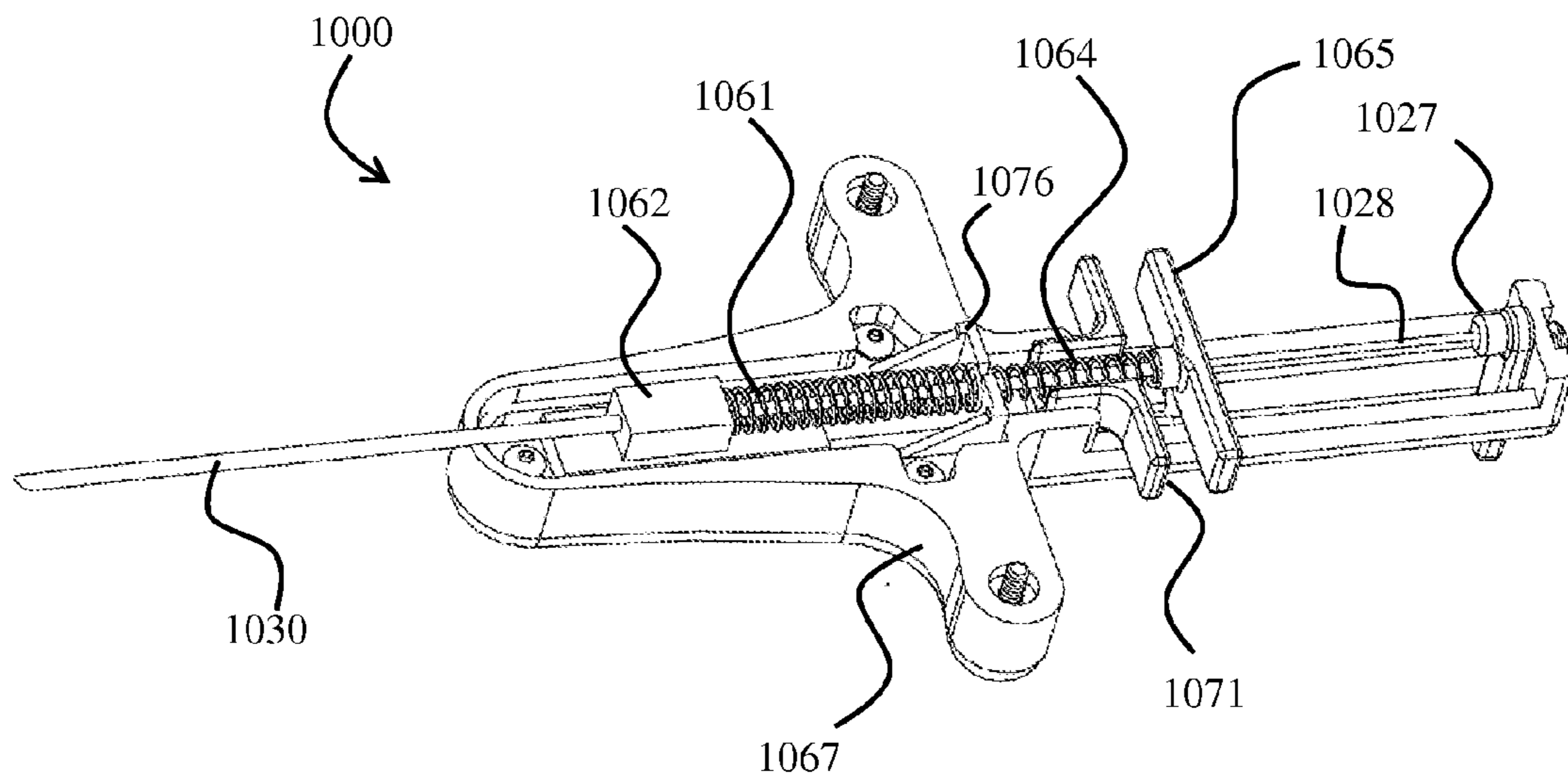

FIG. 10B

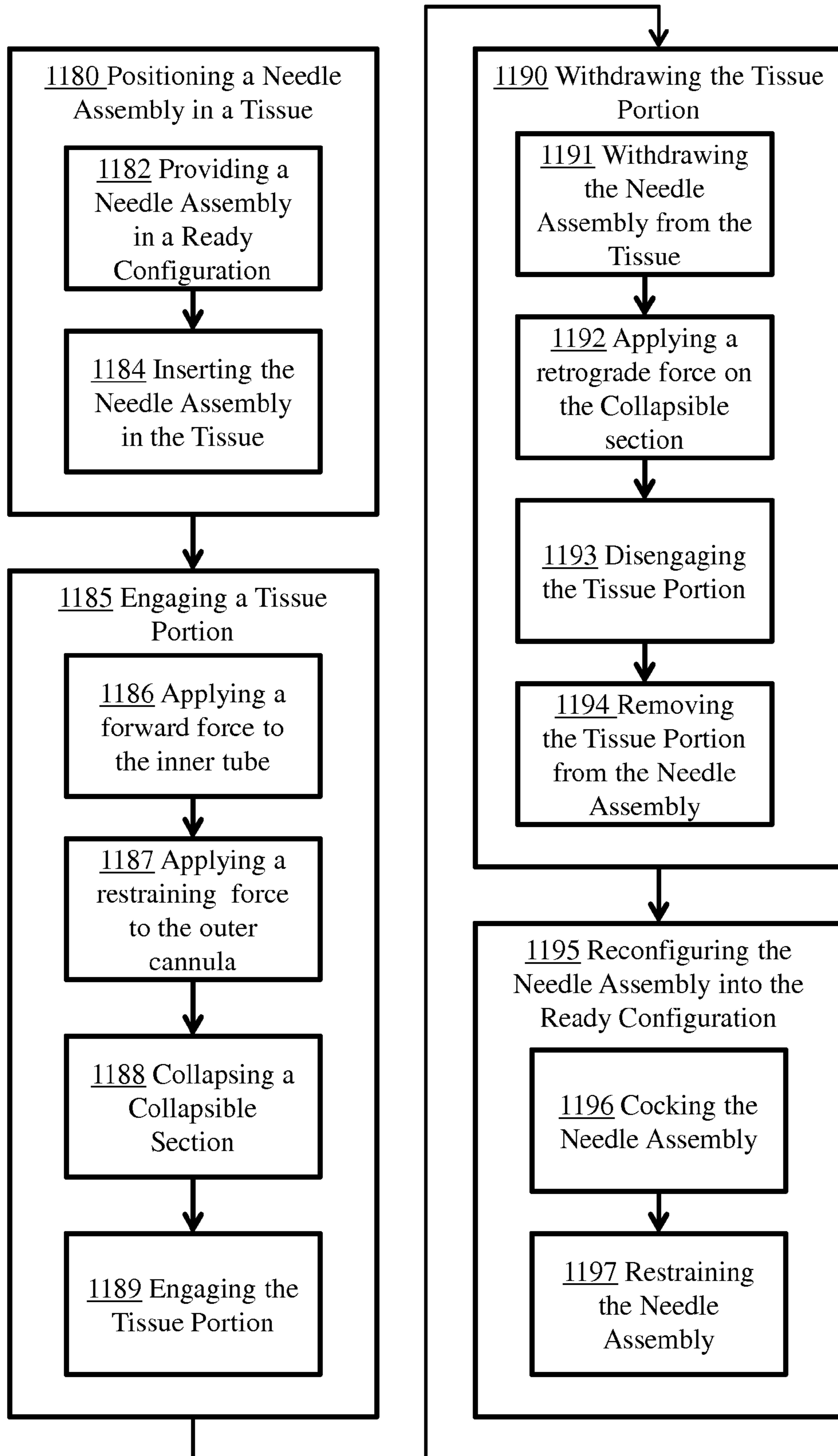

FIG. 11

## METHODS AND APPARATUS FOR TISSUE REMOVAL

### CROSS-REFERENCE TO RELATED APPLICATIONS

This application claims benefit to U.S. Pat. App. No. 61/492,946 filed Jun. 3, 2011 entitled "METHOD AND APPARATUS FOR TISSUE REMOVAL", the entire contents of which are herein incorporated by reference.

### STATEMENT REGARDING FEDERALLY SPONSORED RESEARCH OR DEVELOPMENT

Not Applicable

### REFERENCE TO SEQUENCE LISTING, A TABLE, OR A COMPUTER PROGRAM LISTING COMPACT DISC APPENDIX

Not Applicable

### BACKGROUND OF THE INVENTION

This invention relates to the removal of tissue samples or the like from humans or animals, in particular by excising a tissue portion from a tissue.

Biopsy devices are employed in modern medicine to collect tissue samples for examination typically for diagnosis of malignant or pre-malignant cell transformations indicating cancerous or pre-cancerous tumors. The procedure entails identifying the suspect tissue, bringing the biopsy device close to the tissue and depending on the type of action employed to cut and retain the required sample by firing a needle or cannula into the tissue and following up with a secondary action to sever and retain the sample tissue.

While there are multiple examples of biopsy devices currently being used to obtain tissue material for histological examination, the preservation of the sample with respect to tissue quality is sometimes compromised by the mechanical actions employed.

Some of the earlier Automated Core Biopsy Devices used a notched needle to obtain samples. However these yielded limited quantities due to the half round needle as shown in U.S. Pat. No. 4,699,154 to Radiplast AB, issued Oct. 13, 1987, also known as the "Tru-Cut" needle, which is herein incorporated by reference in its entirety. Others, in an attempt to retrieve full round core have utilized various means to cut and capture those round cores either by vacuum or a series of fingers cut in the wall of the cannula and depressed inward as shown in Patent Application Publication US 2008/0300507 to Stacy Figueredo et al. published Dec. 4, 2008 or in U.S. Pat. No. 5,655,542 to Anders Weilandt issued Aug. 12, 1997 and U.S. Pat. No. 6,322,523 to Anders Weilandt issued Nov. 27, 2011 by means of an outer cannula with finger like projections that slide into windows cut in an inner tube. All publications and patents mentioned above are herein incorporated by reference in their entirety.

U.S. Pat. Pub. No. 20100160827, published Jun. 24, 2010, for U.S. patent application Ser. No. 12/594,835 having a §371 date of Jan. 27, 2010, to Odoardo Buressiniani ("Buressiniani"), which is herein incorporated by reference in its entirety, discloses a device having an outer cannula and an inner cannula having a plurality of ribs to engage a tissue sample.

U.S. Pat. No. 6,416,484, issued Jul. 9, 2002 to Michael E. Miller et al ("Miller"), which is herein incorporated by reference in its entirety, discloses a biopsy extractor having an

outer cannula with a tapered end and an inelastically bendable portion to allow a head to sever and hold a tissue portion.

While these devices have worked to one degree or another, the issue of maintaining an intact tissue portion that is uncompromised by the engaging, cutting and retention means has not been addressed using the methods and means described herein.

### BRIEF SUMMARY OF THE INVENTION

The following summary is included only to introduce some concepts discussed in the Detailed Description below. This summary is not comprehensive and is not intended to delineate the scope of protectable subject matter, which is set forth by the claims presented.

One example embodiment of the present invention provides a needle assembly comprising an inner tube having an interior cavity, an outer cannula having a proximal portion, a distal portion and an interior cavity, the interior cavity of the outer cannula having an interior diameter to slidably receive the inner tube and an elastically collapsible leg operably engaged with the inner tube and the outer cannula whereby a forward movement of a portion of the inner tube within the interior cavity of the outer cannula changes the elastically collapsible leg from a neutral position to a collapsed position. In some embodiments, the elastically collapsible leg is formed from an elgiloy. In some embodiments, the elastically collapsible leg is formed from a super elastic material. In some embodiments, the elastically collapsible leg further comprises a cutting edge. In some embodiments, an interior cavity wall defines the interior cavity of the outer cannula, the elastically collapsible leg further comprises a cutting edge and the collapsed position positions the cutting edge across a portion of the interior cavity of the outer cannula and proximal to a portion of the interior cavity wall of the outer cannula. In some embodiments, the elastically collapsible leg is further configured to deform to the collapsed position by the forward movement of a proximal section of the elastically collapsible leg and by a restrained movement or lack of movement of a distal section of the elastically collapsible leg. In some embodiments, a smaller diameter portion of the interior cavity of the outer cannula defines a step configured to restrict movement of the distal section of the elastically collapsible leg. In some embodiments, the inner tube has a distal portion and a body portion and the elastically collapsible leg is coupled to the distal portion and the body portion of the inner tube. In some embodiments, the elastically collapsible leg is coupled to the distal portion of the inner tube by a first weld and the elastically collapsible leg is coupled to the body portion of the inner tube by a second weld. In some embodiments, the elastically collapsible leg is coupled to a distal portion of the inner tube and a distal portion of the outer cannula. In some embodiments, the elastically collapsible leg is coupled to the distal portion of the inner tube by a first weld and the elastically collapsible leg is coupled to the distal portion of the outer cannula by a second weld. In some embodiments, the needle assembly further comprises a first cam coupled to the proximal portion of the inner tube and a second cam coupled to the proximal portion of the outer cannula. In some embodiments, the needle assembly further comprises a holder assembly comprising a first spring and a second spring, the first spring configured to provide a first force on the first cam and the second spring configured to provide a second force on the second cam. In some embodiments, the needle assembly further comprises at least one additional collapsible leg. In some embodiments, the needle assembly further comprises a plunger slidably disposed

3

within the interior cavity of the inner tube. In some embodiment, the needle assembly further comprises a first cam coupled to the proximal portion of the inner tube, a second cam coupled to the proximal portion of the outer cannula, a third cam coupled to the plunger, a handle comprising a first spring and a second spring, the first spring configured to provide a first force on the first cam, the second spring configured to provide a second force on the second cam and the third cam configured to provide a third force on the plunger.

Another example embodiment of present invention provides an inner tube for use with a biopsy needle, the inner tube comprising an inner tube having an interior cavity; an elastically collapsible leg having a distal section, a proximal section and a middle section and the elastically collapsible leg configured to deform to a collapsed position by a forward movement of the proximal section of the collapsible leg within an interior cavity of the biopsy needle. In some embodiments, the elastically collapsible leg is further configured to deform to the collapsed position by the forward movement of the proximal section of the collapsible leg and by a restrained movement or lack of movement of the distal section of the collapsible leg. In some embodiments, the elastically collapsible leg is formed from an elgiloy or from a super elastic material. In some embodiments, the elastically collapsible leg further comprises a cutting edge. In some embodiments, the interior cavity of the outer cannula is defined by an interior cavity wall, the elastically collapsible leg further comprises a cutting edge and the collapsed position of the elastically collapsible leg positions the cutting edge across a portion of the interior cavity of the inner tube and against a portion of the interior cavity wall of the inner tube. In some embodiments, the elastically collapsible leg is coupled to a distal portion of the inner tube and a distal portion of the biopsy needle. In some embodiments, the elastically collapsible leg is coupled to the inner tube with a weld.

Another example embodiment of present invention provides a tissue removal assembly comprising an outer cannula, an inner tube slidably received in the outer cannula, a holder assembly configured to provide a forward force on the inner tube and a restraining force on the outer cannula and a collapsible section coupled to the inner tube and the outer cannula whereby the forward force on the inner tube and the restraining force on the outer cannula collapses the collapsible section into a collapsed position. In some embodiments, the collapsible section is coupled to the inner tube with a weld. In some embodiments the outer cannula further comprises a proximal portion coupled to an outer cannula cam to receive the restraining force, the inner tube further comprises a proximal portion coupled to an inner tube cam to receive the forward force and the holder assembly comprising a force element configured to automatically provide the forward force to the inner tube cam. In some embodiments, the tissue removal assembly further comprises a cocking element configured to receive a cocking force and return the needle assembly to a ready configuration, a plunger slidably received in the inner tube and the plunger dimensioned to have a length whereby the plunger expels a tissue in the inner tube when the needle assembly is in the ready configuration. In some embodiments the outer cannula further comprises a proximal portion coupled to an outer cannula cam to receive the restraining force, the inner tube further comprises a proximal portion coupled to an inner tube cam to receive the forward force and the forward force is a manually applied force. In some embodiments, the tissue removal assembly further comprises a plunger slidably received in the inner tube and

4

the plunger dimensioned to have a length whereby the plunger can be received in a majority of the inner tube and expel a tissue.

Another example embodiment of present invention provides a method of tissue removal comprising the steps of positioning a needle assembly in a tissue, engaging a tissue portion, and withdrawing the tissue portion from the tissue. In some embodiments the step of engaging a tissue portion further comprises, applying a forward force to the inner tube, applying a retrograde force to the outer cannula and collapsing a collapsible section whereby the collapsible section engages the tissue portion in an inner tube. In some embodiments, the step of withdrawing the tissue portion further comprises withdrawing the needle assembly from the tissue, applying a retrograde force on the collapsible section, disengaging the tissue portion and removing the tissue portion from the needle assembly. In some embodiments, the step of removing the tissue portion from the needle assembly comprises receiving a plunger in a portion of the inner tube expelling the tissue portion. In some embodiments, the method of further comprises reconfiguring the needle assembly into a ready configuration.

Other embodiments, objects, advantages and benefits are accomplished according to the devices, assemblies and methods described herein.

#### BRIEF DESCRIPTION OF THE SEVERAL VIEWS OF THE DRAWINGS

In order that the manner in which the above-recited and other advantages and features of the invention are obtained, a more particular description of the invention briefly described above will be rendered by reference to specific example embodiments thereof which are illustrated in the appended drawings. Understanding that these drawings depict only typical embodiments of the invention and are not therefore to be considered to be limiting of its scope, the invention will be described and explained with additional specificity and detail through the use of the accompanying drawings in which:

FIG. 1 is a perspective illustration of one embodiment of a tissue removal apparatus;

FIGS. 2A-2D are multiple perspective illustrations of one embodiment of the components of a needle assembly;

FIGS. 3A-3C illustrate of one embodiment of a inner tube showing different perspective views of the collapsible section in a collapsed position;

FIG. 4 is a perspective illustration of one embodiment of a tissue removal apparatus with the holder assembly partially exposing elements of the holder assembly;

FIG. 5A is a perspective illustration of an alternative embodiment of an inner tube;

FIG. 5B is a perspective illustration of an alternative embodiment of an inner tube showing the collapsible section in a collapsed position;

FIG. 6A is a perspective illustration of an alternative embodiment of an inner tube;

FIG. 6B is a perspective illustration of an alternative embodiment of an inner tube showing the collapsible section in a collapsed position;

FIG. 7A is a side cut-away view of one embodiment of a needle assembly with the collapsible section in a neutral position;

FIG. 7B is a side cut-away view of the embodiment of FIG. 7A with the collapsible section in a collapsed position;

FIG. 7C is a top view of one embodiment of a collapsible section;

5

FIG. 7D is a side view of the embodiment of the collapsible section of FIG. 7C;

FIG. 8A is a top perspective view of one embodiment of an outer cannula and a slide;

FIG. 8B is a top perspective view of one embodiment of an inner tube and an inner tube handle;

FIG. 8C is a top perspective view of one embodiment of a plunger and a plunger handle;

FIG. 8D is a top perspective view of one embodiment of a needle assembly with the plunger received in an inner tube and the inner tube received in the outer cannula;

FIG. 9A is a top perspective view of one embodiment of a latch;

FIG. 9B is a top perspective view of one embodiment of a latch received in the slide guide;

FIG. 10A is a top perspective view of one embodiment of a tissue removal apparatus;

FIG. 10B is a top perspective view of one embodiment of a tissue removal apparatus with the top removed; and

FIG. 11 is a process diagram illustrating the steps for one embodiment of methods for tissue removal.

#### DETAILED DESCRIPTION OF THE INVENTION

Methods and apparatus for tissue removal will now be described in detail with reference to the accompanying drawings. It will be appreciated that, while the following description illustrates methods and an apparatus that removes tissue samples from the human body, the systems and methods disclosed herein have wide applicability. Notwithstanding the specific example embodiments set forth below, all such variations and modifications that would be envisioned by one of ordinary skill in the art are intended to fall within the scope of this disclosure.

One Embodiment of the Tissue Removal Apparatus:

As shown in FIG. 1, one embodiment of the tissue removal apparatus 100 generally comprises a needle assembly 120 and a holder assembly 160.

In one example embodiment, the needle assembly 120 generally comprises an inner tube, an outer tube having an interior cavity with a diameter to slidably receive the inner tube and a collapsible section operably engaged with the inner tube and the outer cannula whereby a forward movement of a portion of the inner tube within the interior cavity of the outer cannula changes the collapsible section from a neutral position to a collapsed position.

The inner tube, a substantially tubular part, also called a cannula or inner cannula, has an interior cavity and a distal portion with a distal end configured to penetrate a tissue. The outer cannula or outer tube may be constructed from a single piece or it may be constructed using multiple parts such as the distal end having a cutting edge being welded to a second tube. In some embodiments, the second tube may have a slightly larger inside diameter (ID) to create a stepped edge if necessary. Slidably disposed within the outer cannula is a second substantially tubular part, also called a tube or an inner tube, having an interior to receive a portion of tissue when the tissue is penetrated by the outer cannula and the inner tube. The inner tube may be constructed from a single piece of material or it may be constructed from multiple parts such as a pusher tube from a proximal end towards a distal portion with a distal end.

In some embodiments, the needle assembly also comprises a collapsible section configured to separate a tissue portion received in the inner tube when the tissue is penetrated by the cannula. In one embodiment, the collapsible section is part of the inner tube comprising a short length of elastic material, at

6

its distal portion with the section configured to create the collapsible section. In one embodiment, the collapsible section has a projecting section configured to move into the inner tube interior when the collapsible section changes from a neutral position to a collapsed position whereby the projection section may engage a portion of the tissue portion inserted through the proximal end of the inner tube and in the interior cavity of the inner tube.

Referring again to FIG. 1, the tissue removal apparatus may include a holder assembly 160. The holder assembly 160 provides a place for the user to grip the apparatus and maneuver the needle assembly 120 like a handle. The holder assembly may also include elements to interoperate with the needle assembly such as having a trigger mechanism providing a means to trigger the needle assembly and elements to provide a means to separate the tissue portion from the tissue.

This embodiment of the needle assembly also includes a trocar needle which can be received and held in the inner tube interior.

As described below, the apparatus may also include a cocking mechanism to cock the trigger mechanism and the apparatus may also include elements to remove the tissue portion from the interior of the inner tube when needed.

Having described the general functions of one embodiment of a tissue removal apparatus, for further illustration purposes and not for limitation, one embodiment of the needle assembly will be described in more detail with reference to FIGS. 2A-6B.

As shown in FIG. 2A, one embodiment of a tissue removal apparatus comprises a needle assembly where the needle assembly 220 comprises an outer cannula 230, an inner tube 240 and a collapsible section to separate a tissue portion. Shown in FIGS. 2A and 2D is an optional trocar needle 228.

Detailed in the embodiment of FIG. 2B (showing interior and exterior edges), the outer cannula 230 extends from a proximal or head portion 232 to a distal portion 234. The head portion 232 of the outer cannula is shaped to interoperate with other apparatus elements such as a holder assembly. The end of the outer cannula distal portion 234 can be of any shape, but may be sharpened with a cutting edge or otherwise shaped to assist in penetrating the tissue. The interior cavity of the outer cannula is defined by interior cavity walls. This embodiment of the outer cannula also incorporates a sharp edge, here a castellated cutting edge 236 at its distal end to assist the outer cannula 230 penetrating the tissue. In this embodiment, the outer cannula 230 has an interior shaped to retain the inner tube and a more restricted, smaller, inner diameter located proximal to the distal end such that the distal end of the inner tube will restrict the movement of the inner tube by engaging the inner tube's outer diameter. In one embodiment, the restricted inner diameter or smaller diameter portion defines an inner step 238 to restrict further distal movement of the distal end of the inner tube and a distal section of the collapsible section. The outer cannula 230 can be made from any rigid surgical material such as but not limited to stainless steel. Dimensions of the outer cannula 230 can be any dimension based on the user's preference or on the type of procedure that the assembly will be used for. Suitable sizes by gauge size and inside diameter (ID) and outside diameter (OD) typically include but are not limited to 11 gauge [(0.120" OD×0.100" ID), (3.048 mm OD×2.54 mm ID)], 12 gauge [(0.109" OD×0.091" ID), (2.769 mm OD×2.311 mm ID)], 14 gauge [(0.083" OD×0.072" ID), (2.108 mm OD×1.829 mm ID)], 16 gauge [(0.065" OD×0.055" ID), (1.651 mm OD×1.397 mm ID)], 18 gauge [(0.050" OD×0.042" ID), (1.27 mm OD×1.067 mm ID)] and 20 gauge [(0.028" OD×0.020" ID), (0.711 mm OD×0.508 mm ID)].



The lengths of the outer cannula **230** depend on size and application but example embodiments include lengths of about 10 cm, 15 cm, 20 cm and 25 cm. Although the above embodiment has a stepped interior diameter restrict the movement of the inner tube, other embodiments may use other elements to restrict the movement such as ridges, notches, ribs, welds or any other type of protrusions or restrictions to effectively reduce the inner diameter of the cannula at that point.

Detailed in FIG. **2C**, one embodiment of the inner tube **240** is a thin wall cannula or tube with a super elastic or elastic collapsible section **250** that has a bias to collapse in a pre-defined manner. The collapsible section **250** is positioned near the end of the distal portion **244** of the inner tube **240**. The collapsible section **250** may be defined by a cut configuration of partially removed inner tube wall portions **252** such that a non-removed wall portion (connecting section **254**) forms a strip of material that will deflect into a projecting section (shown in FIGS. **3A-3C**), such as in a knee like shape, when some pressure is applied to it and then return to its original shape once the compressive force is released. The inner tube **240** can be made from any elastic or superelastic surgical material including, but not limited to, metals, metal alloys such as nickel titanium alloys known to be shape-memory metals which are sold and manufactured under the trademark "Nitinol," and rigid or semi-rigid plastics. It is also anticipated that new materials, as they are developed, will be useful such as but not limited to egiloy. The inner tube is sized to fit within the inside diameter for the outer cannula yet still have a suitably sized interior to receive tissue portions. Examples of suitable lengths for the inner tube include lengths similar to those of the outer cannula listed above and outside diameters slightly smaller than the inside diameter of the outer cannula (excluding the stepped diameter). The inside and outside diameter of the inner tube **240** is a function of the gauge size with a wall thickness of between 0.002 to 0.0035 inches (0.0508 to 0.089 mm). Suitable sizes by gauge size include but are not limited to 11 gauge [(0.099" (inches) OD×0.093" ID), (2.525 mm OD×2.362 mm ID)], 12 gauge [(0.090" OD×0.084" ID), (2.286 mm OD×2.133 mm ID)], 14 gauge [(0.071" OD×0.065" ID), (1.803 mm OD×1.651 mm ID)], 16 gauge [(0.054" OD×0.050" ID), (1.372 mm OD×1.27 mm ID)], 18 gauge [(0.041" OD×0.038" ID), (1.041 mm OD×0.965 mm ID)] and 20 gauge [(0.027" OD×0.023" ID), (0.6858 mm OD×0.584 mm ID)].

The collapsible section **250** possesses characteristics of being able to bend, deform or otherwise collapse in deflection from a neutral position to a collapsed position but will return to its original neutral position shape without taking a set. In its normal, neutral position prior to firing or collapsing, but in a ready state, the inner tube and the collapsible section **250** has a generally full round inside diameter allowing the outer cannula and the inner tube to pass over a trocar needle which may be the inner most member of the needle assembly and the trocar may be stationary relative to the cannula and the inner tube.

The modification of the inner tube walls by cutting specific shapes and the alignment of those shapes may create an interaction of the shapes with the tissue portion to engage or sever and hold the portion in place until such time as it can be removed by reversing the process. Cutting may be made by methods such as etching, laser cutting, chemical cutting, water jet cutting or machining. The cutting may be made directly to a tube or the cutting may be made to a sheet of elastic material where that sheet will later be welded or otherwise shaped into a tube.

Other enhancements can be made to the collapsible section **250** to bias the collapse. For example, the walls of the tube may be etched, cut or machined to create points, like inflection points, where the material and the tube is more likely to bend. Methods of creating these points may be with the use of etching such as laser or chemical etching or cutting away a certain thickness of the using through such means as laser cutting, chemical cutting, water jet cutting or machining.

In addition to cutting or etching to add characteristics to the inner tube, methods similar to those described in U.S. Patent Pub. No. US2010/0106093 to McGluckin et al., published Apr. 29, 2010, which is herein incorporated by reference in its entirety, can be used. For example, bends can be formed in the Nitinol tube by either deforming the inner tube under extreme heat for a prescribed period of time or by cold working the inner tube by applying mechanical stress to deflect the inner tube.

Referring back to the embodiment of FIG. **2C**, the collapsible section **250** is defined by the section of the tube having a connecting section **254** and a removed portion **252** of the tube wall. The connecting section **254** of the tube wall comprises a middle or projecting section **255**, a distal section **256** and a proximal section **257**. In this embodiment, the connecting section **254** is created by removing a portion of the inner tube wall. The size of the removed portion **252** can be any size to increase the tendency for the connecting section **254** to bend when a force is placed on either end portions of the inner tube. Consistent with the example shown, the removed portion can be any size that still allows a portion of the width of the connecting section to define a projecting section **255** that can engage the tissue portion in the tube interior and pull the portion when the needle assembly is removed from the tissue. A suitable range of dimensions for the width (or partial outside circumference) of the projecting section **255** is about forty (40) to eighty (80) percent of the inside diameter of the tube with a preferable dimension of about fifty (50) to sixty (60) percent of the ID. This width may be provided by a single projecting section or it may be provided by the cooperation of multiple projecting sections. The overall length of the collapsible section varies with the gauge size of the tube. The profile length can be any suitable length, with lengths from 0.120 inches (3.048 mm) for a 20 gauge to 0.300 inches (7.6199 mm) for an 11 gauge tube as suitable examples. If a Nitinol segment of the inner tube **240** is used to provide the features of the collapsible section, the Nitinol segment will vary according to the gauge size. One example embodiment of the Nitinol segment may be typically in the range of 0.150 to 0.500 inches (3.810 to 12.7 mm) long.

Although embodiments of the collapsible section **250** include those that are integral to the inner tube, it is also understood that the collapsible section **250** may be a separate element coupled to the inner tube or it may be a separate element that is dimensioned so that it interoperates within the outer cannula and the inner tube and provide the functional features as if it were integral to the inner tube. For example, the collapsible section **250** may be a separate, short tube with OD and ID similar to the inner tube and removed portions providing the bias to collapse and this collapsible section fits between the stop of the outer cannula and inner tube so that forces on the inner tube are translated to the collapsible section and it collapses.

As operationally described below, the needle assembly may further include other elements to interoperate with the collapsible section. In this embodiment, the inner tube and the outer cannula interoperate to help separate the tissue portion. As shown in FIGS. **2B** and **2C**, the outer cannula **240** has a stepped insider diameter **238** smaller than the OD of the inner

tube **240** so that it retains or restricts the inner tube **240** and prevents it from moving out of the distal end of the outer cannula **230**. When a force is put on the proximal portion **242** of the inner tube, because the distal portion **244** cannot move due to the step **238**, this force is translated to urge the collapsible section **250** to collapse to a collapsed position.

FIG. **3A** illustrates the collapse of the collapsible section within the outer cannula **330**. FIGS. **3B-3C** show different views of a collapsed collapsible section **350** outside of the inner tube. As shown in FIG. **3C**, when the collapsible section **350** collapses, the projecting sections **355A** and **355B** are urged and displaced into the interior of the inner tube **340** engaging whatever material may be in the inner tube at the time, such as a tissue portion. The projecting sections **355A** and **355B** may sever the tissue portion or it may frictionally engage the tissue portion so that it can be severed by movement of the inner tube **340** and collapsible section **350** such as through withdrawal of the needle assembly from the tissue. As shown, the two offset projecting sections **355A** and **355B** form an “S” shaped constriction within the interior of the inner tube **340**. For embodiments that include a trocar needle, the trocar needle is usually positioned well distal to the collapsible section **350** when a tissue portion is to be placed into the cavity of the inner tube **340**.

As described above, the collapsible section **350** can be enhanced with attributes to further promote the collapsing of the collapsible section **350**. For example and not for limitation, inflection points may be etched or cut into the wall of the inner tube **340** to help bias the projection of the projecting sections. Suitable inflection points for the configuration shown in FIG. **3C** would include etchings or cuts made on the inside of the wall of the inner tube **340** at either end of the projecting section **355** and an etching or cut made on the outside of the inner tube wall at the center so that the projecting sections **355A** and **355B** create a “knee” like protrusion. Other configurations of etching or partial cutting of the inner tube **340** to enhance its collapse are also suitable. As described above, the inflection points may be made directly to the inner tube or they may be made on material that will be later shaped to create the inner tube **340**.

An example embodiment of a needle assembly in a tissue removal apparatus is shown in FIG. **4**. In this embodiment, the apparatus **400** integrates the needle assembly **420** with a holder assembly **460** and a trocar needle **428**.

Referring to the example embodiment of FIG. **2A**, the trocar needle **228** may be a rigid elongated rod positioned within the inner tube as the inner most member of the needle assembly. The trocar needle **228** may be used with the holder assembly to position the distal end of the needle assembly near the tissue to be removed. As detailed in FIG. **2D**, preferably, the trocar **228** has a cutting or sharpened tip **229** to ease positioning of the apparatus and can be secured to the holder assembly so that the user can manipulate the trocar needle and the needle assembly with the holder assembly. In the embodiment shown in FIG. **4**, the trocar needle **428** is stationary relative to the holder assembly **460** as opposed to the inner tube and outer cannula that are able to move relative to the holder assembly **460**.

As shown in FIG. **4**, this embodiment of the holder assembly **460** includes a trigger mechanism and elements to assist separating the tissue portion. The trigger mechanism comprises a force element interoperating with the outer cannula and inner tube of the needle assembly **420**. The force element axially displaces the cannula and inner tube in a distal direction relative to the holder assembly and may also be structured and arranged for substantially consecutive axial displacement of the cannula and the inner tube in combination,

and of the inner tube only. In an example embodiment, as shown in the holder assembly **460A**, which is a blown up partial view of holder assembly **460**, the force element has a first and second force element. In the embodiment shown, the first force element comprises a first spring **461**. This force element operationally engages a first cam **462** coupled to the outer cannula. The first spring **461** engaging the first cam **462** displaces both the outer cannula **430** and the inner tube (within the cannula) by engaging their proximal ends or other proximal portions. A second force is provided that displaces the proximal portion of the inner tube. In this embodiment, the second force is applied to the inner tube by the momentum of the inner tube and the inner tube cam **463** as they are advanced with the outer cannula **430** by the first force element. This momentum urges the inner tube to advance even as the movement is restricted by the distal portion of the outer cannula **430**. The displacement of the inner tube proximal or head portion by the second force only enables the proximal portion of the inner tube (pusher section) to be displaced, and with the distal portion of the inner tube restricted, it causes the collapsible section of the inner tube to collapse within the inner tube cavity. When a portion of tissue is within the inner tube cavity beyond the collapsible section (towards the head end), that portion of tissue is engaged by the projecting section so that it can be separated from the rest of the tissue and held within the inner tube so that it can be withdrawn from the rest of the tissue. Also shown is a buffer spring **464** to buffer the movement of the inner cannula relative to the outer cannula which may also provide a retrograde force on the inner cannula cam.

In this embodiment, the trocar needle **428** is coupled to the housing of the holder assembly **460A**. The trocar needle **428** does not move relative to the holder assembly **460**, but the outer cannula and inner tube may be moved relative to the trocar needle **460**.

The second force above may be any force to displace the proximal portion of the inner tube when the outer cannula stops advancing and may interoperate with other apparatus elements to retain the collapsible section in a collapsed position. One suitable force is the inertia of the inner tube and inner tube cam to collapse the collapsible section where it will engage the tissue portion, rebound (not collapsed) and friction with the tube inner walls hold the tissue in place until the tissue portion is pushed out. Another example of a suitable force is a manually applied force to the inner tube or the inner tube cam. Embodiments may also include a latching mechanism to engage the tube once the tube advances to a point where it has collapsed the collapsible section and the latching mechanism holds the inner tube in position until it is unlatched when the assembly pushes out the tissue portion. Other embodiments may include a push rod or plunger activated by the cannula stopper and pushing the tube forward and held in place by a spring until the assembly pushes out the tissue portion.

The holder assembly **460** may also include a cocking mechanism and a removal mechanism to remove the tissue portion from the interior cavity of the inner tube. In this embodiment, the cocking mechanism may comprise a cocking handle **468** that operates to pull back the extended outer cannula cam **462** back to engage a latch **470** and retain the needle assembly **420** in the ready configuration for reuse. The removal mechanism in this embodiment is provided by the trocar needle **428** that maintains its position in relation to the holder assembly **460** while the needle assembly **420** is cocked and therefore pushes any tissue portion out of the inner cannula.

## 11

Other embodiments of collapsible sections of the inner tube are shown in FIGS. 5A-6B.

FIG. 5A illustrates a needle assembly embodiment having a collapsible section 550 with a single projecting section 555 such as a collapsible leg. FIG. 5B illustrates how the projecting section 555 advances into the interior cavity of the inner tube 540 when collapsed.

FIG. 6A illustrates a needle assembly embodiment having a collapsible section 650 with two, generally symmetric projecting sections 655 on opposite sides of the walls of the inner tube 640. FIG. 6B illustrates how the projecting sections 655 advance into the interior cavity of the inner tube 640 when collapsed.

FIGS. 7A and 7B illustrate example embodiments of a needle assembly 720. In this embodiment, the needle assembly 720 comprises an inner tube 740, an outer cannula 730 and a collapsible section 750. In this embodiment, the inner tube 740 may be used with an outer cannula 730 that may be a biopsy needle. The outer cannula 730, comprises a tube having a proximal/head portion and proximal/head end, a distal portion and distal end which may be sharpened, and an interior cavity dimensioned to receive the inner tube and collapsible section. The inner tube comprises an inner tube having an interior cavity, a distal portion and a proximal portion. The collapsible section 750 comprises a distal section 756, a proximal section 757 and a middle section 755 and the collapsible section is configured to deform to a collapsed position by a forward movement of the proximal section of the collapsible leg within an interior cavity of the biopsy needle. In this embodiment, the collapsible section is coupled to the distal portion of the inner tube 740 and the distal portion of the outer cannula 730. In this embodiment, the collapsible section 750 comprises a collapsible leg which may be an elastically collapsible leg.

The collapsible section 750 may be made from any material that allows the section to collapse or deform. In embodiments, the collapsible section 750 is made from elastic material such as, but not limited to super elastic materials as described above including elgiloy. One embodiment of elgiloy is a Co—Cr—Ni Alloy consisting of 39-41% Cobalt, 19-21% Chromium, 14-16% Nickel, 11.3-20.5% Iron, 6-8% Molybdenum, and 1.5-2.5% Manganese. Elgiloy is a beneficial material because some embodiments are corrosion resistant and exhibit high strength, ductility, and good fatigue life.

As illustrated here, and more particularly in FIGS. 7C and 7D, the collapsible section 750 may be a single leg shaped as a generally flat elongated strip. FIG. 7C illustrates a top view of one embodiment of the collapsible section 750 which may include a pair of notches 758 narrowing the width of the collapsible section 750 at any particular point. A flat elongated strip shape of the collapsible section 750 enables the section to be more easily collapsed and provides for a more firm engagement of the section with the outer cannula when engaging the tissue portion. The flat shape of leg may be more easily collapsed than a leg made from a cut out of a tube because the curve of the wall of the inner tube may provide more resistance to collapsing. The notches 758 or other manufacturing means such as cutting, etching or scoring may provide characteristics to further promote collapsing. Having a separate collapsible section 750 coupled to the inner tube 740 and the outer cannula 730 also allows the needle assembly 720 to be made from less expensive materials than would be required by having the collapsible section be integral to the other elements which may require the entire inner tube or outer cannula, or portions of them, to be manufactured from elastic or super elastic materials that may be more expensive and may require different manufacturing processes to create.

## 12

Having the collapsible section 750 coupled, rather than integral to either of the tubes, also allows the collapsible section 750 to be welded or otherwise coupled to the inner tube and/or the outer cannula. In some embodiments, a welded coupling, shown here as weld 757W and weld 756W, to the tubes helps the collapsible section more easily maintain the beneficial properties of the generally flat shape.

In this embodiment, the collapsible section 750 is coupled to the exterior wall of the inner tube 740 with the weld 757W such that a forward movement of the inner tube urges the proximal section of the collapsible section 750 to move forward. The coupling may be provided by a direct attachment, connection, attachment with an intermediary element or it may be provided by other means such as being integral to the inner tube, having an intermediate element between the leg and inner tube or having the leg simply rest against the inner tube. Coupling may also be provided by any type of connection such as, but not limited to adhesives, welding, rivets or mating connections.

As shown in FIG. 7B, the coupling is such that when the distal section of the collapsible section 750 is constrained or otherwise restricted to move less than its proximal section, a projecting section, here the middle section 755 of the collapsible section 750, is urged into and across a portion of the interior cavity of the inner tube 740 or the outer cannula 730 interior cavity so that the collapsible section 750 can engage a portion of the tissue portion inserted through the proximal end of the inner tube 740 and/or outer tube needle 730 and into the tubes interior. As described above, the middle section 755 is a projecting section that projects into the inner cavity of the outer cannula and/or the inner tube and positions the projecting section across a portion of the interior cavity of the outer cannula and proximal to a portion of the interior cavity wall of the outer cannula. As shown, the projecting section, here the middle section 755 of the collapsible section 750 may be configured to further comprise a cutting edge 755C to engage or otherwise assist in the retaining of the tissue portion in the needle assembly.

In the embodiment shown in FIGS. 7A and 7B, the collapsible section 750 may also be coupled to a portion of the outer cannula 730. In this embodiment, the distal section 756 of the collapsible section 750 is coupled to the distal portion of the outer cannula 730 by a weld 756W. This coupling provides the restriction of the collapsible leg's distal section so that when the inner tube and the proximal section of the collapsible section 750 is urged forward but the distal section of the collapsible section 750 is restricted, the middle section 755, or projecting section, is urged into the interior of the outer cannula 730. With this embodiment, when a tissue portion is received into the interior of the inner tube 740 and the outer cannula 730, the projecting section 755 frictionally engages the tissue portion by a force against the interior cavity walls of the inner tube 740 or outer cannula 730. The engagement may sever the tissue portion or the engagement may be maintained such that when a retrograde force is applied to the needle assembly 720, the projection section 755 retains the tissue in the interior of the inner tube 740 and sheers or otherwise cuts the tissue portion from the rest of the tissue.

Also shown in FIG. 7A are example dimensions of one embodiment of the needle assembly 720 elements for illustration purposes only and are not for limitation. The dimensions may be any suitable dimensions to provide the features described herein and are expected to be varied based on the application of the needle assembly. In the example shown, the collapsible section 750 is about 0.510 inches (12.954 mm) long, a distance between the coupling (757W and 756W) of the collapsible section 750 to the outer cannula 730 and the

inner tube **740** is about 0.435 inches (11.049 mm), a gap between the distal end of the inner tube **740** and a middle section **755** of the collapsible section **750** is about 0.18 inches (4.572 mm), a distance from a distal edge of the collapsible section **750** and a distal edge of an opening of the distal end of the outer cannula is about 0.04 inches (1.016 mm) and a distance from the distal edge of the opening of the outer cannula **730** to the distal end of the inner tube **740** is about 0.395 inches (10.033 mm).

Referring to FIG. 7C, showing a top view of one embodiment of the collapsible section and illustrating, for example only, example dimensions of the collapsible section **750** the length may be about 0.510 inches (12.954 mm), a width may be about 0.045 inches (1.143 mm), a length of the notch may be about 0.040 inches (1.016 mm) and a depth of the notch may be about 0.005 inches (0.127 mm). As shown in the side view of FIG. 7D, a thickness of the collapsible section **750** may be about 0.004 inches (0.102 mm).

Although the embodiment illustrated in FIGS. 7A and 7B described above has the collapsible section **750** coupled to the inner tube **740** and outer cannula **730**, other embodiments are anticipated that provide the same functions. For example, and not for limitation, it is anticipated that the inner tube may comprise multiple inner tube sections that are coupled by the collapsible section; the collapsible section may be integrated into a portion of the inner tube; or the collapsible section may contain a portion, such as a tubular portion, at its distal end that engages a portion of the outer cannula and restricts movement of the collapsible section while a proximal section engages the inner tube to receive the forward force. It is also anticipated that the collapsible section may be welded to the interior wall of the inner tube.

Although the above example embodiments describe the projecting section of the collapsible section being the middle section, it is also contemplated that the projecting section may be positioned in other sections of the collapsible section. For example, the projecting section may be placed closer to the distal section of the collapsible section. Configuring the projecting section in different places on the collapsible section may be done by placing notches, etchings or other similar characteristics in particular sections to promote the collapsing of the collapsible section at a particular location.

FIGS. 8A-8D illustrate an example embodiment of the needle assembly of FIGS. 7A and 7B further comprising a plunger. FIG. 8A illustrates an embodiment of the outer cannula **830** with a cam **862** coupled to its proximal portion or proximal end. The cam **863** may be configured to receive the restraining force and transfer it to the outer cannula. FIG. 8B illustrates an embodiment of the inner tube **840** with an inner tube cam **863**, here a handle, on a proximal portion or proximal end. The inner tube may be coupled to the inner tube cam to receive the forward force and transfer that to the inner tube **840**. FIG. 8C illustrates an embodiment of the plunger **828** with a plunger handle **827**.

As shown in FIG. 8D, the plunger **828** is slidably received in the inner tube **840**. Both the inner tube **840** and the plunger **828** may then be received in the outer cannula **830**. The plunger **828** is dimensioned to be able to extend through a majority of the inner tube **840** so that it may expel or otherwise push out any tissue or tissue portion that may be in the inner tube **840**. The inner tube **840** is dimensioned to extend through the outer cannula **830** to a point where the collapsible section (not shown) can collapse and engage the tissue. The outer cannula **830** is dimensioned to penetrate the tissue and interoperate with other assembly elements such as any triggers, cams, handles or a holder assembly.

FIGS. 9A and 9B illustrate other elements as part of one embodiment of a needle assembly. FIG. 9A illustrates one embodiment of a latch **970** comprising a latch key **972**, a latch extension **973** and a latch handle **971**. FIG. 9B illustrates one embodiment of a slide guide **974** to slidably receive the latch **970** and the outer cannula cam (now shown). The slide guide **974** comprises a slide channel **975**, a slide stop **976** and one or more guide keys **977**. The slide guide **974** and the guide keys **977** are configured to engage the underside of the slide when the slide is pulled towards the slide stop **976**. The guide keys **977** are also able to move in and out of the slide guide **974** by a guide key ramp (not shown) that is moved or deflected out of the slide guide **974** by the forward movement of the latch key **972** over the guide key ramp. As illustrated, the guide keys **977** and the guide key ramp are a cut out portion of the slide guide **975** so that they can be used to hold the slide in the ready configuration and deflect to release the slide and outer cannula by forward movement of the latch key **972** so that they can advance forward.

FIG. 10A illustrates one embodiment of tissue removal apparatus **1000**. This example embodiment of the tissue removal apparatus **1000** includes a holder assembly **1060** and a needle assembly with the outer cannula **1030** shown.

FIG. 10B illustrates a view of the tissue removal apparatus **1000** of FIG. 10A without the top. In this embodiment, the needle assembly is similar to the embodiments of FIGS. 8A and 8B with the inner tube, the outer cannula **1030** and the collapsible section. The inner tube (received in outer cannula) has an inner tube handle **1065** as a cam and the outer cannula **1030** has an outer cannula slide **1062** as a cam. This embodiment also has a plunger **1028** with a plunger handle **1027**. Also shown is an example embodiment of a trigger mechanism and a cocking mechanism. In this embodiment, the trigger mechanism comprises the guide, the latch, the latch handle **1071**, latch key, the guide keys, the guide key ramp and force elements that operationally engage the inner tube cam and the outer cannula slide **1062** to change the collapsible section to its collapsed position. The trigger mechanism may be configured to automatically provide the forward force to the inner tube or inner tube cam **1065**. This trigger mechanism may also provide a forward force to advance the outer cannula **1030** into the tissue. As shown, a first force element **1061**, here a spring, rests against and engages the outer cannula slide **1062**. The outer cannula slide **1062** is coupled to the outer cannula **1030** so that it functions as a cam to move the outer cannula **1030**. The first force element **1061** is constrained between the slide stop **1076** of the slide guide and the slide **1062** so that it provides a forward force on the slide **1062** and outer cannula **1030**. The slide **1062** is retained in a position by the guide keys of the guide engaging the underside of the slide **1062** such that it compresses the first force element **1061**. When the latch key is moved forward by the latch handle **1071**, such as applying a forward force, it pushed the latch key against the guide key ramp, deflecting the guide keys out of the guide and out of engagement with the underside of the slide **1062**, such that it releases the slide **1062** and the first force element **1061** which then advances the slide **1062** and the outer cannula **1030** within the slide guide. The slide **1062** and the outer cannula **1030** advance to a position until the slide **1062** can no longer move within the guide. The slide **1062** and the outer cannula **1030** may be kept in that advanced position by the force of the first force element **1061** or by other mechanical means. Through this advancing of the outer cannula **1030**, in some embodiments, the latch and the inner tube is also advanced. This is because in those embodi-

ments, the inner tube **1040** is coupled to the outer cannula **1030** by the collapsible section (not shown) and the latch is engaged with the slide **1062**.

The holder assembly **1060** may be configured to provide a forward force on the inner tube and a restraining force on the outer cannula **1030** whereby when the collapsible section is coupled to the inner tube and the outer cannula **1030**, the forward force on the inner tube and the proximal section of the collapsible section and the restraining force on the outer cannula **1030** causes a restrained movement of the distal section of the collapsible section relative to the proximal section of the collapsible section and may collapse the collapsible section into a collapsed position. The restrained movement may also be a lack of movement. In the embodiment of FIG. **10B**, when the inner tube and the outer cannula **1030** are in the advanced position, the inner tube may be further advanced by providing a forward force to advance the inner tube. The forward force may be a manual or spring force on the inner tube cam, here the inner tube handle **1065**. The forward force may also be provided by the momentum of the inner tube and inner tube handle **1065** as they move forward with the outer cannula **1030**. When outer cannula **1030** is restrained by the slide **1062** and the slide guide, the restraining force is applied to the outer cannula **1030**. Together, the forward and restraining forces collapse the collapsible section into the collapsed position and the collapsible section engages the tissue portion within the needle assembly so that when the needle assembly is withdrawn from the tissue, the tissue portion is withdrawn in the needle assembly. In the embodiment of FIG. **10B**, the inner tube handle **1065** functions as the inner tube cam and spring **1064** functions as a buffer spring to counter some of the momentum of the inner tube and inner tube cam as they move forward with the outer cannula **1030**.

In this example embodiment, the plunger **1028** may be used to expel the tissue portion from the needle assembly. As shown, the plunger **1028** may be configured so that advancing it by putting a forward force on the plunger handle **1027** causes the plunger **1028** to advance and extend through the inner tube and push the tissue portion out of the distal end of the inner tube and outer cannula **1030**.

Although this illustrated embodiment has a trigger mechanism to provide the forward forces on needle assembly elements, it is understood that the elements may also be triggered by manual forces. For example, the outer cannula may be positioned in the tissue by manually manipulating the holder assembly and outer cannula. Also, the inner tube and collapsible section may be triggered by manually providing a forward force on the inner tube or the inner tube cam and advancing it relative to the outer tube which may be restrained mechanically or manually.

FIG. **10B** also illustrates an embodiment of a cocking mechanism to allow for reuse of the tissue removal apparatus **1000** and the needle assembly. The cocking mechanism may comprise the interoperation of elements such as the latch handle **1071**, the outer cannula **1030**, the inner tube (received in the outer cannula), the slide **1062** and the latch key. In this embodiment, the cocking mechanism is configured such that when the apparatus is in the advanced position as shown, pulling the latch handle **1071** will put a retrograde force on the inner tube and the outer cannula **1030**. The retrograde force pulls the needle assembly back until the slide **1062** is engaged with the guide key. The guide key again retains the inner tube, the collapsible section and the outer cannula **1030** in the ready configuration for reuse.

Also shown in FIG. **10A** are a holder assembly **1060**, holder grips **1067**, a channel tower **1068** and channels for the

inner tube handle, the latch handle **1069A** and a separate channel for the plunger handle **1069B**.

Other embodiments of the inner tube comprise the inner tube having a body portion separated from a fore portion of the inner tube and the elastically collapsible leg is coupled to both the fore portion and the body portion of the inner tube. In this embodiment, the collapsible leg may be coupled to the fore portion of the inner tube by a first weld and the collapsible leg may be coupled to the body portion by a second weld.

Other embodiments of the needle assembly comprise at least one additional collapsible section such as an additional collapsible leg.

Other embodiments of the collapsible section are also envisioned which include any mechanism to collapse a projecting section into the inner tube interior.

One Embodiment of the Tissue Removal Apparatus in Operation:

One example embodiment of methods of tissue removal are illustrated by the operation of one embodiment of the tissue removal apparatus which generally comprises the steps of positioning a needle assembly in a tissue, engaging a tissue portion and withdrawing the tissue portion from the tissue. For purposes of illustrating in more detail the operation of one embodiment of a tissue removal apparatus, and not for limitation, the operation of an apparatus for tissue biopsy is summarized in FIG. **11**. This illustration is consistent with tissue removal apparatus of FIGS. **1**, **2A-2D** and **4**.

Referring to FIG. **11**, the steps for this embodiment of the methods generally comprise the step of positioning the needle assembly in the tissue at **1180**, engaging a tissue portion of the tissue at step **1185**, withdrawing the tissue portion at **1190** and may include reconfiguring the needle assembly in the ready configuration at step **1195**.

The additional steps shown in FIG. **11** are illustrated referring to the example embodiments of the tissue removal apparatus of FIGS. **1**, **2A-2D** and **4**. The apparatus for this example is initially provided in the ready configuration which puts the needle assembly in a ready position similar to those embodiments shown in FIGS. **2A-2D** and **4**. Referring to FIGS. **2A-2D**, in a ready configuration, the needle assembly **220** is typically configured so that the trocar needle **228** is slidably positioned through both the inner tube **240** and the outer cannula **230** with the trocar needle sharpened distal end **229** protruding through the open distal end **234** of the outer cannula **230**. In this embodiment, the trocar needle distal end **229** is sharp and pointed protruding slightly to form a needle-like tip in combination with the sharp serrated distal end of the distal portion **234** of the outer cannula **230**. In the ready configuration, the collapsible section **250** is set in the neutral position so that it will actuate and change to a collapsed position when the triggering mechanism is triggered.

With this configuration, the process of operation starts with the step of positioning the distal end of the needle assembly **220**. The needle assembly **220** is positioned, using a holder assembly as a handle, through and into the tissue by the user to a point for removing a section of the tissue. In one embodiment, the needle assembly **220** is positioned so that when the outer cannula **230** and inner tube **240** are advanced by triggering the trigger mechanism, they will advance into and retain the tissue portion desired to be removed.

With the needle assembly **220** positioned, the tissue portion of the tissue is then engaged. In one general embodiment, the step of engaging a tissue portion comprises applying a forward force to the inner tube **240**, applying a retrograde force to the outer cannula **230** and collapsing the collapsible section **250** whereby the collapsible section **250** engages the tissue portion in the inner tube **240**.

Referring to FIG. 4, in one embodiment, the step of engaging a tissue starts with a holder assembly **460** having a trigger mechanism. In this embodiment, the trigger mechanism comprises a trigger button **469**, a latch **470** and force elements within the holder assembly **460**. In this embodiment, the trigger button **469** is configured such that when it is pushed or depressed, it operationally engages a latch **470** which releases a force element **461** and the outer cannula **430** and inner tube (received in the outer cannula) are advanced into and around the tissue to be removed. In this embodiment, the outer cannula **430** is released by the latch **470** and advanced by a first force element **461** comprising a first spring operationally engaging and applying a first force to a first cam **462**. In this embodiment, the trocar needle **428** is stationary in the holder assembly **460** and does not advance which lets the outer cannula **430** and inner tube advance with an empty interior portion. With this advance, the tissue portion is brought into the empty interior cavity of the inner tube. As the needle assembly **420** reaches its advancing limit, as defined by a positive stop, a second force, such as provided by the inertia of the inner tube and inner tube cam **463** (coupled to the inner tube proximal portion), continues to apply a forward force to the proximal portion of the inner tube advancing it further in a distal direction. The action of the inner tube distal portion being depressed against the stepped surface of the outer cannula **430** causes the collapsible section to collapse. Because the tissue portion is in the inner tube interior, as the collapsible section collapses, the projecting section moves into the interior of the inner tube, engaging and sometimes severing the tissue portion. In one embodiment, the offset projecting sections of the flexible Nitinol collapsible section deflect inward in an "S" like action from an hour glass like shape that has been cut in to the inner tube wall by a laser or other means in a manner to facilitate and influence this action. At a point, the collapsible section collapses no more and the proximal portion of the inner tube stops advancing. In some embodiments, the inner tube is kept in this position which maintains the projecting sections engagement of the tissue portion and the apparatus is pulled from the tissue taking with it the tissue portion. In some embodiments, the inner tube may extend back to its original, uncollapsed or neutral state and the severed tissue portion stays in the tube interior to be pulled from the tissue with the needle assembly **420** is withdrawn. In other embodiments, the knee like projecting section of the inner tube performs both the function of engaging or severing the specimen and holding the specimen in place while the needle assembly is removed.

The holder assembly **460** may also have a depth limiting stop that provides a set distance for the advancing of the outer cannula **430** into the tissue. This stop assists in providing a length of tissue portion to be withdrawn by the apparatus.

With the tissue portion engaged, the tissue portion is then withdrawn from the tissue. In one general embodiment, the step of withdrawing the tissue portion comprises withdrawing the needle assembly and the tissue portion from the tissue, applying a retrograde force on the collapsible section, disengaging the tissue portion and removing the tissue portion from the needle assembly.

To retrieve the tissue portion from the interior of the needle assembly **420** after the device is removed from the patient's tissue, the device is re-cocked in one embodiment. In some embodiments, this re-cocking simply pushes the tissue portion out of the inner tube. In other embodiments, this re-cocking relieves the forward force on the inner tube and the collapsible section allowing it to relax back into or near its normal shape of a fuller inner diameter and the tissue portion can then be removed. This cocking may be done with a handle

that retracts the inner tube and the outer cannula **430** as well as set the trigger mechanism. In this embodiment, at a set point, the inner tube, outer cannula **430** and trigger mechanism are maintained in a set, ready configuration until the trigger button **469** is pushed. Once this set point is reached, the handle can be positioned back within the holder assembly **460**. By reconfiguring the needle assembly **420** back into this ready configuration, the trigger mechanism is now ready to fire again. In one embodiment, the set point of the ready configuration, has the inner tube, outer cannula **420** and trocar tip positioned to repeat the tissue removal methods.

Operationally, as the device is being cocked, the inner tube and the outer cannula **430** are retracted back over the trocar needle **428** and the tissue portion is ejected by the action of the trocar needle **428** advancing relative to the inner tube, typically back to its ready configuration with the distal tip extending from the distal opening of the outer cannula **430**.

Although this embodiment has the trocar maintaining its position with respect to the holder assembly, other embodiments having the trocar move relative to the holder assembly are possible.

In other embodiments of the methods of tissue removal, the apparatus is initially in an uncocked configuration. In these embodiments, the apparatus is initially in an uncocked position and, similar to the cocking methods above, the apparatus can be cocked to a ready configuration by putting a cocking force on a cocking element and the needle assembly can then be put into the ready configuration to repeatedly follow the tissue removal methods described.

Another example of a needle assembly in operation may be illustrated using the example embodiments of the needle assembly and tissue removal apparatus shown in FIGS. **7A-10B**.

Referring again to the process steps shown in FIG. **11**, the tissue removal apparatus is positioned in the tissue by manipulation of the holder assembly at **1180**. This comprises providing the needle assembly configured in the ready configuration for triggering the needle assembly at **1182** and inserting the needle assembly into the tissue at **1184**. This may be done manually by inserting the needle assembly into the tissue or by triggering the trigger mechanism which applies a forward force on the needle assembly and advances the assembly into the tissue. In this example embodiment, a forward force is applied to the latch handle which advances the latch key into the guide key ramp that deflects the guide keys and releases the slide and other elements of the needle assembly. As the needle assembly advances into the tissue, the tissue portion advances into the cavity of the inner tube and outer cannula. The tissue portion is engaged at **1185**. In this embodiment, a forward force is applied to the inner tube at **1186** by applying a manual forward force to manually advance the inner tube cam. The force may also be applied automatically such as by the momentum of the inner tube and inner tube cam. A restraining force is applied to the outer cannula at **1187** by restricting the slide within the guide. These forces collapse the collapsible section at **1188** which has its proximal section welded to the distal portion of the exterior wall of the inner tube and its distal section welded to the interior of the outer cannula distal portion. The protruding section of the collapsible section engages the tissue portion with the inner tube and the outer cannula at **1189**. At this point, the tissue section may be severed in the inner tube or it may be otherwise engaged in the needle assembly. It is understood that during these steps, the collapsible section may also be maintained in the collapsed position by mechanical means or by automatically or manually applying a forward force onto the inner tube. Additionally, a retrograde force may be

19

applied to the inner tube changing the collapsed section from its collapsed position back to its neutral position. The tissue portion is withdrawn at **1190**. In this embodiment, the apparatus, the needle assembly and the tissue portion are withdrawn at **1191** by manipulating the holder assembly to pull the needle assembly out of the tissue. At **1192**, if not already done in preceding steps, a retrograde force is applied to the collapsible section. In this embodiment, this is done by applying a retrograde force on the inner tube handle and inner tube which is welded to the distal section of the collapsible section. The tissue portion is disengaged at **1193** when the collapsible section returns to its neutral position. The tissue portion may be removed at **1194** in this embodiment by advancing the plunger through the inner tube.

In one embodiment, the needle assembly may be reconfigured into the ready configuration at **1195**. This may be performed by cocking the needle assembly at **1196**. With this embodiment, the assembly is cocked by putting a cocking force on a cocking element, here applying a retrograde force to pull the latch handle until the outer cannula and the slide are restrained by engaging the latch key and the latch at **1197**. In some embodiments, the plunger may remain in one position and as the inner tube and the outer cannula are pulled back, the plunger may expel the tissue portion from the inner tube as the needle assembly moves to the ready configuration. At this point, the tissue removal assembly is in the ready configuration for possible reuse.

With respect to the above description then, it is to be realized that the optimum dimensional relationships for the parts of the invention, to include variations in size, materials, shape, form, function and manner of operation, assembly and use, are deemed readily apparent and obvious to one skilled in the art, and all equivalent relationships to those illustrated in the drawings and described in the specification are intended to be encompassed by the present invention.

Therefore, the foregoing is considered as illustrative only of the principles of the invention. Further, since numerous modifications and changes will readily occur to those skilled in the art, it is not desired to limit the invention to the exact construction and operation shown and described, and accordingly, all suitable modifications and equivalents may be resorted to, falling within the scope of the invention. Although this invention has been described in the above forms with a certain degree of particularity, it is understood that the present disclosure has been made only by way of example and numerous changes in the details of construction and combination and arrangement of parts may be resorted to without departing from the spirit and scope of the invention.

We claim:

1. A needle assembly, the needle assembly comprising: an inner tube having an interior cavity; an outer cannula having a proximal portion, a distal portion and an interior cavity; the interior cavity of the outer cannula having an interior diameter to slidably receive the inner tube; and an elastically collapsible leg operably engaged with the inner tube and the outer cannula whereby a forward movement of a portion of the inner tube within the interior cavity of the outer cannula changes the elastically collapsible leg from a neutral position to a collapsed position.
2. The needle assembly of claim 1 wherein the elastically collapsible leg is formed from an elgiloy.
3. The needle assembly of claim 1 wherein the elastically collapsible leg is formed from a super elastic material.
4. The needle assembly of claim 1 wherein the elastically collapsible leg further comprises a cutting edge.

20

5. The needle assembly of claim 1 wherein: an interior cavity wall defines the interior cavity of the outer cannula; the elastically collapsible leg further comprises a cutting edge; the collapsed position positions the cutting edge across a portion of the interior cavity of the outer cannula to a position proximal to a first side of the interior cavity wall of the outer cannula; and the collapsed position extends the elastically collapsible leg from a position proximal to a second side of the interior cavity wall of the outer cannula across a radial middle of the interior cavity of the outer cannula to the position proximal to the first side of the interior cavity of the outer cannula.

6. The needle assembly of claim 1 wherein the elastically collapsible leg is further configured to deform to the collapsed position by the forward movement of a proximal section of the elastically collapsible leg and by a lack of movement of a distal section of the elastically collapsible leg.

7. The needle assembly of claim 1 wherein the elastically collapsible leg is further configured to return to the neutral position by a rearward movement of a proximal section of the elastically collapsible leg.

8. The needle assembly of claim 1 wherein: the inner tube has a distal portion and a body portion; and the elastically collapsible leg is coupled to the distal portion and the body portion of the inner tube.

9. The needle assembly of claim 8 wherein the elastically collapsible leg is coupled to the distal portion of the inner tube by a first weld and the elastically collapsible leg is coupled to the body portion of the inner tube by a second weld.

10. The needle assembly of claim 1 wherein the elastically collapsible leg is coupled to a distal portion of the inner tube and the distal portion of the outer cannula.

11. The needle assembly of claim 10 wherein the elastically collapsible leg is coupled to the distal portion of the inner tube by a first weld and the elastically collapsible leg is coupled to the distal portion of the outer cannula by a second weld.

12. The needle assembly of claim 1 further comprising: a first cam coupled to the proximal portion of the inner tube; and a second cam coupled to the proximal portion of the outer cannula.

13. The needle assembly of claim 12 further comprising: a holder assembly comprising a first spring and a second spring; the first spring configured to provide a first force on the first cam; and the second spring configured to provide a second force on the second cam.

14. The needle assembly of claim 1 wherein the elastically collapsible leg comprises a single elastically collapsible leg.

15. The needle assembly of claim 1 further comprising a plunger slidably disposed within the interior cavity of the inner tube.

16. A needle assembly, the needle assembly comprising: an inner tube having an interior cavity; an outer cannula having a proximal portion, a distal portion and an interior cavity; the interior cavity of the outer cannula having an interior diameter to slidably receive the inner tube; an elastically collapsible leg operably engaged with the inner tube and the outer cannula whereby a forward movement of a portion of the inner tube within the

## 21

interior cavity of the outer cannula changes the elastically collapsible leg from a neutral position to a collapsed position;  
 a plunger slidably disposed within the interior cavity of the inner tube;  
 a first cam coupled to the proximal portion of the inner tube;  
 a second cam coupled to the proximal portion of the outer cannula;  
 a third cam coupled to the plunger;  
 a handle comprising a first spring and a second spring;  
 the first spring configured to provide a first force on the first cam;  
 the second spring configured to provide a second force on the second cam; and  
 the third cam configured to provide a third force on the plunger.

**17.** An inner tube for use with an outer cannula, the inner tube comprising:

an inner tube having an interior cavity;  
 an elastically collapsible leg having a distal section, a proximal section and a middle section; and  
 the elastically collapsible leg configured to deform to a collapsed position by a forward movement of the proximal section of the elastically collapsible leg within an interior cavity of the outer cannula.

**18.** The inner tube of claim **17** wherein the elastically collapsible leg is further configured to deform to the collapsed position by the forward movement of the proximal section of the elastically collapsible leg and by a lack of movement of the distal section of the elastically collapsible leg.

**19.** The inner tube of claim **17** wherein the elastically collapsible leg comprises a single elastically collapsible leg.

**20.** The inner tube of claim **17** wherein the elastically collapsible leg is formed from a super elastic material.

**21.** The inner tube of claim **17** wherein the elastically collapsible leg further comprises a cutting edge.

**22.** The inner tube of claim **17** wherein:

the interior cavity of the outer cannula is defined by an interior cavity wall;  
 the elastically collapsible leg further comprises a cutting edge; and  
 the collapsed position of the elastically collapsible leg positions the cutting edge across a portion of the interior cavity of the inner tube and against a portion of the interior cavity wall of the outer cannula.

**23.** The inner tube of claim **17** wherein the elastically collapsible leg is coupled to a distal portion of the inner tube and the distal portion of the outer cannula.

**24.** The inner tube of claim **17** wherein the elastically collapsible leg is further configured to return to a neutral position by a rearward movement of the proximal section of the elastically collapsible leg.

**25.** A tissue removal assembly comprising:

an outer cannula;  
 an inner tube slidably received in the outer cannula;  
 a holder assembly configured to provide a forward force on the inner tube and a restraining force on the outer cannula; and  
 an elastically collapsible section coupled to the inner tube and the outer cannula whereby the forward force on the inner tube and the restraining force on the outer cannula collapses the elastically collapsible section into a collapsed position.

**26.** The tissue removal assembly of claim **25** wherein the elastically collapsible section is further configured to return

## 22

to a neutral position by a rearward movement of a proximal section of the elastically collapsible section.

**27.** The tissue removal assembly of claim **25** wherein:

the outer cannula further comprises a proximal portion coupled to an outer cannula cam to receive the restraining force;

the inner tube further comprises a proximal portion coupled to an inner tube cam to receive the forward force; and

the holder assembly comprising a force element configured to automatically provide the forward force to the inner tube cam.

**28.** The tissue removal assembly of claim **27** further comprising:

a cocking element configured to receive a cocking force and return the tissue removal assembly to a ready configuration;

a plunger slidably received in the inner tube; and

the plunger dimensioned to have a length whereby the plunger expels a tissue portion in the inner tube when the tissue removal assembly is in the ready configuration.

**29.** The tissue removal assembly of claim **25** further comprising:

the outer cannula further comprises a proximal portion coupled to an outer cannula cam to receive the restraining force;

the inner tube further comprises a proximal portion coupled to an inner tube cam to receive the forward force; and

the forward force is a manually applied force.

**30.** The tissue removal assembly of claim **29** further comprising:

a plunger slidably received in the inner tube;

the plunger dimensioned to have a length whereby the plunger can be received in a majority of the inner tube and expel a tissue portion.

**31.** A method of tissue removal comprising the steps of:

positioning a needle assembly in a tissue;

the needle assembly comprising:

an inner tube having an interior cavity,

an outer cannula having a proximal portion, a distal portion and an interior cavity,

the interior cavity of the outer cannula having an interior diameter to slidably receive the inner tube, and

an elastically collapsible leg operably engaged with the inner tube and the outer cannula whereby a forward movement of a portion of the inner tube within the interior cavity of the outer cannula changes the elastically collapsible leg from a neutral position to a collapsed position;

engaging a tissue portion;

and

withdrawing the tissue portion from the tissue.

**32.** The method of claim **31** wherein the step of engaging a tissue portion further comprises:

applying a forward force to the inner tube; and

changing the elastically collapsible leg from the neutral position to the collapsed position whereby the elastically collapsible leg engages the tissue portion in the needle assembly.

**33.** The Method of claim **32** wherein the step of withdrawing the tissue portion further comprises:

withdrawing the needle assembly from the tissue;

applying a retrograde force on the inner tube;



returning the elastically collapsible leg to the neutral position;  
disengaging the tissue portion; and  
removing the tissue portion from the needle assembly.

34. The method of claim 33 wherein the step of removing 5  
the tissue portion from the needle assembly comprises receiving a plunger in a portion of the inner tube expelling the tissue portion.

35. The method of claim 33 further comprising reconfiguring the needle assembly into a ready configuration. 10

\* \* \* \* \*