



US009339270B2

(12) **United States Patent**
Martinez et al.

(10) **Patent No.:** **US 9,339,270 B2**
(45) **Date of Patent:** **May 17, 2016**

(54) **MEDICAL DEVICES WITH DETACHABLE PIVOTABLE JAWS**

(75) Inventors: **Michelle D. Martinez**, Winston-Salem, NC (US); **Vihar C. Surti**, Winston-Salem, NC (US); **Tyler Evans McLawhorn**, Winston-Salem, NC (US)

(73) Assignee: **Cook Medical Technologies LLC**, Bloomington, IN (US)

(*) Notice: Subject to any disclaimer, the term of this patent is extended or adjusted under 35 U.S.C. 154(b) by 728 days.

(21) Appl. No.: **13/270,851**

(22) Filed: **Oct. 11, 2011**

(65) **Prior Publication Data**
US 2012/0089158 A1 Apr. 12, 2012

Related U.S. Application Data
(63) Continuation-in-part of application No. 12/971,873, filed on Dec. 17, 2010, now Pat. No. 8,771,293.
(60) Provisional application No. 61/391,881, filed on Oct. 11, 2010.

(51) **Int. Cl.**
A61B 17/10 (2006.01)
A61B 17/08 (2006.01)
A61B 17/122 (2006.01)
(Continued)

(52) **U.S. Cl.**
CPC *A61B 17/10* (2013.01); *A61B 17/08* (2013.01); *A61B 17/122* (2013.01); *A61B 17/1285* (2013.01); *A61B 17/29* (2013.01); *A61B 2017/00473* (2013.01); *A61B 2017/12004* (2013.01); *A61B 2017/2902* (2013.01); *A61B 2017/2931* (2013.01);
(Continued)

(58) **Field of Classification Search**
CPC A61B 17/08; A61B 17/10; A61B 17/122; A61B 17/128; A61B 17/1285; A61B 2017/00473; A61B 2017/2902; A61B 2017/2931; A61B 2017/2943; A61B 2017/294; A61B 2017/2944; A61B 2017/2939
USPC 606/139, 142-143, 205
See application file for complete search history.

(56) **References Cited**

U.S. PATENT DOCUMENTS

720,385 A 2/1903 Storle
2,614,445 A 10/1952 Riordan
(Continued)

FOREIGN PATENT DOCUMENTS

DE 4404766 A1 8/1995
DE 19534320 2/1997
(Continued)

OTHER PUBLICATIONS

OLYMPUS Endo Therapy brochure on the QuickClip2 Long.
(Continued)

Primary Examiner — Julian W Woo
Assistant Examiner — Shaun L David
(74) *Attorney, Agent, or Firm* — Brinks Gilson & Lione

(57) **ABSTRACT**

Medical systems, devices and methods are provided for engaging tissue, e.g. for clipping tissue, closing a perforation or performing hemostasis. Generally, the medical system including a housing, first and second jaws rotatable relative to the housing, a driver, and an elongate drive wire. The elongate drive wire may be disconnected from the driver, first and second jaws, and the housing, which are left in vivo engaged with the tissue.

16 Claims, 19 Drawing Sheets

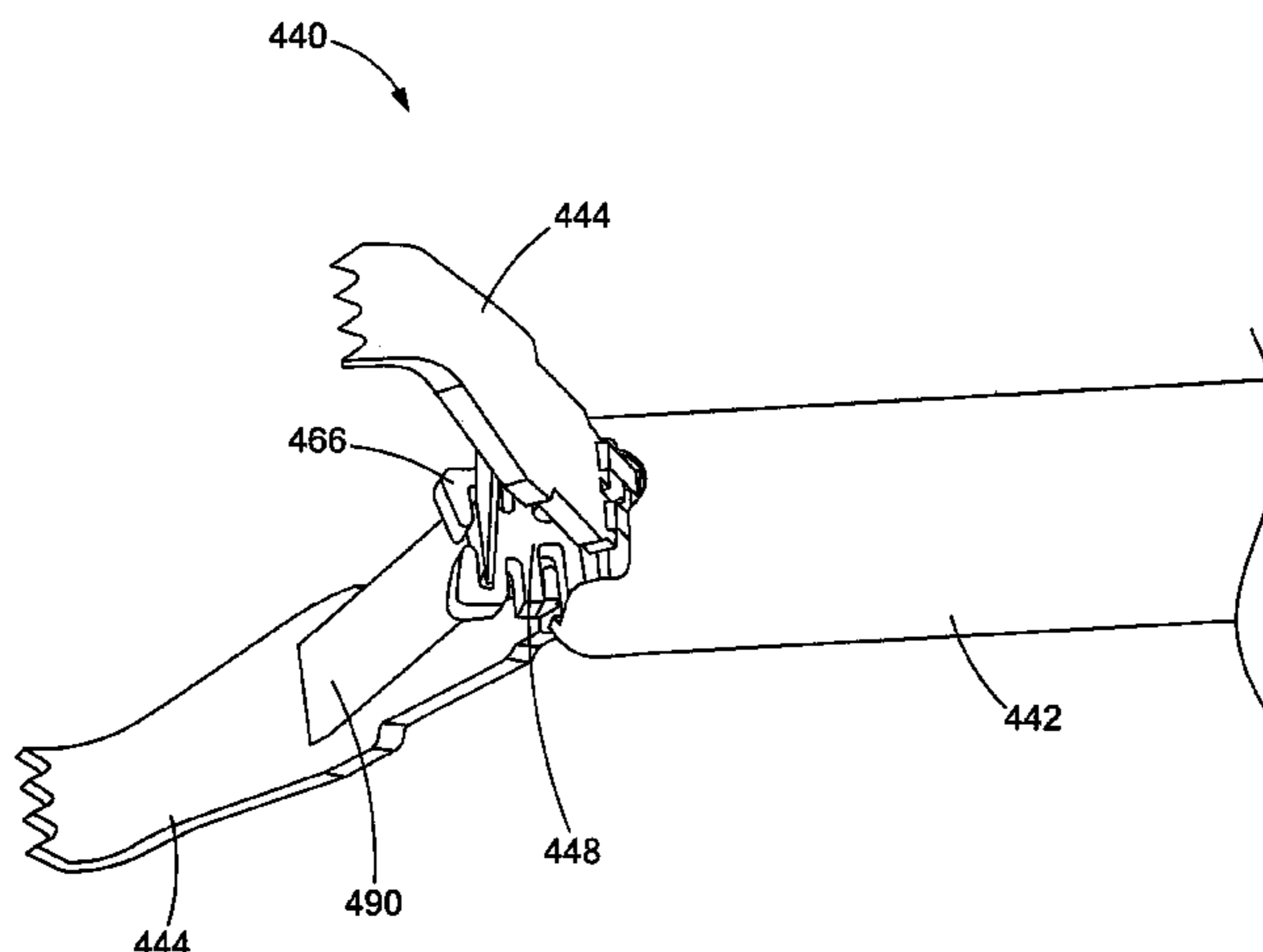

(51)	Int. Cl.		8,545,519 B2	10/2013	Aguirre et al.
	<i>A61B 17/128</i>	(2006.01)	8,771,293 B2	7/2014	Surti et al.
	<i>A61B 17/29</i>	(2006.01)	2002/0151916 A1	10/2002	Muramatsu et al.
	<i>A61B 17/00</i>	(2006.01)	2002/0173805 A1	11/2002	Matsuno et al.
	<i>A61B 17/12</i>	(2006.01)	2002/0177861 A1	11/2002	Sugiyama et al.
(52)	U.S. Cl.		2003/0069592 A1	4/2003	Adams et al.
	CPC <i>A61B 2017/2936</i> (2013.01); <i>A61B 2017/2943</i>		2003/0097146 A1	5/2003	Montalvo et al.
	(2013.01); <i>A61B 2017/2944</i> (2013.01)		2004/0044363 A1	3/2004	Fowler
			2005/0059985 A1	3/2005	Kimura
			2005/0101991 A1	5/2005	Ahlberg et al.
			2005/0234296 A1	10/2005	Saadat et al.
			2005/0251183 A1	11/2005	Buckman et al.
			2005/0272977 A1	12/2005	Saadat et al.
			2006/0084886 A1	4/2006	Reydel
			2006/0155308 A1	7/2006	Griego
			2006/0258905 A1	11/2006	Kaji et al.
			2006/0259045 A1	11/2006	Damarati
			2007/0073185 A1	3/2007	Nakao
			2007/0135678 A1	6/2007	Suzuki
			2007/0239162 A1	10/2007	Bhatnagar et al.
			2007/0250113 A1	10/2007	Hegeman et al.
			2007/0282355 A1*	12/2007	Brown et al. 606/151
			2007/0287993 A1	12/2007	Hinman et al.
			2008/0004656 A1	1/2008	Livneh
			2008/0147113 A1	6/2008	Nobis et al.
			2008/0171907 A1	7/2008	Long et al.
			2008/0228199 A1	9/2008	Cropper et al.
			2008/0228202 A1	9/2008	Cropper et al.
			2008/0234703 A1	9/2008	Cropper et al.
			2008/0234705 A1	9/2008	Cropper et al.
			2008/0255427 A1	10/2008	Satake et al.
			2008/0262539 A1	10/2008	Ewers et al.
			2008/0269557 A1	10/2008	Marescaux et al.
			2008/0269566 A1	10/2008	Measamer
			2008/0275441 A1	11/2008	Aue
			2008/0287963 A1	11/2008	Rogers et al.
			2008/0294178 A1	11/2008	Kortenbach et al.
			2008/0300461 A1	12/2008	Shaw et al.
			2008/0300624 A1	12/2008	Schwemberger et al.
			2009/0005638 A1	1/2009	Zwolinski
			2009/0018602 A1	1/2009	Mitelberg et al.
			2009/0043316 A1	2/2009	Durgin et al.
			2009/0062792 A1	3/2009	Vakharia et al.
			2009/0138006 A1	5/2009	Bales et al.
			2009/0138028 A1	5/2009	Wells et al.
			2009/0143794 A1	6/2009	Conlon et al.
			2009/0163934 A1	6/2009	Raschdorf, Jr. et al.
			2009/0192344 A1	7/2009	Bakos et al.
			2009/0221915 A1	9/2009	Voegele et al.
			2009/0299385 A1	12/2009	Stefanchik et al.
			2009/0306683 A1	12/2009	Zwolinski et al.
			2009/0306686 A1	12/2009	Ohdaira
			2009/0326518 A1	12/2009	Rabin
			2009/0326578 A1	12/2009	Ewers et al.
			2010/0042115 A1	2/2010	Saadat et al.
			2010/0057078 A1	3/2010	Arts et al.
			2010/0057085 A1	3/2010	Holcomb et al.
			2010/0130817 A1	5/2010	Conlon
			2010/0168787 A1	7/2010	Surti
			2010/0179540 A1	7/2010	Marczyk et al.
			2010/0198149 A1	8/2010	Fox
			2010/0198248 A1	8/2010	Vakharia
			2010/0211086 A1	8/2010	Ewers et al.
			2010/0217151 A1	8/2010	Gostout et al.
			2010/0217292 A1	8/2010	Kimura et al.
			2010/0217293 A1	8/2010	Kimura et al.
			2010/0217294 A1	8/2010	Kimura et al.
			2010/0249498 A1	9/2010	Wingardner et al.
			2010/0249700 A1	9/2010	Spivey
			2010/0249808 A1	9/2010	Harada et al.
			2012/0016391 A1	1/2012	Aguirre
			2012/0089176 A1	4/2012	Sigmon, Jr. et al.
			2012/0109160 A1	5/2012	Martenez et al.
			2012/0165863 A1	6/2012	McLawhorn
(56)	References Cited				
	U.S. PATENT DOCUMENTS				
	3,958,576 A	5/1976	Komiya		
	4,467,802 A	8/1984	Maslanka		
	4,512,345 A	4/1985	Green		
	4,569,131 A	2/1986	Falk et al.		
	4,733,664 A	3/1988	Kirsch et al.		
	4,763,668 A	8/1988	Macek et al.		
	4,765,335 A	8/1988	Schmidt et al.		
	4,805,618 A	2/1989	Ueda et al.		
	4,950,273 A	8/1990	Briggs		
	5,029,355 A	7/1991	Thai		
	5,049,153 A *	9/1991	Nakao et al. 606/151		
	5,100,418 A	3/1992	Yoon et al.		
	5,141,519 A	8/1992	Smith et al.		
	5,147,357 A *	9/1992	Rose et al. 606/49		
	5,152,778 A	10/1992	Bales, Jr. et al.		
	5,174,276 A	12/1992	Crockard		
	5,192,298 A	3/1993	Smith et al.		
	5,201,743 A	4/1993	Haber et al.		
	5,209,747 A	5/1993	Knoepfler		
	5,275,608 A	1/1994	Forman et al.		
	5,275,613 A	1/1994	Haber et al.		
	5,275,615 A	1/1994	Rose		
	5,282,806 A	2/1994	Haber et al.		
	5,318,589 A	6/1994	Lichtman		
	5,368,606 A	11/1994	Marlow et al.		
	5,471,992 A	12/1995	Banik et al.		
	5,509,923 A	4/1996	Middleman et al.		
	5,571,137 A	11/1996	Marlow et al.		
	5,618,303 A	4/1997	Marlow et al.		
	5,632,764 A	5/1997	Beideman et al.		
	5,702,407 A	12/1997	Kaji		
	5,766,184 A	6/1998	Matsuno et al.		
	5,766,189 A	6/1998	Matsuno		
	5,792,165 A	8/1998	Klieman et al.		
	5,797,923 A	8/1998	Aiyar et al.		
	5,964,779 A	10/1999	Mayenberger et al.		
	6,059,719 A	5/2000	Yamamoto et al.		
	6,258,105 B1 *	7/2001	Hart et al. 606/142		
	6,358,197 B1	3/2002	Silverman et al.		
	6,814,742 B2	11/2004	Kimura et al.		
	6,923,818 B2	8/2005	Muramatsu et al.		
	7,011,667 B2	3/2006	Kobayashi et al.		
	7,041,118 B2	5/2006	Muramatsu et al.		
	7,081,121 B2	7/2006	Muramatsu et al.		
	7,223,271 B2	5/2007	Muramatsu et al.		
	7,223,272 B2	5/2007	Francese et al.		
	7,326,221 B2	2/2008	Sakamoto et al.		
	7,452,327 B2	11/2008	Durgin et al.		
	7,488,334 B2	2/2009	Jugenheimer et al.		
	7,494,461 B2	2/2009	Wells et al.		
	7,601,159 B2	10/2009	Ewers et al.		
	7,722,628 B2	5/2010	Stokes et al.		
	7,727,247 B2	6/2010	Kimura et al.		
	7,736,372 B2	6/2010	Reydel et al.		
	7,736,374 B2	6/2010	Vaughan et al.		
	7,740,639 B2	6/2010	Hummel et al.		
	7,744,613 B2	6/2010	Ewers et al.		
	7,766,810 B2	8/2010	Ohdaira		
	7,776,057 B2	8/2010	Laufer et al.		
	7,815,652 B2	10/2010	Messerly et al.		
	8,083,668 B2	12/2011	Durgin et al.		
	8,088,061 B2	1/2012	Wells et al.		
	8,172,859 B2	5/2012	Matsuno et al.		
	8,317,820 B2	11/2012	Surti		
					FOREIGN PATENT DOCUMENTS
			DE	19750878 A1	5/1999
			DE	19906360 A1	8/2000

(56)

References Cited

FOREIGN PATENT DOCUMENTS

DE	102006003548	8/2007
JP	57-156752	9/1982
JP	60-103946	6/1985
JP	63-6016	2/1988
JP	63-267345	11/1988
JP	63-288147	11/1988
JP	2-6011	1/1990
JP	2007950	1/1990
JP	4-26091	3/1992
JP	4102450	4/1992
JP	5-212043	8/1993
JP	5208020	8/1993
JP	5212042	8/1993
JP	6237939	8/1994
JP	6254101	9/1994
JP	8019548	1/1996
JP	8126648	5/1996
JP	8280701	10/1996
JP	8308847	11/1996
JP	9038093	2/1997
JP	9289989	11/1997
JP	2000-33090	2/2000
JP	2000-335631	12/2000
JP	2001-520069	10/2001
JP	2002-224124	8/2002
JP	2002-301082	10/2002
JP	2002-360585	12/2002
WO	WO 9614020	5/1996
WO	WO 99/20183	4/1999
WO	WO 2004/017839	4/2004
WO	WO 2008/005433	1/2008
WO	WO 2010/078163	7/2010
WO	WO 2011/087723	7/2011
WO	WO 2012/051188	4/2012
WO	WO 2012/051200	4/2012
WO	WO 2012/083041	6/2012
WO	2012/051200	11/2012

OTHER PUBLICATIONS

Cooper Surgical brochure on the Marlow Nu-Tip Laparoscopic Instruments.

Medwork brochure, Endo Therapy for the Clipmaster 3.
 Boston Scientific Catalog on the Resolution Clip Device.
 Medicon Instrument Catalog, pp. 440, 441, 443, 451, 585, 686 (1986).
 V. Mueller, The Surgical Armamentarium, pp. F176-F177 (1988).
 Annex to Form PCT/ISA/206—Communication Relating to the Results of Partial International Search for PCT/US2011/055800 (Jun. 28, 2012).
 International Search Report/Written Opinion for PCT/US2009/069270 (May 17, 2010).
 International Search Report/Written Opinion for PCT/US2010/061077 (Apr. 1, 2011).
 International Search Report and Opinion for PCT/US2011/055780 (Jun. 14, 2012).
 International Search Report and Opinion for PCT/US2011/055786 (Jun. 19, 2012).
 International Search Report and Opinion for PCT/US2011/065200 (Jun. 13, 2012).
 International Search Report and Opinion for PCT/US2011/055800 (Sep. 12, 2012).
 International Search Report and Opinion for PCT/US2012/046666 (Oct. 8, 2012).
 Office Action dated Jan. 18, 2012 for U.S. Appl. No. 12/645,004 in related application.
 Office Action dated May 29, 2012 for U.S. Appl. No. 12/645,004 in related application.
 Office Action dated Dec. 20, 2012 for U.S. Appl. No. 13/186,427 in related application.
 Office Action dated Nov. 6, 2013 U.S. Appl. No. 12/971,873 in related application.
 Office Action dated Dec. 24, 2013 U.S. Appl. No. 13/270,784 in related application.
 Office Action dated May 6, 2013 U.S. Appl. No. 12/971,873 in related application.
 Office Action dated Feb. 26, 2014 U.S. Appl. No. 13/327,127 in related application.
 Office Action dated Mar. 17, 2014 U.S. Appl. No. 13/270,834 in related application.
 Office Action dated Mar. 10, 2014 U.S. Appl. No. 13/270,851 in related application.

* cited by examiner

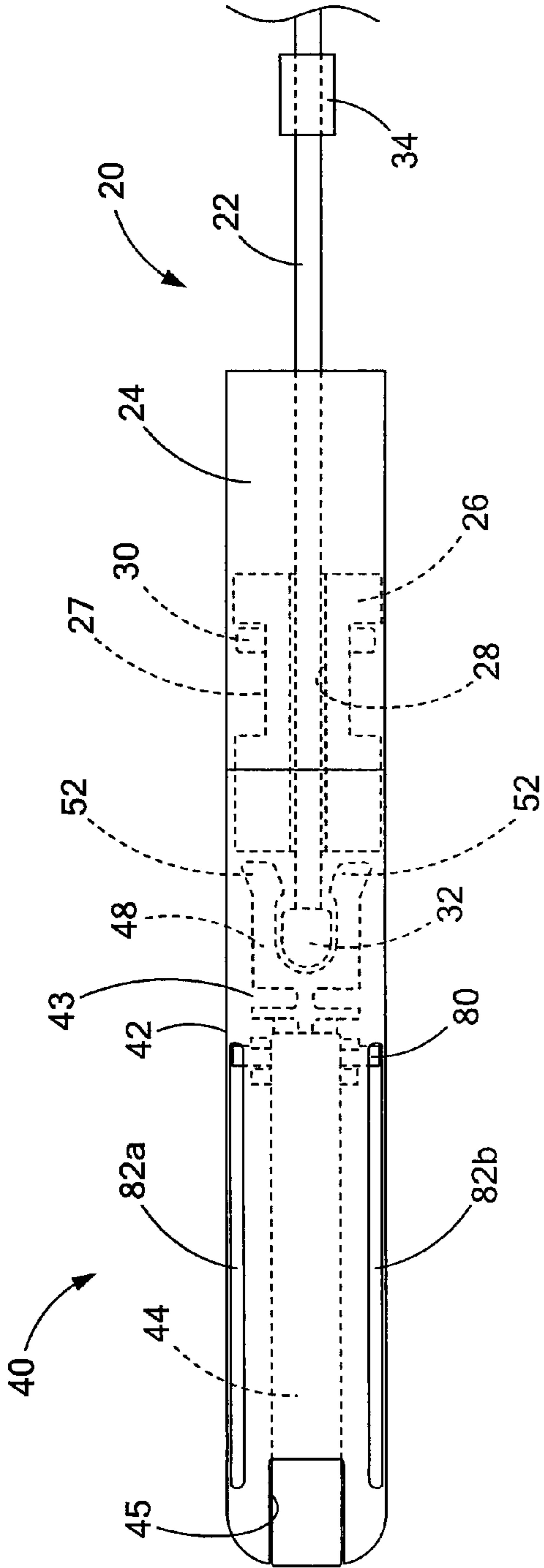

FIG. 1

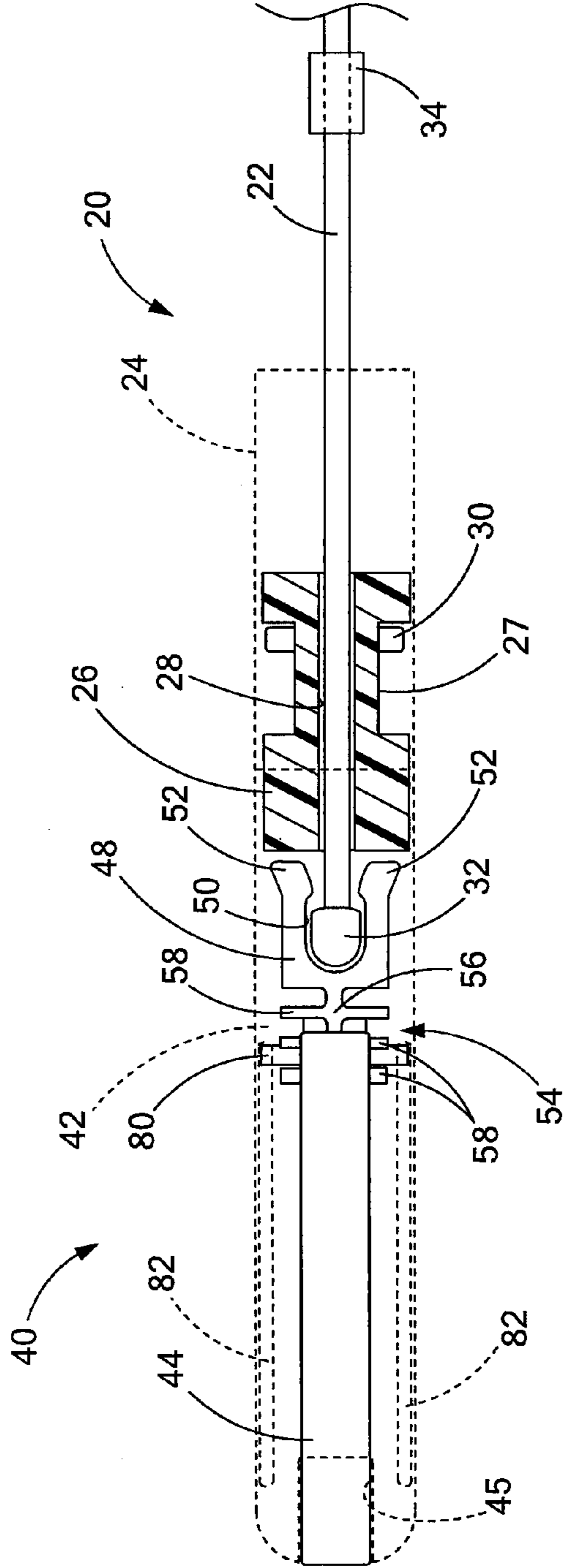

FIG. 2

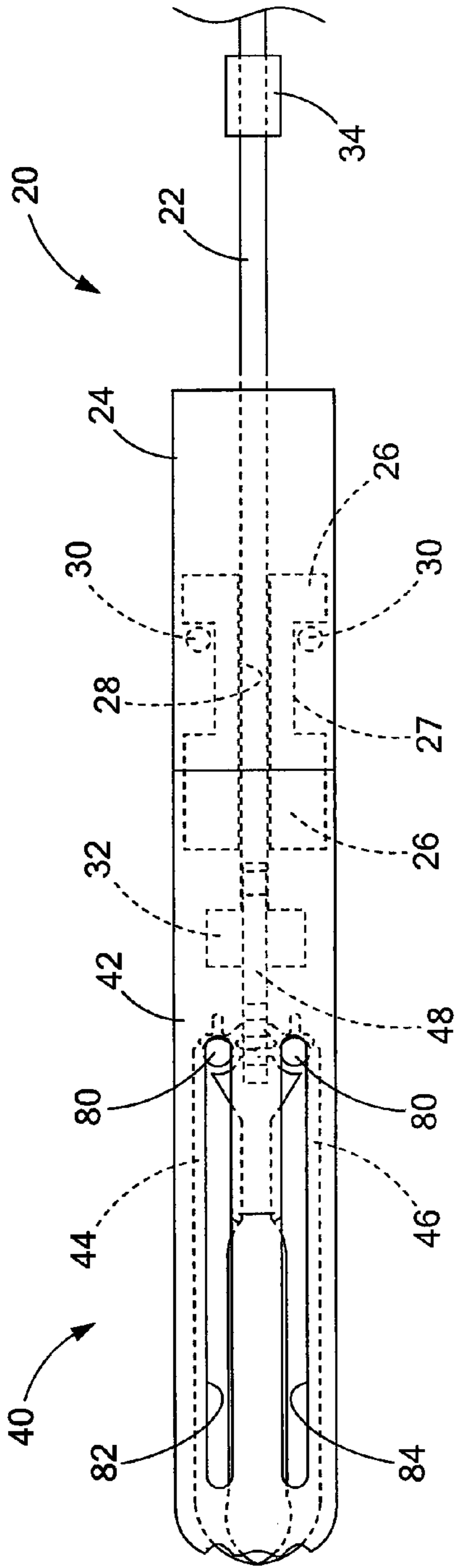

FIG. 3

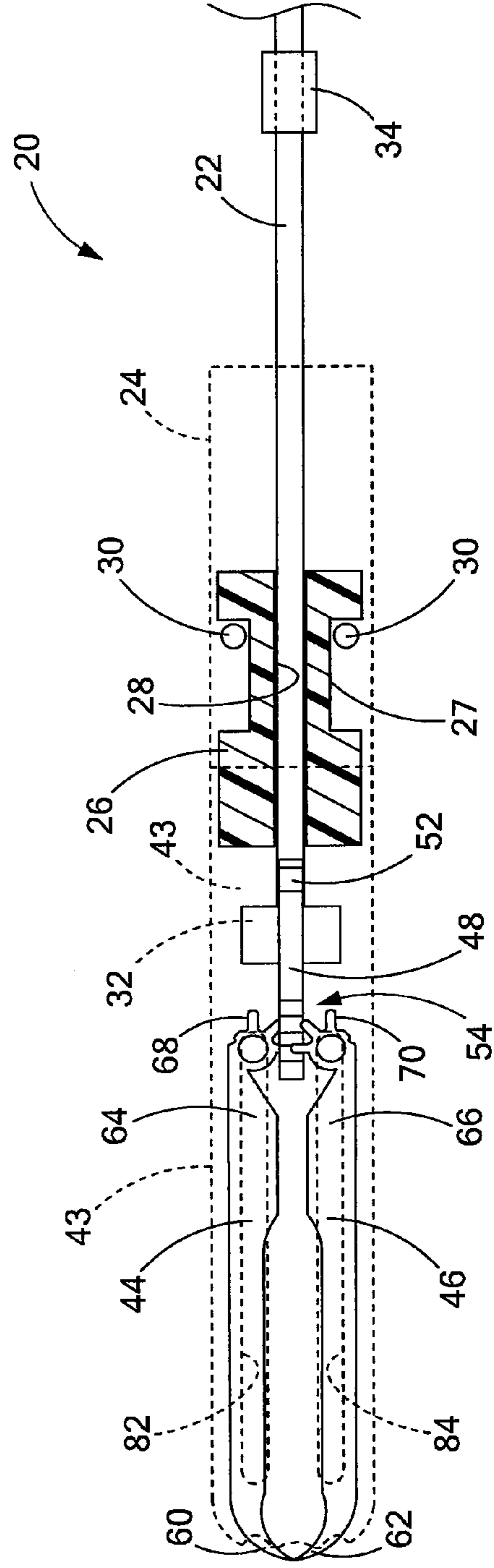

FIG. 4

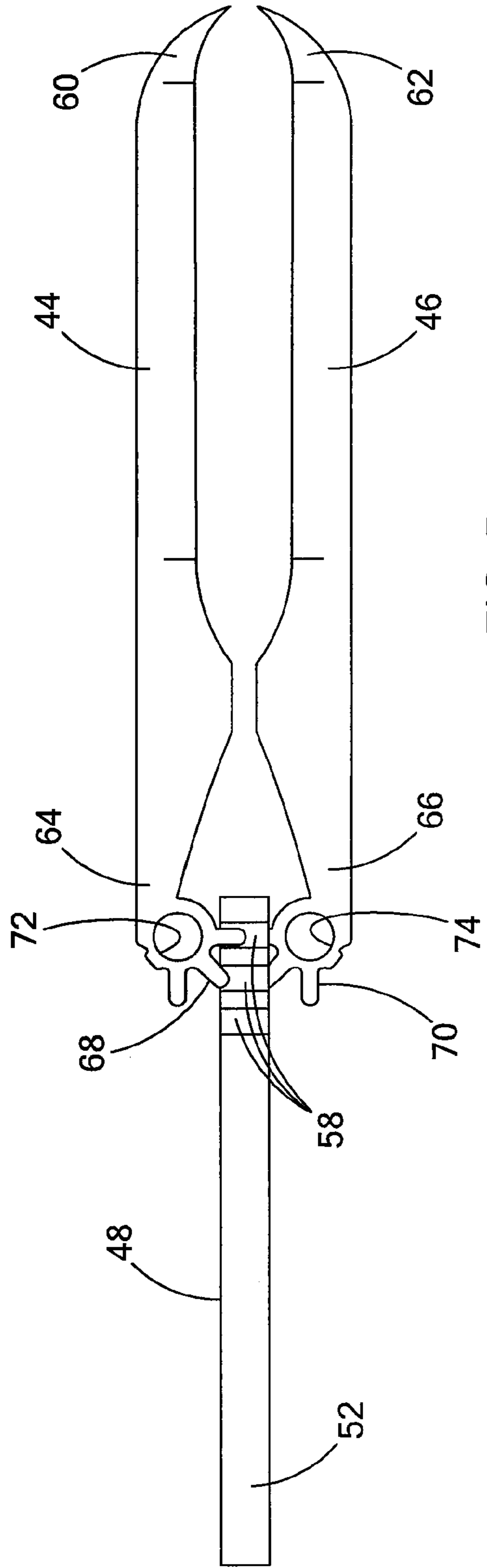

FIG. 5

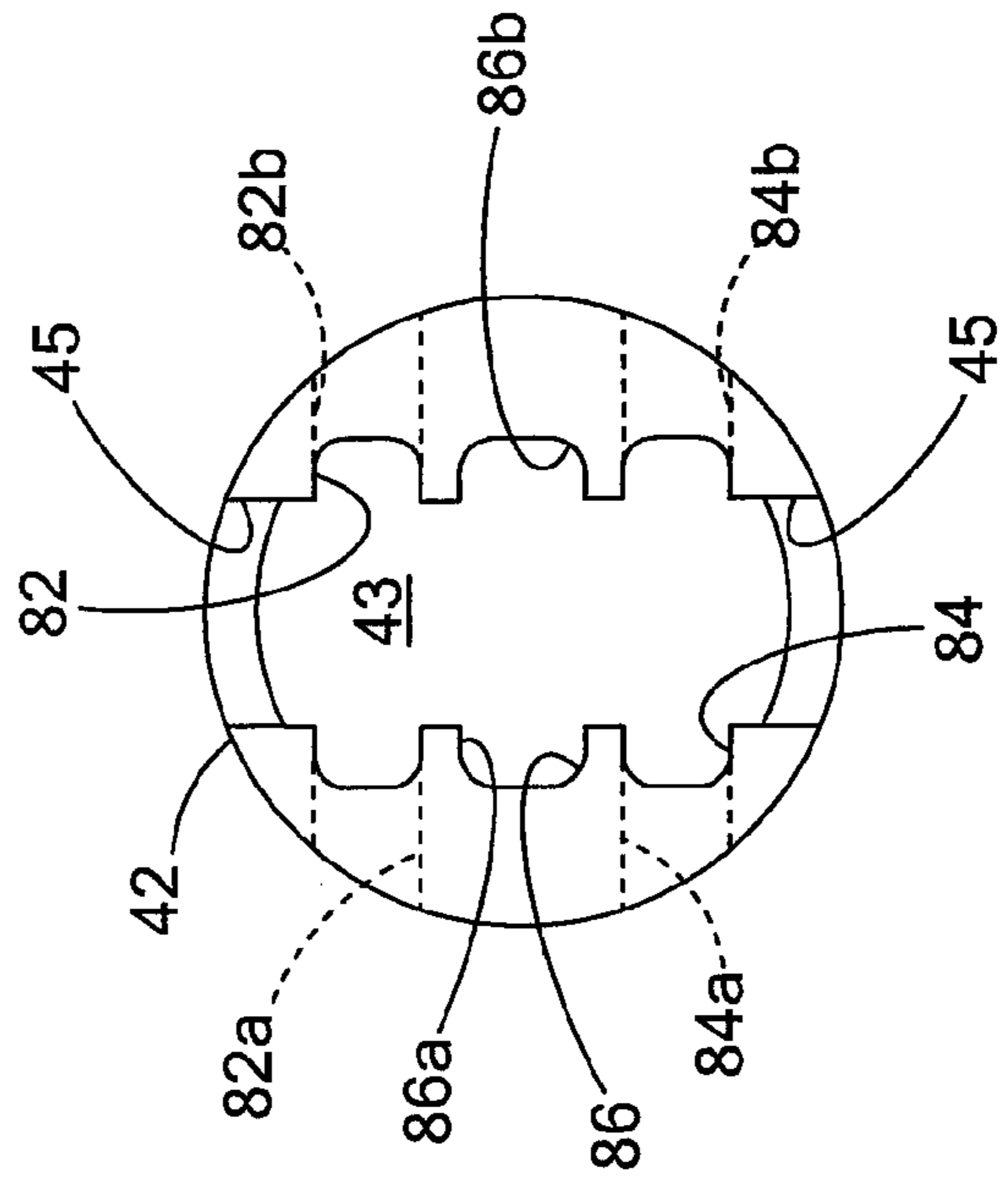

FIG. 6

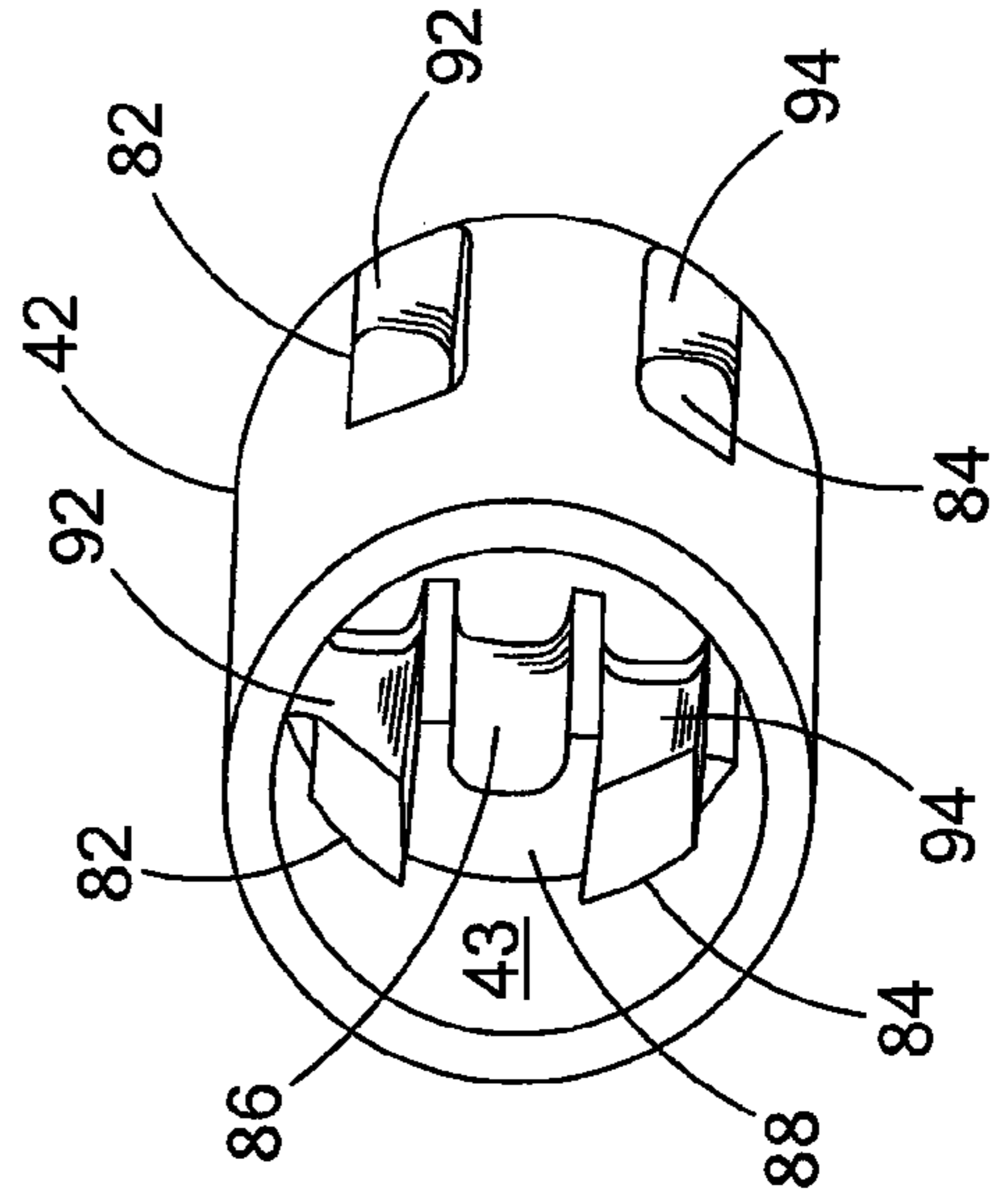

FIG. 7

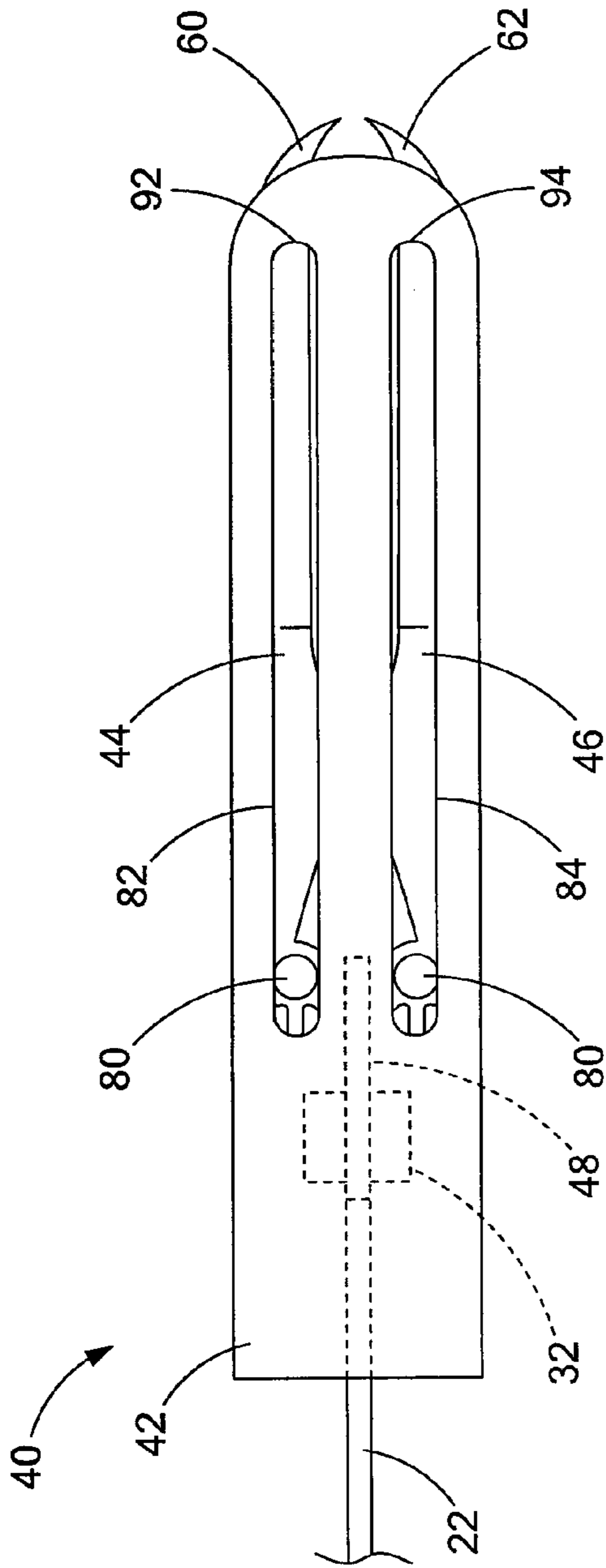

FIG. 8

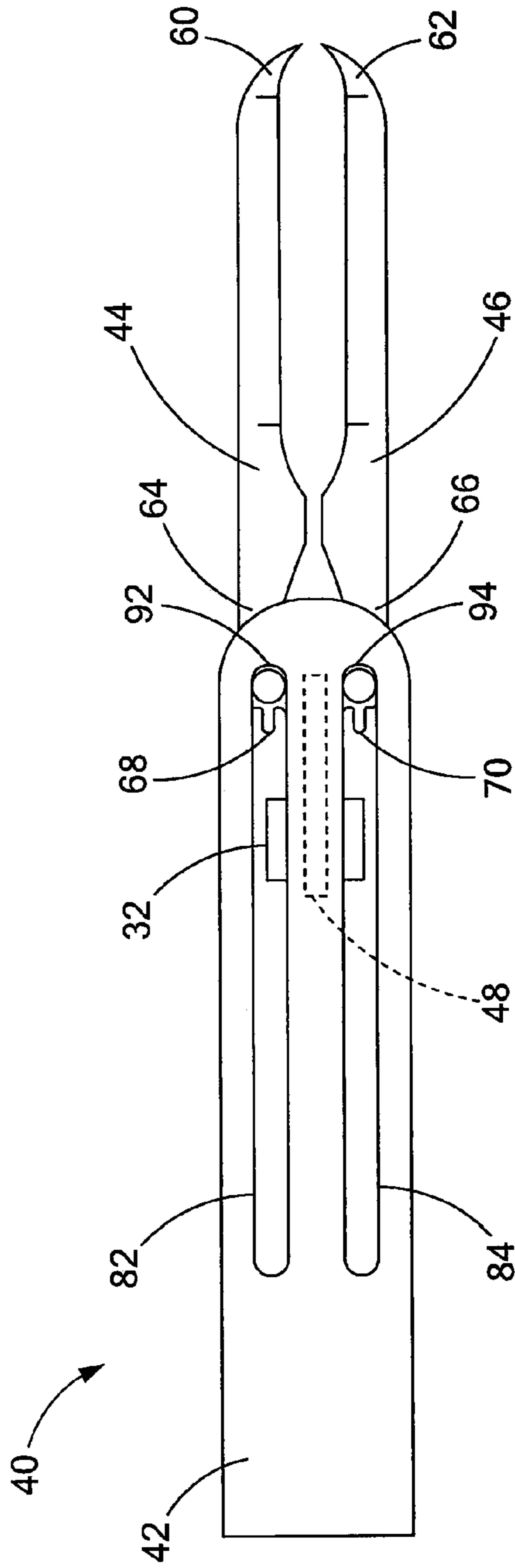

FIG. 9

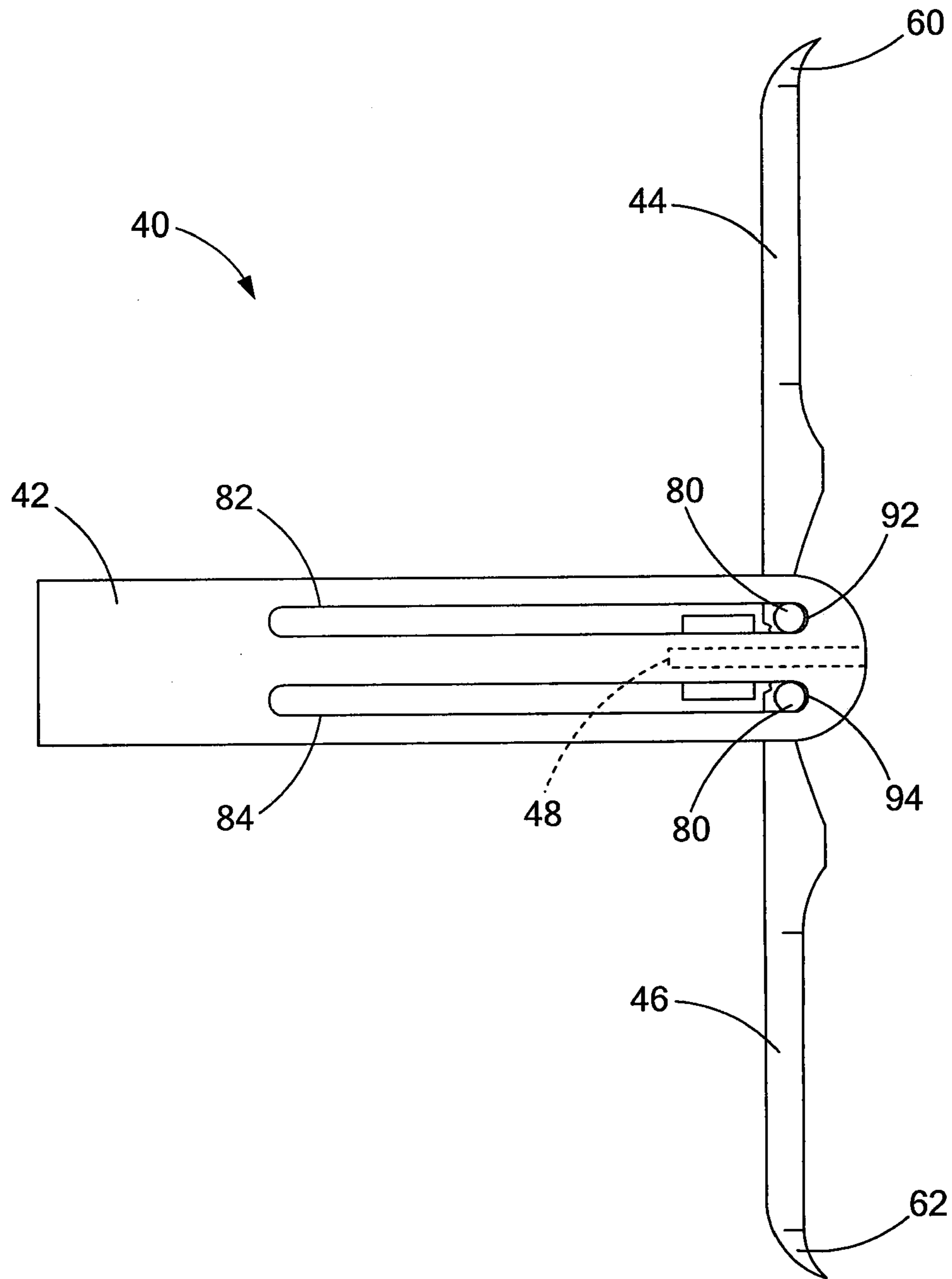

FIG. 10

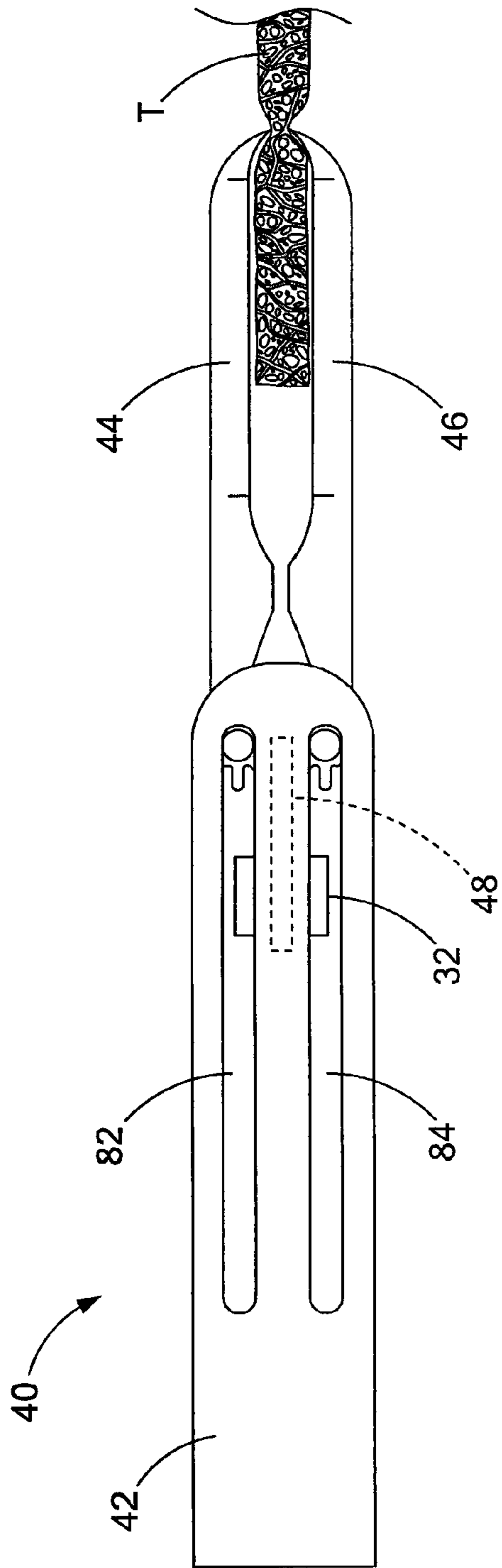

FIG. 11

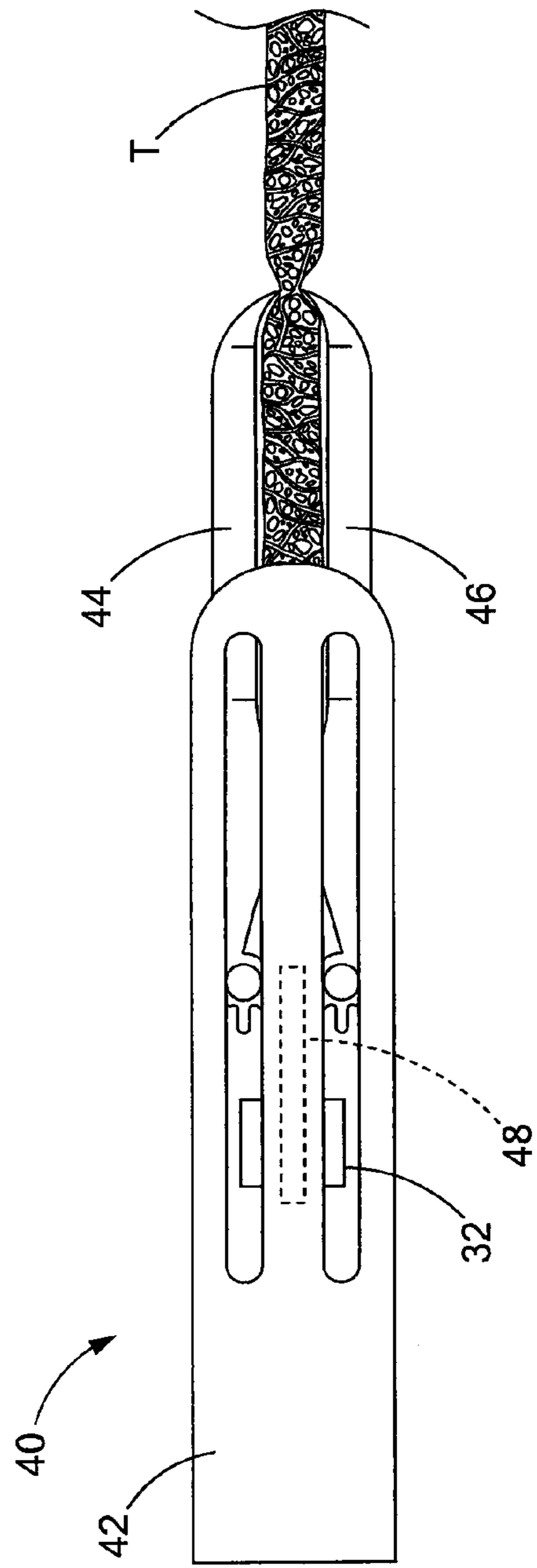

FIG. 12

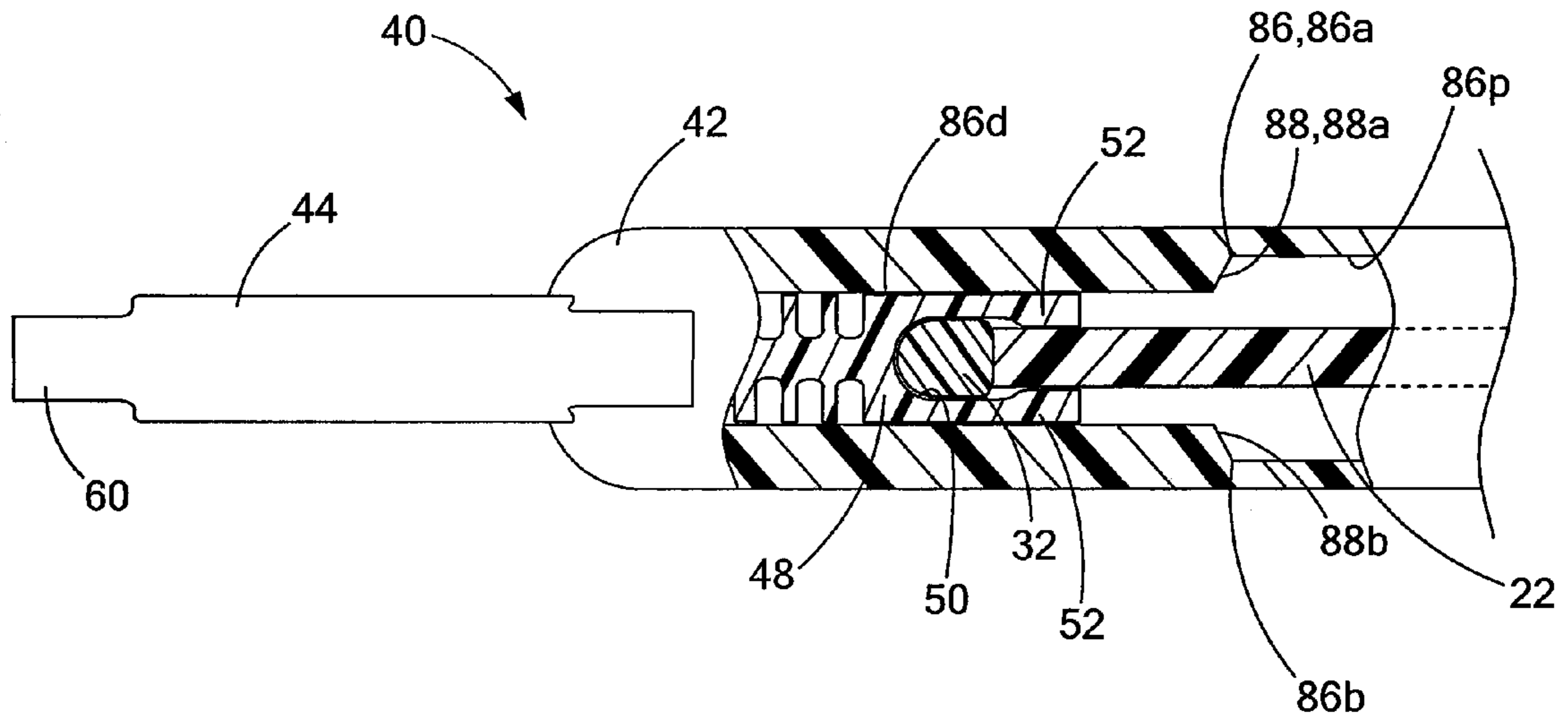

FIG. 13

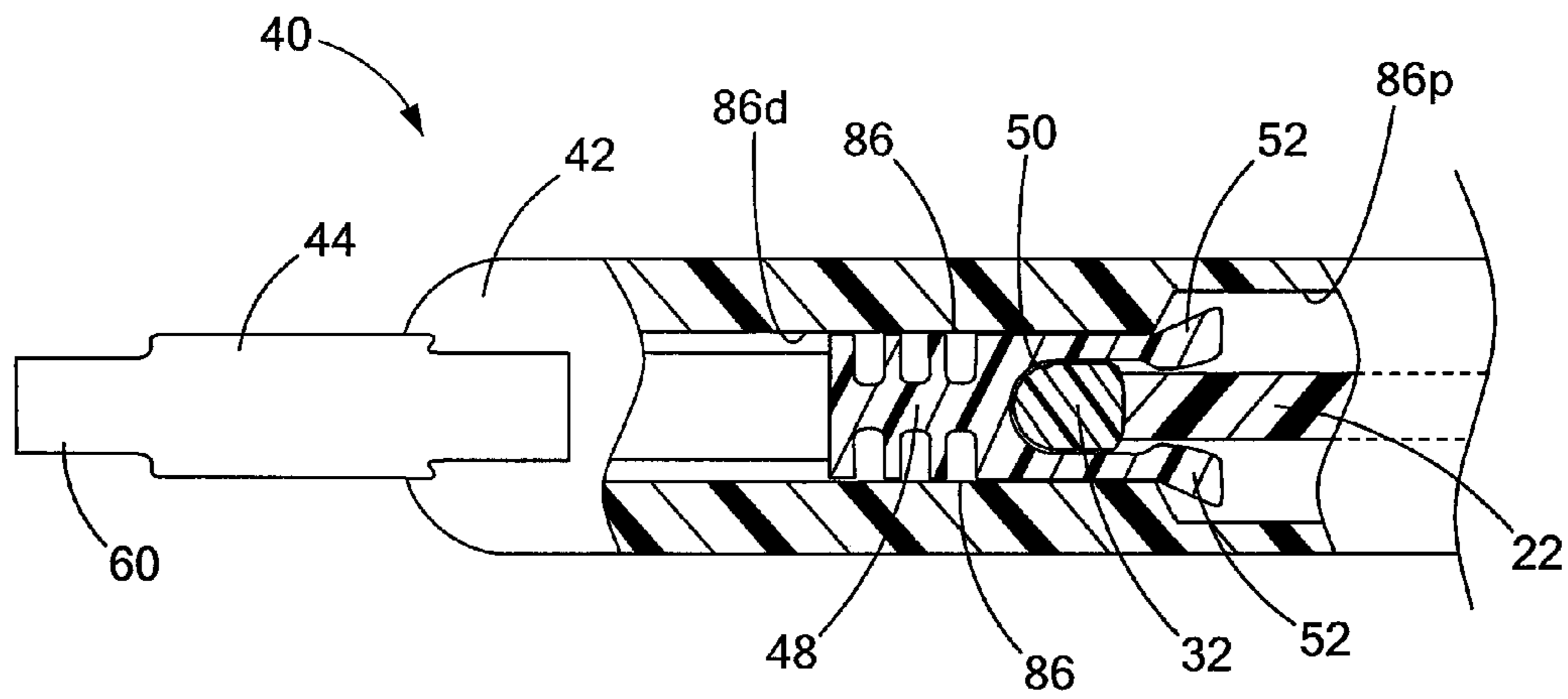

FIG. 14

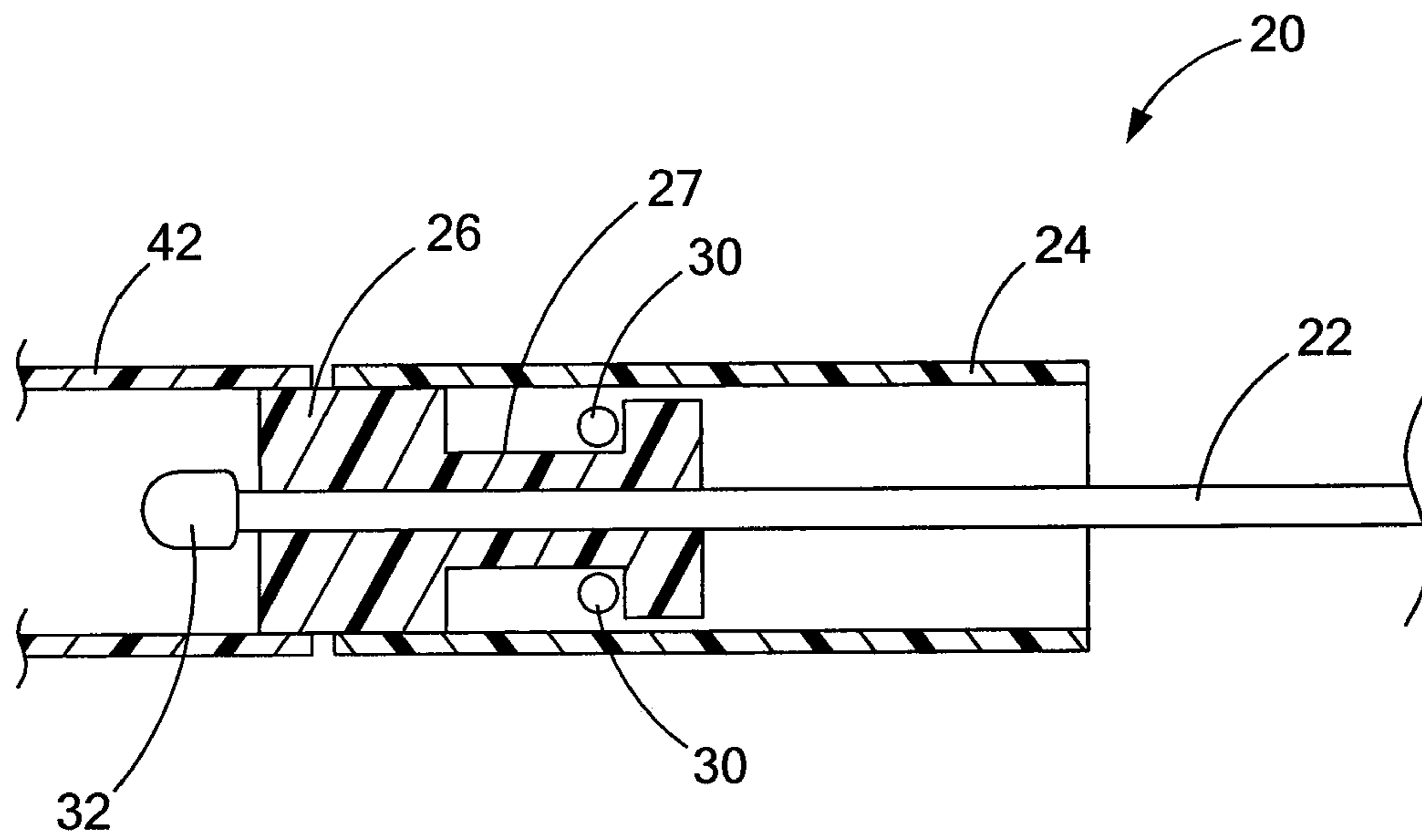

FIG. 15

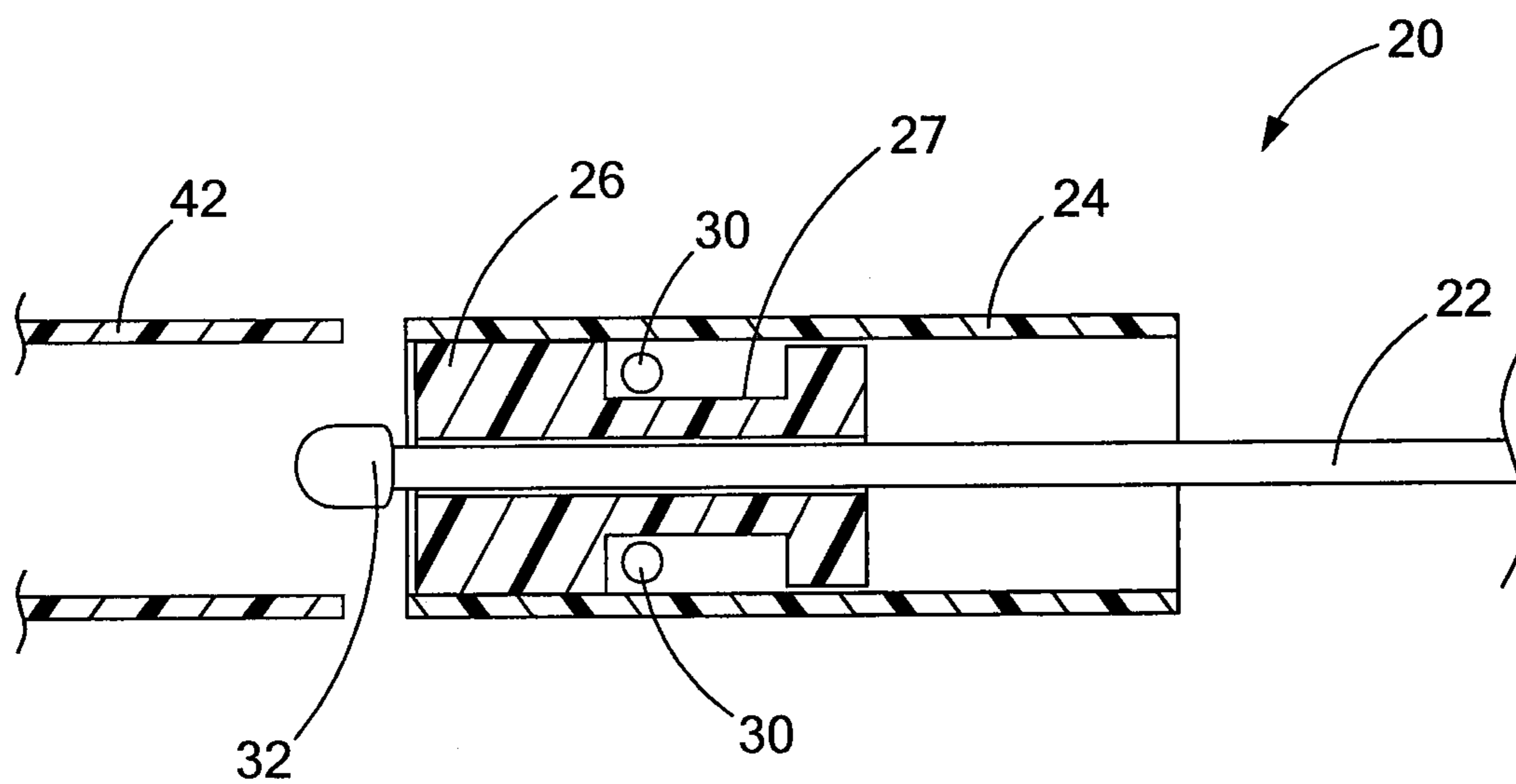

FIG. 16

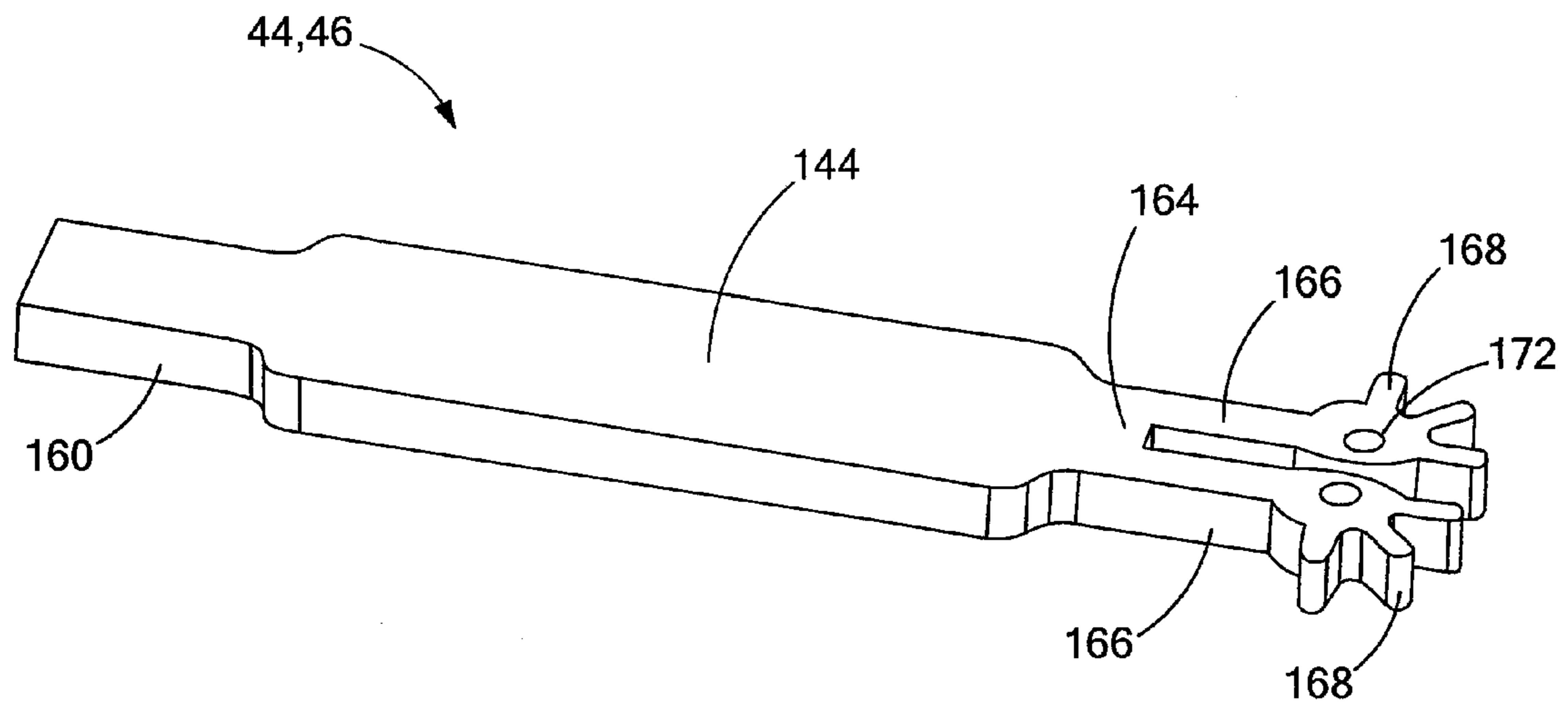

FIG. 17

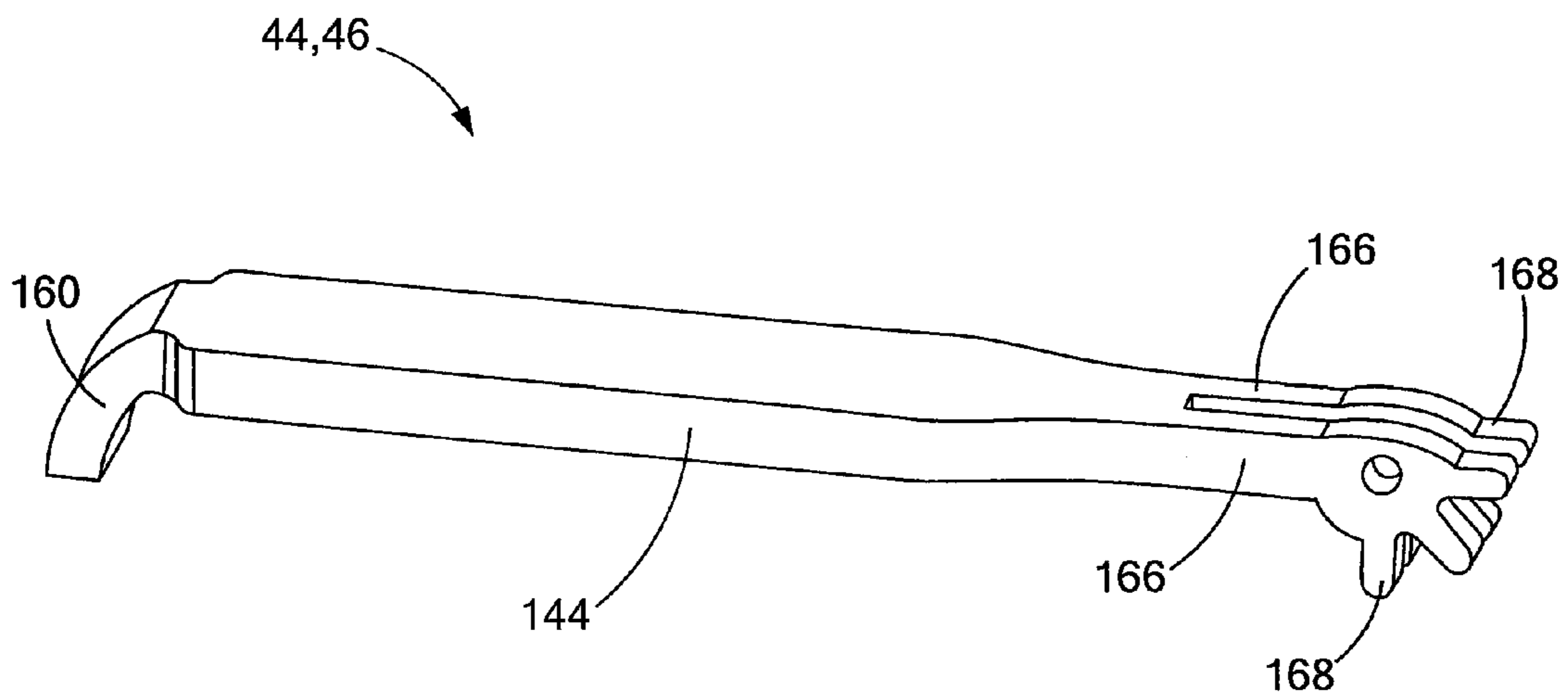

FIG. 18

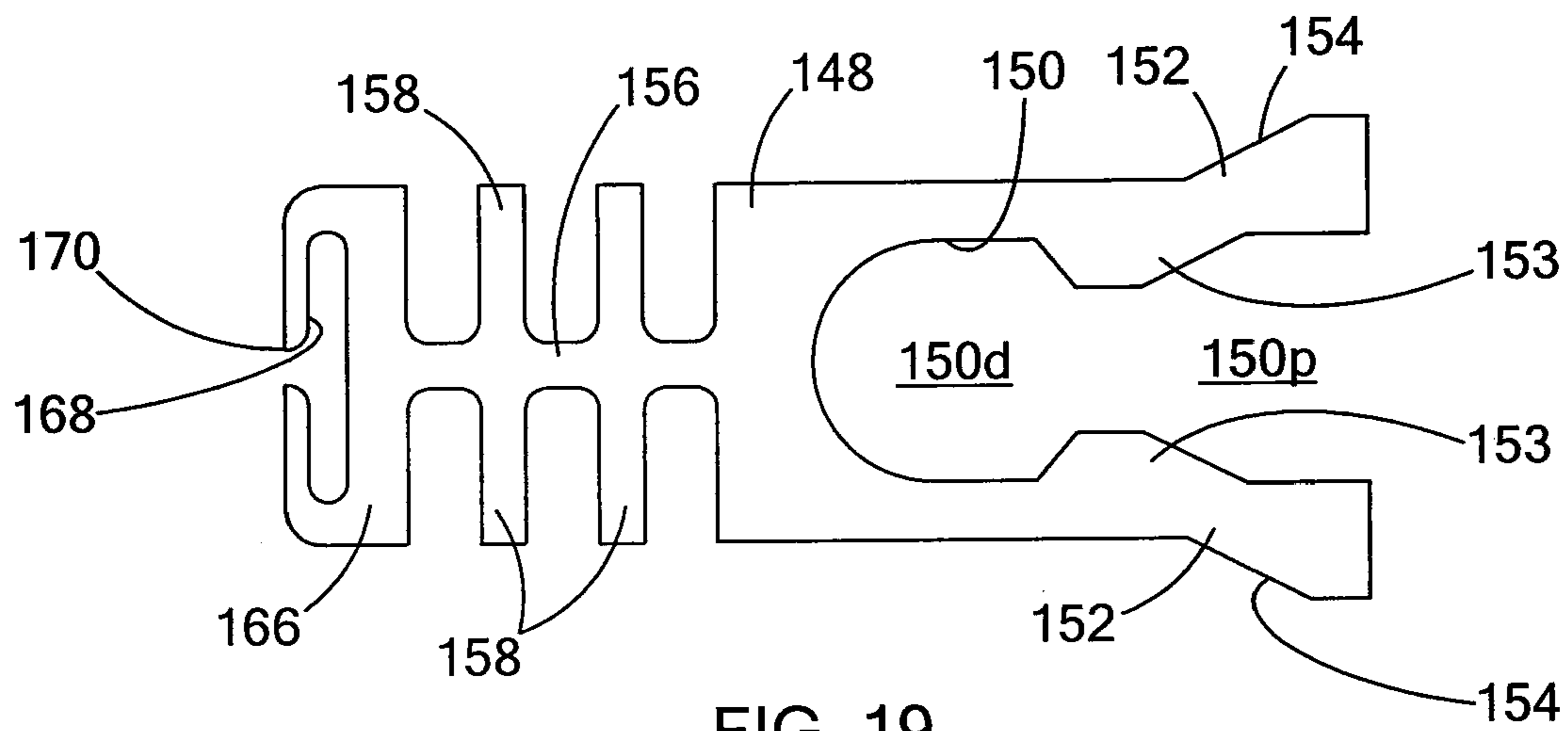

FIG. 19

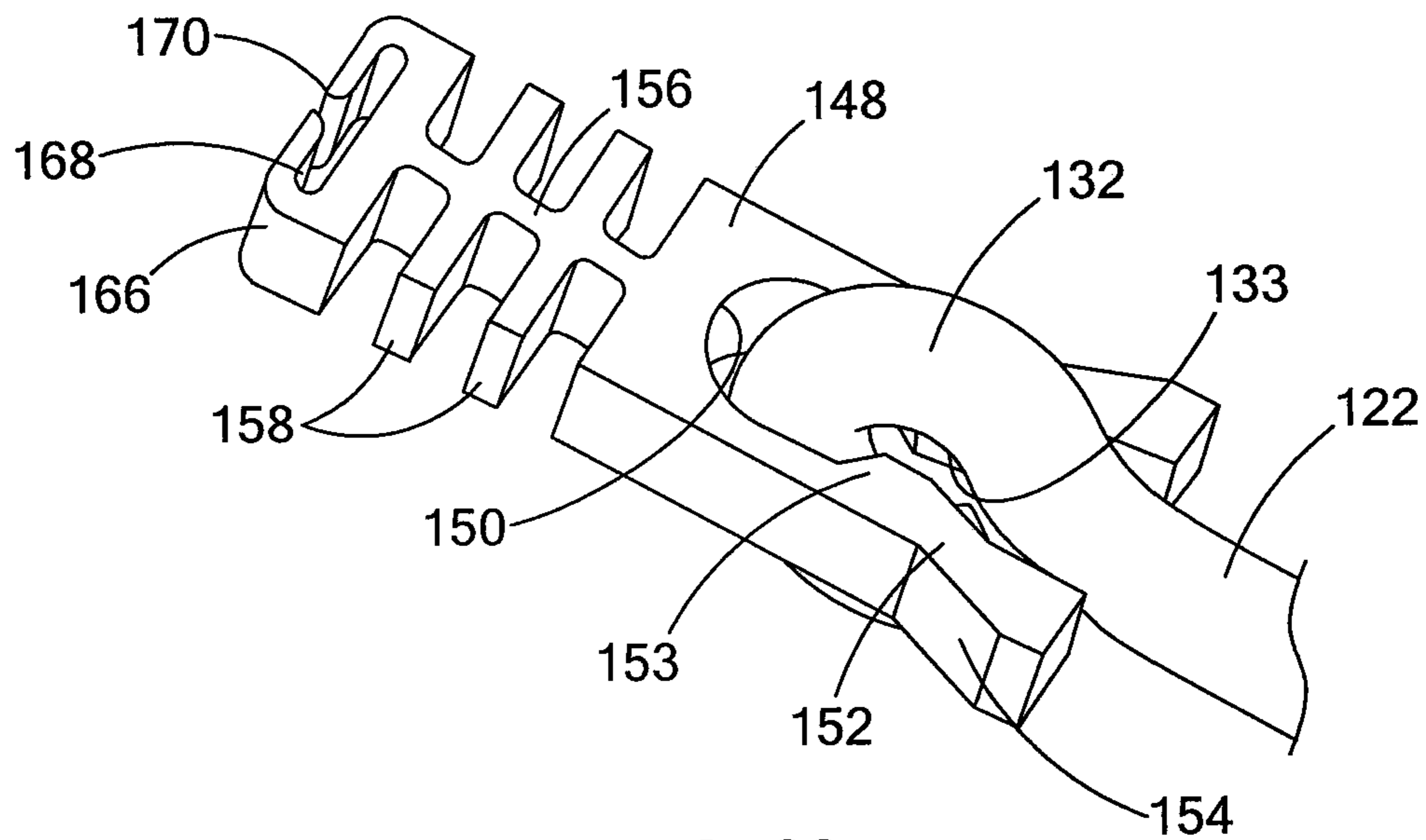

FIG. 20

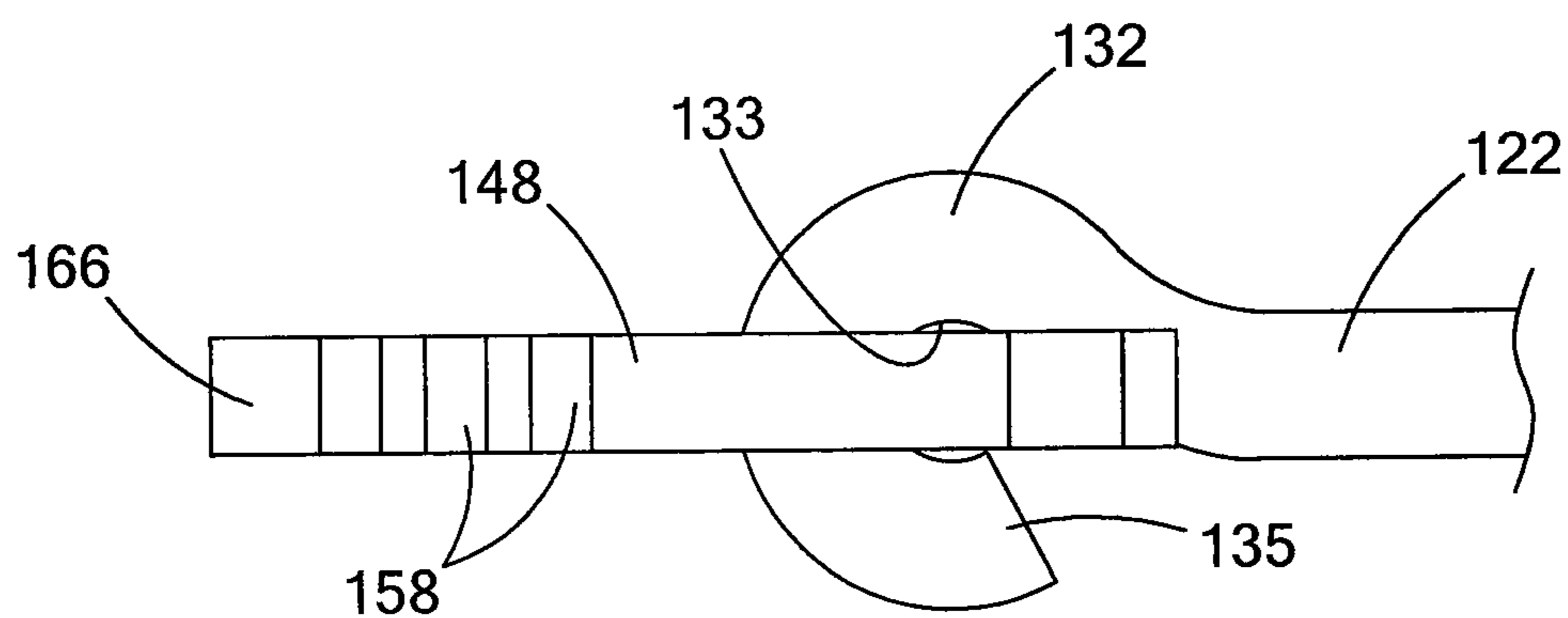

FIG. 21

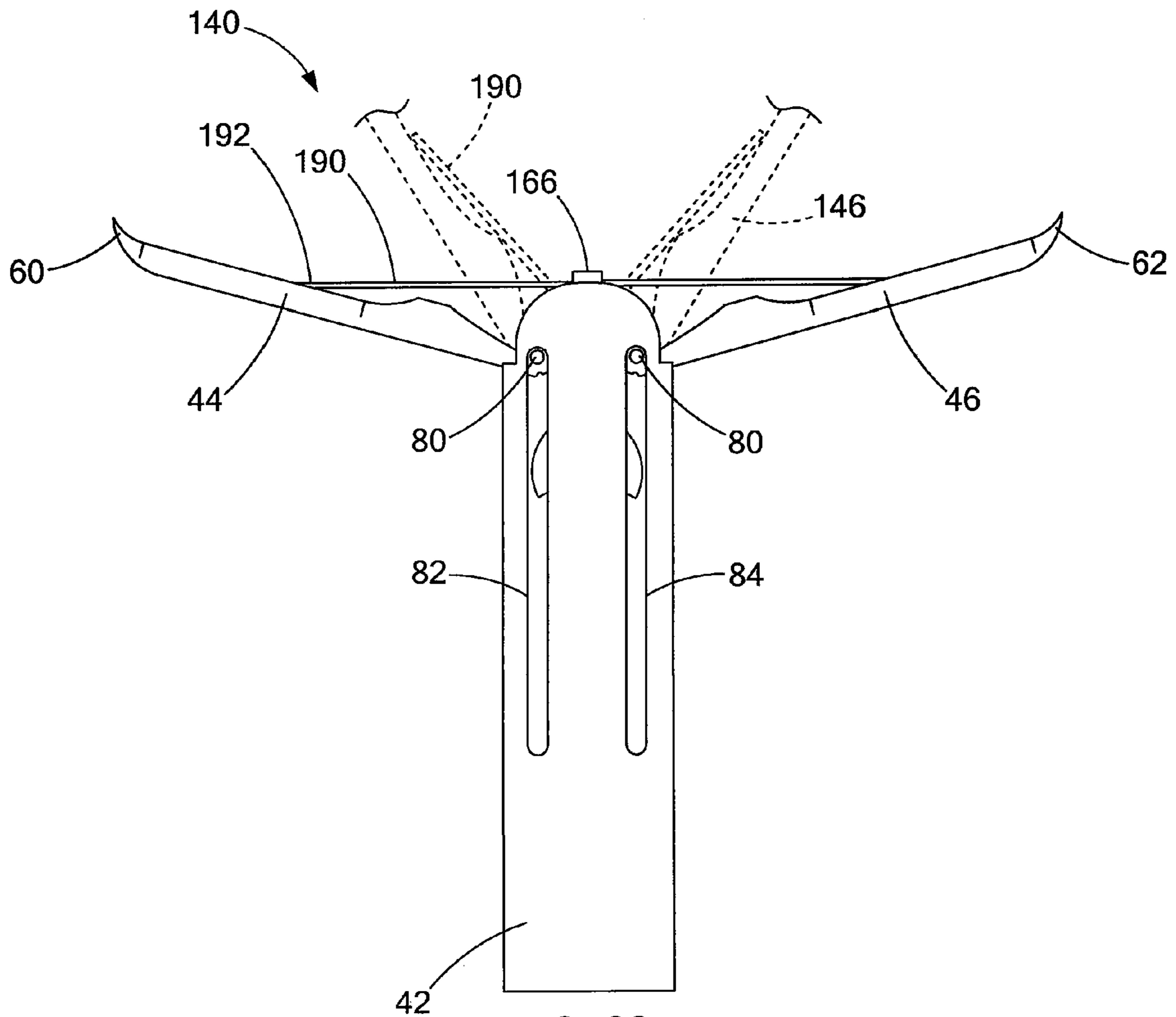

FIG. 22a

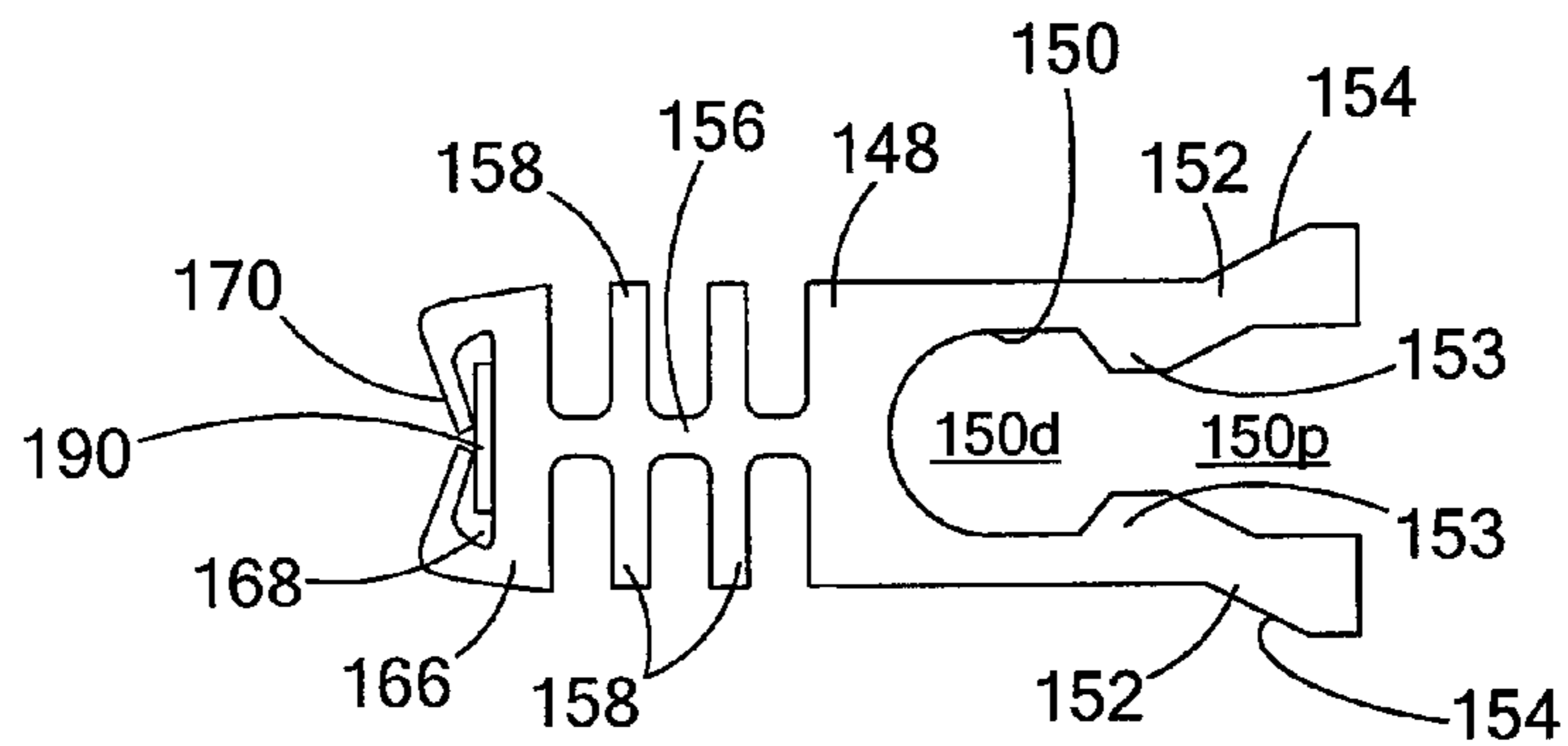

FIG. 22b

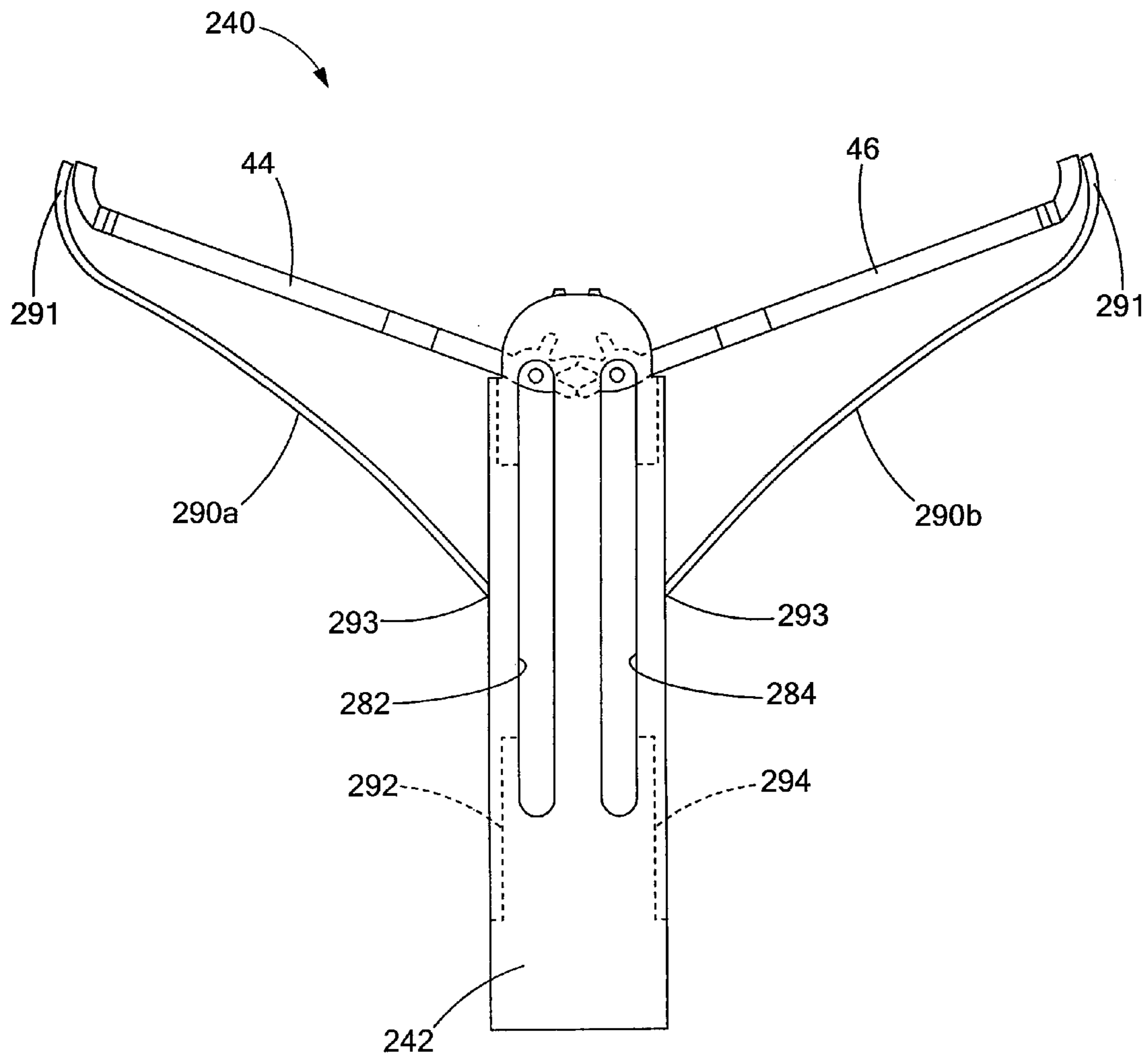

FIG. 23

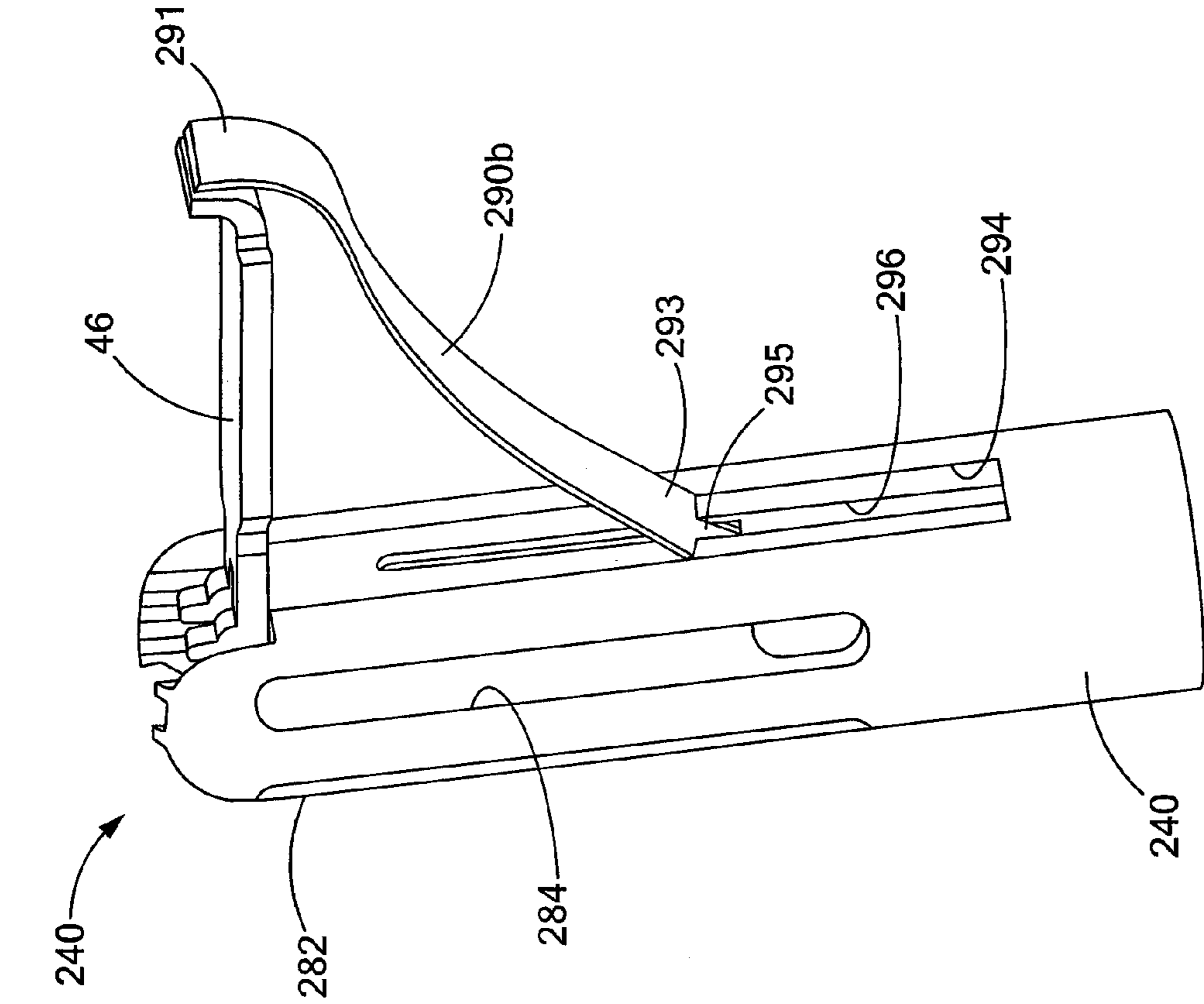

FIG. 24

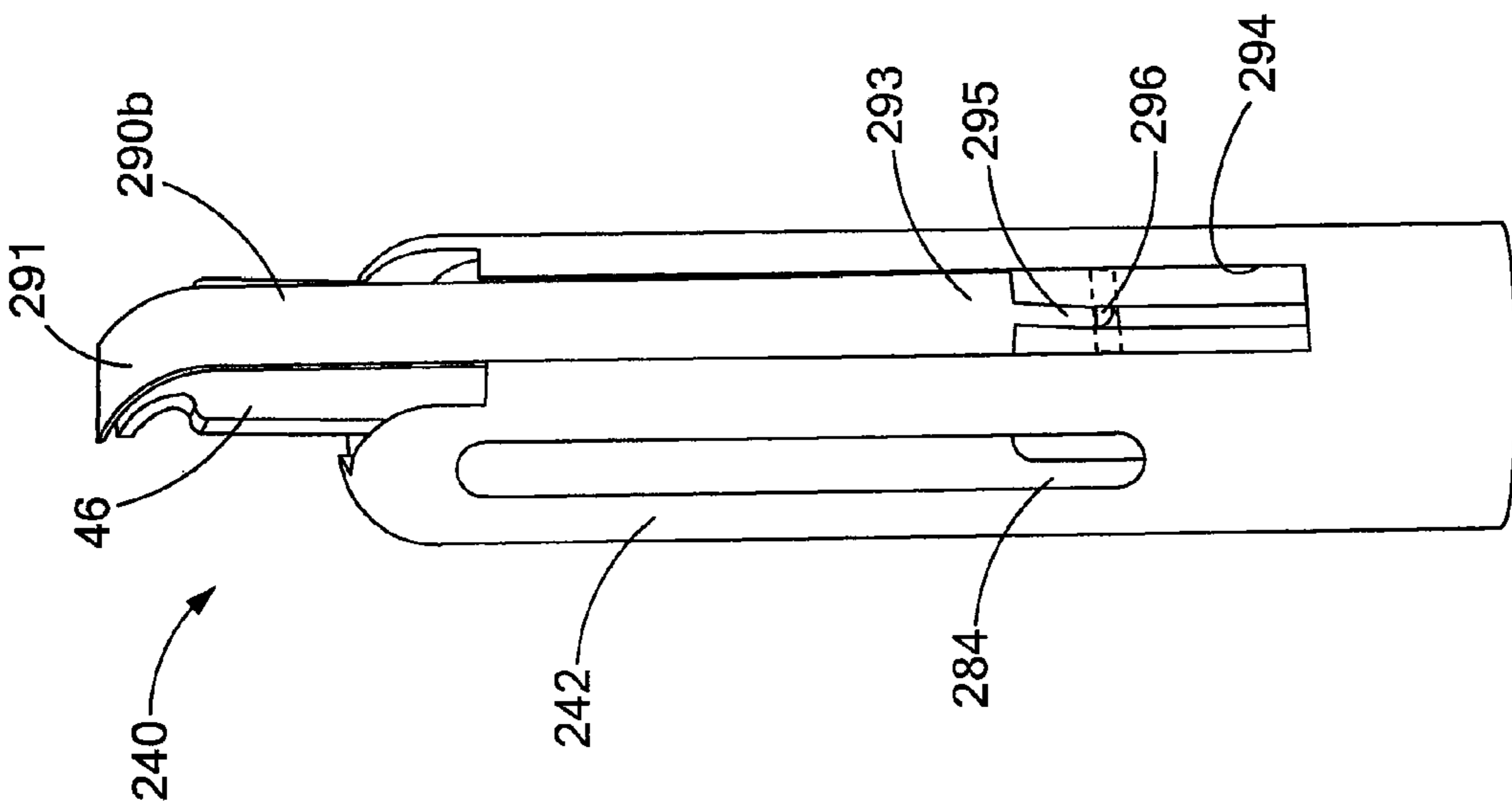

FIG. 25

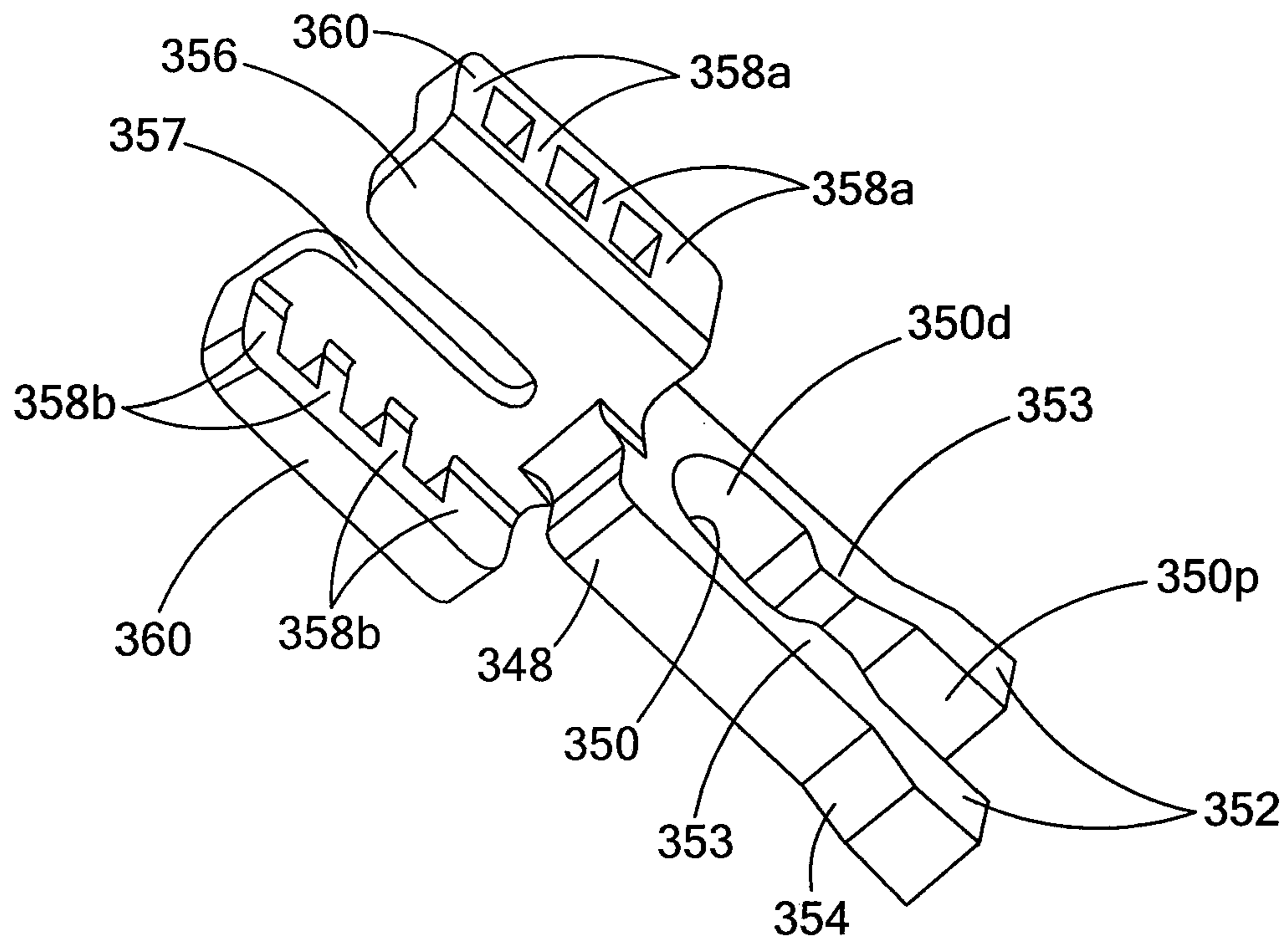

FIG. 26

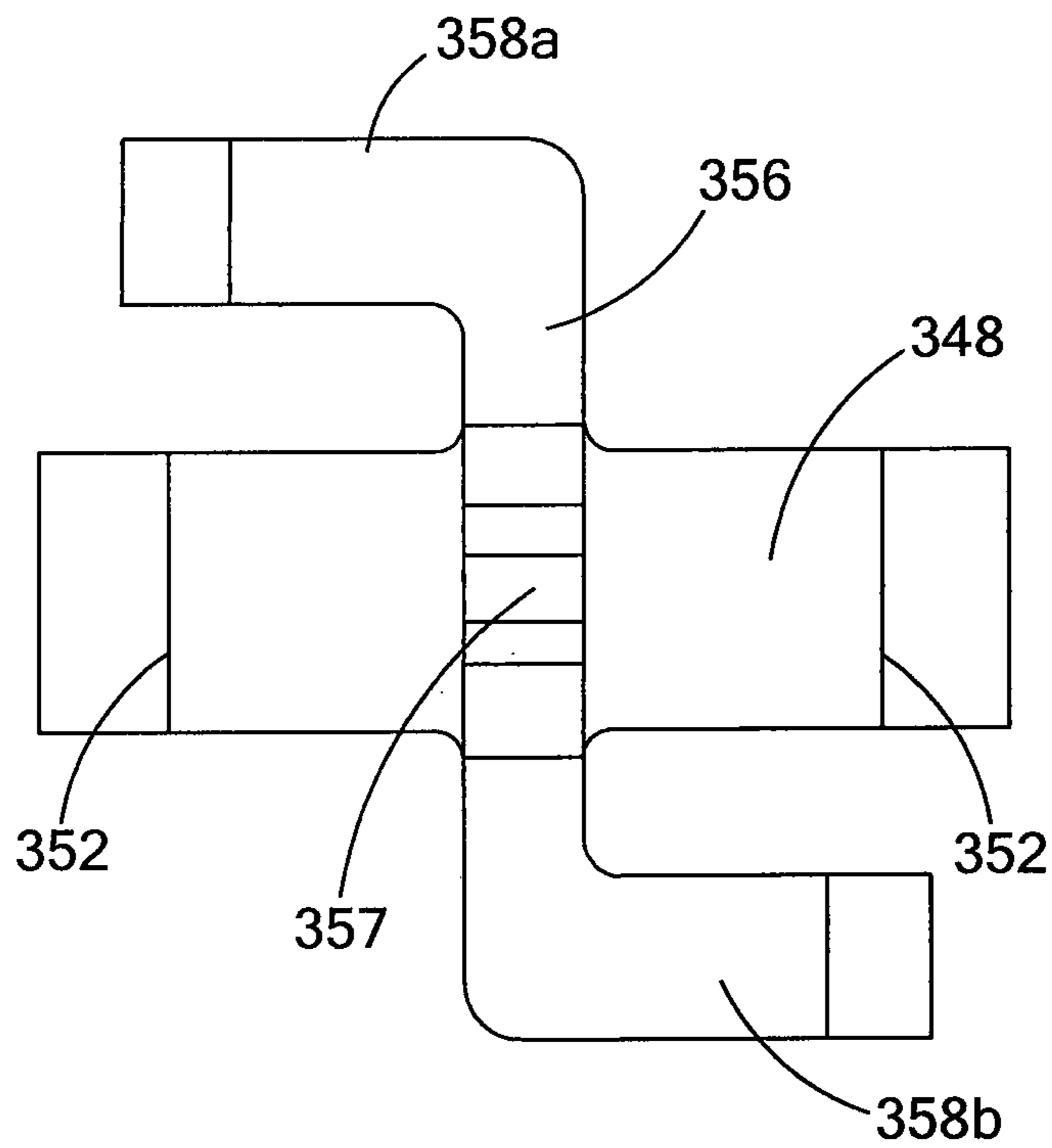

FIG. 27

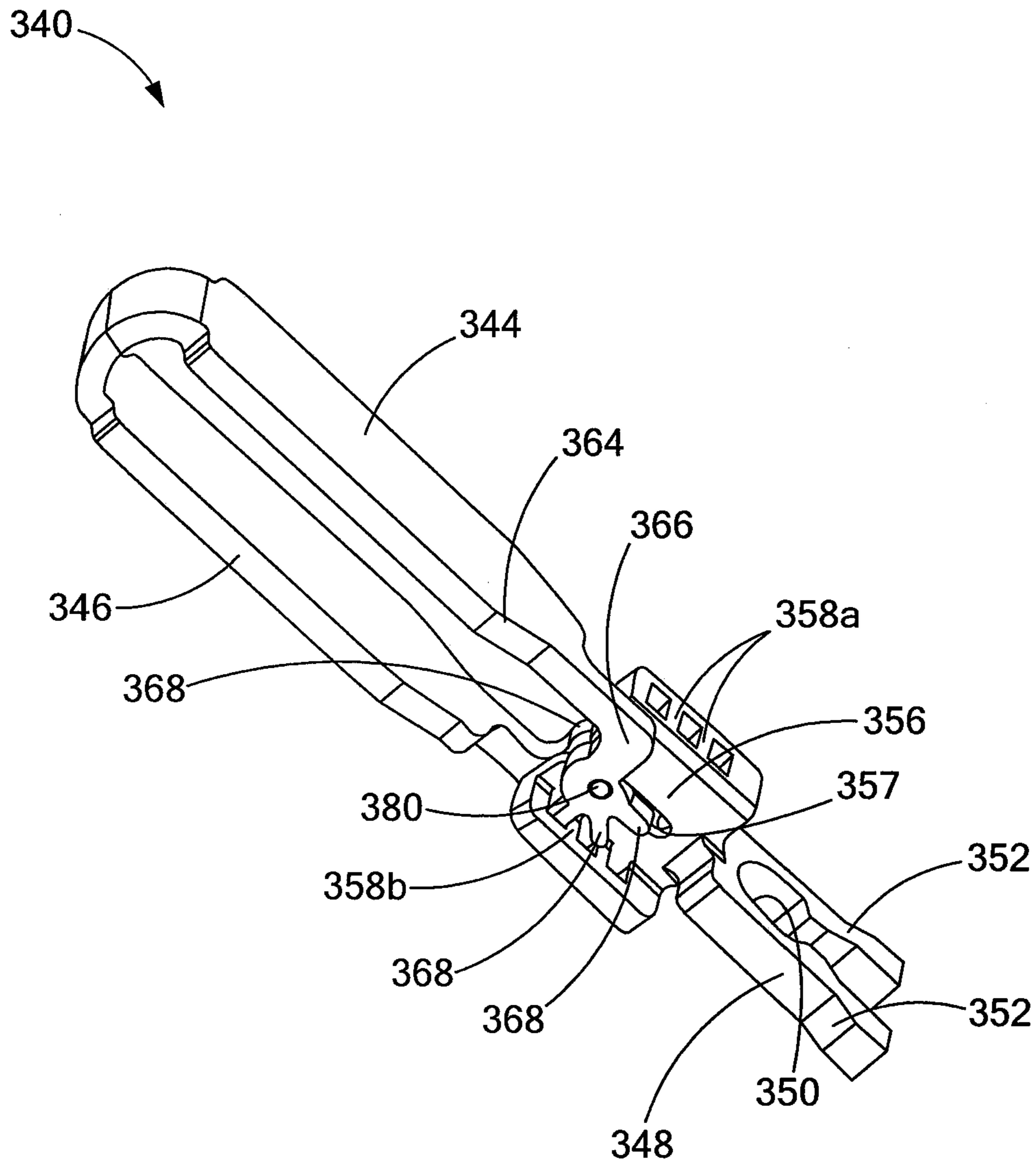

FIG. 28

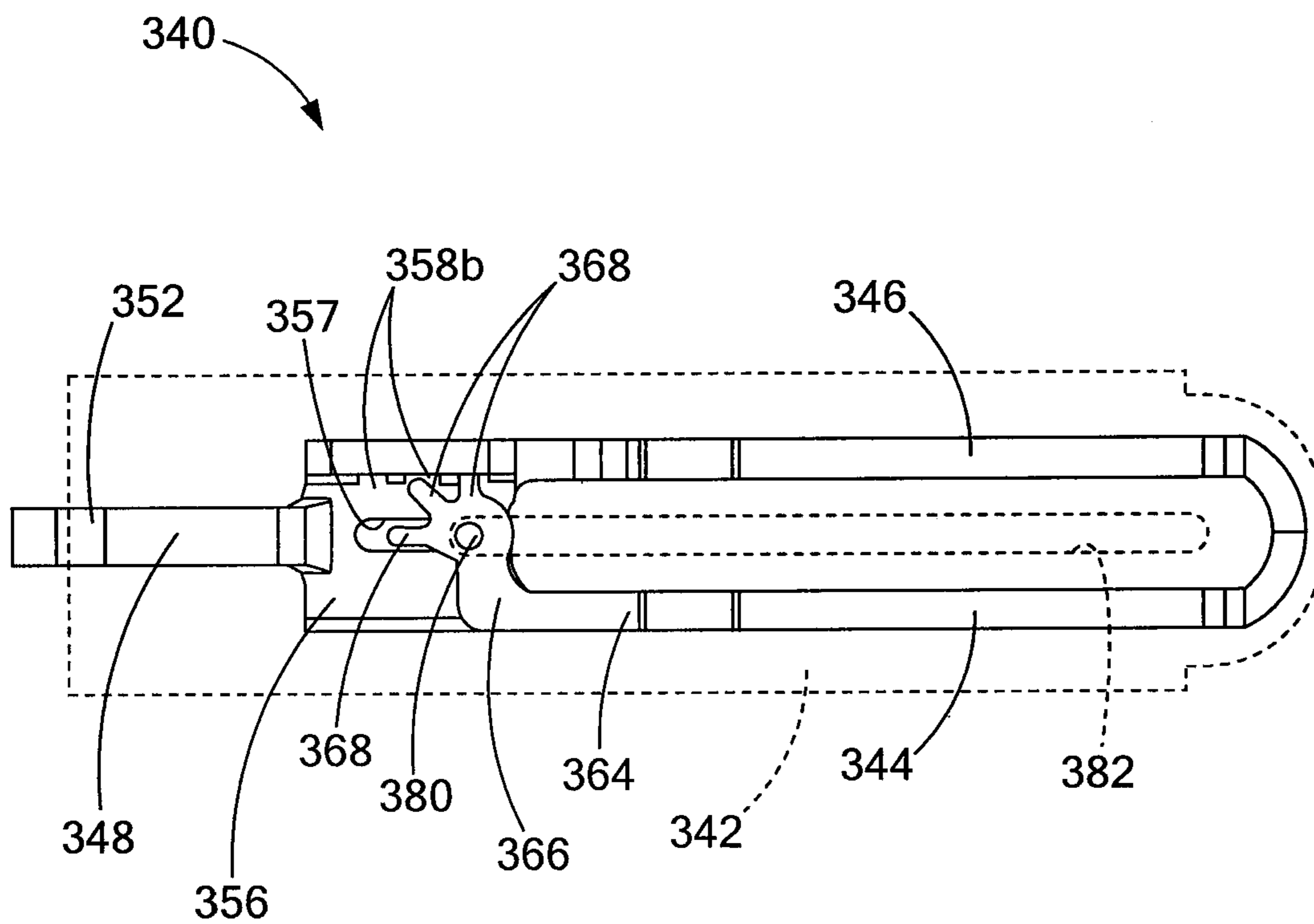

FIG. 29

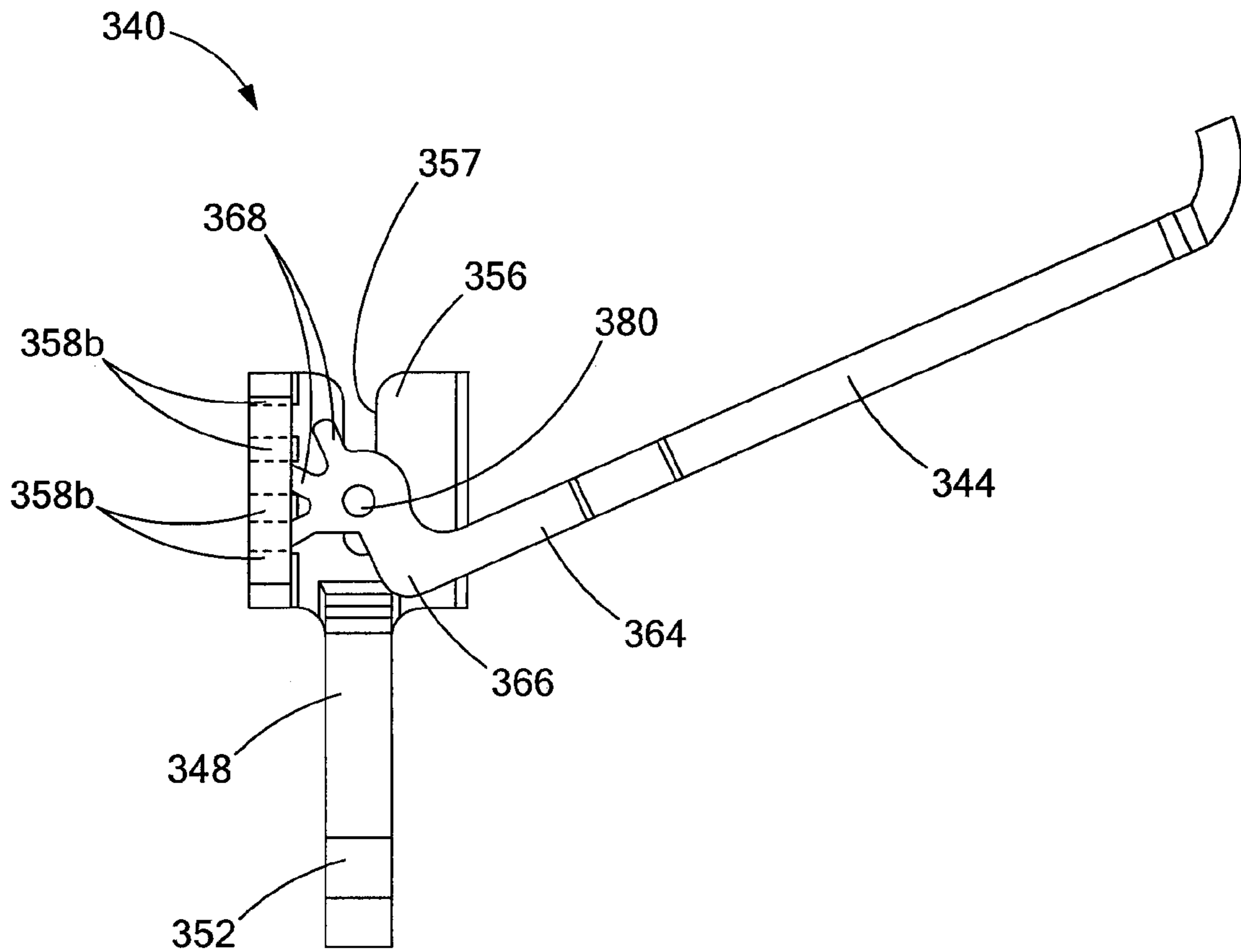

FIG. 30

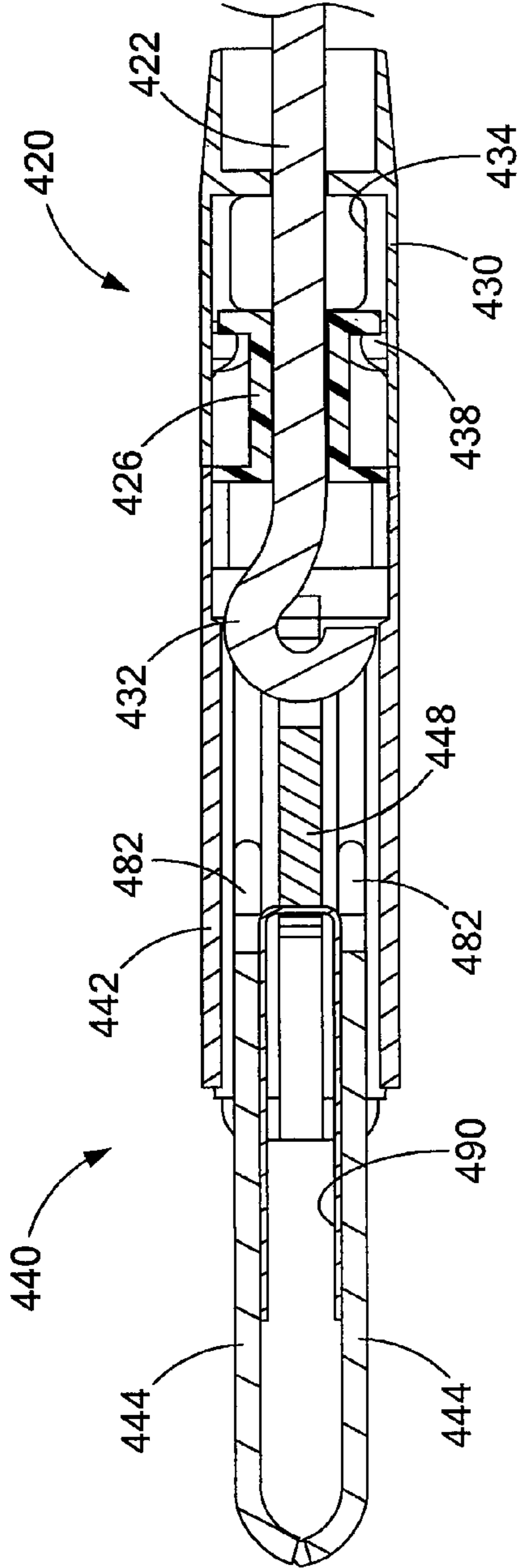

FIG. 31

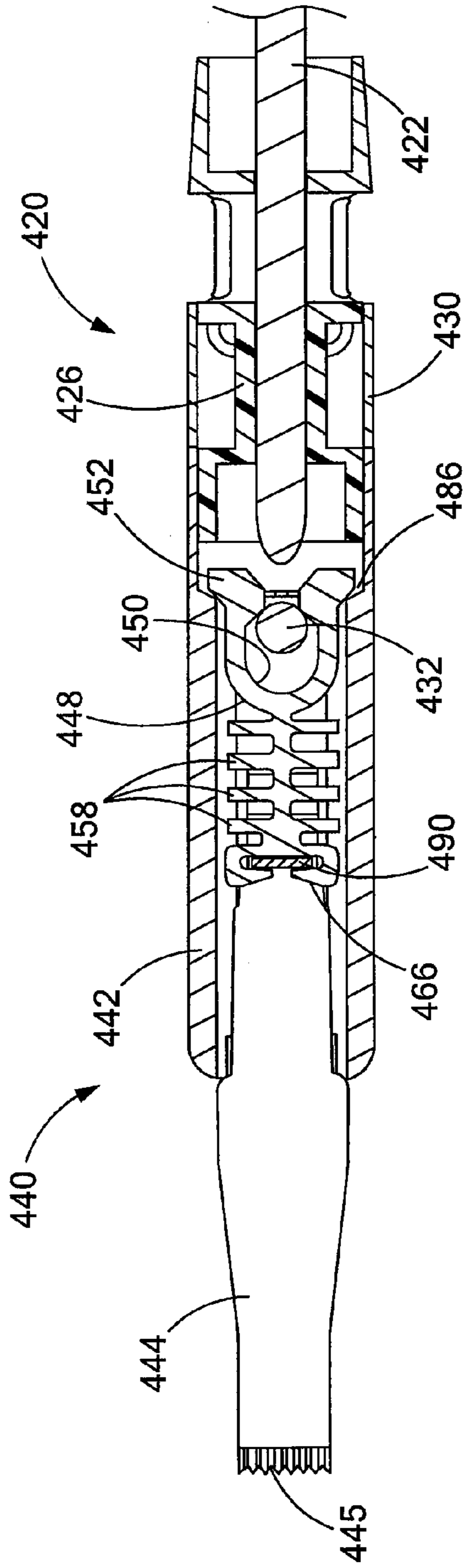

FIG. 32

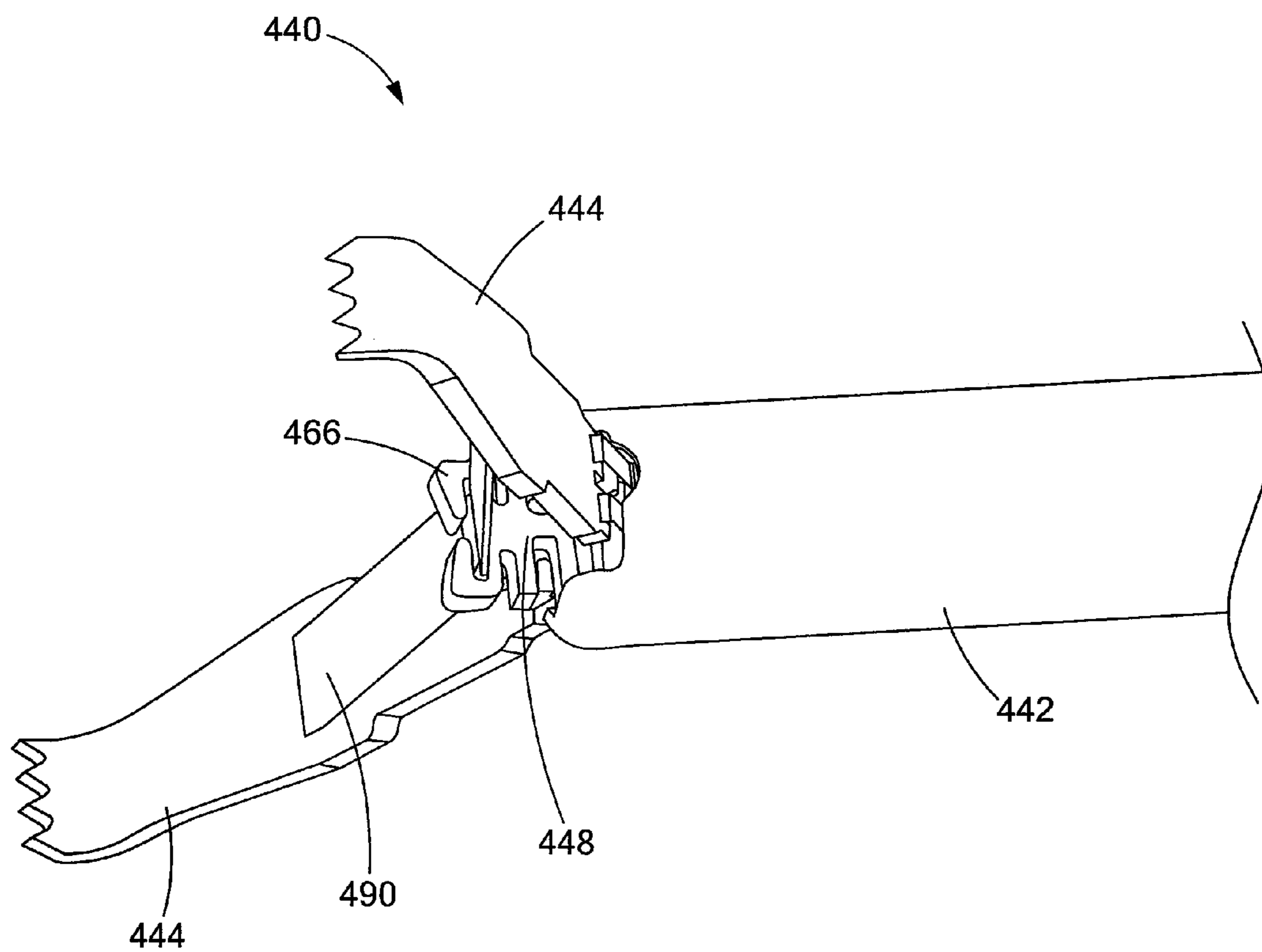

FIG. 33

MEDICAL DEVICES WITH DETACHABLE PIVOTABLE JAWS

CROSS-REFERENCE TO RELATED APPLICATIONS

This application is a Continuation-In-Part of U.S. patent application Ser. No. 12/971,873 filed on Dec. 17, 2010 now U.S. Pat. No. 8,771,293. This application also claims the benefit of U.S. Provisional Patent Application Ser. No. 61/391,881 filed on Oct. 11, 2010. All of the foregoing applications are hereby incorporated by reference.

BACKGROUND

Conventionally, a clip may be introduced into a body cavity through an endoscope to grasp living tissue of a body cavity for hemostasis, marking, and/or ligating. Such clips are often known as surgical clips, endoscopic clips, hemostasis clips and vascular clips. In addition, clips are now being used in a number of applications related to gastrointestinal bleeding such as peptic ulcers, Mallory-Weiss tears, Dieulafoy's lesions, angiomas, post-papillotomy bleeding, and small varices with active bleeding. Clips have also been attempted for use in closing perforations in the stomach

Gastrointestinal bleeding is a somewhat common and serious condition that is often fatal if left untreated. This problem has prompted the development of a number of endoscopic therapeutic approaches to achieve hemostasis such as the injection of sclerosing agents and contact thermo-coagulation techniques. Although such approaches are often effective, bleeding continues for many patients and corrective surgery therefore becomes necessary. Because surgery is an invasive technique that is associated with a high morbidity rate and many other undesirable side effects, there exists a need for highly effective, less invasive procedures.

Mechanical hemostatic devices such as clips have been used in various parts of the body, including gastrointestinal applications. One of the problems associated with conventional hemostatic devices and clips, however, is that many devices are not strong enough to cause permanent hemostasis. Further, clips have also been attempted for use in closing perforations in the stomach or gastrointestinal structures, but unfortunately traditional clips suffer from difficult placement and the capability to grasp a limited amount of tissue, potentially resulting in incomplete closure.

SUMMARY

The invention may include any of the following aspects in various combinations and may also include any other aspect described below in the written description or in the attached drawings.

In a first aspect, a medical device is provided for engaging tissue, the medical device including a housing, first and second jaws, a jaw pin and a driver. The housing defines an internal passageway and a longitudinal axis extending between proximal and distal ends of the housing. The housing also defines a jaw guide surface along the internal passageway, the jaw guide surface having a distal end. The first and second jaws have a proximal end slidably and pivotally connected to the housing, and are slidably received within the internal passageway for longitudinal movement along the jaw guide surface between an extended position and a retracted position. The jaw pin extends through the proximal ends of both the first and second jaws, and engages the jaw guide surface of the housing. The driver is engaged with the proximal

mal ends of the first and second jaws, whereby longitudinal movement of the driver moves the first and second jaws longitudinally along the jaw guide surface between their retracted and extended positions. Longitudinal movement of the driver also rotates the first and second jaws relative to the housing when the first and second jaws are in their extended positions.

According to more detailed aspects, the jaw pin engages the distal end of the jaw guide surface when the first and second jaws are in their extended positions. The proximal ends of the first and second jaws include gears having teeth, and the driver includes corresponding teeth that mesh with the teeth of the jaws. The proximal ends of the first and second jaws are formed as pinions, and the driver is formed as a rack, whereby longitudinal movement of the driver and rack rotates the pinions and first and second jaws in their extended positions. The driver includes a central spine extending longitudinally and teeth extending in laterally opposite directions from the spine to form two sets of teeth, one of the two sets of teeth engaged with the pinion of the first jaw, the other of the two sets of teeth engaged with the pinion of the second jaw. In one embodiment, the driver includes a central plate having first and second ends, and a first set of teeth extend laterally from the first end of the central plate and a second set of teeth extend laterally from the second end of the central plate, the first and second sets of teeth extending in laterally opposite directions. The central plate preferably extends in a plane parallel to the longitudinal axis, and may include a slot extending through a distal end of the plate, the slot sized and positioned to receive the jaw pin. A cross-section of the central plate and sets of teeth, in a plane perpendicular to the longitudinal axis, forms a Z-shape.

In a second aspect, a medical device is provided for engaging tissue, the medical device including a housing, first and second jaws, a driver, and a drive wire. The housing defines an internal passageway and a longitudinal axis extending between proximal and distal ends of the housing. The first and second jaws are rotatable relative to the housing, and have proximal and distal ends. The driver is engaged with the proximal ends of the first and second jaws, whereby longitudinal movement of the driver rotates the first and second jaws relative to the housing. The driver includes two locking tabs forming a socket facing proximally, and is constructed of a material that plastically deforms to adjust the size of the socket. The elongated drive wire is selectively connected to the driver for longitudinal movement therewith. The drive wire has an enlarged portion proximate a distal end of the drive wire and the socket receives the enlarged portion of the drive wire.

According to more detailed aspects, proximal withdrawal of the enlarged portion from the socket causes the driver to plastically deform and the locking tabs to move laterally outwardly. The housing includes a guide surface guiding the longitudinal movement of the driver, and the guide surface includes two surfaces on opposing sides of the housing corresponding to the two locking tabs. The guide surface also preferably includes a proximal portion, a distal portion and a shoulder at the transition between of the proximal and distal portions. The shoulder faces proximally, whereby the locking tabs are positioned to engage the shoulder to limit longitudinal movement of the driver after they have been moved laterally outwardly by the enlarged portion of the drive wire.

In a third aspect, a medical device is provided for engaging tissue, the medical device including a housing, first and second jaws, a driver, a biasing strip, and a drive wire. The housing defines an internal passageway and a longitudinal axis extending between proximal and distal ends of the hous-

ing. The first and second jaws are rotatable relative to the housing, and have proximal and distal ends. The driver is engaged with the proximal ends of the first and second jaws, whereby longitudinal movement of the driver rotates the first and second jaws relative to the housing. The biasing strip is operatively connected to at least one of the first and second jaws to bias the jaws radially. The elongated drive wire is selectively connected to the driver for longitudinal movement therewith.

According to more detailed aspects, a first end of the biasing strip engages the first jaw and a second end of the biasing strip engages the second jaw. A middle portion of the biasing strip is fixed to a distal end of the driver and moves therewith. In another embodiment, the biasing strip is a first biasing strip and the device also includes a second biasing strip. The first biasing strip has one end fixed to the first jaw and the other end slidably attached to the housing. Likewise, the second biasing strip has one end fixed to the second jaw and the other end slidably attached to the housing. Here, an exterior of the housing includes first and second channels sized to receive the first and second biasing strips. The first and second biasing strips are fixed to the distal ends of the first and second jaws, respectively.

BRIEF DESCRIPTION OF THE DRAWINGS

The accompanying drawings incorporated in and forming a part of the specification illustrate several aspects of the present invention, and together with the description serve to explain the principles of the invention. In the drawings:

FIG. 1 is a top view of a medical system having a medical device for engaging tissue, constructed in accordance with the teachings of the present invention;

FIG. 2 is a top view similar to FIG. 1, but showing the outer structures in dotted lines and the interior sections in solid lines and partial cross section;

FIG. 3 is a side view of the medical system and device depicted in FIG. 1;

FIG. 4 is a side view similar to FIG. 3, but showing the outer structures in dotted lines and the interior structures in solid lines and partial cross section

FIG. 5 is a side view of a medical device that is part of the medical system depicted in FIGS. 1-4;

FIG. 6 is a front view of a housing forming a portion of the medical system and device depicted in FIGS. 1-5;

FIG. 7 is a perspective view of the housing depicted in FIG. 6;

FIGS. 8-12 are side views showing operation of the medical system and device depicted in FIGS. 1-5;

FIGS. 13 and 14 are top views, partially in cross-section, depicting operation of the medical system and device depicted in FIGS. 1-4;

FIGS. 15 and 16 are cross-sectional views showing operation of the medical system and device depicted in FIGS. 1-4.

FIGS. 17 and 18 are a perspective view of an alternate embodiment of a grasping jaw forming a portion of the medical system and device of FIG. 1;

FIG. 19 is a plan view of an alternate embodiment of a driver forming a portion of the medical system and device of FIG. 1;

FIG. 20 is a perspective view of the driver of FIG. 19 shown attached to a drive wire;

FIG. 21 is a side view of FIG. 20;

FIG. 22a is a plan view of an alternate embodiment of the medical device of FIG. 1, and FIG. 22b is a plan view of the driver of FIG. 19 shown attached to a strip and forming a portion of the medical device of FIG. 22a;

FIG. 23 is a plane view of another alternate embodiment of the medical device depicted in FIG. 1;

FIGS. 24 and 25 are a perspective views showing operation of the medical device depicted in FIG. 23;

FIGS. 26 and 27 are perspective and end views, respectively, of another embodiment of a driver forming a portion of the medical system and device depicted in FIG. 1;

FIG. 28 is a perspective view of the driver of FIGS. 25-26 shown attached to the jaws;

FIGS. 29 and 30 are plan views showing operation of the driver and jaws depicted in FIG. 28;

FIGS. 31 and 32 are cross-sectional views of another embodiment of the medical system and device depicted in FIG. 1; and

FIG. 33 is a perspective view of the medical system and device depicted in FIGS. 31 and 32.

DETAILED DESCRIPTION

The terms “proximal” and “distal” as used herein are intended to have a reference point relative to the user. Specifically, throughout the specification, the terms “distal” and “distally” shall denote a position, direction, or orientation that is generally away from the user, and the terms “proximal” and “proximally” shall denote a position, direction, or orientation that is generally towards the user.

An exemplary medical system 20 having a medical device 40 for engaging tissue T (FIG. 11) is shown in FIGS. 1 through 4. The medical system 20 and device 40 are generally sized and structured for operation through the working channel of an endoscope (not shown) or other scope, although the system 20 and device 40 may also be used alone or in conjunction with other elongate devices such as catheters, fiberoptic visualization systems, needles and the like. Generally, the medical system 20 includes a drive wire 22 slidably housed within the distal end 23 of an elongated catheter 24 for selective connection to, and operation of, the medical device 40. As will be described in further detail herein, the medical device 40 generally includes a housing 42 having a first jaw 44 and a second jaw 46 pivotally connected thereto for engaging the tissue T. Generally, the jaws 44, 46 have been shown as forming grasping forceps, although the jaws are intended to be used to clip tissue, e.g. to close an opening or for hemostasis. Accordingly, it will be recognized that the shape and structure of the jaws may take many forms and serve many purposes and functions, all in accordance with the teachings of the present invention.

In the medical system 20, the drive wire 22 slidably extends through the catheter 24. Although the term “wire” is used to refer to the drive wire 22, it will be recognized that any elongate control member capable of transmitting longitudinal force over a distance (such as is required in typical endoscopic, laparoscopic and similar procedures) may be used, and this includes plastic rods or tubes, single filament or multi-filament wires, metal rods and the like. The drive wire 22 should also be capable of properly transmitting a rotational/torsional force from the proximal end to the distal end to rotate the medical device 40 and jaws 44, 46, and thus it is currently preferred that the drive wire 22 is formed from nitinol (e.g. a nitinol wire) or other superelastic alloy. A connection block 26 is slidably fitted within the distal end 23 of the catheter 24 and defines a bore 28 therethrough which slidably receives the drive wire 22. The exterior of the connection block 26 includes a recessed portion 27, and two pins 30 (e.g., formed from stainless steel wire) are connected to the catheter 24 and positioned within the recessed portion 27 to limit the longitudinal movement of the connection block 26.

A distal end of the drive wire 22 defines a distal head 32 that is sized larger than the drive wire 22, and likewise larger than the bore 28 in the connection block 26. As will be described later herein, the distal head 32 is used to slide the connection block 26 within the catheter 24 to disconnect the medical device 40 from the medical system 20. As also seen in FIGS. 1-4, the housing 42 of the medical device 40 is a tubular member defining an interior space 43. A proximal end of the housing 42 frictionally receives a distal end of the connection block 26 within the interior space 43 for selective connection therewith.

The internal passageway 43 of the housing 42 also receives the first and second jaws 44, 46 and a driver 48 which is used to interconnect the drive wire 22 to the jaws 44, 46. As best seen in FIGS. 1, 2 and 5, the driver 48 has a proximal portion which defines a socket 50 sized to receive enlarged distal head 32 of the drive wire 22. At the proximal entrance of the socket 50, two deflectable locking tabs 52 are formed which rotate relative to the remainder of the driver 48 to increase or decrease the size of the socket 50. The locking tabs 52 may be separately formed and pivotally attached to the driver 48, or may be integrally formed with the driver 48 and formed of a resilient material which flexes to permit rotation of the locking tabs 52 radially inwardly and radially outwardly. A distal portion of the driver 48 defines a rack 54 for engaging and operating the jaws 44, 46. In the depicted embodiment, the rack 54 includes a central spine 56 having teeth 58 projecting away from the central spine 56 and on opposite sides of the spine 56. One set of teeth 58 on one side of the spine 56 generally operate the first jaw 44 while the other set of teeth 58 on the other side of the spine 56 operate the second jaw 46. It will be recognized that the rack 54 may include a single set of teeth or other geared structures that interface with the jaws 44, 46.

As best seen in FIG. 5, the first and second jaws 44, 46 include distal ends 60, 62 that are structured to grasp and engage tissue, generally they have a talon shape as disclosed in 61/141,934 filed Dec. 31, 2008, the disclosure of which is incorporated herein by reference in its entirety. The proximal ends 64, 66 of the first and second jaws 44, 46 each include a pinion gear 68, 70 having a series of teeth. The teeth of the pinion 68, 70 mesh with the teeth of the rack 54 of the driver 48 such that longitudinal translation of the driver 48 induces rotation in the first and second jaws 44, 46 relative to one another. Generally, distal translation of the driver 48 causes the first and second jaws 44, 46 to rotate outwardly away from each other, while proximal retraction of the driver 48 causes the first and second jaws 44, 46 to rotate inwardly toward one another. Pins 80 are fitted through each the proximal ends of the jaws 44, 46, to pivotally connect the jaws to the housing 42. Other structures for forming a pivotal connection may be used, and preferably the pivotal connection is centrally arranged relative to the pinions 68, 70.

In addition to the jaws 44, 46 being pivotally attached to the housing 42, the first and second jaws 44, 46 are also slidably attached to the housing 42. As best seen in FIGS. 6 and 7 (and in conjunction with FIGS. 1-4) the housing 42 defines a first guide surface 82 for the first jaw 44, and a second guide surface 84 for the second jaw 46. As seen in FIG. 3, the first and second guide surfaces 82, 84 are formed by elongated slots 82a, 82b, 84a, 84b formed in opposing sides of the housing 42 which leaves a thickness of the housing 42 exposed to serve as the guide surface. The slots 82a, 82b are aligned to receive the connecting pin 80 of the first jaw 44, and likewise the slots 84a, 84b are aligned to receive the connecting pin 80 of the second jaw 46. The ends of the slots, for example distal ends 92, 94 shown in FIG. 7, serve to restrict

the longitudinal movement of the jaws 44, 46 relative to the housing 42. The proximal ends 64, 66 of the jaws 44, 46 include apertures 72, 74 which receive the pins 80 (FIGS. 1, 2 and 3) that are used to slidably and pivotally connect the first and second jaws 44, 46 to the housing 42.

It can also be seen in FIGS. 6 and 7 that the housing 42 defines a third guide surface 86 which guides the longitudinal movement of the driver 48 within the housing 42. The guide surface 86 in the depicted embodiment includes a left guide surface 86a and a right guide surface 86b formed as C-shaped channels. As shown in FIG. 7, the third guide surface 86 transitions from a smaller proximal width to a larger distal width to define a shoulder 88 at the transition, which will be further described hereinbelow with reference to FIGS. 13 and 14.

As also shown in FIG. 6, the internal passageway 43 of the housing 42 extends through the distal end of the housing, and through which the first and second jaws 44, 46 can extend. Additionally, as shown in FIGS. 1 and 2, the housing 42 defines opposing slots 45 which are sized to permit the first and second jaws 44, 46 to pass therethrough when they rotate radially outwardly. Accordingly, it is also clear from FIGS. 1 and 2 that the housing 42 serves to block rotation of the first and second jaws 44, 46 when they are entirely or partially contained within the internal passageway 43 of the housing 42. Suitable plastics for forming the housing include, but are not limited to, polytetrafluorethylene (PTFE), expanded polytetrafluorethylene (EPTFE), polyethylene ether keytone (PEEK), polyvinylchloride (PVC), polycarbonate (PC), polyamide, polyimide, polyurethane, polyethylene (high, medium or low density), and suitable metals include stainless steel, nitinol and similar medical grade metals and alloys.

Operation of the medical device 40 will now be described with reference to FIGS. 8-12. As shown in FIG. 8, the first and second jaws 44, 46 are shown in a retracted position where they are substantially contained within the housing 42. Depending on the application, the distal ends 60, 62 of the jaws 44, 46 may slightly project from the distal end of the housing 42 in their retracted positions, or they may be entirely positioned within the housing 42. When the drive wire 22 is translated distally (to the right on the page in FIG. 8) the distal head 32 engages the driver 48, the driver 48 and jaws 44, 46 slide distally through the housing 42. The driver 48 and jaws 44, 46 slide longitudinally before they rotate (even though the rack 54 of the driver 48 is meshed with the pinions 68, 70 at the proximal ends 64, 66 of the jaws 44, 46) since the resistance to longitudinal movement is less than the force required to rotate the jaws 44, 46 (alternatively, the housing 42 can block rotation of the jaws 44, 46 when they are within the housing 42). As previously mentioned, this longitudinal movement is guided by the first and second guide surfaces 82, 84 which receive the pins 80 that slidably and pivotally connect the jaws 44, 46 to the housing 42.

As shown in FIG. 9, the first and second jaws 44, 46 have an extended position where the jaws substantially project from a distal end of the housing 42, and their proximal ends 64, 66 are positioned adjacent the distal end of the housing 42. Accordingly, it will be seen that further distal advancement of drive wire 22, and hence the driver 48, causes the pinion 68 to rotate over the teeth 58 of the rack 54. As best seen in FIG. 10, the first and second jaws 44, 46 rotate radially outwardly from each other into a tissue receiving position. Notably, due to the presence of slots 45 at the distal end of the housing 42, the jaws 44, 46 are permitted to rotate a full 90°, thus forming at least a 180° between them. It will be recognized that through the sizing of the slots 45 and the construction of the rack 54

and pinions 68, 70, the first and second jaws 44, 46 may rotate even further away from each other.

In the tissue receiving configuration shown in FIG. 10, the medical device 40 and its jaws 44, 46 may be positioned adjacent tissue T. As shown in FIG. 11, the tissue T may be placed between the first and second jaws 44, 46 and the jaws 44, 46 rotated back towards their position shown in FIG. 9. The tissue T has been shown as a single layer, although multiple layers may be clipped between the jaws 44, 46. Generally, proximal retraction of the drive wire 22 and the driver 48 again causes rotation of the first and second jaws 44, 46 to grasp the tissue T therebetween. As shown in FIG. 12, further proximal retraction of the drive wire 22 and driver 48 will cause the jaws 44, 46 to move longitudinally in a proximal direction (to the left on the page in FIG. 12).

In order for the medical device 40 to serve as a clip and maintain its grasp on the tissue T, or to maintain the clipping of two layers of tissue against each other, the jaws 44, 46 may be locked in position and the drive wire 22 of the medical system 20 disconnected from the medical device 40. As shown in FIG. 13, the third guide surface 86 (which guides the driver 48) includes a proximal portion 86p and a distal portion 86d. The proximal portion 86p of the third guide surface 86 has a width (measured up and down on the page in FIG. 13) that is greater than a width of the distal portion 86d of the third guide 86. As previously discussed, the third guide surface 86 is formed by opposing surfaces or C-shaped channels 86a, 86b of the housing 42. The transition between the proximal portion 86p and distal portion 86d defines a shoulder 88, and namely two shoulders 88a, 88b on opposing sides of the housing 42. The shoulders 88a, 88b are sized and positioned to engage the locking tabs 52 located on the driver 48.

As shown in FIG. 13, when the driver 48 is located within the distal portion 86d of the third guide surface 86, the locking tabs 52 are forced radially inwardly into firm frictional engagement with the drive wire 22. Stated another way, the socket 50 formed by the driver 48 to receive the distal head 32 has an entrance which is narrowed by the inward deflection of the locking tabs 52. Preferably, the locking tabs 52 plastically deform rather than elastically deform, and the tabs 52 may be bent inwardly around the distal head 32 during initial assembly of the device, and thus sized for the distal portion 86d of the third guide surface 86. In this state depicted in FIG. 13, the drive wire 22 is firmly engaged with the driver 48 and hence the first and second jaws 44, 46.

When the drive wire 22 and driver 48 are retracted proximally, for example upon grasping tissue as shown in FIG. 12, the proximal end of the driver 48 is received within the proximal portion 86p of the third guide surface 86 which has a larger width that permits radially outward movement of the locking tabs 52. Accordingly, in the state depicted in FIG. 14, the locking tabs 52 may be loosely and detachably connected to the distal head 32 of the drive wire 22. That is, the proximal retraction of the jaws 44, 46 will be limited by either the tissue T engaging the distal end of the housing 42, or the pins 80 will abut the proximal ends of the slots 82a, 82b, 84a, 84b defining a first and second guide surfaces 82, 84. As such, when proximal movement of the jaws 44, 46 and the driver 48 are thus limited, further proximal movement of the drive wire 22 and its distal head 32 may be used to withdraw the distal head 32 from the socket 50 of the driver 48. This operation may also be used to further deflect the locking tabs 52 radially outwardly. An appropriate amount of proximally directed force on the drive wire 22 causes the distal head 32 to move proximally through the locking tabs 52 and plastically deform them radially outwardly. In the event the natural elasticity of the tissue T tends to pull the jaws 44, 46 out from the housing

towards their extended position, the locking tabs 52, 54 will abut the shoulders 88a, 88b of the third guide surface of the housing 42 to prevent further distal movement of the jaws 44, 46.

Turning now to FIGS. 15 and 16, upon still further proximal retraction of the drive wire 22 and distal head 32, the enlarged distal head 32 will abut the connection block 26 which is slidably fitted within the distal end 23 of the catheter 24. Sufficient proximal force on the drive wire 22 will overcome the frictional fit between the connection block 26 and the proximal end of the housing 42, thus moving the connection block 26 proximally (to the right on the page of FIGS. 15 and 16) to retract the connection block 26 within the tubular connector 24, as shown in FIG. 16. The catheter 24 can be used to provide a counterforce on the housing 42 while proximally retracting the drive wire 22 and connection block 26. Accordingly, the drive wire 22, catheter 24 and connection block 26 may be fully disconnected from the medical device 40, thereby leaving the first and second jaws 44, 46 and the housing 42 in a state having the tissue T clipped between the jaws 44, 46 and retained in vivo. The connection block 26 is retained at the distal end 24 of the catheter 24 via the pins 30, which are positioned within the recessed area 27 to engage the proximal and distal ends of the connection block 26 and limit its longitudinal movement.

The elongated catheter 24 (or other elongate tubular member such as a sheath, tube, scope or the like), which slidably encases the drive wire 22, extends proximally therealong to a proximal end of the system 20, and has a length suitable for placing the device 40 at any desired location within the body, while the proximal ends of drive wire 22 and catheter 24 are positioned outside of the body for use by the medical professional. Control handles (not shown) for controlling relative translation of the drive wire 22 and catheter 24 are well known in the art, and may be employed at the proximal end of the system 20.

Another embodiment and method of forming the grasping jaws 44, 46 are shown in FIGS. 17-18. The jaws of the prior embodiment were generally machined, however the jaws 44, 46 may also be formed by stamping. A flat piece of metal preferably of medical grade stainless steel, is stamped into the shape 144 shown in FIG. 17. The shape includes a slightly narrow distal end 160 which then can be bent into the shape shown in FIG. 18 for grasping and engaging tissue. The distal end 160 may also be stamped to include a serrated edge, or other shapes or edge features depending upon the application. The proximal end 164 generally includes two arms 166 which lead to gears 168. As shown in FIG. 18, the gears 168 are grasped and then rotated about 90 degrees such that the gears 168 extend in a plane that is perpendicular to the plane of the sheet 144. The gears 168 also include a through-hole 172 for receiving a guiding pin. It will also be recognized that the jaws 44, 46 in this embodiment may also be formed of a single arm 166 and single gear 168.

Another embodiment of a driver 148 and drive wire 122 are shown in FIGS. 19-22. The driver 148 generally includes a socket 150 formed by two locking tabs 152. In this embodiment, a proximal portion of the locking tabs define slanted shoulders 154 which slope laterally outwardly for engagement with the third guide surface 86 in the housing 42 as previously discussed. The locking tabs 152 also include inner projections 153 which project laterally inwardly and separate the socket 150 into a distal portion 150d and a proximal portion 150p. The driver 148 again includes a central spine 156 and opposing teeth 158. In this embodiment, the distal end 166 of the driver 148 includes a pocket 168 defined by two inwardly projecting flanges 170, as will be discussed

further herein. The two flanges 170 extend along a distal side of the pocket 168, and leave a gap therebetween for access to the pocket 168.

As seen in FIGS. 20 and 21, this embodiment of the drive wire 122 includes a distal head 132 which is formed by bending the distal end of the drive wire 122 into a semi-circular shape as shown, preferably spanning an arc of 180 degrees to 360 degrees. Accordingly, it can be seen that the distal head 132 defines an opening 133 that is sized to receive the inner projections 153 of the locking tabs 152. As shown, the distal portion 150d of the socket 150 receives the distal-most part of the curved distal head 132, while the proximal portion of the distal head 132 projects through the proximal portion 150p of the socket 150 and proximally away therefrom. As noted above, the locking tabs 152 here are structured to be plastically deformed, and thus after formation and connection to the drive wire 122 as shown in FIG. 19, the tabs 152 are bent radially inwardly to secure the projections 153 within the opening 133 of the socket 132. In this state, the exterior shoulders 154 of the locking tabs 152 are sized to fit within the third guide surface 86, and more particularly the distal portion 86d of the third guide surface 86 without further deformation.

As shown in FIGS. 22a and 22b, another embodiment of the medical device 140 may include the housing 142, grasping arms 144, 146 just as in the prior embodiment, but in this embodiment include the alternate driver 148 and an additional biasing element, namely a biasing strip 190. As best seen in FIG. 22b, the distal end 166 of the driver 148 receives the biasing strip 190 within the pocket 168. The flanges 170 are bent inwardly and proximally as shown to firmly engage the metal strip 190 and fix it to the driver 148. The biasing strip 190 is preferably a thin strip formed from a sheet of resilient material, and more preferably a metal strip, e.g. formed of stainless steel, nitinol or other super elastic alloy that is biocompatible. Accordingly, it will be recognized that as the driver 148 is moved proximally to cause the jaws 144, 146 to close, the biasing strip 190 will be forced into a V-shape or U-shape, as shown by the dotted lines in FIG. 22a. That is, the biasing strip 190 has a straight shape in its natural, unbiased, configuration, and when bent into the V-shape it exerts a radially outward force on the jaws 144, 146. This biasing force provides the jaws 144, 146 with smooth rotation and transition between the open and closed positions. It will also be recognized that the biasing strip 190 could also have its original, unbiased position formed as a V-shape or a U-shape, and be affixed to the jaws 144, 146 such that it exerts a radially inward biasing force. The free ends 192 of the metal strip 190 simply press against the jaws 144, 146, but are not fixed or rigidly attached thereto.

Turning to FIG. 23, another embodiment of the medical device 240 is shown, again including a housing 242 and opposing jaws 244, 246 that are slidably attached thereto. The housing 242 again includes first and second guides 282, 284 for guiding movement of the jaws 244, 246. In this embodiment however, each jaw 244, 246 includes a biasing strip 290a, 290b, respectively. The distal ends 291 of the strips 290a, 290b are fixedly attached to the exterior of the jaws 244, 246, preferably at their distal ends, and preferably by way of an adhesive, soldering, welding, or other known bonding techniques. As best seen in FIGS. 24 and 25, the housing 240 includes two exterior channels 294 on opposite sides of the housing 240 (one being shown in FIGS. 24 and 25) which are sized to receive the resilient strips 290a, 290b such that they are flush with the exterior surface of the housing in the closed/retracted configuration. The proximal ends 293 of the strips 290a, 290b include a T-shaped formed by a base 295 and cross bar 296. The base 295 extends through a smaller slot

296 formed through the housing 240. The slots 296 are coextensive with the channels 294. The cross bar 296 rides along the interior of the housing 240 and maintains the slidable connection between the strips 290 and the housing 240. Accordingly, it can be seen that the proximal ends 293 of the strips 290a, 290b are slidably and pivotably attached to the housing 240 via the channel 294 and its slot 296, allowing the strips 290a, 290b to travel with the grasping jaws 44, 46 as shown between their open and closed positions as shown in FIGS. 24 and 25.

Turning now to FIGS. 26-30, another embodiment of a driver 348 is shown. As best seen in FIGS. 26 and 27, the driver 348 again includes a socket 350 formed by two locking tabs 352 which have inner projections 353 and outer shoulders 354, and which divide the socket 350 into a distal portion 350d and a proximal portion 350p. Unlike the prior embodiments of the driver, in this embodiment the distal portion defines a geared rack that has a Z-shape. Generally, a central plate 356 replaces the central spine 56, 156 of the prior embodiments, and the plate 356 extends in a plane that is parallel to the longitudinal plane of the housing 342 (FIG. 29). The plane of the central plate 356 is also perpendicular to a plane of the proximal half of the driver 348 (i.e. that which includes the socket 350 and tabs 352). A first set of teeth 358a project laterally away from the central plate 356 in a first direction, while a second set of teeth 358b project laterally away from the central plate 356 in a second direction. The first and second sets of teeth 358a, 358b extend from opposite ends of the central plate 356, and the first and second directions are generally opposite each other. The sets of teeth 358a, 358b are each securely held to the central plate 356 by two outer frames 360 which extend around the periphery of the teeth 358a, 358b.

Accordingly, and as best seen in FIG. 28, the medical device 340 includes first and second grasping jaws 344, 346 each having a proximal end 366 and gear teeth 368 which have been bent to project orthogonally away from a main body of the jaw 344. Accordingly, the first set of teeth 358a receive the gear 368 of the second jaw 346, while the second set of teeth 358b receive the gear 368 of the first jaw 344. Notably, having the proximal ends 366 of the jaws 344, 346 bent laterally/orthogonally as shown allows a single pin 380 to be passed through the gears 368 and thus shared by both jaws 344, 346. Still further, and as shown in FIG. 29, the housing 342 may thus include only a single guide surface 382 formed by a single slot on each lateral side of the housing 342 for receiving the ends of the single pin 380. It can be seen that the first and second jaws 344, 346 thereby share a single guide surface 382 (a jaw guide surface) and guide slot, thus ensuring their coordinated operation and smooth opening and closing.

As also shown in FIG. 29, a slot 357 is formed in the central plate 356, and is aligned with the pin 380 and jaw guide surface 382 to receive the pin 380 as the driver 348 moves forwardly relative to the jaws 344, 346. As discussed above and shown in FIG. 30, when the pin 380 (shared by proximal ends 366 and gears 368 of the jaws 344, 346) has hit the distal end of the single jaw guide surface 382, the driver 348 will continue moving distally to cause the gears 368 to rotate via the rack/teeth 358a, 358b of the driver 348, thereby inducing rotation of the jaws 344, 346.

Turning to FIGS. 31-33, another embodiment of the medical system 420 and medical device 440 are depicted. In this embodiment, medical system 420 again includes a drive wire 422 having a distal head 432 which is formed by bending the distal end of the drive wire 422 into the shape shown. The medical system 420 also includes a catheter attachment 430 which is generally a tubular member that is connected to the

distal end of the catheter **24** and is used to slidably receive the connection block **426**. The catheter attachment **430** includes a pair of openings **434** to provide access to the control wire **422** and the connection block **426**, whereby a tool may be used to hold the connection block **426** in either a retracted or extended position, as further described in copending U.S. Appl. No. 61/391,878 filed concurrently herewith, and Appl. No. 61/391,875 filed concurrently herewith, the disclosures of which are hereby incorporated by reference in their entirety.

The medical device **440** includes a housing **442** which is detachably connected to the catheter **24** and its catheter attachment **430** via the connection block **426**. The housing **442** slidably receives the pair of jaws **444** which are connected to the drive wire **422** via the driver **448**. As with the previous embodiments, the driver **448** includes a socket **450** defined by locking tabs **452** which releasably engage the distal head **432** of the drive wire **422**. The distal portion of the driver **448** includes a plurality of teeth **458** which define a gear or rack which serves to drive rotation of the jaws **444** as previously described. The distal end **466** of the driver **448** includes a pocket defined by flanges which are used to fixably engage the biasing strip **490**. The housing **442** further defines a pair of guiding surfaces or slots **482** which guide the longitudinal and rotational movement of the jaws **444**.

In this embodiment, the jaws **444** and housing **442** are structured such that in the fully retracted position (shown), the jaws **444** project (at least partially) out distally from the end of the housing **442**. As best seen in FIG. **32**, as the distal head **432** is pushed through the locking tabs **452** they are plastically deformed outwardly to engage the shoulders **446** in the housing, and the jaws **444** are fully retracted. In this way, the length of the housing **442** can be shortened, as can the guiding slots **482** therein for guiding the jaws **444**. It can also be seen in FIG. **32** that the distal ends of the jaws **444** include serrations **445** or other structures which may aid in gripping tissue.

It is also noted that in this embodiment, as with all prior embodiments, the drive wire **422** is capable of transmitting rotational force and torque (e.g. from the proximal operating end of the system **20/420**) through the distal head **432** and the driver **448** to the jaws **444**. As such the medical device **440** may be rotated via rotation of the drive wire **422**, i.e. the jaws **444**, jaw pins (e.g. **80**), housing **442**, and driver **448** all rotate as a unit relative to the catheter **24**. In as much as the housing **442** may also be non-rotatably connected to the connection block **426** (e.g. depending on the friction therebetween), the connection block **426** may also rotate within the catheter attachment **430** (or the catheter, e.g. **24** when the catheter attachment **430** is not used). Accordingly, the orientation of the jaws **444** may be rotated through rotation of the proximal end of the drive wire **422** to orient the jaws relative to the tissue or material being grasped or clipped. It has been found that forming the drive wire **422** out of a solid nitinol wire has provided good torque transmission for rotation of the medical device **440**.

It has also been found that having the jaws **444** project at least partially out of the housing **442** in their fully retracted position allows the orientation of the jaws **444** to be visualized so that it is easier to rotate the jaws **444** prior to opening and closing them around tissue. Still further, additional tissue may be encapsulated in the jaws **444** before the tissue abuts the distal end of the housing **442**. The distance which the jaws **444** project from the housing **442** may be varied depending upon a particular application, i.e. sized to correspond to the thickness of the tissue or the type of procedure being per-

formed to insure good spacing between the distal ends of the jaws **444** and the distal end of the housing **442**.

The foregoing description of various embodiments of the invention has been presented for purposes of illustration and description. It is not intended to be exhaustive or to limit the invention to the precise embodiments disclosed. Numerous modifications or variations are possible in light of the above teachings. The embodiments discussed were chosen and described to provide the best illustration of the principles of the invention and its practical application to thereby enable one of ordinary skill in the art to utilize the invention in various embodiments and with various modifications as are suited to the particular use contemplated. All such modifications and variations are within the scope of the invention as determined by the appended claims when interpreted in accordance with the breadth to which they are fairly, legally, and equitably entitled.

The invention claimed is:

1. A medical device for engaging tissue, the medical device comprising:

a housing defining an internal passageway and a longitudinal axis extending between proximal and distal ends of the housing, the housing defining a jaw guide surface along the internal passageway, the jaw guide surface having a distal end;

a first jaw having a proximal end slidably and pivotally connected to the housing, the proximal end including a first gear having teeth the first jaw slidably received within the internal passageway for longitudinal movement along the jaw guide surface between an extended position and a retracted position;

a second jaw having a proximal end slidably and pivotally connected to the housing, the proximal end including a second gear having teeth the second jaw slidably received within the internal passageway for longitudinal movement along the jaw guide surface between an extended position and a retracted position;

a jaw pin extending through the proximal ends of both the first and second jaws, the jaw pin engaging the jaw guide surface of the housing; and

a driver having teeth engaged with the teeth of the first and second gears at the proximal ends of the first and second jaws, longitudinal movement of the driver moving the first and second jaws longitudinally along the jaw guide surface between their retracted and extended positions, longitudinal movement of the driver rotating the first and second jaws relative to the housing when the first and second jaws are in their extended positions.

2. The medical device of claim **1**, wherein the jaw pin engages the distal end of the jaw guide surface when the first and second jaws are in their extended positions.

3. The medical device of claim **1**, wherein the proximal ends of the first and second jaws are formed as pinions, and wherein the driver is formed as a rack, wherein longitudinal movement of the driver and rack rotates the pinions and first and second jaws in their extended positions.

4. The medical device of claim **3**, wherein the driver includes a central spine extending longitudinally and teeth extending in laterally opposite directions from the spine to form two sets of teeth, one of the two sets of teeth engaged with the pinion of the first jaw, the other of the two sets of teeth engaged with the pinion of the second jaw.

5. The medical device of claim **3**, wherein the driver includes a central plate having first and second ends, and wherein a first set of teeth extend laterally from the first end of the central plate and a second set of teeth extend laterally from

13

the second end of the central plate, the first and second sets of teeth extending in laterally opposite directions.

6. The medical device of claim 5, wherein the first and second sets of teeth each include a frame extending around the teeth.

7. The medical device of claim 5, wherein the central plate extends in a plane parallel to the longitudinal axis.

8. The medical device of claim 5, wherein the central plate includes a slot extending through a distal end of the plate, the slot sized and positioned to receive the jaw pin.

9. The medical device of claim 5, wherein a cross-section of the central plate and sets of teeth, in a plane perpendicular to the longitudinal axis, forms a Z-shape.

10. A medical device for engaging tissue, the medical device comprising:

a housing defining an internal passageway and a longitudinal axis extending between proximal and distal ends of the housing;

a first jaw rotatable relative to the housing, the first jaw having proximal and distal ends;

a second jaw rotatable relative to the housing, the second jaw having proximal and distal ends;

a driver engaged with the proximal ends of the first and second jaws, longitudinal movement of the driver relative to the first and second jaws driving rotation of the first and second jaws relative to the housing;

14

a biasing strip operatively connected to at least one of the first and second jaws to provide a radially directed biasing force on the first and second jaws, the biasing strip directly attached to the driver; and

an elongated drive wire selectively connected to the driver for longitudinal movement therewith.

11. The medical device of claim 10, wherein the proximal ends of the first and second jaws include gears having teeth, and wherein the driver includes corresponding teeth that mesh with the teeth of the jaws.

12. The medical device of claim 10, wherein a first end of the biasing strip engages the first jaw and a second end of the biasing strip engages the second jaw.

13. The medical device of claim 12, wherein a middle portion of the biasing strip is fixed to a distal end of the driver and moves therewith.

14. The medical device of claim 10, wherein the biasing force is opposed by the driver engaged with the first and second jaws.

15. The medical device of claim 10, wherein the biasing force is directed radially outwardly.

16. The medical device of claim 10, wherein the biasing strip is directly affixed to the driver for movement therewith.

* * * * *