

US009308393B1

(12) **United States Patent**
Olvera

(10) **Patent No.:** **US 9,308,393 B1**
(45) **Date of Patent:** **Apr. 12, 2016**

(54) **BED DRYING DEVICE, UV LIGHTS FOR BEDSORES**

(71) Applicant: **Guadalupe Olvera**, Richland, WA (US)

(72) Inventor: **Guadalupe Olvera**, Richland, WA (US)

(73) Assignee: **DRI-EM, Inc.**, Richland, WA (US)

(*) Notice: Subject to any disclaimer, the term of this patent is extended or adjusted under 35 U.S.C. 154(b) by 0 days.

(21) Appl. No.: **14/598,071**

(22) Filed: **Jan. 15, 2015**

(51) **Int. Cl.**

A61N 5/06 (2006.01)
A61G 7/057 (2006.01)
A61B 19/00 (2006.01)
A47K 10/00 (2006.01)

(52) **U.S. Cl.**

CPC **A61N 5/0624** (2013.01); **A47K 10/00** (2013.01); **A61B 19/26** (2013.01); **A61G 7/057** (2013.01); **A61N 2005/0633** (2013.01); **A61N 2005/0638** (2013.01); **A61N 2005/0661** (2013.01)

(58) **Field of Classification Search**

CPC **A61N 5/062**
USPC **607/88, 89**
See application file for complete search history.

(56) **References Cited**

U.S. PATENT DOCUMENTS

630,565 A 8/1899 Safran
932,024 A 8/1909 Barabas
945,234 A 1/1910 Hindale
1,142,876 A 6/1915 Greenwood
1,334,901 A 3/1920 Higdon
1,643,793 A 3/1926 Sparhawk

1,637,488 A 8/1927 Knopp
1,772,310 A 8/1930 Hart
2,097,751 A 11/1937 Baltich
2,235,966 A 3/1941 Summers
2,437,006 A 3/1948 Simpson
2,491,557 A 12/1949 Goolsbee
2,601,189 A 6/1952 Wales
2,719,986 A 10/1955 Rand
2,731,652 A 1/1956 Bishop
2,782,834 A 2/1957 Vigo
2,897,741 A 8/1959 Mauch
2,938,570 A 5/1960 Flajole
2,977,456 A 3/1961 Murphy
2,998,817 A 9/1961 Armstrong
3,008,465 A 11/1961 Gal
3,012,256 A 12/1961 Zerbee
3,030,145 A 4/1962 Kottemann
3,101,488 A 8/1963 Peebles
3,128,161 A 4/1964 Hudon
3,148,391 A 9/1964 Whitney
3,156,242 A 11/1964 Crowe
3,199,124 A 8/1965 Grant
3,209,380 A 10/1965 Watsky
3,231,454 A 1/1966 Williams
3,266,064 A 8/1966 Figman
3,297,023 A 1/1967 Foley
3,317,934 A 5/1967 Hinrichs
3,340,551 A 9/1967 Hopkins
3,363,941 A 1/1968 Wierwille
3,390,674 A 7/1968 Jones
3,394,415 A 7/1968 Parker

(Continued)

Primary Examiner — William Thomson

Assistant Examiner — Jeffrey Lipitz

(74) *Attorney, Agent, or Firm* — Lee & Hayes, PLLC

(57) **ABSTRACT**

A device and method for preventing and treating bedsores on a lying patient. The device uses both a fan and a UV light source. The fan dries the skin while the UV light source aids in drying the patient as well as killing harmful pathogens. The device is adjustable so the air and UV light can be directed at various angles and from different heights, to a patient in different positions, prone, supine, and laying on side.

9 Claims, 4 Drawing Sheets

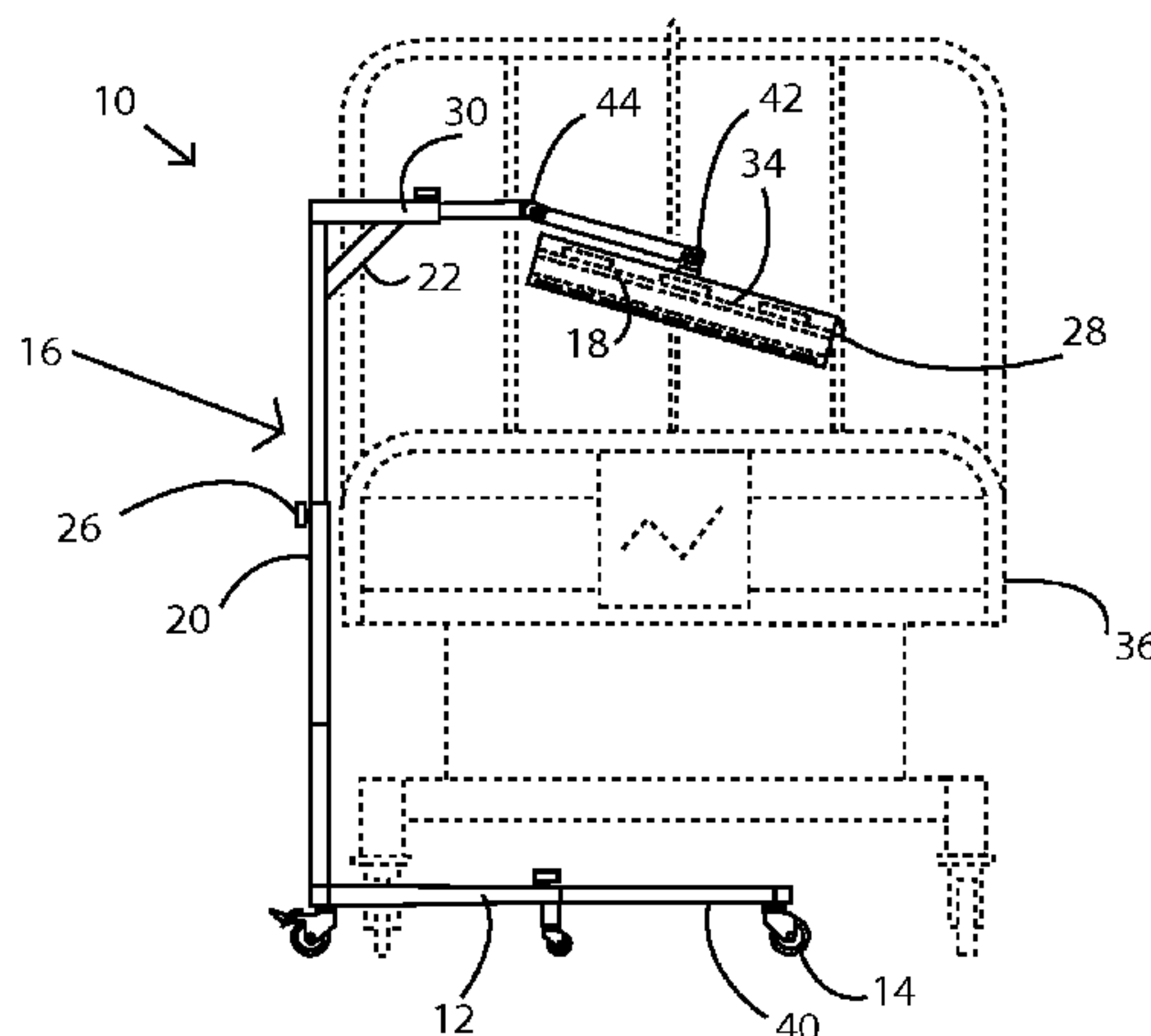

(56)

References Cited

U.S. PATENT DOCUMENTS

3,399,407 A	9/1968	Olsen	4,638,519 A	1/1987	Hess
3,446,203 A	5/1969	Murray	4,642,825 A	2/1987	Kurita
3,459,179 A	8/1969	Olesen	4,653,130 A	3/1987	Senoue et al.
3,462,775 A	8/1969	Markwitz	4,654,903 A	4/1987	Chubb et al.
3,462,778 A	8/1969	Whitney	4,685,222 A	8/1987	Houck
3,467,081 A	9/1969	Glass	4,686,722 A	8/1987	Swart
3,477,071 A	11/1969	Emerson	4,694,520 A	9/1987	Paul et al.
3,485,240 A	12/1969	Fountain	4,745,647 A	5/1988	Goodwin
3,486,177 A	12/1969	Marshack	4,750,224 A	6/1988	Stracke
3,526,908 A	9/1970	Davis	4,750,482 A	6/1988	Sieverding
3,587,568 A	6/1971	Thomas	4,756,094 A	7/1988	Houck
3,605,138 A	9/1971	Tucker	4,768,249 A	9/1988	Goodwin
3,605,145 A	9/1971	Graebe	4,777,679 A	10/1988	DeLooper
3,621,199 A	11/1971	Goldstein	4,780,595 A	10/1988	Alban
3,644,950 A	2/1972	Lindsay, Jr.	4,799,276 A	1/1989	Kadish
3,653,083 A	4/1972	Lapidus	4,825,486 A	5/1989	Kimura et al.
3,656,190 A	4/1972	Regan et al.	4,857,705 A	8/1989	Blevins
3,674,019 A	7/1972	Grant	4,864,671 A	9/1989	Evans
3,678,520 A	7/1972	Evans	4,871,900 A	10/1989	Hickman
3,681,797 A	8/1972	Messner	4,871,900 A	10/1989	Hickman
3,701,173 A	10/1972	Whitney	4,897,890 A	2/1990	Walker
3,705,429 A	12/1972	Nail	4,935,968 A	6/1990	Hunt et al.
3,711,958 A	1/1973	Lepage	4,941,220 A	7/1990	DiMatteo et al.
3,740,777 A	6/1973	Dee	4,944,060 A	7/1990	Peery et al.
3,757,356 A	9/1973	Freeman	4,947,500 A	8/1990	Seiler
3,757,366 A	9/1973	Sacher	4,949,412 A	8/1990	Goode
3,762,404 A	10/1973	Sakita	4,949,413 A	8/1990	Goodwin
3,775,781 A	12/1973	Bruno et al.	4,953,247 A	9/1990	Hasty
3,822,425 A	7/1974	Scales	4,959,059 A	9/1990	Eilender et al.
3,829,914 A	8/1974	Treat	4,961,272 A	10/1990	Lee
3,866,612 A	2/1975	Buker	4,962,552 A	10/1990	Hasty
3,878,621 A	4/1975	Duerre	4,962,769 A	10/1990	Garcia
3,879,776 A	4/1975	Solen	4,989,283 A	2/1991	Krouskop
3,885,257 A	5/1975	Rogers	4,989,343 A	2/1991	Ericsson
3,885,259 A	5/1975	Cheong	4,999,861 A	3/1991	Huang
3,909,858 A	10/1975	Ducker	5,003,654 A	4/1991	Vrzalik
3,919,730 A	11/1975	Regan	5,003,705 A	4/1991	Lee
3,920,006 A	11/1975	Lapidus	5,005,240 A	4/1991	Vrzalik
3,928,876 A	12/1975	Starr	5,007,182 A	4/1991	Fishman
3,974,532 A	8/1976	Ecchuya	5,010,608 A	4/1991	Barnett et al.
4,005,236 A	1/1977	Graebe	5,031,261 A	7/1991	Fenner, Sr.
4,057,861 A	11/1977	Howorth	5,044,029 A	9/1991	Vrzalik
4,068,334 A	1/1978	Randall	5,062,169 A	11/1991	Kennedy et al.
4,099,276 A	7/1978	Hunt et al.	5,103,518 A	4/1992	Gilroy et al.
4,109,331 A	8/1978	Champeau	5,103,519 A	4/1992	Hasty
4,149,285 A	4/1979	Stanton	5,103,577 A	4/1992	Michael
4,193,149 A	3/1980	Welch	5,109,560 A	5/1992	Uetake
4,197,837 A	4/1980	Tringali et al.	5,121,512 A	6/1992	Kaufmann
4,206,524 A	6/1980	Cook	5,161,267 A	11/1992	Smith
4,225,989 A	10/1980	Corbett et al.	5,168,589 A	12/1992	Stroh et al.
4,267,611 A	5/1981	Agulnick	5,233,712 A	8/1993	Jurus et al.
4,280,487 A	7/1981	Jackson	5,243,723 A	9/1993	Cotner et al.
4,305,168 A	12/1981	Holter et al.	5,251,349 A	10/1993	Thomas et al.
4,347,633 A	9/1982	Gammons et al.	5,255,404 A	10/1993	Dinsmoor, III et al.
4,391,009 A	7/1983	Schild et al.	5,267,364 A	12/1993	Volk
4,422,194 A	12/1983	Viesturs et al.	5,267,365 A	12/1993	Walter
4,425,676 A	1/1984	Crane	5,269,071 A	12/1993	Hamabe
4,454,615 A	6/1984	Whitney	5,325,551 A	7/1994	Tappel et al.
4,472,847 A	9/1984	Gammons et al.	5,353,012 A	10/1994	Barham
4,481,686 A	11/1984	Lacoste	5,369,828 A	12/1994	Graebe
4,483,030 A	11/1984	Flick et al.	5,373,595 A	12/1994	Johnson et al.
4,485,505 A	12/1984	Paul	5,375,273 A	12/1994	Bodine
4,488,322 A	12/1984	Hunt et al.	5,377,424 A	1/1995	Albanes
4,494,260 A	1/1985	Olds et al.	5,462,519 A	10/1995	Carver
4,525,885 A	7/1985	Hunt et al.	5,487,196 A	1/1996	Wilkinson et al.
4,525,886 A	7/1985	Savenije	5,526,543 A	6/1996	DiMatteo
4,534,078 A	8/1985	Viesturs et al.	5,542,136 A	8/1996	Tappel
4,542,547 A	9/1985	Sato	5,586,346 A	12/1996	Stacy et al.
4,554,930 A	11/1985	Kress	5,611,772 A	3/1997	Fujimoto
4,572,174 A	2/1986	Eilender et al.	5,651,189 A	7/1997	Coykendall
4,583,255 A	4/1986	Mogaki et al.	5,652,987 A	8/1997	Fujita
4,594,797 A	6/1986	Houck	5,654,694 A	8/1997	Newham
4,614,000 A	9/1986	Mayer	5,787,523 A	8/1998	Lindberg
4,617,690 A	10/1986	Grebe	5,873,137 A	2/1999	Yavets-Chen
4,625,487 A	12/1986	Blakeway	5,873,179 A	2/1999	Gregory
			5,926,884 A	7/1999	Biggie et al.
			5,983,429 A	11/1999	Stacy et al.
			6,105,273 A	8/2000	Johanson et al.
			6,148,461 A	11/2000	Cook et al.
			6,264,888 B1	7/2001	Palestro et al.

(56)

References Cited

U.S. PATENT DOCUMENTS

6,287,253 B1 9/2001 Ortega et al.
6,292,102 B1 9/2001 Smith
6,487,739 B1 12/2002 Harker
6,646,556 B1 11/2003 Smith et al.
6,687,937 B2 2/2004 Harker
6,799,342 B1 10/2004 Jarmon
6,949,223 B2 9/2005 McEllen
7,030,764 B2 4/2006 Smith et al.
7,090,647 B2 8/2006 Mimura et al.
7,225,488 B2 6/2007 Wu

7,761,945 B2 7/2010 Butler
8,011,041 B2 9/2011 Hann
8,087,980 B2 1/2012 Palmer
8,973,186 B2 3/2015 Bhai
9,015,885 B2 4/2015 Chapin
2001/0023363 A1* 9/2001 Harth et al. 607/90
2004/0098069 A1 5/2004 Clement et al.
2004/0181268 A1* 9/2004 Anderer 607/90
2005/0273940 A1 12/2005 Petrosenko et al.
2006/0025686 A1 2/2006 Ueno et al.
2006/0065060 A1 3/2006 Ito et al.
2014/0173825 A1 6/2014 Chiang et al.

* cited by examiner

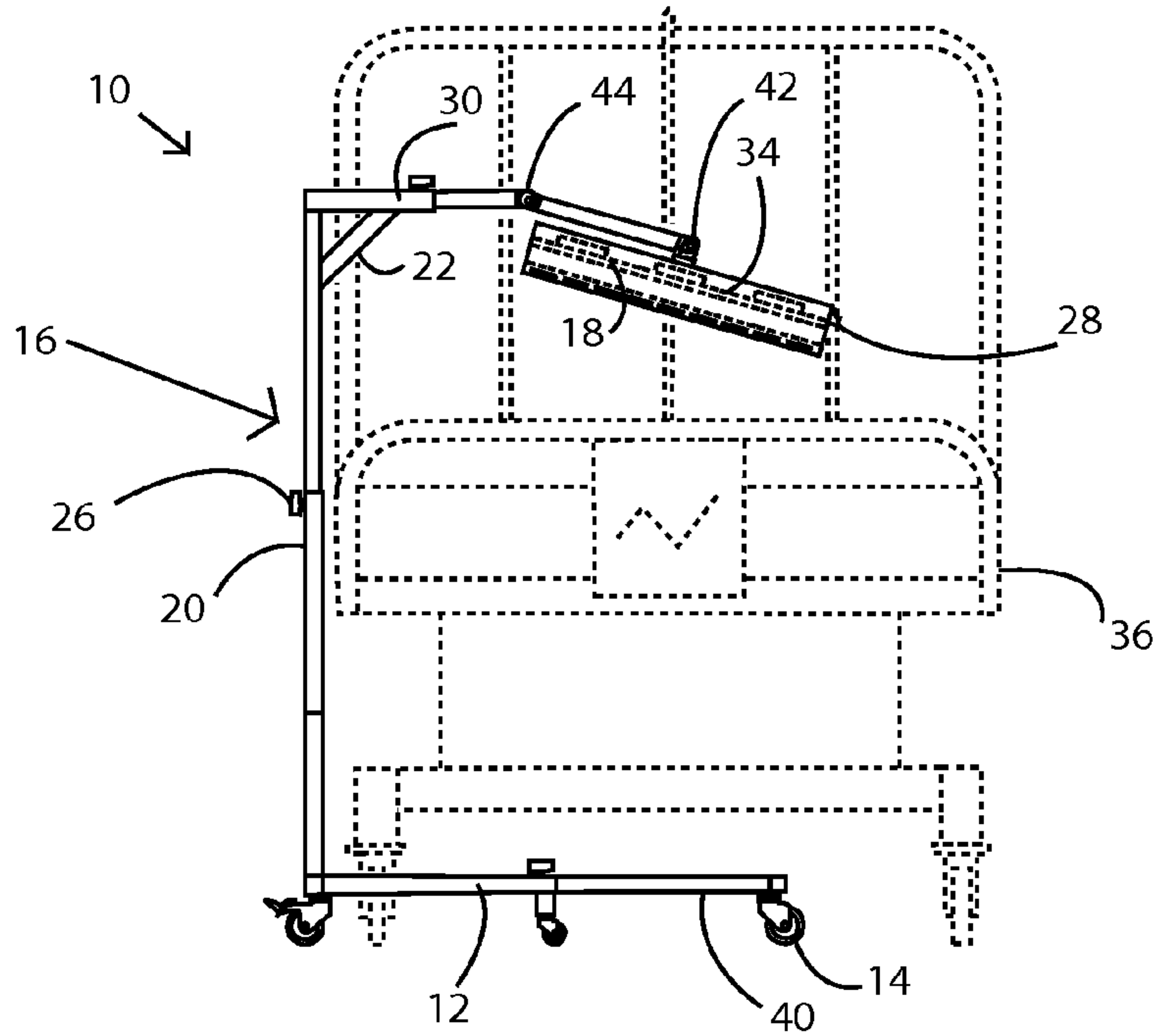

Fig. 1

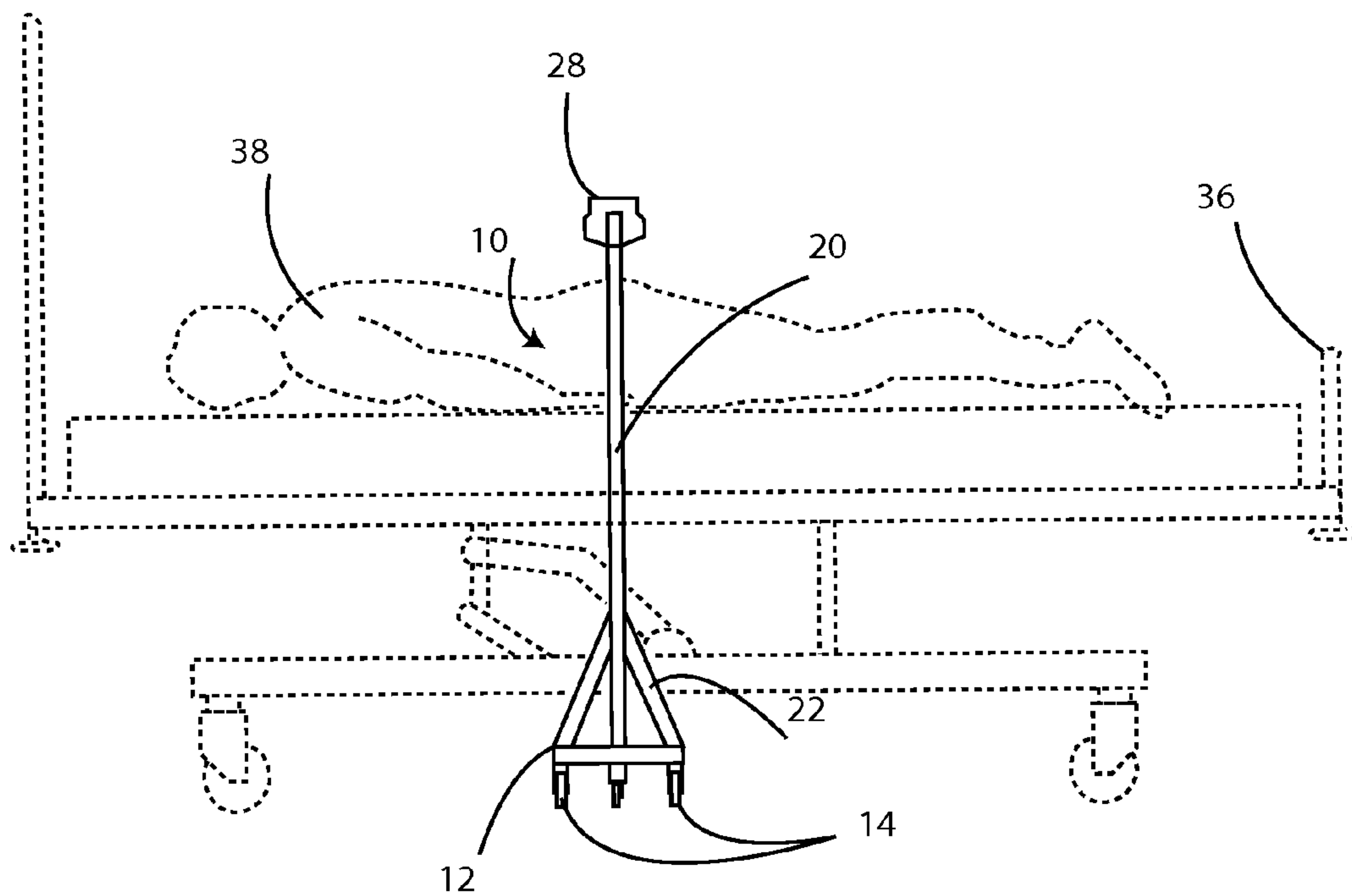

Fig. 2

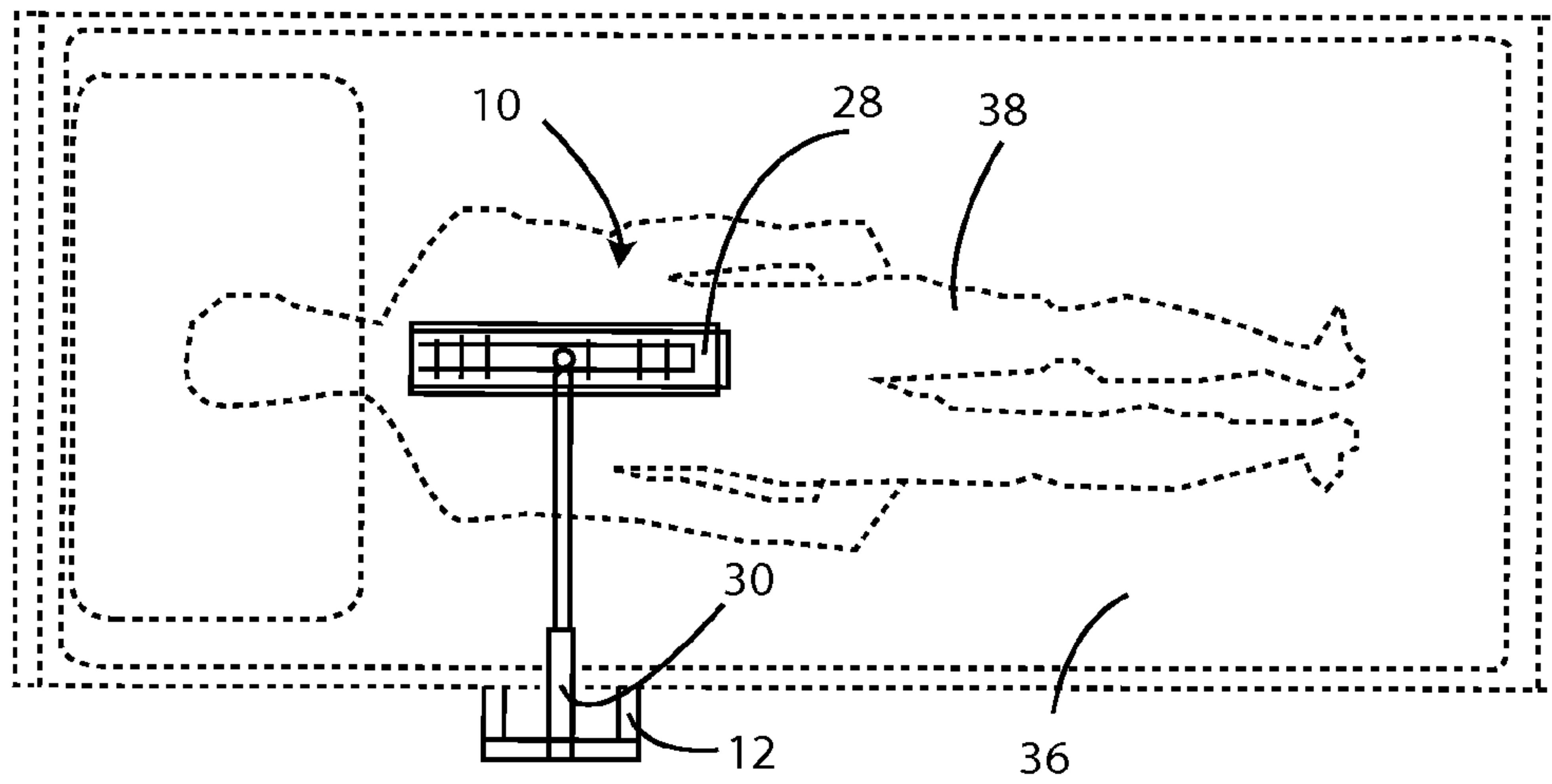

Fig. 3

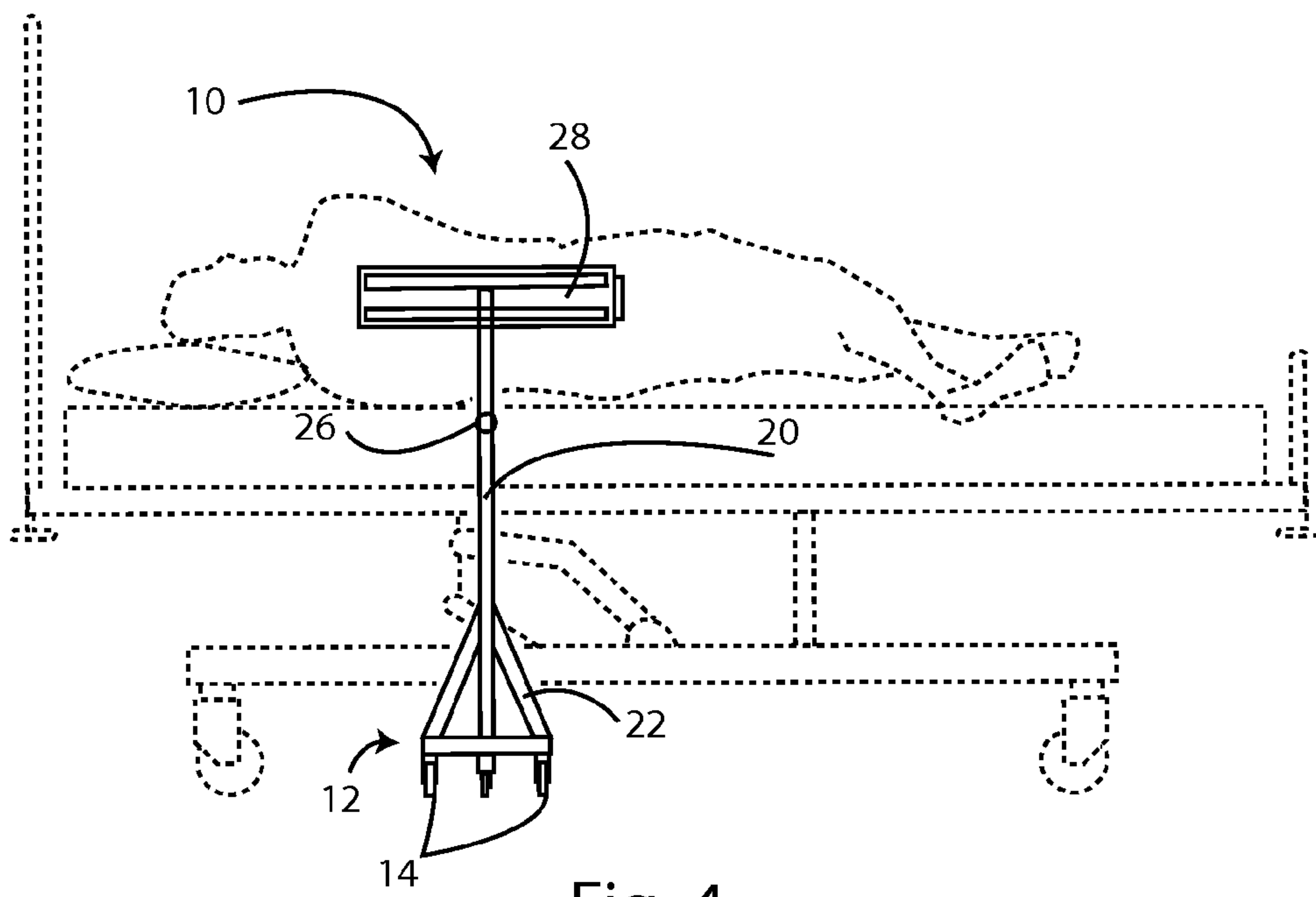

Fig. 4

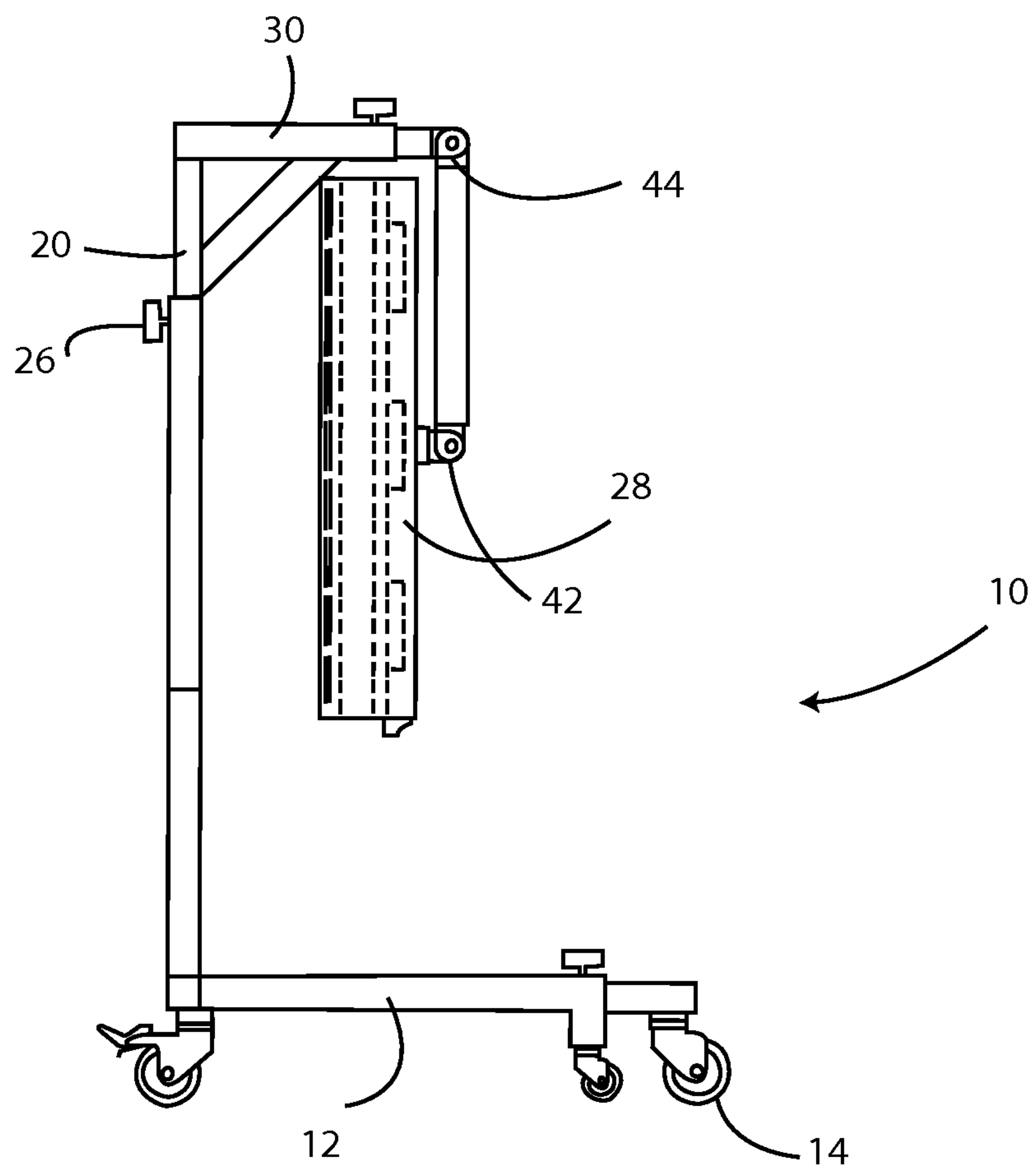

Fig. 5

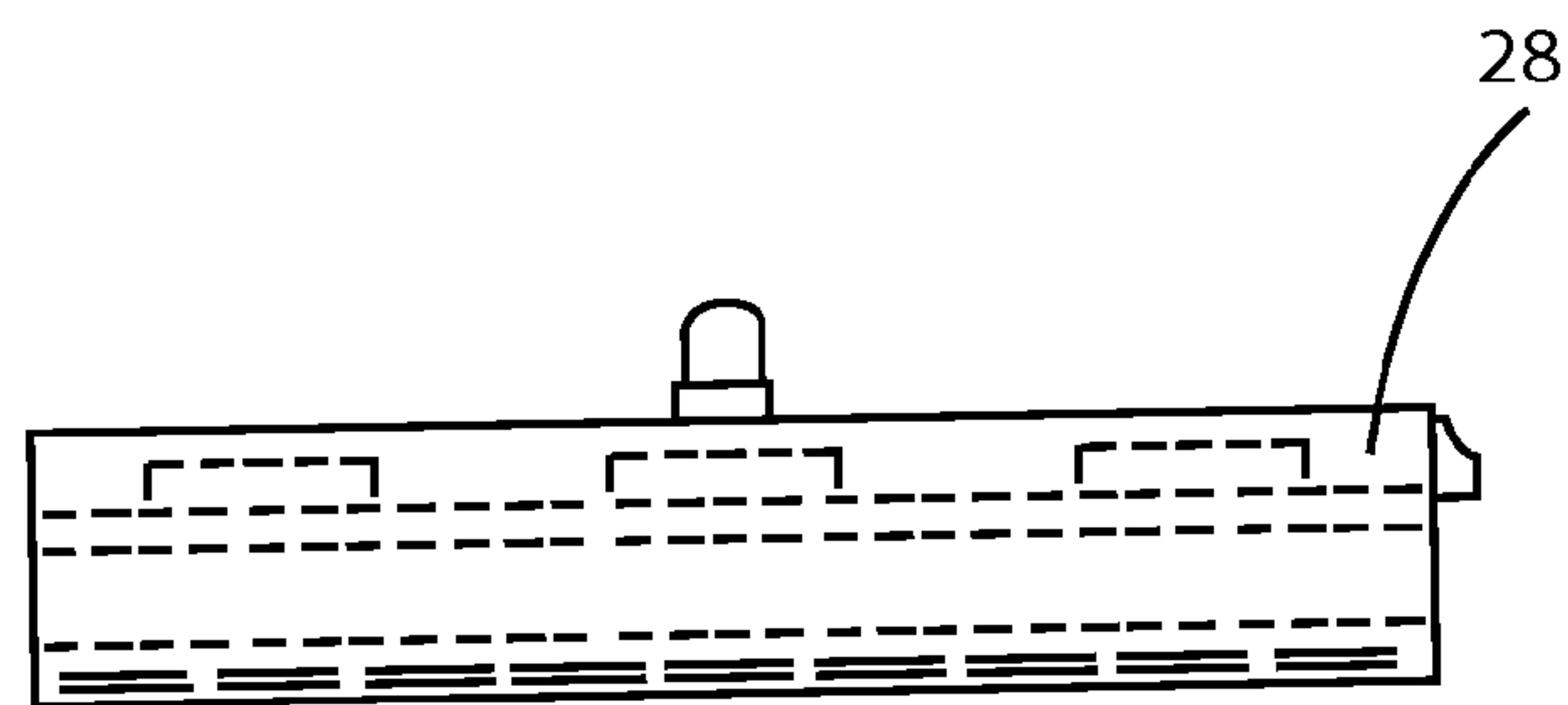

Fig. 6

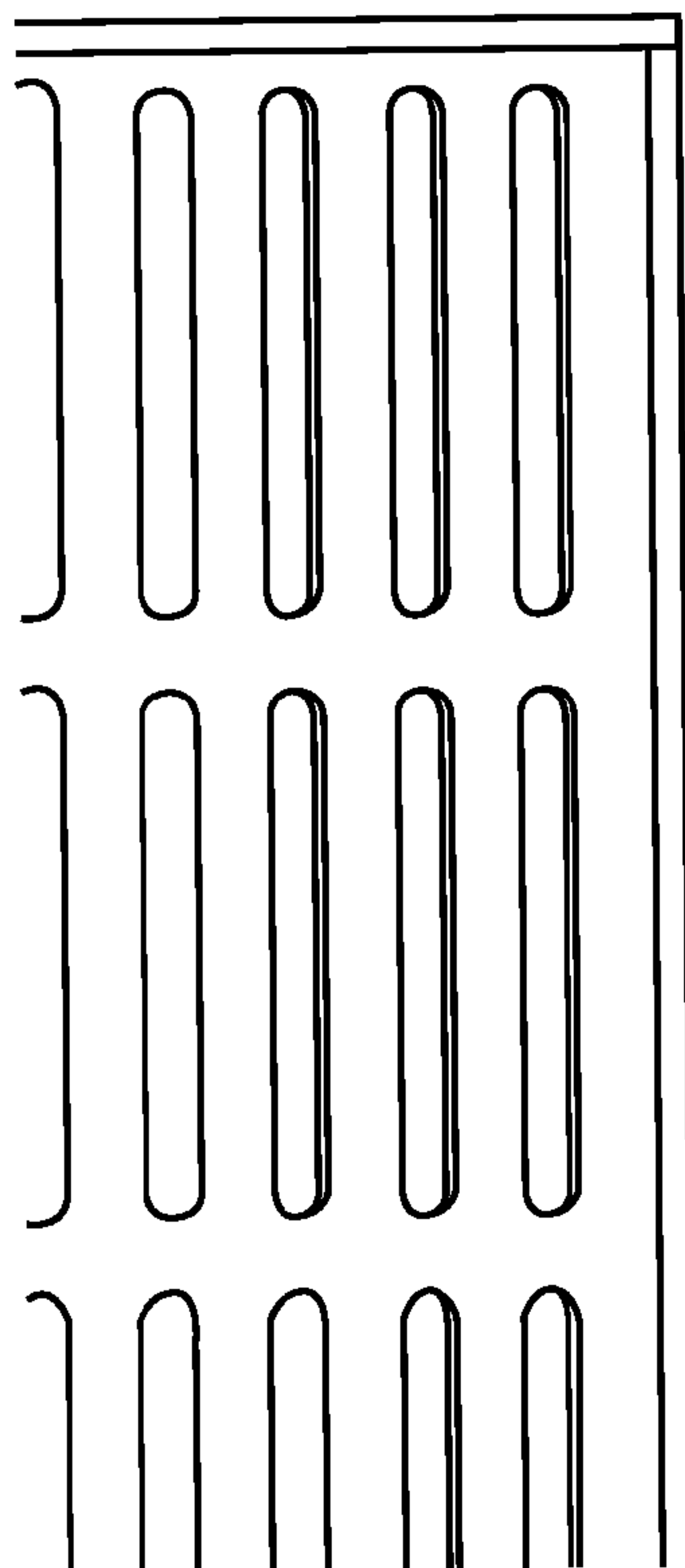

Fig. 7

1

**BED DRYING DEVICE, UV LIGHTS FOR
BEDSORES**

TECHNICAL FIELD

The presently disclosed and claimed disclosed technology generally relates to a method and apparatus for drying a person in a lying position, and more particularly to a device for maintaining adequate skin dryness and skin treatment during extended hospital stays.

BACKGROUND

People who are confined to a bed for extended periods of time can develop moisture build up on their skin where the skin does not have sufficient exposure to dry. Similar to being in a pool for extended periods, the skin in these locations can become soft. Additionally, the moisture build up can become a bacterial breeding ground. The skin in these areas is frequently under constant pressure from the patient's body weight.

These areas of skin can begin to stick to the bed and tear away from the person. The tearing can result in open sores which are painful and can bleed significantly. Once the open sores are present, there is a significant risk of infection. These sores require additional care and expense that would not be necessary if the bed sores had been prevented beforehand. Treatment and prevention of bed sores can require specialized beds or having the patient leave the bed for extended periods of time. If a specialized bed is used the treatment can be expensive but can be the only choice if the patient is unable to leave the bed.

Hospital patients are sometimes confined to long periods of bed rest due to causes including surgical recovery and coma. The patient's condition, either conscious or not, often requires the patient to lie in substantially one position for extended periods of time. These extended sedentary periods place hospital patients at an increased risk of bed sores, related infection, and medical care that otherwise would not be necessary.

SUMMARY OF THE DISCLOSURE

The purpose of the Abstract is to enable the public, and especially the scientists, engineers, and practitioners in the art who are not familiar with patent or legal terms or phraseology, to determine quickly from a cursory inspection, the nature and essence of the technical disclosure of the application. The Abstract is neither intended to define the inventive concept(s) of the application, which is measured by the claims, nor is it intended to be limiting as to the scope of the inventive concept(s) in any way.

Still other features and advantages of the presently disclosed and claimed disclosed technology will become readily apparent to those skilled in this art from the following detailed description describing preferred embodiments of the inventive concept(s), simply by way of illustration of the best mode contemplated by carrying out the disclosed technology. As will be realized, the inventive concept(s) is capable of modification in various obvious respects all without departing from the disclosed technology. Accordingly, the drawings and description of the preferred embodiments are to be regarded as illustrative in nature, and not as restrictive in nature.

The present disclosed technology consist of a method and apparatus for treating and preventing bed sores and the associated issues, including insufficient drying and bacterial

2

breeding in a bed-ridden hospital patient. The present disclosed technology dry the patient as well as destroy the harmful bacteria present on a person's skin.

The apparatus utilizes a forced air source, such as a fan, and a UV light source. Often the patients are unable to make significant movements. The apparatus allows the patient to make a minimal movement to expose the patient's skin. The fan and UV light are able to rotate around a bed to a position where the bed patient can roll onto his side or stomach to expose the skin at risk of bed sores and infection, typically the patient's back, to the forced air and UV light. Once the skin is exposed, the apparatus can be set up so that the forced air source and UV light source can be positioned above the patient or to the side of the patient as necessary.

This method of drying a patient and killing harmful bacteria is accomplished by utilizing a drying mechanism, such as a fan, in addition to a UV lamp. The method consists of a first step of positioning the patient on his side or stomach in order to expose the area of skin to be treated. The second step of the method is positioning a device such that the UV lamp and fan extend over, or around, the patient bed. The third step of the method is rotating the lamp and fan assembly to be directed at the area of skin to be treated. The fourth step is activating the lamp and UV light assembly for sufficient time to effectively treat the area.

BRIEF DESCRIPTION OF THE DRAWINGS

FIG. 1 is a side view of one embodiment of the disclosed technology positioned to operate over a bed.

FIG. 2 is a rear view of one embodiment of the disclosed technology in operation.

FIG. 3 is a top view of one embodiment of the disclosed technology, positioned over a patient's back with treatment head rotated parallel to patients body.

FIG. 4 is a rear view of one embodiment of the disclosed technology, positioned to dry the patient's back when on his/her side with treatment head parallel to patient's body.

FIG. 5 is a side view of one embodiment of the disclosed technology, with the treatment head folded down for transportation or storage.

FIG. 6 is a side view of one embodiment of the disclosed technology, treatment head displaying positions of fan and UV light.

FIG. 7 is a bottom view of one embodiment of the disclosed technology, treatment head displaying ventilation.

DETAILED DESCRIPTION OF THE
EXEMPLARY EMBODIMENTS

While the presently disclosed technology are susceptible of various modifications and alternative constructions, certain illustrated embodiments thereof have been shown in the drawings and will be described below in detail. It should be understood, however, that there is no intention to limit the inventive concept(s) to the specific form disclosed, but, on the contrary, the presently disclosed and claimed disclosed technology are to cover all modifications, alternative constructions, and equivalents falling within the spirit and scope of the inventive concept(s) as defined in the claims.

The disclosed device is a skin treatment tool with a therapeutic light and fan, which is made to treat a patient in a bed. The device is made to be placed over a bed, with the patient lying face down or on a side. The light and fan dry the skin and treat the skin with beneficial wavelengths of light. FIG. 1 represents a preferred embodiment of the presently disclosed and claimed technology. FIG. 1 illustrates a patient drying

3

device 10 having a frame 16, the frame having a base 12, wheels 14, vertical support 20, horizontal support 30, and forced air fan 18 and UV light source 34 located in a treatment head 28. In a preferred embodiment the patient drying device 10 utilizes four wheels 14, attached near the four corners of the underside of base 12. A fifth wheel may be placed in a support location on the base 12. It is to be noted that horizontal support arm 30 can extend over a bed horizontally, or may be placed at the side of a patient as in FIG. 4, and the treatment head 28 may be rotated at the end of the horizontal support arm 30. The wheels 14 can be of any type mountable to a base, with castor wheels being preferred. The wheels 14 can be constructed with any material that allows for free rotation, including metal, plastic, or a combination of materials. Shown in FIG. 1 is a bed 36, and shown in FIG. 2 is a patient 38 in the bed 36.

Base 12 can have extending pieces 40, on which wheels 14 are placed. The base 12 may have rounded corners for improved safety and portability. The base 12 is preferably metal, such as stainless steel, but other materials can be used to provide sufficient strength and stability for the treatment head 28. Similarly, the size of the base 12 must be sufficiently extendable to support the patient drying device 10 with the treatment head 28 extended in any allowable direction. In a typical configuration of the device 10, the base is approximately 23.5 inches long and 12 inches wide. The vertical support 20 would typically extend to about 59 inches high, and the treatment head 28 is about 5.5 inches wide and 24 inches long. In one embodiment, the extending portions 40 of the base 12 extend to 37.5 inches.

Attached to the top of base 12 is vertical support 20. Vertical support 20 extends from base 12 in a substantially vertical direction. Vertical support 20 may have telescopic capabilities to adjust the height of the treatment head 28 to accommodate larger patients and higher beds. Incorporating telescopic capabilities into vertical support 20 also allows for easier storage and transport of patient drying device 10 as well as personalized treatment for different sized patients.

Attached to the top of vertical support 20 is horizontal support arm 30. Braces 22 may be attached to the vertical support 20 for additional support of the horizontal support arm 30. The treatment head 28 can be attached to horizontal support arm 30 by a movable joint 42, to allow the treatment head 28 to be positioned as shown in the figures. Another flexible joint 44 can allow the treatment head to be placed in a vertical position for storage or treatment, as shown in FIGS. 5. For improved functionality, horizontal support arm 30 can also have telescopic capabilities. In this manner it would be possible to treat both sides of a patient without moving the patient drying device 10 to the opposite side of the patient bed.

Attached to, or near, the end of the horizontal support arm 30 opposite of vertical support 20 is treatment head 28, which contains a forced air fan 18 and UV light source 34. The treatment head 28 can be mounted to rotate along the axis of horizontal support arm 30 to allow a user freedom to direct the forced air and UV light source in various ways. FIG. 1 also shows horizontal support 30 incorporating a joint 44 within the length of horizontal support 30. While different types of joints can be used, a ball joint is preferred for increased selection in the positioning of forced air fan 18 and UV light source 34, incorporation of joint 42 allows the treatment head 28 to be positioned either above a patient or to the side of the patient. For example, it is desirable to have forced air fan 18 and UV light source 34 directed away from vertical support 20 when treating the near side of a patient. It is also desirable to position forced air fan 18 and UV light source 34 toward

4

vertical support 20 in order to treat the far side of a patient without having to move the entire patient drying device 10.

FIG. 2 represents a rear view of the presently disclosed technology, which also shows a side view of the patient. FIG. 2 shows the addition of braces 22. While not always necessary, braces 22 are added to reduce stress on the vertical support 20 and increase rigidity of the apparatus.

FIG. 3 shows a top view of the presently disclosed technology. FIG. 3 illustrates one embodiment where base 12 is substantially longer than it is wide with horizontal support arm 30 extending in a substantially similar direction. In FIG. 3, the patient is lying on his/her stomach, with the treatment head 28 over an area of the torso to be dried or treated with UV.

FIG. 4 represents a side view of the presently disclosed and claimed inventive concepts. FIG. 4 illustrates one embodiment with a patient lying on his or her side on a bed. FIG. 4 shows the vertical support 20 with telescopic abilities. Vertical support 20 can be locked in place with height adjustment knob 26. Other locking mechanisms can be used also, including flip locks or hole and pin systems.

FIG. 4 also shows treatment head 28 in a horizontal position next to the back of a patient laying on his/her side. A suitable UV light source in the treatment head 28 is a (brand) Phillips (model) Narrowband TL which uses a 20 watt UV heat lamp. A suitable force air fan in the treatment head 28 is a (brand) Dayton (model) Square Axial fan, which has multiple speed settings. The treatment head 28 has a cover with slots through which air and UV light is directed to the patient.

FIG. 5 shows the patient drying device 10 in a compact configuration for storage.

FIG. 6 shows the side view of a treatment head.

FIG. 7 shows a slot in the bottom of a treatment head.

What is claimed is:

1. An apparatus for drying and killing harmful bacteria for bed-ridden patients comprising:

a base member that telescopes from a fully contracted length to a fully extended length, the fully contracted length being less than half of a bed width and the fully extended length being at least the bed width;

a plurality of wheels coupled to the base member;

a mast having a first end coupled to the base member, the mast extending transverse to the base member, and the mast being telescopic to a plurality of lengths;

an arm having a first end coupled to a second end of the mast, the arm extending transverse to the mast and the arm telescoping to a plurality of lengths, the arm including a pivot point, and the pivot point being located between the first end of the arm and a second end of the arm;

a treatment head rotatably coupled to the second end of the arm, the treatment head including an ultraviolet light source and a forced air source; and

wherein the arm is rotatably coupled to the treatment head via a joint, the joint allowing for rotation from a horizontal position to a vertical position.

2. The apparatus of claim 1, wherein the base member is substantially planar.

3. The apparatus of claim 1, wherein the arm telescopes from a fully contracted length to a fully extended length, the fully contracted length being less than half of the bed width and the fully extended length being at least the bed width.

4. The apparatus of claim 1, wherein a conjunction between the treatment head and the second end of the arm comprises a ball joint with a 360 degree rotation radius relative to a plane of the base member.

5

5. The apparatus of claim 1, wherein a conjunction between the treatment head and the second end of the arm comprises a ball joint with a 360 degree rotation radius around the arm.

6. The apparatus of claim 1, wherein the base member and the arm are telescopable to substantially a same length.

7. An apparatus for drying a patient in a bed comprising:
 a base member that telescopes to a plurality of lengths;
 a plurality of wheels coupled to the base member;
 a mast having a first end coupled to the base member, the mast extending transverse to the base member, and the mast being telescopable to a plurality of lengths;

an arm having a first end coupled to a second end of the mast, the arm extending transverse to the mast, the arm telescoping to a plurality of lengths, the arm including a pivot point located between the first end of the arm and a second end of the arm;

a treatment head, a center portion of the treatment head rotatably coupled to the second end of the arm such that a portion of the treatment head extends over the arm and a portion of the treatment head extends past the second end of the arm, the treatment head including an ultraviolet light source and a forced air source; and wherein the arm is rotatably coupled to the treatment head via a joint, the joint allowing for rotation from a horizontal position to a vertical position.

6

8. The apparatus of claim 7, wherein the pivot point comprises a ball joint with a rotation radius allowing a portion of the arm to rotate in any direction.

9. A method, comprising:

drying a person with a device, the device comprising a base member that telescopes from a fully contracted length to a fully extended length, the fully contracted length being less than half of a bed width and the fully extended length being at least the bed width, the device further comprising a plurality of wheels coupled to the base member and a mast having a first end coupled to the base member, the mast extending transverse to the base member, and the mast being telescopable to a plurality of lengths, the device further comprising an arm having a first end coupled to a second end of the mast, the arm extending transverse to the mast and the arm telescoping to a plurality of lengths, the arm including a pivot point, and the pivot point being located between the first end of the arm and a second end of the arm, and a treatment head rotatably coupled to the second end of the arm, the treatment head including an ultraviolet light source and a forced air source, and wherein the arm is rotatably coupled to the treatment head via a joint, the joint allowing for rotation from a horizontal position to a vertical position.

* * * * *