

US009297370B2

(12) **United States Patent**
Brüggemann et al.

(10) **Patent No.:** **US 9,297,370 B2**
(45) **Date of Patent:** **Mar. 29, 2016**

(54) **MEDICAL INJECTION DEVICE WITH ELECTRIC MOTOR DRIVE CONTROL**

(2013.01); *A61M 5/14244* (2013.01); *F04B 49/06* (2013.01); *A61M 5/14566* (2013.01); *A61M 2205/3306* (2013.01); *A61M 2205/3365* (2013.01); *A61M 2205/8212* (2013.01)

(75) Inventors: **Ulrich Brüggemann**, Frankfurt am Main (DE); **Scott Preece**, Coventry (GB); **Christopher Langley**, Warwickshire (GB)

(58) **Field of Classification Search**
USPC 604/131, 151, 152, 154, 155, 890.1, 604/891.1
See application file for complete search history.

(73) Assignee: **Sanofi-Aventis Deutschland GmbH**, Frankfurt am Main (DE)

(56) **References Cited**

(*) Notice: Subject to any disclaimer, the term of this patent is extended or adjusted under 35 U.S.C. 154(b) by 578 days.

U.S. PATENT DOCUMENTS

3,701,345 A 10/1972 Heilman et al.
4,908,017 A 3/1990 Howson et al.

(Continued)

(21) Appl. No.: **13/141,781**

FOREIGN PATENT DOCUMENTS

(22) PCT Filed: **Dec. 23, 2009**

AU 525126 B2 10/1982
EP 0319267 A2 6/1989

(86) PCT No.: **PCT/EP2009/067827**

(Continued)

§ 371 (c)(1),
(2), (4) Date: **Oct. 22, 2011**

OTHER PUBLICATIONS

(87) PCT Pub. No.: **WO2010/076275**
PCT Pub. Date: **Jul. 8, 2010**

Form PCT/IB/326, Notification Concerning Transmittal of International Preliminary Report on Patentability, Jul. 7, 2011.

(Continued)

(65) **Prior Publication Data**
US 2012/0116311 A1 May 10, 2012

Primary Examiner — Nathan R Price
Assistant Examiner — Anh Bui

(30) **Foreign Application Priority Data**

(74) *Attorney, Agent, or Firm* — McDonnell Boehnen Hulbert & Berghoff LLP

Dec. 29, 2008 (EP) 08022476

(57) **ABSTRACT**

(51) **Int. Cl.**
A61M 37/00 (2006.01)
F04B 17/03 (2006.01)
A61M 5/142 (2006.01)
A61M 5/145 (2006.01)
F04B 49/06 (2006.01)

An injection device for delivering a medicament to the human or animal body. The injection device comprising a housing, a piston rod for driving a bung of a medicament container, a drive mechanism including a motor for providing an output drive to the piston rod for delivering the medicament; and controller for controlling operation of the device.

(52) **U.S. Cl.**
CPC *F04B 17/03* (2013.01); *A61M 5/1452*

6 Claims, 6 Drawing Sheets

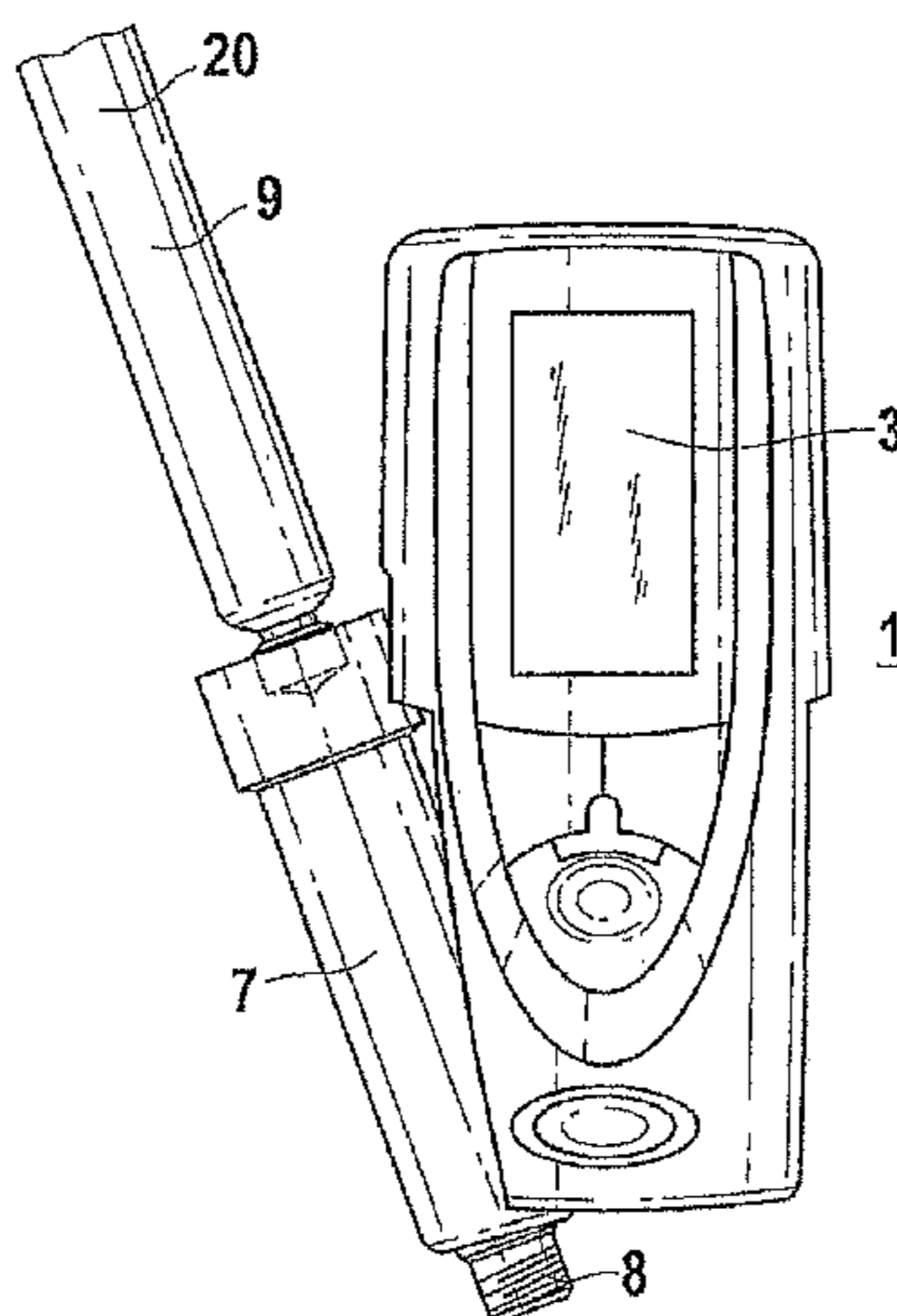

(56)

References Cited

WO 2007079016 A2 7/2007
WO 2007094833 A1 8/2007

U.S. PATENT DOCUMENTS

6,340,357 B1 1/2002 Poulsen et al.
6,362,591 B1 3/2002 Moberg
2007/0088266 A1 4/2007 Yamauchi et al.

FOREIGN PATENT DOCUMENTS

GB 2428745 A 2/2007
JP 200737753 A 2/2007

OTHER PUBLICATIONS

Office Action Issued in European Patent Application No. 09796390.4 dated Jun. 25, 2013.

English Translation of Notice of Reasons for Rejection issued in Japanese Patent Application No. 2011-542823 issued Nov. 26, 2013.

English Translation of Notice of Reasons for Rejection Issued in Japanese Patent Application No. 2011-542823 issued Sep. 2, 2014.

Fig. 1

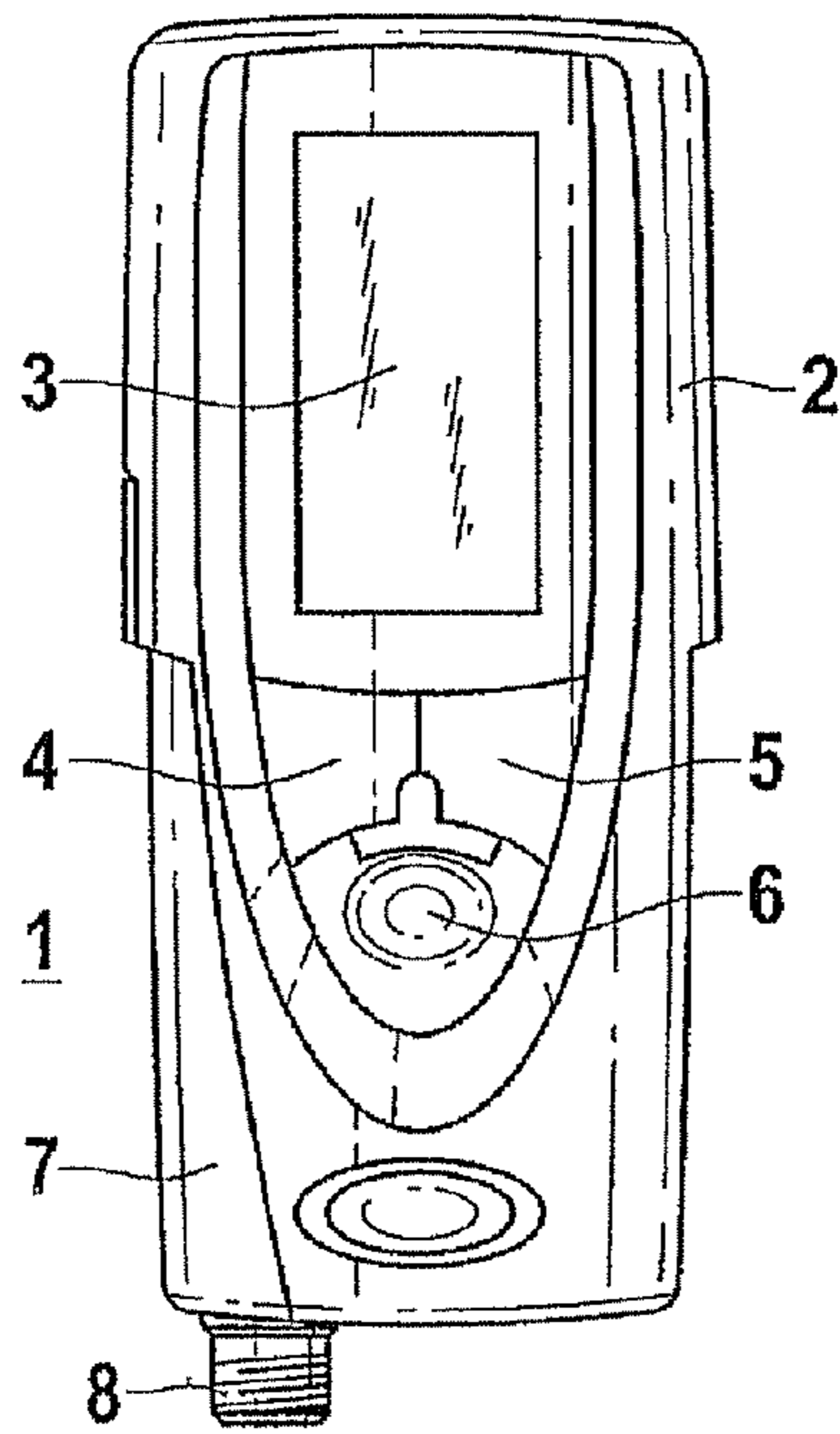
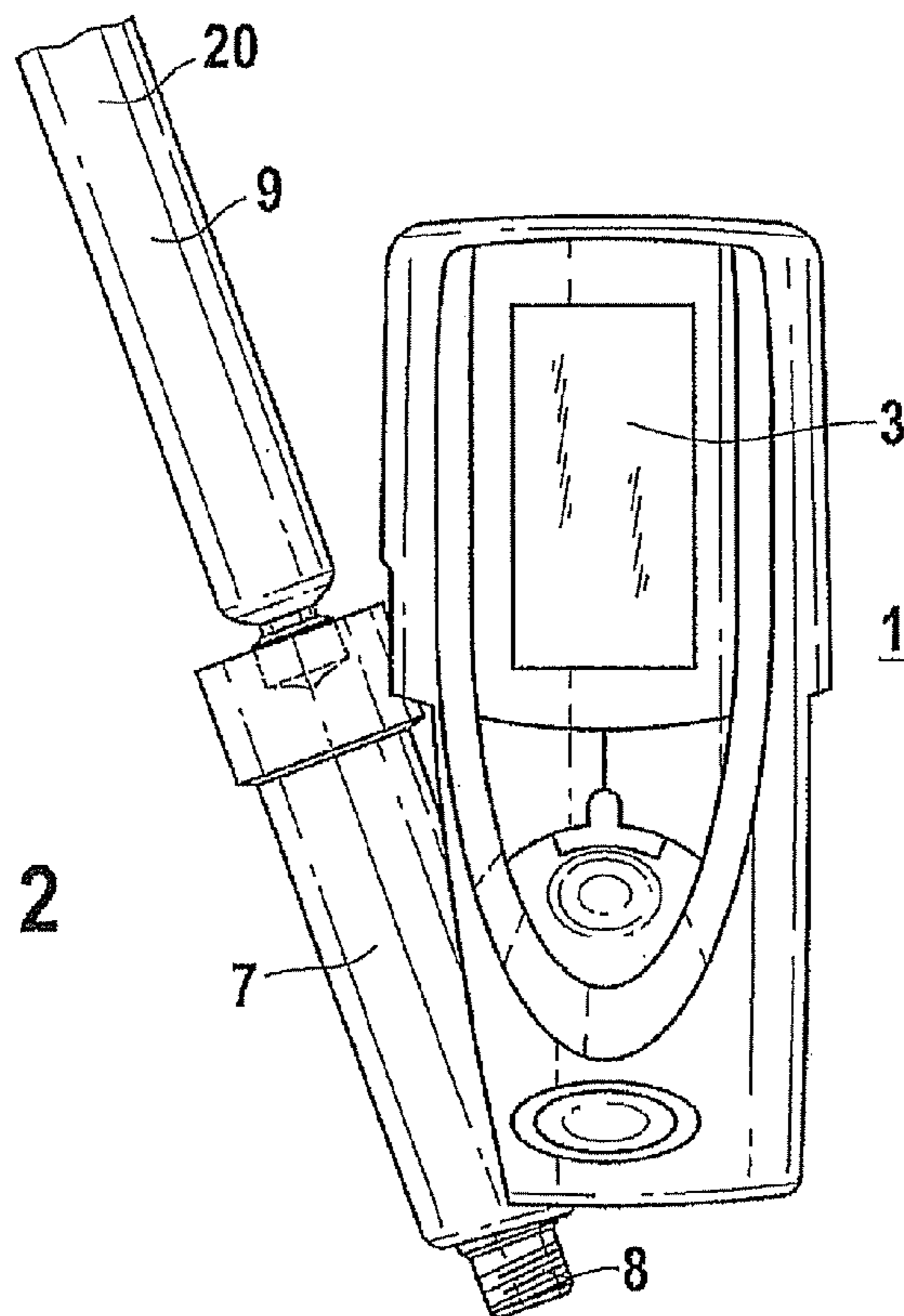
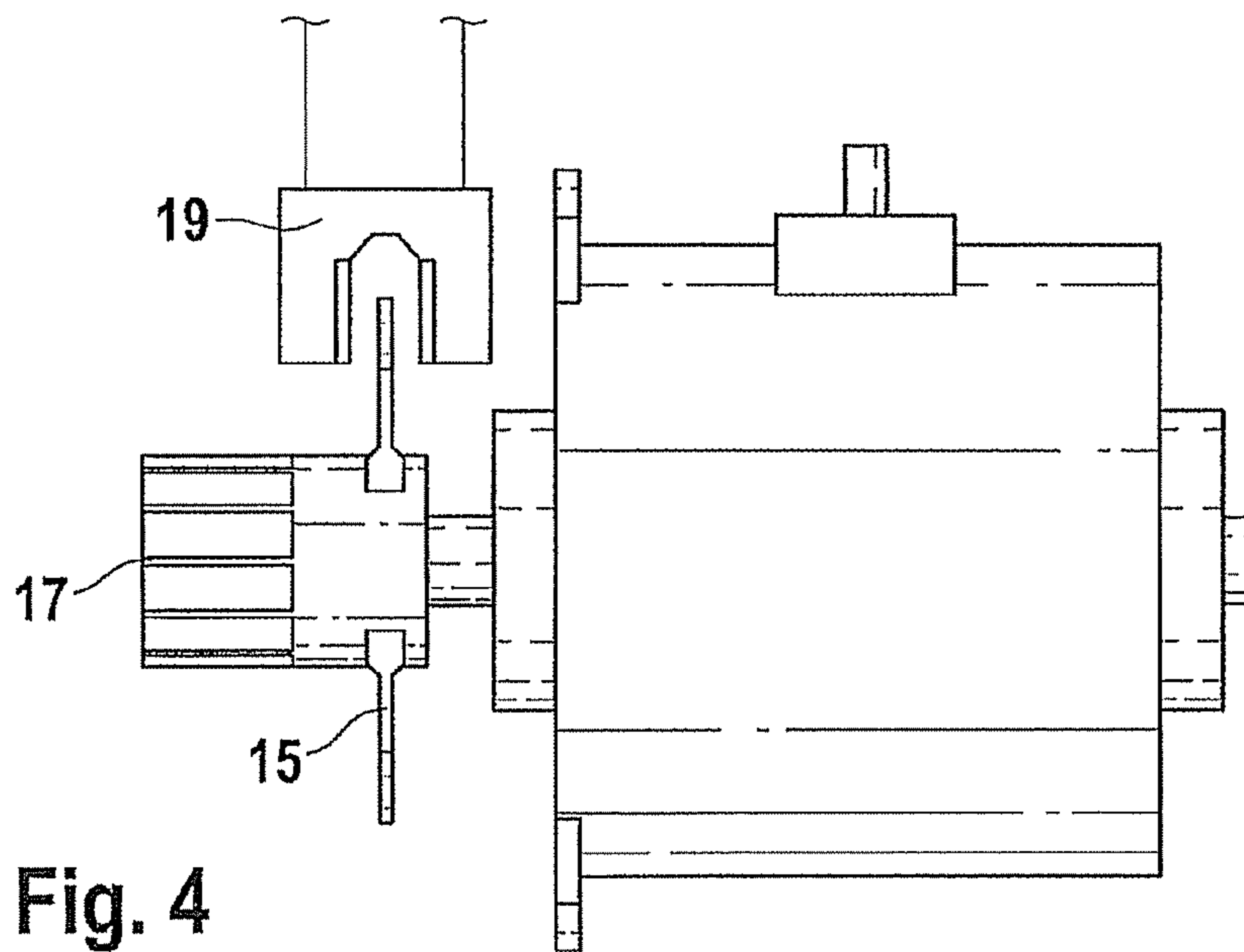
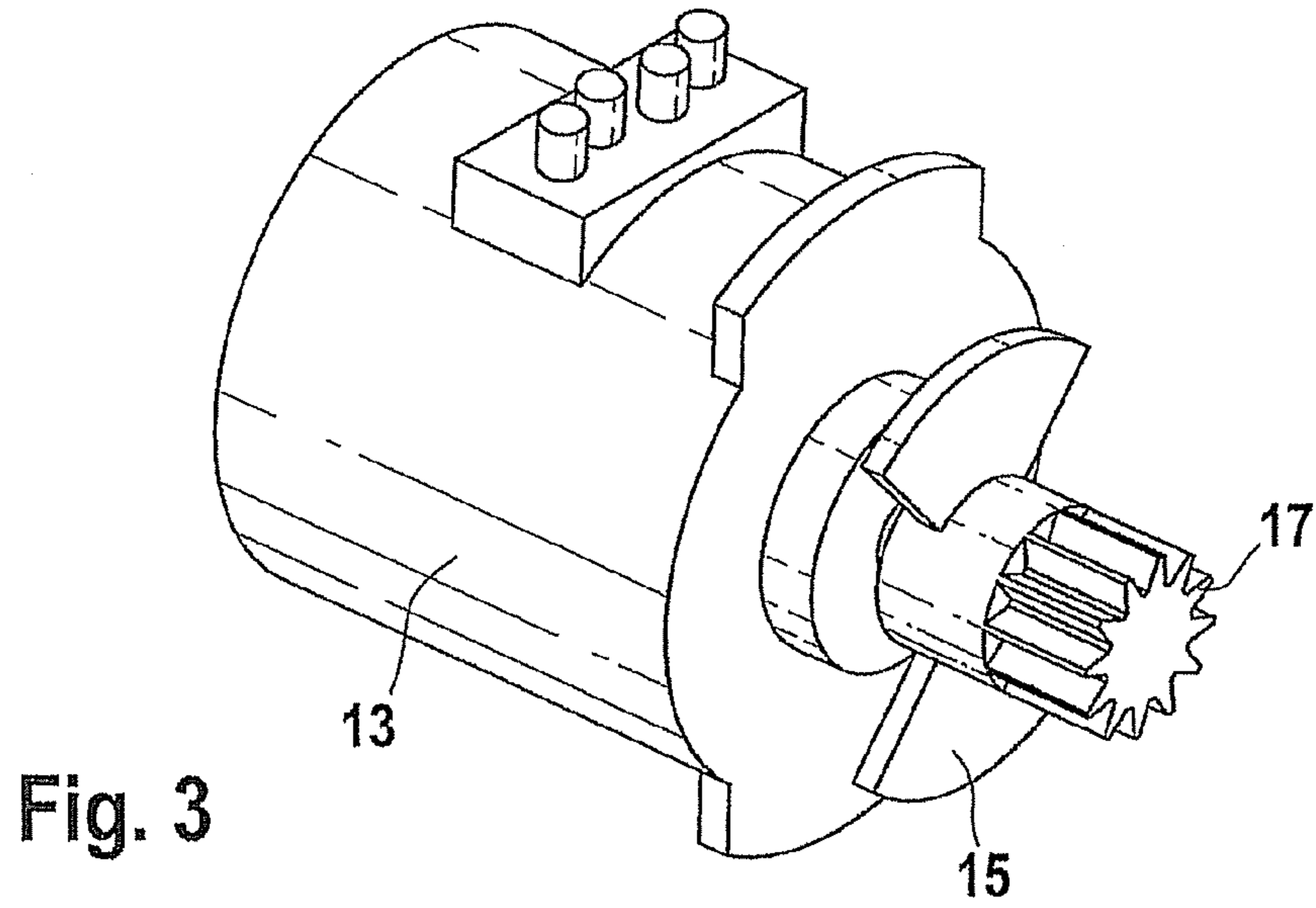

Fig. 2





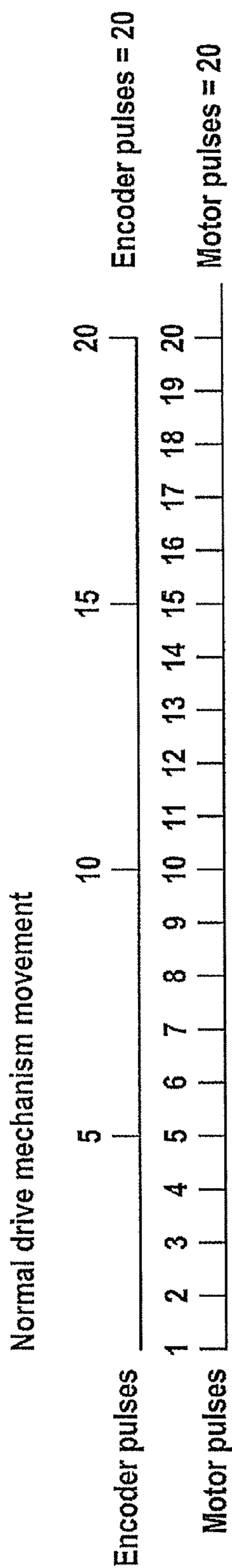

Fig. 5a

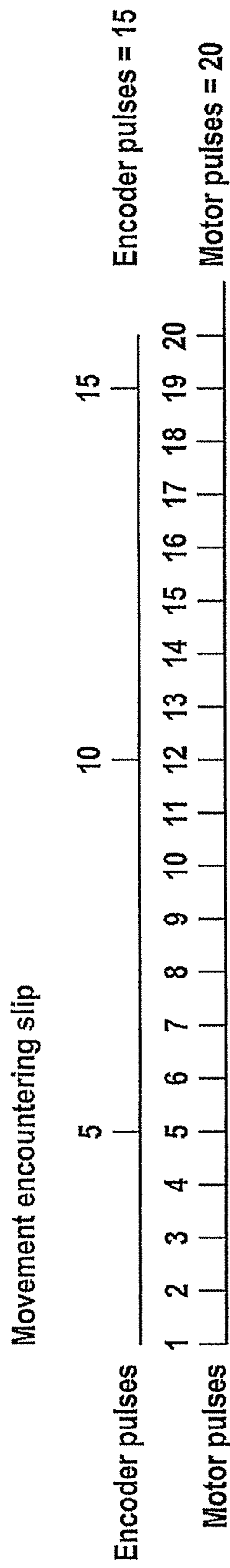

Fig. 5b

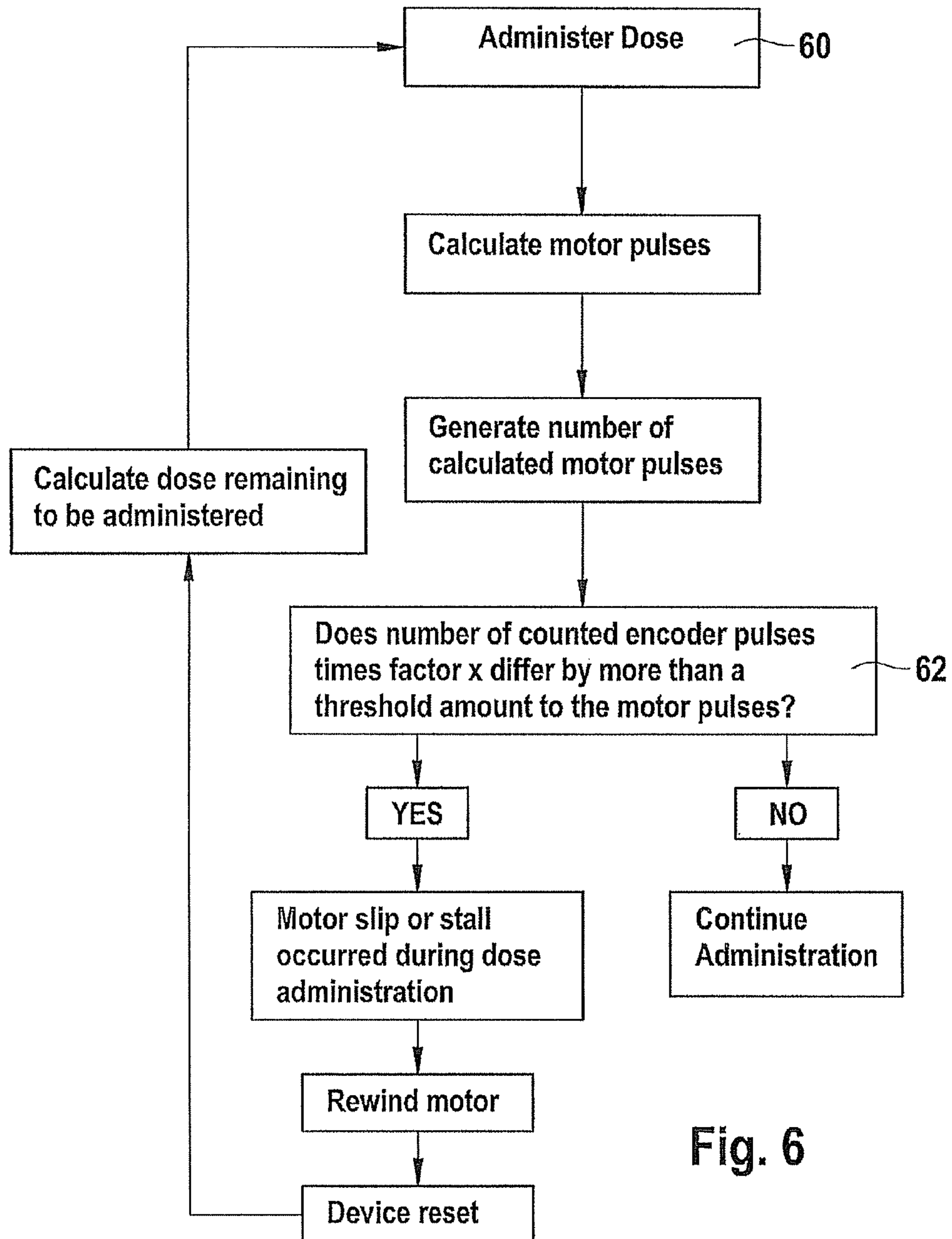

Fig. 6

70

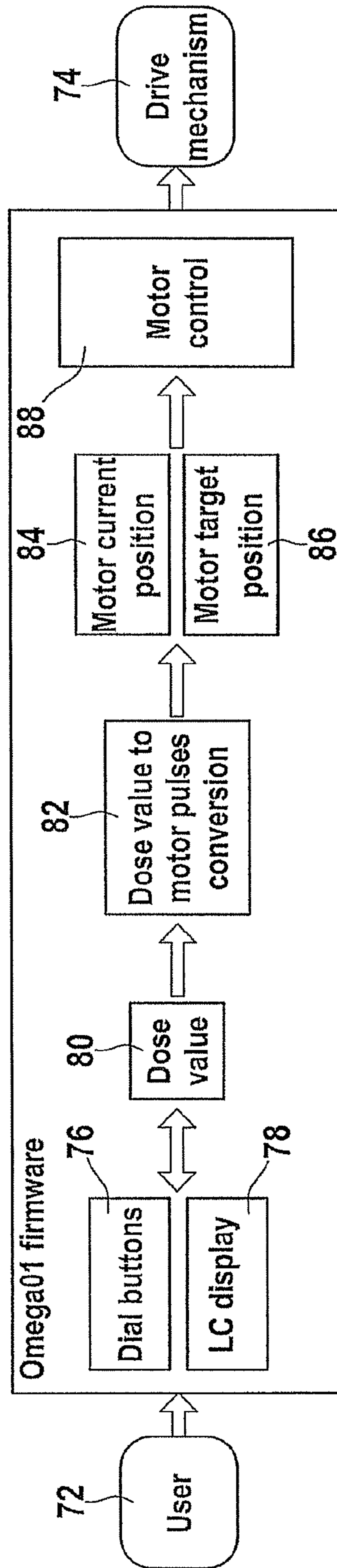

Fig. 7

1**MEDICAL INJECTION DEVICE WITH
ELECTRIC MOTOR DRIVE CONTROL****CROSS REFERENCE TO RELATED
APPLICATIONS**

The present application is a 35 U.S.C. 371 National Application of PCT/EP2009/067827 filed Dec. 23, 2009, which claims priority to European Patent Application No. 08022476.9, filed Dec. 29, 2008, the entire contents of which are incorporated entirely herein by reference.

FIELD OF INVENTION

This invention relates to injection devices for delivering medicine to the human or animal body and in particular, but not exclusively, to devices having a replaceable medicament cartridge, including auto-injectors. Such devices are commonly used by those with diabetes for the administration of insulin.

BACKGROUND

Medicament delivery devices are routinely used by persons without formal medical training, i.e. patients where self-management of their condition is increasingly common. These circumstances set a number of requirements for medicament delivery devices of this kind. The injector should be robust in construction, yet easy to use in terms of its operation by a user and the manipulation of the parts. In the case of those with diabetes, many users will be of impaired vision and may also be physically infirm. Devices that are too large of cumbersome may therefore prove difficult to use, particularly someone with reduced dexterity.

Patent Specification U.S. Pat. No. 6,340,357 describes a drug delivery system in which the dose setting is read into an electronic circuit and the dose setting movement of the dose setting elements relative to each other is performed by an electromechanical device, e.g. a motor controlled by the electronic circuit in accordance with the read in dose setting. The electronic control enables the apparatus to intervene by resetting a dose if a miss-handling of the device by the user is detected during dose setting, such as opening of the cartridge holder.

Patent Specification WO 2007/094833 describes a metering system for automatically adjusting for differential thermal expansion/contraction for the efficient, accurate and reproducible metered delivery of fluids. The system allows the metering system drive to re-zero itself to produce an accurate volumetric delivery of fluid from the dispensing container.

It is also known to detect a stall of the motor that drives the dose delivery and to warn the user if a dose fails to be delivered. However, there remains a problem in the resetting of the device following detection of a motor stall event.

It is an aim of the present invention to provide a medication delivery device that alleviates this problem.

According to the present invention, there is provided an injection device for delivering a medicament to a patient, wherein the injector device comprises: a housing; a piston rod for driving a bung of a medicament container; a drive mechanism including a motor for providing an output drive to the piston rod for delivering the medicament; and control means for controlling operation of the device; characterised in that: the control means comprises: a drive signal generator for generating an input drive signal for the motor; an encoder for generating an encoder output signal indicative of the output

2

drive of the motor; and means for varying the operational control of the device in dependence on a comparison between the input drive signal and the encoder output.

The input drive signal may be stepper pulses for driving the motor. The encoder output signal may be a pulsed signal having a timing characteristic that corresponds to the output drive of the motor. A plurality of reference points may be included in the device, each reference point being indicative of a different operational aspect of the device, including any one or more of: backstop position; dose delivered; door position; drive position; and reset threshold. The reference points preferably relate to the input drive signal such that respective reference points correspond to respective counts of the stepper pulses with reference to a device datum. A comparison between counts of the pulsed encoder output with counts of the stepper pulses may be indicative of motor slip. In the event that motor slip or stall is detected the control means is operative for determining the quantum of slip relative to one of the reference points whereupon said varying means adjusts the operational control of the device according to a predetermined criteria. The variation in operation control may be such as to urge the device to a target operational state. For example, when the quantum exceeds a predetermined threshold value, the motor may be deliberately stalled against a predetermined reference point representative of the target state. For example, the motor drive may be varied so the state of the device is changed to a dose reset position or a 'cartridge door open state' for enabling replacement of the cartridge. Alternatively, the motor may be controlled such as to rewind the piston rod to a backstop which defines a device datum or device reset position.

Embodiments of the present invention are advantageous in that the injector automatically initiates a reset action when necessary and without needing user interaction. This leads to an improvement in battery life and an avoidance or reduction in motor stall noise.

BRIEF DESCRIPTION OF THE DRAWINGS

The invention will now be further described by way of example with reference to the accompanying drawings, in which like reference numerals designate like elements:

FIG. 1 is a front view of an auto-injector that may include an embodiment of the present invention;

FIG. 2 is a front view of the auto-injector of FIG. 1 with a medicament cartridge door shown in an open position for receiving a medicament cartridge;

FIG. 3 is a perspective view of a motor for use in embodiments of the present invention;

FIG. 4 is a side view of the motor of FIG. 3 with an encoder;

FIG. 5a is a timing chart of motor drive and encoder output; FIG. 5b is a timing chart of motor drive and encoder output showing motor slip;

FIG. 6 is a flow chart illustrating a decision sequence that may be performed by the control means; and

FIG. 7 is a functional block diagram of the control means.

DETAILED DESCRIPTION

In FIG. 1, an auto-injector 1 comprises a case 2 having a display 3 for displaying functional information relating to the operation of the auto-injector, including the set dose, number of doses remaining in the medicament cartridge. User interface buttons 4, 5 and 6 are provided to allow the user to operate the injector including priming, setting a dose, opening a medicament cartridge holder and door 7, and activating the dispensing of the set dose. A threaded needle attachment

3

8 is provided to which a needle can be attached for dose delivery and subsequently removed and discarded. A cover (not shown) may be provided to fit over the lower portion of the case 2 to assist in protect the device from the ingress of particles and fluid. FIG. 2 shows the auto-injector 1 with the cartridge holder and door 7 in an open position for receiving a replacement medicament cartridge 9.

FIG. 3 shows a motor 13 within a drive mechanism (see FIG. 7). The motor is provided with a pair of flags 15 disposed at 180 degrees with reference to one another. An output gear 17 engages with a gear train of the drive mechanism for driving the piston rod of the auto-injector 1. The motor 13 may be a stepping motor driven by a pulsed drive signal or stepper pulses illustrated schematically in FIGS. 5a and 5b below. The pulsed drive signal is generated by an electronic control circuit within the control means. The control means will be described in more detail with reference to FIGS. 5a to 7.

FIG. 4 is a side view of the motor 13 showing an optical encoder 19 in registration with the flags 15. As the drive shaft of the motor 13 rotates the flags 15, every edge of a flag causes a change in the output of the optical encoder 19, so that the encoder outputs a series of output pulses representative of the angular velocity of the drive shaft. The control means (microcontroller/microprocessor) detects and counts these pulses. The encoder signal causes an interrupt in the microcontroller/microprocessor. An interrupt causes an interruption of the current software program flow, executes a special interrupt software routine and returns to the normal software flow after finishing the interrupt routine. This technique is used to react immediately to external signals to make sure that every signal is recognized by the microprocessor. In the embodiment shown in FIG. 4, a pair of flags 15 is located at 180° and will therefore generate 4 pulses per motor turn. One encoder pulse is therefore equivalent to 5 motor pulses, assuming 20 motor pulses for a single turn of the motor shaft.

FIG. 5a illustrates the relative timing between the motor drive or stepper pulses and the encoder output pulses during normal drive mechanism movement of the device. In this example, there are 5 motor stepper pulses to one encoder output pulse, the control means being programmed to expect 5 motor stepper pulses to one encoder output pulse. Consequently, when 20 motor stepper pulses are counted at the same time that the control means counts 4 encoder output pulses, the control comparison determines that the device is driving normally. That is, there is no motor slippage or no motor stall.

FIG. 5a illustrates a situation where a count comparison between the encoder pulse output is such as to indicate 15 motor stepper pulses whereas the actual count by the control means corresponds to 19 or 20 pulses. In this case the control means determines from the comparison that the motor movement has encountered slippage. At this point, a subroutine is run by software programmed into the control means to make a determination as to the state of the auto-injector in relation to predetermined reference points and a device datum position. The position of the piston rod when in a fully retracted position may represent a backstop position or datum position (i.e. "zero") from which other device reference points may be referenced. The datum position also corresponds to an absolute motor position so that incremental movements relative to that correspond to other operational states of the device. These other device reference points are between zero and a maximum motor travel position through 26858 motor stepper pulses. For example, from the datum position, a medicament cartridge 9 door latch open position may be represented by, for example, a motor position that corresponds to "datum

4

position+4 pulses". A priming dose may be determined to have been effected by movement of the motor 13 through 84 pulses from the backstop datum position.

FIG. 6 shows an example of an administration routine that may be run with the control means software during the administration of medicament. At 60, the user inputs via input buttons 4-6 a desire to start the administration of a dose of medicament. The motor stepper and encoder pulse counts are examined at step 62 to determine if they differ from one another by more than a predetermined amount. If YES, the control means rewinds the drive mechanism until the motor stalls at the backstop, at which point the device may be datumed or reset. The control means software may then calculate the deficit in the medicament administered and perform means to administer this dose. If NO, the administration continues until the dose is completely expelled.

FIG. 7 is a functional block diagram of the control means 70, to which is connected a user input 72 corresponding to the user interface buttons 4-6 of FIG. 1, and the drive mechanism 74. The control means 70 includes dial buttons 76 through which the user can dial the required dose and an LC display 78 for displaying the set dose. The control means software sets a dose value corresponding to that set by the user at 80 and converts this into an appropriate pulse value for the stepper motor 13 at 82. At 84, the software determines the current position of the motor 13 by looking at the current pulse count of the stepper pulses generated by the motor and determines a motor target position 86 in terms of stepper pulses that corresponds to the reference point representative of the piston rod position that will deliver the dose set at 76/80. The control means software, motor control 88, generates the required stepper pulses to drive the motor 13 of the drive mechanism 74 and compares encoder and motor pulses.

The invention claimed is:

1. An injection device for delivering a medicament to a patient, wherein the injection device comprises:
 - a housing;
 - a piston rod for driving a bung of a replaceable medicament container, the piston rod retractable to a backstop position;
 - a drive mechanism including a motor for providing an output drive to the piston rod for delivering a user settable dose of the medicament and retracting the piston rod to the backstop position; and
 - a controller that controls operation of the device; wherein: the controller comprises:
 - a drive signal generator that generates an input drive signal for the motor;
 - an encoder that generates an encoder output signal indicative of the output drive of the motor;
 - wherein the controller varies the operational control of the device in dependence on a comparison between the input drive signal and the encoder output,
 - wherein the encoder output signal is a pulsed signal having a timing characteristic that corresponds to the output drive of the motor,
 - wherein a comparison between counts of the encoder output with counts of stepper pulses is indicative of motor stall or motor slip,
 - wherein the motor is deliberately stalled against a predetermined reference point when the quantum of slip exceeds a predetermined threshold value, and
 - wherein the controller calculates the deficit in the medicament administered and performs administration of this dose.

2. An injection device according to claim 1, wherein the input drive signal comprises stepper pulses for driving the motor.

3. An injection device according to claim 1, wherein a plurality of reference points are included in the device, each reference point being indicative of a different operational aspect of the device. 5

4. An injection device according to claim 3, wherein the reference points include any one or more of: backstop position; dose delivered; door position; drive position; and reset threshold. 10

5. An injection device according to claim 3, wherein the reference points relate to the input drive signal such that respective reference points correspond to respective counts of stepper pulses with reference to a device datum. 15

6. An injection device according to claim 3, wherein in an event that motor slip or stall is detected the controller is operative for determining a quantum of slip relative to one of the reference points whereupon said controller adjusts the operational control of the device according to a predetermined criteria. 20

* * * * *