



US009271377B2

(12) **United States Patent**
Velazquez

(10) **Patent No.:** **US 9,271,377 B2**
(45) **Date of Patent:** ***Feb. 23, 2016**

(54) **WIRELESS CONTROLLER FOR LIGHTING SYSTEM**

USPC 315/132, 292, 152
See application file for complete search history.

(71) Applicant: **AMERICAN DJ SUPPLY, INC.**, Los Angeles, CA (US)

(56) **References Cited**

(72) Inventor: **Toby Velazquez**, Yorba Linda, CA (US)

U.S. PATENT DOCUMENTS

(73) Assignee: **American DJ Supply, Inc.**, Los Angeles, CA (US)

6,761,470 B2 7/2004 Sid
7,277,024 B2 10/2007 Chen
7,405,523 B2 7/2008 Wilhelm et al.

(Continued)

(*) Notice: Subject to any disclaimer, the term of this patent is extended or adjusted under 35 U.S.C. 154(b) by 0 days.

This patent is subject to a terminal disclaimer.

OTHER PUBLICATIONS

International Search Report and Written Opinion dated Nov. 15, 2010 for International Application No. PCT/US2010/047911, pp. 1-12, United States Patent and Trademark Office, Virginia, United States.

(Continued)

(21) Appl. No.: **14/281,520**

Primary Examiner — Don Le

(22) Filed: **May 19, 2014**

(74) *Attorney, Agent, or Firm* — Sherman IP LLP; Kenneth L. Sherman; Hemavathy Perumal

(65) **Prior Publication Data**

US 2014/0292222 A1 Oct. 2, 2014

(57) **ABSTRACT**

Related U.S. Application Data

(63) Continuation of application No. 13/394,138, filed as application No. PCT/US2010/047911 on Sep. 3, 2010, now Pat. No. 8,766,544.

The present invention provides a system and method for controlling at least one lighting system by means of a portable wireless remote control device. The system comprises a portable wireless remote control device, a lighting system controller, and at least one lighting system coupled to the lighting system controller. Each lighting system comprises one or more lighting modules (e.g., light emitting diodes (LEDs), incandescent bulbs, etc.). The portable wireless remote control device comprises a wireless transceiver, processor, memory, light control logic, user interface (UI), and an antenna. The lighting system controller comprises a wireless transceiver, processor, memory, light control logic, and an antenna. Each lighting system coupled (e.g., wired) to the lighting system controller may be wirelessly controlled via the remote control device.

(60) Provisional application No. 61/240,070, filed on Sep. 4, 2009.

(51) **Int. Cl.**
H05B 37/02 (2006.01)

(52) **U.S. Cl.**
CPC **H05B 37/0272** (2013.01)

(58) **Field of Classification Search**
CPC H05B 37/02

30 Claims, 7 Drawing Sheets

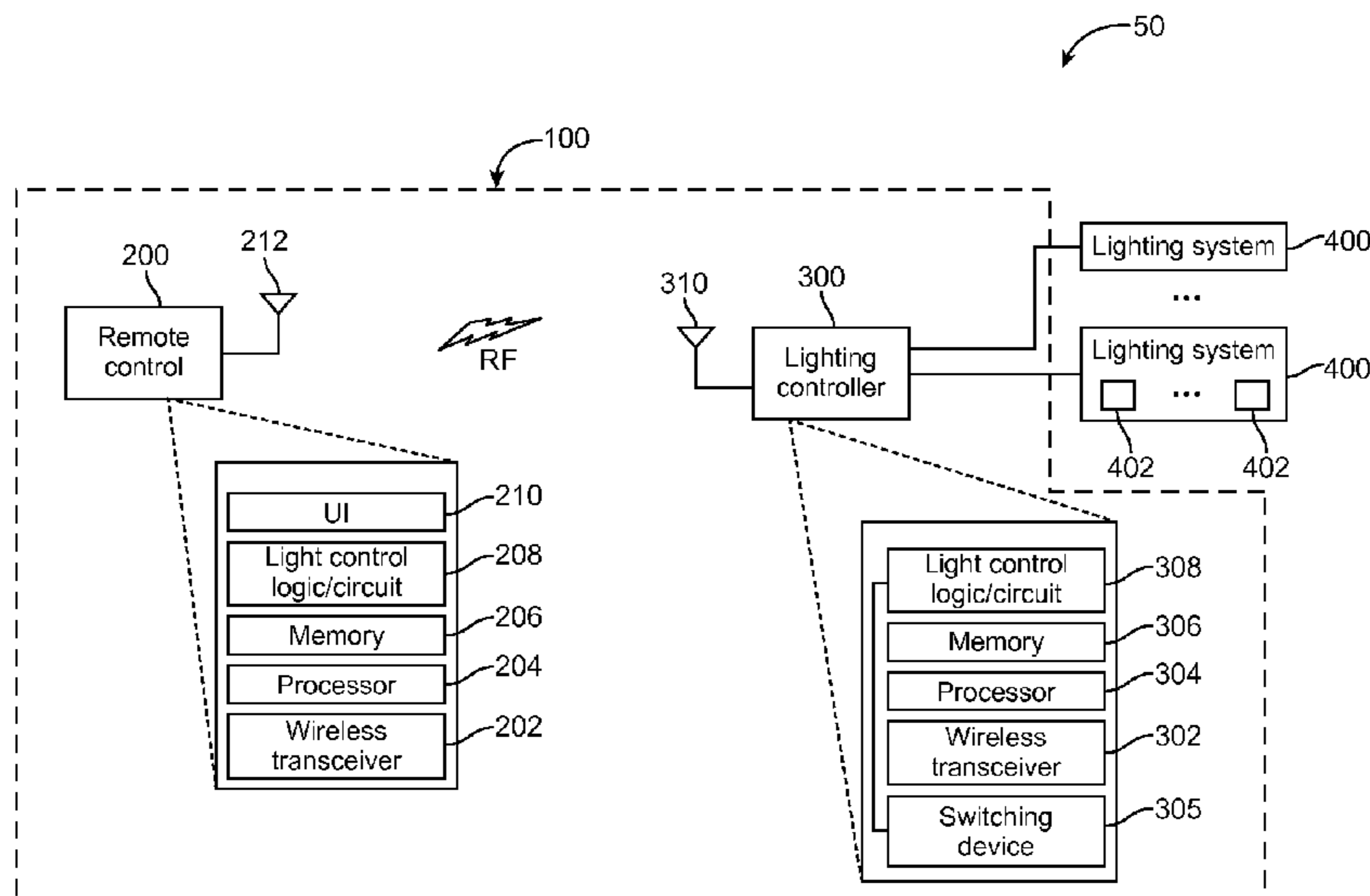

(56)

References Cited

U.S. PATENT DOCUMENTS

7,498,952	B2 *	3/2009	Newman, Jr.	340/815.45
2006/0187083	A1	8/2006	Lee et al.	
2007/0211461	A1 *	9/2007	Harwood	362/232
2007/0229250	A1 *	10/2007	Recker et al.	340/531
2007/0273539	A1 *	11/2007	Gananathan	340/615
2010/0045205	A1	2/2010	Bergman et al.	
2010/0327766	A1	12/2010	Recker et al.	
2011/0031889	A1 *	2/2011	Shim	315/158
2011/0187271	A1	8/2011	Bouws et al.	
2012/0098432	A1	4/2012	Recker et al.	
2012/0223646	A1	9/2012	Recker et al.	

OTHER PUBLICATIONS

International Preliminary Report on Patentability and Written Opinion dated Mar. 15, 2012 for International Application No. PCT/US2010/047911 from International Bureau of WIPO, pp. 1-7, Geneva, Switzerland.

U.S. Non-Final Office Action mailed Sep. 24, 2013 for U.S. Appl. No. 13/394,138.

U.S. Notice of Allowance mailed Feb. 18, 2014 for U.S. Appl. No. 13/394,138.

* cited by examiner

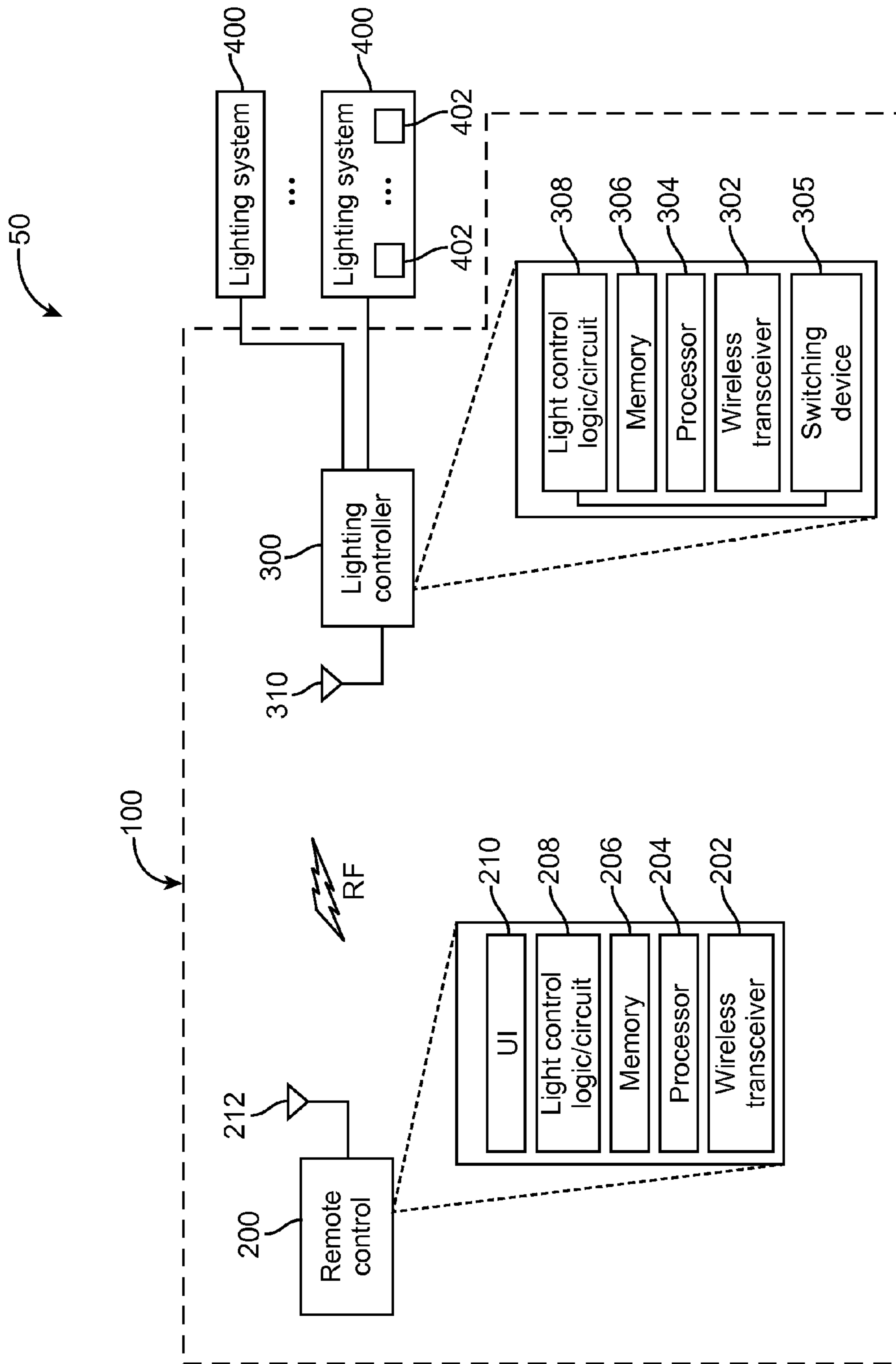

FIG. 1

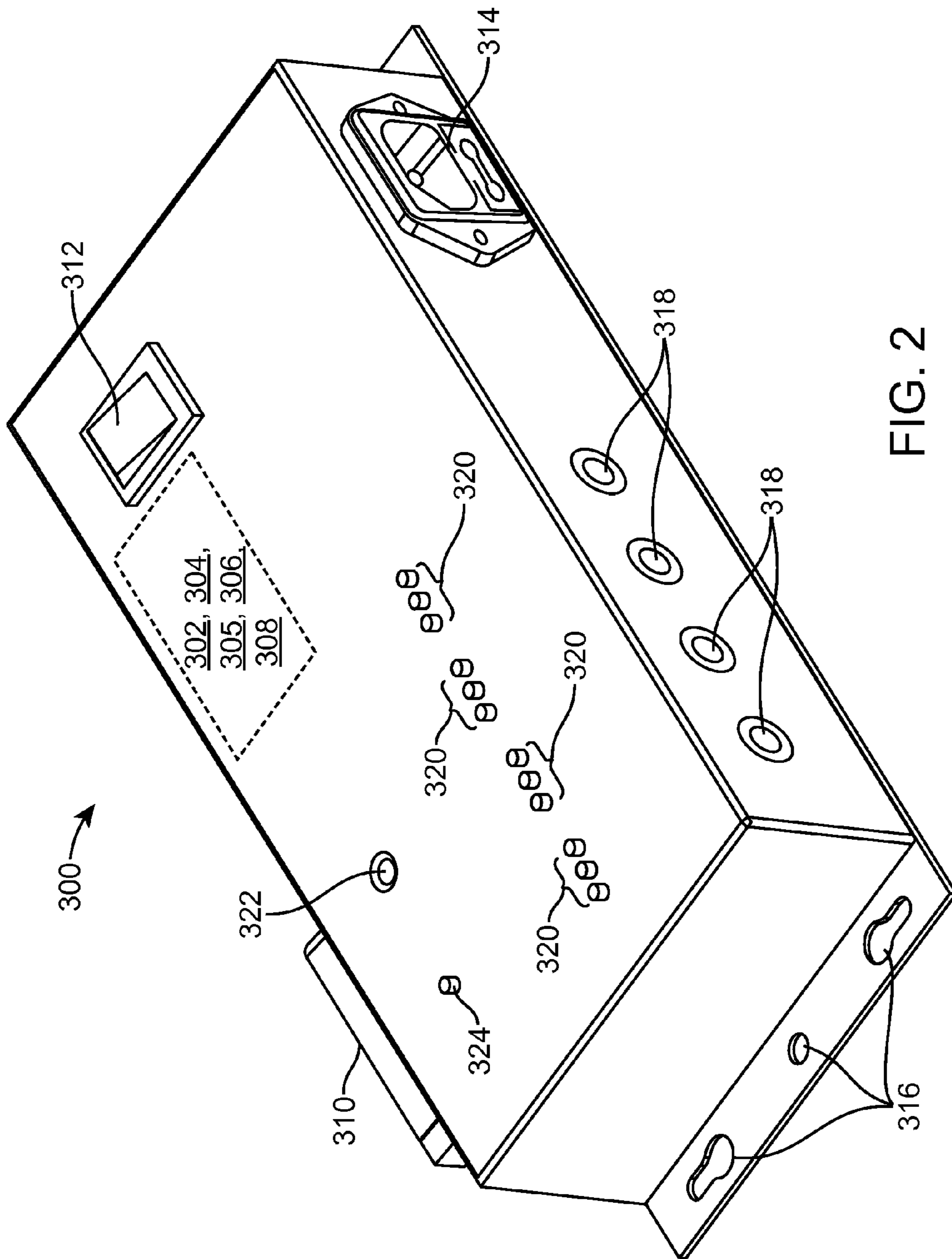

FIG. 2

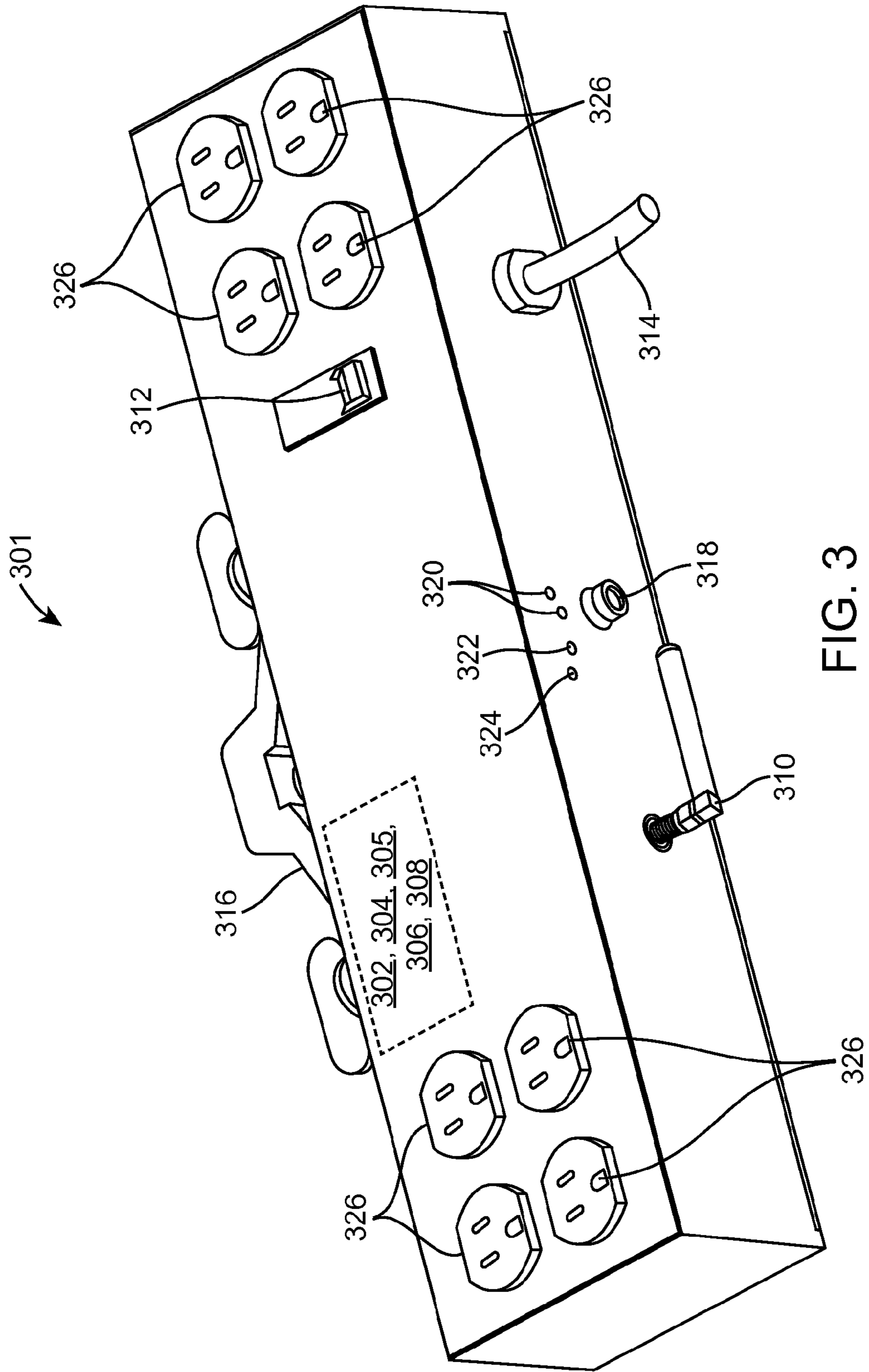

FIG. 3

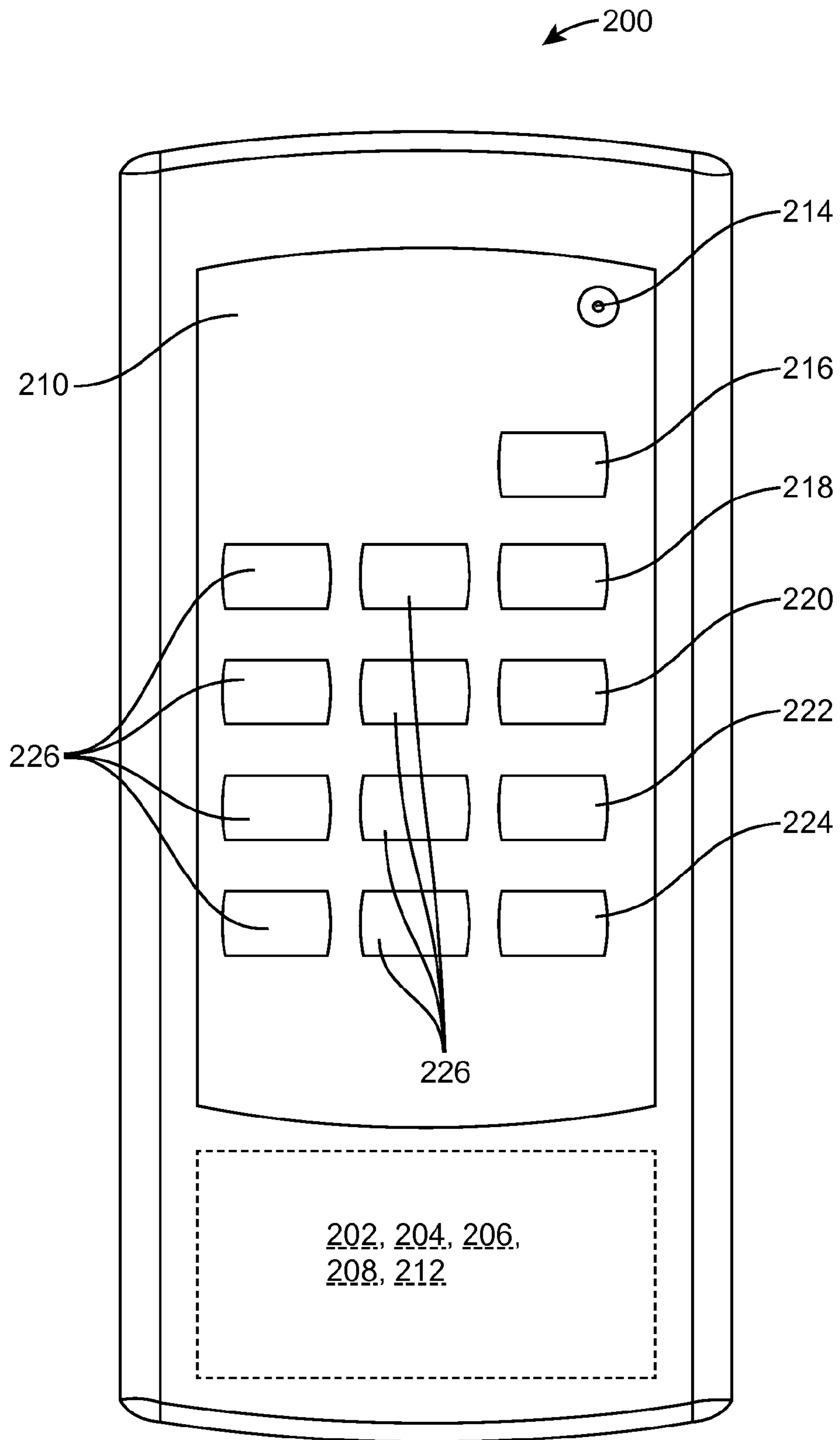

FIG. 4

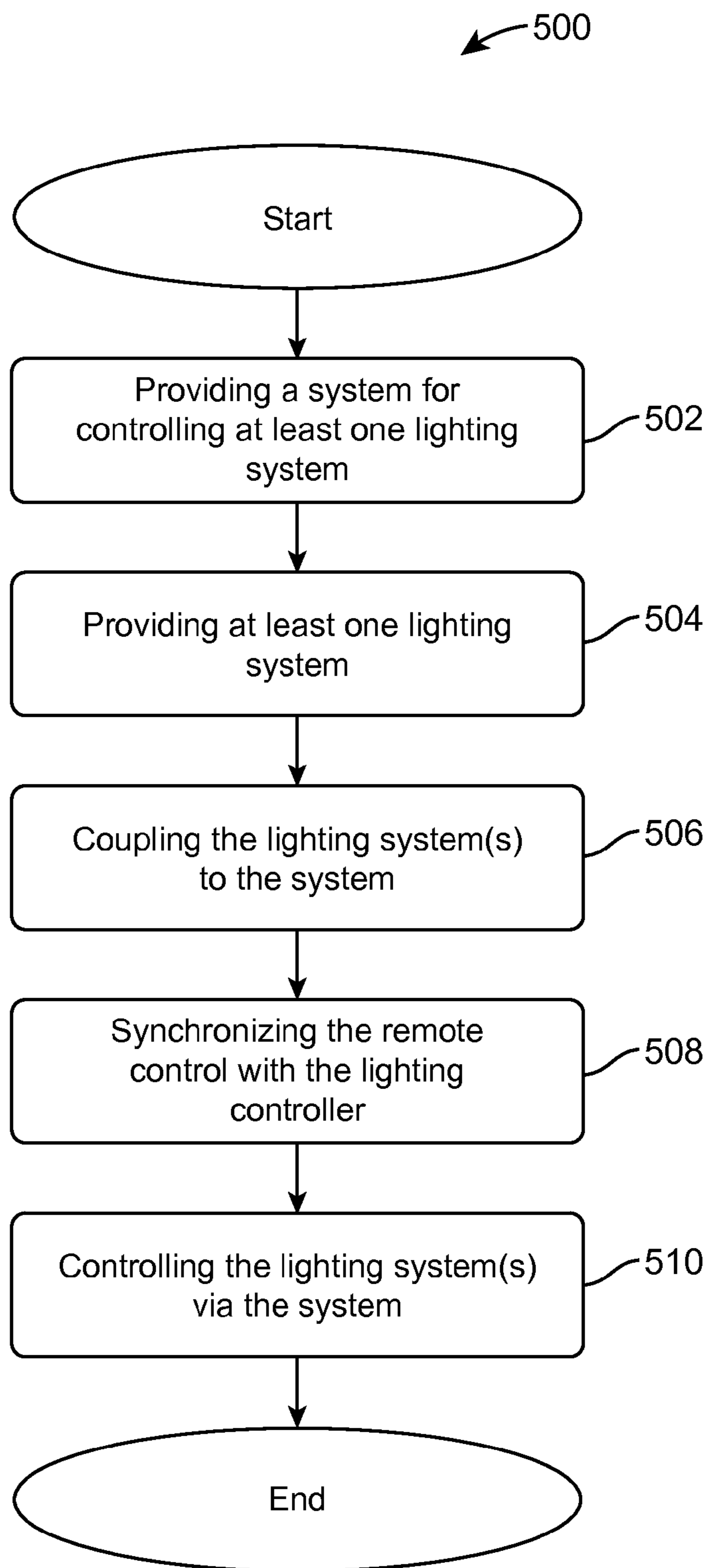

FIG. 5

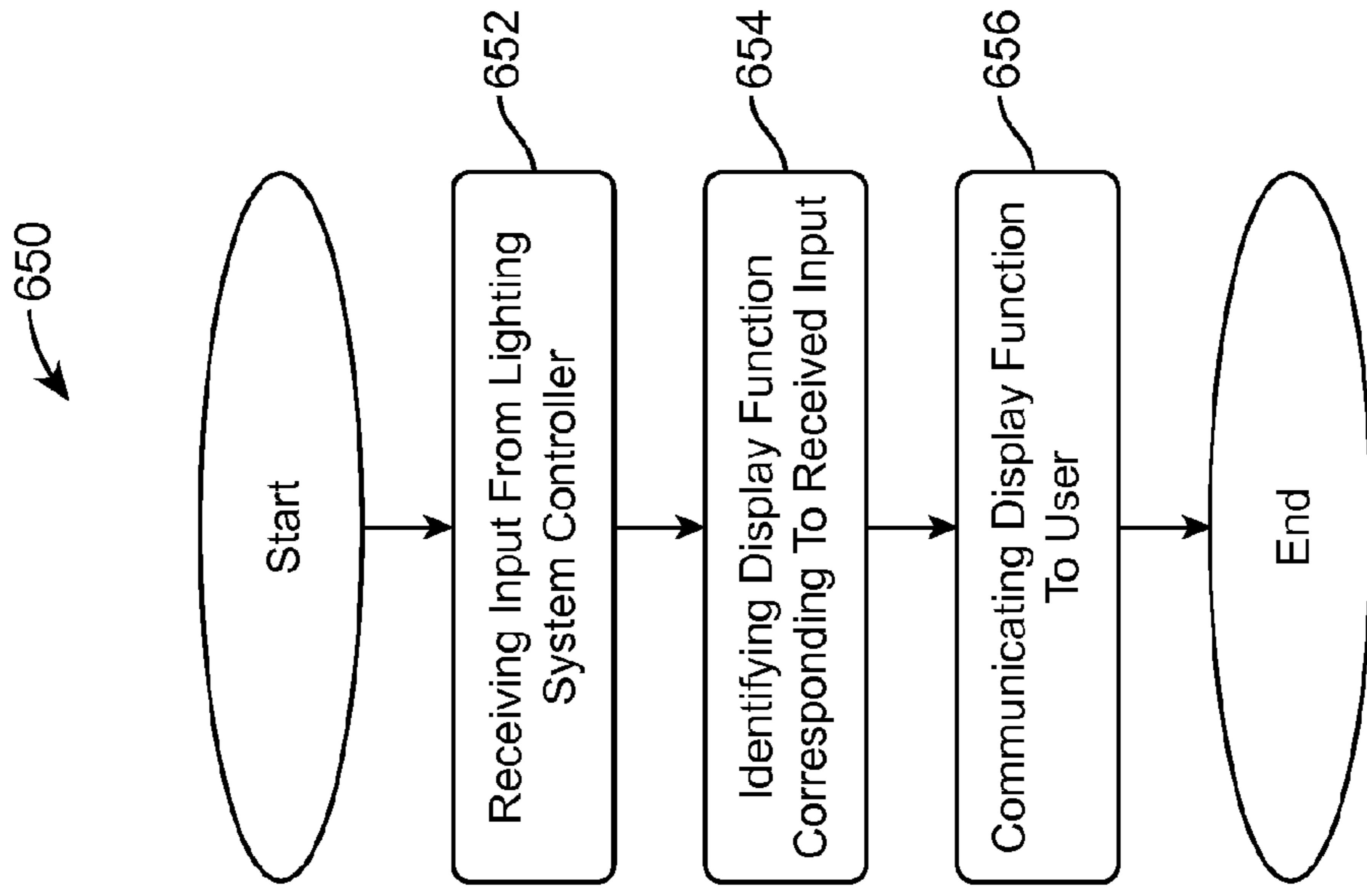

FIG. 6B

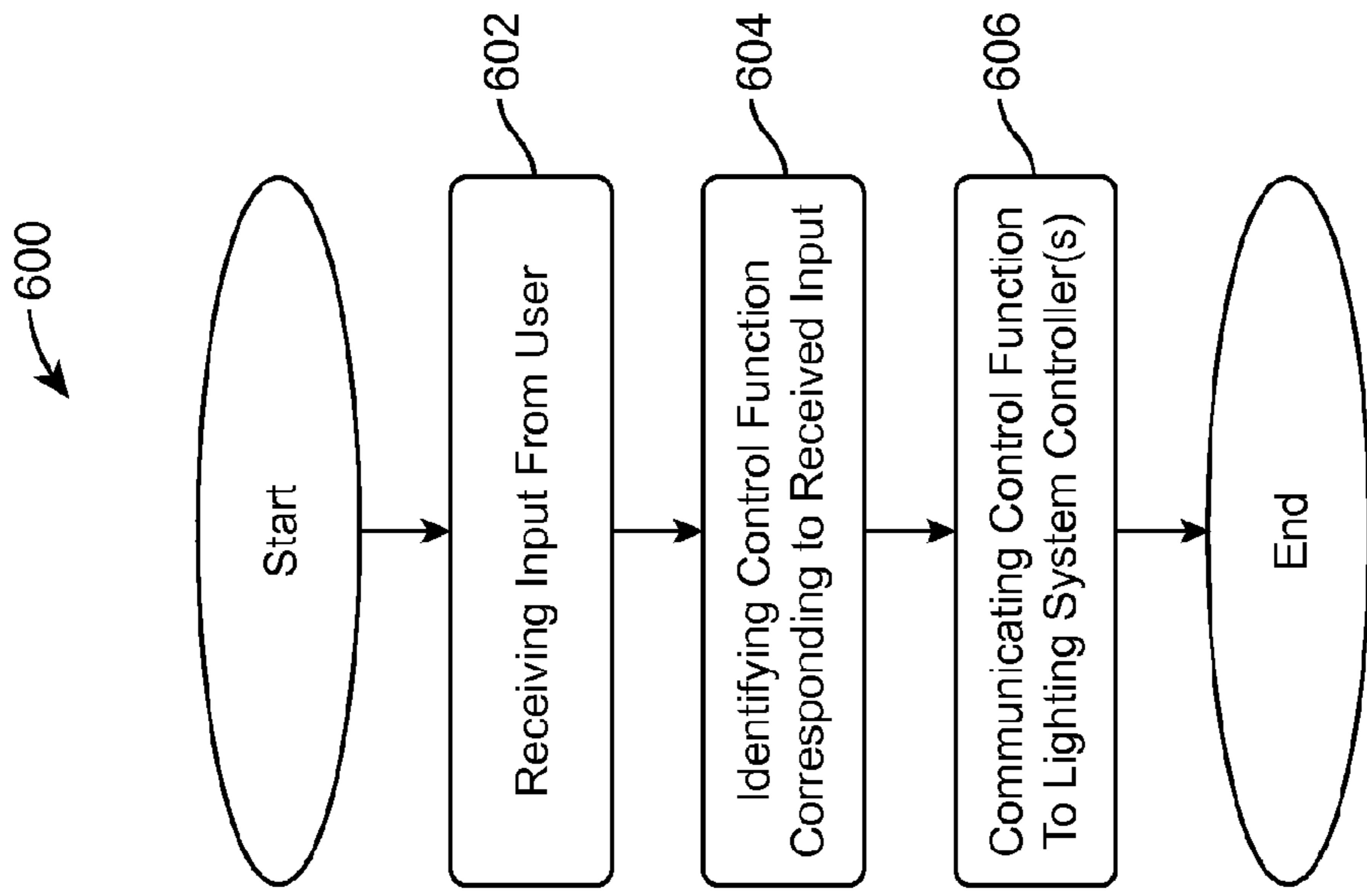

FIG. 6A

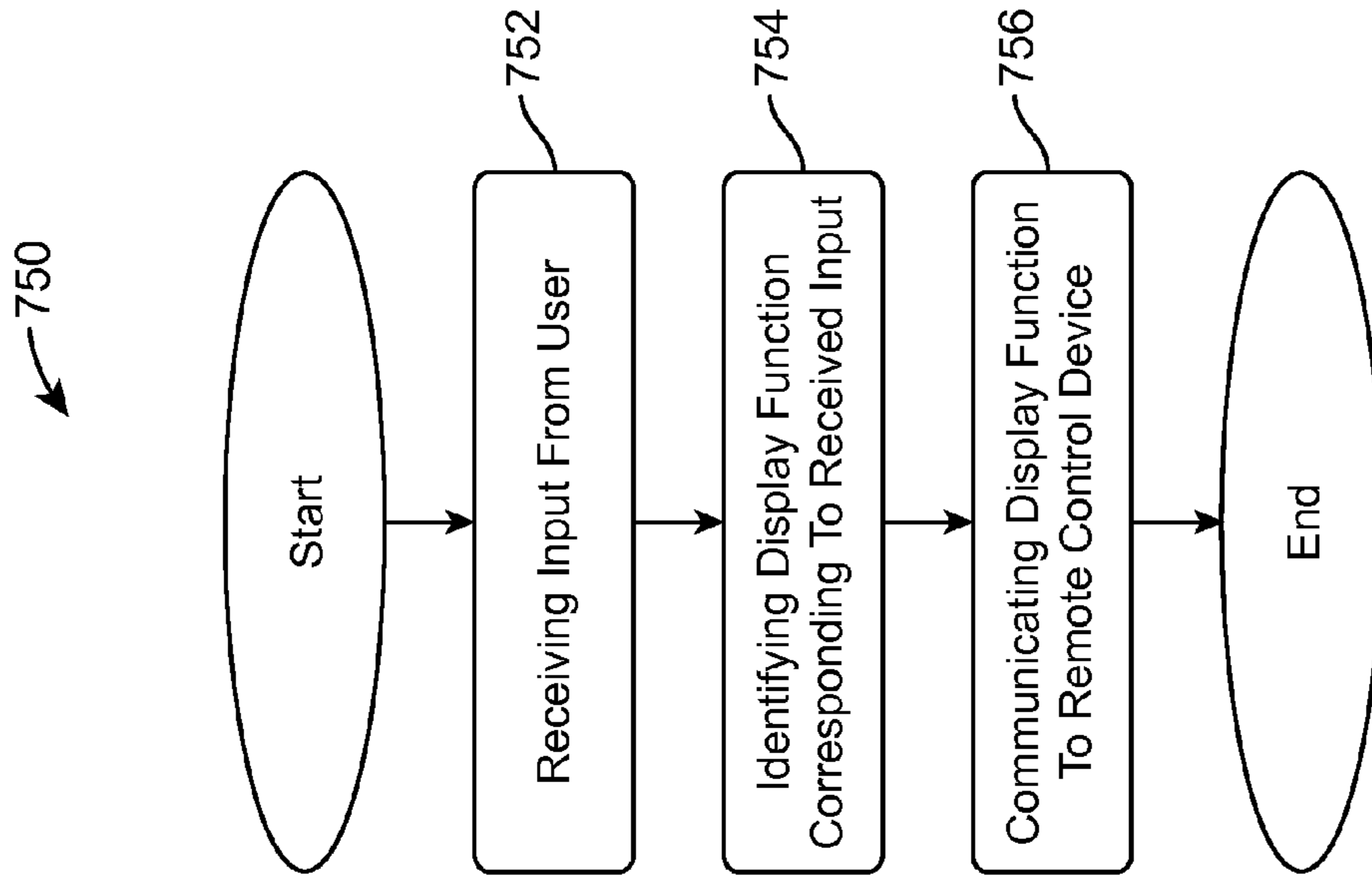

FIG. 7B

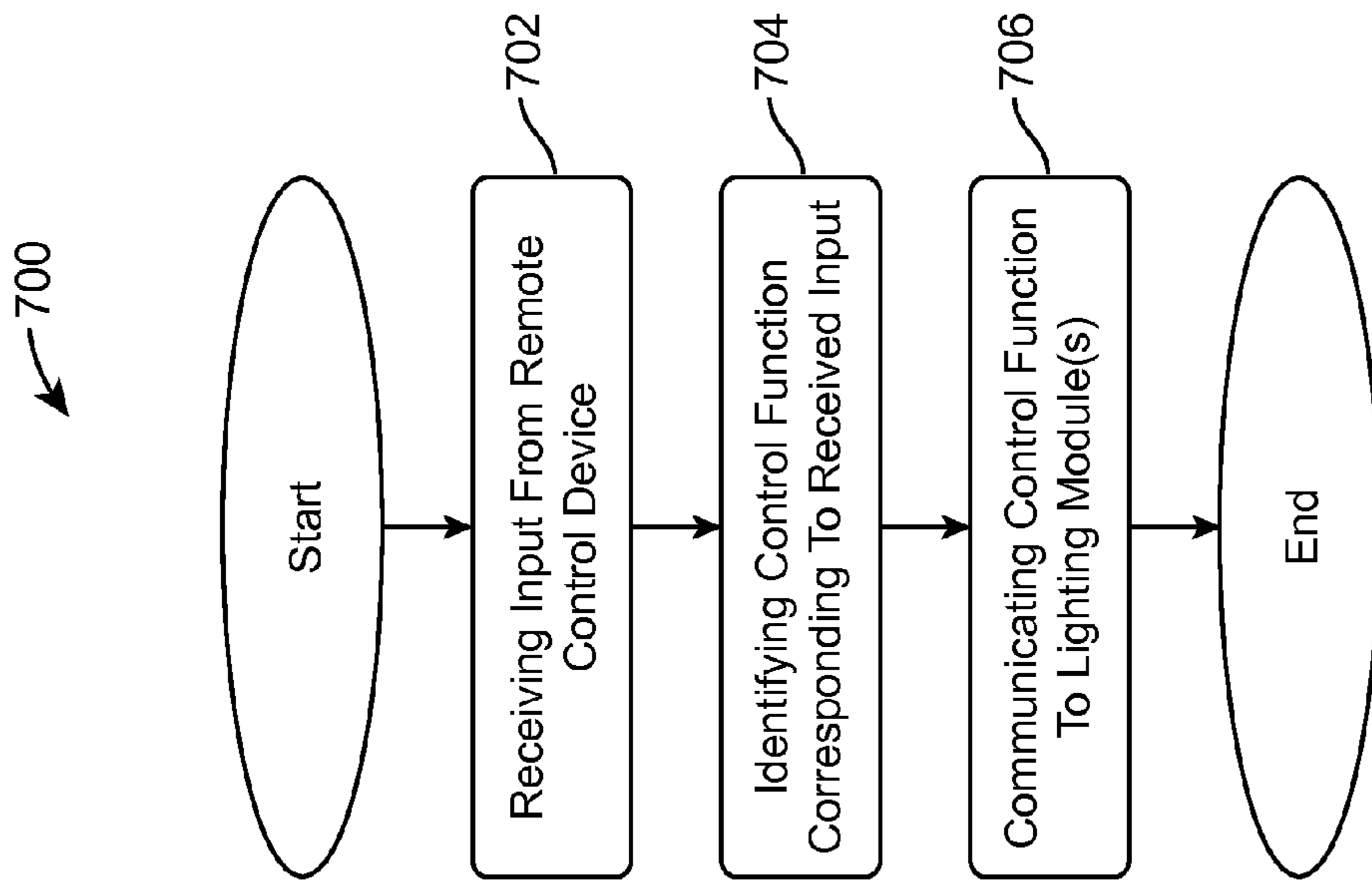

FIG. 7A

WIRELESS CONTROLLER FOR LIGHTING SYSTEM

CROSS REFERENCE TO RELATED APPLICATIONS

The present application is a continuation of and claims priority to U.S. patent application Ser. No. 13/394,138 filed on Mar. 2, 2012, which in turn is the U.S. National Phase Patent Application under 35 U.S.C. §371 of International Application Number PCT/US2010/047911 filed on Sep. 3, 2010. International Application Number PCT/US2010/047911 claims priority to U.S. Provisional Patent Application Ser. No. 61/240,070 filed on Sep. 4, 2009. U.S. patent application Ser. No. 13/394,138, International Application Number PCT/US2010/047911 and U.S. Provisional Patent Application Ser. No. 61/240,070 are incorporated herein by reference in their entirety.

BACKGROUND OF THE INVENTION

1. Field of the Invention

The present invention relates generally to wireless controllers, and in particular, to a wireless controller for lighting systems.

2. Background of the Invention

Lighting fixtures are used for illuminating environments such as indoor spaces. A typical lighting fixture comprises a housing including a socket for receiving a lighting element such as a light bulb, wherein the socket provides electrical power to the lighting element. Each lighting fixture may be independently installed on a support or mounting surface and coupled to an electrical power source via electrical cables for powering the lighting elements.

BRIEF SUMMARY OF THE INVENTION

The present invention provides a system and method for controlling at least one lighting system by means of a portable wireless remote control device. In one embodiment, the system comprises a portable wireless remote control device, a lighting system controller, and at least one lighting system. Each lighting system comprises one or more lighting modules (e.g., light emitting diodes (LEDs), incandescent bulbs, neon lamps, fluorescent lamps, etc.).

In one embodiment, the portable wireless remote control device comprises a wireless transceiver, processor, memory, light control logic, user interface (UI), and an antenna. The portable wireless remote control device may communicate wirelessly (e.g., radio frequency, infrared frequency, etc.) with the lighting system controller. In a particular embodiment, the user interface is a keypad comprising an indication LED, an all-on button, an all-off button, a standby button, a function button, a mode button, and a plurality of on/off buttons; all for controlling lighting systems coupled to the lighting system controller.

In one embodiment, the lighting system controller comprises a wireless transceiver, processor, memory, light control logic, and an antenna. The lighting system controller may further comprise a means for removably coupling the lighting controller to a surface, at least one output jack for controlling a lighting system coupled thereto, and at least one bank of indication light emitting diodes (LEDs) for indicating a status of each lighting system coupled to the lighting controller. Each lighting system is coupled (e.g., wired) to the lighting system controller and may be powered either by the lighting

system controller or an alternative source (e.g., electrical outlet, generator, solar cell, battery, etc.).

These and other features, aspects and advantages of the present invention will become understood with reference to the following description, appended claims and accompanying figures.

BRIEF DESCRIPTION OF THE DRAWINGS

FIG. 1 illustrates a diagram of a wireless controller for a lighting system, according to an embodiment of the present invention.

FIG. 2 illustrates a perspective view of a lighting system controller, according to an embodiment of the present invention.

FIG. 3 illustrates a perspective view of an alternative lighting system controller, according to an embodiment of the present invention.

FIG. 4 illustrates a view of a portable remote control, according to an embodiment of the present invention.

FIG. 5 illustrates a process for controlling at least one lighting system, according to an embodiment of the present invention.

FIG. 6A illustrates an alternative process for controlling at least one lighting system, according to an embodiment of the present invention.

FIG. 6B illustrates an alternative process for controlling at least one lighting system, according to an embodiment of the present invention.

FIG. 7A illustrates an alternative process for controlling at least one lighting system, according to an embodiment of the present invention.

FIG. 7B illustrates an alternative process for controlling at least one lighting system, according to an embodiment of the present invention.

DETAILED DESCRIPTION OF THE INVENTION

The following description is made for the purpose of illustrating the general principles of the present invention and is not meant to limit the inventive concepts claimed herein. Further, particular features described within can be used in combination with other described features in each of the various possible combinations and permutations. Unless otherwise specifically defined herein, all terms should be given their broadest possible interpretation including meanings implied from the specification as well as meanings understood by those skilled in the art and/or as defined in dictionaries, treatises, etc.

Embodiments of the invention provide a control system for controlling at least one lighting system. In one embodiment, the control system comprises a lighting controller electrically coupled to each lighting system and a remote control device configured for transmitting control signals to the lighting controller. The lighting controller is configured for receiving control signals from the remote control device and controlling operation of each coupled lighting system based on control signals from the remote control device. In one embodiment, the remote control device transmits control signals to the lighting controller via a wireless communication medium.

Referring now to the embodiments of the invention shown in the drawings, FIG. 1 illustrates a system **100** for controlling at least one lighting system **400** by means of a portable wireless remote control device **200**, according to an embodiment of the present invention. The system **100** comprises a portable wireless remote control device **200** and a lighting system controller **300**. In one embodiment, an apparatus **50** com-

prises the system 100 and at least one lighting system 400 electrically coupled to the lighting system controller 300. Each lighting system 400 comprises one or more lighting modules 402 (e.g., light emitting diodes (LEDs), incandescent bulbs, neon lamps, fluorescent lamps, etc.).

In one embodiment of the present invention, the portable wireless remote control device 200 comprises a wireless transceiver 202, processor 204, memory 206, light control logic 208, user interface (UI) 210 (e.g., keypad), and an antenna 212. The portable wireless remote control device 200 communicates with the lighting system controller 300 over a wireless communication medium (e.g., radio frequency (RF), infrared frequency, etc.).

As illustrated in FIG. 1, the lighting system controller 300 comprises a wireless transceiver 302, processor 304, memory 306, light control logic 308, and an antenna 310. Each lighting system 400 is coupled (e.g., wired) to the lighting system controller 300 and may be powered either by the lighting system controller 300 or an alternative source (e.g., electrical outlet, generator, solar cell, battery, etc.).

In one embodiment, the lighting controller 300 includes an electrical switching device (circuit) 305 that is controlled by the control circuit 308 for selectively switching electrical power to each lighting system 400 based on user commands from the remote control device 200. In the example shown in FIG. 2, the electrical switching device 305 is connected between the electrical power input 314 and the power outlets 318 for selectively switching electrical power to each coupled lighting system 400. In the example shown in FIG. 3, the electrical switching device 305 is connected between the electrical power input 314 and the power outlets 326 for selectively switching electrical power to each coupled lighting system 400.

FIG. 2 illustrates a perspective view of a lighting system controller 300, according to an embodiment of the present invention. In this embodiment the controller 300 is essentially rectangular in shape and houses the wireless transceiver 302, processor 304, memory 306, and light control logic/circuits 308. The controller 300 also comprises the antenna 310, a power switch 312, a power cord inlet 314, and coupling member 316 (e.g., apertures) for attaching the lighting system controller 300 to a surface (e.g., wall, ceiling, etc.) via coupling means such as screws, nuts/bolts, etc. In this embodiment the power cord inlet 314 is designed to receive a removable power cord, however it is appreciated that in alternative embodiments a non-removable power cord may be used. The power switch 312 provides a means for turning on/off the lighting system controller 300. The antenna 310 provides the means for communicating with the portable wireless remote control device 200 (FIG. 1).

Moreover, the lighting system controller 300 comprises a plurality of output jacks 318, a plurality of indication light emitting diodes (LEDs) 320, a reset button 322, and a reset indication LED 324. Each output jack in the plurality of output jacks 318 is capable of connecting and controlling at least one lighting system thereto. Each bank of indication LEDs 320 illuminate to indicate the activity status for a given output jack 318. For example, the indication LEDs 320 may identify when a given lighting system is turned on and/or active, when the lighting system is in standby mode, when instructions are being sent to the lighting system, etc. The reset button 322 provides a means of synchronizing the lighting system controller 300 with the portable wireless remote control device 200 (FIG. 1). The reset indication LED provides an indication that the lighting system controller 300 and the portable wireless remote control device are in the process of synchronizing.

In this embodiment, each lighting system connected to the lighting system controller 300 via the output jacks 318 is powered by an external source. In an alternative embodiment, each output jack 318 is also capable of providing power to the lighting system as well as control instructions/signals.

The lighting system controller 300 may be located proximate the lighting systems 400 (e.g., attached to the ceiling near a lighting system, on the same truss component as the lighting system, etc.), wherein an operator (user) may send wireless signals to the lighting system controller 300 via the portable remote control device 200 from a distance without the need for wires/cables running between the remote control 200 and the lighting system controller 300. The portable remote control device 200 allows wireless control (via the lighting system controller 300) one or more lighting systems 400 (FIG. 1) individually or at the same time.

In one embodiment of the present invention, the lighting controller system 300 wirelessly transmits signals comprising status signals back to the portable remote control device 200 (FIG. 1), wherein the status signals may indicate the status of the various lighting systems 400 and or lighting modules 402 (FIG. 1).

In another embodiment of the present invention, each lighting system 400 (FIG. 1) may have a dedicated lighting controller system 300, wherein the lighting controller 400 may be a component part of the lighting controller system 300. As such, a single remote control 200 (FIG. 1) may be used to transmit control function codes to multiple lighting controller systems 300.

In yet another embodiment of the present invention, each lighting system 400 may include logic/programming of lighting sequences for the lighting modules 402 contained therein (FIG. 1). In this scenario, the coupled lighting controller system 300 provides control signals (based on function codes received from the remote control 200) to the lighting system to invoke different lighting programs in the lighting system 400 (desired by an operator of the remote control 200).

FIG. 4 illustrates a view of a portable remote control device 200, according to an embodiment of the present invention. The device 200 is essentially rectangular in shape and comprises the wireless transceiver 202, processor 204, memory 206, lighting control logic/circuits 208, and user interface (UI) 210 in a keypad configuration. In this embodiment, the user interface (UI) 210 comprises an indication LED 214, an all-on button 216, and all-off button 218, a standby button 220, a function button 222, a mode button 224, and a plurality of power jack on/off buttons 226.

The indication LED 214 is designed to blink when a command from the portable wireless controller device 200 has been sent to the lighting system controller 300. The all-on button 216 is designed to turn on all lighting systems connected to the lighting system controller 300 via a power jack 326. The all-off button 218 is designed to turn off all lighting systems connected to the lighting system controller 300 via a power jack 326. The standby button 220 is designed to set all of the lighting systems connected to the lighting system controller 300 via an output jack 318 to a blackout/standby mode.

The function button 222 is designed to cycle through each function (e.g., standby, sound activated, active, etc.) a given lighting system possesses, said lighting system being connected to the lighting system controller 300 via an output jack 318. The mode button 224 is designed to cycle through each mode (e.g., solid, strobe, pattern, etc.) a given lighting system possesses, said lighting system being connected to the lighting system controller 300 via an output jack 318. Finally, the plurality of power jack on/off buttons 226 are designed to turn

on and/or off each individual lighting system connected to the lighting system controller **300** via a power jack **326**.

The remote control user interface (UI) **210** may alternatively include a display device (e.g., indicator lights, display screen, etc.) to display the received status information in addition to the indication LED **214**. The remote control UI **210** may include other input devices instead of, or in addition to, the keypad embodiment illustrated in FIG. 4. Such other input devices may include joy stick, track ball, touch pad, touch screen, etc., for sending control function codes from the remote control **200** to the lighting controller system **300**.

With respect to the portable remote control device **200**, the lighting control logic/circuits **208** may maintain a look-up table in memory **206** which includes an entry for each key in the user interface (UI) **210**, each entry including a key number and a unique control function code. Activating a key causes an associated control function code to be selected and wirelessly transmitted from the portable remote control device **200** to the lighting system controller **300**. The lighting system controller **300** receives the control function code from the portable wireless controller **200**, and based on the received control function code, the lighting control logic/circuits **308** sends corresponding lighting control signal to a coupled lighting system **400** (FIG. 1).

Each lighting control signal may comprise a sequence or set of signals that controls operation of one or more lighting modules **402** of the lighting system **400** (FIG. 1). For example, a lighting control signal may comprise a programmed sequence of signals for changing on/off status of a first lighting module **402** every N seconds, and changing on/off status of a second lighting module **402** every M seconds, etc. In this example, the lighting control logic/circuits **308** of the lighting controller device **300** includes the various programming of lighting sequences for the lighting modules **402** for desired lighting patterns (FIG. 1).

FIG. 3 illustrates a perspective view of an alternative lighting system controller **301**, according to an embodiment of the present invention. In this embodiment the lighting system controller **301** is essentially rectangular in shape and comprises the wireless transceiver **302**, processor **304**, memory **306**, and light control logic/circuits **308** as in the lighting system controller **300** in FIG. 1. FIG. 3 further illustrates the antenna **310**, power switch **312**, power cord inlet **314**, and coupling member **316** (e.g., bracket) for attaching the lighting system controller **301** to a surface (e.g., wall, ceiling, truss system, etc.). In this embodiment the power cord **314** is non-removable by design.

The lighting system controller **301** comprises a single output jack **318**, two indication light emitting diodes (LEDs) **320**, a reset button **322**, and a reset indication LED **324**. The single output jack **318** is capable of connecting and controlling at least one lighting system thereto. The two indication LEDs **320** light up to indicate the activity status for the lighting system controller **301**. For example, the indication LEDs **320** may identify when the system controller **301** is turned on and/or active, when the lighting system controller **301** is in standby mode, etc. In this embodiment, each lighting system connected to the lighting system controller **301** via the output jack **318** is powered by an external source. In an alternative embodiment, the output jack **318** is also capable of providing power to the lighting system as well as control instructions/signals. This alternative embodiment also features a plurality of power jacks **326** capable of providing electrical power to at least eight separate lighting systems.

In another example, a single portable remote control device **200** may be used to selectively transmit control function codes to multiple lighting controller systems. For example,

the remote control UI **210** may include a selector button to select which lighting controller systems **300** and **301** should control function codes being transmitted (one at a time, or simultaneously).

FIG. 5 illustrates a process **500** for controlling at least one lighting system **400** using a remote control device **200** and lighting controller system such as the control lighting system controller **300** in FIG. 1 and the control lighting system controller **301** in FIG. 3, according to embodiments of the present invention. The process **500** begins with process block **502** which comprises providing a system **100** for controlling the lighting system(s) **400** (FIG. 1). The system **100** provided in process block **502** comprises a portable wireless remote control device **200** and a lighting system controller **300**.

Process block **504** which comprises providing at least one lighting system **400**. In one embodiment of the present invention, the lighting system **400** provided according to process block **504** comprises one or more lighting module **402** (e.g., light emitting diodes (LEDs), incandescent bulbs, neon lamps, fluorescent lamps, etc.).

In one embodiment of the present invention, process block **506** comprises coupling each lighting system **400** to an output jack **318** located on the lighting system controller **300** (FIG. 2). In an alternative embodiment of the present invention, process block **506** comprises coupling each lighting system **400** to a power jack **326** located on the lighting system controller **301** (FIG. 3). Process block **506** is complete after coupling the lighting system(s) **400** to the lighting system controller.

In one embodiment of the present invention, synchronizing the remote control device **200** with the lighting system controller **300** as per process block **508** comprises turning on the lighting system controller **300** via the power switch **312** (FIG. 2). After the controller is turned on, the reset button **322** on the controller **300** is pressed whereupon the reset indication LED **324** begins to flash (FIG. 2). After the reset indication LED **324** begins flashing, any button in the keypad user interface (UI) of the wireless remote control device **200** may be pressed (FIG. 4). Upon pressing a button on the wireless remote control device **200**, the indication LED **324** on the lighting controller **300** turns off to indicate that synchronization is successful (FIG. 2). In an alternative embodiment, the reset indication LED **324** may remain on instead of flashing (FIG. 2).

In one embodiment of the present invention, process block **510** comprises controlling the lighting system(s) **400** via the wireless remote control device **200** (FIG. 4). Controlling the lighting system(s) **400** utilizes the user interface (UI) of the remote control device **200** (FIG. 4). In one embodiment, the remote control device **200** user interface (UI) is in a keypad configuration (FIG. 4). Controlling the lighting system(s) **400** may comprise turning on all lighting systems connected to the lighting system controller **300** by pressing the all-on button **216** (FIG. 4). Turning off all the lighting systems may be performed by pressing the all-off button **218** (FIG. 4). Pressing the standby button **220** on the remote control device **200** sets all lighting systems **400** coupled to the lighting system controller **300** to a blackout/standby mode (FIG. 4).

In one embodiment of the present invention, pressing the function button **222** on the remote control device **200** controls the lighting systems **400** by cycling through each function (e.g., standby, sound activated, active, etc.) a given lighting system **400** possesses (FIG. 4). Pressing the mode button **224** on the remote control device **200** controls the lighting systems **400** coupled to the lighting system controller **300** by cycling through each mode (e.g., solid, strobe, pattern, etc.) a given lighting system possesses (FIG. 4). Additionally, the lighting

system(s) **400** may be individually turned on and/or off by pressing a corresponding on/off button **226** on the wireless remote control device **200** (FIG. 4).

FIG. 6A illustrates flowchart of a process **600** providing example details of the control process **510** (FIG. 5) for controlling at least one lighting system **400** (FIG. 1), according to an embodiment of the present invention. Process block **602** comprises the remote control device **200** (FIG. 1) receiving input from a user. The process **600** may be implemented by the control logic **208**, according to an embodiment of the invention.

The remote control device **200** receiving input from a user may comprise, for example, a user pressing a button on a keypad on the remote control device **200** (FIG. 4). Alternatively, input from the user may comprise the user pressing multiple buttons on the remote control device **200** (FIG. 4), speaking into a microphone located on the remote control device **200**, etc.

Process block **604** comprises the remote control device **200** identifying a specific control function corresponding to the input received from the user. In one embodiment, each button in the keypad configured user interface **210** maps to a corresponding control function in a look-up table stored in memory **206** (FIG. 1). In one example, process block **604** uses the processor **204** and/or control logic/circuits **208** in the remote control device **200** to identify the specific control function in the look-up table in memory **206** that corresponds to the input received from the user (FIG. 1).

Process block **606** comprises the remote control device **200** communicating the identified control function to at least one lighting system controller such as the lighting system controller **300** (FIG. 1). In one embodiment, the wireless transceiver **202** utilizes the antenna **212** to wirelessly communicate the identified control function to the lighting system controller **300** (FIG. 1).

Further, the remote control device **200** may wirelessly receive information from each lighting system controller **300**. FIG. 6B illustrates a flowchart of such a process **650** for controlling **510** (FIG. 5) at least one lighting system **400** (FIG. 1), according to an embodiment of the present invention. Process **652** comprises the remote control device **200** receiving information from a lighting system controller **300**.

In one embodiment, input from the lighting system controller **300** is received by the antenna **212** and interpreted using the wireless transceiver **202** and processor **204** (FIG. 1). Such information may include, for example: acknowledgment from the lighting system controller **300** in response to a control signal sent from the remote control device **200** (e.g., control signal received, error, etc.), the status of the lighting system controller **300**, the status of one or more lighting systems **400** electrically coupled to the lighting system controller **300**, the status of one or more lighting elements **402**, etc. (FIG. 1).

The remote control device **200** may display information based on said information received from the remote control system **300**. For example, process block **654** comprises identifying a specific display information corresponding to the information received from the lighting system controller **300** (FIG. 1). In one embodiment, each button in the keypad **210** is capable of displaying a certain pattern(s) (e.g., flash, blink, strobe, solid color, etc.) to a user based on information received from the lighting system controller **300**. The capable display pattern(s) for each button may be stored in a look-up table residing in memory **206** (FIG. 1). Process block **654** uses the processor **204** and control logic/circuits **208** (FIG. 1) to identify the specific keypad button and display pattern in

the look-up table corresponding to the information received from the lighting system controller **300**.

Process block **656** comprises the remote control device **200** communicating the display information to the user (FIG. 4). In one embodiment, communicating comprises the remote control device **200** displaying the pattern on the identified keypad button in the user interface **210** of the remote control device **200** (FIG. 1) corresponding to the received information. In an alternative embodiment, communicating may comprise displaying words and/or images on a display screen located in the remote control device **200** (FIG. 1). Additionally communicating may comprise playing an audio file stored in memory **206** through a speaker located in the remote control device **200**.

FIG. 7A illustrates flowchart of a process **700** for controlling **510** (FIG. 5) at least one lighting system **400** (FIG. 1), according to an embodiment of the present invention. The process **700** may be implemented by the control logic **308** of a lighting controller system **300**, according to an embodiment of the invention.

Process block **702** comprises the lighting system controller **300** receiving input from a remote control device **200** (FIG. 1). In one embodiment, input from the remote control device **200** is received by the wireless transceiver **302** and interpreted using the control logic **308** and/or processor **304** in the lighting system controller **300** (FIG. 1).

Process block **704** comprises the lighting system controller **300** identifying a specific control function corresponding to the input received from the remote control device **200** (FIG. 1). In one embodiment, a lighting system **400** is capable of displaying certain patterns and/or sequences (e.g., flash, blink, strobe, solid color, pattern, audio activated, etc.), based on control signals received from a coupled lighting system controller **300**. In another embodiment, output jacks **318** and power jacks **326** in a lighting system controller **300** (FIG. 2) are capable of communicating operations and/or commands (e.g., turn on, turn off, enter standby mode, self-test, etc.) to lighting system(s) **400** connected thereto (FIG. 1).

In one example, while lighting systems **400** coupled to a power jack **326** may only be capable of on/off operations; lighting systems **400** coupled to an output jack **318** of the lighting system controller **300** (FIG. 3) may be capable of additional operations, for example, entering certain modes (e.g., standby, strobe, solid light, flicker, fade in/out, etc.). In one embodiment, the operation(s) for each output jack **318** and power jack **326** in a lighting system controller **300** are stored in a look-up table stored in memory **306** (FIG. 1).

Processor **304** of the lighting system controller **300** uses control logic/circuits **308** and the look-up table in memory **306** to identify (select) a specific jack (e.g., output jack **318** or power jack **326**) and display operation corresponding to the input received from the remote control device **200** (FIG. 1).

Process block **706** comprises the lighting system controller **300** communicating the identified display operation via the identified jack (output jack **318** or power jack **326**) to at least one lighting system **400** (FIG. 1) coupled thereto.

Additionally, the lighting system controller **300** is capable of receiving information from a user directly, wherein the user may initiate, for example, synchronizing/re-synchronizing communication between a remote control device **200** and the lighting system controller **300** (FIG. 1). FIG. 7B illustrates a flowchart of such a process **750** for controlling **510** (FIG. 5) at least one lighting system **400** (FIG. 1), according to an embodiment of the present invention. The user may initiate process block **752** by pressing the reset button **322** on the lighting system controller **300** thereby sending an input signal to the controller **300** (FIG. 2).

Process block 754 comprises the lighting system controller 300 identifying the display function to send to the remote control device 200 corresponding to the input received from the user at the lighting system controller 300 (FIG. 1). In one embodiment, display functions that can be sent to the remote control device 200 reside in a look-up table stored in memory 306 and may include, for example, that the indication LED 214 on the remote control device 200 (FIG. 4) illuminates or blinks during synchronization. Process block 754 uses the processor 304 and control logic/circuits 308 (FIG. 1) to identify the specific display function in the look-up table corresponding to the input received from the user at the lighting system controller 300.

Process block 756 comprises the lighting system controller 300 communicating the identified display function to the remote control device 200 (FIG. 2). In one embodiment, the wireless transceiver 302 of the lighting system controller 300 utilizes the antenna 310 to wirelessly communicate the identified display function to the remote control device 200 (FIG. 1) for display thereon.

As is known to those skilled in the art, the aforementioned example architectures described above, according to the present invention, can be implemented in many ways, such as program instructions for execution by a processor, as software modules, as microcode, as computer program products on computer readable media, as logic circuits, as application specific integrated circuits, as firmware, etc. Further, embodiments of the invention can take the form of an entirely hardware embodiment, an entirely software embodiment or an embodiment containing both hardware and software elements.

The present invention has been described in considerable detail with reference to certain preferred versions thereof; however, other versions are possible. Therefore, the spirit and scope of the appended claims should not be limited to the description of the preferred versions contained herein.

The terminology used herein is for the purpose of describing particular embodiments only and is not intended to be limiting of the invention. As used herein, the singular forms "a", "an" and "the" are intended to include the plural forms as well, unless the context clearly indicates otherwise. It will be further understood that the terms "comprises" and/or "comprising," when used in this specification, specify the presence of stated features, integers, steps, operations, elements, and/or components, but do not preclude the presence or addition of one or more other features, integers, steps, operations, elements, components, and/or groups thereof.

The corresponding structures, materials, acts, and equivalents of all means or step plus function elements in the claims below are intended to include any structure, material, or act for performing the function in combination with other claimed elements as specifically claimed. The description of the present invention has been presented for purposes of illustration and description, but is not intended to be exhaustive or limited to the invention in the form disclosed. Many modifications and variations will be apparent to those of ordinary skill in the art without departing from the scope and spirit of the invention. The embodiment was chosen and described in order to best explain the principles of the invention and the practical application, and to enable others of ordinary skill in the art to understand the invention for various embodiments with various modifications as are suited to the particular use contemplated.

What is claimed is:

1. A system, comprising:
one or more lighting systems, wherein each lighting system comprises one or more lighting modules; and

- a remote control device for selectively communicating operational information including one or more control signals to said lighting systems;
wherein a lighting function of a lighting system of said lighting systems is adjustable to one of a plurality of lighting functions based on said operational information.
2. The system of claim 1, wherein:
said remote control device comprises a communication module that facilitates wireless communication with said lighting systems via a wireless communication medium; and
said remote control device wirelessly communicates operational information to said lighting systems to wirelessly control said lighting systems.
3. The system of claim 1, wherein said remote control device is portable.
4. The system of claim 1, wherein:
each lighting system has a lighting controller for controlling a lighting function of said lighting system based on operational information from said remote control device; and
said remote control device is further configured to communicate control signals to, and receive control signals from, multiple lighting controllers.
5. The system of claim 2, wherein said remote control device further comprises:
a user interface for receiving one or more user commands for adjusting a lighting function of a lighting system of said lighting systems; and
a control logic for selectively communicating operational information to said lighting systems based on said one or more user commands.
6. The system of claim 5, wherein:
said user interface comprises a keypad for receiving one or more user commands for adjusting a lighting function of a lighting system of said lighting systems; and
said keypad includes one or more of the following: an all-on button, an all-off button, a standby button, a function button, a mode button, and a plurality of on/off buttons.
7. The system of claim 6, wherein, in response to a user activating said all-on button, said remote control device communicates a control signal for turning on each of said lighting systems.
8. The system of claim 6, wherein, in response to a user activating said all-off button, said remote control device communicates a control signal for turning off each of said lighting systems.
9. A system, comprising:
one or more lighting systems, wherein each lighting system includes one or more lighting modules; and
a remote control device for selectively communicating operational information including one or more control signals to said lighting systems;
wherein operation of said lighting systems is controlled based on said operational information;
wherein said remote control device comprises:
a communication module that facilitates wireless communication with said lighting systems via a wireless communication medium, such that said remote control device wirelessly communicates said operational information to said lighting systems to wirelessly control said lighting systems;
a user interface for receiving one or more user commands relating to operation of said lighting systems, wherein said user interface comprises a keypad for

11

receiving said one or more user commands, and said keypad includes one or more of the following: an all-on button, an all-off button, a standby button, a function button, a mode button, and a plurality of on/off buttons; and

a control logic for selectively communicating said operational information to said lighting systems based on said one or more user commands; and

wherein, in response to a user activating said standby button, said remote control device communicates a control signal for setting each of said lighting systems to a standby mode.

10. The system of claim 6, wherein, in response to a user activating said function button, said remote control device communicates a control signal for cycling through said plurality of lighting functions.

11. The system of claim 10, wherein said plurality of lighting functions includes at least one of the following: a standby lighting function, a sound activated lighting function, and an active lighting function.

12. The system of claim 6, wherein, in response to a user activating said mode button, said remote control device communicates a control signal for cycling through one or more lighting modes of at least one of said lighting systems.

13. The system of claim 12, wherein said one or more lighting modes includes at least one of the following: a solid lighting mode, a strobe lighting mode, and pattern lighting mode.

14. A system, comprising:
one or more lighting systems, wherein each lighting system includes one or more lighting modules; and
a remote control device for selectively communicating operational information including one or more control signals to said lighting systems;

wherein operation of said lighting systems is controlled based on said operational information;

wherein said remote control device comprises:

a communication module that facilitates wireless communication with said lighting systems via a wireless communication medium, such that said remote control device wirelessly communicates said operational information to said lighting systems to wirelessly control said lighting systems;

a user interface for receiving one or more user commands relating to operation of said lighting systems, wherein said user interface comprises a keypad for receiving said one or more user commands, and said keypad includes one or more of the following: an all-on button, an all-off button, a standby button, a function button, a mode button, and a plurality of on/off buttons; and

a control logic for selectively communicating said operational information to said lighting systems based on said one or more user commands;

wherein said plurality of on/off buttons includes an on/off button for each of said lighting systems; and

wherein, in response to a user activating an on/button for a particular one of said lighting systems, said remote control device communicates a control signal for turning on or turning off said particular lighting system.

15. The system of claim 1, wherein said remote control device individually controls operation of each of said lighting systems.

16. The system of claim 1, wherein said remote control device simultaneously controls operation of said lighting systems.

12

17. A method, comprising:

selectively communicating operational information including one or more control signals from a remote control device to one or more lighting systems, wherein each lighting system comprises one or more lighting modules; and

adjusting a lighting function of a lighting system of said lighting systems to one of a plurality of lighting functions based on said operational information.

18. The method of claim 17, comprising:

said remote control device wirelessly communicating, via a wireless communication medium, operational information to said lighting systems to wirelessly control said lighting systems.

19. The method of claim 17, comprising:

said remote control device receiving one or more user commands for adjusting a lighting function of a lighting system of said lighting systems; and
said remote control device selectively communicating operational information to said lighting systems based on said one or more user commands.

20. The method of claim 17, comprising:

said remote control device individually controlling a lighting function of a lighting system of said lighting systems.

21. The method of claim 17, comprising:

said remote control device simultaneously controlling a lighting function of each lighting system of said lighting systems.

22. A remote control device, comprising:

a user interface for receiving one or more user commands for adjusting a lighting function of one or more lighting systems, wherein each lighting system includes one or more lighting modules; and

a control logic for selectively communicating operational information to said lighting systems based on said one or more user commands, wherein a lighting function of a lighting system of said lighting systems is adjustable to one of a plurality of lighting functions based on said operational information.

23. The device of claim 22, further comprising:

a communication module for wirelessly communicating said operational information to said lighting systems; wherein said remote control device is further configured to:
individually control a lighting function of a lighting system of said lighting systems; and
simultaneously controls a lighting function of each lighting system of said lighting systems.

24. The device of claim 23, wherein:

said user interface comprises a keypad for receiving one or more user commands for adjusting a lighting function of a lighting system of said lighting systems; and
said keypad includes one or more of the following: an all-on button, an all-off button, a standby button, a function button, a mode button, and a plurality of on/off buttons.

25. The device of claim 24, wherein, in response to a user activating said all-on button, said remote control device communicates a control signal for turning on each of said lighting systems.

26. The device of claim 24, wherein, in response to a user activating said all-off button, said remote control device communicates a control signal for turning off each of said lighting systems.

27. A device, comprising:

one or more lighting systems, wherein each lighting system includes one or more lighting modules; and

13

a remote control device for selectively communicating operational information including one or more control signals to said lighting systems;
 wherein operation of said lighting systems is controlled based on said operational information; 5
 wherein said remote control device comprises:
 a communication module that facilitates wireless communication with said lighting systems via a wireless communication medium, such that said remote control device wirelessly communicates said operational information to said lighting systems to wirelessly control said lighting systems; 10
 a user interface for receiving one or more user commands relating to operation of said lighting systems, wherein said user interface comprises a keypad for receiving said one or more user commands, and said keypad includes one or more of the following: an all-on button, an all-off button, a standby button, a function button, a mode button, and a plurality of on/off buttons; and 20
 a control logic for selectively communicating said operational information to said lighting systems based on said one or more user commands; and
 wherein, in response to a user activating said standby button, said remote control device communicates a control signal for setting each of said lighting systems to a standby mode. 25

28. The device of claim **24**, wherein, in response to a user activating said function button, said remote control device communicates a control signal for cycling through said plurality of lighting functions. 30

29. The device of claim **24**, wherein, in response to a user activating said mode button, said remote control device communicates a control signal for cycling through one or more lighting modes of at least one of said lighting systems.

14

30. A device, comprising:
 one or more lighting systems, wherein each lighting system includes one or more lighting modules; and
 a remote control device for selectively communicating operational information including one or more control signals to said lighting systems;
 wherein operation of said lighting systems is controlled based on said operational information;
 wherein said remote control device comprises:
 a communication module that facilitates wireless communication with said lighting systems via a wireless communication medium, such that said remote control device wirelessly communicates said operational information to said lighting systems to wirelessly control said lighting systems;
 a user interface for receiving one or more user commands relating to operation of said lighting systems, wherein said user interface comprises a keypad for receiving said one or more user commands, and said keypad includes one or more of the following: an all-on button, an all-off button, a standby button, a function button, a mode button, and a plurality of on/off buttons; and
 a control logic for selectively communicating said operational information to said lighting systems based on said one or more user commands;
 wherein said plurality of on/off buttons includes an on/off button for each of said lighting systems; and
 wherein, in response to a user activating an on/button for a particular one of said lighting systems, said remote control device communicates a control signal for turning on or turning off said particular lighting system.

* * * * *