



US009271327B2

(12) **United States Patent**
Kish

(10) **Patent No.:** **US 9,271,327 B2**
(45) **Date of Patent:** **Feb. 23, 2016**

(54) **WIRELESS NETWORK THROUGHPUT ENHANCEMENT THROUGH CHANNEL AWARE SCHEDULING**

USPC 370/328, 331, 412; 455/436
See application file for complete search history.

(71) Applicant: **Ruckus Wireless, Inc.**, Sunnyvale, CA (US)

(56) **References Cited**

U.S. PATENT DOCUMENTS

(72) Inventor: **William S. Kish**, Saratoga, CA (US)

1,653,664 A 12/1927 Kirkup
4,176,356 A 11/1979 Foster et al.
4,193,077 A 3/1980 Greenberg et al.
4,253,193 A 2/1981 Kennard

(73) Assignee: **RUCKUS WIRELESS, INC.**, Sunnyvale, CA (US)

(Continued)

(*) Notice: Subject to any disclaimer, the term of this patent is extended or adjusted under 35 U.S.C. 154(b) by 0 days.

FOREIGN PATENT DOCUMENTS

(21) Appl. No.: **14/028,323**

CN 1 965 598 5/2007
CN 102763378 10/2012

(22) Filed: **Sep. 16, 2013**

(Continued)

(65) **Prior Publication Data**

US 2014/0016563 A1 Jan. 16, 2014

OTHER PUBLICATIONS

Chinese Application No. 20058001629.7, Office Action dated Jan. 21, 2014.

(Continued)

Related U.S. Application Data

(63) Continuation of application No. 12/181,274, filed on Jul. 28, 2008, now Pat. No. 8,547,899.

Primary Examiner — Pao Sinkantarakorn

Assistant Examiner — Richard Chang

(60) Provisional application No. 60/952,557, filed on Jul. 28, 2007.

(74) *Attorney, Agent, or Firm* — Lewis Roca Rothgerber Christie LLP

(51) **Int. Cl.**
H04W 80/04 (2009.01)
H04W 72/12 (2009.01)
H04W 88/06 (2009.01)

(57) **ABSTRACT**

A channel aware scheduler (CAS) is disclosed that takes advantage of changing wireless channel conditions in order to maximize aggregated system throughput. The CAS is aware of the different channel conditions for one or more stations and adjusts its scheduling of packet transmissions in light of the same. A related CAS algorithm may take advantage of that knowledge in order to increase aggregated system throughput while concurrently addressing other potential fairness constraints.

(52) **U.S. Cl.**
CPC **H04W 80/04** (2013.01); **H04W 72/1242** (2013.01); **H04W 88/06** (2013.01); **H04W 72/1257** (2013.01)

(58) **Field of Classification Search**
CPC . H04W 72/1242; H04W 80/04; H04W 88/06; H04W 72/1257

17 Claims, 7 Drawing Sheets

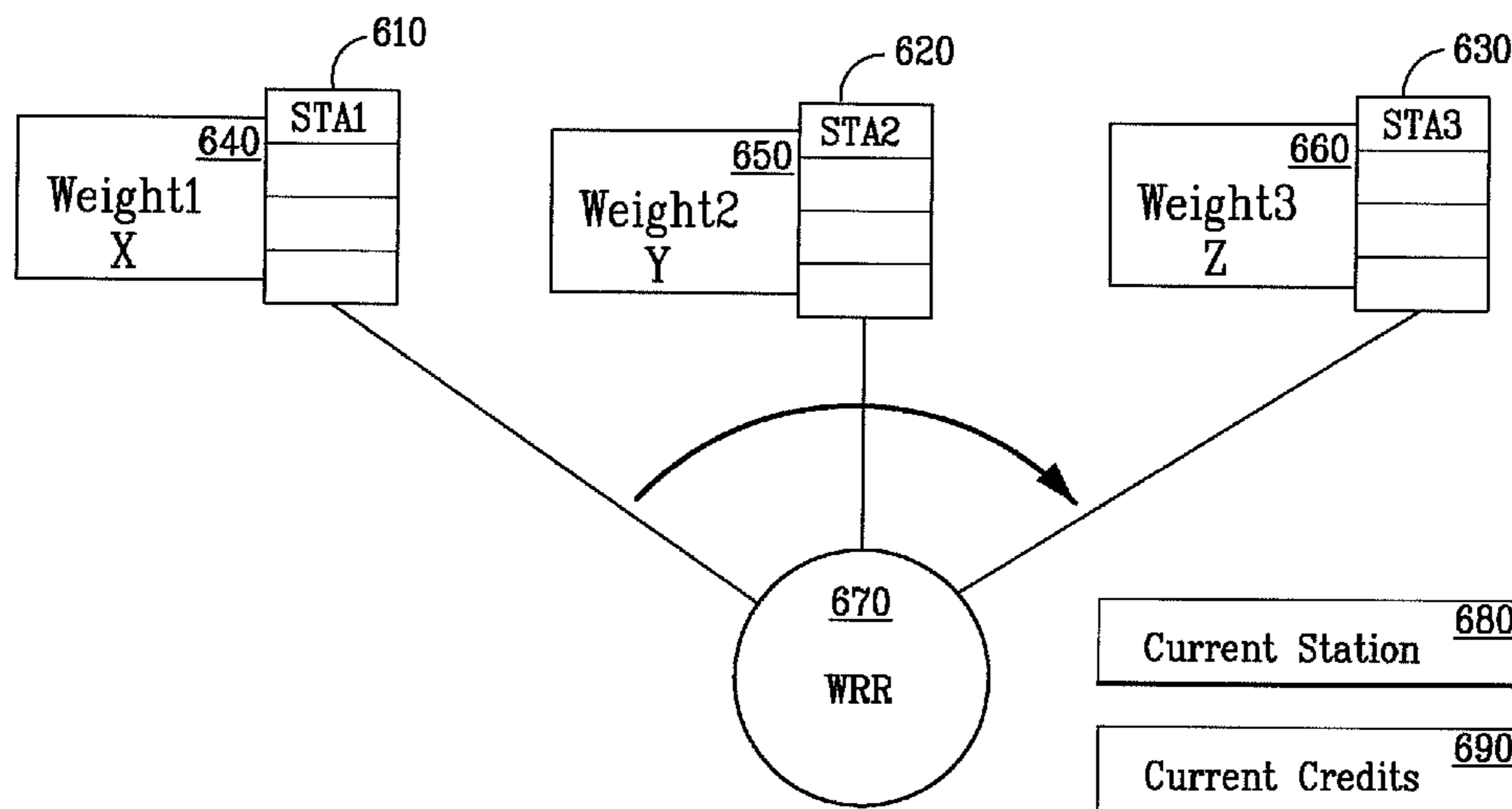

(56)

References Cited

U.S. PATENT DOCUMENTS

4,305,052 A	12/1981	Baril et al.	6,778,517 B1	8/2004	Lou et al.
4,513,412 A	4/1985	Cox	6,779,004 B1	8/2004	Zintel
4,814,777 A	3/1989	Monser	6,819,287 B2	11/2004	Sullivan et al.
5,097,484 A	3/1992	Akaiwa	6,836,481 B1	12/2004	Hotta
5,117,430 A	5/1992	Berglund	6,873,627 B1	3/2005	Miller
5,173,711 A	12/1992	Takeuchi et al.	6,876,280 B2	4/2005	Nakano
5,203,010 A	4/1993	Felix	6,888,504 B2	5/2005	Chiang et al.
5,220,340 A	6/1993	Shafai	6,888,893 B2	5/2005	Li et al.
5,220,678 A	6/1993	Feei	6,892,230 B1	5/2005	Gu et al.
5,361,256 A	11/1994	Doeringer	6,906,678 B2	6/2005	Chen
5,373,548 A	12/1994	McCarthy	6,910,068 B2	6/2005	Zintel et al.
5,408,465 A	4/1995	Gusella et al.	6,924,768 B2	8/2005	Wu et al.
5,507,035 A	4/1996	Bantz	6,931,429 B2	8/2005	Gouge et al.
5,559,800 A	9/1996	Mousseau et al.	6,941,143 B2	9/2005	Mathur
5,570,366 A	10/1996	Baker	6,950,019 B2	9/2005	Bellone et al.
5,608,726 A	3/1997	Virgile	6,957,042 B2	10/2005	Williams
5,636,213 A	6/1997	Eastmond et al.	6,957,277 B2	10/2005	Yagyu et al.
5,754,145 A	5/1998	Evans	6,961,028 B2	11/2005	Joy et al.
5,767,809 A	6/1998	Chuang et al.	6,973,622 B1	12/2005	Rappaport et al.
5,802,312 A	9/1998	Lazaridis et al.	6,975,834 B1	12/2005	Forster
5,867,109 A	2/1999	Wiedeman	6,996,086 B2	2/2006	Wolfe et al.
5,930,259 A	7/1999	Katsube	7,034,770 B2	4/2006	Yang et al.
5,940,771 A	8/1999	Gollnick et al.	7,043,277 B1	5/2006	Pfister
5,960,344 A	9/1999	Mahany	7,050,809 B2	5/2006	Lim
5,964,830 A	10/1999	Durrett	7,053,853 B2	5/2006	Merenda et al.
5,970,410 A	10/1999	Carney et al.	7,064,717 B2	6/2006	Kaluzni et al.
5,974,034 A	10/1999	Chin et al.	7,076,274 B2	7/2006	Jollota et al.
6,018,659 A	1/2000	Ayyagari et al.	7,085,814 B1	8/2006	Ghandhi et al.
6,034,638 A	3/2000	Thiel et al.	7,089,307 B2	8/2006	Zintel et al.
6,044,062 A	3/2000	Brownrigg et al.	7,113,519 B2	9/2006	Hammel et al.
6,088,570 A	7/2000	Komara et al.	7,130,895 B2	10/2006	Zintel et al.
6,094,177 A	7/2000	Yamamoto	7,136,655 B2	11/2006	Skafidas et al.
6,132,306 A	10/2000	Trompower	7,149,197 B2	12/2006	Garahi et al.
6,181,697 B1	1/2001	Nurenberg	7,157,757 B2	1/2007	Parekh et al.
6,249,516 B1	6/2001	Brownrigg et al.	7,161,934 B2	1/2007	Buchsbaum
6,266,528 B1	7/2001	Farzaneh	7,164,667 B2	1/2007	Rayment et al.
6,266,537 B1	7/2001	Kashitani et al.	7,171,223 B2	1/2007	Herscovich et al.
6,292,153 B1	9/2001	Aiello et al.	7,171,475 B2	1/2007	Weisman et al.
6,307,524 B1	10/2001	Britain	7,187,925 B2	3/2007	Abhishek
6,317,599 B1	11/2001	Rappaport et al.	7,203,508 B2	4/2007	Ohkubo et al.
6,326,922 B1	12/2001	Hegendoerfer	7,269,174 B2	9/2007	Olson et al.
6,337,628 B2	1/2002	Campana et al.	7,283,494 B2	10/2007	Hammel et al.
6,337,668 B1	1/2002	Ito et al.	7,289,505 B2	10/2007	Sanchez
6,339,404 B1	1/2002	Johnson et al.	7,292,617 B2	11/2007	Beasley et al.
6,345,043 B1	2/2002	Hsu	7,321,571 B2	1/2008	Schnack et al.
6,356,242 B1	3/2002	Ploussios	7,336,642 B2	2/2008	Rich et al.
6,356,243 B1	3/2002	Schneider et al.	7,355,997 B2	4/2008	Qian
6,356,553 B1	3/2002	Nagami et al.	7,362,737 B2	4/2008	Behroozi
6,356,905 B1	3/2002	Gershman et al.	7,369,510 B1	5/2008	Wong
6,377,227 B1	4/2002	Zhu et al.	7,489,932 B2	2/2009	Chari et al.
6,392,610 B1	5/2002	Braun et al.	7,496,680 B2	2/2009	Canright
6,393,261 B1	5/2002	Lewis	7,505,426 B2	3/2009	Srikrishna et al.
6,404,386 B1	6/2002	Proctor, Jr. et al.	7,505,447 B2	3/2009	Kish et al.
6,404,775 B1	6/2002	Leslie et al.	7,515,589 B2	4/2009	Bacher et al.
6,407,719 B1	6/2002	Ohira et al.	7,522,731 B2	4/2009	Kiemba et al.
6,414,955 B1	7/2002	Clare et al.	7,546,126 B2	6/2009	Beasley et al.
6,418,138 B1	7/2002	Cerf et al.	7,551,562 B2	6/2009	Srikrishna et al.
6,442,507 B1	8/2002	Skidmore et al.	7,586,879 B2	9/2009	Chari et al.
6,445,688 B1	9/2002	Garces et al.	7,672,274 B2	3/2010	Bims
6,493,679 B1	12/2002	Rappaport et al.	7,697,504 B2	4/2010	Chari et al.
6,498,589 B1	12/2002	Horii	7,715,395 B2	5/2010	Ginchereau et al.
6,499,006 B1	12/2002	Rappaport et al.	7,733,833 B2	6/2010	Kalika et al.
6,505,253 B1	1/2003	Chiu	7,787,436 B2	8/2010	Kish et al.
6,507,321 B2	1/2003	Oberschmidt et al.	7,853,829 B2	12/2010	Younger et al.
6,570,883 B1 *	5/2003	Wong 370/412	7,916,684 B2	3/2011	Henderson et al.
6,584,080 B1	6/2003	Ganz et al.	7,974,223 B2	7/2011	Zellig et al.
6,625,454 B1	9/2003	Rappaport et al.	8,089,869 B2	1/2012	Kisela et al.
6,674,459 B2	1/2004	Ben-Shachar et al.	8,089,949 B2	1/2012	Kish et al.
6,701,522 B1	3/2004	Rubin et al.	8,125,975 B2	2/2012	Kish et al.
6,704,301 B2	3/2004	Chari et al.	8,355,343 B2	1/2013	Kish et al.
6,714,551 B1	3/2004	Le-Ngoc	8,547,899 B2	10/2013	Kish
6,725,281 B1	4/2004	Zintel et al.	8,619,662 B2	12/2013	Kish
6,728,514 B2	4/2004	Bandeira et al.	8,634,402 B2	1/2014	Kish
6,753,814 B2	6/2004	Killen et al.	8,638,708 B2	1/2014	Kish
6,762,723 B2	7/2004	Nallo et al.	8,688,834 B2	4/2014	Fujimoto et al.
			8,780,760 B2	7/2014	Kish
			8,824,357 B2	9/2014	Kish et al.
			9,066,152 B2	6/2015	Kish
			9,071,942 B2	6/2015	Kish

(56)

References Cited

U.S. PATENT DOCUMENTS

2001/0047474	A1	11/2001	Takagi et al.	2005/0226239	A1	10/2005	Nishida et al.
2001/0055312	A1	12/2001	Negus	2005/0232179	A1	10/2005	Da Costa et al.
2002/0001310	A1	1/2002	Mai	2005/0240665	A1	10/2005	Gu et al.
2002/0031130	A1	3/2002	Tsuchiya et al.	2005/0250544	A1	11/2005	Grant et al.
2002/0036996	A1	3/2002	Ozluturk et al.	2005/0267935	A1	12/2005	Ghandhi et al.
2002/0045435	A1	4/2002	Fantaske	2005/0271070	A1	12/2005	Mikami et al.
2002/0047800	A1	4/2002	Proctor, Jr. et al.	2006/0018335	A1	1/2006	Koch
2002/0080767	A1	6/2002	Lee	2006/0045089	A1	3/2006	Bacher et al.
2002/0084942	A1	7/2002	Tsai et al.	2006/0094371	A1	5/2006	Nguyen
2002/0105471	A1	8/2002	Kojima et al.	2006/0098605	A1	5/2006	Li
2002/0112058	A1	8/2002	Weisman et al.	2006/0098607	A1	5/2006	Zeng et al.
2002/0114330	A1	8/2002	Cheung et al.	2006/0098613	A1	5/2006	Kish et al.
2002/0143951	A1	10/2002	Khan	2006/0098616	A1	5/2006	Kish et al.
2002/0158798	A1	10/2002	Chiang et al.	2006/0114881	A1	6/2006	Chari
2002/0158801	A1	10/2002	Crilly, Jr. et al.	2006/0123124	A1	6/2006	Weisman et al.
2002/0164963	A1	11/2002	Tehrani et al.	2006/0123125	A1	6/2006	Weisman et al.
2002/0170064	A1	11/2002	Monroe et al.	2006/0123455	A1	6/2006	Pai et al.
2002/0194367	A1	12/2002	Nakamura et al.	2006/0133341	A1	6/2006	Chari et al.
2003/0003917	A1	1/2003	Copley et al.	2006/0165029	A1	7/2006	Melpignano et al.
2003/0026240	A1	2/2003	Eyuboglu et al.	2006/0168159	A1	7/2006	Weisman et al.
2003/0026268	A1	2/2003	Nava	2006/0184660	A1	8/2006	Rao et al.
2003/0030588	A1	2/2003	Kalis et al.	2006/0184661	A1	8/2006	Weisman et al.
2003/0043786	A1	3/2003	Kall	2006/0184693	A1	8/2006	Rao et al.
2003/0063591	A1	4/2003	Leung et al.	2006/0224690	A1	10/2006	Falkenburg et al.
2003/0122714	A1	7/2003	Wannagot et al.	2006/0225107	A1	10/2006	Seetharaman et al.
2003/0133458	A1	7/2003	Sato et al.	2006/0227761	A1	10/2006	Scott, III et al.
2003/0169330	A1	9/2003	Ben-Shachar et al.	2006/0239369	A1	10/2006	Lee
2003/0184490	A1	10/2003	Raiman et al.	2006/0268881	A1	11/2006	Moreton
2003/0189514	A1	10/2003	Miyano et al.	2006/0280131	A1	12/2006	Rahman et al.
2003/0189521	A1	10/2003	Yamamoto et al.	2006/0291434	A1	12/2006	Gu et al.
2003/0189523	A1	10/2003	Ojantakanen et al.	2007/0002750	A1*	1/2007	Sang et al. 370/238
2003/0210207	A1	11/2003	Suh et al.	2007/0010271	A1	1/2007	Roy
2003/0227414	A1	12/2003	Saliga et al.	2007/0027622	A1	2/2007	Cleron et al.
2003/0228857	A1	12/2003	Maeki	2007/0030811	A1	2/2007	Frei et al.
2003/0231593	A1	12/2003	Bauman et al.	2007/0072612	A1*	3/2007	Haraguchi et al. 455/436
2004/0008663	A1	1/2004	Srikrishna	2007/0101020	A1	5/2007	Lin et al.
2004/0014432	A1	1/2004	Boyle	2007/0109961	A1	5/2007	Liang
2004/0017310	A1	1/2004	Vargas-Hurlston et al.	2007/0135167	A1	6/2007	Liu
2004/0017860	A1	1/2004	Liu	2007/0189283	A1	8/2007	Agarwal et al.
2004/0027291	A1	2/2004	Zhang et al.	2007/0223451	A1	9/2007	Ren et al.
2004/0027304	A1	2/2004	Chiang et al.	2007/0242602	A1	10/2007	Pang et al.
2004/0028006	A1	2/2004	Kayama	2007/0280168	A1*	12/2007	Shibata 370/331
2004/0032378	A1	2/2004	Volman et al.	2008/0043638	A1	2/2008	Ribiere
2004/0036651	A1	2/2004	Toda	2008/0069068	A1	3/2008	Dean et al.
2004/0036654	A1	2/2004	Hsieh	2008/0137681	A1	6/2008	Kish et al.
2004/0041732	A1	3/2004	Aikawa et al.	2008/0137682	A1	6/2008	Kish et al.
2004/0048593	A1	3/2004	Sano	2008/0159207	A1	7/2008	Levine et al.
2004/0058690	A1	3/2004	Ratzel et al.	2008/0225804	A1	9/2008	Thubert
2004/0061653	A1	4/2004	Webb et al.	2008/0247317	A1	10/2008	Weil et al.
2004/0070543	A1	4/2004	Masaki	2008/0247327	A1	10/2008	Weil et al.
2004/0080455	A1	4/2004	Lee	2008/0267116	A1	10/2008	Kang et al.
2004/0085993	A1	5/2004	Wentink	2009/0019314	A1	1/2009	Younger et al.
2004/0095278	A1	5/2004	Kanemoto et al.	2009/0028095	A1	1/2009	Kish et al.
2004/0114535	A1	6/2004	Hoffman et al.	2009/0040989	A1	2/2009	Da Costa et al.
2004/0125777	A1	7/2004	Doyle et al.	2009/0067369	A1	3/2009	Stamoulis
2004/0190477	A1	9/2004	Olson et al.	2009/0073921	A1	3/2009	Ji et al.
2004/0260800	A1	12/2004	Gu et al.	2009/0080333	A1	3/2009	Ozer et al.
2004/0264463	A1	12/2004	Fukushima	2009/0154359	A1	6/2009	Strutt et al.
2005/0002395	A1	1/2005	Kondo	2009/0180396	A1	7/2009	Kish et al.
2005/0009523	A1	1/2005	Pekonen	2009/0207730	A1	8/2009	Stamoulis et al.
2005/0022210	A1	1/2005	Zintel et al.	2009/0213730	A1	8/2009	Zeng et al.
2005/0032531	A1	2/2005	Gong et al.	2009/0225676	A1	9/2009	Kisela et al.
2005/0041739	A1	2/2005	Li et al.	2009/0262677	A1	10/2009	Banerjea et al.
2005/0042988	A1	2/2005	Hoek et al.	2010/0040056	A1	2/2010	Kobayashi
2005/0074018	A1	4/2005	Zintel et al.	2010/0085916	A1	4/2010	Yu et al.
2005/0074019	A1	4/2005	Handforth et al.	2010/0182944	A1	7/2010	Kish et al.
2005/0074108	A1	4/2005	Dezonno et al.	2011/0096712	A1	4/2011	Kish et al.
2005/0097503	A1	5/2005	Zintel et al.	2011/0119360	A1	5/2011	Miu et al.
2005/0135480	A1	6/2005	Li et al.	2011/0119401	A1	5/2011	Miu et al.
2005/0138137	A1	6/2005	Encarnacion et al.	2011/0158233	A1	6/2011	Namgung
2005/0138193	A1	6/2005	Encarnacion et al.	2011/0216685	A1	9/2011	Kish et al.
2005/0153720	A1	7/2005	White et al.	2012/0063379	A1	3/2012	Kish et al.
2005/0180381	A1	8/2005	Retzer et al.	2013/0010775	A1	1/2013	Kish et al.
2005/0185666	A1	8/2005	Raya	2013/0194969	A1	8/2013	Kish
2005/0188193	A1	8/2005	Kuehnel et al.	2014/0071879	A1	3/2014	Kish

(56)

References Cited

U.S. PATENT DOCUMENTS

2014/0133385 A1 5/2014 Kish
 2014/0177511 A1 6/2014 Kish
 2015/0312727 A1 10/2015 Kish

FOREIGN PATENT DOCUMENTS

EP	0 352 787	7/1989
EP	0 534 612	3/1993
EP	1 315 311	5/2003
EP	1 450 521	8/2004
EP	1 608 108	12/2005
EP	1 653 664	5/2006
EP	2 350 863	8/2015
GB	2306278	4/1997
JP	2001-057560	2/2001
JP	2003-038933	2/2003
JP	2005-354249	12/2005
JP	2006-060408	3/2006
JP	2008-088633	4/2008
VN	31159	10/2012
WO	WO 02/25967	3/2002
WO	WO 02/49360	6/2002
WO	WO 03/079484	9/2003
WO	WO 2004/057817	7/2004
WO	WO 2005/008938	1/2005
WO	WO 2006/052639	5/2006
WO	WO 2007/016326	2/2007
WO	WO 2009/088488	7/2009
WO	WO 2011/060454	5/2011
WO	WO 2012/061531	5/2012

OTHER PUBLICATIONS

U.S. Appl. No. 14/080,488, William S.Kish, Mac Based Mapping in IP Based Communications, Nov. 14, 2013.
 U.S. Appl. No. 14/106,514, William S.Kish, Unicast to Multicast Conversion, Dec. 13, 2013.
 U.S. Appl. No. 14/160,402 Office Action mailed Oct. 22, 2014.
 U.S. Appl. No. 14/080,488, Office Action mailed Oct. 21, 2014.
 U.S. Appl. No. 11/267,477, Decision on Appeal mailed Nov. 14, 2014.
 Chinese Application No. 201080002467.X, Second Office Action dated Jan. 26, 2015.
 Chinese Application No. 201080002467.X, Office Action dated Jul. 3, 2014.
 Chinese Application No. 20058001629.7, Office Action dated Aug. 6, 2014.
 U.S. Appl. No. 14/106,514, Office Action mailed Sep. 22, 2014.
 U.S. Appl. No. 14/748,141, William S. Kish, Distributed Access Point for IP Based Communications, Jun. 23, 2015.
 Akyildiz et al., "Wireless mesh networks: a survey," *Computer Networks*, 2005.
 Areg Alimian et al., "Analysis of Roaming Techniques," doc.:IEEE 802.11-04/0377r1, Submission, Mar. 2004.
 Cato et al., "Method for Easier, Better, and Faster Site Surveys for Wireless Networks," *IBM Technical Disclosure Bulletin*, vol. 40, No. 1, 1997.
 Chang, Nicholas B. et al., "Optimal Channel Probing and Transmission Scheduling for Opportunistic Spectrum Access," Sep. 2007.
 Chawla, "Design of a Wireless Backhaul Network for Microcells," 1999.
 Cisco Systems, "Cisco Aironet Access Point Software Configuration Guide: Configuring Filters and Quality of Service," Aug. 2003.
 Dell Inc., "How Much Broadcast and Multicast Traffic Should I Allow in My Network," *PowerConnect Application Note #5*, Nov. 2003.
 Dunkels, Adam et al., "Connecting Wireless Sensornets with TCP/IP Networks," *Proc. of the 2d Int'l Conf. on Wired Networks*, Frankfurt, Feb. 2004.
 Dunkels, Adam et al., "Making TCP/IP Viable for Wireless Sensor Networks," *Proc. of the 1st Euro. Workshop on Wireless Sensor Networks*, Berlin, Jan. 2004.

Dutta, Ashutosh et al., "MarconiNet Supporting Streaming Media Over Localized Wireless Multicast," *Proc. of the 2d Int'l Workshop on Mobile Commerce*, 2002.

Fair queuing, http://en.wikipedia.org/wiki/fair_queuing. Aug. 11, 2008.

Festag, Andreas, "What is MOMBASA?" *Telecommunication Networks Group (TKN)*, Technical University of Berlin, Mar. 7, 2002.

Gillham, Burce et al. *JUNOSe Internet Software for E-Series Routing Platforms Policy and QoS Configuration Guide*, Release 7.0x, Sep. 7, 2005.

Golmie, Nada, "Coexistence in Wireless Networks: Challenges and System-Level Solutions in the Unlicensed Bands," *Cambridge University Press*, 2006.

Hewlett Packard, "HP ProCurve Networking: Enterprise Wireless LAN Networking and Mobility Solutions," 2003.

Hirayama, Koji et al., "Next-Generation Mobile-Access IP Network," *Hitachi Review* vol. 49, No. 4, 2000.

Hjalmtysson et al., *Overcoming Last-Hop/First-Hop Problems in IP Multicast*, Reykjavik University, Dept. of Computer Science, Ofanleiti 2, 103 Reykjavik, Iceland, (The Icelandic Center for Research under grant No. 020500002.). Sep. 16-19, 2003.

Ian R. Akyildiz, et al., "A Virtual Topology Based Routing Protocol for Multihop Dynamic Wireless Networks," *Broadband and Wireless Networking Lab, School of Electrical and Computer Engineering, Georgia Institute of Technology*, Jul. 1, 2001.

Information Society Technologies Ultrawaves, "System Concept / Architecture Design and Communication Stack Requirement Document," Feb. 23, 2004.

Johansson et al., "Relaying Access Points and Related Business Models for Low Cost Mobile Systems," 2004.

Ken Tang, et al., "MAC Layer Broadcast Support in 802.11 Wireless Networks," *Computer Science Department, University of California, Los Angeles*, 2000 IEEE, pp. 544-548.

Ken Tang, et al., "MAC Reliable Broadcast in Ad Hoc Networks," *Computer Science Department, University of California, Los Angeles*, 2001 IEEE, pp. 1008-1013.

Mawa, Rakesh, "Power Control in 3G Systems," *Hughes Systique Corporation*, Jun. 28, 2006.

Microsoft Corporation, "IEEE 802.11 Networks and Windows XP," *Windows Hardware Developer Central*, Dec. 4, 2001.

Pat Calhoun et al., "802.11r strengthens wireless voice," *Technology Update, Network World*, Aug. 22, 2005, <http://www.networkworld.com/news/tech/2005/082208techupdate.html>.

Steger, Christopher et al., "Performance of IEEE 802.11b Wireless LAN in an Emulated Mobile Channel," 2003.

Toskala, Antti, "Enhancement of Broadcast and Introduction of Multicast Capabilities in RAN," *Nokia Networks, Palm Springs, California*, Mar. 13-16, 2001.

Tsunekawa, Kouichi "Diversity Antennas for Portable Telephones," *39th IEEE Vehicular Technology*, May 1-3, 1989, San Francisco, CA.

Vincent D. Park, et al., "A Performance Comparison of the Temporally-Ordered Routing Algorithm and Ideal Link-State Routing," *IEEE*, Jul. 1998, pp. 592-598.

Visoottiviseth et al., *Sender-Initiated Multicast Forwarding Scheme*, *Telecommunications*, 2003, *ICT 2003 10th International Conference*, pp. 334-339, downloaded on Mar. 26, 2009 from IEEE Xplore, 0-7803-7661 (c) 2003 IEEE.

Weighted Fair Queuing, http://en.wikipedia.org/wiki/Weighted_fair_queuing. Aug. 11, 2008.

Weighted Round Robin, http://en.wikipedia.org/wiki/Weighted_round_robin Aug. 8, 2008.

Wennstrom, Mattias et al., "Transmit Antenna Diversity in Ricean Fading MIMO Channels with Co-Channel Interference," 2001.

Yanikomeroğlu, "Cellular Multihop Communications: Infrastructure-Based Relay Network Architecture for 4G Wireless Systems," 2004.

PCT Search Report and Written Opinion for PCT/US08/014148 mailed Mar. 30, 2009.

PCT Search Report and Written Opinion for PCT/US11/059019 mailed Feb. 21, 2012.

PCT Search Report and Written Opinion for PCT/US05/039760 mailed Sep. 14, 2006.

(56)

References Cited

OTHER PUBLICATIONS

PCT Search Report and Written Opinion for PCT/US10/56908 mailed May 3, 2011.
CN Application No. 20058001629.7, Office Action dated Feb. 21, 2012.
EP Application No. 10813061.8. Supplementary European Search Report dated Jul. 23, 2012.
EP Application No. 10813061.8. Extended European Search Report dated Oct. 21, 2011.
TW Application No. 094138837, Office Action dated Apr. 25, 2013.
TW Application No. 094138837, Office Action dated Nov. 28, 2011.
U.S. Appl. No. 12/008,715, Office Action mailed Sep. 2, 2011.
U.S. Appl. No. 12/008,715, Final Office Action mailed Nov. 23, 2010.
U.S. Appl. No. 12/008,715, Office Action mailed Jun. 7, 2010.
U.S. Appl. No. 12/008,715, Office Action mailed Oct. 16, 2009.
U.S. Appl. No. 13/736,017 Office Action mailed Nov. 21, 2013.
U.S. Appl. No. 11/232,196, Office Action mailed May 15, 2008.
U.S. Appl. No. 11/232,196, Final Office Action mailed Dec. 26, 2007.

U.S. Appl. No. 11/232,196, Office Action mailed Apr. 5, 2007.
U.S. Appl. No. 11/985,865, Office Action mailed Dec. 20, 2010.
U.S. Appl. No. 11/985,866, Office Action mailed Dec. 16, 2009.
U.S. Appl. No. 11/985,866, Office Action mailed May 29, 2009.
U.S. Appl. No. 11/267,477, Final Office Action mailed Oct. 6, 2010.
U.S. Appl. No. 11/267,477, Office Action mailed Jun. 16, 2010.
U.S. Appl. No. 11/267,477, Final Office Action mailed Jun. 10, 2009.
U.S. Appl. No. 11/267,477, Office Action mailed Sep. 25, 2008.
U.S. Appl. No. 12/181,274, Final Office Action mailed Jun. 19, 2013.
U.S. Appl. No. 12/181,274, Office Action mailed Nov. 15, 2012.
U.S. Appl. No. 12/181,274, Final Office Action mailed Jan. 18, 2012.
U.S. Appl. No. 12/181,274, Office Action mailed Jun. 10, 2011.
U.S. Appl. No. 12/947,800, Final Office Action mailed Jul. 17, 2013.
U.S. Appl. No. 12/947,800, Office Action mailed Sep. 26, 2012.
U.S. Appl. No. 12/947,803, Final Office Action mailed Jul. 17, 2013.
U.S. Appl. No. 12/947,803, Office Action mailed Aug. 27, 2012.
U.S. Appl. No. 12/938,316, Office Action mailed Nov. 20, 2012.
Taiwan Application No. 103106913, Office Action dated May 28, 2015.

* cited by examiner

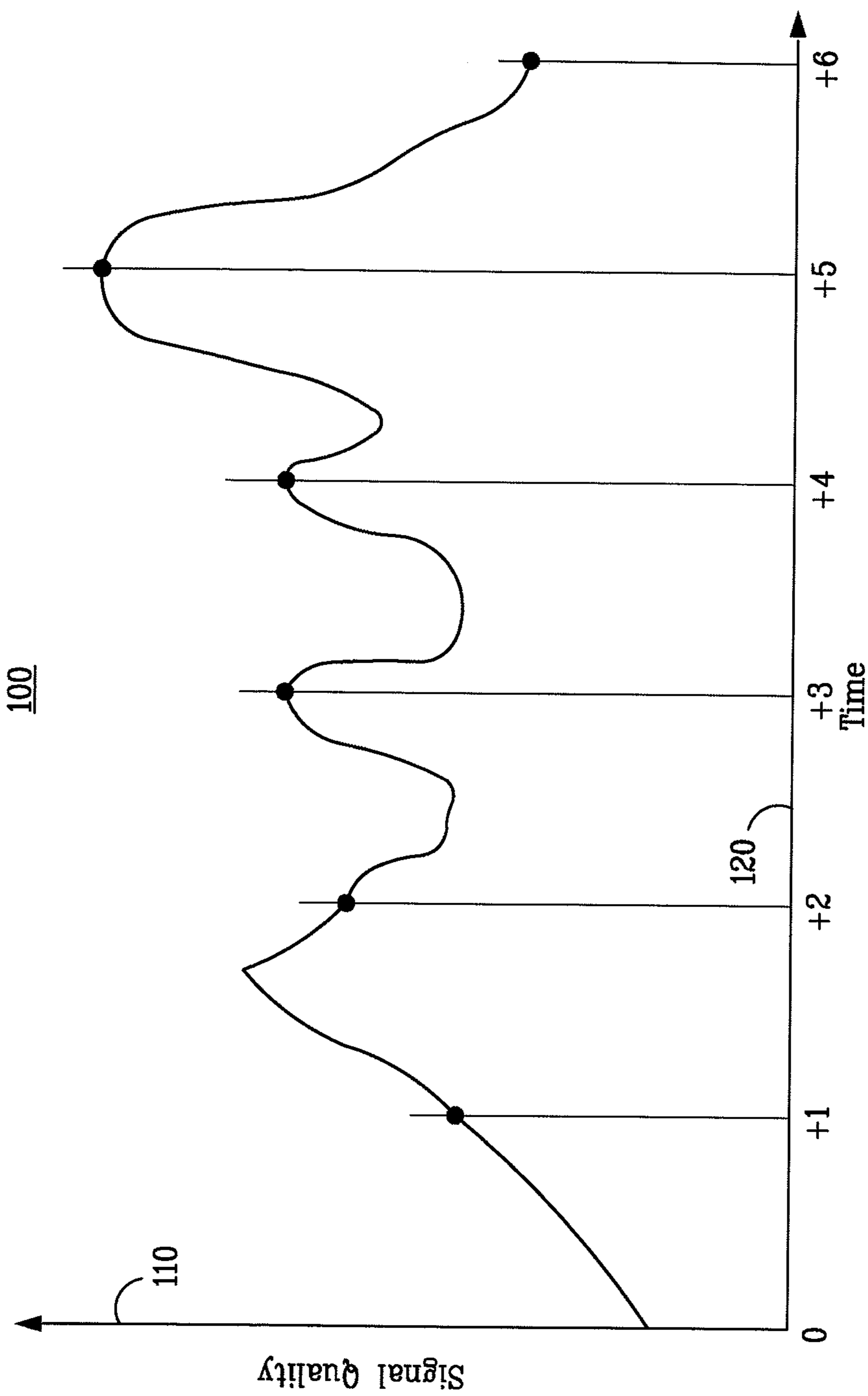

Prior Art
FIG. 1A

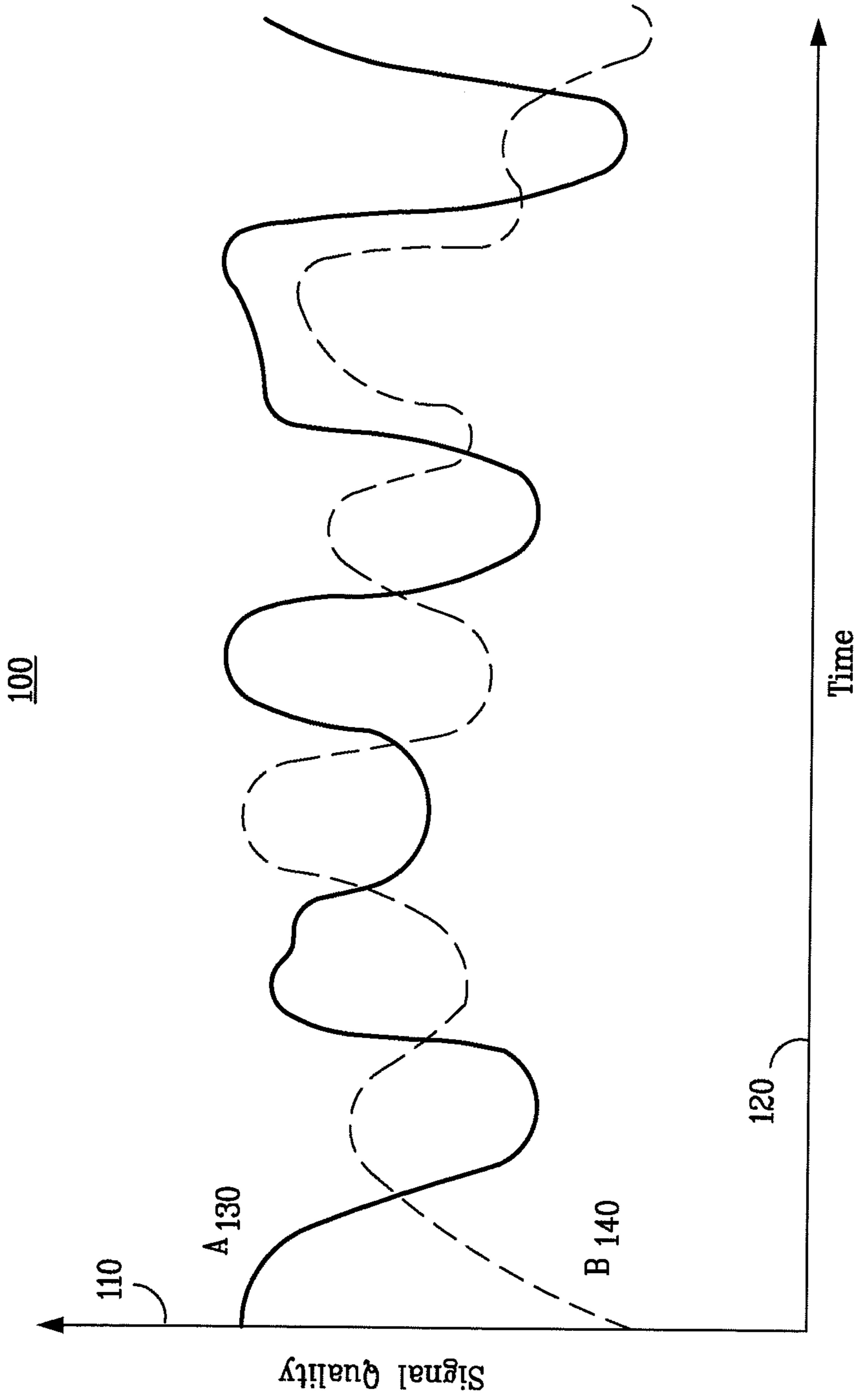

Prior Art
FIG. 1B

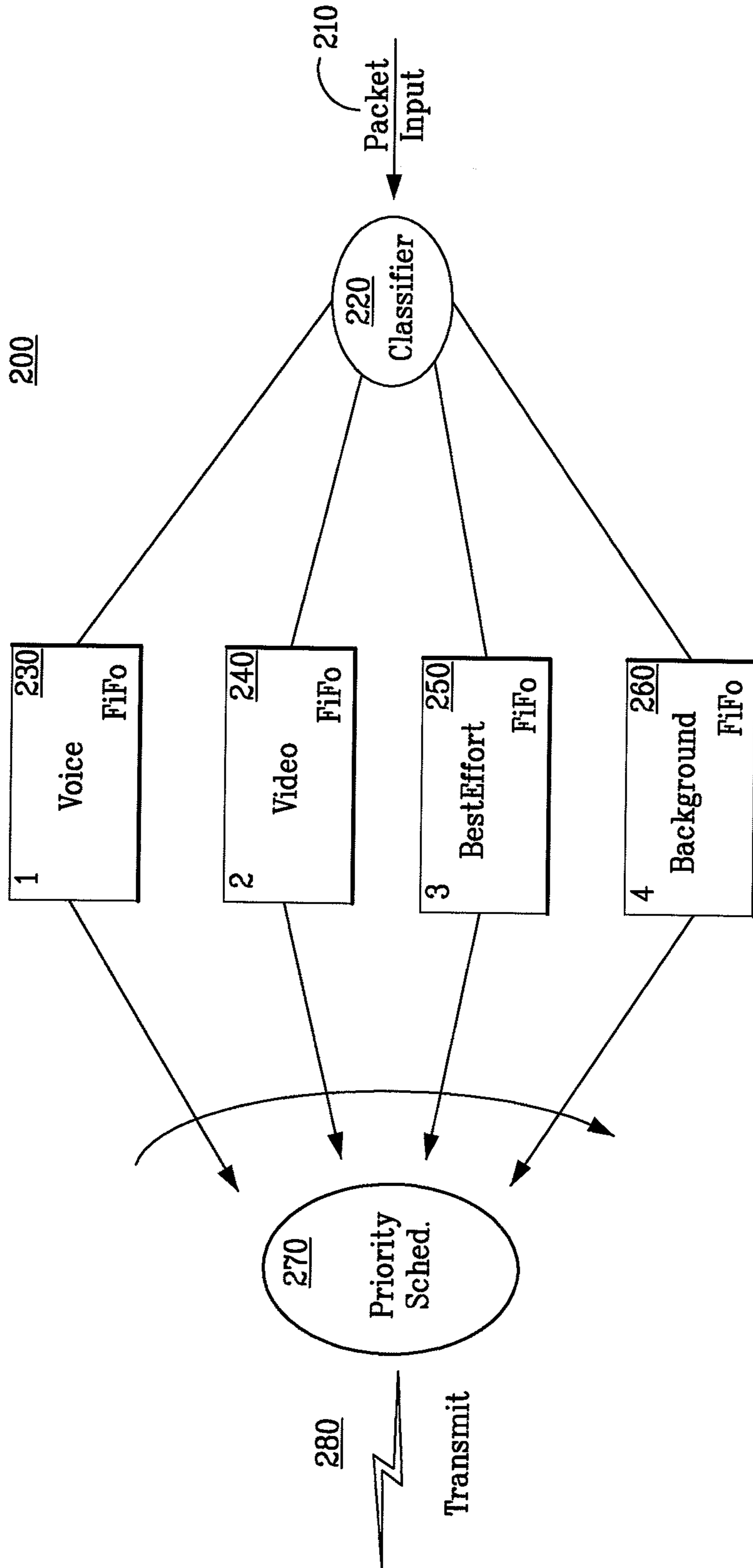

Prior Art
FIG. 2

300

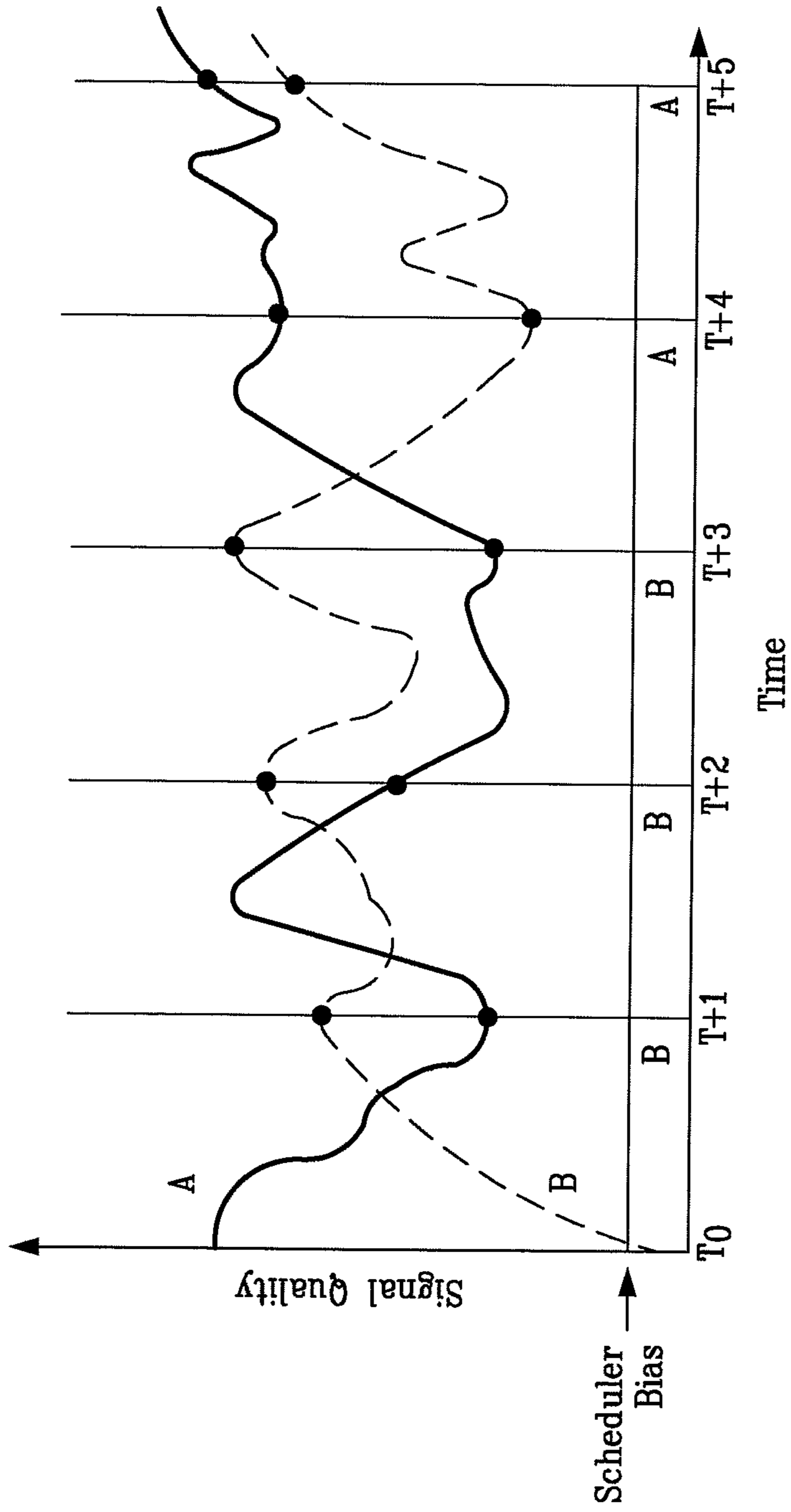
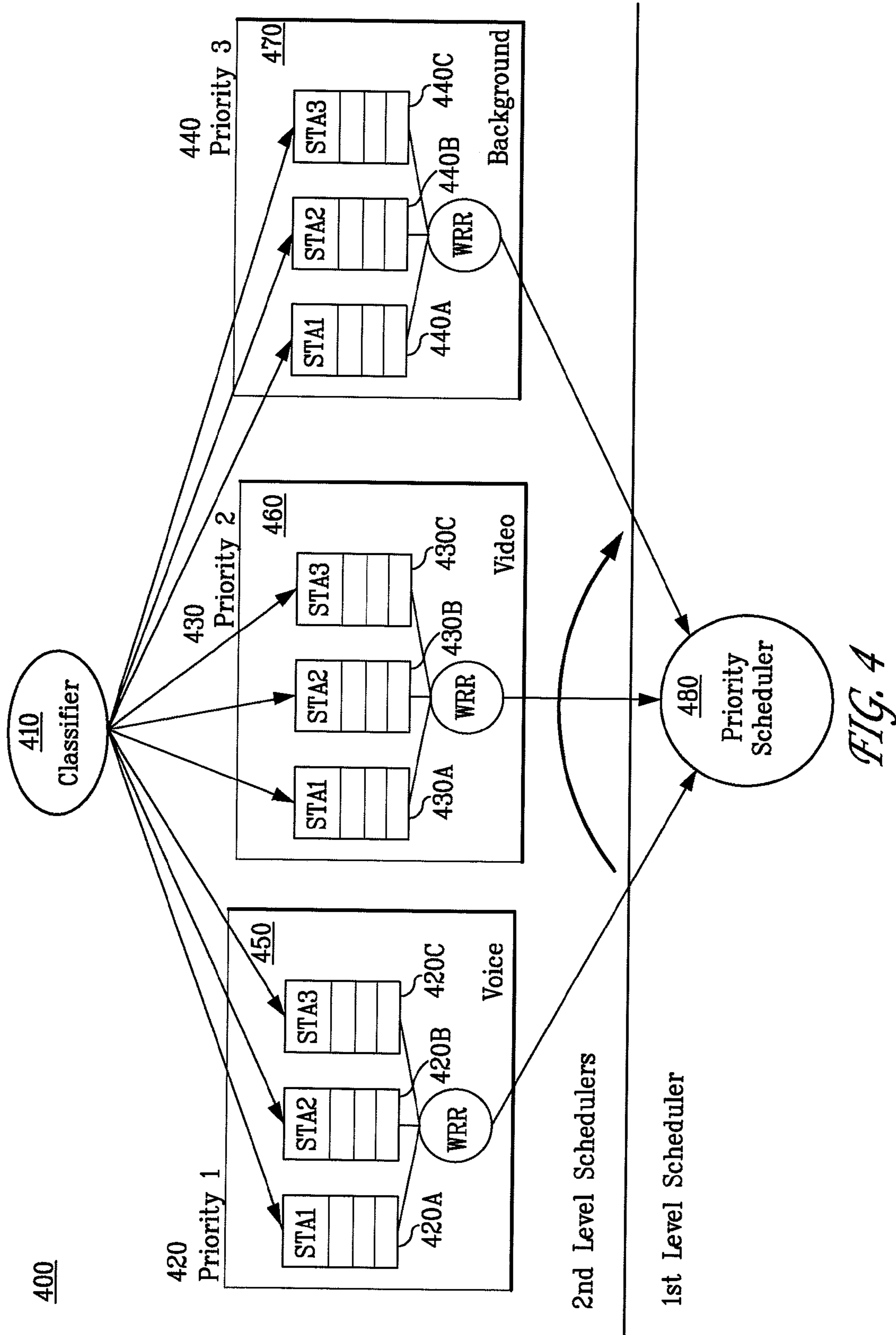

FIG. 3



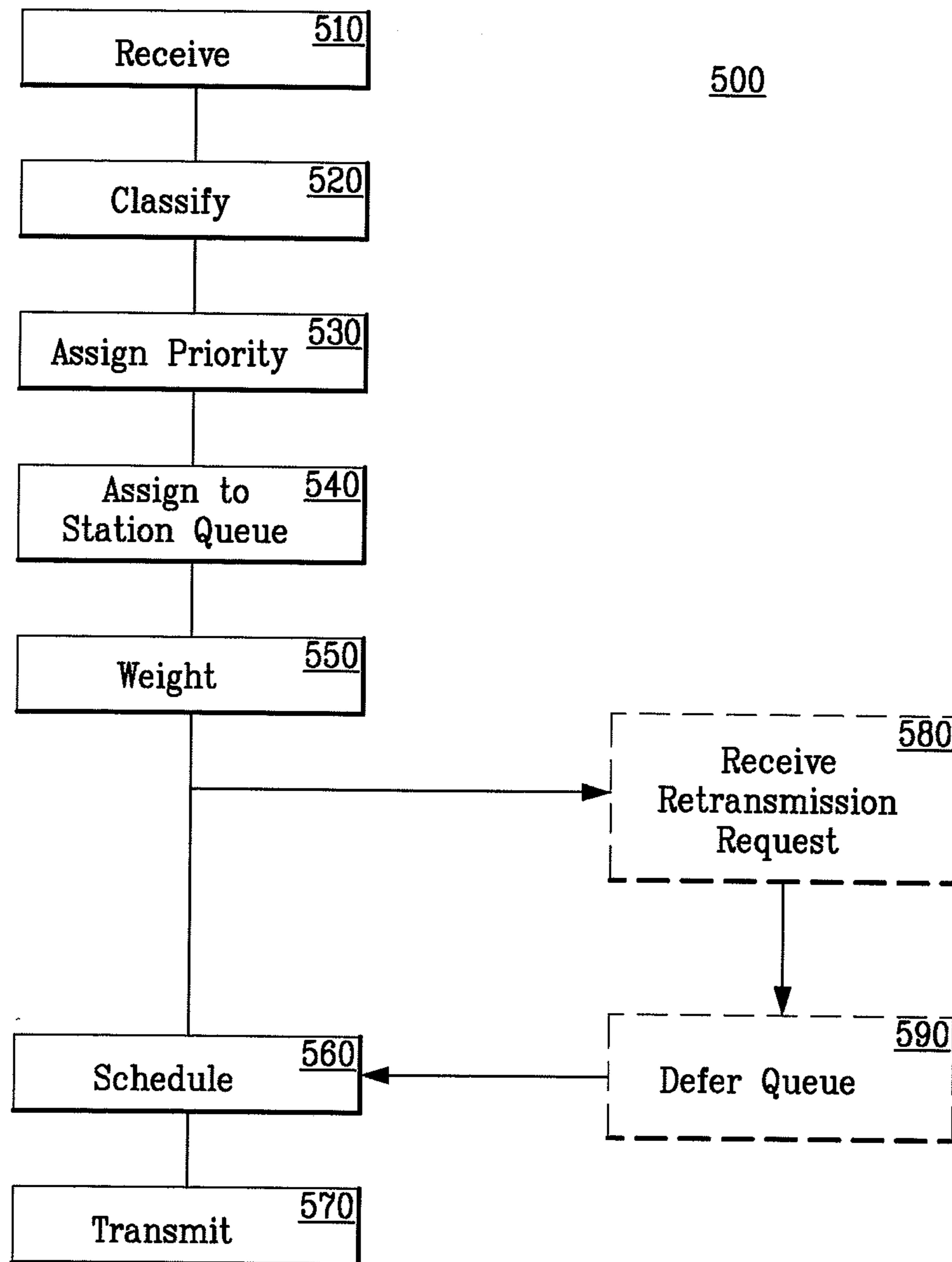

FIG. 5

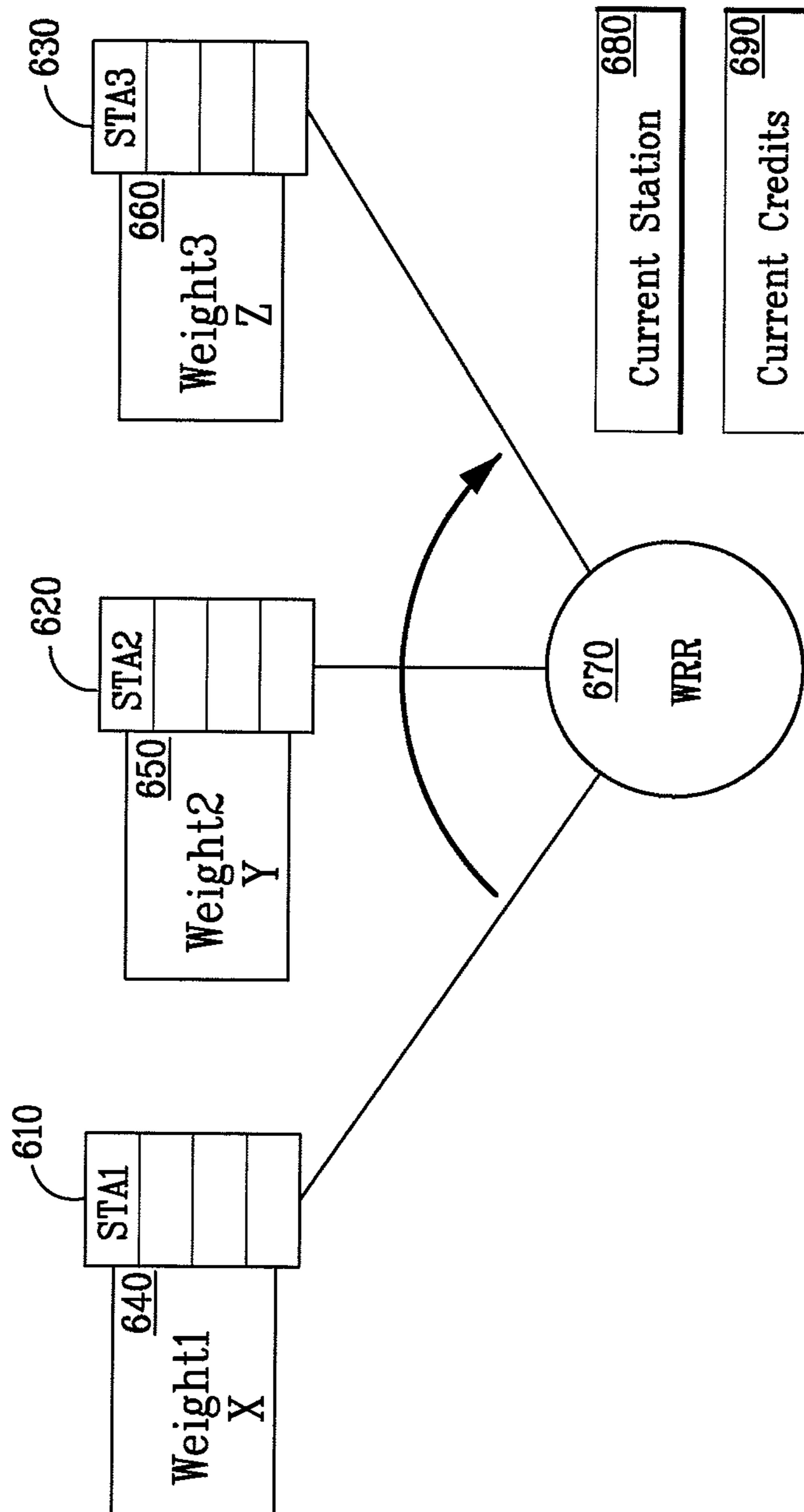

FIG. 6

**WIRELESS NETWORK THROUGHPUT
ENHANCEMENT THROUGH CHANNEL
AWARE SCHEDULING**

CROSS-REFERENCE TO RELATED
APPLICATIONS

The present application is a continuation and claims the priority benefit of U.S. patent application Ser. No. 12/181,274 filed Jul. 28, 2008, which will issue as U.S. Pat. No. 8,547,899 on Oct. 1, 2013, which claims the priority benefit of U.S. provisional application No. 60/952,557 filed Jul. 28, 2007, the disclosures of which are incorporated herein by reference.

BACKGROUND OF THE INVENTION

1. Field of the Invention

The present invention generally relates to communications networks. More particular, the present invention related to systems and method for increased data throughput in communications networks.

2. Description of the Related Art

A wireless channel is generally understood as a pathway between two communication endpoints. Through a wireless channel, the communication of any number of forms of data may take place. The efficient and effective communication of data is, however, subject to any number of characteristics of a particular wireless channel.

For example, a wireless channel with low throughput would not be recommended for the communication of data related to a high-definition television program. Similarly, the use of a wireless channel with a large amount of available bandwidth may be better utilized in the context of time-sensitive data transfers (e.g., voice communications) rather than the exchange of low priority and low-bandwidth background data queries.

Characteristics of a wireless channel may vary over time. For example, a wireless channel that at one moment has available bandwidth may subsequently be subjected to bottlenecks and dropped data packets thus requiring retransmission of the same. These variances in network characteristics may be a result of, for example, terminal mobility, multipath fading, or interference.

With respect to terminal mobility, a terminal may (while in motion) access wireless services from different locations. The mobility of the terminal requires the network to expend resources related to identifying and locating that terminal. The accessing of the network at different locales over time in conjunction with the need of the network to identify and locate the terminal may affect the quality of a wireless signal in that network.

Multipath fading involves the phenomenon of multipath propagation whereby a radio signal arrives at a receiving station (e.g., an antenna), at different times, via two or more paths. Multipath propagation may be induced by the refracting and reflecting of a wireless signal by various objects in the wireless environment (e.g., walls and metal objects). As a result of multipath propagation, the wireless signal is distorted thereby resulting in a deteriorated communications experience, which may include jitter or ghosting in the case of audio or video content.

Interference, broadly stated, may be mobile or static. In the case of mobile interference, the reception of a signal by a first mobile device (e.g., a wireless terminal) may be impeded or degraded by the transmission of a signal by another mobile device. Static interference is representative of the superposition of white noise (i.e., static) and other disturbing influences

on a wireless signal. These influences are inclusive of thermal noise, electronic noise from receiver input circuits, and radiated electromagnetic noise that might be picked up by a receiving station's antenna.

FIG. 1A illustrates how characteristics of a wireless channel may vary over time in light of the aforementioned terminal mobility, multipath fading, and interference. FIG. 1A illustrates a wireless channel **100** where signal quality **110** between an access point (AP) and station are illustrated as a function of time **120**. As can be seen from FIG. 1A, signal quality **110** is less at T+1 than at T+2. The signal quality **110** for T+1 and T+2 is less than the signal quality **110** illustrated at T+3, which is nearly equivalent to that of the signal quality **110** exhibited at T+4. Signal quality **110** improves at T+5 while experiencing a significant decrease at T+6.

Further complicating the understanding of wireless channel characteristics (and the optimal use of those channels) is that channel conditions often lack correlation amongst one another in a network of stations. The lack of correlation may be a result of different distances from an AP to a particular station, distances from a station (or the AP) to a particular source of interference, the movement of a mobile terminal or station, as well as varying multipath fading effects. FIG. 1B is exemplary in this regard with respect to illustrating the signal quality **110** between the aforementioned AP and Station A (**130**) and the AP and Station B (**140**). As shown in FIG. 1B, there is no immediately recognizable correlation in signal quality vis-a-vis the AP and the differing stations (**130/140**).

One attempt at managing variances in wireless channel characteristics, especially as they pertain to different stations, has been through the use of a scheduler. Schedulers may be embodied in hardware and/or software components—the latter being executable from memory or a storage device by a corresponding processing device—with respect to providing scheduling policies, rules, procedure, or other criteria in making scheduling decisions. A scheduler may, in light of the aforementioned policies or criteria and a given set of packets, select particular packets for serial transmission over a particular wireless channel.

Different scheduling policies may be used in an attempt to ensure a communications network's ability to provide different quality of service (QOS) guarantees. Policies may include strict priority (SP) where a particular station queue is always allocated bandwidth and/or transmitted before other queues. An alternative policy includes round robin (RR) scheduling, which assigns bandwidth and transmits packets in equal portion, in order, and without priority to a particular station queue.

Weighted round robin (WRR), on the other hand, is a best-effort scheduling discipline (i.e., the network does not provide any guarantees that data is delivered or that a user is given a guaranteed QOS level or priority). Through WRR scheduling, station queues can be assigned a weight—an integer value that might indicate capacity or priority. Station queues with higher weights have their packets transmitted prior to those with lesser weights. All queues are eventually given regular transmission access to a channel albeit it those queues with higher weight will get more transmission access attempts than those with lesser weights.

Yet another scheduling policy is fair queuing (FQ), which allows several packet flows to fairly share link capacity. Fair queuing differs from first-in-first-out (FIFO) (i.e., what comes in first is handled first and what comes in next waits until the first is finished) in that an ill-behaved flow that consists of, for example, large data packets or a large number of packets will punish itself and not other packet flows. In FQ scheduling, in order to decide which packet should be for-

warded first, the FQ algorithm estimates a virtual finishing time of all candidate packets (i.e., the packets at the head of all non-empty queues) based on, for example, the arrival time of the packet, the packet size, and the number of queues. The FQ scheduling algorithm or policy then compares the virtual finishing time and selects the minimum one. The packet with the minimum virtual finishing time is transmitted.

A still further scheduling policy is weighted fair queuing (WFQ), which allows different scheduling priorities to be statistically multiplexed. WFQ is a generalization of the aforementioned FQ algorithm where each data flow has a separate FIFO queue. Whereas the aforementioned ill-behaved queue will only punish itself, WFQ allows different sessions to have different service shares. If N data flows currently are active, with weights $\omega_1, \omega_2, \dots, \omega_N$, data flow number i will achieve an average data rate of

$$\frac{R\omega_i}{(\omega_1 | \omega_2 | \dots | \omega_N)}$$

An end-to-end delay bound can be guaranteed in WFQ scheduling. By dynamically regulating WFQ weights, this policy can be used to control QOS and achieve a guaranteed data rate.

Typical wireless devices (e.g., an 802.11x compliant device) implement a simple class and/or priority scheduling mechanism with a FIFO queue per each traffic class. An example of such a mechanism **200** is illustrated in FIG. 2. The scheduling mechanism **200** of FIG. 2 illustrates four classes of traffic priority: voice (**230**), video (**240**), best-effort (**250**), and background (**260**). While the voice, video, best-effort, and background represent the typical four traffic priorities, the actual number of classes may vary in order to accommodate, for example, additional traffic classes and management traffic.

In the scheduling mechanism **200** of FIG. 2, packets are introduced to the wireless device via a network/input interface **210**. It should be noted that certain hardware components (e.g. a processor or memory) are not illustrated in that one skilled in the art will appreciate and understand the requisite components to implement the various applications disclosed herein. Packets may be received from another wireless device, a network backbone, a router, or a primary source of content that has been converted into data packets for transmission.

Packets are then routed to the classifier **220**. The classifier **220** may identify packets based on application layer data regardless of port. The classifier **220** may alternatively identify packets based on Internet Protocol (IP) address, port numbers, and so on. Packet classification based on multiple fields may be implemented using basic search algorithms, geometric algorithms, heuristic algorithms, or hardware-specific search algorithms. A variety of methodologies for packet classification are generally known in the art.

Once classified by classifier **220**, packets are then routed to an appropriate queue: voice, video, best-effort, background (**230-260**). The priority scheduler **270** then schedules the classified and queued packets. In the priority based queuing and scheduling mechanism **200** of FIG. 2, all packet traffic of a specific class (e.g., voice (**230**)) is subjected to FIFO queuing. Scheduling is done strictly by priority (SP). As such, priority N (e.g., voice (**230**)) must be empty before priority $N+1$ (e.g., video (**240**)) is allowed to transmit. Packets are then transmitted or further routed via the appropriate network/output interface **280**.

Problems exist with respect to prior art scheduling methodologies based on priority queuing with per class FIFO. Channel aware scheduling (as discussed in further detail below) may not be implemented in this context. For example, traffic to different stations is interleaved within each FIFO queue. Further, only one packet is available at any given time—the packet at the head of the highest priority queue.

Typical prior art scheduler implementations also blindly retransmit the head end packet from the highest priority active queue until that packet is either successfully acknowledged by the recipient or some maximum number of retransmissions occurs. This blind retransmission causes head-of-line blocking. As a result, poor system performance results and, in many circumstances, clients may become completely impaired.

SUMMARY OF THE PRESENTLY CLAIMED INVENTION

An embodiment of the presently claimed invention includes a system for increasing wireless network throughput. The system includes a classifier configured to assign a packet to one of a plurality of transmission queues. The system further includes a first scheduling module and a second scheduling module. The first scheduling module is stored in a computer-readable medium and executable by a processing device to select an assigned packet for transmission from one of the plurality of transmission queues in accordance with a strict priority schedule. The second scheduling module is likewise stored in a computer-readable medium and executable to select a priority scheduled packet for transmission, wherein the selection is made in accordance with a weighted scheduling technique.

In a second embodiment of the presently claimed invention, a method for increasing wireless throughput is disclosed. The method includes the steps of assigning a packet to one of a plurality of transmission queues; selecting an assigned packet for transmission from one of the plurality of transmission queues in accordance with a priority schedule; selecting a priority scheduled packet for transmission in accordance with a weighted scheduling technique; and transmitting the packet.

A third embodiment is for a computer-readable storage medium having embodied thereon a program. The program is executable by a processing device to perform a method for increasing wireless throughput, the method includes the steps of assigning a packet to one of a plurality of transmission queues; selecting an assigned packet for transmission from one of the plurality of transmission queues in accordance with a priority schedule; selecting a priority scheduled packet for transmission in accordance with a weighted scheduling technique; and transmitting the packet.

BRIEF DESCRIPTION OF THE DRAWINGS

FIG. 1A illustrates a wireless channel where signal quality between an access point and station are shown as a function of time.

FIG. 1B illustrates signal quality between an access point and two stations.

FIG. 2 illustrates a class/priority scheduling mechanism with a FIFO queue for each traffic class.

FIG. 3 illustrates the biasing of a scheduler in a channel aware scheduler network environment involving an AP and two stations.

FIG. 4 illustrates an embodiment of a channel aware scheduling mechanism utilizing hierarchical schedulers.

5

FIG. 5 illustrates a method for channel aware scheduling transmission including a channel aware scheduler mechanism utilizing a deferred retransmission module.

FIG. 6 illustrates queue weighting as may occur in the context of the channel aware scheduler mechanism of FIG. 4 and the corresponding method of FIG. 5.

DETAILED DESCRIPTION

The presently disclosed invention utilizes channel aware scheduling. Through channel aware scheduling, an optimized scheduler—a channel aware scheduler (CAS)—takes advantage of changing wireless channel conditions in order to maximize aggregated system throughput. A CAS is aware of the different channel conditions for one or more stations and adjusts its scheduling of packet transmissions in light of the same. The CAS algorithm may take advantage of that knowledge in order to increase aggregated system throughput while concurrently addressing other potential fairness constraints.

FIG. 3 illustrates an example of how a CAS may be beneficial in a network environment 300 involving an AP and two stations (A and B). Based on the particular signal quality for each station (A or B) over time ($T=0$, $T+1$, $T+N$), the scheduler is biased toward one station or the other (i.e., the scheduler is aware of the quality of both channels). For example, at time $T+1$, $+2$ and $+3$, the scheduler is biased toward station B while at time $T+4$ and $T+5$, the scheduler is biased to station A.

The CAS mechanism of the present invention allows for finer queuing and scheduling granularity with respect to individual stations and packet flows. An embodiment of the present invention utilizes hierarchical scheduling. In a first level of the hierarchy, an SP scheduling algorithm may be employed as is common to enterprise and service-provider class networking equipment. In a second level, the CAS mechanism may utilize WRR or WFQ scheduling algorithms as described above.

FIG. 4 illustrates an embodiment of a CAS mechanism 400 utilizing the aforementioned hierarchical schedulers. Packets are received at classifier 410 following initial receipt by a network/input interface. Classifier 410 may operate in a manner similar to classifier 220 as illustrated in FIG. 2.

Following classification of an incoming packet at a wireless device implementing the CAS mechanism 400 of FIG. 4, the packet is routed to a first part of the scheduling hierarchy (i.e., a second level scheduler). In FIG. 4, this first portion of the scheduling hierarchy is represented by a queue with an associated priority. The CAS mechanism 400 of FIG. 4 illustrates three priority queues, which may be representative of voice, video, and background (420-440, respectively). Differing numbers of priority queues may be implemented subject to the particular type of packet flows being received at the CAS mechanism 400. For example, if the wireless device implementing CAS mechanism 400 is dedicated to the delivery of Internet Packet Television (IPTV) content, the voice queue (420) may be omitted.

Corresponding to each priority queue (420-440) in FIG. 4 is one or more station queues (420A-420C; 430A-430C; and 440A-440C). Each of the station queues 420A-420C; 430A-430C; and 440A-440C operates in conjunction with a WRR mechanism (450-470). Utilizing an associated WRR mechanism, each station queue 420A-420C; 430A-430C; and 440A-440C is assigned a weight indicative of capacity or priority. Station queues 420A-420C; 430A-430C; and 440A-440C with higher weights will have their packets transmitted

6

prior to those with lesser weights. Weighting of a station queue is discussed in greater detail with respect to FIG. 6 below.

Following assignment to a priority and weighted station queue in the first portion of the hierarchy, the priority scheduler 480 of the second portion of the hierarchy (i.e., the first level scheduler) assumes responsibility for scheduling the transmission of the classified, prioritized, weighted, and queued packets. The priority scheduler 480 of FIG. 4 may operate in a fashion similar to that of the priority scheduler 270 in FIG. 2. Packets are then transmitted or further routed via an appropriate network/output interface.

In some embodiments, the CAS mechanism 400 of FIG. 4 may utilize additional scheduling techniques such as deferred retransmission and weighted feedback. Both of these techniques may be implemented in the context of the second level schedulers of FIG. 4.

In the case of deferred retransmission, an indication of a failed transmission may be used to temporarily defer transmission or retransmission to the failed station and instead service other active stations in a priority queue. A deferred retransmission module may make direct use of a standard retransmission request mechanism such as an 802.11 acknowledgment (ACK) that would indicate a retransmission is required when no ACK is received.

Alternatively, an Automated Repeat Request (ARQ), which uses acknowledgments and timeouts to achieve reliable data transmission, may be used. A Hybrid Automated Repeat Request (HARQ) may also be used. In standard ARQ, error-detection information (ED) bits are added to data to be transmitted, such as cyclic redundancy check (CRC). In HARQ, forward error correction (FEC) bits are also added to the existing ED bits, such as Reed-Solomon code or Turbo code. As a result HARQ performs better than ordinary ARQ in poor signal conditions but may adversely affect the environment in good signal conditions. HARQ may have particular applicability to the IEEE 802.16-2005 standard for mobile broadband wireless access, also known as 'mobile WiMAX.' HARQ mechanisms also tend to be implemented in hardware.

The absence of an ACK or the receipt of an ARQ or HARQ (i.e., a retransmission request) operates as an indication of packet corruption. Packet corruption, in turn, is an indication of potential channel fade or other adverse channel condition. Upon indication of a retransmission requirement, the second level scheduler mechanism may elect to defer retransmission and move on to the next queue station that has pending packets.

FIG. 5 illustrates a method for CAS transmission in accordance with the CAS mechanism 400 of FIG. 4 as well as a CAS mechanism utilizing a deferred retransmission module.

In step 510, a packet is received. Receipt of the packet may occur via a network/input interface. Packets may be received from another wireless device, a network backbone, a router, or a primary source of content that has been converted into data packets for transmission.

In step 520, received packets are classified. The packets may be classified based on an application layer data regardless of port. Packets may also be identified and subsequently classified based on IP address, port numbers, and so on. Packet classification based on multiple fields may be implemented using basic search algorithms, geometric algorithms, heuristic algorithms, or hardware-specific search algorithms.

In step 530, packets are routed to an appropriate priority queue. Packets are then assigned to a station queue in step 540. Weighting of the station queues takes place in step 550. It should be noted that station queue weighting may be dynamic or static and may take place prior to or concurrent

with the transmission of any particular packet or packet flow. Weighting of a station queue is discussed further with respect to FIG. 6. Packets are scheduled solely based on priority in 560 and transmitted in accordance with that priority in step 570.

In an alternative embodiment of a CAS mechanism that utilizes a deferred retransmission module, a retransmission request is received at optional step 580. In response to the retransmission request, a particular station queue is deferred in optional step 590. Scheduling of the remaining priority and channel queues takes place in step 560 as would occur in an embodiment not utilizing a deferred retransmission module. Transmission of the scheduled packets takes place in step 570.

FIG. 6 illustrates queue weighting as may occur in the context of the CAS mechanism of FIG. 4 and the corresponding method of FIG. 5. Using a WRR algorithm, a weight (640-660) is determined for each queue (610-630). The WRR scheduler 670 (e.g., WRR 450) then round robins between active queues (those that have pending packets) and transmits up to N packets from a queue where N is the weight associated with that queue.

Weighting may be implemented via credit register 690 that is loaded with a particular weight when a new station queue 680 is selected. The credit register 680 is decremented with each transmission from that station queue 680. When the credit register 690 reaches 0, the WRR scheduler 670 advances in a round robin fashion to the next queue with an associated load of credits.

An embodiment of the CAS mechanism utilizing a deferred retransmission module may modify the WRR scheduler 670 as follows. Upon receipt of a retransmission requirement, it is determined from which station queue the failed packet originated. The failed packet is then re-queued at the head of that queue. If that particular queue is still active (i.e., the queue still has credits), the queue is penalized through the additional decrement of the credit register or decrementing the credit register to zero thereby forcing an activation of a queue associated with a different station. These penalization activities may take place in the context of optional step 590 of FIG. 5.

A further embodiment of the CAS mechanism disclosed herein may implement weighted feedback, which may be applicable to a hierarchical implementation utilizing WFQ or WRR. In such an embodiment, per-station channel conditions are estimated. These estimates may utilize low-level metrics such as signal-to-noise ratio (SNR) or error-to-vector magnitude (EVM). Application level metrics such as estimated throughput may also be utilized. Queue weights are modified to reflect channel conditions such that the scheduler favors stations with the better channel. Generally, weights are proportional to each channel capacity in order to maximize throughput. Weights may be limited to some minimal value to prevent the starvation of poor stations.

A still further embodiment of weight feedback involves, for each associated station, the performance of throughput estimation. Estimation may occur using a throughput model and packet encoding rule (PER) statistics. Packet transmission time stamps may also be used. If the estimated throughput is below some minimum threshold, the estimated throughput is set to the minimum threshold in order to ensure that some minimal bandwidth allocation is made with respect to each station. The WRR or WFQ weight is scaled proportionally to the estimated throughput.

Computer-executable instructions and associated data structures represent examples of the programming means for executing steps of the methods and implementing particular

system configurations disclosed herein. Such methodologies may be stored in a computer-readable storage medium. Such methodologies may be executed in the context of a corresponding processing device.

While the present invention has been described in the context of a series of exemplary embodiments, these descriptions are not intended to limit the scope of the invention to the particular forms set forth herein. To the contrary, the present description is intended to cover such alternatives, modifications, and equivalents as may be included within the spirit and scope of the invention as defined by the appended claims and otherwise appreciated by one of ordinary skill in the art.

What is claimed is:

1. A system for increasing wireless network throughput, the system comprising:

a classifier configured to assign a packet to one of a plurality of transmission queues; and

a hierarchical scheduling module stored in a computer-readable storage medium and executable by a processing device, the hierarchical scheduling module configured to:

select a priority scheduled packet for transmission, wherein the selection is made in accordance with a weighted scheduling technique utilizing weighted round robin for determining a weight for each transmission queue,

assign queue weights to stations within each transmission queue,

determine from which of the plurality of transmission queue a failed packet originated,

requeue the failed packet for retransmission at the queue from which the failed packet is determined to have originated, and

penalize a credit register of the determined queue, wherein a transmission queue is activated at a different station when penalizing the credit register of the determined queue results in a predetermined level.

2. The system of claim 1, wherein the failed packet is requeued at a head of the queue from which the failed packet is determined to have originated.

3. The system of claim 1, wherein retransmission of the failed packet is deferred.

4. The system of claim 1, wherein the assigned queue weights are modified based on one or more current channel conditions associated with each transmission queue.

5. The system of claim 4, wherein the modification to each of the queue weights is proportional to an associated channel capacity.

6. The system of claim 4, wherein the modification is limited to a predetermined minimal value.

7. The system of claim 4, wherein the modification to each of the queue weights is proportional to an estimation of throughput performance.

8. The system of claim 7, wherein the estimation of throughput performance is based on at least one of a throughput model, packet encoding rule, and packet transmission time.

9. A method for increasing wireless network throughput, the method comprising:

assigning a packet to one of a plurality of transmission queues; and

executing a hierarchical scheduling module stored in a computer-readable storage medium, wherein execution of the hierarchical scheduling module by a processing device:

selects a priority scheduled packet for transmission, wherein the selection is made in accordance with a

9

weighted scheduling technique utilizing weighted round robin for determining a weight for each transmission queue,
 assigns queue weights to stations within each transmission queue,
 determines from which of the plurality of transmission queues a failed packet originated,
 requeues the failed packet for retransmission at the queue from which the failed packet is determined to have originated, and
 penalizes a credit register of the determined queue, wherein a transmission queue is activated at a different station when penalizing the credit register of the determined queue results in a predetermined level.

10. The method of claim 9, wherein the failed packet is requeued at a head of the queue from which the failed packet is determined to have originated.

11. The method of claim 9, further comprising deferring retransmission of the failed packet.

12. The method of claim 9, further comprising modifying the assigned queue weights based on one or more current channel conditions associated with each transmission queue.

13. The method of claim 12, wherein the modification to each of the queue weights is proportional to an associated channel capacity.

14. The method of claim 12, further comprising limiting the modification to a predetermined minimal value.

15. The method of claim 12, wherein the modification to each of the queue weights is proportional to an estimation of throughput performance.

10

16. The method of claim 15, wherein the estimation of throughput performance is based on at least one of a throughput model, packet encoding rule, and packet transmission time.

17. A non-transitory computer-readable storage medium, having embodied thereon a program executable by a processor to perform a process for increasing wireless network throughput, the process comprising:

assigning a packet to one of a plurality of transmission queues;

selecting a priority scheduled packet for transmission, wherein the selection is made in accordance with a weighted scheduling technique utilizing weighted round robin for determining a weight for each transmission queue;

assigning queue weights to stations within each transmission queue;

determining from which of the plurality of transmission queue a failed packet originated;

requeuing the failed packet for retransmission at the queue from which the failed packet is determined to have originated; and

penalizing a credit register of the determined queue, wherein a transmission queue is activated at a different station when penalizing the credit register of the determined queue results in a predetermined level.

* * * * *