



US009271266B2

(12) **United States Patent**
Frederiksen et al.

(10) **Patent No.:** **US 9,271,266 B2**
(45) **Date of Patent:** **Feb. 23, 2016**

(54) **SEARCHING FOR CONTROL CHANNELS IN A WIRELESS NETWORK**

(75) Inventors: **Frank Frederiksen**, Klarup (DK);
Troels Emil Kolding, Klarup (DK)

(73) Assignee: **WIRELESS FUTURE TECHNOLOGIES INC.**, Ottawa, Ontario (CA)

(*) Notice: Subject to any disclaimer, the term of this patent is extended or adjusted under 35 U.S.C. 154(b) by 898 days.

(21) Appl. No.: **12/451,350**

(22) PCT Filed: **May 6, 2008**

(86) PCT No.: **PCT/EP2008/055557**

§ 371 (c)(1),
(2), (4) Date: **Mar. 2, 2010**

(87) PCT Pub. No.: **WO2008/135575**

PCT Pub. Date: **Nov. 13, 2008**

(65) **Prior Publication Data**

US 2010/0208666 A1 Aug. 19, 2010

(30) **Foreign Application Priority Data**

May 7, 2007 (EP) 07107652

(51) **Int. Cl.**

H04W 4/00 (2009.01)

H04B 7/216 (2006.01)

H04W 72/04 (2009.01)

H04B 7/26 (2006.01)

(52) **U.S. Cl.**

CPC **H04W 72/0406** (2013.01); **H04B 7/2637** (2013.01)

(58) **Field of Classification Search**

CPC H04W 72/406; H04B 7/2637
See application file for complete search history.

(56) **References Cited**

U.S. PATENT DOCUMENTS

2006/0120322	A1	6/2006	Lindskog et al.	
2008/0159323	A1*	7/2008	Rinne et al.	370/431
2008/0163002	A1*	7/2008	Frederiksen	714/37
2008/0188247	A1*	8/2008	Worrall	455/458
2009/0325585	A1*	12/2009	Farajidana et al.	455/450
2010/0067445	A1*	3/2010	Rinne et al.	370/329

FOREIGN PATENT DOCUMENTS

EP	0575281	B1	11/1999
EP	1313228	A2	5/2003
KR	2003-0041468	A	5/2003
KR	2006-0039865	A	5/2006

(Continued)

OTHER PUBLICATIONS

J. Zyren; "Overview of the 3GPP Long Term Evolution Physical Layer"; White Paper from freescale semiconductor, Jul. 2007; pp. 1-25.

(Continued)

Primary Examiner — Steven H Nguyen

(74) *Attorney, Agent, or Firm* — Volpe and Koenig, P.C.

(57) **ABSTRACT**

A user equipment (UE) may receive an OFDM signal having control channel elements (CCEs). The CCEs may be arranged in levels where a first level aggregates less CCEs than a second level. A processor may search for a control channel from control channel candidates that is comprised of the CCEs. A limited number of CCEs may be searched on the first level.

12 Claims, 5 Drawing Sheets

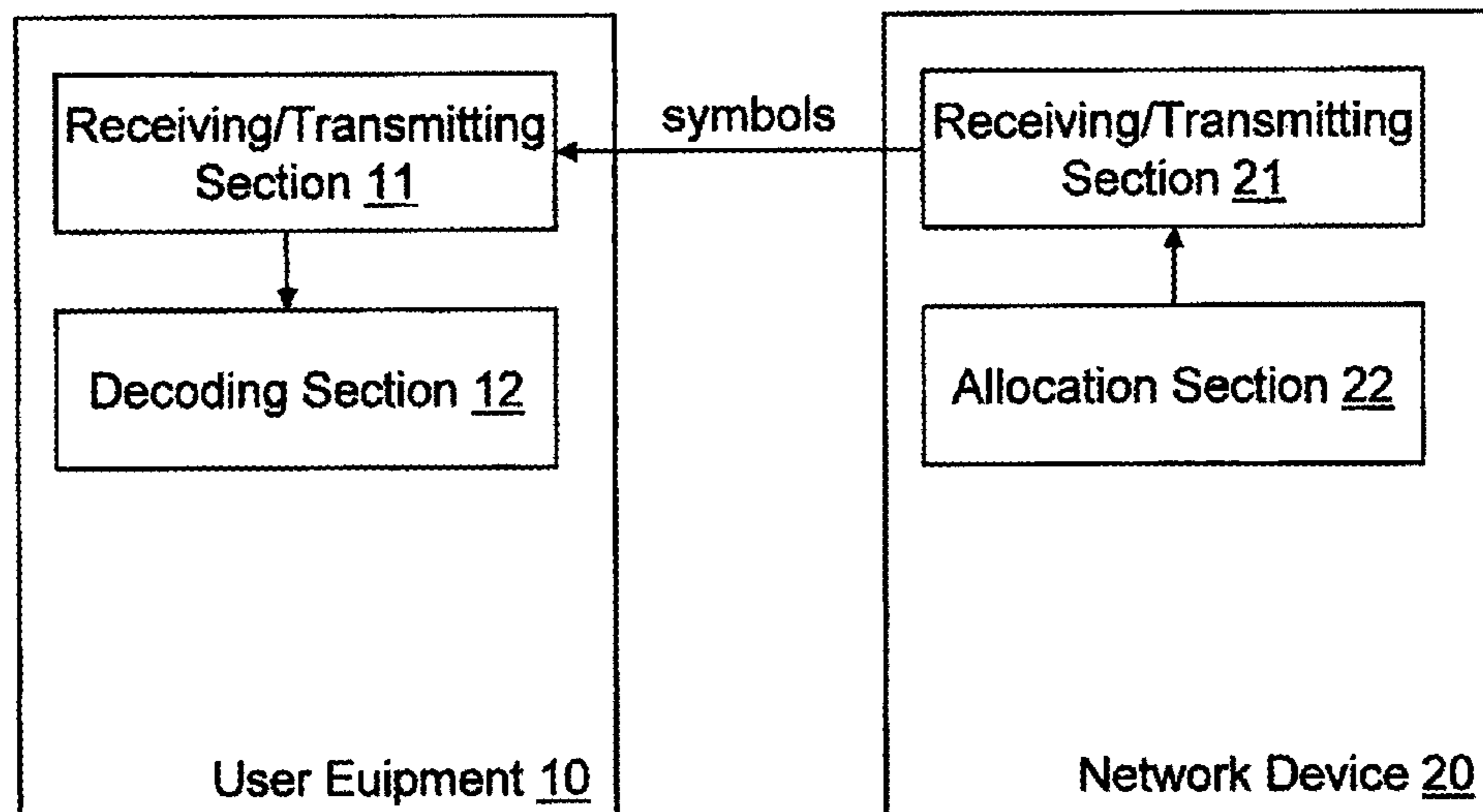

(56)

References Cited

FOREIGN PATENT DOCUMENTS

RU	2216107 C2	11/2003
RU	2280951 C2	7/2006
WO	2007/051186 A2	5/2007

OTHER PUBLICATIONS

Physical Channel Structure and Procedure for EUTRA Downlink; 3GPP TSG-RAN WG1 Meeting #42, Tdoc R1-050884; Sep. 2005; pp. 1-18.

“E-UTRA Downlink Control Channel Structure and TP”; 3GPP TSG RAN1#44 R1-06378; Feb. 2006; 7 pp.

“EUTRA SC-FDMA Uplink Resource Block, Resource Allocation and Pilot/Reference Signal Design & TP”; 3GPP TSG RAN1 LTE Ad Hoc; R1-060246; Jan. 2006; pp. 1-18.

Universal Mobile Telecommunications System (UMTS): Evolved Universal Terrestrial Radio Access (E-UTRA) and Evolved Universal Terrestrial Radio Access Network (E-UTRAN); Overall description; Stage 2 (3GPP TS 36.300 V 8.0.0 Release 8) 3rd Generation

Partnership Project; Technical Spec Group Radio Access Network, Mar. 2007; pp. 1-83.

International Search Report for Application No. PCT/EP2008/05557; mailed Sep. 15, 2008.

European Search Report for Application No. EP07107652.5-1249; dated Nov. 27, 2007.

“3rd Generation Partnership Project; Technical Specification Group Radio Access Network; Physical Layer Procedures”, Release 8, 3GPP TS 36.213, V1.0.0, Mar. 2007, pp. 1-11.

Notice of Allowance issued Dec. 19, 2011 in corresponding Korean Application No. 10-2009-7025561.

Office Action issued Mar. 26, 2013 in corresponding Russian Application No. 2009145117/07.

English Abstract of Korean Patent Application No. 2006-0039865 dated May 9, 2006.

Third Generation Partnership Project, “Technical Specification Group Radio Access Network; Multiplexing and channel coding (Release 8),” 3GPP TS 36.212 V1.0.0 (Mar. 2007).

Third Generation Partnership Project, “Technical Specification Group Radio Access Network; Physical Channels and Modulation (Release 8),” 3GPP TS 36.211 V1.0.0 (Mar. 2007).

* cited by examiner

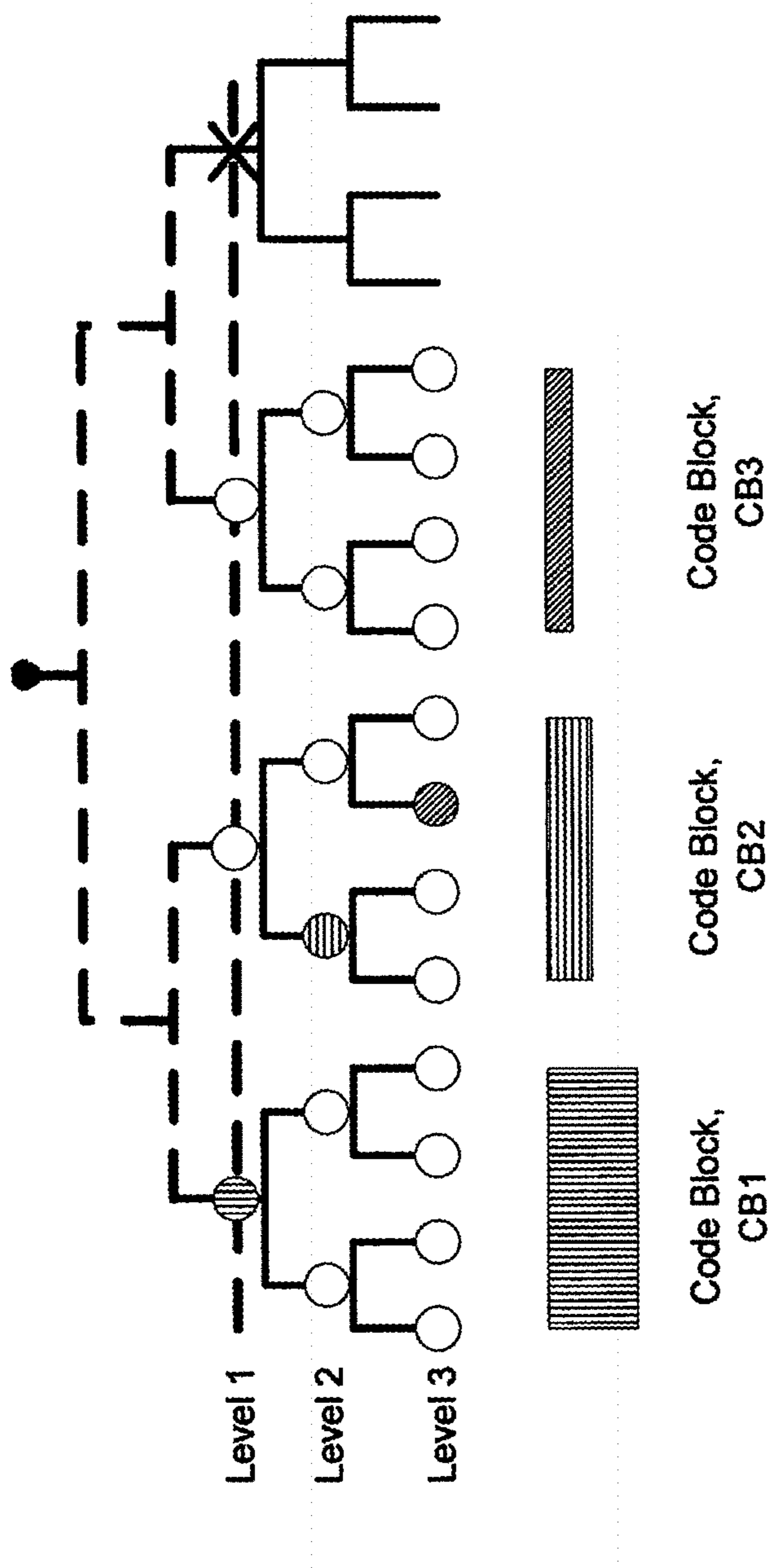

Fig. 1

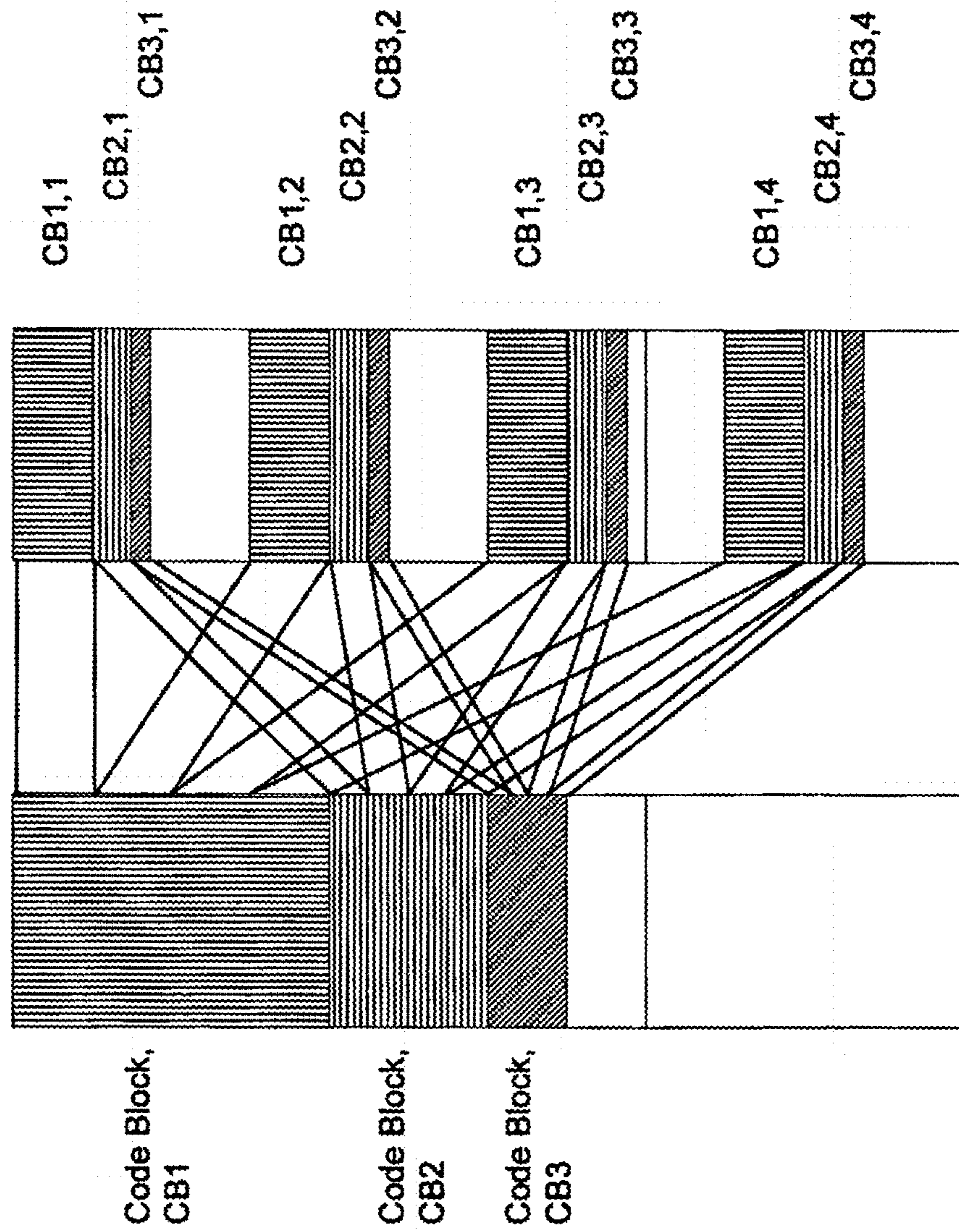

Fig. 2

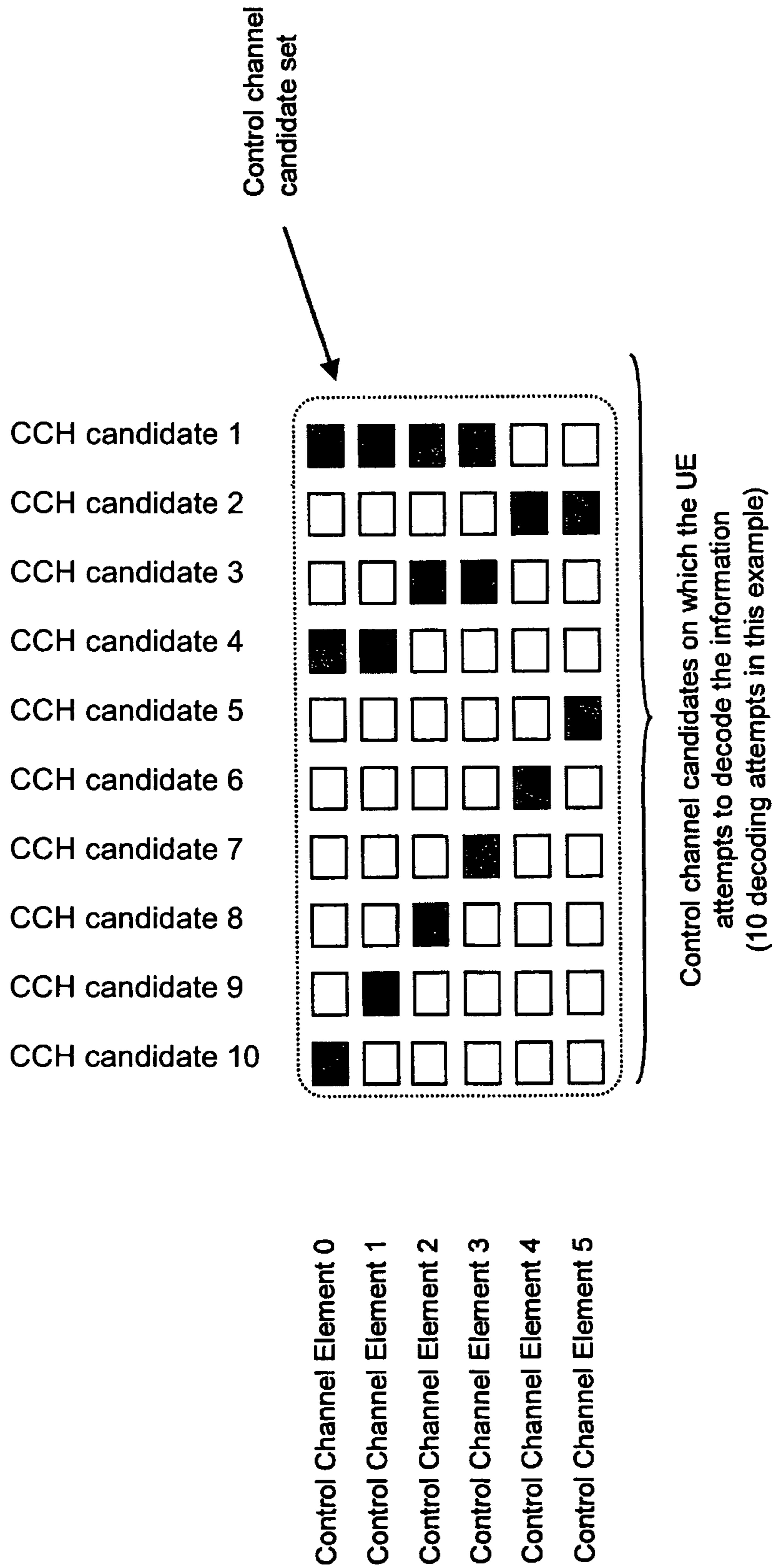

Fig. 3

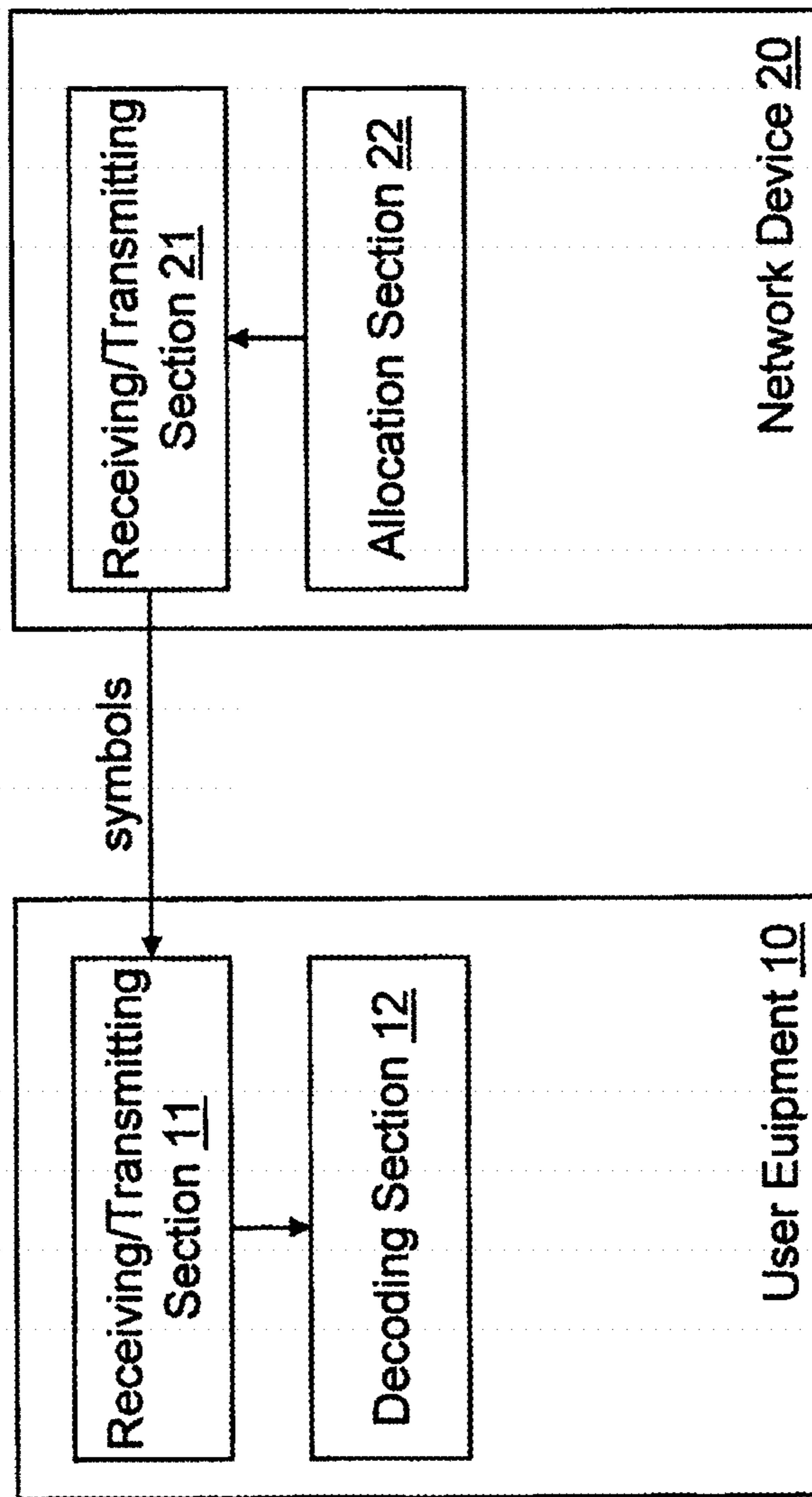

Fig. 5

SEARCHING FOR CONTROL CHANNELS IN A WIRELESS NETWORK

CROSS REFERENCE TO RELATED APPLICATIONS

This application is the U.S. national stage of International Application No. PCT/EP2008/055557, filed May 6, 2008 and claims the benefit thereof. The International Application claims the benefits of European Application No. 07107652 filed on May 7, 2007, both applications are incorporated by reference herein in their entirety.

BACKGROUND

The method described below relates to control channels in communication network systems, and in particular to control channel allocation and decoding e.g. in 3GPP (3rd Generation Partnership Project) LTE (Long Term Evolution) network systems.

LTE technology, for example, defines a packet radio system, where all channel allocations are expected to happen in short periods of sub-frames. This is contrary to the older 3G systems, where dedicated signalling channels are necessary to be set up even for packet traffic. It is also different from WLAN (Wireless Local Area Network) type of allocations, where each IP (Internet Protocol) packet transmission contains a transport header.

According to LTE technology, all allocations are signalled in Shared Control Channels, which are present in first multi-carrier symbols of a sub-frame preceding multi-carrier symbols of data channels. The control channels are separately coded. That is, a downlink (or uplink) channel is divided into two separate parts, one for control and one for data. The data part (PDSCH) carries downlink (or uplink) data for simultaneously scheduled users, while the control part (PDCCH) carries (among others) allocation information for the scheduled users.

SUMMARY

The methods and devices described below are for reducing control channel decoding complexity. The method may be implemented as a computer program product.

Accordingly, a tree search for aggregated control channels is reduced in a systematic way, which will obtain a significant reduction of the number of decoding attempts at a UE (User Equipment) side, while still maintaining most of the scheduling flexibility in an eNB (evolved Node B), i.e. system spectral efficiency versus UE complexity trade-off is obtained.

Accordingly it is assumed that there will not be a large amount of users having the same propagation conditions being scheduled at the same time. The tree reduction is obtained by putting some limitations on the tree structure through specifications.

The UE utilizes the tree structure to reduce the decoding complexity in order to save power. According to an embodiment, power consumption in the decoding/detection of an L1/L2 control channel can be reduced.

For the purpose of the methods and devices described herein below, it should be noted that

a user equipment may for example be any device by which a user may access a communication network; this implies mobile as well as non-mobile devices and networks, independent of the technology platform on which they are based;

a user equipment can act as a client entity or as a server entity, or may even have both functionalities integrated therein;

methods likely to be implemented as software code portions and being run using a processor at one of the server/client entities are software code independent and can be specified using any known or future developed programming language;

methods and/or devices likely to be implemented as hardware components at one of the server/client entities are hardware independent and can be implemented using any known or future developed hardware technology or any hybrids of these, such as MOS, CMOS, BiCMOS, ECL, TTL, etc, using for example ASIC components or DSP components, as an example;

generally, any method is suitable to be implemented as software or by hardware without changing the idea of the present invention;

devices can be implemented as individual devices, but this does not exclude that they are implemented in a distributed fashion throughout the system, as long as the functionality of the device is preserved.

The method is not limited to LTE network systems, but can be applied to any other communication systems requiring dynamic and fast channel allocation, including systems where there will be multiple code rates for the control channel.

BRIEF DESCRIPTION OF THE DRAWINGS

These and other aspects and advantages will become more apparent and more readily appreciated from the following description of the exemplary embodiments, taken in conjunction with the accompanying drawings of which:

FIG. 1 is an example of a tree structure with three allocated nodes in different levels of the tree.

FIG. 2 is a data structure diagram of the three allocated nodes of FIG. 1 mapped to sub-carrier resources in a distributed manner.

FIG. 3 is a matrix diagram illustrating a combination of control channel elements to create aggregated control channel candidates.

FIG. 4 is a data structure diagram of an example illustrating reduction of possible aggregation options for control channel candidates according to an embodiment.

FIG. 5 is a schematic block diagram illustrating functions of a user equipment and a network device according to an embodiment.

DETAILED DESCRIPTION OF THE PREFERRED EMBODIMENT

Reference will now be made in detail to the preferred embodiments, examples of which are illustrated in the accompanying drawings, wherein like reference numerals refer to like elements throughout.

A Physical Downlink Shared Control Channel (PDSCCH) which carries (among others) allocation information for simultaneously scheduled users of a communication network system is arranged to a tree structure having of multiple control channel elements as shown in FIG. 1. During decoding, a UE (User Equipment) will combine or aggregate the control channel elements to create different code blocks or control channel candidates. Each code block is called a control channel candidate as it potentially carries information for one MAC (Medium Access Control) ID. The MAC ID is used by the UE or by a group of UEs to detect the channel. At each

level of the tree, each node represents a single control channel of a code block. The number of the control channels at the lowest level of the tree is determined by the system bandwidth and number of OFDM symbols n available for the largest code blocks, as well as the size of the control channel elements. In the example shown in FIG. 1, $n=3$. Any node of the tree, which is not occupied by a control channel in this level, is available for the next level of the tree as two control channels, each of which are half of the size of the control channel at the parent node.

The system bandwidth of a given number of sub-carrier resources may be divided to an integer multiple of the largest control channels. A given node of the tree, i.e., a set of sub-carriers, can be one control channel of the largest code block, of up to two control channels of the second largest code blocks or up to four control channels of the smallest code blocks.

Each control channel extends entirely over the first n OFDM symbols, which are available for the control channels. The control channels may be distributed to the sub-carriers over the system bandwidth to maximize the frequency diversity. For example, there are 4 distributed sets of sub-carrier resources allocated per each code-block. This is illustrated in FIG. 2.

In FIG. 1, three allocated nodes CB1, CB2, CB3 in different levels of the tree structure are shown. FIG. 2 shows the three allocated nodes CB1, CB2, CB3 mapped to the sub-carrier resources in a distributed manner. It should be noted that these mappings are only examples, and that the mapping in general should provide frequency diversity by scattering over the system bandwidth.

As each control channel has to be uniquely identified by a MAC ID, it can be combined to CRC (Cyclic Redundancy Code) by partly masking CRC bits with the MAC-ID. As the MAC ID is used for addressing both UE specific control channels and common control channels, it is reasonable to define the MAC ID in a compatible way. Thus, reception of any control channel is possible by filtering control channels with the respective MAC ID. Error detection is available from the MAC ID masked CRC. The length of the MAC ID is matched to the C-RNTI (Cell Radio Network Temporary Identifier) length.

A receiver, e.g. the UE, receives symbols of the Downlink Shared Control Channel part of the sub-frame prior to reception and processing of the symbols in the downlink and uplink Shared Data Channels. The receiver demodulates and decodes the sub-carriers of the OFDM symbols in which the receiver may search for a set of largest code blocks, e.g. CB1 of FIG. 1. As the Code Block is of known size and the system bandwidth is known, the receiver knows an integer multiple of sub-carrier positions to search for a CB1. The reception, whether correctly detected or not, may be recognized by Cyclic Redundancy Check detector filtered by a receiver specific c-RNTI identity. For every match of CRC, to which the c-RNTI of the UE does not match, the receiver knows that the next higher level of tree is masked and not available. For every non-matched CRC check, the UE will continue decoding code blocks (CB2) in the next higher level of the tree searching for a match in two child nodes of the parent node. Further on, for every non-matched CRC check, the UE will continue decoding code blocks (CB3) in the next higher level of the tree searching for a match in two child nodes of the parent node. The search continues until the UE has detected and correctly decoded all control channels, intended for its reception.

In addition to search signalling entries with its own receiver specific c-RNTI, the UE may have to search for common signalling entries by common identifiers.

The search in the tree may happen in any other order than from the lowest level node towards the higher level nodes. Depending on the applied coding scheme, the receiver may process the nodes from the highest level of nodes to the lower level of nodes. Further on, the receiver may process the nodes in other arbitrary (or systematic) order based on some measures e.g. SINR (Signal Interference and Noise Ratio) quality of the candidate code block(s).

In the following it is assumed that only a single size of a node (i.e. control channel) at the highest level of the tree structure (level 3 in FIG. 1) is defined for a given bandwidth in a cell. The highest level node is referred to as "control channel element". Aggregation of multiple control channel elements can be used to get larger payloads and/or lower coding rate.

However, the aggregation of the control channel elements may require a large number of decoding attempts from all the UEs that are listening for a possible allocation. An example of a control channel aggregation is shown in FIG. 3.

From FIG. 3 it can be seen that an aggregation of even a relative low number of control channel elements will result in a rather high number of decoding attempts for the UEs listening for resource allocations, and each UE will listen for downlink allocations as well as uplink allocations. In the example in FIG. 3, there are 6 control channel elements, while the aggregation using a tree structure as shown in FIG. 1 results in 10 potential control channel candidates. This is suboptimal regarding UE complexity, as a UE will have to decode the full amount of control channel candidates even if some of them are not scheduled.

In the following an embodiment will be described in greater detail.

FIG. 4 shows a kind of flat tree structure arising from FIG. 3. FIG. 4 illustrates potential control channel candidates for different aggregation possibilities (both the white and grey areas). As can be seen from FIG. 4, there is a total of 24 control channel elements (CCEs), which by default triggers 45 decoding attempts per link direction (i.e. downlink/uplink) allocation. In other words, in aggregation level 1 the 24 control channel elements each may form a control channel. In aggregation level 2, two control channel elements may be aggregated to form a control channel, in aggregation level 4, four control channel elements may be aggregated to form a control channel, and in aggregation level 8, eight control channel elements may be aggregated to form a control channel.

According to an embodiment, the control channel structure shown by the white and grey areas in FIG. 4 is put under limitations, such that only the white aggregated control channel candidates are available for scheduling. With this limitation, the number of decoding attempts is reduced to 15 (the grey areas are not decoded in search for a control channel candidate), which corresponds to a reduction by a factor of 3. In other words, there are four control channel candidates in aggregation level 1, four control channel candidates in aggregation level 2, four control channel candidates in aggregation level 4, and three control channel candidates in aggregation level 8.

With the above limitation put on the tree structure, scheduling flexibility is not reduced that much, based on the following arguments:

If there is a lot of user equipments close to an eNB scheduling the control channels, which user equipments require only aggregation level 1, the aggregated level 2

5

elements with reduced power can be used to have more users due to the possibility of doing power balancing; in the example shown in FIG. 4, 9 favourable conditioned users can be scheduled using this approach. In other words, four control channels in aggregation level 1, two control channels in aggregation level 2, two control channels in aggregation level 4, and one control channel in aggregation level 8 can be scheduled.

If a plurality of scheduled users is present at a cell edge (aggregation level 8), additional users cannot be scheduled anyway due to limited number of available control channel elements.

As the difference between aggregation layers is a factor of 2 and when using power balancing, to some extent there is flexibility to trade aggregation and power between each other.

It should be noted that although the above description is given for an allocation tree for single link direction, the method is also valid for the case where two trees, for uplink and downlink, respectively, are present.

Further, it should be noted that the number of possible control channels at each layer is not important.

According to an embodiment, using an allocation rule, usage of the smallest control channel on all control channel elements is prohibited, while at the same time the smaller control channels are allowed to be combined to aggregated control channels with better coverage.

With the above approach, the number of decoding attempts that is needed by each UE can be reduced. The limitation of the tree is possible due to the frequency diversity applied for all control channel elements, such that each CCE experiences same or similar channel conditions.

FIG. 5 shows a schematic block diagram illustrating a user equipment 10 and a network device 20, such as an eNB, according to an embodiment.

The user equipment 10 includes a receiving/transmitting section 11 and a decoding section 12. The receiving/transmitting section 11 receives symbols from the network device 20, which includes a receiving transmitting section 21 transmitting the symbols and an allocation section 22.

The allocation section 22 allocates control channels represented by nodes of a tree structure, each of the control channels having at least one control channel element carrying information for a respective identifier used to detect a control channel of the control channels, wherein the allocation is performed by limiting allocation of highest level control channels of the control channels, the highest level control channels being represented by nodes of the tree structure at a highest level of the tree structure. For example, in FIG. 1 the highest level is shown by level 3. Referring to FIG. 4, the highest level is represented by aggregation level 1.

The allocation section 22 may increase allocation of lower level control channels of the control channels, the lower level control channels being represented by nodes of the tree structure at lower levels of the tree structure. For example, in FIG. 1 the lower levels are shown by levels 2 and 1. Referring to FIG. 4, the lower levels are represented by aggregation levels 2, 4 and 8.

The receiving/transmitting section 21 may transmit the allocated control channels as symbols to user equipments including the user equipment 10, by distributing the allocated control channels to sub-carriers over a system bandwidth.

The higher level control channels may be combined to the lower level control channels. In other words, smaller control channels are allowed to be combined to aggregated control channels with better coverage.

6

The allocation section 22 may increase allocation more the lower the level of the tree structure.

The searching section 12 of the user equipment 10 searches for a control channel by decoding control channels represented by nodes of a tree structure, by using an identifier such as an MAC ID, CRC or c-RNTI, each of the control channels having at least one control channel element carrying information for a respective identifier used to detect a control channel of the control channels, wherein the searching section 12 limits the searching for highest level control channels of the control channels, the highest level control channels being represented by nodes of the tree structure at a highest level of the tree structure.

The searching section 12 may increase the searching for lower level control channels of the control channels, the lower level control channels being represented by nodes of the tree structure at lower levels of the tree structure.

The receiving/transmitting section 11 may receive the control channels as symbols from the network device 20.

The searching section 11 may begin the searching with lowest level control channels represented by nodes of the tree structure at a lowest level of the tree structure. For example, in FIG. 1 the lowest level is shown by level 1. Referring to FIG. 4, the lowest level is represented by aggregation level 8.

It is to be noted that the network device 20 and user equipment 10 shown in FIG. 5 may have further functionality for working e.g. as eNodeB and UE. Here the functions of the network device and user equipment relevant for understanding the principles are described using functional blocks as shown in FIG. 5. The arrangement of the functional blocks of the network device and user equipment is not construed to limit the invention, and the functions may be performed by one block or further split into sub-blocks.

According to an embodiment, on a transmitting side, control channels represented by nodes of a tree structure are allocated, each of the control channels having at least one control channel element carrying information for a respective identifier used to detect a control channel of the control channels. The allocation is performed by limiting allocation of highest level control channels of the control channels, the highest level control channels being represented by nodes of the tree structure at a highest level of the tree structure. On a receiving side, a control channel is searched for by decoding the allocated control channels, wherein the searching is limited for the highest level control channels.

The system also includes permanent or removable storage, such as magnetic and optical discs, RAM, ROM, etc. on which the process and data structures of the present invention can be stored and distributed. The processes can also be distributed via, for example, downloading over a network such as the Internet. The system can output the results to a display device, printer, readily accessible memory or another computer on a network.

It is to be understood that the above description is illustrative of the invention and is not to be construed as limiting the invention. Various modifications and applications may occur to those skilled in the art without departing from the scope of the invention as defined by the appended claims which may include the phrase “at least one of A, B and C” as an alternative expression that means one or more of A, B and C may be used, contrary to the holding in *Superguide v. DIRECTV*, 358 F3d 870, 69 USPQ2d 1865 (Fed. Cir. 2004).

The invention claimed is:

1. A method of operating a user equipment, the method comprising:
 - receiving a wireless signal at the user equipment, the wireless signal comprising a control channel for the user

7

equipment, the control channel being in at least one control channel element (CCE), the control channel comprising an indication of an uplink communication resource useable by the user equipment for uplink communication;

searching for the control channel in the at least one CCE from a plurality of candidate CCEs, the plurality of candidate CCEs being in a plurality of aggregation levels, each of the plurality of aggregation levels comprising a respective limited number of candidate control channels, and the searching includes searching at least one of the respective limited number of candidate control channels in at least one of the plurality of aggregation levels; and

transmitting an uplink data signal according to the uplink communication resource, the indication of the uplink communication resource decoded from the control channel of the wireless signal according to the plurality of candidate CCEs using an identifier associated with the user equipment.

2. The method of claim 1, wherein at a first aggregation level the control channel is in one CCE and wherein at a second aggregation level the control channel is in two consecutive CCEs.

3. The method of claim 2, wherein at a third aggregation level the control channel is in four consecutive CCEs and wherein at a fourth aggregation level the control channel is in eight consecutive CCEs.

4. The method of claim 1, wherein the searching further comprises:

decoding the plurality of candidate CCEs using the identifier associated with the user equipment to determine the uplink communication resource.

5. A user equipment comprising:

a receiver operable to receive a wireless signal at the user equipment, the wireless signal comprising a control channel for the user equipment, the control channel being in at least one control channel element (CCE), wherein the control channel comprises an indication of an uplink communication resource useable by the user equipment for uplink communication;

a processor operable to search for the control channel in the at least one CCE from a plurality of candidate CCEs, the plurality of candidate CCEs being in a plurality of aggregation levels, each of the plurality of aggregation levels comprising a respective limited number of candidate control channels, and the searching includes searching at least one of the respective limited number of candidate control channels in at least one of the plurality of aggregation levels; and

a transmitter operable to transmit an uplink data signal according to the uplink communication resource, the indication of the uplink communication resource decoded from the control channel of the wireless signal

8

according to the plurality of candidate CCEs using an identifier associated with the user equipment.

6. The user equipment of claim 5, wherein at a first aggregation level the control channel is in one CCE and wherein at a second aggregation level the control channel is in two consecutive CCEs.

7. The user equipment of claim 6, wherein at a third aggregation level the control channel is in four consecutive CCEs and wherein at a fourth aggregation level the control channel is in eight consecutive CCEs.

8. The user equipment of claim 5, wherein the processor is further operable

to decode the plurality of candidate CCEs using the identifier associated with the user equipment to determine the uplink communication resource.

9. A non-transitory computer readable storage medium storing a set of instructions for execution by a user equipment, the set of instructions comprising:

a receiving code segment for receiving a wireless signal at the user equipment, the wireless signal comprising a control channel for the user equipment, the control channel being in at least one control channel element (CCE), the control channel comprising an indication of an uplink communication resource useable by the user equipment for uplink communication;

a searching code segment for searching for the control channel in the at least one CCE from a plurality of candidate CCEs, the plurality of candidate CCEs being in a plurality of aggregation levels, each of the plurality of aggregation levels comprising a respective limited number of candidate control channels, and the searching includes searching at least one of the respective limited number of candidate control channels in at least one of the plurality of aggregation levels; and

a transmitting code segment for transmitting an uplink data signal according to the uplink communication resource, the indication of the uplink communication resource decoded from the control channel of the wireless signal according to the plurality of candidate CCEs using an identifier associated with the user equipment.

10. The non-transitory computer readable medium of claim 9, wherein at a first aggregation level the control channel is in one CCE and wherein at a second aggregation level the control channel is in two consecutive CCEs.

11. The non-transitory computer readable medium of claim 10, wherein at a third aggregation level the control channel is in four consecutive CCEs and wherein at a fourth aggregation level the control channel is in eight consecutive CCEs.

12. The non-transitory computer readable medium of claim 9, wherein the searching code segment includes instructions for decoding the plurality of candidate CCEs using the identifier associated with the user equipment to determine the uplink communication resource.

* * * * *