



US009271249B2

(12) **United States Patent**
Davydov et al.

(10) **Patent No.:** **US 9,271,249 B2**
(45) **Date of Patent:** **Feb. 23, 2016**

(54) **ASSOCIATION BIASING FOR A HETEROGENEOUS NETWORK (HETNET)**

(75) Inventors: **Alexei Davydov**, Nizhny Novgorod (RU); **Alexander Maltsev**, Nizhny Novgorod (RU); **Gregory Morozov**, Nizhny Novgorod (RU); **Ilya Bolotin**, Nizhny Novgorod (RU)

(73) Assignee: **INTEL CORPORATION**, Santa Clara, CA (US)

(*) Notice: Subject to any disclaimer, the term of this patent is extended or adjusted under 35 U.S.C. 154(b) by 100 days.

(21) Appl. No.: **13/994,119**

(22) PCT Filed: **Aug. 3, 2012**

(86) PCT No.: **PCT/US2012/049601**

§ 371 (c)(1),
(2), (4) Date: **Mar. 14, 2014**

(87) PCT Pub. No.: **WO2013/025379**

PCT Pub. Date: **Feb. 21, 2013**

(65) **Prior Publication Data**

US 2014/0185523 A1 Jul. 3, 2014

Related U.S. Application Data

(60) Provisional application No. 61/523,080, filed on Aug. 12, 2011.

(30) **Foreign Application Priority Data**

Dec. 28, 2011 (RU) 2011154105

(51) **Int. Cl.**

H04W 48/18 (2009.01)
H04W 56/00 (2009.01)
H04W 52/34 (2009.01)
H04L 5/00 (2006.01)
H04W 24/02 (2009.01)
H04L 1/00 (2006.01)
H04W 52/14 (2009.01)
H04W 52/24 (2009.01)

(52) **U.S. Cl.**
CPC **H04W 56/0045** (2013.01); **H04L 1/0003** (2013.01); **H04L 1/0026** (2013.01);

(Continued)

(58) **Field of Classification Search**
None
See application file for complete search history.

(56) **References Cited**

U.S. PATENT DOCUMENTS

2009/0280819 A1 11/2009 Brisebois et al.
2010/0093354 A1 4/2010 Agashe et al.

(Continued)

FOREIGN PATENT DOCUMENTS

WO 2011/027091 A1 3/2011
WO 2011/057717 A1 5/2011
WO 2013/025379 A1 2/2013

OTHER PUBLICATIONS

International Preliminary Report on Patentability with Written Opinion received for PCT Patent Application No. PCT/US2012/049601, mailed on Feb. 27, 2014, 6 pages.

(Continued)

Primary Examiner — Duc Duong

(74) *Attorney, Agent, or Firm* — Thorpe North & Western LLP

(57) **ABSTRACT**

A method for association biasing at a mobile device in a heterogeneous network (HetNet) is disclosed. The method can include the mobile device receiving coordination set information from a macro node in the HetNet. The coordination set information can include at least one low power node (LPN) identifier of at least one LPN. The mobile device can receive a request from the macro node to apply a specified reference signal (RS) biasing. The mobile device can apply the specified RS biasing to an LPN RS measurement derived from a LPN RS received from an LPN having an LPN identifier in the received coordination set information. The mobile device can associate the mobile device with the LPN when the LPN RS measurement with the specified RS biasing exceeds an association threshold.

20 Claims, 8 Drawing Sheets

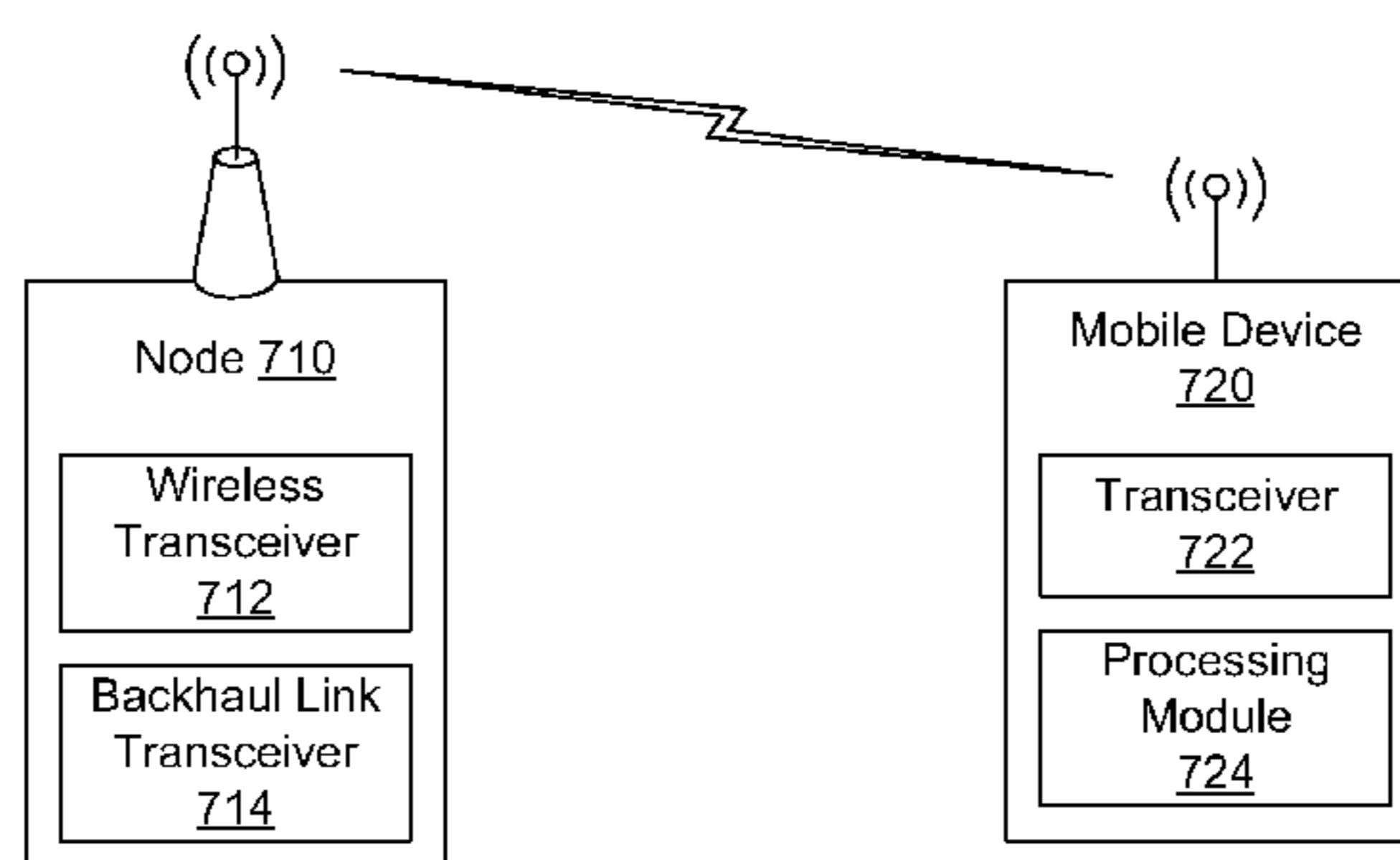

(52) **U.S. Cl.**
 CPC *H04L 5/001* (2013.01); *H04L 5/0032*
 (2013.01); *H04L 5/0057* (2013.01); *H04L*
5/0073 (2013.01); *H04L 5/0091* (2013.01);
H04W 24/02 (2013.01); *H04W 52/34*
 (2013.01); *H04W 52/146* (2013.01); *H04W*
52/241 (2013.01)

(56) **References Cited**

U.S. PATENT DOCUMENTS

2010/0267386 A1 10/2010 Lim et al.
 2011/0194527 A1* 8/2011 Lin et al. 370/330
 2013/0039199 A1* 2/2013 Liao et al. 370/252

2013/0039203 A1* 2/2013 Fong et al. 370/252
 2013/0223235 A1* 8/2013 Hu et al. 370/242
 2013/0303167 A1* 11/2013 Zhu et al. 455/436
 2014/0079026 A1* 3/2014 Dimou et al. 370/332
 2014/0086203 A1* 3/2014 Furuskar et al. 370/330

OTHER PUBLICATIONS

Qualcomm Incorporated, "Macro-pico performance with traffic model with and without CRE", 3GPP TSG-RAN WG1 #62bis, R1-105588, Oct. 11-15, 2010, 14 pages.
 International Search Report and Written Opinion received for PCT application No. PCT/US2012/049601, mailed on Jan. 22, 2013, 9 pages.

* cited by examiner

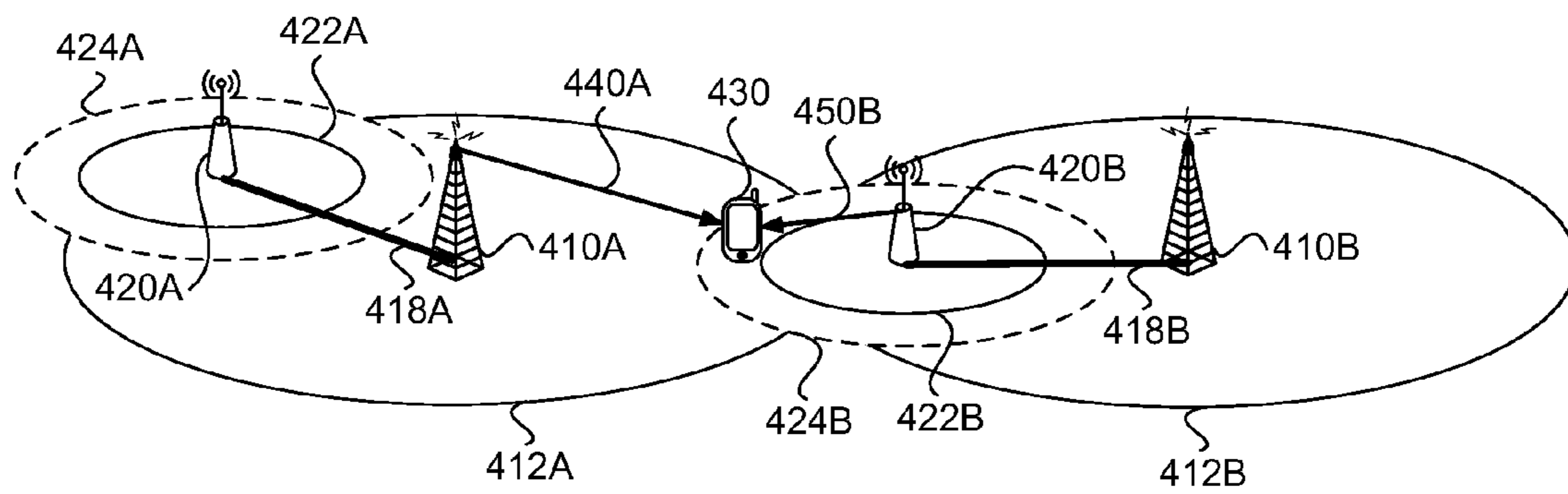

FIG. 1

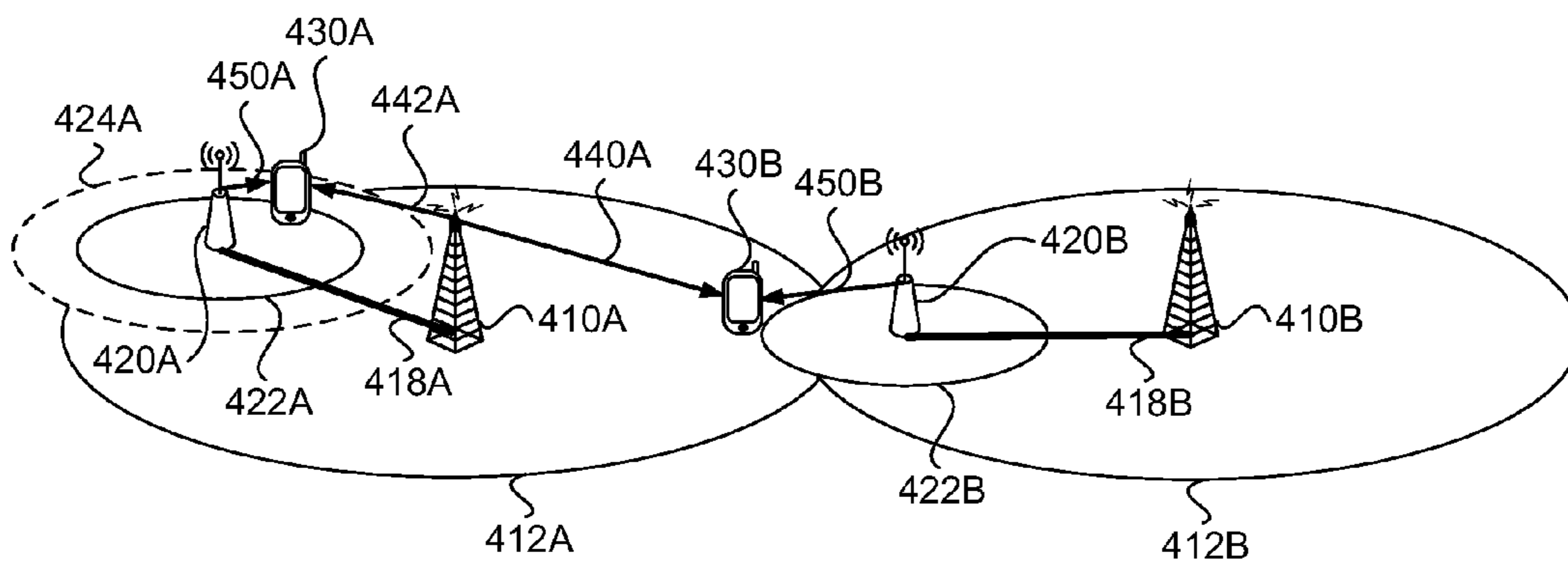

FIG. 2

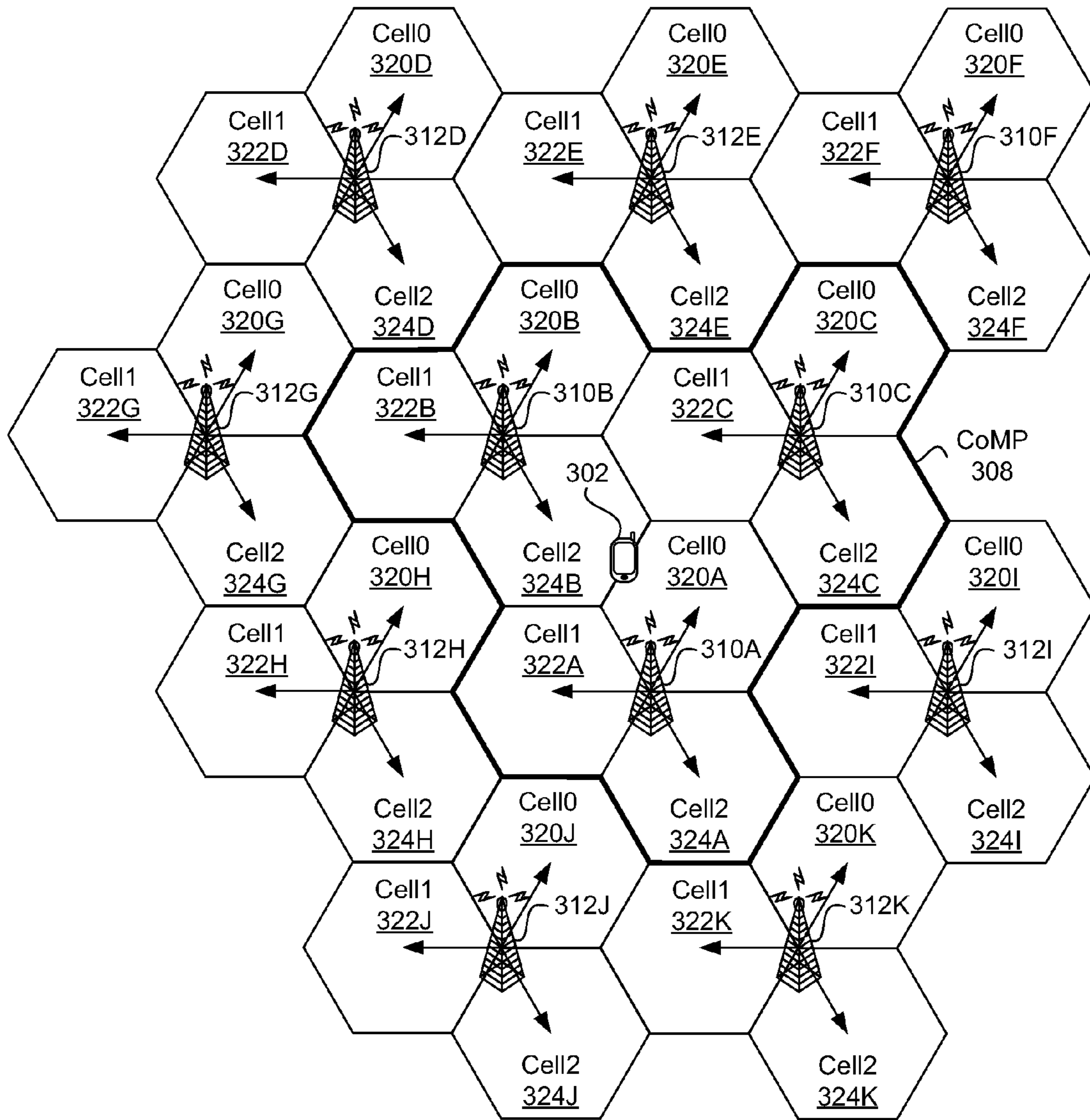

FIG. 4A

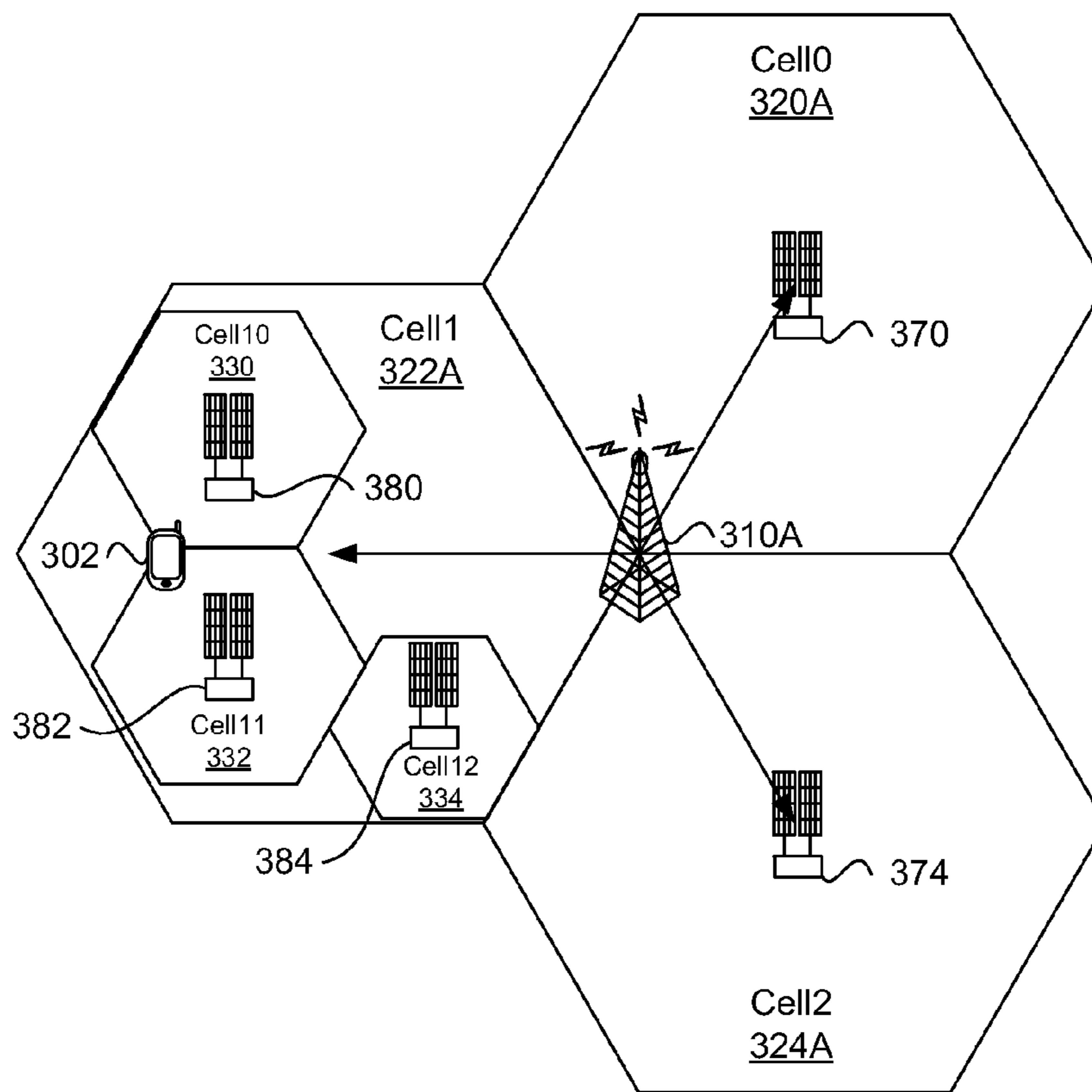

FIG. 4B

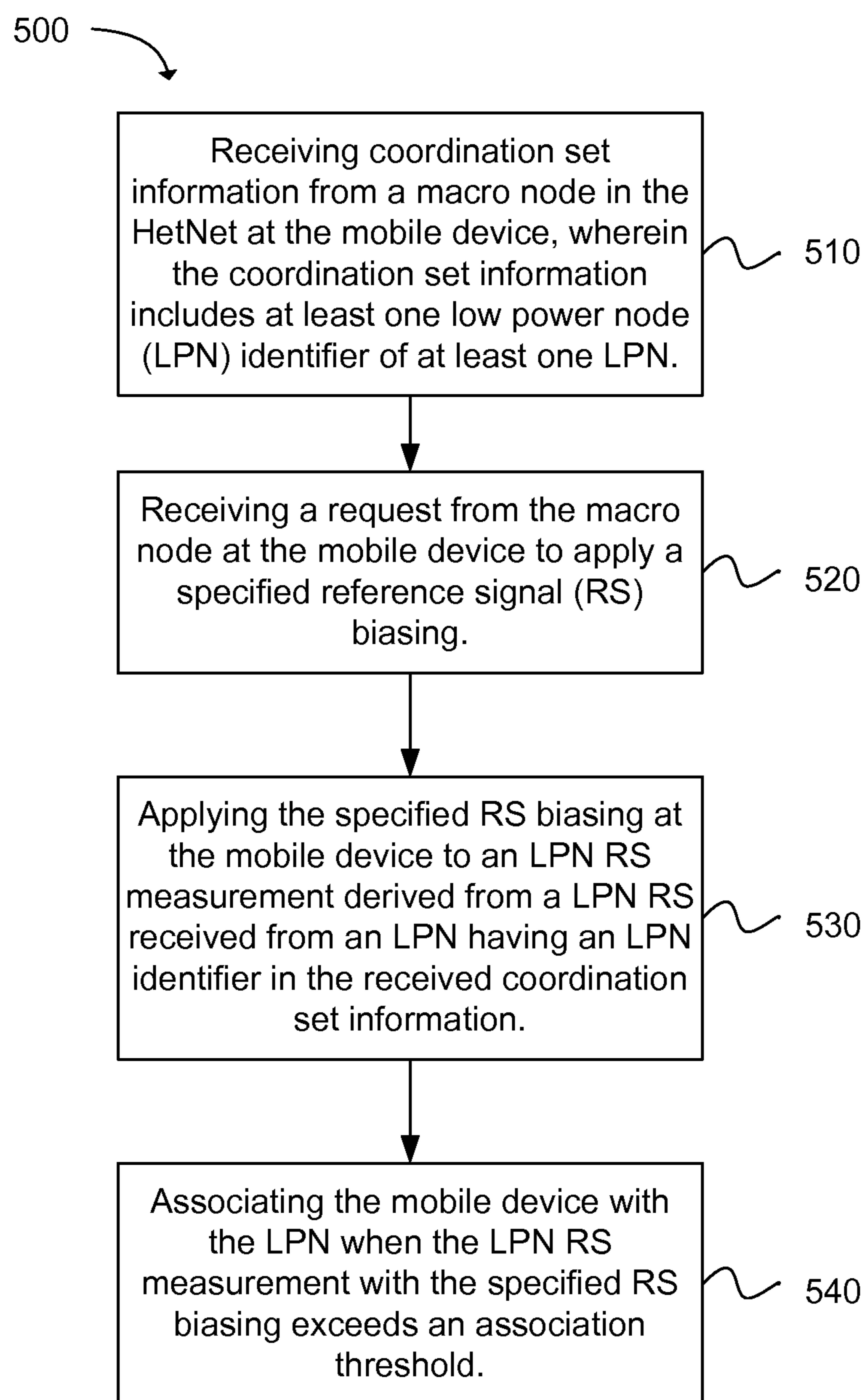

FIG. 5

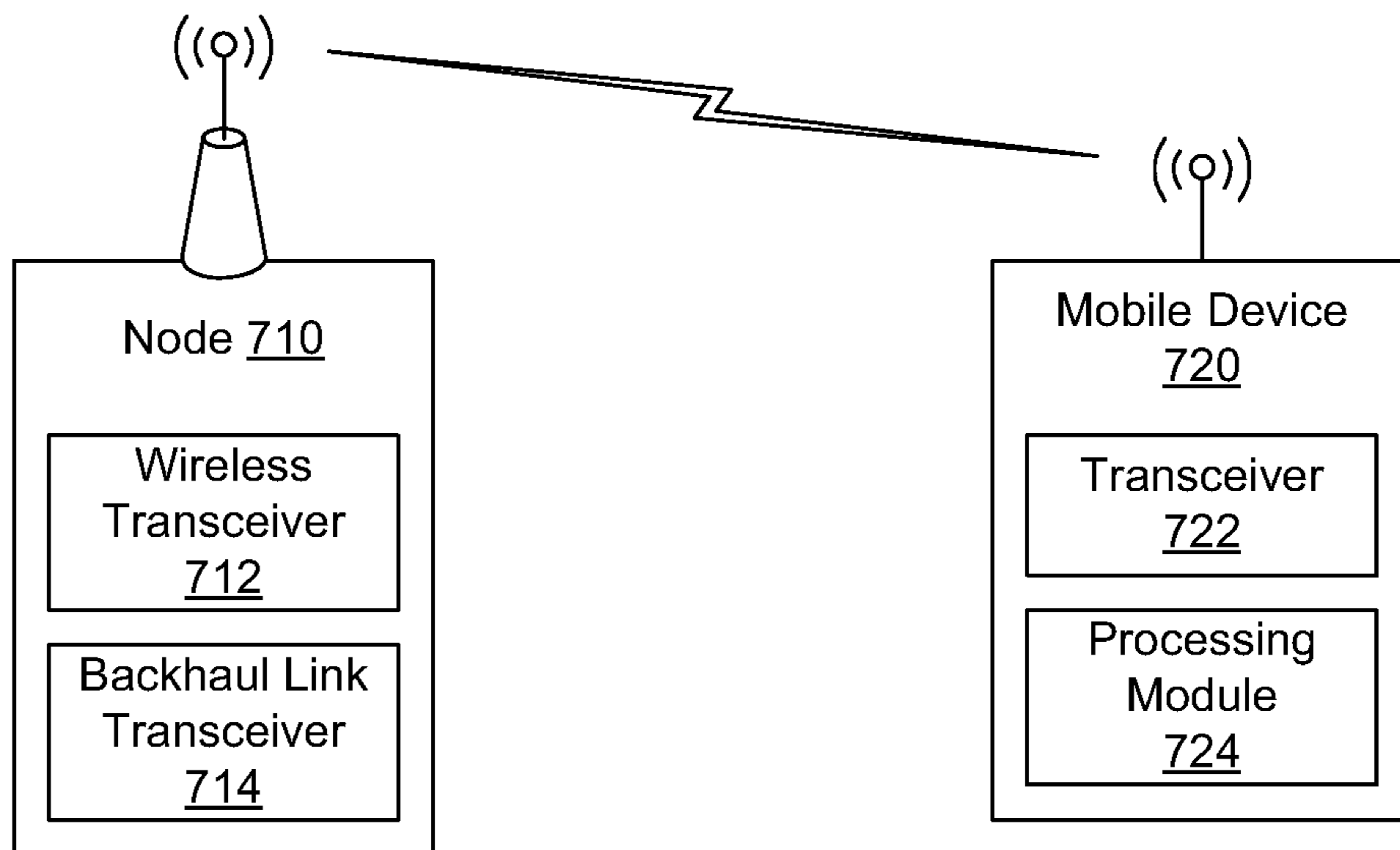

FIG. 6

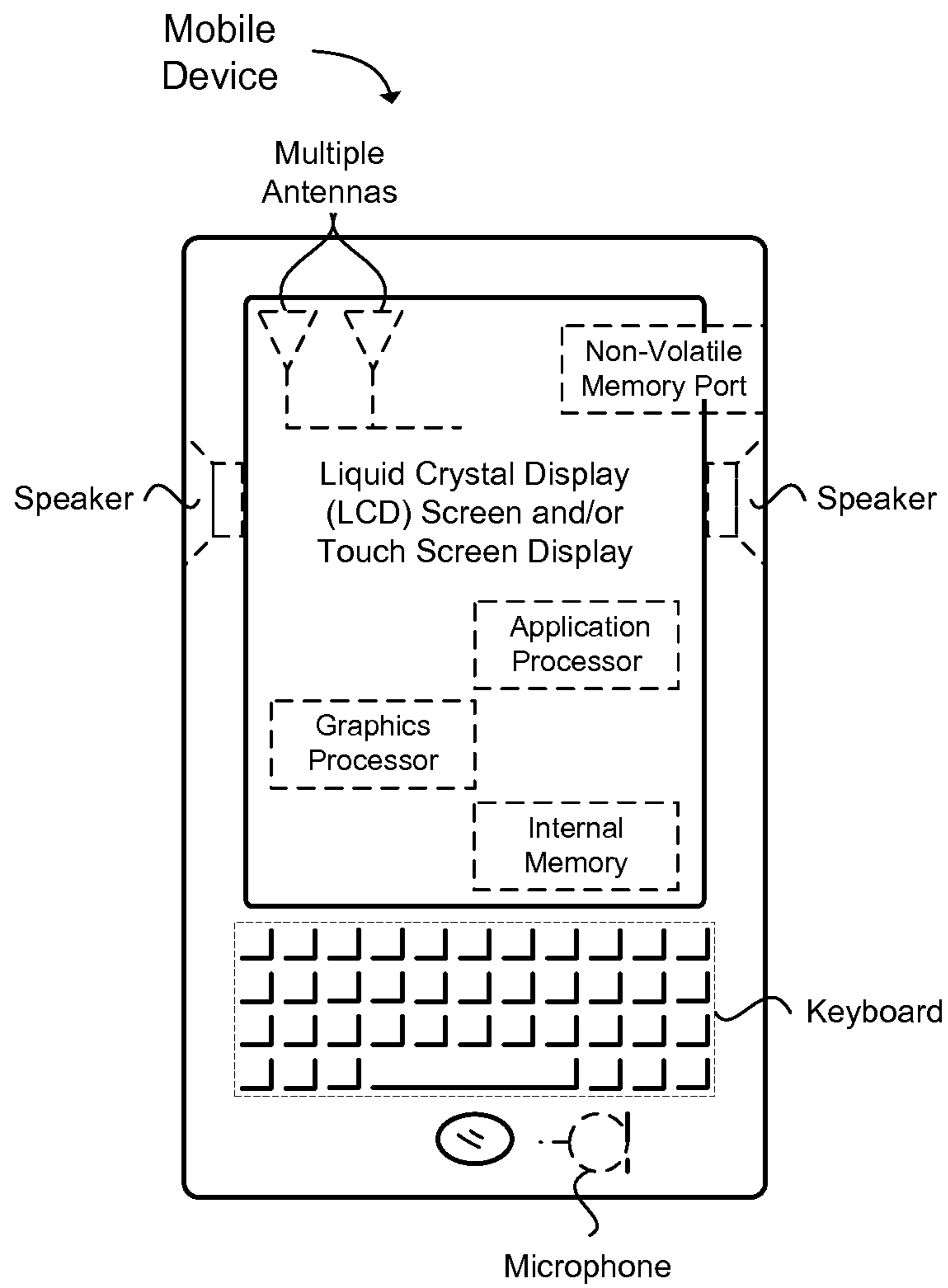

FIG. 7

ASSOCIATION BIASING FOR A HETEROGENEOUS NETWORK (HETNET)

BACKGROUND

Wireless mobile communication technology uses various standards and protocols to transmit data between a transmission station and a wireless mobile device. Some wireless devices communicate using orthogonal frequency-division multiplexing (OFDM) combined with a desired digital modulation scheme via a physical layer. Standards and protocols that use OFDM include the third generation partnership project (3GPP) long term evolution (LTE), the Institute of Electrical and Electronics Engineers (IEEE) 802.16 standard (e.g., 802.16e, 802.16m), which is commonly known to industry groups as WiMAX (Worldwide interoperability for Microwave Access), and the IEEE 802.11 standard, which is commonly known to industry groups as WiFi.

In 3GPP radio access network (RAN) LTE systems, the transmission station can be a combination of Evolved Universal Terrestrial Radio Access Network (E-UTRAN) Node Bs (also commonly denoted as evolved Node Bs, enhanced Node Bs, eNodeBs, or eNBs) and Radio Network Controllers (RNCs), which communicates with the wireless mobile device, known as a user equipment (UE). A downlink (DL) transmission can be a communication from the transmission station (or eNodeB) to the wireless mobile device (or UE), and an uplink (UL) transmission can be a communication from the wireless mobile device to the transmission station.

In homogeneous networks, the transmission station, also called macro nodes, can provide basic wireless coverage to mobile devices in a cell. Heterogeneous networks (HetNets) are used to handle the increased traffic loads on the macro nodes due to increased usage and functionality of mobile devices. HetNets can include a layer of planned high power macro nodes (or macro-eNBs) overlaid with layers of lower power nodes (micro-eNBs, pico-eNBs, femto-eNBs, or home eNBs [HeNBs]) that can be deployed in a less well planned or even entirely uncoordinated manner within the coverage area of the macro nodes. The macro nodes can be used for basic coverage, and the low power nodes can be used to fill coverage holes, to improve capacity in hot-zones or at the boundaries between the macro nodes' coverage areas, and improve indoor coverage where building structures impede signal transmission. Inter-cell interference coordination (ICIC) or enhanced ICIC (eICIC) may be used for resource coordination to reduce interference between the transmission stations (or nodes), such as macro nodes and low power nodes. In ICIC an interfering node (or an aggressor node) may give up use of some resources in order to enable control and data transmissions between a victim node or victim mobile device.

The transmission stations, such as the macro nodes and/or lower power nodes (LPN), can also be grouped together with other transmission stations in a Coordinated MultiPoint (CoMP) system where transmission stations from multiple cells can transmit signals to the mobile device and receive signals from the mobile device.

BRIEF DESCRIPTION OF THE DRAWINGS

Features and advantages of the disclosure will be apparent from the detailed description which follows, taken in conjunction with the accompanying drawings, which together illustrate, by way of example, features of the disclosure; and, wherein:

FIG. 1 illustrates a block diagram of a heterogeneous network (HetNet) including a plurality of coordination sets each

with a macro node and a low power node (LPN) using range expansion in accordance with an example;

FIG. 2 illustrates a block diagram of a heterogeneous network (HetNet) including a plurality of coordination sets each with a macro node and a low power node (LPN) and applying range expansion to the LPN in the same coordination set as the macro node and in accordance with an example;

FIG. 3 illustrates a block diagram of a heterogeneous network (HetNet) including a plurality of coordination sets each with a macro node and a low power node (LPN) and applying range expansion in an association between the macro node and the LPN in the same coordination set in accordance with an example;

FIG. 4A illustrates a block diagram of an inter-site coordinated multipoint (CoMP) system with non-cooperating transmitting stations in accordance with an example;

FIG. 4B illustrates a block diagram of an intra-site coordinated multipoint (CoMP) system with a low power node (LPN) in accordance with an example;

FIG. 5 depicts a flow chart of a method for association biasing at a mobile device in a heterogeneous network (HetNet) in accordance with an example;

FIG. 6 illustrates a block diagram of a macro node and a mobile device in accordance with an example; and

FIG. 7 illustrates a diagram of a mobile device in accordance with an example.

Reference will now be made to the exemplary embodiments illustrated, and specific language will be used herein to describe the same. It will nevertheless be understood that no limitation of the scope of the invention is thereby intended.

DETAILED DESCRIPTION

Before the present invention is disclosed and described, it is to be understood that this invention is not limited to the particular structures, process steps, or materials disclosed herein, but is extended to equivalents thereof as would be recognized by those ordinarily skilled in the relevant arts. It should also be understood that terminology employed herein is used for the purpose of describing particular examples only and is not intended to be limiting. The same reference numerals in different drawings represent the same element. Numbers provided in flow charts and processes are provided for clarity in illustrating steps and operations and do not necessarily indicate a particular order or sequence.

Example Embodiments

An initial overview of technology embodiments is provided below and then specific technology embodiments are described in further detail later. This initial summary is intended to aid readers in understanding the technology more quickly but is not intended to identify key features or essential features of the technology nor is it intended to limit the scope of the claimed subject matter.

A heterogeneous network (HetNet) can include a macro node and at least one low power node (LPN). The macro node can be grouped with the at least one LPN in a coordination set. The macro node can provide inter-cell interference coordination (ICIC), enhanced ICIC (eICIC), or coordinated multipoint (CoMP) transmission for the LPNs (or other macro nodes) in the coordination set. The macro node may not provide ICIC, eICIC, or CoMP for the LPNs or other macro nodes outside the coordination set. A mobile device in communication with the macro node (or within a coverage area of the macro node) can receive coordination set information from the macro node. The coordination set information can

include identifiers of LPNs in the coordination set, including at least one LPN identifier of the at least one LPN.

The macro node can request that mobile devices in communication with the macro node apply a specified reference signal (RS) biasing. The macro node may request the application of the specified RS biasing when the macro node is experiencing a heavy traffic load in an attempt to offload traffic to the LPNs within the HetNet. The mobile device may receive reference signals, such as cell specific reference signals (CRS) or channel state information reference signals (CSI-RS), from LPN located nearby the mobile device. The mobile device can measure a power or quality of a macro node's RS and can measure a power or quality of LPNs' RS. A RS measurement can include a reference signal received power (RSRP), a reference signal received quality (RSRQ), or a combination of RSRP and RSRQ. The mobile device can compare the macro node's RS measurements with the LPNs' RS measurements. The mobile device may associate with the macro node or the LPN with a higher power quality RS measurement. The mobile device can apply the specified RS biasing (or RS power offset or RS quality offset) to either effectively lower the macro node's RS measurements or effectively raise the LPN's RS measurements, so that some LPNs with a lower power or lesser quality measurement prior to the biasing can appear to have a higher power or better quality measurement than the macro node after the biasing. With the application of specified RS biasing, some mobile devices may be handed-over or offloaded from the macro node to the LPNs that appeared to have a higher power or better quality measurement than the macro node. As a result of the specified RS biasing, the LPN's range expands and more mobile devices re-associate with LPN instead of maintaining the association with the macro node. Also as a result of the specified RS biasing, the macro node can reduce the mobile devices in direct communication with the macro node and offload mobile devices to the LPNs. The mobile device may apply the specified RS biasing to an LPN RS measurement when an LPN identifier representing the LPN is within the received coordination set information. The mobile device can associate with the LPN when the LPN RS measurement with the specified RS biasing exceeds an association threshold. ICIC, eICIC, or CoMP may be applied to the nodes within the coordination set to manage the low power conditions of the LPN, enhance the signal of the LPN, and/or reduce the interference from other nodes and devices. The mobile device may ignore the specified RS biasing to an LPN RS measurement when an LPN identifier for the LPN is not within the received coordination set information. If the LPN is not with the same coordination set as the macro node, ICIC, eICIC, or CoMP may be less effective to manage the low power conditions of the LPN, enhance the signal of the LPN, and/or reduce interference from other nodes and devices.

The following provides additional details of the examples. FIG. 1 illustrates a heterogeneous network (HetNet) with a first high power macro node **410A** (or macro-eNB) with a first backhaul communication link **418A** with a first lower power node **420A** (micro-eNBs, pico-eNBs, femto-eNBs, home eNBs [HeNBs], remote radio head [RRH], or relay node). The HetNet can include a second high power macro node **410B** (or macro-eNB) with a second backhaul communication link **418B** with a second lower power node **420B** (micro-eNBs, pico-eNBs, femto-eNBs, home eNBs [HeNBs], remote radio head [RRH], or relay node). The backhaul communication link can be a wired, wireless, or optical fiber connection. The backhaul communication link may use X2 signaling. The backhaul communication link can be used to apply interference mitigation or signal coordination between

the macro node and the LPNs in a coordination set. HetNets can be used to optimize performance particularly for unequal user or traffic distribution and improve spectral efficiency per unit area of a cell. HetNets can also achieve significantly improved overall capacity and cell-edge performance. Enhanced inter-cell interference coordination (eICIC) can be used to coordinate resources between the macro node and the low power node (LPN) in the HetNet and reduce interference. Generally, eICIC can allow interfering nodes to coordinate on transmission powers and/or spatial beams with each other in order to enable control and data transmissions to their corresponding mobile devices. Enhanced biasing for HetNet systems can be used with interference mitigation techniques, such as CoMP or eICIC.

The HetNet (and homogeneous network) can include regular (planned) placement of macro nodes **410A** and **410B** that can typically transmit at high power level, for example, approximately 5 watts (W) to 40 W, to cover the macro cell **412A** and **412B**. The HetNet can be overlaid with low power nodes (LPNs) **420A** and **420B**, which may transmit at substantially lower power levels, such as approximately 100 milliwatts (mW) to 2 W. In an example, an available transmission power of the macro node may be at least ten times an available transmission power of the low power node. A LPN can be used in hot spots or hot-zones, referring to areas with a high wireless traffic load or high volume of actively transmitting wireless devices. A LPN can be used in a microcell, a picocell, a femtocell, and/or home network. The microcell can be located in a mall, a hotel, or a transportation hub. The picocell can be located in small to medium size structures such as offices, shopping malls, train stations, stock exchanges, or in-aircraft. The femtocell can be located in small structures such as a home or a small business.

In an example, a microcell can have a range less than two kilometers (km) and a picocell can have a range within 200 meters (m). In another example, a femtocell can support up to 16 active mobile devices and can have a range within 50 m. In an example, a LPN may have a power less than 24 decibels relative to 1 milliwatt (dBm) for 1 antenna, less than 21 dBm for 2 antennas, and less than 18 dBm for 4 antennas. The decibel (dB) is a logarithmic unit that indicates the ratio of a physical quantity (usually power or intensity) relative to a specified or implied reference level. A ratio in decibels is ten times the logarithm to base 10 of the ratio of two power quantities. The power relative to 1 milliwatt (mW) can be represented by dBm (dB(mW)). In another example, a HeNB may have a power less than 20 dBm for 1 antenna, less than 17 dBm for 2 antennas, and less than 14 dBm for 4 antennas. The HeNB can perform many of the functions of the eNodeB, but the HeNB can be optimized or designed for use in a home or an office. A RRH may be used in a centralized, cooperative, or cloud radio access network (C-RAN), where the transmission station (or eNodeB) functionality can be subdivided between a base band unit (BBU) processing pool and a remote radio unit (RRU) or a remote radio head (RRH) with optical fiber connecting the BBU to the RRU. A relay node may be used to decode and forward or repeat the signaling of a macro node.

A LPN **420A** or **420B** can have a standard cell range **422A** or **422B** (or inner cell range) or a cell range expansion **424A** or **424B** (or cell range extension, edge cell range, or cell-edge range). Due to the closer proximity of the mobile device to the LPN, the mobile device within the standard cell range of the LPN may experience less interference from the macro node and other sources than a mobile device within the cell range extension but outside the standard cell range. The standard cell coverage or range (or center cell range) can represent an area in space (a geographic area) near the transmitting station

where the transmission power and signal can be strong and a co-channel interference can be minimal. A cell range expansion (CRE) can be area near to the boundary of the cell where the transmission power and signal is weaker than a signal in the standard cell and the co-channel interference can be more significant. In an example, the first macro node **410A** can generate a cell range expansion in the first LPN **420A** and the second LPN node by requesting that mobile devices within the first macro node's coverage area perform biasing, such as RS biasing.

The cell range expansion of LPNs can be due to RS biasing requested by the macro nodes. RS biasing can apply an offset to the RS measurements allowing a LPN with a signal strength weaker than the macro node to associate with the mobile device. In an example, the RS biasing can have a range greater than 0 dB to about 6 dB. In another example, the RS biasing can have a range greater than 0 dB to about 16 dB.

Association (or handover) biasing can be an effective means to achieve the load balancing in non-uniform heterogeneous network deployments. The load balancing can be provided by coverage (or range) expansion at LPNs (low transmission power nodes). The range expansion can be virtually achieved by biasing of the mobile device association metric for LPNs by some value which may be signaled from the macro node to the mobile device via higher layers, such as radio resource control (RRC) signaling. The mobile device association metric can include a reference signal received power (RSRP) or a reference signal received quality (RSRQ). The load balancing can introduce severe interference conditions for mobile devices located in the range expansion zone. In order to provide reasonable throughput performance for such mobile devices, interference mitigation schemes, such as DL eICIC or CoMP, can be applied at the macro node (an overlay high transmission power node or aggressor node).

The association can refer to the mobile device's direct wireless communication with a node, either a macro node or LPN. A re-association can include transferring a mobile device's direct wireless communication from one node to another node. The both nodes in the re-association may be within a coordination set or the nodes in the re-association may be in different coordination sets. A handover can refer to a transfer of the mobile device's direct wireless communication from a first node in a first coordination set to a second node in a second coordination set.

In an example, association biasing may not account for interference mitigation scheme parameters, such as a coordination set. In particular, association biasing applied at the mobile device for LPNs regardless of the coordination set that the LPNs belong to can reduce the effectiveness of the interference mitigation, such as DL eICIC or CoMP. The coordination set (or cluster) can be defined as a set of nodes connected with each other via backhaul link and performing coordinated transmissions.

FIG. 1 illustrates association biasing being applied at the mobile device **430** to the second LPN **420B** in a second coordination set, where the mobile device is associated (and in direction communication **440A**) with the first macro node **410A** in a first coordination set. The mobile device may receive a first macro node transmission **440A** from the first macro node and a second LPN transmission **450B** from the second LPN. In the example illustrated in FIG. 1, the first LPN **420A** is in the first coordination set with the first macro node, and the second LPN is in the second coordination set with the second macro node **420B**. The two coordination sets can generate independent transmissions, perform independent coordination, and/or perform independent interference mitigation from each other. In the example, the mobile device

may be originally located in the coverage area of the first macro node, which can indicate that the mobile device receives the strongest power from the first macro node. After applying a range expansion, via association biasing, such as RS biasing, the mobile device can reside in the range expansion zone of the second LPN, which can belong to the another coordination set, such as the second coordination set. Interference mitigation for the mobile device may be performed for the second coordination set, while the interference suppression from the strongest interferer (the first macro node) may not be achieved, due to independent coordination decision at the first coordination set and the second coordination set.

Association biasing, and hence range expansion of LPNs, may be applied to LPNs within the macro node's coordination set without applying association biasing to LPN outside the macro node's coordination set to improve performance of the mobile devices after the re-association with the LPNs. In an example, the macro node can inform the mobile devices of a specified association biasing value, such as a RS biasing value, and the LPNs belonging to the same coordination set as the macro node (in the coordination set information). The range expansion can be applied at the mobile for a restricted set of LPNs belonging to the same coordination set (or cooperation set) of the macro node. LPNs outside the restricted set may not receive the range expansion.

For example, FIG. 2 illustrates a second mobile device **430A** applying range expansion **424A** for the first LPN node **420A** in a same coordination set as the first macro node **410A**, and a first mobile device **430B** not applying range expansion (or maintaining a standard range **422B**) for the second LPN node **420B** in a different coordination set as the first macro node. The first mobile device may receive a first-macro-node-to-first-mobile-device transmission **440A** from the first macro node and a second LPN transmission **450B** from the second LPN. The second mobile device may receive a first-macro-node-to-second-mobile-device transmission **442A** from the first macro node and a first LPN transmission **450A** from the first LPN. Both the first mobile device and the second mobile can receive the coordination set information (for a first coordination set) for the LPNs (or other nodes) associated with the first macro node. Both the first mobile device and the second mobile can receive a request to apply a specified RS biasing. The request can include the specified RS biasing value or the mobile device can apply a predetermined RS biasing value stored within the mobile device. For example, the specified RS biasing can be a 3 dB value to be applied to a RSRP measurement. An RSRP can be measured in dBm and can have a range of -140 dBm to -44 dBm. The first mobile device can generate (through a measurement) a first RSRP for the first macro node to be -80 dBm and generate a second RSRP for the second LPN to be -82 dBm. Because the first RSRP has a higher value than the second RSRP, the first mobile device associates with the first macro node. The second mobile device can generate (through a measurement) a third RSRP for the first macro node to be -81 dBm and generate a fourth RSRP for the first LPN to be -83 dBm. Because the third RSRP has a higher value than the fourth RSRP, the second mobile device associates with the first macro node. Since the first LPN is in the same coordination set as the first macro node, the specified RS biasing can be applied to the first LPN. Thus, the RS biasing increases the apparent (or virtual) fourth RSRP value to -80 dBm (-83 dBm RSRP measurement plus the 3 dB offset of the specified RS biasing). Since, the fourth RSRP value is now greater than the third RSRP of -81 dBm, the second mobile device may

re-associate with the first LPN by transferring communication from the first macro node to the first LPN.

In the example, since the second LPN **420B** is in a different coordination set as the first macro node **410A**, the first mobile device **430B** may not apply the specified RS biasing to the second LPN **420B**. Thus, the first RSRP value for the first macro node of -80 dBm remains higher than the second RSRP value for the second LPN of -82 dBm. Thus, no re-association from the first macro node to the second LPN may occur. The first mobile device may remain associated **444A** with the first macro device and the second LPN may have a standard range (no range expansion), as illustrated in FIG. 3. The second mobile device **430A** may be re-associated **454A** with first LPN **420A** with a range expansion.

In an LTE network, a UE can measure as least two parameters on a reference signal, including a reference signal received power (RSRP) and a reference signal received quality (RSRQ). RSRP can be defined as a linear average over the power contributions (in [W]) of the resource elements that carry cell-specific reference signals (CRS) within a considered measurement frequency bandwidth. For RSRP determination the CRS R_0 may be used. If the mobile can reliably detect that R_1 is available, R_1 in addition to R_0 may be used to determine RSRP. The reference point for the RSRP may be an antenna connector of the mobile device. RSRQ can be defined as the ratio $N \times \text{RSRP} / (\text{E-UTRA carrier RSSI})$, where N is the number of resource blocks (RBs) of an evolved universal terrestrial radio access (E-UTRA) carrier received signal strength indicator (RSSI) measurement bandwidth. The measurements in the numerator and denominator can be made over the same set of resource blocks. The E-UTRA carrier RSSI can comprise the linear average of the total received power (in [W]) observed in OFDM symbols containing reference symbols for an antenna port 0 , in the measurement bandwidth, over N number of resource blocks by the UE from all sources, including co-channel serving and non-serving cells, adjacent channel interference, and/or thermal noise. The reference point for the RSRQ may be the antenna connector of the UE.

Association biasing can also be used in a Coordinated MultiPoint (CoMP) system (also known as multi-eNodeB multiple input multiple output [MIMO]) to improve interference mitigation. FIG. 4A illustrates an example of an inter-site CoMP system **308**. The CoMP system can be illustrated as a plurality of cooperating transmitting stations (outlined with a bold line) surrounded by a plurality of non-cooperating transmitting stations. In a CoMP system, the transmitting stations can be grouped together as cooperating transmitting stations **310A-C** in adjacent cells, where the cooperating transmitting stations from multiple cells can transmit signals to the mobile device **302** and receive signals from the mobile device. Each transmitting station can serve multiple cells (or sectors) **320A-K**, **322A-K**, and **324A-K**. The cell can be a logical definition generated by the transmitting station or geographic transmission area or sub-area (within a total coverage area) covered by the transmitting station, which can include a specific cell identification (ID) that defines the parameters for the cell, such as control channels, reference signals, and component carriers (CC) frequencies. By coordinating transmission among multiple cells, interference from other cells can be reduced and the received power of the desired signal can be increased. The cooperating transmitting stations can coordinate transmission/reception of signals from/to the mobile device. The transmitting stations outside the CoMP system can be non-cooperating transmitting stations **312D-K**. The cooperating transmitting stations of each

CoMP system can be included in a coordinating set, which can be used in association biasing.

In an intra-site CoMP example illustrated in FIG. 4B, LPNs (or RRHs) of a macro node **310A** may be located at different locations in space, and CoMP coordination may be within a single macro, similar to HetNet. A cell **322A** of a macro node may be further sub-divided into sub-cells **330**, **332**, and **334**. LPNs (or RRHs) **380**, **382**, and **384** may transmit and receive signals for a sub-cell. LPNs (or RRHs) **370** and **374** may transmit and receive signals for a cell **320A** and **324A**. A mobile communication device **302** can be on a sub-cell edge (or cell-edge) and intra-site CoMP coordination can occur between the LPNs (or RRHs).

Downlink (DL) CoMP transmission can be divided into two categories: coordinated scheduling or coordinated beamforming (CS/CB or CS/CBF), and joint processing or joint transmission (JP/JT). With CS/CB, a given subframe can be transmitted from one cell to a given mobile communication device (UE), and the scheduling, including coordinated beamforming, is dynamically coordinated between the cells in order to control and/or reduce the interference between different transmissions. For joint processing, joint transmission can be performed by multiple cells to a mobile communication device (UE), in which multiple transmitting stations transmit at the same time using the same time and frequency radio resources and dynamic cell selection. Two methods can be used for joint transmission: non-coherent transmission, which uses soft-combining reception of the OFDM signal; and coherent transmission, which performs precoding between cells for in-phase combining at the receiver. By coordinating and combining signals from multiple antennas, CoMP, allows mobile users to enjoy consistent performance and quality for high-bandwidth services whether the mobile user is close to the center of a cell or at the outer edges of the cell.

Another example provides a method **500** for association biasing at a mobile device in a heterogeneous network (HetNet), as shown in the flow chart in FIG. 5. The method includes the operation of receiving coordination set information from a macro node in the HetNet at the mobile device, wherein the coordination set information includes at least one low power node (LPN) identifier of at least one LPN, as in block **510**. The operation of receiving a request from the macro node at the mobile device to apply a specified reference signal (RS) biasing follows, as in block **520**. The next operation of the method can be applying the specified RS biasing at the mobile device to an LPN RS measurement derived from a LPN RS received from an LPN having an LPN identifier in the received coordination set information, as in block **530**. The method further includes associating the mobile device with the LPN when the LPN RS measurement with the specified RS biasing exceeds an association threshold, as in block **540**.

Associating the mobile device with the LPN can include associating the mobile device with the LPN when the LPN RS measurement with the specified RS biasing exceeds a macro node RS measurement by a predetermined amount. The predetermined amount can include a tolerance or margin to reduce a likelihood of a re-association between the macro node and LPN with a minor fluctuation in the RS measurement, either LPN RS measurement or the macro node RS measurement. The predetermined amount can reduce an excessive re-association between the macro node and the LPN. The mobile device can measure the LPN RS from the LPN to generate the LPN RS measurement. The mobile device can measure a macro node RS from the macro node to generate the macro node RS measurement. At least one LPN

in a coordinating set can have coordinated signaling with the macro node in the coordinating set. The request from the macro node at the mobile device to apply the specified RS biasing can be used to offload traffic at the macro node. The mobile device applying the specified RS biasing to the LPN RS measurement can expand a range for the mobile device to associate with the LPN. The mobile device can associate with the LPN and send a re-association request from the mobile device to the macro node to associate with the LPN. The re-association request instructs the macro node to offload communication with the mobile device to the LPN. The re-association request can include a LPN RS measurement taken by the mobile device. The mobile device can associate with the LPN and transfer communication from the macro node to the LPN.

FIG. 6 illustrates an example node and an example mobile device 720 in a HetNet. The node 710 can include a macro node (or macro-eNB) or a low power node (micro-eNB, a pico-eNB, a femto-eNB, or a HeNB). The node can include a wireless transceiver 712 and a backhaul link transceiver 714. The wireless transceiver of the node can be configured to transmit coordination set information to a mobile device and transmit a request to the mobile device in the HetNet to apply a specified reference signal (RS) biasing to a LPN RS measurement derived from a LPN RS received from the at least one LPN in the coordination set. The coordination set information can include a LPN identifier for the at least one LPN having coordinated signaling with the macro node. The backhaul link transceiver of the node can be configured to communicate with the at least one LPN and transfer an association with the mobile device to one of the at least one LPNs in the coordination set when a LPN RS measurement with the specified RS biasing exceeds an association threshold.

The mobile device (or UE) 720 can be in communication with a macro node (or macro eNodeB) or a low power node (or micro eNodeB, pico eNodeB, femto eNodeB, or HeNB). In an example, an available transmission power of the macro node may be at least ten times an available transmission power of the LPN.

The mobile device 720 can include a transceiver 722 and a processing module 724. The transceiver of the mobile device can be configured to receive coordination set information from a macro node in the HetNet and receive a request from the macro node to apply a specified RS biasing. The coordination set information can include at least one LPN identifier of at least one LPN having coordinated signaling with the macro node. The processing module of the mobile device can be configured to apply the specified RS biasing to a LPN RS measurement when a LPN has a LPN identifier in the received coordination set information, and trigger an association with the LPN when the LPN RS measurement with the specified RS biasing exceeds an association threshold by a predetermined amount. The predetermined amount can have a value of zero. The association threshold can be based on a macro node RS measurement. The processing module can be further configured to measure a LPN RS to generate a LPN RS measurement and/or measure a macro node RS to generate a macro node RS measurement.

In another example, a transmission station can be in wireless communication with a mobile device. FIG. 7 provides an example illustration of the mobile device, such as a user equipment (UE), a mobile station (MS), a mobile wireless device, a mobile communication device, a tablet, a handset, or other type of mobile wireless device. The mobile device can include one or more antennas configured to communicate with a node, macro node, low power node (LPN), or, transmission station, such as a base station (BS), an evolved Node

B (eNB), a base band unit (BBU), a remote radio head (RRH), a remote radio equipment (RRE), a relay station (RS), a radio equipment (RE), or other type of wireless wide area network (WWAN) access point. The mobile device can be configured to communicate using at least one wireless communication standard including 3GPP LTE, WiMAX, High Speed Packet Access (HSPA), Bluetooth, and WiFi. The mobile device can communicate using separate antennas for each wireless communication standard or shared antennas for multiple wireless communication standards. The mobile device can communicate in a wireless local area network (WLAN), a wireless personal area network (WPAN), and/or a WWAN.

FIG. 7 also provides an illustration of a microphone and one or more speakers that can be used for audio input and output from the mobile device. The display screen may be a liquid crystal display (LCD) screen, or other type of display screen such as an organic light emitting diode (OLED) display. The display screen can be configured as a touch screen. The touch screen may use capacitive, resistive, or another type of touch screen technology. An application processor and a graphics processor can be coupled to internal memory to provide processing and display capabilities. A non-volatile memory port can also be used to provide data input/output options to a user. The non-volatile memory port may also be used to expand the memory capabilities of the mobile device. A keyboard may be integrated with the mobile device or wirelessly connected to the mobile device to provide additional user input. A virtual keyboard may also be provided using the touch screen.

Various techniques, or certain aspects or portions thereof, may take the form of program code (i.e., instructions) embodied in tangible media, such as floppy diskettes, CD-ROMs, hard drives, non-transitory computer readable storage medium, or any other machine-readable storage medium wherein, when the program code is loaded into and executed by a machine, such as a computer, the machine becomes an apparatus for practicing the various techniques. In the case of program code execution on programmable computers, the computing device may include a processor, a storage medium readable by the processor (including volatile and non-volatile memory and/or storage elements), at least one input device, and at least one output device. The volatile and non-volatile memory and/or storage elements may be a RAM, EPROM, flash drive, optical drive, magnetic hard drive, or other medium for storing electronic data. The base station and mobile device may also include a transceiver module, a counter module, a processing module, and/or a clock module or timer module. One or more programs that may implement or utilize the various techniques described herein may use an application programming interface (API), reusable controls, and the like. Such programs may be implemented in a high level procedural or object oriented programming language to communicate with a computer system. However, the program(s) may be implemented in assembly or machine language, if desired. In any case, the language may be a compiled or interpreted language, and combined with hardware implementations.

It should be understood that many of the functional units described in this specification have been labeled as modules, in order to more particularly emphasize their implementation independence. For example, a module may be implemented as a hardware circuit comprising custom VLSI circuits or gate arrays, off-the-shelf semiconductors such as logic chips, transistors, or other discrete components. A module may also be implemented in programmable hardware devices such as field programmable gate arrays, programmable array logic, programmable logic devices or the like.

11

Modules may also be implemented in software for execution by various types of processors. An identified module of executable code may, for instance, comprise one or more physical or logical blocks of computer instructions, which may, for instance, be organized as an object, procedure, or function. Nevertheless, the executables of an identified module need not be physically located together, but may comprise disparate instructions stored in different locations which, when joined logically together, comprise the module and achieve the stated purpose for the module.

Indeed, a module of executable code may be a single instruction, or many instructions, and may even be distributed over several different code segments, among different programs, and across several memory devices. Similarly, operational data may be identified and illustrated herein within modules, and may be embodied in any suitable form and organized within any suitable type of data structure. The operational data may be collected as a single data set, or may be distributed over different locations including over different storage devices, and may exist, at least partially, merely as electronic signals on a system or network. The modules may be passive or active, including agents operable to perform desired functions.

Reference throughout this specification to “an example” means that a particular feature, structure, or characteristic described in connection with the example is included in at least one embodiment of the present invention. Thus, appearances of the phrases “in an example” in various places throughout this specification are not necessarily all referring to the same embodiment.

As used herein, a plurality of items, structural elements, compositional elements, and/or materials may be presented in a common list for convenience. However, these lists should be construed as though each member of the list is individually identified as a separate and unique member. Thus, no individual member of such list should be construed as a de facto equivalent of any other member of the same list solely based on their presentation in a common group without indications to the contrary. In addition, various embodiments and example of the present invention may be referred to herein along with alternatives for the various components thereof. It is understood that such embodiments, examples, and alternatives are not to be construed as defacto equivalents of one another, but are to be considered as separate and autonomous representations of the present invention.

Furthermore, the described features, structures, or characteristics may be combined in any suitable manner in one or more embodiments. In the following description, numerous specific details are provided, such as examples of layouts, distances, network examples, etc., to provide a thorough understanding of embodiments of the invention. One skilled in the relevant art will recognize, however, that the invention can be practiced without one or more of the specific details, or with other methods, components, layouts, etc. In other instances, well-known structures, materials, or operations are not shown or described in detail to avoid obscuring aspects of the invention.

While the forgoing examples are illustrative of the principles of the present invention in one or more particular applications, it will be apparent to those of ordinary skill in the art that numerous modifications in form, usage and details of implementation can be made without the exercise of inventive faculty, and without departing from the principles and concepts of the invention. Accordingly, it is not intended that the invention be limited, except as by the claims set forth below.

12

What is claimed is:

1. A system for association biasing at a mobile device in a heterogeneous network (HetNet), comprising:
 - a means for receiving coordination set information from a macro node in the HetNet at the mobile device, wherein the coordination set information includes at least one low power node (LPN) identifier of at least one LPN;
 - a means for receiving a request from the macro node at the mobile device to apply a specified reference signal (RS) biasing;
 - a means for applying the specified RS biasing at the mobile device to an LPN RS measurement derived from a LPN RS received from an LPN having an LPN identifier in the received coordination set information; and
 - a means for associating the mobile device with the LPN when the LPN RS measurement with the specified RS biasing exceeds an association threshold.
2. The system of claim 1, wherein the LPN RS measurement includes a measurement selected from the group consisting of a reference signal received power (RSRP), a reference signal received quality (RSRQ), and combinations thereof.
3. The system of claim 1, wherein the specified RS biasing has a range greater than 0 decibel (dB) to about 16 dB.
4. The system of claim 1, wherein the means for associating the mobile device with the LPN further comprises a means for associating the mobile device with the LPN when the LPN RS measurement with the specified RS biasing exceeds a macro node RS measurement by a predetermined amount.
5. The system of claim 4, further comprising prior to applying the specified RS biasing at the mobile device:
 - a means for measuring a LPN RS from the LPN to generate the LPN RS measurement; and
 - a means for measuring a macro node RS from the macro node to generate the macro node RS measurement.
6. The system of claim 1, wherein at least one LPN in a coordinating set has coordinated signaling with the macro node in the coordinating set.
7. The system of claim 1, wherein the means for associating with the LPN further comprises a means for sending a re-association request from the mobile device to the macro node to associate with the LPN, wherein the re-association request instructs the macro node to offload communication with the mobile device to the LPN.
8. The system of claim 7, wherein the re-association request includes a LPN RS measurement taken by the mobile device.
9. The system of claim 1, wherein the means for associating with the LPN transfers communication from the macro node to the LPN.
10. A mobile device in a heterogeneous network (HetNet), comprising:
 - a transceiver configured to receive coordination set information from a macro node in the HetNet and receive a request from the macro node to apply a specified reference signal (RS) biasing, wherein the coordination set information includes at least one low power node (LPN) identifier of at least one LPN having coordinated signaling with the macro node; and
 - a processing module configured to apply the specified RS biasing to a LPN RS measurement when a LPN has a LPN identifier in the received coordination set information, and trigger an association with the LPN when the LPN RS measurement with the specified RS biasing exceeds an association threshold.
11. The mobile device of claim 10, wherein the LPN RS measurement includes a measurement selected from the

13

group consisting of a reference signal received power (RSRP), a reference signal received quality (RSRQ), and combinations thereof.

12. The mobile device of claim **10**, wherein the specified RS biasing has a range greater than 0 decibel (dB) to about 16 dB. 5

13. The mobile device of claim **10**, wherein the association threshold is based on a macro node RS measurement.

14. The mobile device of claim **13**, wherein the processing module is further configured to measure a LPN RS to generate a LPN RS measurement and measure a macro node RS to generate a macro node RS measurement. 10

15. The mobile device of claim **10**, wherein the mobile device includes a user equipment (UE) with an antenna, a touch sensitive display screen, a speaker, a microphone, a graphics processor, an application processor, internal memory, a non-volatile memory port, or combinations thereof. 15

16. A macro node in a heterogeneous network (HetNet) having a coordination set including at least one low power node (LPN), comprising: 20

a wireless transceiver configured to transmit coordination set information to a mobile device and transmit a request to the mobile device in the HetNet to apply a specified reference signal (RS) biasing to a LPN RS measurement derived from a LPN RS received from the at least one LPN in the coordination set, wherein the coordination 25

14

set information includes a LPN identifier for the at least one LPN having coordinated signaling with the macro node; and

a backhaul link transceiver configured to communicate with the at least one LPN and transfer an association with the mobile device to one of the at least one LPNs in the coordination set when a LPN RS measurement with the specified RS biasing exceeds an association threshold. 5

17. The macro node of claim **16**, wherein the specified RS biasing has a range greater than 0 decibel (dB) to about 16 dB. 10

18. The macro node of claim **16**, further comprising a processing module configured for implementing an enhanced inter-cell interference coordination (eICIC), coordinated multi-point (CoMP), or combination of thereof for the nodes in the coordination set when the specified RS biasing is requested. 15

19. The macro node of claim **16**, wherein the coordinated signaling includes X2 signaling or backhaul link signaling via a wired connection, a wireless connection, or an optical fiber connection. 20

20. The macro node of claim **16**, wherein the macro node includes a macro evolved Node B (macro-eNB) and the LPN includes a micro-eNB, a pico-eNB, a femto-eNB, or a home eNB (HeNB). 25

* * * * *