



US009271174B2

(12) **United States Patent**  
**Choi**

(10) **Patent No.:** **US 9,271,174 B2**  
(45) **Date of Patent:** **Feb. 23, 2016**

(54) **COMMUNICATION DEVICE PERFORMING MEASUREMENTS USING ASSIGNED TIME SLOTS**

2006/0223557 A1 10/2006 Manohar  
2007/0037594 A1\* 2/2007 Palenius et al. .... 455/502  
2007/0037601 A1 2/2007 Mittal et al.  
2007/0207824 A1\* 9/2007 Bhattacharjee et al. .... 455/513

(75) Inventor: **Hyung-Nam Choi**, Hamburg (DE)

FOREIGN PATENT DOCUMENTS

(73) Assignee: **INTEL DEUTSCHLAND GMBH**, Neubiberg (DE)

DE 102 25 912 A1 11/2003

(\*) Notice: Subject to any disclaimer, the term of this patent is extended or adjusted under 35 U.S.C. 154(b) by 1694 days.

OTHER PUBLICATIONS

(21) Appl. No.: **11/835,192**

3GPP TS 25.215 V3.13.0 (Mar. 2005); *Technical Specification*; 3rd Generation Partnership Project; Technical Specification Group Radio Access Network; Physical layer—Measurements (FDD) (Release 999).

(22) Filed: **Aug. 7, 2007**

3GPP TS 34.108 V6.5.0 (Dec. 2006); *Technical Specification*; 3rd Generation Partnership Project; Technical Specification Group Radio Access Network; Common test environments for User Equipment (UE); Conformance testing (Release 6).

(65) **Prior Publication Data**

US 2009/0042559 A1 Feb. 12, 2009

\* cited by examiner

(51) **Int. Cl.**  
**H04W 24/10** (2009.01)

*Primary Examiner* — Gerald Johnson

(52) **U.S. Cl.**  
CPC ..... **H04W 24/10** (2013.01)

(74) *Attorney, Agent, or Firm* — Schwabe, Williamson & Wyatt, P.C.

(58) **Field of Classification Search**  
CPC ..... H04W 24/10  
USPC ..... 455/437, 423–425  
See application file for complete search history.

(57) **ABSTRACT**

A method for performing a measurement by a communication device including selecting at least one measurement type of a plurality of measurement types, wherein each measurement type is assigned to a time slot, wherein the at least one measurement type is selected for a time interval which is pre-defined as a transmission gap of a receiver of the communication device for carrying out measurements by the receiver corresponding to the time slot; and performing a measurement of the at least one measurement type during the time interval.

(56) **References Cited**

U.S. PATENT DOCUMENTS

6,810,019 B2\* 10/2004 Steudle ..... 370/252  
7,330,732 B2\* 2/2008 Wilborn et al. .... 455/502  
2005/0250495 A1 11/2005 Black et al.

**16 Claims, 3 Drawing Sheets**

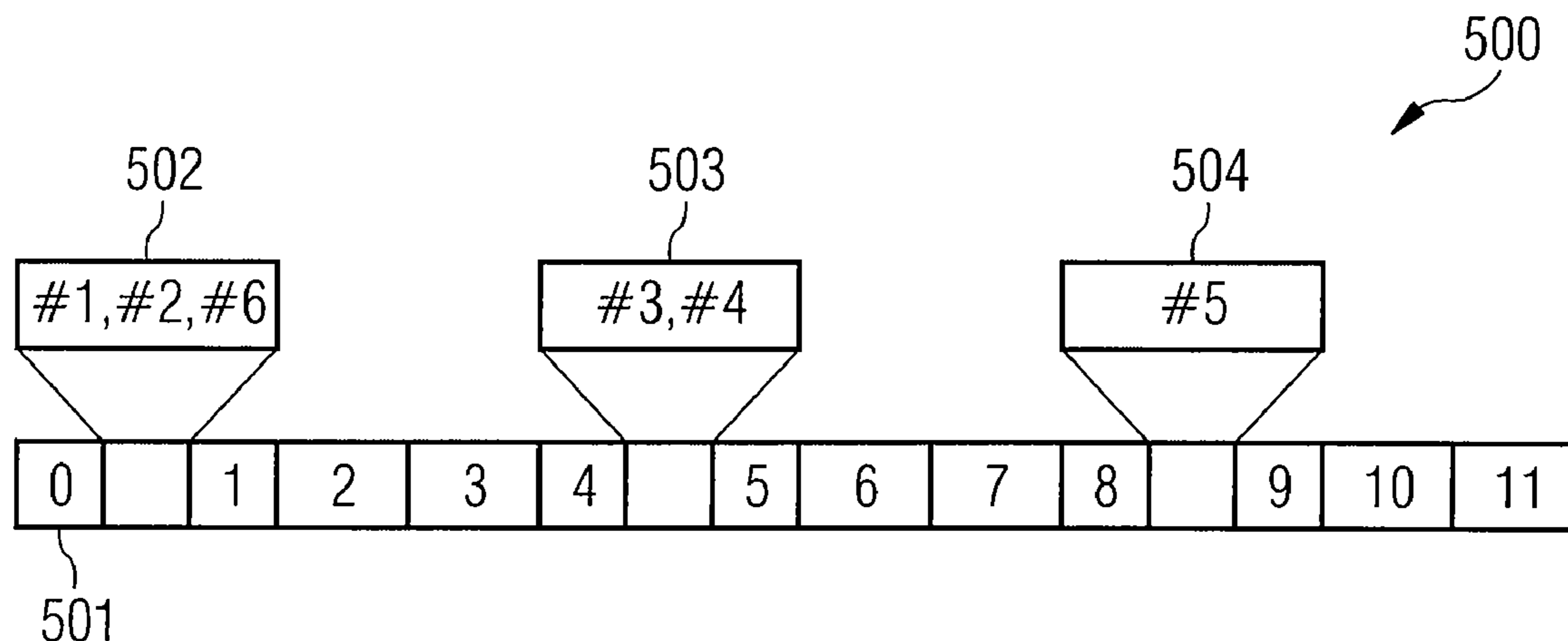

FIG 1

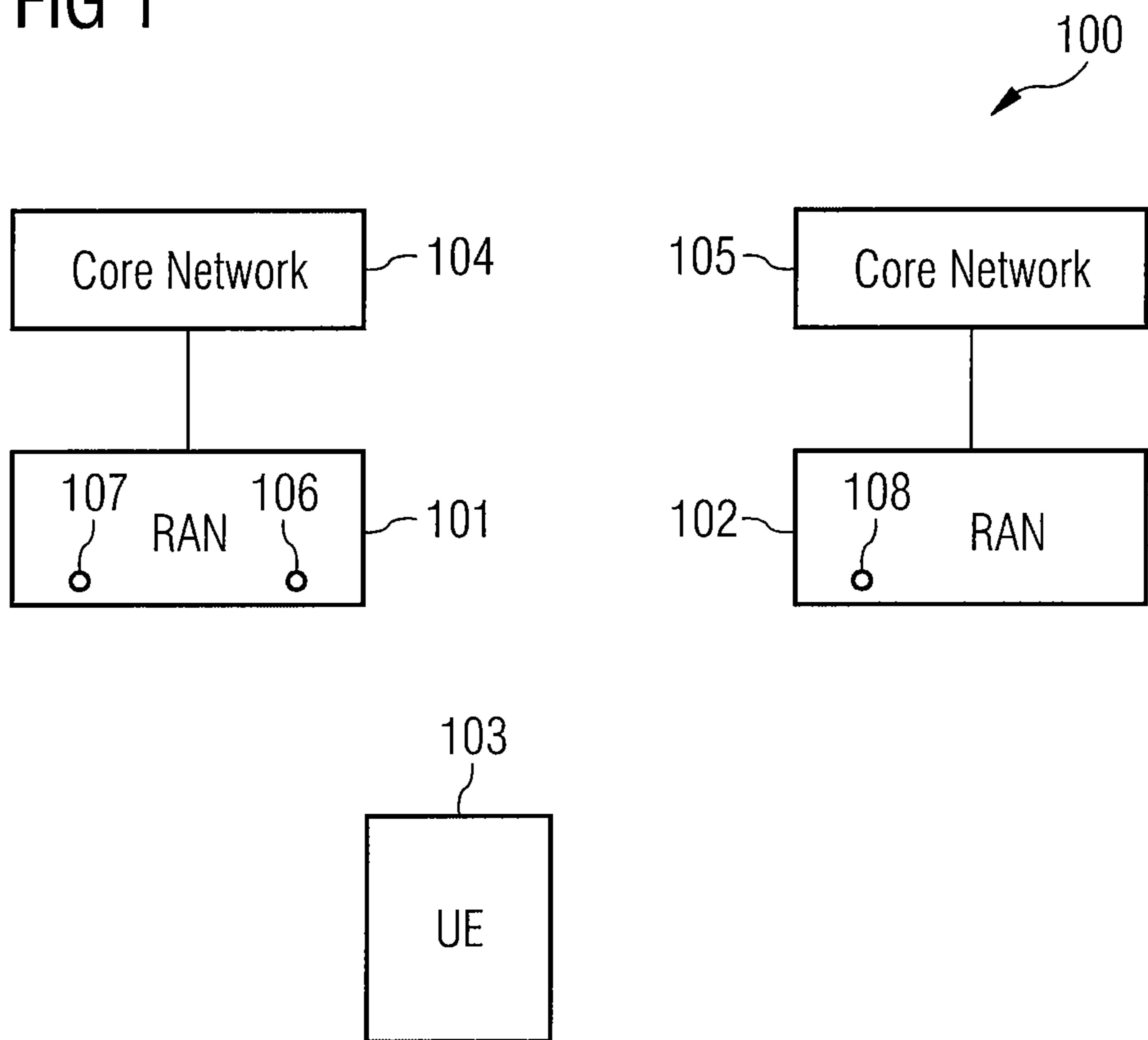



FIG 3

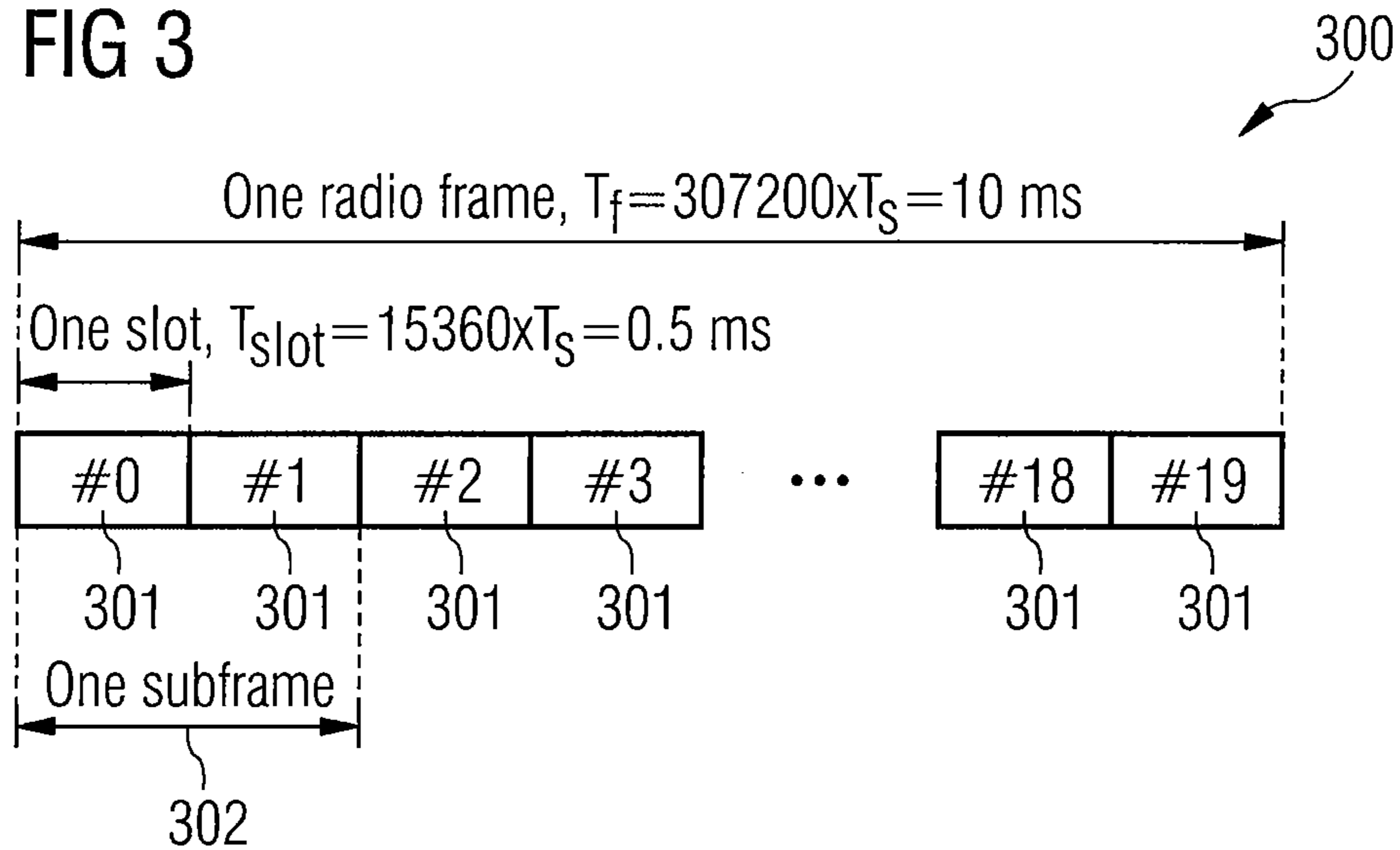

FIG 4

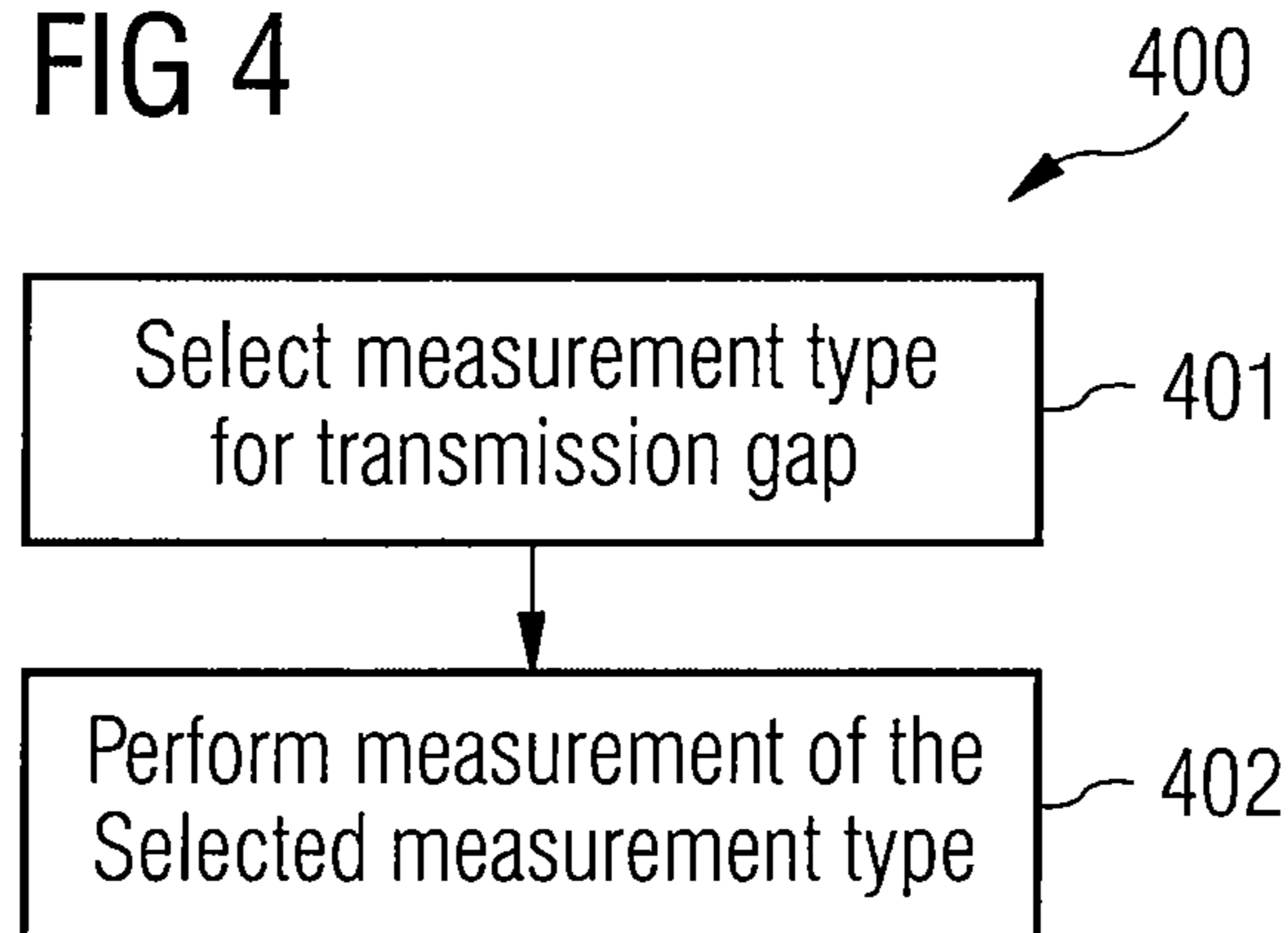
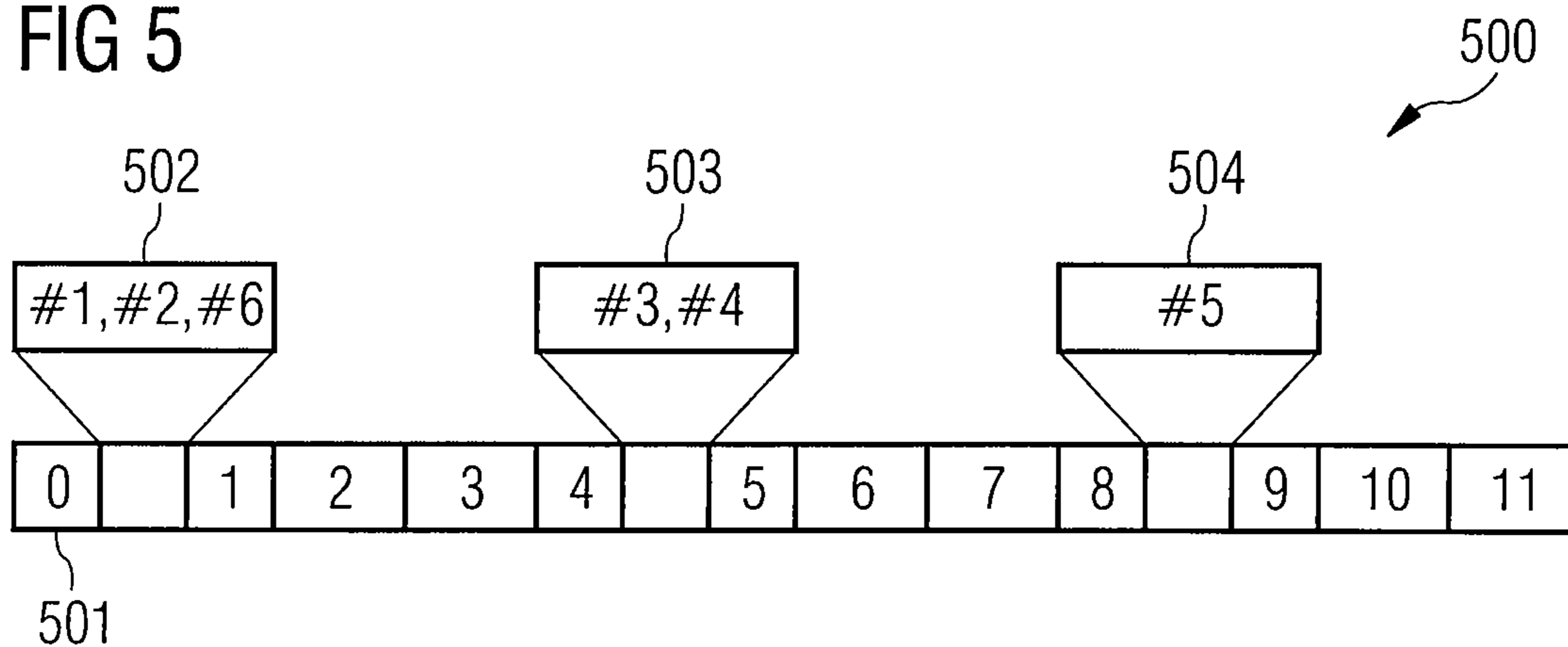

FIG 5





## 1

**COMMUNICATION DEVICE PERFORMING  
MEASUREMENTS USING ASSIGNED TIME  
SLOTS**

BACKGROUND

Embodiments of the invention relate generally to a method for performing a measurement by a communication device and a communication device.

SUMMARY

A method for performing a measurement by a communication device including selecting at least one measurement type of a plurality of measurement types, wherein each measurement type is assigned to a time slot, wherein the at least one measurement type is selected for a time interval which is pre-defined as a transmission gap of a receiver of the communication device for carrying out measurements by the receiver corresponding to the time slot; and performing a measurement of the at least one measurement type during the time interval.

BRIEF DESCRIPTION OF THE DRAWINGS

In the drawings, like reference characters generally refer to the same parts throughout the different views. The drawings are not necessarily to scale, emphasis instead generally being placed upon illustrating the principles of the invention. In the following description, various embodiments of the invention are described with reference to the following drawings, in which:

FIG. 1 shows a communication system according to an embodiment of the invention;

FIG. 2 shows transmission gap patterns for carrying out inter frequency and inter RAT measurements;

FIG. 3 shows a radio frame structure according to an embodiment of the invention;

FIG. 4 shows a flow diagram according to an embodiment of the invention; and

FIG. 5 shows a transmission gap pattern according to an embodiment of the invention.

DESCRIPTION

In the current UMTS mobile radio communication standard (Universal Mobile Telecommunications Systems communications standard), also called Release 7, a maximum net transmission rate of 28.8 Mbps is supported in the downlink transmission direction and of 11.52 Mbps is supported in the uplink transmission direction. The uplink transmission direction, also called the uplink, denotes signal transmission from the mobile radio communication terminal to the respective UMTS base station. The downlink transmission direction also called the downlink, denotes signal transmission from the respective associated UMTS base station to the mobile radio communication terminal. Radio transmission technologies currently specified are Frequency Division Duplex (FDD) and Time Division Duplex (TDD). The multiple access method used is based on Code Division Multiple Access (CDMA) technology.

A current topic in the 3GPP standardization committees (3GPP: 3<sup>rd</sup> Generation Partnership Project) is the further development of UMTS towards a mobile radio communication system optimized for packet data transmission by improving the system capacity and by improving the spectral efficiency. In 3GPP, the activities in this regard are summarized under the general term LTE for Long Term Evolution.

## 2

The aim is amongst others to increase the maximum net transmission rate significantly in future, namely to 100 Mbps in the downlink transmission direction and to 50 Mbps in the uplink transmission direction. To improve transmission via the air interface, new multiple access methods have inter alia been specified.

For the downlink transmission direction OFDMA (Orthogonal Frequency Division Multiple Access) in combination with TDMA (Time Division Multiple Access) has been specified. OFDMA in combination with TDMA, subsequently also called OFDMA/TDMA, is a multicarrier multiple access method in which a subscriber is provided with a defined number of subcarriers in the frequency spectrum and a defined transmission time for the purpose of data transmission.

Uplink data transmission is based on SC-FDMA (Single Carrier Frequency Division Multiple Access) in combination with TDMA.

In the UMTS FDD mode according to Release 7, the so-called compressed mode is specified to give a mobile terminal (also denoted as user equipment, UE, in UMTS) which, e.g. for saving costs, only includes one receiver, the opportunity to carry out inter frequency measurements, i.e. measurements of the reception quality of UMTS radio cells which are operated using a different frequency band than the radio cell in which the mobile terminal is currently located, and inter-RAT (radio access technology) measurements, i.e. measurements of the reception quality of radio cells of a mobile communication system operated according to a different radio access technology, for example a GSM (Global System for Mobile Communications) mobile communication system. According to compressed mode, transmission gaps in the uplink transmission and/or the downlink transmission are specified which can be used by a mobile terminal to carry out such measurements.

In the case of downlink, for example, the base station (also denoted by NodeB) temporarily suspends the data transmission to the mobile terminal for the duration of the specified (downlink) transmission gaps. In the case of uplink, the mobile terminal temporarily suspends the data transmission to the base station for the duration of the specified (uplink) transmission gaps.

This is explained in more detail in the following with reference to FIG. 1.

FIG. 1 shows a communication system **100** according to an embodiment of the invention.

The communication system **100** includes a first radio access network **101**, a second radio access network **102** and a mobile terminal **103**. The first radio access network **101** is for example the radio access network of a UMTS communication network, also denoted as UTRAN (UMTS Terrestrial Radio Access Network) and is coupled with a first core network **104** of the UMTS communication network. The second radio access network **102** is in this example a radio access network according to another radio access technology than the one according to UMTS, for example the radio access network of a mobile communication network according to GSM, FOMA (Freedom of Mobile Access) or CDMA2000 (CDMA: Code Division Multiple Access), which includes a second core network **105** to which the second radio access network **102** is coupled. It is assumed that the mobile terminal **103** is located in a radio cell operated by a first base station **106** of the first radio access network **101**. The mobile terminal **103** may receive data sent by the first base station **106** (i.e. in downlink) and may send data to the first base station **106** (i.e. in uplink).



The mobile terminal **103** may carry out measurements of the reception quality of other radio cells of the first radio access network **101**, for example of a radio cell neighboring the radio cell in which the mobile terminal **103** is located and operated by a second base station **107** of the first radio access network **101**. The measurement of the reception quality in the radio cell operated by the second base station **107**, i.e. the reception quality of data sent by the second base station **107**, is for example an inter frequency measurement, i.e. the radio cell operated by the second base station **107** is operated in another frequency band than the radio cell in which the mobile terminal **103** is located, i.e. for data transmission to and from the second base station **107** a different frequency band is used than for data transmission to and from the first base station **106**.

The mobile terminal **103** may also carry out measurements of the reception quality (e.g. the signal to noise ratio) of radio cells operated by the second radio access network **102**, for example in the radio cell operated by a third base station **108** of the second radio access network **102**. Since in this example, the second radio access network **102** uses a different radio access technology than the first radio access network

corresponding compressed mode parameters which are signaled by the first base station **106** to the mobile terminal **103**. The compressed mode parameters for example specify the length of each transmission gap TGL (transmission gap length), the time difference between the beginnings of two transmission gaps TGD (transmission gap start distance) and the duration of the usage of the transmission gaps TGPL (transmission gap pattern length).

Measurements of a multiplicity of inter frequency measurement types and inter RAT measurement types may be carried out by the mobile terminal **103**. For each measurement type individual compressed mode parameters may be defined. This means that for each measurement type, an individual transmission gap pattern may be defined. A measurement of a certain measurement type may only be carried out in a transmission gap defined for this measurement type. The transmission gap patterns such that transmission gaps defined for different measurement types do not overlap. As an example, in table 1 the configuration of compressed mode parameters for one inter frequency measurement type and three inter RAT measurement types are shown.

TABLE 1

Parameter	Inter-Frequency FDD	GSM Carrier RSSI	GSM Initial BSIC identification	GSM BSIC re-confirmation
TGSN (Transmission Gap Starting Slot Number)	8	8	8	8
TGL1 (Transmission Gap Length 1)	14	14	14	14
TGL2 (Transmission Gap Length 2)	14	14	14	14
TGD (Transmission Gap Distance)	0	60	45	0
TGPL1 (Transmission Gap Pattern Length)	12	24	24	24
TGPL2 (Transmission Gap Pattern Length)	—	—	—	—
TGCFN (Transmission Gap Connection Frame Number):	(Current CFN + (238 – TTI/10 msec)) mod 256	(Current CFN + (242 – TTI/10 msec)) mod 256	(Current CFN + (256 – TTI/10 msec)) mod 256	(Current CFN + (253 – TTI/10 msec)) mod 256
UL/DL compressed mode selection	DL, UL or DL & UL	DL, UL or DL & UL	DL, UL or DL & UL	DL, UL or DL & UL
UL compressed mode method	SF/2	SF/2	SF/2	SF/2
DL compressed mode method	SF/2	SF/2	SF/2	SF/2

**101** the measurement of the reception quality in the radio cell operated by the third base station **108** is an inter RAT measurement.

Reception quality for example means the received power of one or more predefined signals (Reference Signal Received Power, RSRP) or a ratio of the received power of one or more predefined signals and the received interfering power (or power of the noise) received in the same frequency band as the predefined signals (Reference Signal Received Quality, RSRQ).

For carrying out inter frequency measurements or inter RAT measurements there may be specified transmission gaps based on the CDMA multiple access method according to the feature compressed mode. Compressed mode is a special feature of the UMTS FDD mode for generation of transmission gaps of uplink data transmission and downlink data transmission in the RRC (radio resource control) state CELL\_DCH. When the mobile terminal **103** is in the state CELL\_DCH dedicated radio resources are allocated by the first radio access network **101** for the mobile terminal **103** for data transmission between the first base station **106** and the mobile terminal **103**.

When measurements need to be carried out using the compressed mode the first radio access network **101** may define

Note that herein, the term measurement refers to an individual measurement which is carried out at some measurement time. A measurement is of a certain measurement type. For example, performing out a measurement according to a measurement type at a measurement time, e.g. during a measurement time interval, means that the reception power is measured in a radio cell at the measurement time. In this case the measurement type would for example be “measurement of the reception power in the radio cell”. A measurement type may be an inter frequency measurement type, i.e. measurements of the measurement type are inter frequency measurements, or it may be an inter RAT measurement type, i.e. measurements of the measurement type are inter RAT measurements.

In FIG. 2, transmission gap patterns for the four measurement types referred to in table 1 are shown.

FIG. 2 shows transmission gap patterns for carrying out inter frequency and inter RAT measurements.

A first transmission gap pattern **201** is the transmission gap pattern of an inter frequency measurement type. A second transmission gap pattern **202** is the transmission gap pattern of an inter RAT measurement type. In this example the received signal strength indicator (RSSI) of a GSM frequency carrier is measured.



A third transmission gap pattern **203** is the transmission gap pattern of an inter RAT measurement type. In this example, the reception quality of a frequency channel and a synchronization channel of GSM radio cells is measured.

A fourth transmission gap pattern **204** is the transmission gap pattern for carrying out measurements of an inter RAT measurement type, in this example the reception quality of the synchronization channel of GSM radio cells is measured.

There is further shown a fifth transmission gap pattern **205** which includes all the transmission gaps defined according to the first transmission gap pattern **201**, the second transmission gap pattern **202**, the third transmission gap pattern **203**, and the fourth transmission gap pattern **204**.

The transmission gap patterns **201** to **205** are illustrated in the form of a plurality of a radio frame **206**, in this example 24 radio frames (numbered from 0 to 23). The transmission gaps **207** defined for the respective transmission gap patterns include at least parts of the radio frames **206**. The structure of the radio frame **206** is shown in more detail in FIG. 3.

FIG. 3 shows a radio frame structure according to an embodiment of the invention.

According to the radio frame structure shown, a radio frame **300** has a length of 10 ms and includes 20 time slots **301** each of length 0.5 ms. Every two time slots **301** may be grouped to one sub frame **302** such that the radio frame **300** includes 10 sub frames of length 1 ms.

The lengths of time slots **301**, radio frames **300** and sub frames may be different from those given above in other embodiments. Further, in other embodiments, a radio frame includes not 20 time slots **301** but for example 15 time slots **301**.

In the example of transmission gap patterns shown in FIG. 2, each transmission gap includes 14 time slots **301**.

It can be seen that when transmission gap patterns are specified for a plurality of measurement types a lot of transmission gaps are generated altogether, such as in the combined transmission gap pattern **205**, the transmission gaps defined for the various measurement types do not overlap. This means that there are relatively many transmission gaps which can not be used for data transmission between the first base station **106** and the mobile terminal **103**. This effect is intensified with a high number of possible measurement types such as it is the case according to LTE because according to LTE there is a high number of inter RAT measurements due to the fact that a UMTS communication network according to LTE shall support not only inter working with GSM communication networks, i.e. the possibility for mobile terminals to use radio access networks according to GSM, but also with UMTS radio access networks based on CDMA, radio access networks based on mobile WiMAX and radio access networks according to 3GPP 2 (i.e. CDMA 2000).

Therefore, according to one embodiment of the invention, a method for performing a measurement by a communication device is provided, for example to be applied to the communication system described with reference to FIG. 1, in which case the communication device may correspond to the mobile terminal **103**, which is for example a UMTS mobile terminal according to LTE.

FIG. 4 shows a flow diagram **400** according to an embodiment of the invention.

The flow diagram **400** illustrates a method for performing a measurement by a communication device according to an embodiment of the invention.

In **401**, at least one measurement type of a plurality of measurement types is selected, wherein each measurement type is assigned to a time slot, wherein the at least one measurement type is selected for a time interval which is pre-

defined as a transmission gap of a receiver of the communication device for carrying out measurements by the receiver corresponding to the time slot.

In **402**, a measurement of the at least one measurement type is performed during the time interval.

The time slot does not need to correspond to a time slot of a frame structure as shown in FIG. 3, but may include more than one time slots of a frame or more than one subframe. It may also include time slots of adjacent radio frames.

Illustratively, according to one embodiment, one transmission gap may be specified for a plurality of measurement types and a communication device may select the measurement type of the plurality of measurement types according to which a measurement is actually performed. In other words, the transmission gaps for different measurement types may overlap, fully or partly. In this way, especially if there are a lot of measurement types, the number of transmission gaps defined may be reduced and the impact on the radio resources can be reduced, i.e. radio resources can be used for actual (useful) data transmission for a larger time period. Thus, for example, the delay of (useful) data transmissions may be reduced. In one embodiment, illustratively, a mobile device is provided with means to carry out measurements efficiently.

In one embodiment, the method illustrated in FIG. 4 further includes receiving a message specifying the assignment of the measurements types to the time slot.

Each measurement type may be assigned a priority and the at least one measurement type is for example selected based on the priorities of the measurement types.

In one embodiment, each measurement type is assigned a counter counting the number of measurements performed according to the measurement type and the at least one measurement type is selected based on the current values of the counters of the measurement types.

The communication device is for example a mobile terminal, e.g. a mobile terminal according to UMTS.

In one embodiment, the measurement is the measurement of the reception quality of a signal sent by a base station in a radio cell. For example, the measurement is the measurement of the reception field strength of a signal sent by a base station in a radio cell, e.g. a radio cell of a UMTS mobile communication system.

A memory used in the embodiments of the invention may be a volatile memory, for example a DRAM (Dynamic Random Access Memory) or a non-volatile memory, for example a PROM (Programmable Read Only Memory), an EPROM (Erasable PROM), EEPROM (Electrically Erasable PROM), or a flash memory, e.g., a floating gate memory, a charge trapping memory, an MRAM (Magnetoresistive Random Access Memory) or a PCRAM (Phase Change Random Access Memory).

A circuit can be a hardware circuit, e.g. an integrated circuit, designed for the respective functionality or also a programmable unit, such as a processor, programmed for the respective functionality.

In one embodiment of the invention, to reduce the transmission time lost due to transmission gaps, i.e. to increase the time which can be used for data transmission between the first base station **106** and the mobile terminal **103**, transmission gap patterns for different measurement types are defined in such a way that the transmission gaps of different measurements overlap. Further, according to an embodiment of the invention, for each measurement type the following parameters are specified:

a counter counting the number of measurements according to the measurement type that have been performed;



a parameter specifying the minimum number of measurements of the measurement type to be performed before reporting them to the base station;

a parameter specifying the relative priority of the measurement type, for example in the range of 1 to 8, in which the priority 1 specifies the highest priority and the priority 8 specifies the lowest priority.

The mobile terminal **103** carries out measurements of the measurement types using these parameters according to the following rules:

After each measurement of a measurement type the counter counting the number of measurements according to the measurement type that have been carried out, i.e. performed, is increased by the integer value 1. When the results of the measurements (e.g. performed since the previous reporting) of the measurement type are reported to the base station **103**, the counter is reset to a default value, for example 0.

When a transmission gap is specified for more than one measurement type, the mobile terminal **103** selects the measurement type of which a measurement is carried out during the transmission gap based on the counter counting the number of measurements according to the measurement type carried out, the minimum number of measurements according to the measurement type to be carried out before reporting and the relative priority of the measurement type. For example, this is done according to the following rule: A measurement of the measurement type which has the highest relative priority is selected to be carried out, or, in the case that more than one measurement type for which the transmission gap is specified have the highest priority, a measurement type is selected for which the counter counting the number of measurements carried out is smaller than the minimum number of measurements to be carried out before reporting.

The mobile terminal **103** only reports the measurements of that measurement type, i.e. the results of measurements of that measurement type, to the first base station **106**, for which the counter counting the number of the measurements carried out is equal or higher than the minimum number of measurements to be carried out before reporting.

The parameter specifying the minimum number of measurements to be carried out before reporting and the relative priority of the measurement type are for example signaled by the first radio access network **101** to the mobile terminal **103**, for example via a system information broadcast, or is signaled in course of the establishment of a dedicated communication connection between the mobile terminal **103** and the first base station **106**.

An example for the performing of measurements according to an embodiment of the invention is explained in the following with reference to FIG. 5.

FIG. 5 shows a transmission gap pattern **500** according to an embodiment of the invention.

As above, the transmission gap pattern **500** is illustrated in the form of a plurality of radio frames **501**, in this example in the form of a periodic frame cycle consisting of 12 radio

frames **501** numbered from 0 to 11. For example, a radio frame **501** has the structure as shown in FIG. 3 according to the LTE radio frame structure. Other frame structures are possible.

In this embodiment, the first radio access network **101**, for example an UMTS radio access network according to LTE, has configured parameters for the mobile terminal **103** for six types of measurements including inter frequency measurements as well as inter RAT measurements:

Type 1: Inter frequency LTE FDD: According to this measurement type, the reception power and/or reception quality of reference signals of different radio cells operated by the first radio access network **101** than the one operated by the first base station **106** is measured, for example the reference signals transmitted by the second base station **107**.

Type 2: Inter RAT UMTS CDMA FDD: The reception power and/or reception energy of the common pilot channel of the radio cells operated by a radio access network according to UMTS CDMA FDD are measured.

Type 3: Inter RAT GSM carrier RSSI: The received signal strength indicator (RSSI) of a GSM frequency carrier in a radio cell operated by a GSM radio access network, for example operated by the third base station **108** is measured.

Type 4: Inter RAT GSM initial BSIC identification: The reception power and/or reception quality of the frequency channel and the synchronization channel of radio cells operated by a GSM radio access network, for example operated by the third base station **108**, are measured.

Type 5: Inter RAT GSM BSIC re-confirmation: The reception power and/or reception quality of the synchronization channel of a radio cell operated by a GSM radio access network, for example operated by the third base station **108**, are measured.

Type 6: Inter RAT mobile WiMAX: The reception power and/or reception quality of the reference signal of radio cells operated according to a mobile WiMAX radio access network are measured.

In this example, it is assumed that the first radio access network **101** is operated in UMTS LTE FDD mode.

For each of the configured measurements the following parameters are specified the number of single measurements carried out ( $N_{mess}$ );

transmission gap length (TGL);

the minimum number of single measurements to be carried out before reporting ( $N_{mess\_min}$ );

the relative priority of the measurement.

Examples for the values of the parameters TGL,  $N_{mess\_min}$  and the (relative) priority are shown for the six measurement types in table 2.

TABLE 2

Parameter	Inter-Frequency FDD	UMTS CDMA FDD	GSM Carrier RSSI	GSM Initial BSIC identification	GSM BSIC re-confirmation	Mobile WiMAX
TGL (slots)	14	8	14	14	14	10
$N_{Mess Min}$	4	4	4	4	4	4
Priority	1	2	3	3	3	4

The transmission gap pattern includes a first transmission gap **502**, a second transmission gap **503** and a third transmission gap **504**. The first transmission gap **502** is specified for carrying out measurements of measurement types 1, 2 and 6, the second transmission gap **503** is specified for carrying out measurements according to measurement types 3 and 4 and the third transmission gap **504** is specified for carrying out measurements according to measurement type 5.



The first transmission gap **502** includes time slots of radio frames with numbers 0 and 1, the second transmission gap **503** includes time slots of radio frames with numbers 4 and 5 and the third transmission gap **504** includes time slots of radio frames with numbers 8 and 9. Illustratively, the transmission gaps for measurements of measurement types 1, 2 and 6 overlap and the transmission gaps for measurements of types 3 and 4 overlap.

For example, let at the beginning of the first transmission gap **502** the status of the measurements according to types 1, 2, 6 be:

Type 1:  $N_{mess}=6$

Type 2:  $N_{mess}=2$

Type 6:  $N_{mess}=3$ .

It is assumed that the mobile terminal **103** has only one receiver and that the measurement of each of the measurement types 1, 2 and 6 takes so much time that only one measurement of the types 1, 2 and 6 can be performed during the first transmission gap **502**. In this example, according to table 2, the priority of the measurement type 1 is the highest priority among the measurement types 1, 2, and 6 such that the mobile terminal **103** would, for example, choose to perform a measurement of measurement type 1. However, the mobile terminal **103** may take into account that for measurement type 1 the minimum number of measurement to be performed until reporting has already been reached and may choose to carry out a measurement according to measurement type 2 for which the minimum number of measurements to be carried out until reporting has not been reached and which has a higher priority than measurement type 6.

While the invention has been particularly shown and described with reference to specific embodiments, it should be understood by those skilled in the art that various changes in form and detail may be made therein without departing from the spirit and scope of the invention as defined by the appended claims. The scope of the invention is thus indicated by the appended claims and all changes which come within the meaning and range of equivalency of the claims are therefore intended to be embraced.

What is claimed is:

**1.** A method for performing measurements by a communication device, the method comprising:

selecting, for a time interval, at least two measurement types out of plurality of measurement types according to which measurements are to be performed, wherein the time interval is pre-defined as a transmission gap without signals being transmitted between the communication device and a first base station for carrying out measurements by communication device and that comprises a plurality of time slots in which a measurement of the selected measurement types may be performed; and performing a plurality of measurements of the selected at least two measurement types during the time interval.

**2.** The method according to claim **1**, wherein the communication device is a mobile terminal.

**3.** The method according to claim **1**, wherein the measurements are selected from a measurement of the reception quality of a signal sent by a base station in a radio cell and a measurement of the reception field strength of a signal sent by a base station in a radio cell.

**4.** The method according to claim **1**, further comprising: receiving a message specifying for each measurement type of the plurality of measurement types at least one time interval in which a measurement of the measurement type may be performed.

**5.** The method according to claim **1**, wherein each measurement type is assigned a priority and the at least one measurement type is selected based on the priorities of the measurement types.

**6.** The method according to claim **1**, wherein each measurement type is assigned a counter counting the number of measurements performed according to the measurement type and the at least one measurement type is selected based on the current values of the counters of the measurement types.

**7.** A method for scheduling measurements, the method comprising:

assigning a plurality of measurement types to a time interval that is defined as a transmission gap without signals being transmitted between a communication device and a first base station for carrying out measurements by the communication device; and

signaling the assignment to the communication device, wherein each measurement type is assigned a priority and a counter counting the number of measurements performed according to the measurement type, and at least one measurement type is selected based on the priorities of the measurement types and/or the current values of the counters of the measurement types.

**8.** A communication network circuit comprising:

an assigning circuit configured to assign a plurality of measurement types to a time interval that is defined as a transmission gap without signals being transmitted between a communication device and a first base station for carrying out measurements by the communication device; and

a signaling circuit configured to signal the assignment to the communication device, wherein each measurement type is assigned a priority and a counter counting the number of measurements performed according to the measurement type, and at least one measurement type is selected based on the priorities of the measurement types and/or the current values of the counters of the measurement types.

**9.** A communication device, comprising:

a selecting circuit configured to select, for a time interval, at least two measurement types out of plurality of measurement types according to which measurements are to be performed, wherein the time interval is pre-defined as a transmission gap without signals being transmitted between the communication device and a first base station for carrying out measurements by the communication device and that comprises a plurality of time slots in which a measurement of the selected measurement types may be performed; and

a measurement circuit configured to perform a plurality of measurements of the selected at least two measurement types during the time interval.

**10.** The communication device according to claim **9**, further comprising:

a receiving circuit configured to receive a message specifying for each measurement type of the plurality of measurement types at least one time interval in which a measurement of the measurement type may be performed.

**11.** The communication device according to claim **9**, wherein the communication device is a mobile terminal.

**12.** The communication device according to claim **11**, wherein the mobile terminal is a mobile terminal according to UMTS.

**13.** The communication device according to claim **9**, wherein the measurements are selected from a measurement of the reception quality of a signal sent by a base station in a

radio cell and a measurement of the reception field strength of a signal sent by a base station in a radio cell.

14. The communication device according to claim 9, wherein each measurement type is assigned a priority and the at least one measurement type is selected based on the priorities of the measurement types. 5

15. The communication device according to claim 9, wherein each measurement type is assigned a counter counting the number of measurements performed according to the measurement type and the at least one measurement type is selected based on the current values of the counters of the measurement types. 10

16. A method for configuring measurements by a communication device, the method comprising: receiving a message that includes an assignment of a plurality of measurement types according to which measurements are to be performed to a time interval that is defined as a transmission without signals being transmitted between a communication device and a first base station for carrying out measurements by the communication device; and selecting, for a time interval, at least two measurement types out of plurality of measurement types. 15 20

\* \* \* \* \*