



US009271026B2

(12) **United States Patent**
Olson et al.

(10) **Patent No.:** **US 9,271,026 B2**
(45) **Date of Patent:** ***Feb. 23, 2016**

(54) **DYNAMICALLY CONFIGURABLE
FREQUENCY BAND SELECTION DEVICE
BETWEEN CATV DISTRIBUTION SYSTEM
AND CATV USER**

(58) **Field of Classification Search**
CPC H04N 21/4104; H04N 21/6168; H04N
21/643; H04N 7/102; H04N 12/2801
USPC 725/118, 149, 128-129; 370/280, 464;
455/127, 3.01, 3.06
See application file for complete search history.

(71) Applicant: **PPC Broadband, Inc.**, East Syracuse,
NY (US)

(72) Inventors: **Thomas A. Olson**, Maryville, TN (US);
David Kelma, Madisonville, TN (US);
Joseph Lai, Los Angeles, CA (US);
Steven K. Shafer, Chittenango, NY
(US)

(56) **References Cited**

U.S. PATENT DOCUMENTS

3,790,909 A 2/1974 Le Fevre
4,418,424 A 11/1983 Kawamoto et al.

(Continued)

(73) Assignee: **PPC BROADBAND, INC.**, East
Syracuse, NY (US)

FOREIGN PATENT DOCUMENTS

(*) Notice: Subject to any disclaimer, the term of this
patent is extended or adjusted under 35
U.S.C. 154(b) by 0 days.

CN 101094375 A 12/2007
JP 55080989 A 8/1980

(Continued)

This patent is subject to a terminal dis-
claimer.

Primary Examiner — Brian T Pendleton

Assistant Examiner — Alan Luong

(74) *Attorney, Agent, or Firm* — MH2 Technology Law
Group, LLP

(21) Appl. No.: **14/337,424**

(22) Filed: **Jul. 22, 2014**

(65) **Prior Publication Data**

US 2014/0331270 A1 Nov. 6, 2014

Related U.S. Application Data

(63) Continuation of application No. 12/252,907, filed on
Oct. 16, 2008, now Pat. No. 8,832,767.

(51) **Int. Cl.**
H04N 7/16 (2011.01)
H04N 21/41 (2011.01)

(Continued)

(52) **U.S. Cl.**
CPC **H04N 21/4104** (2013.01); **H04L 12/2801**
(2013.01); **H04N 7/102** (2013.01); **H04N**
21/6168 (2013.01); **H04N 21/643** (2013.01)

(57) **ABSTRACT**

A frequency band selection device that can be inserted into a signal transmission line of a CATV system on the premise of a user includes at least two signal path sets between a tap side and a premise side. Each signal path set includes two discrete signal paths, a high frequency signal path for a downstream bandwidth and a low frequency signal path for an upstream bandwidth. The high frequency signal path and the low frequency signal path are separated by a cut-off transition frequency that is different for each signal path set. The device further includes a switch controller having at least two discrete switch positions. The switch controller chooses one of the switch positions as a result of an information signal. Each of the switch positions corresponds to a respective one of the signal path sets.

12 Claims, 11 Drawing Sheets

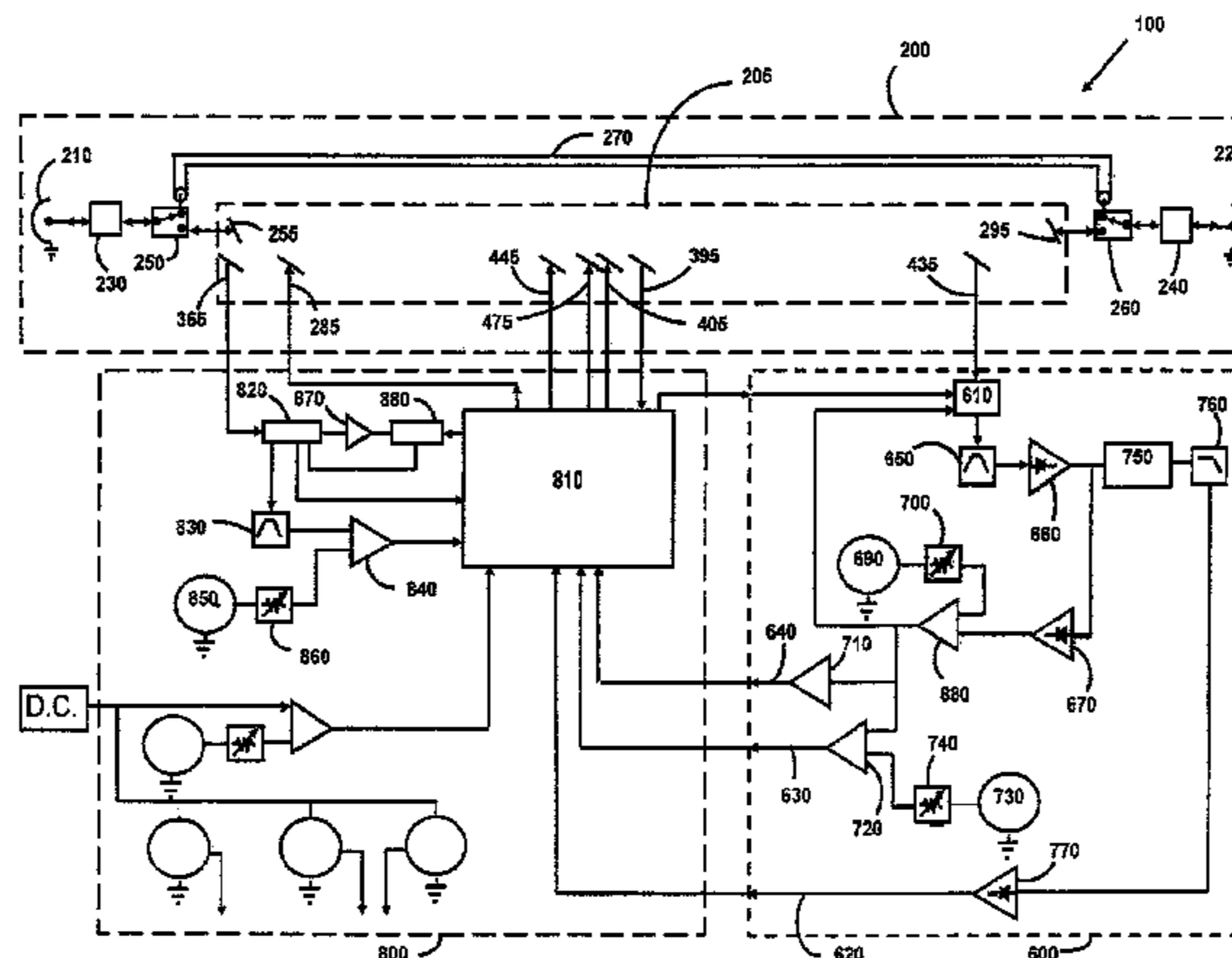

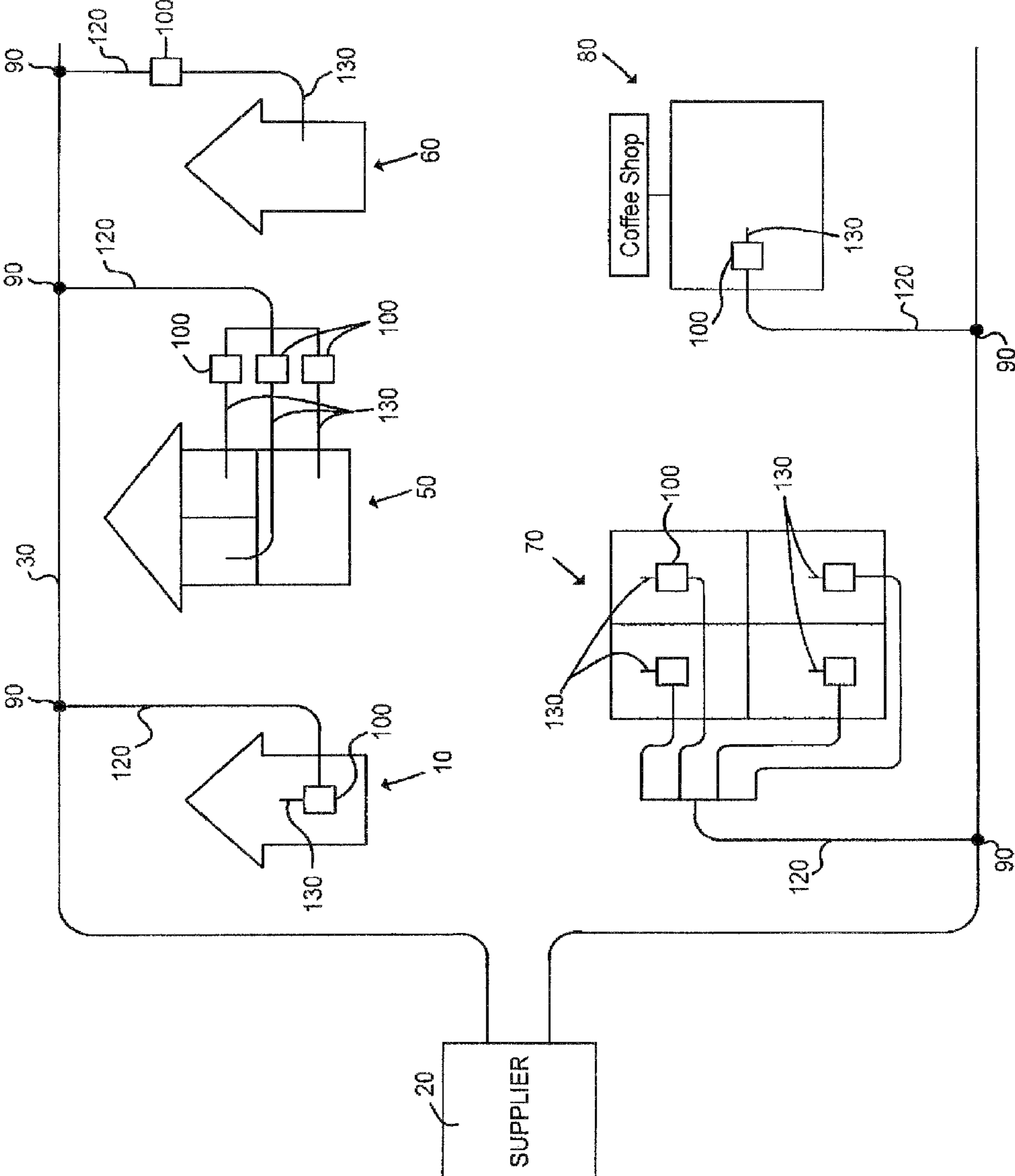

FIG. 1

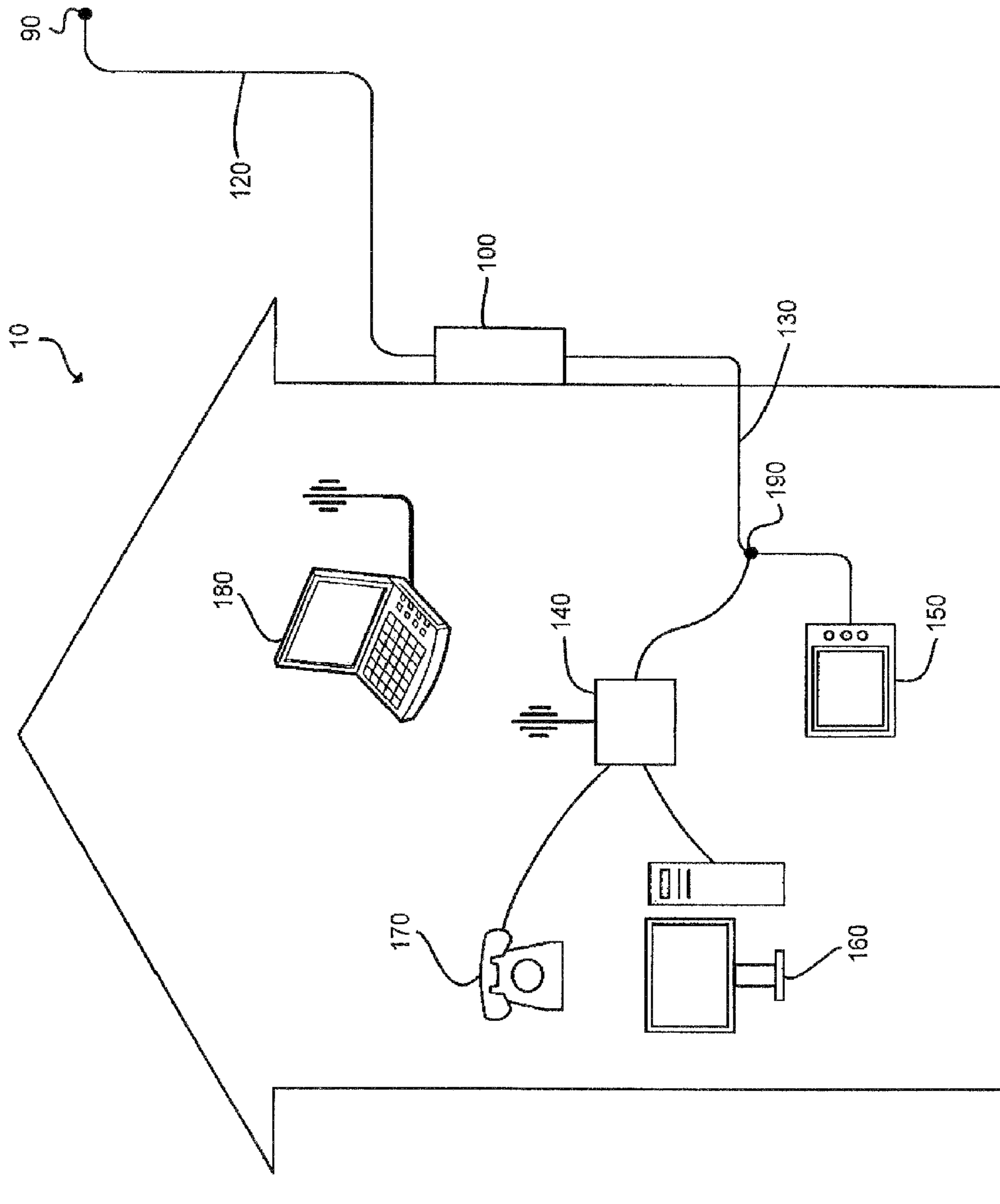

FIG. 2

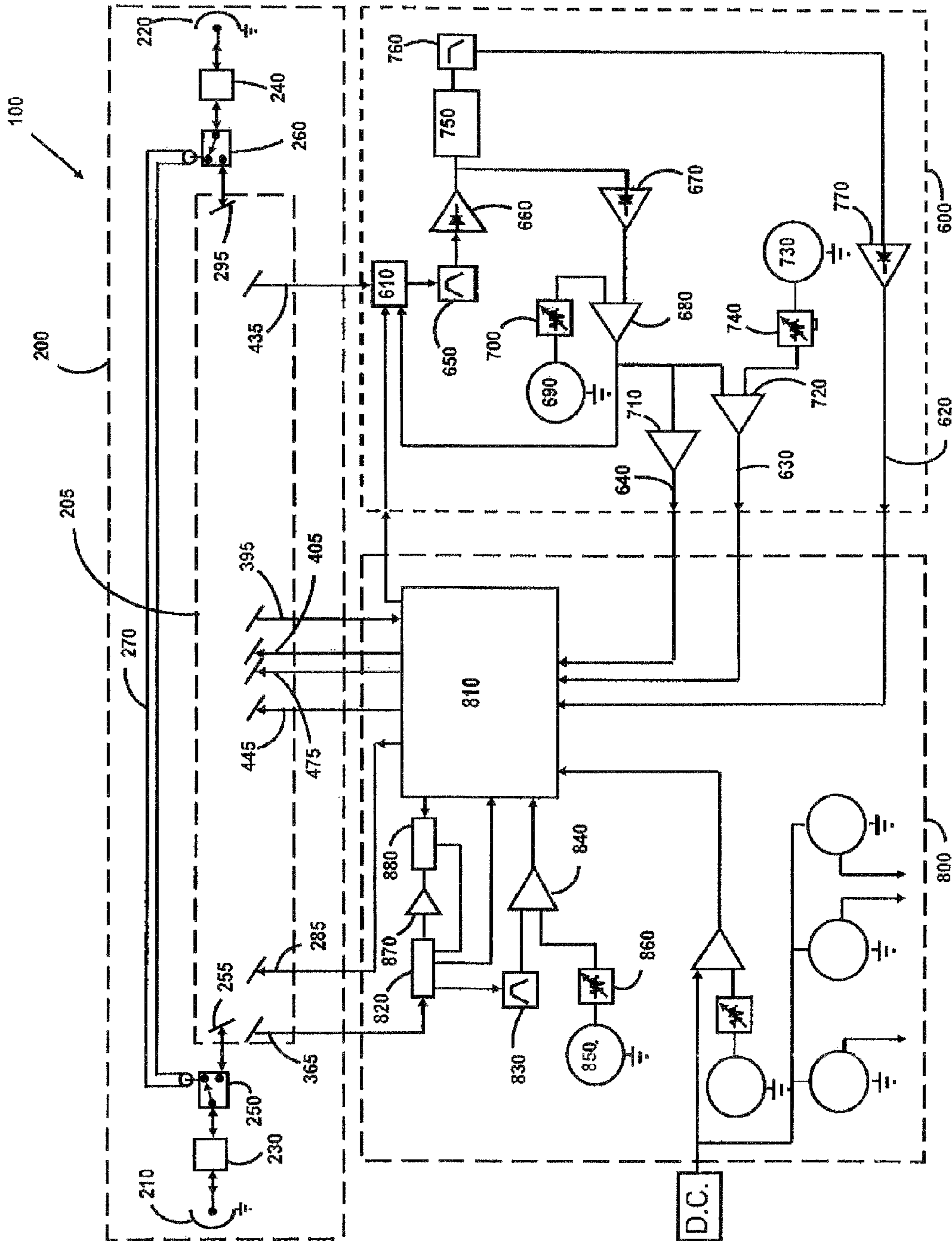

FIG. 3

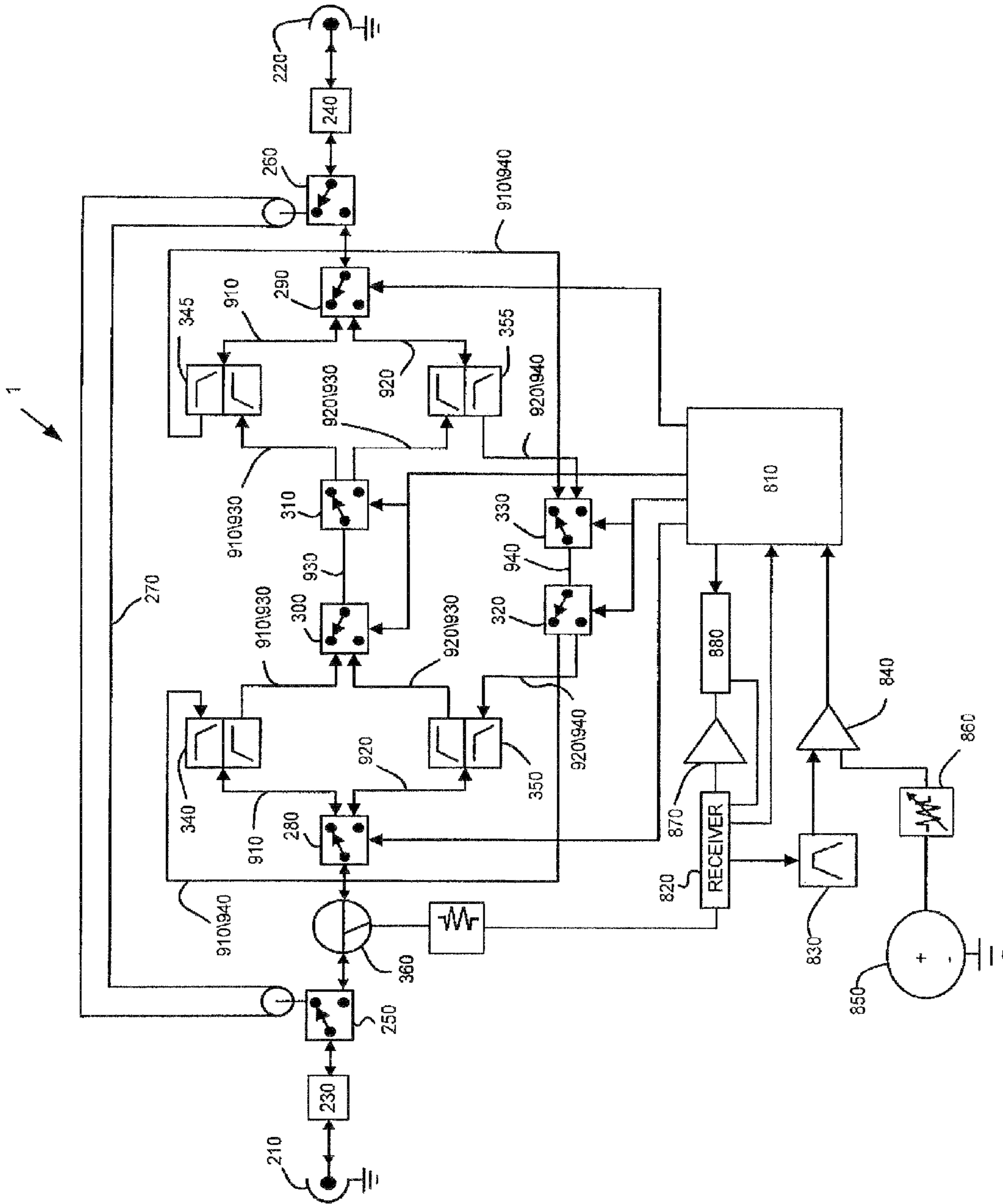

FIG. 5

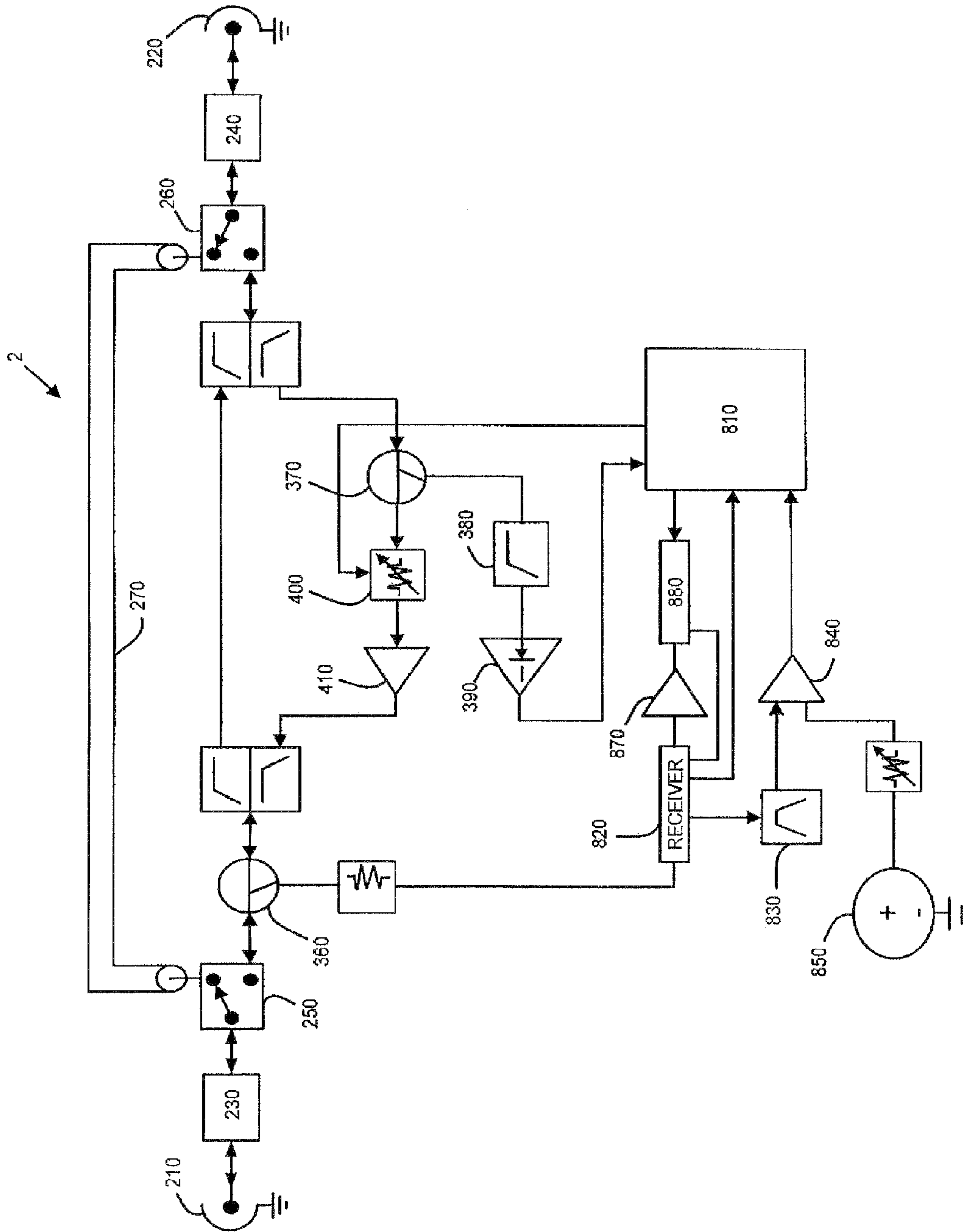

FIG. 6a

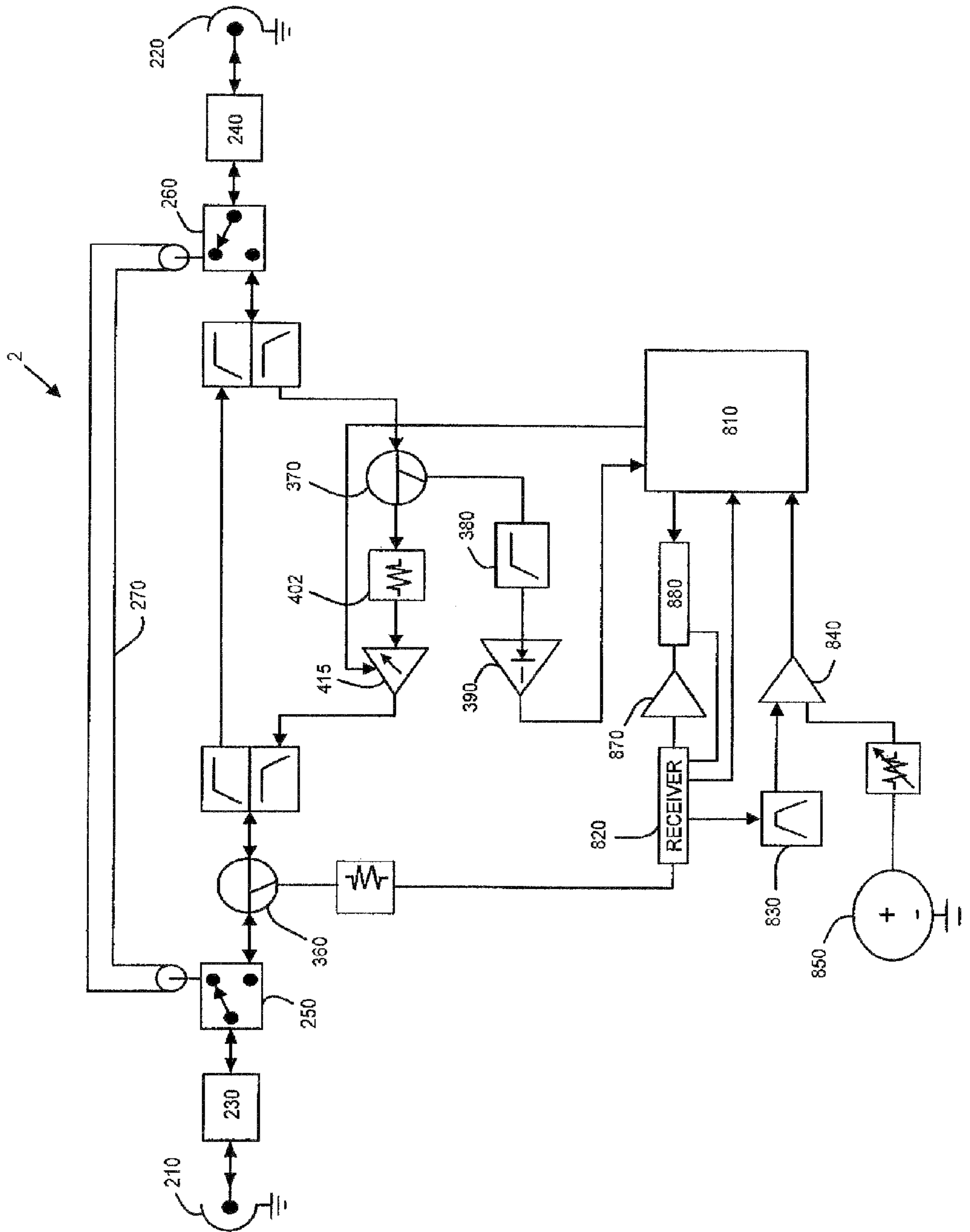

FIG. 6b

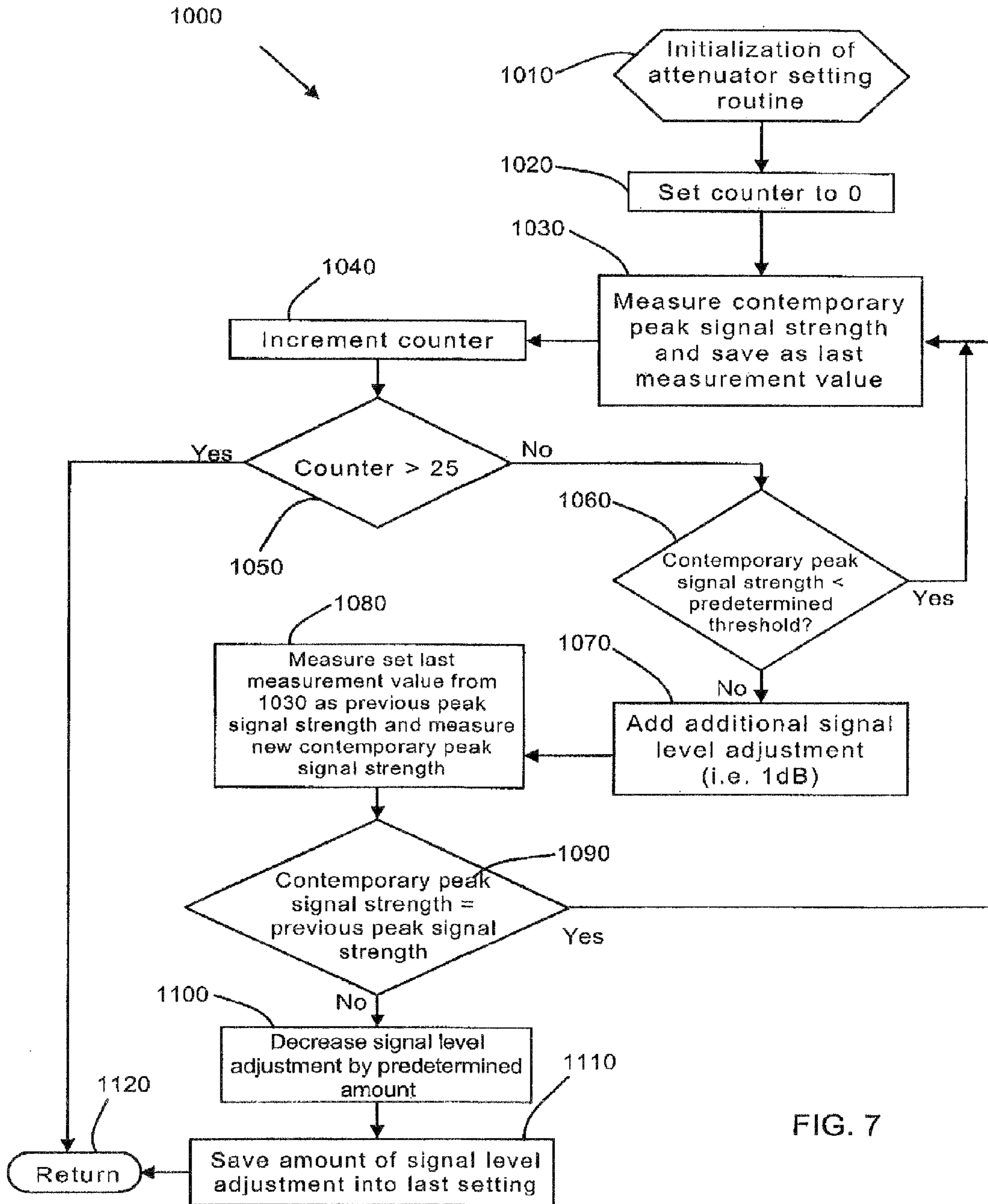

FIG. 7

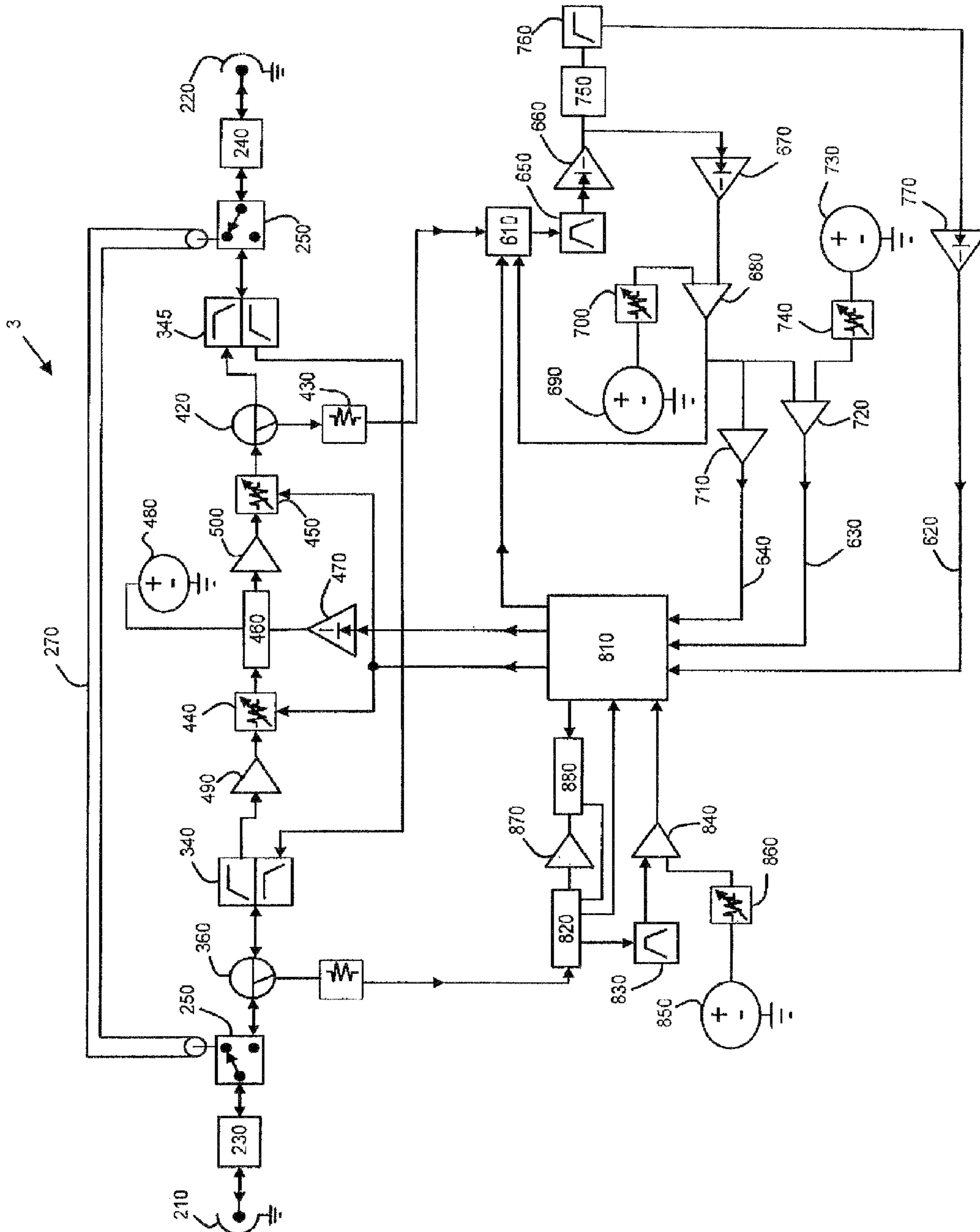

FIG. 8

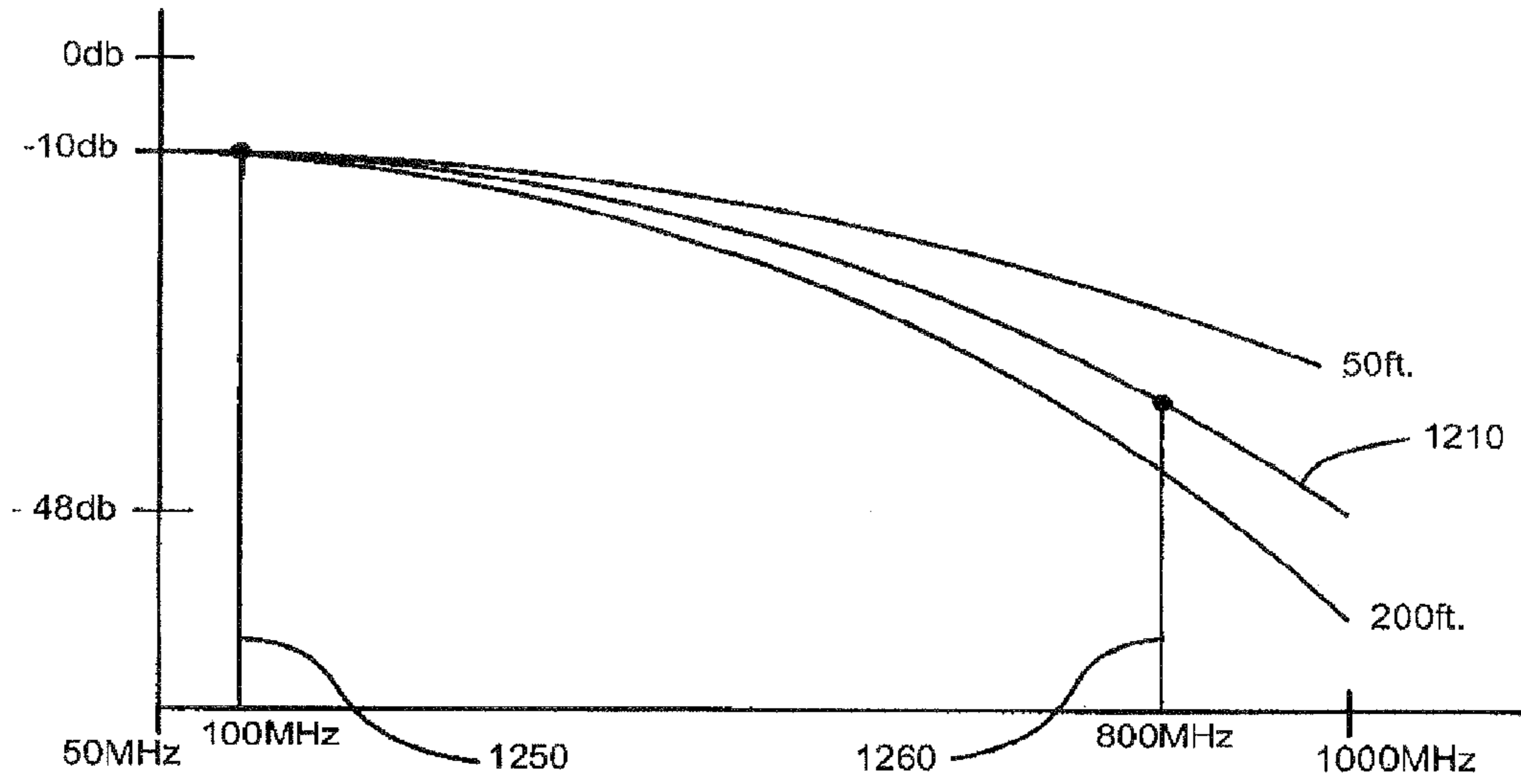

FIG. 9

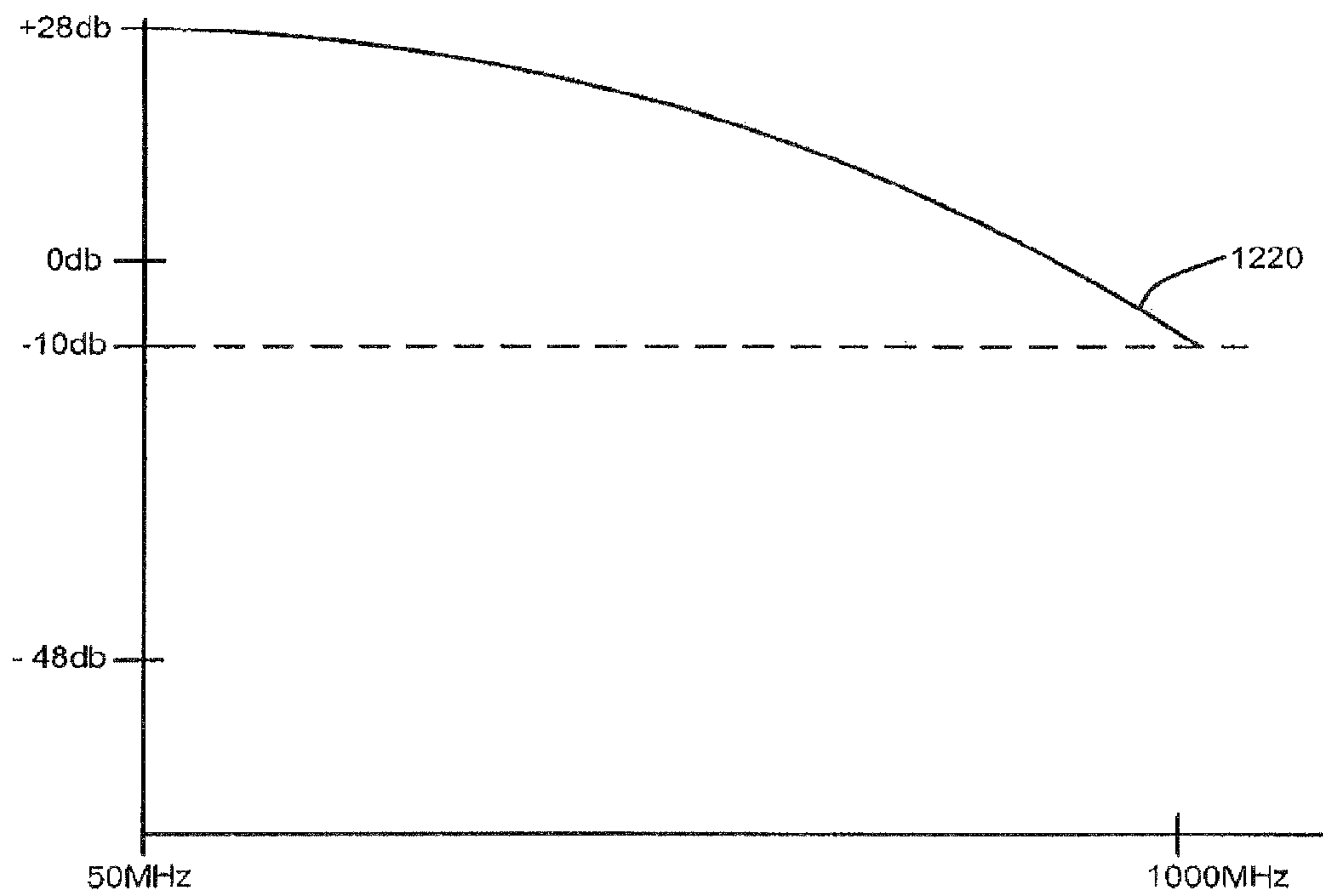

FIG. 10

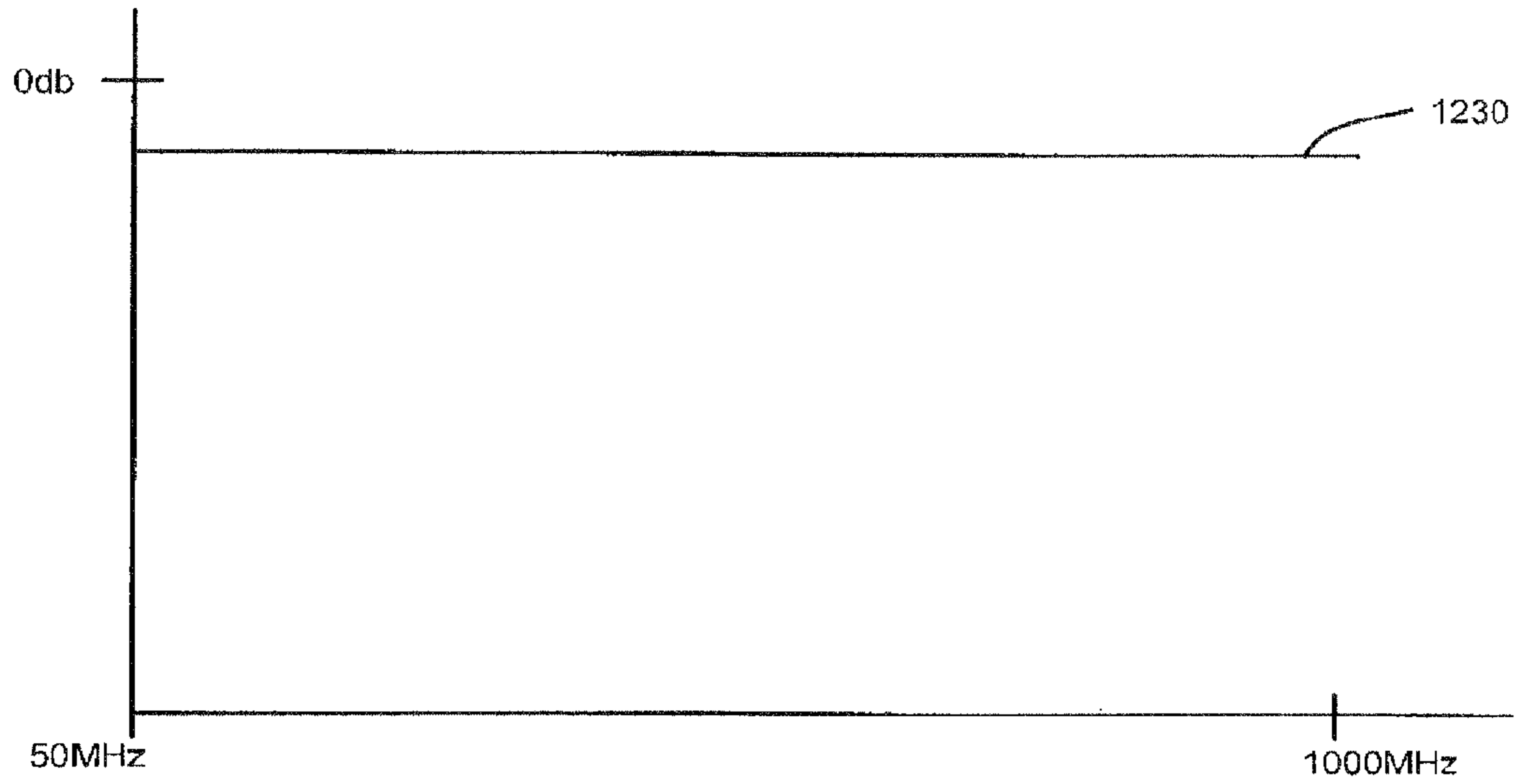

FIG. 11

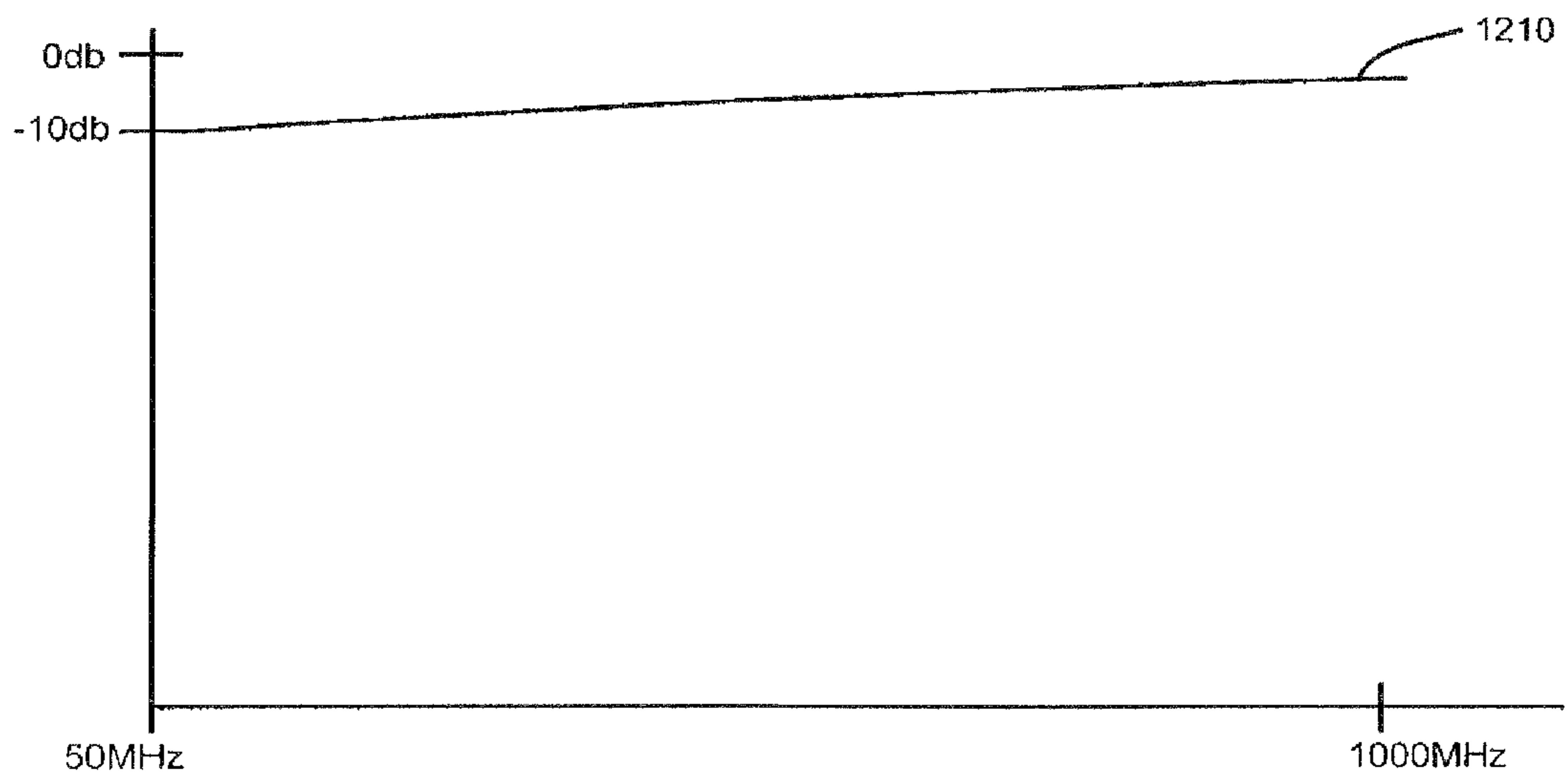

FIG. 12

1

**DYNAMICALLY CONFIGURABLE
FREQUENCY BAND SELECTION DEVICE
BETWEEN CATV DISTRIBUTION SYSTEM
AND CATV USER**

CROSS-REFERENCE TO RELATED
APPLICATION

This application is a continuation of, and claims the benefit and priority of, U.S. patent application Ser. No. 12/252,907, filed on Oct. 16, 2008. The entire contents of which are hereby incorporated by reference.

BACKGROUND OF THE INVENTION

The use of a cable television (“CATV”) system to provide internet, voice over internet protocol (“VOIP”) telephone, television, and radio services is well known in the art. In providing these services, a downstream bandwidth (i.e., radio frequency (“RF”) signals, digital signals, optical signals, etc.) is passed from a supplier of the services to a user and an upstream bandwidth is passed from the user to the supplier. The downstream bandwidth is passed, for example, within relatively higher frequencies from within a total bandwidth of the CATV system while the upstream bandwidth is passed within relatively lower frequencies.

Traditionally, the size of the downstream bandwidth far exceeds the size of the upstream bandwidth due to nature of the services provided. For example, while the downstream bandwidth must accommodate all of the television and radio programming along with internet and VOIP downloading, the upstream bandwidth is only required to accommodate internet, system control signals, and VOIP uploading. Problems are arising, however, due to an increase in upstream bandwidth usage caused by an increasing demand for higher speed internet uploads and the increasing demand for the VOIP telephone services.

VOIP telephone services places significant demands on the upstream bandwidth. When a user uploads a large image file to a photo sharing website, the image file will be parsed into a number of data packets that can be intermixed with other data packets being passed through a particular portion of the upstream bandwidth by other users located on a particular signal transmission line within the CATV system. To optimize a total data throughput on the particular signal transmission line, the data packets may be significantly delayed and/or reorganized without any knowledge of or inconvenience to the user. When a user uses VOIP telephone services, their voice is converted into data packets that are similar in form to the data packets used to upload the image file. Because a typical conversation is carried out in real time, meaning that a contiguous and unbroken flow of data packets is required, any person with whom the user is talking will quickly notice significant delays in the delivery of the data packets and/or reorganization of the data packets that results in audio distortion of the user’s voice. Any such reorganization and/or delay in the uploading of data packets carrying VOIP telephone services are measured in terms of jitter, and are closely monitored because of the significant service quality characteristics it represents.

Jitter experienced between the user and their caller is a direct result of network congestion within the upstream bandwidth. Because the upstream bandwidth is shared by all users on the particular signal transmission line, each user is competing with the other users for packet data space within the upstream bandwidth. Even further, each of the users can unknowingly inject interference signals, such as noise, spu-

2

rious signals, and other undesirable signals, into the upstream bandwidth through the use of common household items and poor quality wiring in the user’s premise, the interference signals causing errors that force a slow down and an additional amount of jitter in the upstream flow of packets.

In an effort to increase the upstream flow of packets, several suppliers have a plan to increase the size of the upstream bandwidth from 5-42 Mhz to 5-85 Mhz to allow a greater flow of the upstream content. Along with such an increase, the downstream bandwidth must be correspondingly decreased in size because the total bandwidth is relatively fixed. Such a change is, however, very difficult to implement.

Traditional practices would require that every drop amplifier and two way (diplex) filter in network amplifiers and nodes of the CATV system to be changed as part of the increasing the size of the upstream bandwidth. Compounding the difficulty of implementing such a change, all of the changes must be implemented at various locations throughout the CATV system at a single, particular time. Accordingly, such an implementation is time consuming, costly, and difficult to coordinate.

Further, while increasing the size of the upstream bandwidth may incrementally increase the flow of upstream data packets, the upstream bandwidth remains susceptible to reliability/congestion issues since it is based on an inherent, system wide flaw that leaves the upstream bandwidth open and easily impacted by any single user. For example, while the downstream bandwidth is constantly monitored and serviced by skilled network engineers, the upstream bandwidth is created and passed using an infrastructure within a user’s premise that is maintained by the user without the skill or knowledge required to reduce the creation and passage of interference signals into the upstream bandwidth. This issue is further compounded by the fact that over 500 premises can be connected together such that interference signals generated by one of the 500 premises can easily impact all of the remaining premises. It is common in the art for the supplier to add physical filters between the user’s premise and a tap from of the main signal distribution system near the users premise to reduce the impact of the interference signals generated on the user’s premise, but such a physical filter must be installed manually and does not account for significant, transient interference sources such as garbage disposals, vacuum cleaners, welders, powered hand tools, etc.

Even further, increasing the size of the upstream bandwidth forces suppliers to push their downstream content into increasingly higher frequency portions of the downstream bandwidth. Unfortunately, these higher frequencies are much more susceptible to parasitic losses in signal strength caused by the signal transmission lines, connectors on the user’s premise, devices connected to the signal transmission lines on the user’s premise, etc. In the past many users have added relatively low-tech drop amplifiers on their premise to account for such losses. Because of the changes to increase the size of the upstream bandwidth, all of these drop amplifiers must be removed and or replaced. Additionally, because of the increased demands placed on the downstream content (e.g., high definition television, increased compression, etc.) the signal strength (i.e., level) of the downstream bandwidth must be maintained to closer tolerances than can typically be provided by the typical low-tech drop amplifier. Accordingly, as a result of increasing the size of the upstream bandwidth, the quality of the content moved to the higher frequencies within the downstream bandwidth may be significantly lessened causing a decrease in customer satisfaction and an increase in costly service calls.

In light of the forgoing, increasing the size of the upstream bandwidth: (i) may require a significant amount of capital expenditure in terms new filter devices and the manpower to install the devices; (ii) may not result in the expected large increases in upstream data throughput because of the interference signals injected from within each user's premise; (iii) may result in lower quality downstream content, and (iv) may inject additional interference signals that now fall within the additional upstream bandwidth, which would have otherwise been filtered out.

Therefore, there is a need to overcome, or otherwise lessen the effects of, the disadvantages and shortcomings described above.

SUMMARY OF THE INVENTION

The present invention helps to reduce the complexity and cost involved with changing the size of an upstream bandwidth. Specifically, the present invention allows a CATV supplier to implement such a change in the size at a common, specific time to all users of the CATV services.

Further, the present invention can be added to a variety of other devices that require a defined separation between the upstream bandwidth and the downstream bandwidth. The incorporation of the present invention allows such other devices to remain relevant after a change in the size of the upstream bandwidth.

In accordance with one embodiment of the present invention, a frequency band selection device is provided that can be inserted into a signal transmission line of a CATV system on the premise of a user. The device includes at least two signal path sets between a tap side and a premise side. Each signal path set includes two discrete signal paths, a high frequency signal path allowing a downstream bandwidth to pass from the tap side to the premise side and a low frequency signal path allowing an upstream bandwidth to pass from the premise side to the tap side. The high frequency signal path and the low frequency signal path are separated by a cut-off transition frequency that is different for each signal path set. The device further includes a switch controller having at least two discrete switch positions. The switch controller chooses one of the switch positions as a result of an information signal. Each of the switch positions corresponds to a respective one of the signal path sets.

In accordance with one embodiment of the present invention, a dynamically configurable CATV system is provided. The system includes a plurality of frequency band selection devices, each of the devices being located on a premise of a user. Each device includes at least two signal path sets between a tap side and a premise side. Each signal path set includes two discrete signal paths, a high frequency signal path allowing a downstream bandwidth to pass from the tap side to the premise side and a low frequency signal path allowing an upstream bandwidth to pass from the premise side to the tap side. The high frequency signal path and the low frequency signal path are separated by a cut-off transition frequency that is different for each signal path set. Each device further includes a switch controller having at least two discrete switch positions. The switch controller chooses one of the switch positions as a result of an information signal. Each of the switch positions corresponds to a respective one of the signal path sets. The system further includes a head end transmitter being connected to each of the plurality of devices via a main distribution line, the head end transmitter providing the information signal to the switch controller in each of the devices.

In accordance with one embodiment of the present invention, a method is provided for varying CATV frequency bands on a premise of a user of CATV services. The method includes providing a frequency band selection device on the premise. The device includes at least two signal path sets between a tap side and a premise side. Each signal path set includes two discrete signal paths, a high frequency signal path allowing a downstream bandwidth to pass from the tap side to the premise side and a low frequency signal path allowing an upstream bandwidth to pass from the premise side to the tap side. The high frequency signal path and the low frequency signal path are separated by a cut-off transition frequency that is different for each signal path set. The device further includes a switch controller having at least two discrete switch positions. The switch controller chooses one of the switch positions as a result of an information signal. Each of the switch positions corresponds to a respective one of the signal path sets. The method further includes actuating the switch controller as a result of the information signal.

In accordance with one embodiment of the present invention, the device further includes a tap side filter set including at least two frequency band splitting devices selectable by a tap side switch set, and a premise side filter set including at least two frequency band splitting devices selectable by a premise side switch set. Preferably, the tap side switch set and the premise side switch set are actuated by the switch controller.

In accordance with one embodiment of the present invention, the tap side switch set includes a tap side downstream switch and a tap side upstream switch, and the premise side switch set includes a premise side downstream switch and a premise side upstream switch.

In accordance with one embodiment of the present invention, the information signal is a continuous tone.

In accordance with one embodiment of the present invention, the information signal contains a coded operational signal.

In accordance with one embodiment of the present invention, one of the frequency band splitting devices in each of the tap side filter set and the premise side filter set is configured to separate the upstream bandwidth from the downstream bandwidth according to DOCSIS-1 and DOCSIS-2 standards.

In accordance with one embodiment of the present invention, one of the frequency band splitting devices in each of the tap side filter set and the premise side filter set is configured to separate the upstream bandwidth from the downstream bandwidth according to a DOCSIS-3 standard.

In accordance with one embodiment of the present invention, the device includes three or more signal path sets and three or more discrete switch positions.

BRIEF DESCRIPTION OF THE DRAWINGS

For a further understanding of the nature and objects of the invention, references should be made to the following detailed description of a preferred mode of practicing the invention, read in connection with the accompanying drawings in which:

FIG. 1 is a graphical representation of a CATV system arranged in accordance with an embodiment of the present invention;

FIG. 2 is a graphical representation of a user's premise arranged in accordance with an embodiment of the present invention;

FIG. 3 is a partial circuit diagram of a premise device made in accordance with an embodiment of the present invention;

5

FIG. 4 is a partial circuit diagram of the premise device represented in FIG. 3;

FIG. 5 is a circuit diagram representing a premise device including a configurable frequency band selection device made in accordance with another embodiment of the present invention;

FIG. 6a is a circuit diagram representing a premise device including an upstream bandwidth conditioning device made in accordance with another embodiment of the present invention;

FIG. 6b is a circuit diagram representing a premise device including an upstream bandwidth conditioning device made in accordance with another embodiment of the present invention;

FIG. 7 is a flow chart representing an signal level adjustment setting routine performed by the circuit of FIGS. 6a and 6b;

FIG. 8 is a circuit diagram representing a premise device including an automatic downstream bandwidth output level and/or output level tilt compensation device made in accordance with another embodiment of the present invention; (NOTE: manually inserted compensation devices have been common for years)

FIG. 9 is a graphical representation of an interpolated gain curve determined in accordance with the device represented in FIG. 8.

FIG. 10 is a graphical representation of a gain curve determined in accordance with the device represented in FIG. 8;

FIG. 11 is a graphical representation of a gain curve determined in accordance with the device represented in FIG. 8;

FIG. 12 is a graphical representation of a gain curve determined in accordance with the device represented in FIG. 8.

DETAILED DESCRIPTION OF THE INVENTION

As shown in FIG. 1, a cable television (“CATV”) system typically includes a supplier 20 that transmits downstream signals, such as radio frequency (“RF”) signals, digital signals, optical signals, etc., to a user through a main signal distribution system 30 and receives upstream signals from a user through the same main signal distribution system 30. A tap 90 is located at the main signal distribution system 30 to allow for the passage of the downstream/upstream signals from/to the main signal distribution system 30. A drop transmission line 120 is then used to connect the tap 90 to a house 10, 60, an apartment building 50, 70, a coffee shop 80, and so on. A premise device 100 of the present invention is connected in series or in parallel between the drop transmission line 120 and a user’s premise distribution system 130.

Referring still to FIG. 1, it should be understood that the premise device 100 can be placed at any location between the tap 90 and the user’s premise distribution system 130. This location can be conveniently located within the building 10, or exterior to the building 60. Similarly, the premise device 100 can be located within individual apartments of the apartment building 70 or exterior to the apartment building 50. It should be understood that the premise device 100 can be placed at any location, such as the coffee shop 80 or other business, where CATV services, including internet, VOIP, or other unidirectional/bidirectional services are being used.

As shown in FIG. 2, the user’s premise distribution system 130 can then be split using a splitter 190 so that upstream/downstream signals can pass to a television 150 and a modem 140 in accordance with practices well known in the art. The modem 140 can include voice over internet protocol (“VOIP”) capabilities affording telephone 170 services and

6

can include a router affording internet services to a desktop computer 160 and a laptop computer 180, for example.

Additionally, it is common practice to provide a “set-top box” (“STB”) or “set-top unit” (“STU”) for use directly with the television 150. For the sake of clarity, however, there is no representation of an STB or STU included in FIG. 2. The STB and STU are mentioned here in light of the fact that many models utilize the upstream bandwidth to transmit information relating to “pay-per-view” purchases, billing, etc. Accordingly, it should be understood that even though FIG. 2 explicitly shows that there is only one premise device 100 used for each device generating upstream data packets, each premises device 100 can be used with two or more devices (e.g. a modem, a STB, a STU, a dedicated VOIP server, etc.) that transmit upstream data packets via the upstream bandwidth.

Referring to FIG. 3, the premise device 100 includes a main circuit 200 that is positioned along with a tuner circuit 600 and a microprocessor circuit 800. Preferably, the combination of circuits 200, 600, 800 forms a configurable frequency band selection device 1 (represented separately in FIG. 5), an upstream bandwidth conditioning device 2 (represented separately in FIGS. 6a and 6b) and a downstream output level and/or output level tilt compensation device 3 (represented separately in FIG. 8), each of which will be discussed separately in greater detail below. It should be understood, however, that circuits 200, 600, 800 of the premise device 100 can be configured to form any combination of the devices such that the premise device 100 may include any one of the devices, any two the devices, or all three of the devices. Preferably, each of the circuits are positioned within a single enclosure, but it should be understood that circuits 200, 600, 800 could be arranged within multiple enclosures to account for space, cost, better resultant performance, or other environmental considerations.

Because a diagram of a premise device 100 including all three devices is too complex to be clearly represented in one figure, a circuit 205 of the main circuit 200, as it is represented in FIG. 3, is represented in FIG. 4 with inputs and outputs between itself and the remaining positions of the circuit 200 in FIG. 3 labeled similarly.

Along these lines, alternate embodiments of the premise device 100 are represented in FIGS. 5, 6a, 6b and 8. FIG. 5 represents an embodiment of the premise device 100 including only the configurable frequency band selection device 1. FIGS. 6a and 6b represent an embodiment of the premise device 100 including only the upstream bandwidth conditioning device 2. FIG. 8 represents an embodiment of the premise device 100 including only the downstream output level and/or output level tilt compensation device 3. It should be understood that the embodiments shown in FIGS. 5, 6a, 6b and 8 are presented to help clarify the components specific to the particular device, and that other embodiments including combinations of these are envisioned.

Individual components that are similar between the embodiments represented in FIGS. 3, 4, 5, 6a, 6b, and 8 are identified using the similar reference numbers. For example, the microprocessor represented in each of the embodiments is referenced using the number 810. One skilled in the art should know that the microprocessor could be the same or different across the embodiments depending on the requirements placed thereon.

As shown in FIG. 3, the main circuit 200 of the premise device 100 includes a supplier side 210 and a premise side 220. The supplier side 210 is positioned to receive the downstream bandwidth from the supplier 20 (FIG. 1) and to send the upstream bandwidth to the supplier 20. The premise side

220 is positioned to send the downstream bandwidth to the user and to receive the upstream bandwidth from the user. Each of the supplier side 210 and the premise side 220 can include a traditional threaded 75 ohm connector so that the premise device 100 can be easily placed in series with the drop transmission line 120 and the premise distribution system 130. Alternatively, each of the supplier side 210 and the premise side 220 may include a proprietary connector to hinder attempts at tampering with or theft of the premise device 100. Other connectors may also be used depending on the type and/or size of the drop transmission line 120, the premise distribution system 130, or a system impedance other than 75 ohms.

The premise device 100 preferably includes a lightning protection device 230 positioned near the supplier side 210 and a lightning protection device 240 positioned near the premise side 220. Having two lightning protection devices 230, 240 attempts to protect the premise device 100 from energy passing from the drop transmission line 120 from a lightning strike and from energy passing from the premise distribution system 130 from a lightning strike. It should be understood that the lightning protection devices may not be necessary if/when the premise device 100 is configured to be placed in a CATV system that utilizes non-conductive signal transmission lines. Any of the high quality, commercially available lightning protection devices will function well within the specified locations within the premise device 100.

The premise device 100 preferably includes two power bypass failure switches 250, 260 that route all of the upstream/downstream signals through a bypass signal path 270 (e.g. a coaxial cable, an optical cable, a microstrip, a stripline, etc.) in the event of a power outage. The bypass failure switches 250, 260 are preferably located near the supplier end 210 and premise end 220, respectively. In an effort to protect the bypass failure switches 250, 260 from damage due to lightning energy, they are preferably placed between the lightning protection devices 230, 240 and the supplier end 210 and premise end 220.

Each of the bypass failure switches 250, 260 includes a default position bypassing the upstream/downstream signals through the bypass signal path 270 at any time power is removed from the premise device 100. When power is applied, each of the bypass failure switches 250, 260 actuate to a second position that disconnects the bypass signal path 270 and passes all of the upstream/downstream signal transmissions along another path through the circuit 205 (FIG. 4) within the main circuit 200. The switches may also be controlled such that when there is a fault detected in the premise device 100 that could abnormally hinder the flow of the upstream/downstream bandwidths through the circuit 205 (FIG. 4), the switches 250, 260 are moved to their default position sending the upstream/downstream signal transmissions through the bypass signal path 270. Any of the high quality, commercially available signal transmission switches will function well within the specified locations within the premise device 100. The bypass signal path 270 can be any suitable coaxial cable or optical cable depending on the CATV system configuration.

The premise device 100 preferably includes circuit components creating the frequency band selection device 1 (FIG. 5 and represented but not referenced in FIGS. 3 and 4). The frequency band selection device 1 is configured to automatically switch between a configuration corresponding to earlier Data Over Cable Service Interface Specification ("DOCSIS") specifications and a configuration corresponding to a later generation specification, such as DOCSIS 3.0. While this feature may be advantageous by itself in the premise device

100, this feature allows for other devices, such as the upstream bandwidth conditioning device 2 and the downstream bandwidth output level and/or output level tilt compensation device 3, to remain relevant after a change between specifications. In particular, because each of these devices requires an accurate separation of signals between the upstream bandwidth and the downstream bandwidth, any necessary change in the upstream/downstream bandwidths would render these specific devices inoperable. It should be understood that even though the DOCSIS specifications are referenced above and below, the upstream/downstream bandwidth configurations may be maintained and changed according to any specifications.

A simplified version of the of the frequency band selection device 1 is shown in FIG. 5 while all of the components are also present in the embodiment of FIGS. 3 and 4. The selection device 1 includes a plurality of switches 280, 290, 300, 310, 320, 330 that define a first signal path set 910 and second signal path set 920. Each signal path set includes two discrete signal paths, a high frequency signal path 930 and a low frequency signal path 940. The first signal path set 910 is formed using a pair of first frequency band splitting devices 340, 345, and the second signal path set 920 is formed using a pair of second frequency band splitting device 350, 355. A cutoff frequency set by the first pair of frequency band splitting devices 340, 345 corresponds to DOCSIS specifications having a narrower upstream bandwidth, and a cutoff frequency set by the second set pair of frequency band splitting devices 350, 355 corresponds to the later DOCSIS specifications, which include a broader upstream bandwidth than the earlier DOCSIS standards. It should be understood that the cutoff frequencies can be changed to accommodate even newer DOCSIS standards or other standards by the mere replacement of the first pair of frequency band splitting devices 340, 345 and/or the second pair of frequency band splitting devices 350, 355. Any of the high quality, commercially available switches and frequency band splitting devices will function well within the specified locations within the premise device 100.

Each of the switches 280, 290, 300, 310, 320, 330 is controlled either directly or indirectly by a microprocessor 810 (FIG. 3). The microprocessor 810 determines whether to actuate the switches 280, 290, 300, 310, 320, 330 to the first signal path set 910 or to the second signal path set 920 based on an information transmission signal preferably sent by the supplier 20. A signal coupler 360 allows for a receiver to 820 to receive the information transmission signal, such as a tone, a coded operational signal, or other well known information transmission, that can be understood by the microprocessor 810 to indicate the switch position. For example, the presence of an information signal can be used to indicate that the microprocessor 810 should select the second signal path set 920, whereas no information signal could indicate that microprocessor 810 should select the first signal path set 910. For example, the presence of a continuous tone at 900 MHz can be identified by passing a signal carrying such a tone through a band pass filter 830 to eliminate unnecessary signals and a comparator 840, which only provides a tone to the microprocessor when/if the tone is stronger than a predetermined threshold determined by a voltage source 850 and a resistive voltage divider 860. The frequency can be selected by the microprocessor 810 and can be tuned by a phase-locked loop control system 880 and an amplifier 870 in a manner well known in the art. Any of the high quality, commercially available microprocessors, signal couplers and receivers will function well within the specified locations with the premise device 100.

The premise device **100** preferably further includes circuit components creating the upstream bandwidth conditioning device **2**, which automatically increases the signal to noise ratio of the upstream bandwidth created on the user's premise and passed into the upstream bandwidths on the main signal distribution system **30**. It should be understood that with VOIP telephone service, the consistent flow of upstream data packets that lasts as long as the telephone call can appear to be noise (i.e., interference signals). Before VOIP, such continuous upstream flow data of data packets was not likely. Accordingly, the present device purposefully includes logic and structure that will halt the addition of attenuation once the maximum output of the cable modem is sensed even if the upstream data flow is consistent enough to be interpreted as noise.

As shown in FIGS. **3**, **4**, and **6a**, the upstream bandwidth conditioning device **2** of one embodiment of the premise device **100** includes a variable attenuator **400** and an amplifier **410**. The amount of signal level adjustment used to condition the upstream bandwidth is determined by the microprocessor **810** based on inputs from a signal level detector **390**. The signal level detector **390** measures and maintains a contemporary peak signal strength of the upstream bandwidth via a tap **370** and a filter **380**. The microprocessor **810** includes a counting circuit, a threshold comparison circuit and a level comparison circuit. It should be understood that even though a microprocessor **810** is used in the present embodiment, it is envisioned to control the variable attenuator **400** in the manner described using a traditional logic circuit.

As shown in FIG. **6b**, another embodiment of the upstream bandwidth conditioning device **2** includes a variable amplifier **415**, which is connected and controlled by the **810**. According to this embodiment, an attenuator **405** is present and is not controlled by the microprocessor. Other embodiments are envisioned that include both a variable amplifier **415** and a variable attenuator **405**. Further, the variable signal level adjustment device could also be an automatic gain control circuit ("AGC") and function well in the current device. In other words, it should also be understood that the amount of signal level adjustment and any incremental amount of additional signal level adjustment can be accomplished through any of a wide variety of amplification and/or attenuation devices.

In light of the forgoing, the term "variable signal level adjustment device" used herein should be understood to include not only a variable attenuation device, but also circuits containing a variable amplifier, AGC circuits, other variable amplifier/attenuation circuits, and related optical circuits that can be used to reduce the signal strength on the upstream bandwidth.

It should be noted that the term contemporary signal strength is intended to describe a current or present signal strength as opposed to a signal strength measured at a time in the past (i.e., a previous signal strength) such as prior to an application of signal level adjustment or an application of an additional amount of signal level adjustment. The reason for this point should be clear based on the following.

In operation, the microprocessor **810** within the upstream bandwidth conditioning device **2** performs a signal level setting routine **1000** (FIG. **7**) to determine an appropriate amount of signal level adjustment to apply to the upstream bandwidth via the variable attenuator **400**, the variable amplifier **415** or other suitable variable signal level adjustment device. The signal level setting routine can be run continuously, at predetermined intervals, and/or on command as a result of an information signal transmitted by the supplier **20**.

Once initiated, the microprocessor **810** or logic circuit performs the signal level setting routine in accordance with the flow chart shown in FIG. **7**.

Referring now to FIG. **7**, upon initialization **1010** of the signal level setting routine **1000**, the counting circuit in the microprocessor **810** is reset to zero (0), for example, in step **1020**. Next, the microprocessor **810** iteratively performs steps **1030**, **1040**, **1050**, **1060**, **1070**, **1080** and **1090** until the counter reaches a predetermined number (e.g. 25) or the answer to step **1080** is negative.

Specifically, in step **1030** the microprocessor **810** reads a contemporary signal strength from the signal level detector **390**, and the counter is incremented by a predetermined increment, such as one (1) in step **1040**. The microprocessor **810** then looks to see if the counter is greater than the predetermined number (i.e., 25). If so, the microprocessor **810** ends the routine, but if not, the microprocessor **810** proceeds to step **1060**. In step **1060**, the microprocessor **810** compares the contemporary signal strength to a predetermined threshold. If the contemporary signal strength is greater than the predetermined threshold, the microprocessor **810** instructs the variable attenuator **400** to add an amount of additional signal level adjustment (e.g. 1 dB), but if the contemporary signal strength is lower than the predetermined threshold, the microprocessor **810** returns to step **1030**.

After adding the amount of additional signal level adjustment, the microprocessor **810** reads a new contemporary signal strength in step **1080** while saving the previously read contemporary signal strength (i.e., from step **1030**) as a previous signal strength in preparation for step **1090**. In step **1090**, the microprocessor **810** compares the contemporary signal strength measured in step **1080** and the previous signal strength measured in step **1030** to one another. If the contemporary signal strength is equal to the previous signal strength then the microprocessor **810** returns to step **1030**, but if the contemporary signal strength is less than the previous signal strength the microprocessor **810** proceeds to step **1100** where it instructs the variable attenuator **400** to reduce the amount of signal level adjustment by a predetermined amount (e.g. the amount of additional signal level adjustment added in step **1070** or an amount greater than the additional signal level adjustment added in step **1070**). After step **1100**, the microprocessor **810** saves the total amount of signal level adjustment in step **1110** and stops the routine at step **1120**. Again, it should be understood that the amount of additional signal level adjustment may be added/removed by the variable amplifier **415**, or by the AGC discussed above.

As mentioned above, an important aspect of the present signal level setting routine is the comparison step conducted in step **1090**. A traditional cable modem **140** (FIG. **2**) used in CATV systems can adjust its output level based on information signals received from the supplier in the downstream bandwidth. In particular, if the modem signal received by the supplier **20** is weak, the supplier **20** instructs the modem **140** to increase its transmission signal level. As this relates to the current invention, the modem **140** will continually increase signal level as a result of increased amounts of upstream bandwidth signal level adjustment until the modem **140** can no longer increase its transmission signal strength. Accordingly, the contemporary signal strength measured in step **1080** after the addition of additional signal level adjustment in step **1070** should be equal to the previous signal strength if the modem **140** is able to compensate for the additional signal level adjustment. However, if the modem **140** is already producing its maximum signal strength, the contemporary signal

11

strength will be less than the previous signal strength when an additional amount of upstream bandwidth signal level adjustment is applied.

Because problems could result in the modem **140** from operating it at its maximum output (i.e., signal distortion may be high when the modem **140** is operating at or near a maximum level and/or the durability of the modem **140** may be sacrificed when the modem **140** is operating at or near a maximum level), the amount of signal level adjustment may be reduced by a sufficient amount in step **1100** to ensure quality of the output signal generated by the modem **140** and the durability of the modem **140** once the maximum output strength of the modem **140** is identified.

It is noted that in a system with more than one device passing data packets into the upstream bandwidth, the premise device **100** may identify the maximum output strength of one device and not the other. In other words, the premise device **100** may identify the first device achieving its maximum output strength without proceeding to identify the maximum output strength of any other devices. If the premise device **100** fails to identify the first observed maximum output strength, that device may continue to operate at its maximum output strength until another determination cycle is initiated.

The predetermined number compared in **1050** can be related directly to the amount of signal level adjustment. For example, if the variable signal level adjustment device is a step attenuator including 25 steps of 1 dB attenuation, as is the case in the embodiment represented in FIG. **6a**, the predetermined number can be set to 25 to allow for the finest resolution (i.e., 1 dB) and the broadest use of the particular step attenuator's range (i.e., 25 dB). It should be understood that the number of steps could be reduced and the resolution could be decreased (i.e., 5 steps of 5 dB) if faster overall operation is desired. It is also foreseeable that the predetermined number could be increased if a variable signal level adjustment device having a finer resolution (i.e., less than 1 dB) or a broader range (i.e., greater than 25 dB) is utilized. The incremented amount discussed here relating the counter and the predetermined number is one (1) such that there are 25 iterations (i.e., 25 steps) when the predetermined number is 25. The increment could easily be any number (i.e., 1, 5, 10, -1, -10, etc.) depending on the predetermined number and the total number of steps desired, which, as discussed above, is based on the desired resolution and the desired range of signal level adjustment.

The amount of additional attenuation added in step **1070**, and the predetermined amount of attenuation reduced in step **1100** are all variables that are currently based, at least partially, on hardware design limitations and can, depending on the hardware, be adjusted by one skilled in the art based on the conditions experienced in a particular CATV system and with particular CATV equipment. As discussed above, the variable signal level adjustment device in one embodiment of the present invention is a step attenuator having a resolution of 1 dB and a range of 25 dB. Accordingly, the amount of additional attenuation added in step **1070** using the present hardware could be 1 dB or multiples of 1 dB. Similarly, the predetermined amount of attenuation reduced in step **1100** can be 1 dB or multiples of 1 dB. It should be understood that if the amount of additional attenuation added in step **1070** is a multiple of 1 dB, such as 5 dB, the amount of attenuation reduced in step **1100** can be a lesser amount, such as 2 dB or 4 dB. The amount of attenuation reduced in step **1100** can also be greater than the amount of additional attenuation added in

12

step **1070** for the reasons stated above relating to maintaining the quality of the output from the modem **140** and the and durability of the modem **140**.

The predetermined threshold compared in step **1060** is a signal level sufficient to distinguish the presence of upstream data packets in the upstream bandwidth from interference signals. This value will vary depending on the output power of any cable modem **140**, STB, STU, etc. in the system and the average observed level of interference signals. A goal is, for example, to determine if a device is present that sends upstream data packets via the upstream bandwidth. If the predetermined threshold is set too low, the interference signals may appear to be upstream data packets, but if the predetermined threshold is set too high, the upstream data packets may appear as interference signals.

Any of the high quality, commercially available signal couplers, signal level detectors, variable attenuation devices, filters, amplifiers, and microprocessors will function well within the specified locations within the premise device **100**.

Referring now to FIGS. **3**, **4**, and **8**, the premise device **100** preferably includes circuit components creating the downstream bandwidth output level and/or output level tilt compensation device **3**, which helps to maintain a desired signal quality in transmitted signals using relatively high frequencies within the downstream bandwidth, which are much more susceptible to traditional parasitic losses. At a simplistic level, the microprocessor **810** observes channel data obtained from the tuner circuit **600**, compares the observed channel data to a known parasitic loss curve, and then adjusts a pair of variable output level compensation devices **440**, **450** and a variable slope adjusting circuit **460** located in the circuit **200** to create an output having a desired gain curve (i.e., a curve representative of transmitted signal strengths) across the downstream bandwidth. While each of the variable output level compensation devices **440**, **450** are depicted in FIGS. **4** and **8** as a variable attenuator, it should be understood that the term "variable output level compensation device" used herein should be understood to include not only a variable attenuation device, but also circuits containing a variable amplifier, AGC circuits, other variable amplifier/attenuation circuits, and related optical circuits that can be used to alter the signal strength of signals in the downstream bandwidth. Each of these steps will be discussed in further detail below.

The tuner circuit **600** obtains the downstream bandwidth from a coupler **420** drawing the downstream bandwidth off of the high frequency signal path **930** (FIG. **5**). Please note that these signals will be referred to herein as the coupled downstream bandwidth. The coupled downstream bandwidth is passed through a resistor **430** prior to being passed into a tuner **610**.

Through instructions provided by the microprocessor **810**, the tuner **610** scans the coupled downstream bandwidth in an effort to locate and identify a channel having a low frequency, referred to herein as a low band signal channel **1250** (FIG. **9**), and a channel having a high frequency, referred to herein as a high band signal channel **1260** (FIG. **9**). In the present instance, the microprocessor **810** instructs the tuner **610** to begin at the lowest frequency in the downstream bandwidth and scan toward higher frequencies until the low band signal channel **1250** is found. Similarly, the microprocessor **810** instructs the tuner **610** to begin at the highest frequency in the coupled downstream bandwidth and scan toward lower frequencies until the high band signal channel **1260** is found. Accordingly, the low band signal channel **1250** is a channel located near the lowest frequency within the coupled downstream bandwidth while the high band channel **1260** is a channel located near the highest frequency within the coupled

downstream bandwidth. Even though the low band signal channel **1250** and the high band signal channel **1260** are depicted in FIG. **9** as a single frequency for clarity, it should be understood that a channel is typically a range of frequencies. It should also be understood that the low band signal channel **1250** and the high band signal channel **1260** do not need to be the lowest or highest frequency channels, respectively. It is beneficial, however that the two channels be spaced as far apart from one another as practical to better estimate the amount of parasitic loss experiences across the entire downstream bandwidth.

During the scanning process to locate and identify the low and high band signal channels **1250**, **1260**, the tuner circuit **600** provides the microprocessor **810** with three types of information. First, a signal indicating that a channel has been identified is provided to the microprocessor **810** through input line **640**. Second, a signal indicating signal strength of the identified channel is provided to the microprocessor **810** through input line **630**. Third, a signal indicating the format of the identified channel is provided to the microprocessor **810** through input line **620**.

The signal indicating that a channel has been identified is created by passing the coupled downstream bandwidth through a band pass filter **650** to remove extraneous noise, a signal level detector **660** to convert signal into a voltage, and another signal level detector **670**. The signal leaving the signal level detector **670** is compared to a predetermined threshold voltage using comparator **680**. The predetermined threshold voltage is created using a voltage source **690** and an resistive divider **700**, and is set such that if the voltage associated with the coupled downstream bandwidth at the tuner frequency is greater than the threshold voltage, it is likely a channel in use by the supplier **20**, whereas if the voltage associated with the coupled downstream bandwidth at the tuner frequency is less than the threshold voltage, it is likely interference signals.

The signal indicating signal strength is created similarly to the signal indicating that a channel has been identified. The signal indicating signal strength passes through comparator **720** when it is greater than a threshold voltage created by a voltage source **730** and a resistive divider **740**. To clarify the differences, the signal indicating that a channel has been identified may not have any direct relation to the actual signal strength, whereas the signal indicating signal strength is directly proportional to the actual signal strength of the identified channel.

The signal indicating the format of the identified channel is created when the coupled downstream bandwidth passes through a channel analyzer, which includes the band pass filter **650**, the signal level detector **660**, a synch detector **750**, a low pass filter **760**, and a signal level detector **770**. The resulting signal identifies whether the identified channel is an analog format channel or another type of signal format.

According to current signal transmission specifications, digital format channels have a signal strength that is typically 6 dB less than a corresponding analog channel. Accordingly, the microprocessor **810** must include a level offset calculation that can account for this 6 dB difference when comparing the relative signal strengths of the low and high band signal channels **1250**, **1260**. If this inherent difference is not accounted for, any resulting comparisons of the two channels **1250**, **1260** for the purpose of determining relative signal strengths would necessarily be flawed. For example, if the high band channel **1260** is digital while the low band channel **1250** is analog, the additional, inherent 6 dB difference would incorrectly indicate that there is more parasitic losses than there actually is. Similarly, if the high band channel **1260** is

analog and the low band channel **1250** is digital, any resulting comparison would incorrectly indicate that there is less parasitic loss than there actually is. Therefore, it should be understood that it does not matter whether the 6 dB offset is added to the signal strength of a digital format channel or the 6 dB offset is subtracted from the signal strength of an analog format channel. Further, it should be understood that the 6 dB offset can be added to the signal strength of both the low and high band channels **1250**, **1260** if they are both digital or the 6 dB offset can be subtracted from the signal strength of both the low and high band channels **1250**, **1260** if they are both analog. Even further, it should be understood that the offset value is dictated by the standards observed by a particular supplier and can be, therefore, a value other than 6 dB.

After completing the scanning process and the process of adding/removing any offsets, the microprocessor **810** now has a low band signal strength (including any offset), a low band channel frequency, a high band signal strength (including any offset), and a high band channel frequency. The known information (i.e., the strength and frequency) of the low and high band channels **1250**, **1260** are now compared, by the microprocessor **810**, to a predetermined signal strength loss curve (i.e., a gain loss curve), which corresponds to the known parasitic losses associated with the type of coaxial/optical cables used, as shown in FIG. **9**. This step beneficially allows the known information to be interpolated across the entire downstream bandwidth. Using the interpolated curve, the microprocessor **810** determines how much signal level adjustment to apply and in what manner to apply the level adjustment across the entire downstream bandwidth such that the a resulting gain curve across the entire bandwidth is nearly linear and preferably with a slight increase in gain toward the higher frequencies in anticipation of parasitic losses that will occur downstream from the premise device **100**. For example, the amount of level is determined by the high band signal strength (i.e., high band gain) including any interpolation to the highest frequency, and the amount of level reduction is determined by the low band signal strength (i.e., low band level) including any interpolation to the lowest frequency.

It should be understood that parasitic losses affect higher frequencies more than lower frequencies. Accordingly, if a known signal having a -10 dB signal strength, for example, is transmitted at various frequencies across the entire downstream bandwidth and across a length of coaxial/optical cable, a plot of the resulting gain curve would result in a curve, which is known. Because the end goal is to have a gain curve that is a straight line near the original signal strengths or to have a gain curve that has an increasing slope versus frequency, the microprocessor **810** directly controls the variable slope adjustment circuit to adjust the downstream signal transmission in curve such that the lower frequencies are lower in amplitude than the higher frequencies.

For example, as shown in FIG. **9**, using the known frequency and signal strength for each of the low band channel **1250** and the high band channel **1260**, a gain curve **1210** can be plotted across the entire downstream bandwidth, which is shown, for example, as being from 50 MHz to 1000 MHz. The microprocessor **810** then determines a total amount of level adjustment to be added by the amplifier **490** and/or the amplifier **500** that will at least replace the loss at the highest frequency. In the present example, the amount of level adjustment would be at least $+38$ dB, resulting in a gain curve **1220** that is shown in FIG. **10**. Based on the interpolated gain curve shown in FIG. **9**, the microprocessor **810** instructs the variable slope circuit **460** to apply a similar, but inversely curved amount of correction to result in a relatively flat gain curve **1230** shown in FIG. **10**. It may be desirable to increase the

15

amount of level adjustment applied and increase the curvature of the slope adjustment to result in a gain curve 1240, as shown in FIG. 8, which has an increasing slope toward the higher frequencies.

As with the other devices discussed above, the downstream bandwidth output level and/or output level tilt compensation device 3 can be activated automatically upon initialization of the premise device 100, a set intervals, upon the occurrence of a particular event, and/or upon receipt of an information signal (e.g. a tone, a coded operating signal, etc.) from the supplier 20.

While the present invention has been particularly shown and described with reference to certain exemplary embodiments, it will be understood by one skilled in the art that various changes in detail may be effected therein without departing from the spirit and scope of the invention as defined by claims that can be supported by the written description and drawings. Further, where exemplary embodiments are described with reference to a certain number of elements it will be understood that the exemplary embodiments can be practiced utilizing either less than or more than the certain number of elements.

The following is claimed:

1. A frequency band selection device that can be inserted into a signal transmission line of a CATV system on the premise of a user, the device comprising:

at least two signal path sets between a tap-side and a premise-side, each of the at least two signal path sets comprising:

a first discrete signal path comprising a high frequency signal path allowing a downstream bandwidth to pass from the tap-side to the premise-side,

a second discrete signal path comprising a low frequency signal path allowing an upstream bandwidth to pass from the premise-side to the tap-side, and

the high frequency signal path and the low frequency signal path are separated by a cut-off transition frequency that is different for each of the at least two signal path sets; and

a switch controller having at least two discrete switch positions, the switch controller choosing one of the switch positions as a result of an information signal, each of the switch positions corresponding to a respective one of the at least two signal path sets.

2. The frequency band selection device of claim 1 further comprising:

a tap-side switch comprising an input terminal connected to a supplier side terminal; and

a tap-side filter set including a pair of frequency band splitting devices selectable by the tap-side switch,

wherein:

the tap-side switch comprises a first position directly connected to a first frequency band splitting device of the pair of frequency band splitting devices,

the first frequency band splitting device of the pair of frequency band splitting devices is associated with a first signal path set of the at least two signal path sets,

the tap-side switch comprises a second position directly connected to a second frequency band splitting device of the pair of frequency band splitting devices,

the second frequency band splitting device of the pair of frequency band splitting devices is associated with a second signal path set of the at least two signal path sets, and

the tap-side switch is actuated by the switch controller.

3. The frequency band selection device of claim 2, wherein at least one of the first frequency band splitting device of the

16

pair of frequency band splitting devices and the second frequency band splitting device of the pair of frequency band splitting devices separates the upstream bandwidth from the downstream bandwidth.

4. The frequency band selection device of claim 1 further comprising:

a premise-side switch connected to a premise-side terminal; and

a premise-side filter set including a pair of frequency band splitting devices selectable by the premise-side switch, wherein:

the premise-side switch comprises a first position directly connected to a first frequency band splitting device of the pair of frequency band splitting devices,

the first frequency band splitting device of the pair of frequency band splitting devices is associated with the first signal path set,

the premise-side switch comprises a second position directly connected to a second frequency band splitting device of the pair of frequency band splitting devices,

the second frequency band splitting device of the pair of frequency band splitting devices is associated with the second signal path set, and

the premise-side switch is actuated by the switch controller.

5. The frequency band selection device of claim 4, wherein one of the first frequency band splitting device of the pair of frequency band splitting devices and the second frequency band splitting device of the pair of frequency band splitting devices separates the upstream bandwidth from the downstream bandwidth.

6. The frequency band selection device of claim 1 further comprising:

a tap-side switch set connected between a first pair of frequency band splitting devices and a second pair of frequency band splitting devices; and

a premise-side switch set connected between the first pair of frequency band splitting devices and the second pair of frequency band splitting devices,

wherein the tap-side switch set and the premise-side switch set are actuated by the switch controller.

7. The frequency band selection device of claim 1, wherein the information signal comprises a continuous tone.

8. The frequency band selection device of claim 1, wherein the information signal comprises a coded operational signal.

9. The frequency band selection device of claim 1, wherein the at least two signal path sets comprises three signal path sets.

10. The frequency band selection device of claim 9, wherein the switch controller includes three discrete switch positions corresponding, respectively to the three signal path sets.

11. The frequency band selection device of claim 1, wherein each of the at least two signal path sets comprises at least one conductor providing an electrical transmission line between the tap-side and the premise-side.

12. A frequency band selection device comprising:

at least two signal path sets between a tap-side and a premise-side, each of the at least two signal path sets comprising:

a first discrete signal path comprising a high frequency signal path allowing a downstream bandwidth to pass from the tap-side to the premise-side,

a second discrete signal path comprising a low frequency signal path allowing an upstream bandwidth to pass from the premise-side to the tap-side, and

17

the high frequency signal path and the low frequency signal path are separated by a cut-off transition frequency that is different for each of the at least two signal path sets;

a switch controller having at least two discrete switch positions, the switch controller choosing one of the switch positions as a result of an information signal, each of the switch positions corresponding to a respective one of the at least two signal path sets;

a tap-side switch comprising an input terminal connected to a supplier side terminal;

a premise-side switch connected to a premise-side terminal;

a tap-side filter set including a first pair of frequency band splitting devices selectable by the tap-side switch; and

a premise-side filter set including a second pair of frequency band splitting devices selectable by the premise-side switch,

wherein:

each of the at least two signal path sets comprises at least one conductor providing an electrical transmission line between the tap-side and the premise-side,

the tap-side switch and the premise-side switch are actuated by the switch controller,

the tap-side switch comprises a first position directly connected to a first frequency band splitting device of the first pair of frequency band splitting devices,

18

the first frequency band splitting device of the first pair of frequency band splitting devices is associated with a first signal path set of the at least two signal path sets,

the tap-side switch comprises a second position directly connected to a second frequency band splitting device of the first pair of frequency band splitting devices,

the second frequency band splitting device of the first pair of frequency band splitting devices is associated with a second signal path set of the at least two signal path sets,

the premise-side switch comprises a first position directly connected to a first frequency band splitting device of the second pair of frequency band splitting devices,

the first frequency band splitting device of the second pair of frequency band splitting devices is associated with the first signal path set,

the premise-side switch comprises a second position directly connected to a second frequency band splitting device of the second pair of frequency band splitting devices, and

the second frequency band splitting device of the second pair of frequency band splitting devices is associated with the second signal path set.

* * * * *