



US009270990B2

(12) **United States Patent**
Lee et al.

(10) **Patent No.:** **US 9,270,990 B2**
(45) **Date of Patent:** ***Feb. 23, 2016**

(54) **METHOD FOR ENCODING AND DECODING IMAGES BASED ON CONSTRAINED OFFSET COMPENSATION AND LOOP FILTER, AND APPARATUS THEREFOR**

(52) **U.S. Cl.**
CPC *H04N 19/00369* (2013.01); *H04N 19/61* (2014.11); *H04N 19/70* (2014.11); *H04N 19/82* (2014.11)

(71) Applicant: **Electronics and Telecommunications Research Institute, Daejeon (KR)**

(58) **Field of Classification Search**
CPC . H04N 19/00369; H04N 19/61; H04N 19/70; H04N 19/82
USPC 375/240.02
See application file for complete search history.

(72) Inventors: **Jin Ho Lee**, Daejeon-si (KR); **Hui Yong Kim**, Daejeon-si (KR); **Sung Chang Lim**, Daejeon-si (KR); **Jin Soo Choi**, Daejeon-si (KR); **Jin Woong Kim**, Daejeon-si (KR)

(56) **References Cited**

(73) Assignee: **Electronics and Telecommunications Research Institute, Daejeon (KR)**

U.S. PATENT DOCUMENTS

2009/0003455 A1* 1/2009 Joung et al. 375/240.24
2012/0294353 A1* 11/2012 Fu et al. 375/240.02

(*) Notice: Subject to any disclaimer, the term of this patent is extended or adjusted under 35 U.S.C. 154(b) by 0 days.

This patent is subject to a terminal disclaimer.

(Continued)

FOREIGN PATENT DOCUMENTS

CN 1451232 A 10/2003
CN 101459847 A 6/2009

(Continued)

(21) Appl. No.: **14/347,709**

OTHER PUBLICATIONS

(22) PCT Filed: **Sep. 27, 2012**

“WD4: Working Draft 4 of High-Efficiency Video Coding” Joint Collaborative Team on Video Coding (JCT-VC) of ITU-T SGI6 WP3 and ISO/IEC JTC1/SC29/WG11 6th Meeting: Torino, IT, Jul. 14-22, 2011, Document JCTVC-F803 to Bross et al.*

(86) PCT No.: **PCT/KR2012/007833**

§ 371 (c)(1),
(2) Date: **Mar. 27, 2014**

(Continued)

(87) PCT Pub. No.: **WO2013/048151**

Primary Examiner — Mohammed Rahaman

PCT Pub. Date: **Apr. 4, 2013**

(74) *Attorney, Agent, or Firm* — NSIP Law

(65) **Prior Publication Data**

US 2014/0286396 A1 Sep. 25, 2014

(57) **ABSTRACT**

(30) **Foreign Application Priority Data**

Sep. 28, 2011 (KR) 10-2011-0098601
Feb. 28, 2012 (KR) 10-2012-0019999
Apr. 16, 2012 (KR) 10-2012-0039412
Sep. 27, 2012 (KR) 10-2012-0107639

Provided are a method and apparatus for encoding and decoding images based on constrained offset compensation and a loop filter. The image decoding apparatus: receives, from an encoder, a first indicator indicating whether a sequence, a picture, a frame, a slice, a coding unit (CU), a prediction unit (PU), and/or a transform unit (TU) supports constrained offset compensation; receives, from the encoder, a second indicator indicating whether constrained sample adaptive offset (SAO) compensation or an adaptive loop filter (ALF) is applied; receives a parameter from the encoder; and applies the SAO compensation or the ALF to pixels of a restored image on the basis of the second indicator and the parameter.

(51) **Int. Cl.**
H04N 19/44 (2014.01)
H04N 19/196 (2014.01)

(Continued)

10 Claims, 12 Drawing Sheets

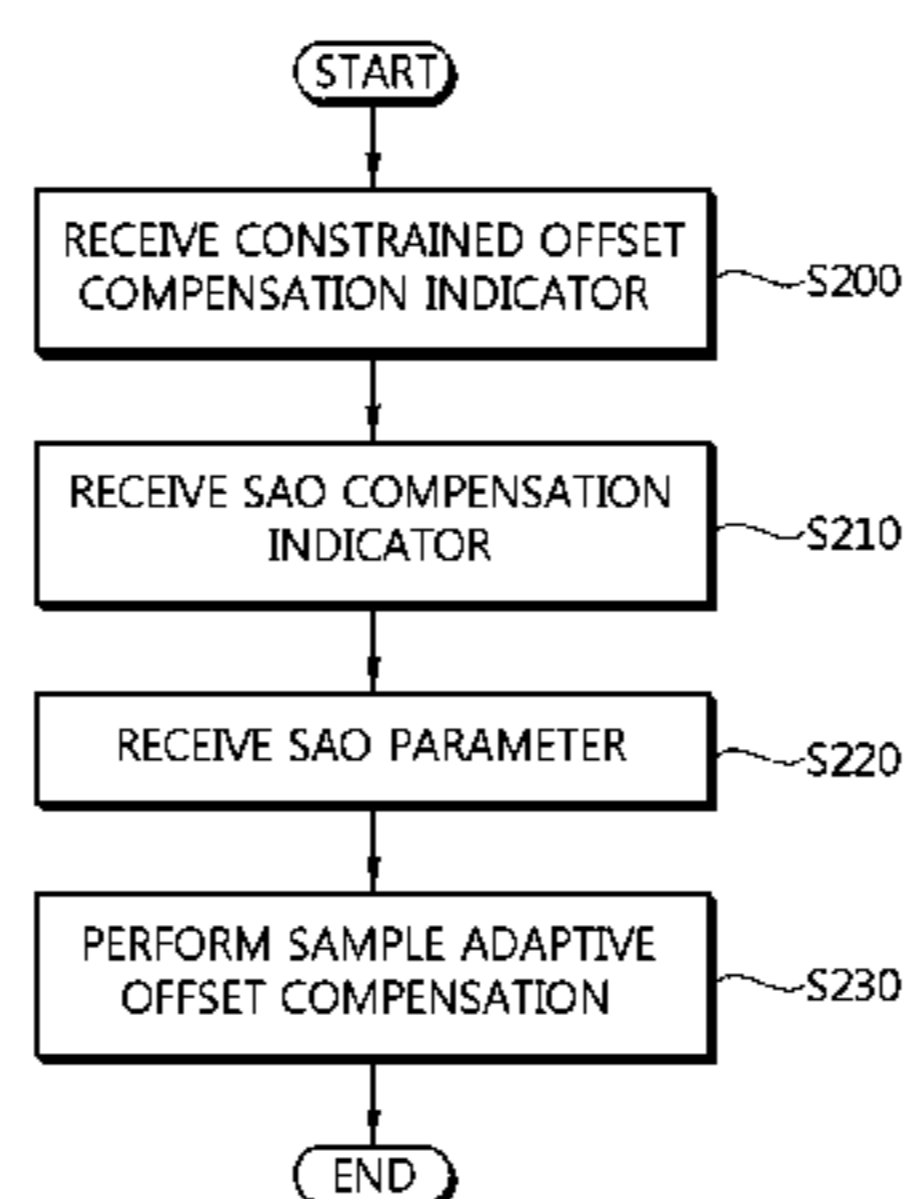

- (51) **Int. Cl.**
H04N 19/82 (2014.01)
H04N 19/70 (2014.01)
H04N 19/61 (2014.01)

(56) **References Cited**

U.S. PATENT DOCUMENTS

2013/0003829	A1 *	1/2013	Misra et al.	375/240.12
2013/0051454	A1 *	2/2013	Sze et al.	375/240.02
2013/0101035	A1 *	4/2013	Wang et al.	375/240.12

FOREIGN PATENT DOCUMENTS

CN	101491102	A	7/2009
CN	101778286	A	7/2010
EP	1 574 995	A1	9/2005
KR	10-2005-0099256	A	10/2005
KR	10-0896291	B1	5/2009
KR	10-2010-0135638	A	12/2010
KR	10-2011-0068897	A	6/2011
WO	WO 2008/033595	A2	3/2008

OTHER PUBLICATIONS

International Search Report issued Feb. 18, 2013 in corresponding International Patent Application No. PCT/KR20912/007833 (4 pages, in Korean).

Korean Office Action issued Oct. 18, 2013 in corresponding Korean Patent Application No. 10-2012-0107639 (4 pages, in Korean).

Bordes, P., Clare, G., Henry, F., Raulet, M., & Viéron, J. "An overview of the emerging HEVC standard" in *IEEE 2010* (4 pages).

Fu, Chih-Ming, et al. "CE13: Sample Adaptive Offset with LCU-Independent Decoding", Joint Collaborative Team on Video Coding (JCT-VC) of ITU-T SG16 WP3 and ISO/IEC JTC1/SC29/WG11 5th Meeting: Geneva, CH, [JCTVC-E049], Mar. 16-23, 2011 (7 pages, in English).

Fu, Chih-Ming, et al. "Sample Adaptive Offset for Chroma", Joint Collaborative Team on Video Coding (JCT-VC) of ITU-T SG16 WP3 and ISO/IEC JTC1/SC29/WG11 6th Meeting: Torino, IT, [JCTVC-F057], Jul. 14-22, 2011 (5 pages, in English).

Bross, Benjamin, et al. "WD4: Working Draft 4 of High-Efficiency Video Coding", Joint Collaborative Team on Video Coding (JCT-VC) of ITU-T SG16 WP3 and ISO/IEC JTC1/SC29/WG11 6th Meeting: Torino, IT, [JCTVC-F803_d1] (version 3), Sep. 8, 2011 (6 pages, in English).

Japanese Office Action mailed Sep. 30, 2014 in counterpart Japanese Application No. 2014-083073 (4 pages, in Japanese).

Chinese Office Action issued by SIPO on Dec. 25, 2014 for the corresponding CN Application. 201280058538.7 (19 pages with complete English Translation).

Bross, Benjamin, et al. "WD5: Working Draft 5 of High-Efficiency Video Coding." Joint Collaborative Team on Video Coding (JCT-VC) of ITU-T SG16 WP3 and ISO/IEC JTC1/SC29/WG11 7th Meeting: Geneva, Switzerland [JCTVC-G1103_d8], Nov. 2011 (5 pages, in English).

Sullivan, G. et al., "Meeting report of the sixth meeting of the Joint Collaborative Team on Video Coding (JCT-VC), Torino, IT, Jul. 14-22, 2011", Joint Collaborative Team on Video Coding (JCT-VC) of ITU-T SG16 WP3 and ISO/IEC JTC1/SC29/WG11 6th Meeting: Torino, IT, Jul. 14-22, 2011 (4 pages in English).

Chih-Ming Fu, et al., "Sample Adaptive Offset with Padding at LCU, Slice, and Image Boundaries" Joint Collaborative Team on Video Coding (JCT-VC) of ITU-T SG16 WP3 and ISO/IEC JTC1/SC29/WG11, 6th Meeting: Torino, IT, Jul. 14-22, 2011, Document: JCTVC-F093 (7 pages In English).

Jinho Lee, et al., "Deblocking filter modification for constrained intra prediction" Joint Collaborative Team on Video Coding (JCT-VC) of ITU-T SG16 WP3 and ISO/IEC JTC1/SC29/WG11, 6th Meeting: Torino, IT, Jul. 14-22, 2011, Document: JCTVC-F359 (8 pages in English).

Minhua Zhou, et al., "BoG report on review of deblocking filter related contributions" Joint Collaborative Team on Video Coding (JCT-VC) of ITU-T SG16 WP3 and ISO/IEC JTC1/SC29/WG11, 6th Meeting: Torino, IT, Jul. 14-22, 2011, Document: JCTVC-F763 (10 pages in English).

Osnat Bar-Nir, et al., "Proposal to Improve Ultra Low Delay Coding with Minimal Decoder Impact" Joint Collaborative Team on Video Coding (JCT-VC) of ITU-T SG16 WP3 and ISO/IEC JTC1/SC29/WG11, 8th Meeting: San Jose, CA, USA, Feb. 1-10, 2012, Document: JCTVC-H0471 (3 pages in English).

Ye-Kui Wang, et al., "Flexible tile dependency and loop filtering control" Joint Collaborative Team on Video Coding (JCT-VC) of ITU-T SG16 WP3 and ISO/IEC JTC1/SC29/WG11, 8th Meeting: San Jose, CA, USA, Feb. 1-10, 2012, Document: JCTVC-G0520 (7 pages in English).

Ranga Ramanujam Srinivasan, et al., "AHG15: Slice-Level Control of In-Loop Filter" Joint Collaborative Team on Video Coding (JCT-VC) of ITU-T SG16 WP3 and ISO/IEC JTC1/SC29/WG11, 8th Meeting: San Jose, CA, USA, Feb. 1-10, 2012, Document: JCTVC-G0391 (6 pages in English).

Jinho Lee, et al., "AHG10: Constrained in-loop filtering" Joint Collaborative Team on Video Coding (JCT-VC) of ITU-T SG16 WP3 and ISO/IEC JTC1/SC29/WG11, 9th Meeting: Geneva, CH, Apr. 27-May 7, 2012, Document: JCTVC-I0105 (5 pages in English).

Extended European Search Report issued on Sep. 7, 2015 in counterpart European Application No. 12835079.0 (10 pages in English).

Extended European Search Report issued on Sep. 7, 2015 in counterpart European Application No. 14181502.7 (10 pages in English).

* cited by examiner

FIG. 1

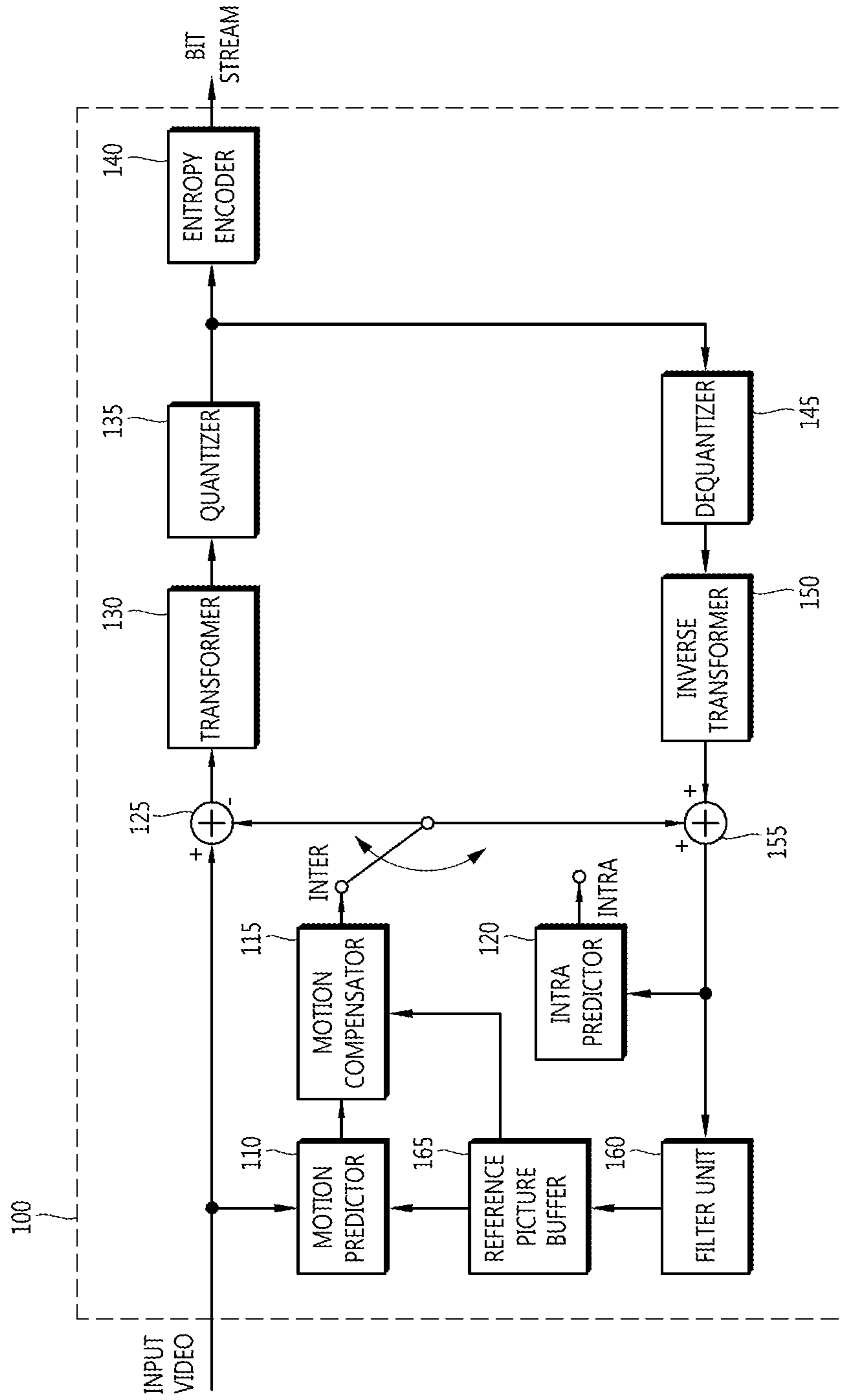

FIG. 2

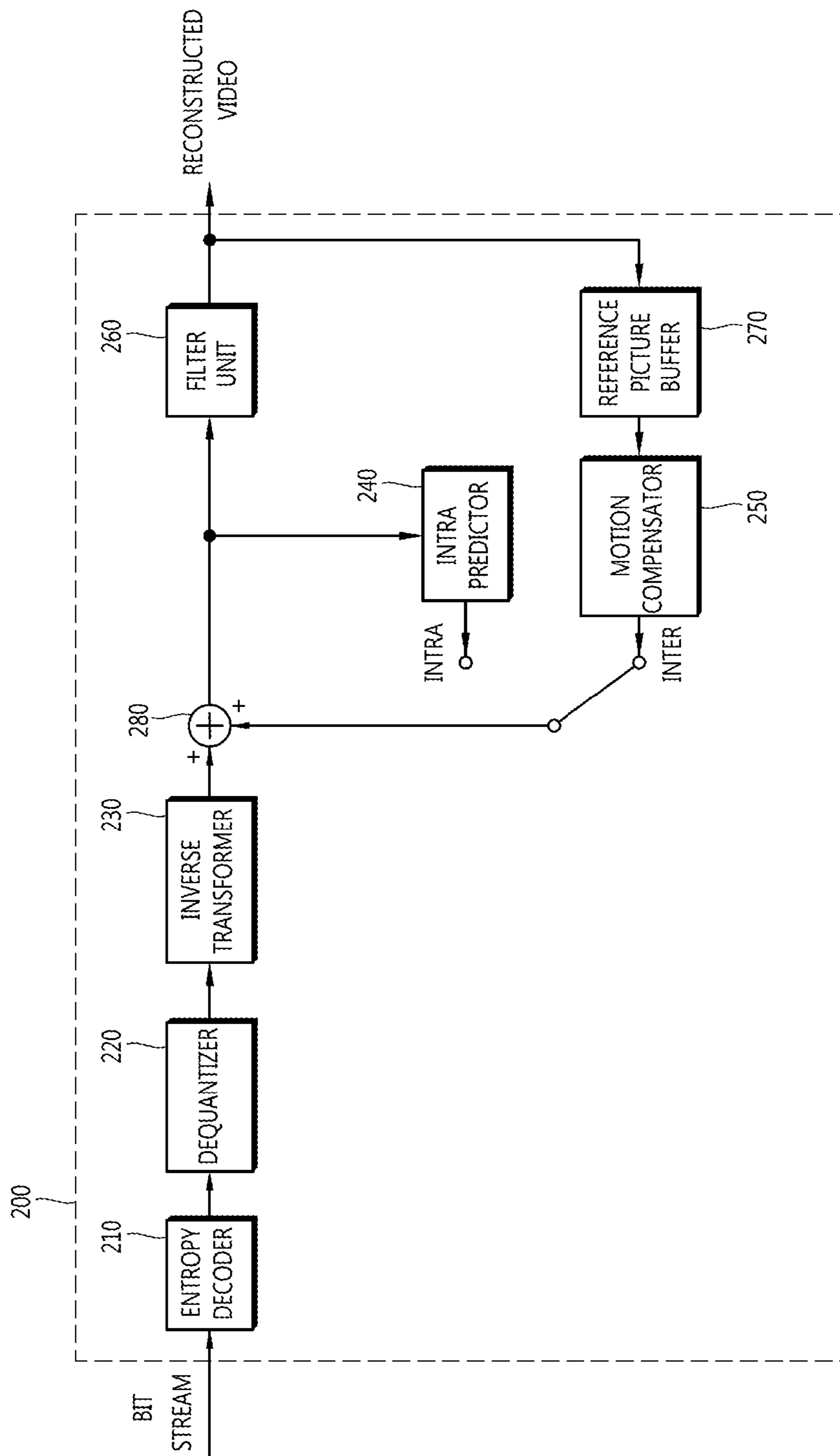

FIG. 3

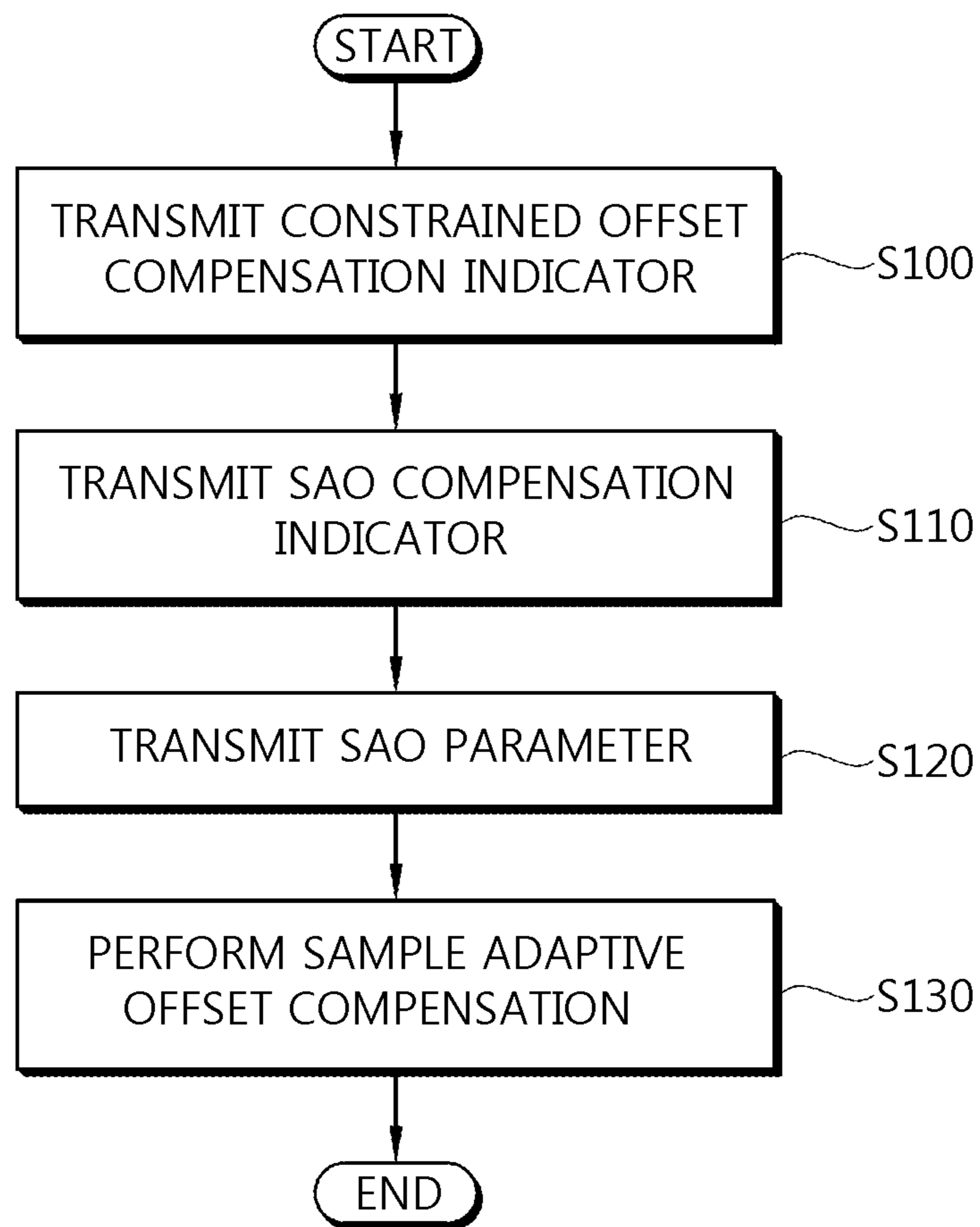

FIG. 4

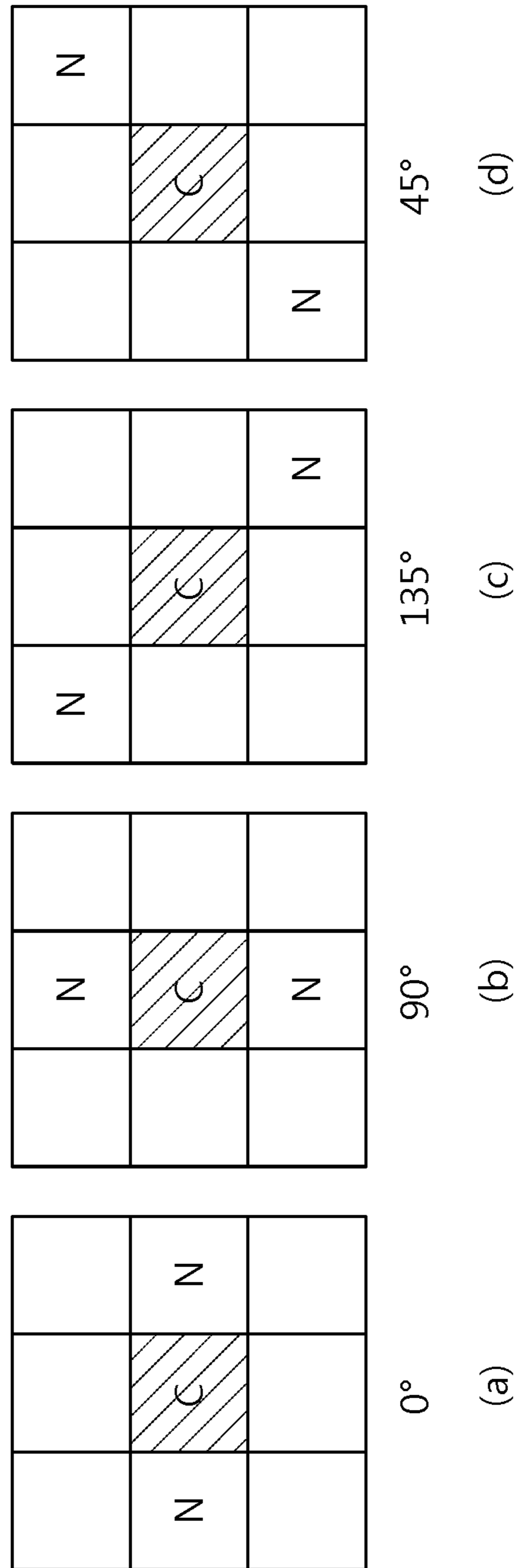

FIG. 5

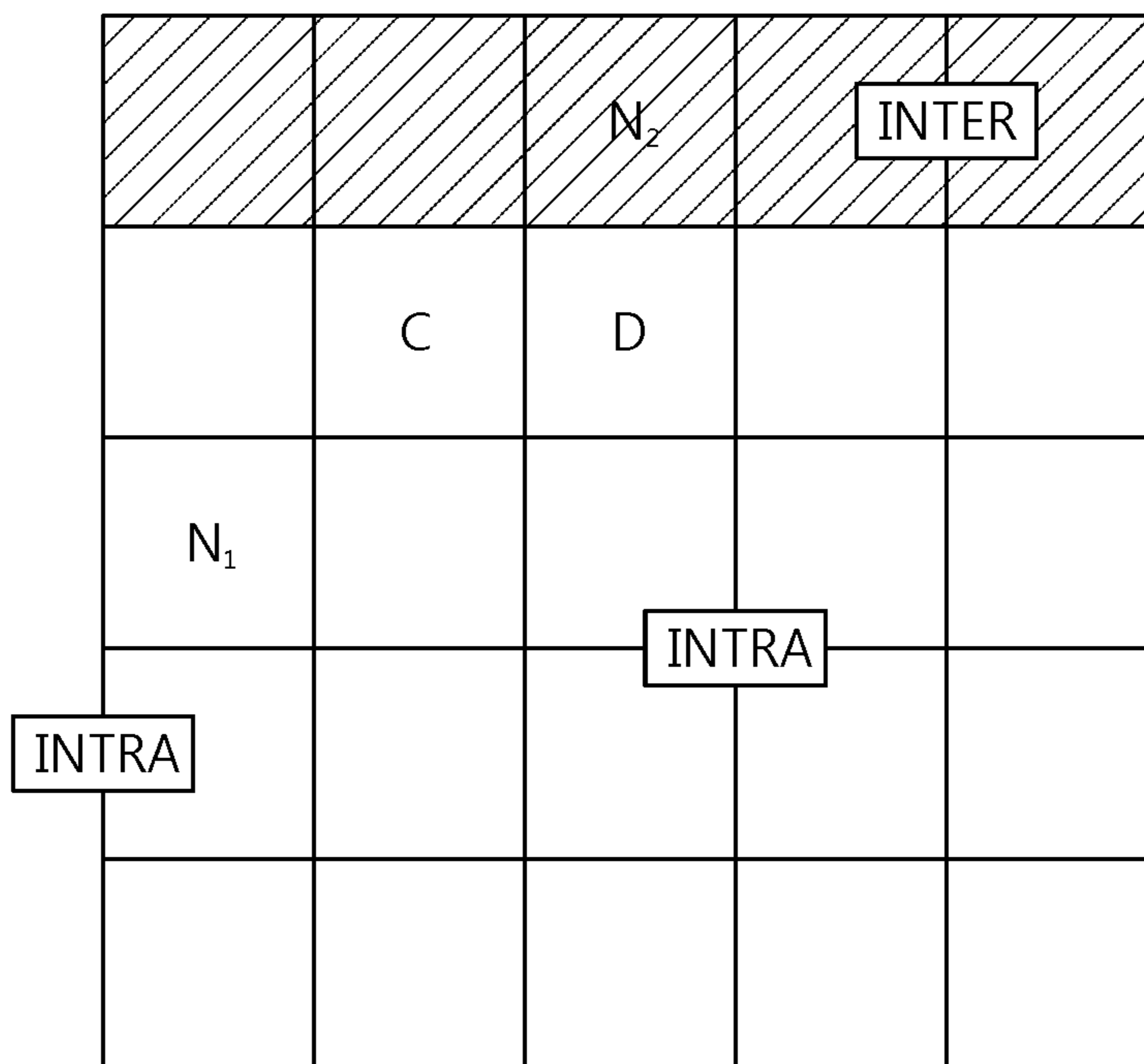

FIG. 6

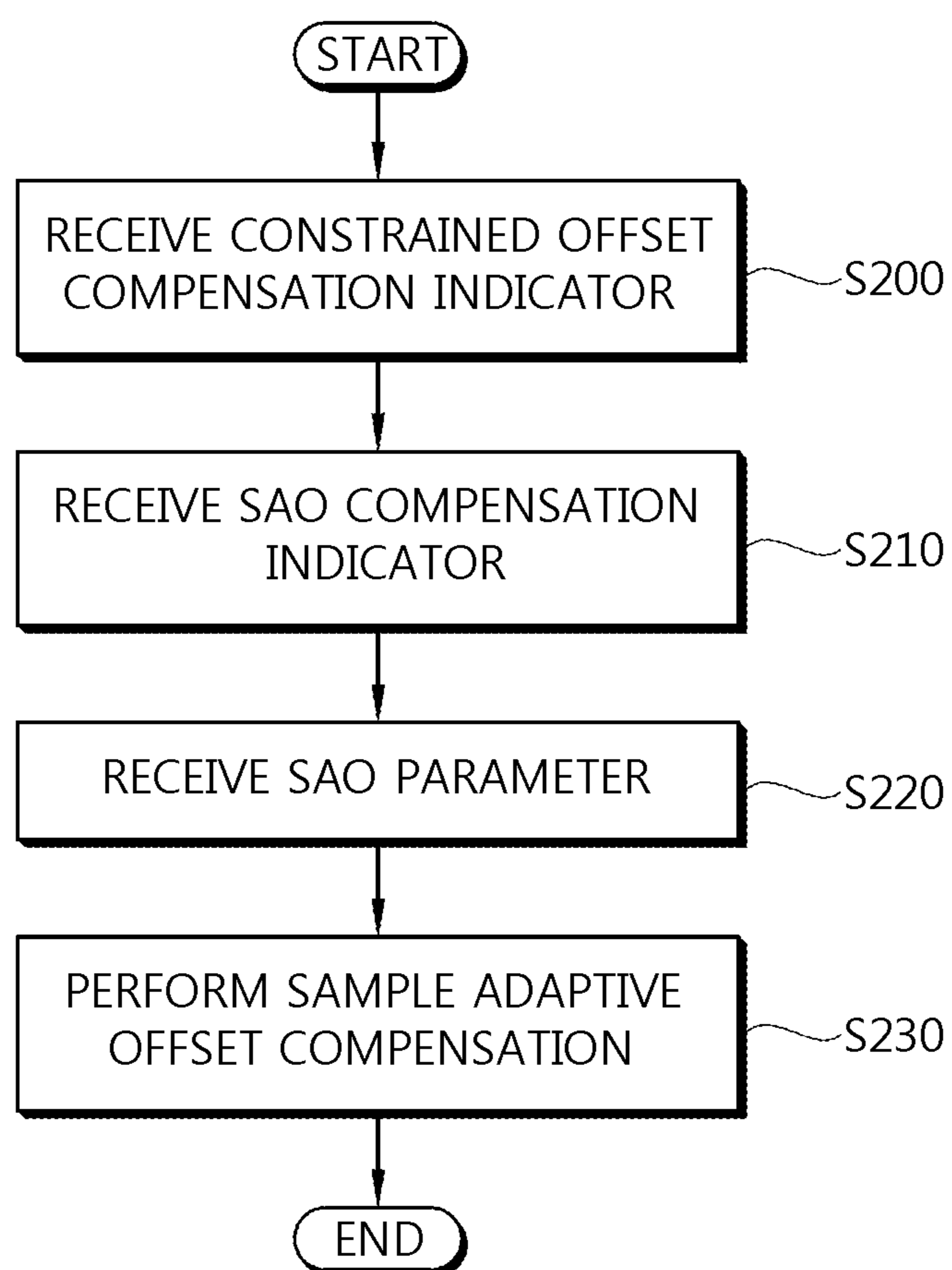

FIG. 7

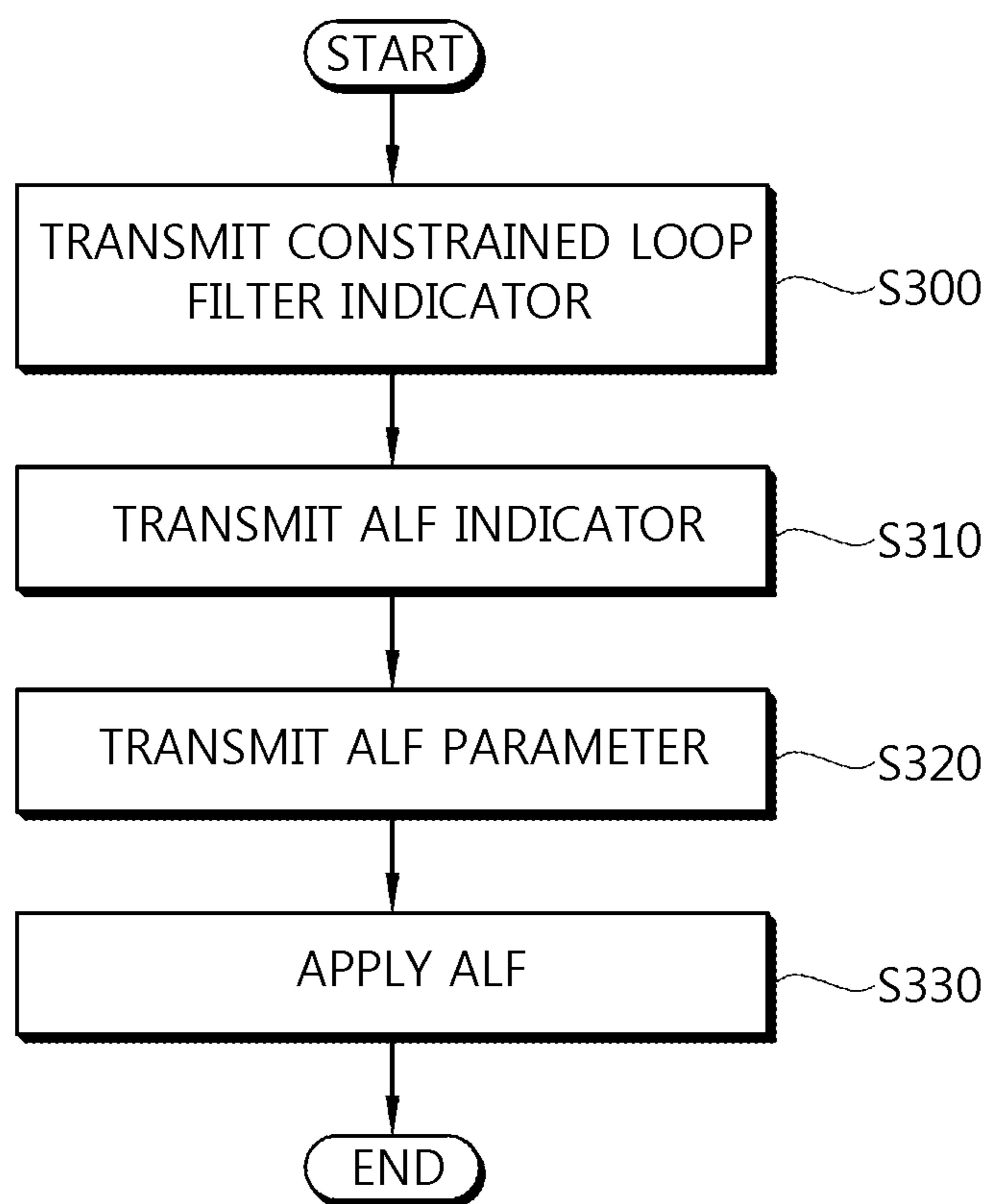

FIG. 8

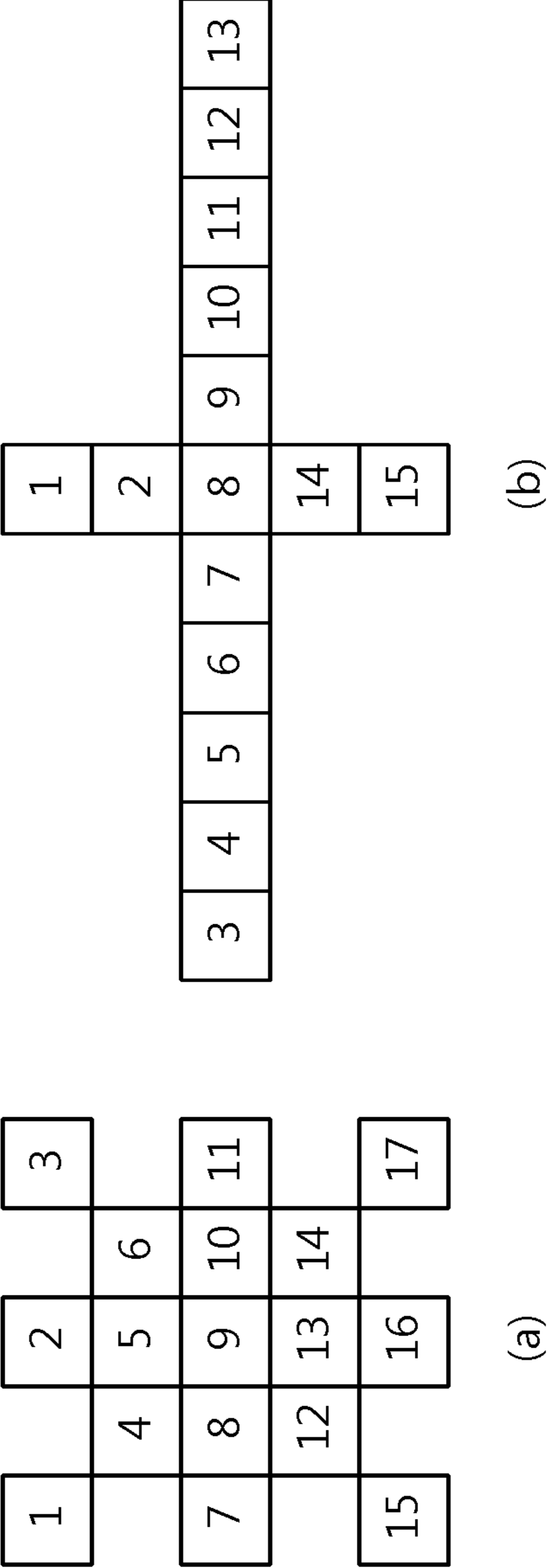

FIG. 9

$R_{(-1,-1)}$	$R_{(-1,0)}$	$R_{(-1,1)}$	$R_{(-1,2)}$	$R_{(-1,3)}$
$R_{(0,-1)}$	$R_{(0,0)}$	$R_{(0,1)}$	$R_{(0,2)}$	$R_{(0,3)}$
$R_{(1,-1)}$	$R_{(1,0)}$	$R_{(1,1)}$	$R_{(1,2)}$	$R_{(1,3)}$
$R_{(2,-1)}$	$R_{(2,0)}$	$R_{(2,1)}$	$R_{(2,2)}$	$R_{(2,2)}$
$R_{(3,-1)}$	$R_{(3,0)}$	$R_{(3,1)}$	$R_{(3,2)}$	$R_{(3,3)}$

$$VA = | 2R_{(i,j)} - R_{(i-1,j)} - R_{(i+1,j)} |$$

$$HA = | 2R_{(i,j)} - R_{(i,j-1)} - R_{(i,j+1)} |$$

$i=0,2$
 $j=0,2$

FIG. 10

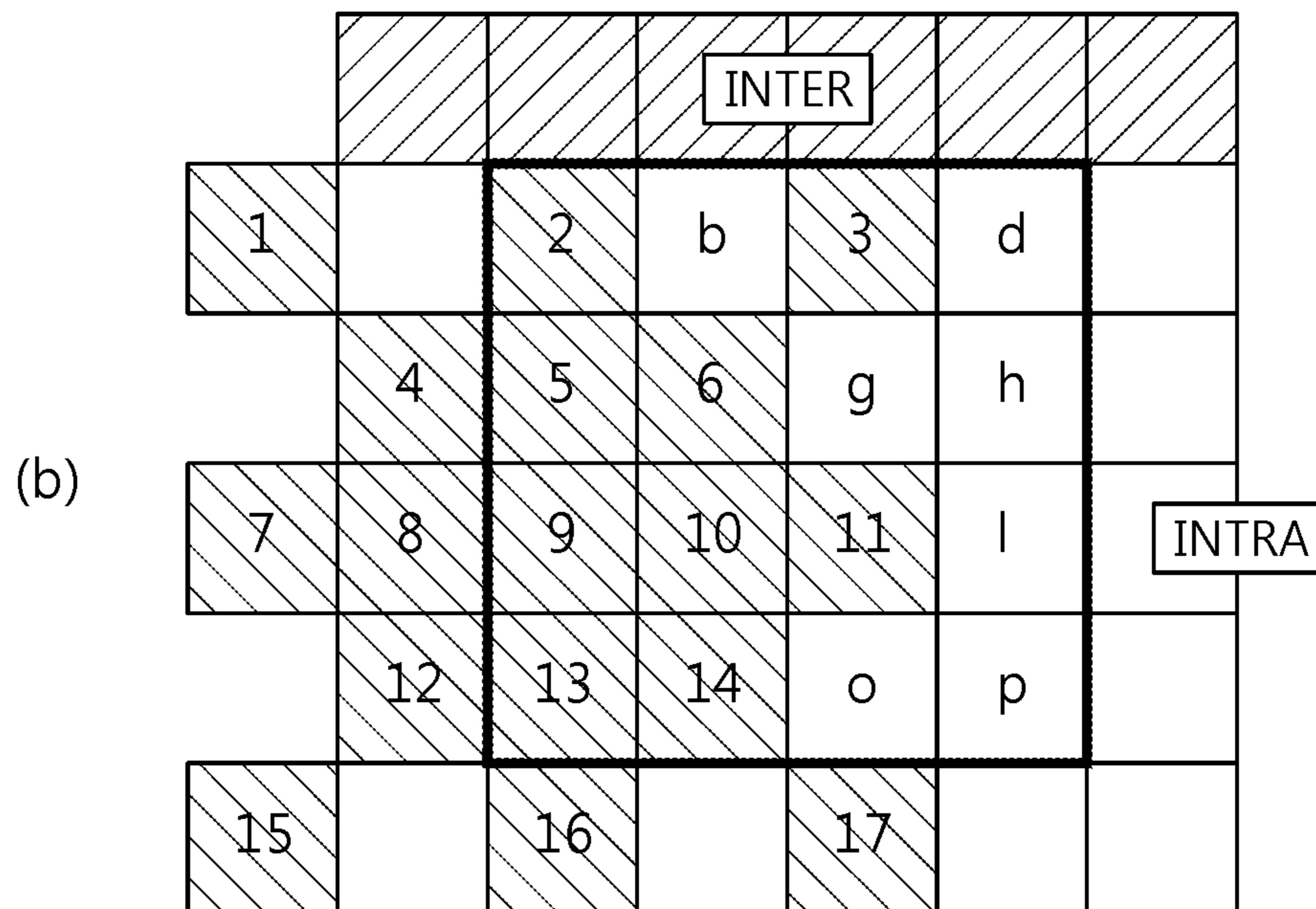
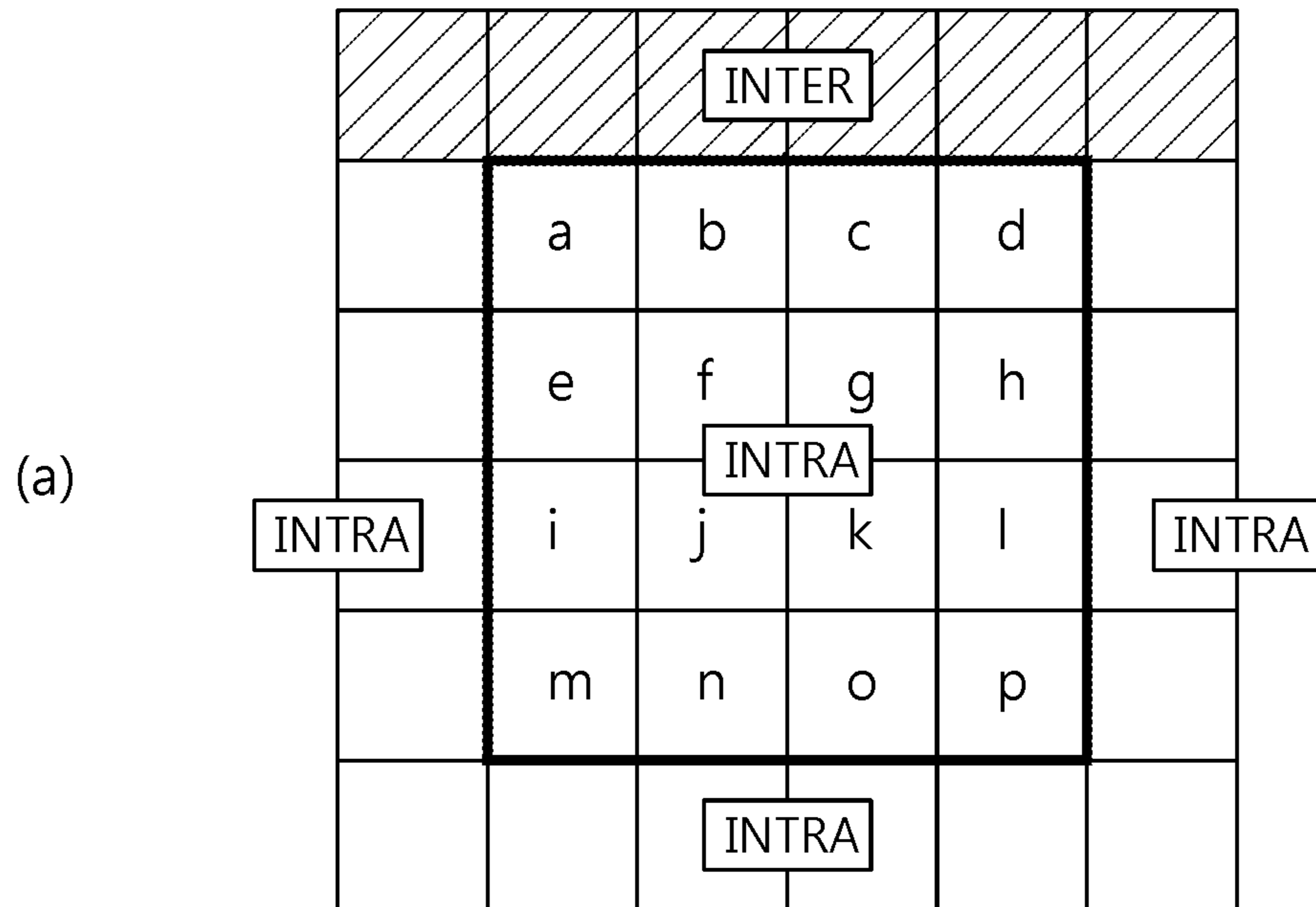

FIG. 11

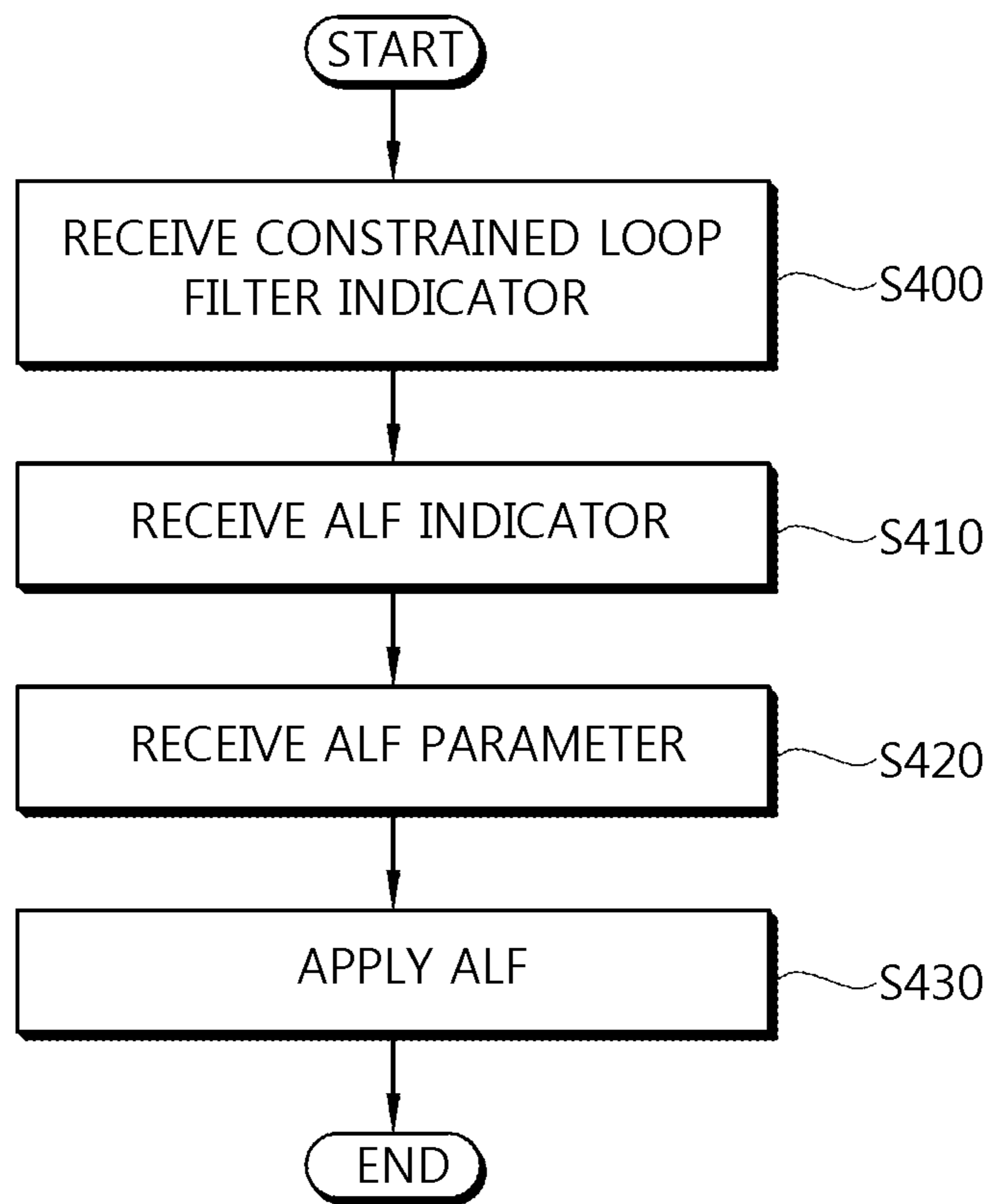
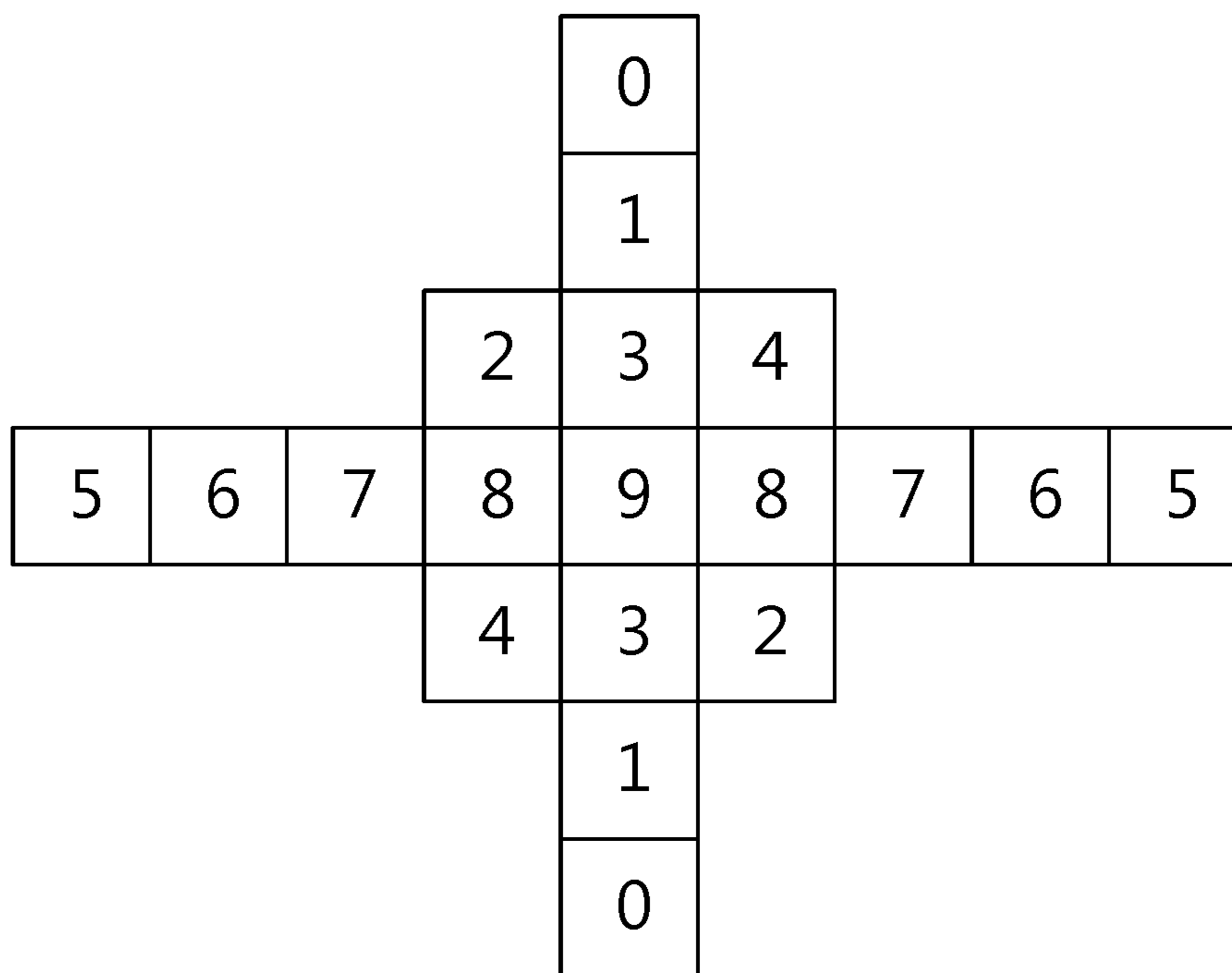

FIG. 12



1

**METHOD FOR ENCODING AND DECODING
IMAGES BASED ON CONSTRAINED OFFSET
COMPENSATION AND LOOP FILTER, AND
APPARATUS THEREFOR**

CROSS-REFERENCE TO RELATED
APPLICATIONS

This application is a National Stage of International Application No. PCT/KR2012/007833, filed Sep. 27, 2012 and published as WO 2013/048151 on Apr. 4, 2013, which claims the benefit of Korean Patent Application Nos. 10-2012-0107639 filed on Sep. 27, 2012, 10-2012-0039412 filed on Apr. 16, 2012, 10-2012-0019999 filed on Feb. 28, 2012 and 10-2011-0098601 filed on Sep. 28, 2011 the entire disclosures of which are incorporated herein by reference for all purposes.

TECHNICAL FIELD

The present invention relates to digital video, and more particularly, to a method and an apparatus for encoding and decoding video based on constrained offset compensation and filtering.

BACKGROUND ART

Recently, with the expansion of broadcasting services supporting high definition (HD) resolution in the country and around the world, many users have been accustomed to a high resolution and definition video, such that many organizations have conducted many attempts to develop next-generation video devices. In addition, the interest in HDTV and ultra high definition (UHD) having a resolution four times higher than that of HDTV have increased and thus, a compression technology for higher-resolution and higher-definition video have been required.

Examples of the video compression technology may include an inter prediction technology predicting sample values included in a current picture from a picture before and/or after the current picture, an intra prediction technology predicting sample values included in the current picture using sample information in the current picture, a weight prediction technology for preventing deterioration of image quality due to a change in illumination, and the like, an entropy encoding technology allocating a short code to symbols having a high appearance frequency and a long code to symbols having a low appearance frequency, and the like. In particular, when the prediction for the current block is performed in a skip mode, the predicted block is generated by using only predicted values from a previously encoded region and separate motion information or a residual signal is not transmitted from an encoder to a decoder. Video data may be effectively compressed by the video compression technologies.

In order to minimize a difference between an original video and a reconstructed video at the time of encoding and decoding video, offset compensation or a loop filter may be applied. In the case of the offset compensation, and distortion from the original video can be minimized by calculating errors of sample values between the original video and the reconstructed video to obtain offsets and by applying the obtained offsets to the reconstructed video. In the case of the loop filter, the distortion from the original video can be minimized by deriving filter coefficients based on a Wiener filter minimizing errors between the original video and the reconstructed video and then, applying the derived filter coefficients to the reconstructed video.

2

Meanwhile, the compressed video bit streams may be transmitted through a network channel in which errors easily occur. However, when errors occur in the compressed video bit streams, the offset compensation or the loop filter according to the related art do not have the countermeasures therefore and therefore, the errors may be temporally or spatially propagated by the offset compensation or the loop filter. Therefore, the offset compensation or the loop filter according to the related art may largely degrade the image quality of the reconstructed video and the compressed video bit streams cannot be decoded.

Therefore, there is a need to apply the error-resilient offset compensation or loop filter.

SUMMARY OF INVENTION

Technical Problem

The present invention provides a method and an apparatus for encoding and decoding video based on constrained offset compensation and filtering. In addition, the present invention provides a method for constraining an application of offset compensation or a loop filter at the time of encoding and decoding video by using encoding parameters of at least one of a target block of a sample adaptive offset compensation or loop filter and neighboring blocks of the target block.

Technical Solution

In an aspect, a method for decoding a video is provided. The method includes receiving a constrained offset compensation indicator indicating whether at least one of a sequence, a picture, a frame, a slice, a coding unit (CU), a prediction unit (PU), and a transform unit (TU) supports constrained offset compensation from an encoder, receiving a sample adaptive offset (SAO) compensation indicator indicating whether sample adaptive offset compensation is performed or not from the encoder, receiving an SAO parameter from the encoder, and performing the sample adaptive offset compensation on a sample of a reconstructed video based on the SAO compensation indicator and the SAO parameter.

In another aspect, a method for encoding a video is provided. The method includes transmitting a constrained offset compensation indicator indicating whether at least one of a sequence, a picture, a frame, a slice, a coding unit (CU), a prediction unit (PU), and a transform unit (TU) supports constrained offset compensation to a decoder, transmitting a sample adaptive offset (SAO) compensation indicator indicating whether SAO compensation is performed or not to the decoder, transmitting an SAO parameter to the decoder, and performing the sample adaptive offset compensation on a sample of a reconstructed video based on the SAO compensation indicator and the SAO parameter.

In another aspect, a method for encoding a video is provided. The method includes transmitting a constrained loop filter indicator indicating whether at least one of a sequence, a picture, a frame, a slice, a coding unit (CU), a prediction unit (PU), and a transform unit (TU) supports application of a constrained loop filter to a decoder, transmitting an adaptive loop filter (ALF) application indicator indicating whether the ALF is applied or not to the decoder, transmitting the ALF parameter to the decoder, and applying the ALF to a sample of a reconstructed video based on the ALF application indicator and the ALF parameter.

The exemplary embodiments of the present invention can apply the offset compensation or loop filter so as to withstand errors at the time of encoding and decoding video.

DESCRIPTION OF DRAWINGS

FIG. 1 is a block diagram of a video encoding apparatus according to an embodiment of the present invention.

FIG. 2 is a block diagram of a video decoding apparatus according to an embodiment of the present invention.

FIG. 3 shows an example of a proposed video encoding method according to an embodiment of the present invention.

FIG. 4 shows a type of an edge offset determined according to an angle.

FIG. 5 shows an example of a diagram showing a case in which the offset categories and the offset signs are determined in a type of an edge offset by using encoding parameters according to an embodiment of the present invention.

FIG. 6 shows an example of a proposed video decoding method according to an embodiment of the present invention.

FIG. 7 shows another example of a proposed video encoding method according to an embodiment of the present invention.

FIG. 8 shows an example of a filter shape determined by an encoder in the proposed video encoding method according to an embodiment of the present invention.

FIG. 9 shows a case in which a filter is classified based on a BA method by using encoding parameters in the proposed video encoding method according to an embodiment of the present invention.

FIG. 10 shows an example of a case in which an ALF is applied using the encoding parameters in the proposed video encoding method according to an embodiment of the present invention.

FIG. 11 shows another example of a proposed video decoding method according to an embodiment of the present invention.

FIG. 12 shows an example of a filter shape used in the proposed video decoding method according to an embodiment of the present invention.

MODE FOR INVENTION

Hereinafter, exemplary embodiments of the present invention will be described in detail with reference to the accompanying drawings. Further, in describing exemplary embodiments of the present invention, well-known functions or constructions will not be described in detail since they may unnecessarily obscure the understanding of the present invention.

It is to be understood that when any element is referred to as being “connected to” or “coupled to” another element, it may be connected directly to or coupled directly to another element or be connected to or coupled to another element, having the other element intervening therebetween. Further, in the present specification, in the case of describing “including” a specific component, it is to be understood that additional components other than a corresponding component are not excluded, but may be included in exemplary embodiments or the technical scope of the present invention.

Terms used in the specification, ‘first’, ‘second’, etc., may be used to describe various components, but the components are not to be construed as being limited to the terms. That is, the terms are used to distinguish one component from another component. Therefore, the first component may be referred to

as the second component, and the second component may be referred to as the first component.

In addition, components described in exemplary embodiments of the present invention are independently shown only in order to indicate that they perform different characteristic functions. Therefore, the components that are independently shown do not mean that each of the components may not be implemented as one hardware or software. That is, each of the components is divided for convenience of explanation, a plurality of components may be combined with each other to thereby be operated as one component or one component may be divided into a plurality of components to thereby be operated as the plurality of components, which are included in the scope of the present invention as long as it departs from essential characteristics of the present invention.

In addition, some of components may not be indispensable components performing essential functions of the present invention, but be selective components improving only performance thereof. The present invention may also be implemented only by a structure including the indispensable components except for the selective components, and the structure including only the indispensable components is also included in the scope of the present invention.

FIG. 1 is a block diagram of a video encoding apparatus according to an embodiment of the present invention.

Referring to FIG. 1, a video encoding apparatus 100 includes a motion predictor 110, a motion compensator 115, an intra predictor 120, a subtractor 125, a transformer 130, a quantizer 135, an entropy encoder 140, a dequantizer 145, an inverse transformer 150, an adder 155, a filter unit 160, and a reference picture buffer 165.

The video encoding apparatus 100 may encode the input video with an intra mode or an inter mode and output bit stream. In the case of the intra mode, the prediction may be performed in the intra predictor 120 and in the case of the inter mode, the prediction may be performed in the motion predictor 110, the motion compensator 115, and the like. The video encoding apparatus 100 may generate a predicted block for an input block of the input video and then, encode a difference between the input block and the predicted block.

In the intra mode, the intra predictor 120 uses sample values of the already encoded block around a current block to perform spatial prediction, thereby generating the predicted block.

In the case of the inter mode, the motion predictor 110 may obtain a motion vector by finding out a region which is best matched with the input block in a reference picture stored in the reference picture buffer 165 during a motion prediction process. The motion compensator 115 uses the motion vector and the reference picture that is stored in the reference picture buffer 165 to perform the motion compensation, thereby generating the predicted block.

The subtractor 125 may generate a residual block due to a difference between the input block and the generated predicted block. The transformer 130 may perform transform on the residual block to output transform coefficients. The residual signal may mean a difference between an original signal and a predicted signal. In addition, the residual signal may mean a signal in a transformed form of a difference between the original signal and the predicted signal or may mean a signal in a transformed and quantized form of a difference between the original signal and the predicted signal. The residual signal may be referred to as a residual block in a block unit.

The quantizer 135 quantizes the transform coefficients on the basis of quantization parameters to output the quantized coefficients.

5

The entropy encoder **140** performs entropy encoding on symbols corresponding to values calculated in the quantizer **135** or encoding parameter values calculated during the encoding process according to probability distribution, thereby outputting the bit streams.

When the entropy encoding is applied, compression performance of the video encoding may be increased by allocating a smaller number of bits to symbols having high generation probability and a larger number of bits to symbols having low generation probability.

For the entropy encoding, encoding methods, such as context-adaptive variable length coding (CAVLC), context-adaptive binary arithmetic coding (CABAC), and the like, may be used. For example, the entropy encoder **140** may use a variable length coding/code (VLC) table to perform the entropy encoding. The entropy encoder **145** may also perform the entropy encoding by deriving a probability model of a binarization method of a target symbol and a target symbol/bin and then, using the derived binarization method or the probability model.

The quantized coefficients may be dequantized in the dequantizer **145** and inversely transformed in the inverse transformer **150**. The adder **155** may generate a reconstructed block using the predicted block and the inversely transformed quantized coefficients.

The filter unit **160** may apply at least one of a deblocking filter, a sample adaptive offset (SAO), an adaptive loop filter (ALF) to the reconstructed block or a reconstructed picture. The reconstructed block passing through the filter unit **160** may be stored in the reference picture buffer **165**.

FIG. 2 is a block diagram of a video decoding apparatus according to an embodiment of the present invention.

Referring to FIG. 2, a video decoding apparatus **200** includes an entropy decoder **210**, a dequantizer **220**, an inverse transformer **230**, an intra predictor **240**, a motion compensator **250**, a filter unit **260**, a reference picture buffer **270**, and an adder **280**.

The video decoding apparatus **200** may receive bit streams output from the encoder to perform the decoding with the intra mode or the inter mode and output the reconstructed video, that is, the recovered video. In the case of the intra mode, the prediction may be performed in the intra predictor **240** and in the case of the inter mode, the prediction may be performed in the motion compensator **250**. The video decoding apparatus **200** may obtain the residual block reconstructed from the received bit streams and generate the predicted block and then, add the reconstructed residual block to the predicted block to generate the reconstructed block, that is, the recovered block.

The entropy decoder **210** may perform the entropy encoding on the input bit streams according to the probability distribution to generate the symbols in the quantized coefficient type. The entropy decoding method may be performed corresponding to the above-mentioned entropy encoding method.

The quantized coefficient may be dequantized in the dequantizer **220** and is inversely transformed in the inverse transformer **230** and dequantized/inversely transformed to generate the residual block.

In the case of the intra mode, the intra predictor **240** uses sample values of the already encoded block around a current block to perform spatial prediction, thereby generating the predicted block. In the case of the inter mode, the motion compensator **250** uses a motion vector and the reference picture that is stored in the reference picture buffer **270** to perform the motion compensation, thereby generating the predicted block.

6

The adder **280** may generate the reconstructed block based on the residual block and the predicted block. The filter unit **260** may apply at least one of the deblocking filter, the SAO, and the ALF to the reconstructed block. The filter unit **260** outputs the reconstructed video, that is, the recovered video. The reconstructed video may be stored in the reference picture buffer **270** so as to be used for the inter prediction.

Constrained intra prediction (CIP) is a technology for improving robustness to errors at the time of video encoding or video decoding. The CIP technology does not use neighboring reconstructed sample regions when the reconstructed sample regions around a prediction target block used at the time of the intra prediction are inter-encoded and generates a reference sample by interpolation or extrapolation using the neighboring reconstructed samples when the reconstructed sample regions around the prediction target block are intra-encoded. The intra prediction may be performed based on the generated reference samples. Therefore, even when pictures referenced by the neighboring inter-encoded blocks are lost, the prediction target block may not be affected. However, during the deblocking filtering process according to the related art, the reconstructed video is subjected to filtering at all times regardless of whether the constrained intra prediction is applied or the encoding parameters and therefore, errors within the reconstructed video may be propagated to a region in which errors do not occur. For example, the errors occurring in the inter-encoded block may be propagated to the intra-encoded block. Therefore, the deblocking filtering process according to the related art has a problem in that a subjective quality of image of the reconstructed video may be greatly degraded.

In order to solve the above problem, a method of transmitting a flag indicating whether a constrained sample adaptive offset (SAO) compensation or a constrained adaptive loop filter (ALF) is applied may be proposed. If it is determined that the sample adaptive offset compensation or the adaptive loop filter is constrainedly applied according to the transmitted flag, the sample adaptive offset compensation or the ALF may be constrainedly applied according to the encoding parameters of the current block and the neighboring blocks. Therefore, even in the case in which the inter-encoded block cannot be normally reconstructed, the intra-encoded block can be normally decoded. That is, it is possible to prevent the error of the inter-encoded block from being propagated to the intra-encoded block and the reconstructed results of the intra-encoded block may be maintained in the encoder and the decoder.

Hereinafter, the video encoding and decoding method proposed according to an embodiment of the present invention will be described. First, the video encoding and decoding method based on the constrained sample adaptive offset compensation will be described. The sample adaptive offset compensation may be included in an in-loop filtering, and the in-loop filtering may additionally include a deblocking filter besides the sample adaptive offset compensation.

FIG. 3 shows an example of a proposed video encoding method according to an embodiment of the present invention.

In **S100**, the encoder transmits constrained offset compensation indicator to a decoder. In **S110**, the encoder transmits an SAO compensation indicator indicating whether the sample adaptive offset compensation is performed or not to the decoder. In **S120**, the encoder transmits the SAO parameter to the decoder. In **S130**, the encoder performs the sample adaptive offset compensation on the reconstructed video based on the SAO compensation indicator and the SAO parameter.

The constrained offset compensation indicator transmitted in S100 will be described.

The decoder may determine whether at least one of an encoding target sequence, a picture, a frame, a field, a slice, a coding unit (CU), a prediction unit (PU), and a transform unit (TU) supports the constrained offset compensation by the constrained offset compensation indicator transmitted from the encoder.

The encoder may transmit the constrained offset compensation indicator padded into the bit streams to the decoder. The constrained offset compensation indicator may be padded into the bit streams by the entropy coding process such as arithmetic coding, variable length coding (VLC), and the like. The constrained offset compensation indicator may be transmitted using a sequence parameter set (SPS), a picture parameter set (PPS), an adaptation parameter set (APS), a slice header, and the like, within the bit stream. The decoder may parse the bit streams by the entropy decoding process to obtain the constrained offset compensation indicator transmitted.

Table 1 shows an example of the constrained offset compensation indicator padded into the bit stream. In Table 1, the offset compensation indicator is padded into the sequence parameter set.

TABLE 1

Descriptor	
seq_parameter_set_rbsp() {	
...	
seq_parameter_set_id	ue(v)
pic_width_in_luma_samples	u(16)
pic_height_in_luma_samples	u(16)
constrained_intra_pred_flag	u(1)
constrained_offset_flag	u(1)
...	
}	

In Table 1, constrained_offset_flag represents the constrained offset compensation indicator. When a value of constrained_offset_flag is 0, it may indicate that the constrained offset compensation is not supported and when a value of constrained_offset_flag is 1, it may indicate that the constrained offset compensation is supported. Alternatively, when the value of the constrained_intra_pred_flag that is a parameter for error-resilient intra prediction is 1, it may indicate that the constrained offset compensation is supported without padding the separate offset compensation indicator.

Table 2 shows another example of the constrained offset compensation indicator padded into the bit stream. In Table 2, the constrained offset compensation indicator is padded into a picture parameter set.

TABLE 2

Descriptor	
pic_parameter_set_rbsp() {	
...	
pic_parameter_set_id	ue(v)
seq_parameter_set_id	ue(v)
constrained_offset_flag	u(1)
...	
}	

In Table 2, constrained_offset_flag represents the constrained offset compensation indicator. When the value of constrained_offset_flag is 0, it may indicate that the constrained offset compensation is not supported and when the

value of constrained_offset_flag is 1, it may indicate that the constrained offset compensation is supported.

Table 3 shows another example of the constrained offset compensation indicator padded into the bit stream. In Table 3, the constrained offset compensation indicator is padded into a picture parameter set.

TABLE 3

Descriptor	
pic_parameter_set_rbsp() {	
...	
pic_parameter_set_id	ue(v)
seq_parameter_set_id	ue(v)
loop_filter_across_tiles_enabled_flag	u(1)
loop_filter_across_slices_enabled_flag	u(1)
...	
}	

In Table 3, loop_filter_across_tiles_enabled_flag or loop_filter_across_slices_enabled_flag represents the constrained offset compensation indicator. When the value of loop_filter_across_tiles_enabled_flag is 0, it may indicate that the constrained offset compensation is supported. Or, when the value of loop_filter_across_slices_enabled_flag is 0, it may indicate that the constrained offset compensation is supported.

Alternatively, it may support the constrained offset compensation at all times in the encoder and the decoder without padding the separate offset compensation indicator.

Meanwhile, when the constrained offset compensation indicator is set to be 1 and thus, the encoder performs the constrained offset compensation, the encoder may use the encoding parameters. The encoding parameters include at least one of a coding mode indicating whether intra encoding is performed or inter encoding is performed, an intra prediction mode, an inter prediction mode, a coded block flag (CBF), a quantization parameter, a motion vector, a motion vector predictor, a reference picture index, and a slice/tile boundary or not.

For example, if the encoding parameters may include a tile boundary, and the value of the constrained offset compensation indicator is 0, the offset compensation may be constrained by not applying the offset compensation beyond the tile boundary. In this case, the constrained offset compensation indicator may be loop_filter_across_tiles_enabled_flag in Table 3. The tile boundary may be determined based on an identifier of the tile. Or, the encoding parameters may include a slice boundary, and if the value of the constrained offset compensation indicator is 0, the offset compensation may be constrained by not applying the offset compensation beyond the slice boundary. In this case, the constrained offset compensation indicator may be loop_filter_across_slices_enabled_flag in Table 3. The slice boundary may be determined based on an identifier of the slice.

For example, it may be determined whether an applied target block of the constrained offset compensation or neighboring blocks of the target block are intra-encoded or inter-encoded by using the encoding parameters. In this case, when any one of the blocks is intra-encoded, the corresponding block may be considered as being encoded with the intra mode and when any one of the blocks is inter-encoded, the corresponding block may be considered as being encoded with the inter mode. For example, when the block is encoded with pulse coded modulation (PCM), the corresponding block may be determined as being intra-encoded.

When the encoder performs the constrained offset compensation by using the encoding parameters, reliability is determined according to the encoding parameters and the determined reliability may be applied at the time of performing the constrained offset compensation. For example, as shown in Table 4, the reliability may be determined according to each encoding parameter and the reliability may also be determined according to a combination of at least one encoding parameter.

TABLE 4

Encoding Parameter	Strong Reliability	Weak Reliability
Encoding Mode	Inter	Inter
Encoding Block Flag	CBF \neq 0	CBF = 0
Quantization Parameter	QP < Specific QP	QP > Specific QP
Inter Mode	No Skip Mode	Skip Mode
Slice/tile Boundary	In Boundary	Out of Boundary

Referring to Table 4, the intra-encoded block is predicted within the current slice and therefore, may be determined as having the strong reliability and the inter-encoded block is predicted by the previous slice and therefore, may be determined as having the weak reliability. In addition, when CBF=0 or the inter mode is a skip mode, no residual signal is and therefore, it may be determined that the distortion becomes large and the reliability is weak, as compared with another block. In addition, it may be determined that the block within the slice/tile boundary has the strong reliability and the block out of the boundary has the weak reliability. If the value of the constrained offset compensation indicator in Table 3 (i.e., `loop_filter_across_tiles_enabled_flag` or `loop_filter_across_slices_enabled_flag`) is 0, "out of boundary" which has weak reliability may not be allowed.

When the constrained offset compensation is performed, in particular, the sample adaptive offset compensation may be performed. The encoder obtains the offsets by calculating errors of the sample values between the original video and the reconstructed video and applies the obtained offsets to the reconstructed video to minimize the distortion from the original video, thereby improving the performance.

The SAO compensation indicator transmitted in S110 may be transmitted, with being included in the sequence parameter set, the picture parameter set, the adaptive parameter set, the slice header, and the like. The SAO compensation indicator may be `sample_adaptive_offset_enabled_flag`. In addition, it is possible to implement signaling by including whether the sample adaptive offset compensation is performed on luma component and chroma component in each bit stream.

The SAO parameter transmitted in S120 will be described.

The SAO parameter may include at least one of an offset compensation block structure, a quadtree depth, offset types, offset categories, and offset values. The SAO parameter may include the offset compensation block structure within the bit stream. The offset compensation block structure within the SAO parameter may be `sao_split_flag`. In this case, the information regarding the offset compensation block structure may be signaled by splitting one slice into a quadtree. In addition, the information regarding the depth split into the quadtree may also be included in the bit streams and the minimum unit of the split region may be a largest coding unit (LCU).

Alternatively, the SAO parameter may include the offset types, the offset categories, the offset signs and the offset values. Table 5 shows the offset types and thus, the number of offset categories in response thereto in the sample adaptive offset compensation.

TABLE 5

Offset Type Index	Offset Type	The Number of Offset Categories
0	No Offset Performance	0
1	Edge Offset	4
2	One-dimensional 0° type edge offset	4
3	One-dimensional 90° type edge offset	4
4	One-dimensional 135° type edge offset	4
5	One-dimensional 45° type edge offset	4
5	Band Central band offset	16
6	Band Side band offset	16

Referring to Table 5, the number of offset types may be 7 in total. However, it is not limited thereto, and the number of offset types may be various. Each offset type may have offset values different from different numbers. The edge offset (EO) may be classified into four offset types according to an angle. In the edge offset, each offset type may have four offset categories by conditions. In the edge offset, the offset categories and the offset signs may be determined by comparing the offset compensation target samples with the neighboring samples. That is, in case of the edge offset, the decoder may determine the offset categories and the offset signs without additional signaling. The band offset (BO) may be classified into two offset types according to the position of the band, each of which may have 16 offset categories. In the band offset, the offset categories may be determined by dividing a range of sample values that may be included in the offset compensation target samples into 16 sections and then, may be determined according to which of the divided sections the sample values correspond to. The offset type index is encoded according to the determined offset type and may be signaled to the decoder and the offset categories and the offset signs may each be classified in the encoder and the decoder according to conditions without signaling. The determined offset categories and the offset signs may each correspond to the parsed offset values. When the offset type is determined as the edge offset, four offset values may be signaled to the decoder and when the offset type is determined as the band offset, 16 offset values may be signaled to the decoder.

Meanwhile, the SAO parameter may be determined based on the encoding parameters of at least one of the target block of the sample adaptive offset compensation and the neighboring blocks of the target block. For example, upon determining the offset categories in the edge offset type, the encoding parameters of at least one of the target block of the sample adaptive offset compensation and the neighboring blocks can be used. For example, the encoding parameters may include the tile boundary, and the tile boundary may be determined based on the identifier of the tile. Or, the encoding parameters may include the slice boundary, and the slice boundary may be determined based on the identifier of the slice.

FIG. 4 shows a type of an edge offset determined according to an angle. The edge offset may be classified into four offset types according to an angle. In FIG. 4, C represents the target samples of the sample adaptive offset compensation and N represents the neighboring samples.

FIG. 5 shows an example of a diagram showing a case in which the offset categories and the offset signs are determined in a type of an edge offset by using encoding parameters according to an embodiment of the present invention.

Referring to FIG. 5, the target block of the sample adaptive offset compensation and a left block are intra-encoded and the

11

target block and an upper block are inter-encoded. That is, in FIG. 5, C and N_1 become an intra block sample and N_2 becomes an inter block sample. Table 6 shows conditions in which the offset categories are determined and N may be N_1 or N_2 . If the offset category is determined to 1 or 2, the offset sign may be a positive number. If the offset category is determined to 3 or 4, the offset sign may be a negative number.

TABLE 6

Offset Category	Conditions
1	C is smaller than two Ns
2	C is smaller than one N and is equal to another N
3	C is larger than one N and is equal to another N
4	C is larger than two Ns
0	No applicable to the above conditions

It is assumed that the target samples of the sample adaptive offset compensation are included in the intra-encoded block and errors occur in the samples of the inter-encoded neighboring blocks. In this case, upon determining the offset categories, the offset categories may be determined only by using the intra-encoded samples within the target block without using the samples of the inter-encoded block among the neighboring blocks. This is to prevent errors from being propagated to the samples of the intra-encoded block. Alternatively, upon determining the offset categories, the offset categories may be determined by substituting the inter-encoded samples into the samples of the intra-encoded block without using the samples of the inter-encoded block among the neighboring blocks. For example, in FIG. 5, the offset categories may be determined by substituting a sample value of N_2 into a sample value of D. Alternatively, the offset categories may not be determined.

The encoder can reconstruct the offset compensated sample values by adding the calculated offset values to the sample values, based on the SAO compensation indicator and the SAO parameter. The decoder may perform the sample adaptive offset compensation by decoding each offset value and then, using the offset values corresponding to the offset categories classified by conditions for each sample within each block.

The sample adaptive offset compensation may be performed based on the encoding parameters of at least one of the target block of the sample adaptive offset compensation or the neighboring blocks of the target block. The encoding parameters may include the tile boundary, and the sample adaptive offset compensation may be performed based on the tile boundary. For example, the sample adaptive offset compensation may not be performed beyond the time boundary. Or, the encoding parameters may include the slice boundary, and the sample adaptive offset compensation may be performed based on the slice boundary. For example, the sample adaptive offset compensation may not be performed beyond the slice boundary.

Or, provided that the target samples of the sample adaptive offset compensation are included in the intra-encoded block and errors occur in the samples of the inter-encoded neighboring blocks, the sample adaptive offset compensation may be performed only by using the intra-encoded samples within the target block without using the samples of the inter-encoded block among the neighboring blocks. This is to prevent errors from being propagated to the samples of the intra-encoded block. Alternatively, upon determining the offset categories, the sample adaptive offset compensation may be performed by substituting the samples of the inter-encoded block into the samples of the intra-encoded block without

12

using the samples of the inter-encoded block among the neighboring blocks. Alternatively, the sample adaptive offset compensation may not be performed.

Describing the above processes, the encoder may split one slice into a size of various blocks having the quadtree structure, determine the optimal type using rate-distortion optimization (RDO) among the edge offset or the band offset for each block, and determine the offset types and the offset values for the determined optimal types. As described above, the SAO parameter may be entropy-encoded and then, transmitted to the decoder.

The video encoding method based on the constrained offset compensation described above may be applied to the video decoding method as it is. That is, the decoder receives and parses the constrained offset compensation indicator, the SAO compensation indicator, the SAO parameter, and the like, that are transmitted from the encoder and performs the sample adaptive offset compensation based thereon.

FIG. 6 shows an example of a proposed video decoding method according to an embodiment of the present invention.

In S200, the decoder receives the constrained offset compensation indicator from the encoder. Table 7 shows an example of the constrained offset compensation indicator padded into the picture sets.

TABLE 7

	Descriptor
pic_parameter_set_rbsp() {	
pic_parameter_set_id	ue(v)
seq_parameter_set_id	ue(v)
...	
constrained_intra_pred_flag	u(1)
if (constrained_intra_pred_flag)	
constrained_in_loop_filter_flag	u(1)
...	

In the above Table 7, when a value of constrained_intra_pred_flag is 1, that is, when the constrained intra prediction is performed, the decoder may parse constrained_in_loop_filter_flag to determine whether a constrained in-loop filter is applied. When a value of constrained_in_loop_filter_flag is 1, it may indicate that the constrained in-loop filter is applied and when the value of constrained_in_loop_filter_flag is 0, it may indicate that the constrained in-loop filter is not applied. The applied target of the constrained in-loop filter may be at least one of the deblocking filter, the offset compensation, and the ALF.

In S210, the decoder receives the SAO compensation indicator indicating whether the SAO compensation is performed or not from the encoder. The decoder may parse the SAO compensation indicator sample_adaptive_offset_enabled_flag transmitted while being included in the sequence parameter set, the picture parameter set, the adaptive parameter set, the slice header, and the like, within the bit streams to determine whether the SAO compensation is performed. In addition, the decoder may parse the information determining whether luma component and chroma component each are subjected to the SAO compensation.

In S220, the decoder receives the SAO parameter from the encoder. The decoder may parse the SAO parameter transmitted from the encoder. For example, when the SAO parameter includes sao_split_flag that is the information regarding the offset compensation block structure within the bit streams, the decoder may parse the information to determine the structure of the block performing the sample adaptive

13

offset compensation. In addition, the decoder may also parse the information regarding the depth splitting into the quadtree included in the bit streams.

When the SAO parameter includes offset types and offset categories, the offset types and the offset categories in response thereto may follow Table 5 described above. The number of offset types may be 7 in total. Each offset type may have offset values different from different numbers. When the offset type is determined as the edge offset, the decoder may parse four offset values from the bit streams and when the offset type is determined as the band offset, may parse 16 offset values from the bit streams. In addition, the offset categories according to each offset type may correspond to each parsed offset value. For example, the offset categories and the offset signs in the edge offset may be determined by comparing the offset compensation target samples with the neighboring samples and the offset categories in the band offset may be determined by dividing the range of the sample values included in the offset compensation target samples into 16 sections and then, according to which of the divided sections the sample values correspond to.

Meanwhile, when determining the offset categories according to the offset types, the target sample belongs to the intra encoded block and the neighboring samples belong to the intra encoded block, the offset category for the target sample may not be determined. That is, the value of the offset category may be set to be 0 so as not to perform the offset compensation. For example, a value of `constrained_in_loop_filter_flag` within the offset compensation indicator may be set to be 1 and when a sample located at (x,y) belongs to the intra-encoded block and at least one sample located at (x+hPos[k],y+vPos[k]) belongs to the inter-encoded block, the value of the offset category may be set to be 0. In this case, hPos[k] and vPos[k] are values representing the positions of the neighboring samples according to the offset types, which may be determined by Table 8. k=0 or 1.

TABLE 8

	Type 1	Type 2	Type 3	Type 4
hPos[0]	-1	0	-1	1
hPos[1]	1	0	1	-1
vPos[0]	0	-1	-1	-1
vPos[1]	0	1	1	1

Referring to Table 8, for example, when the offset type is 2, a value of `constrained_in_loop_filter_flag` within the offset compensation indicator may be set to be 1 and when a sample located at (x,y) belongs to the intra-encoded block and at least one sample located at (x,y+1) or (x,y-1) belongs to the inter-encoded block, the value of the offset category may be set to be '0'.

Meanwhile, when a value of the constrained offset compensation indicator is 1, and a sample located at (x,y) and at least one sample located at (x,hPos[k],y+vPos[k]) belong to different slices/tiles each other, that is, when the at least one sample located at (x,hPos[k],y+vPos[k]) is located outside of the slice/tile to which a sample located at (x,y) belongs, a value of the offset category may be set to 0. In addition, the slice/tile boundary is a boundary of a picture, the outside of the slice/tile boundary may be outside of a picture including no sample.

Meanwhile, the SAO parameter may be determined based on the encoding parameters of at least one of the target block of the sample adaptive offset compensation and the neighboring blocks of the target block.

14

In S230, the decoder performs the sample adaptive offset compensation based on the SAO compensation indicator and the SAO parameter. The decoder can reconstruct the offset compensated sample values by adding the calculated offset values to the sample values, based on the SAO compensation indicator and the SAO parameter. The sample adaptive offset compensation may be performed based on the encoding parameters of at least one of the target block of the sample adaptive offset compensation or the neighboring blocks of the target block. When the value of the offset type is set to be 0, the target sample may not be subjected to the sample adaptive offset compensation. That is, $RecSaoPicture[x,y]=RecPicture[x,y]$. The $RecSaoPicture[x,y]$ represents the sample value after the sample located at (x, y) is subjected to the sample adaptive offset compensation and the $RecPicture[x,y]$ represents the reconstructed sample value before the sample adaptive offset compensation is performed.

Hereinafter, the video encoding and decoding method will be described based on the adaptive loop filter (ALF).

FIG. 7 shows another example of a proposed video encoding method according to an embodiment of the present invention.

In S300, the encoder transmits the constrained loop filter indicator to the decoder. In S310, the encoder transmits ALF application indicator indicating whether the ALF is applied or not to the decoder. In S320, the encoder transmits the ALF parameters to the decoder. In S330, the encoder applies the ALF to the video reconstructed based on the ALF application indicator and the ALF parameters.

The constrained loop filter indicator transmitted in S300 will be described.

The decoder may determine whether at least one of the encoding target sequence, the picture, the frame, the field, the slice, the CU, the PU, and the TU applies the constrained loop filter by the constrained loop filter indicator transmitted from the encoder.

The encoder may transmit the constrained loop filter indicator padded into the bit stream to the decoder. The constrained loop filter indicator may be padded into the bit streams by the entropy encoding process such as the arithmetic encoding, the VLC, and the like. The constrained loop filter indicator may be transmitted using the SPS, the PPS, the APS, the slice header, and the like, within the bit streams. The decoder may parse the bit streams by the entropy decoding process to obtain the constrained offset compensation indicator transmitted.

Table 9 shows an example of the constrained loop filter indicator padded into the bit streams. In Table 9, the loop filter indicator is padded into the sequence parameter set.

TABLE 9

	Descriptor
<code>seq_parameter_set_rbsp() {</code>	
...	
<code>seq_parameter_set_id</code>	ue(v)
<code>pic_width_in_luma_samples</code>	u(16)
<code>pic_height_in_luma_samples</code>	u(16)
<code>constrained_intra_pred_flag</code>	u(1)
<code>constrained_filter_flag</code>	u(1)
...	
<code>}</code>	

In Table 9, `constrained_filter_flag` represents the constrained loop filter indicator. When a value of `constrained_offset_flag` is 0, it may indicate that the constrained loop filter is not applied and when a value of `constrained_offset_flag` is 1, it may indicate that the constrained loop filter is supported.

15

Alternatively, when the value of the constrained_intra_pred_flag that is a parameter for error-robust intra prediction is 1, it may indicate that the constrained loop filter is applied without padding separate loop filter indicator.

Table 10 shows another example of the constrained loop filter indicator padded into the bit streams. In Table 10, the constrained loop filter indicator is padded into the picture parameter set.

TABLE 10

		Descriptor
pic_parameter_set_rbsp() {		
...		
pic_parameter_set_id		ue(v)
seq_parameter_set_id		ue(v)
constrained_filter_flag		u(1)
...		
}		

In Table 10, constrained_filter_flag represents the constrained loop filter indicator. When a value of constrained_offset_flag is 0, it may indicate that the constrained loop filter is not applied and when a value of constrained_offset_flag is 1, it may indicate that the constrained loop filter is applied.

Or, like Table 3, loop_filter_across_tiles_enabled_flag or loop_filter_across_slices_enabled_flag may represent the constrained loop filter indicator. When the value of loop_filter_across_tiles_enabled_flag is 0, it may indicate that the constrained loop filter is applied. Or, when the value of loop_filter_across_slices_enabled_flag is 0, it may indicate that the constrained loop filter is applied.

Alternatively, it may apply the constrained loop filter at all times in the encoder and the decoder without padding the separate loop filter indicator.

Meanwhile, when the constrained loop filter indicator is set to be 1 and thus, the encoder applies the constrained loop filter, the encoder may use the encoding parameters. The encoding parameters includes at least one of the encoding mode representing whether they are intra-encoded or inter-encoded, the intra prediction mode, the inter prediction mode, the CBF, the quantization parameter, the motion vector, the motion vector predictor, the reference picture index, and the slice/tile boundary.

For example, if the encoding parameters include a tile boundary, the constrained loop filter indicator is loop_filter_across_tiles_enabled_flag in Table 3, and the value of the loop_filter_across_tiles_enabled_flag is 0, the loop filter may be constrained by not applying the loop filter beyond the tile boundary. In this case, the tile boundary may be determined based on an identifier of the tile. Or, if the encoding parameters include a slice boundary, the constrained loop filter indicator is loop_filter_across_slices_enabled_flag in Table 3, and the value of loop_filter_across_slices_enabled_flag is 0, the loop filter may be constrained by not applying the loop filter beyond the slice boundary. In this case, the slice boundary may be determined based on an identifier of the slice.

For example, it may be determined whether an applied target block of the constrained loop filter or neighboring blocks of the target block are intra-encoded or inter-encoded by using the encoding parameters. In this case, when any one of the blocks is intra-encoded, the corresponding block may be considered as being encoded with the intra mode and when any one of the blocks is inter-encoded, the corresponding block may be considered as being encoded with the inter

16

mode. In addition, for example, when the block is encoded with pulse coded modulation (PCM) mode, the corresponding block may be determined as being intra-encoded.

When the encoder applies the constrained loop filter by using the encoding parameters, the reliability is determined according to the encoding parameters and the determined reliability may be applied at the time of performing the constrained offset compensation. For example, as shown in Table 4, the reliability may be determined according to each encoding parameter and the reliability may also be determined according to a combination of at least one encoding parameter. If the value of the constrained offset compensation indicator in Table 3 (i.e., loop_filter_across_tiles_enabled_flag or loop_filter_across_slices_enabled_flag) is 0, “out of boundary” which has weak reliability may not be allowed.

When the constrained loop filter is applied, in particular, the ALF may be applied. The encoder can minimize the distortion from the original video by deriving the filter coefficients based on a Wiener filter minimizing errors between the original video and the reconstructed video and then, applying the derived filter coefficients to the reconstructed video.

The ALF application indicator transmitted in S310 may be transmitted, with being included in the sequence parameter set, the picture parameter set, the adaptive parameter set, the slice header, and the like. The ALF application indicator may be adaptive_loop_filter_flag. In addition, it is possible to implement signaling by including whether the ALF is applied to luma component and chroma component in each bit stream. In addition, it may be determined whether the ALF is applied in the CU unit or the video unit.

The ALF parameters transmitted in S320 will be described.

The ALF parameters may include at least one of a filter shape, a filter coefficient, a filter classification method, a filter index, a filter prediction method, and a filter performance maximum depth.

The encoder may determine the optimal filter shape among a plurality of filter shapes. In addition, the encoder may determine the filter coefficients used to apply the ALF. In this case, the filter coefficient may be one or more and may be encoded with other order exponential Golomb codes. In order to effectively encode the filter coefficient, the prediction encoding may be performed between the filter coefficients by methods such as differential pulse code modulation (DPCM), and the like, and any one of the filter coefficients may also be subjected to the prediction encoding from a sum of other filter coefficients. In addition, if it is determined that the ALF is applied, the filter may be selected using one of region-based adaptation (RA) and block-based adaptation (BA) as the filter classification method. For example, when the filter classification method is determined as the RA method, a value of alf_region_adaptation_flag is set to be 1 and when the filter classification method is determined as the BA method, the value of alf_region_adaptation_flag is set to be 0. When the RA method is used, any one of the plurality of filters per the split video region may be selected and when the BA method is used, any one of the plurality of filters may be selected in consideration of variations and directivity of samples. In this case, in order to indicate which filter is selected, the filter index within the ALF parameters may be used. In addition, the ALF may be applied only to the CU of the specific depth by padding the information regarding the maximum depth to which the ALF is applied into the bit streams.

FIG. 8 shows an example of a filter shape determined by an encoder in the proposed video encoding method according to an embodiment of the present invention. Referring to FIG. 8, numbers within each filter represents the filter coefficient index. The encoder transmits the information regarding the

filter shape and the filter classification method included in the ALF parameters to the decoder and the filter is selected according to the determined filter classification method. A maximum of 16 filters may be present. When the filtering is performed based on the selected filter, the filtering may be performed by a sum of a product of each filter coefficient and the sample values corresponding to each position upon filtering the sample values positioned at the center of the filter shape.

Meanwhile, when the filter is classified based on the BA method, the encoding parameters of at least one of the ALF applied target block and the neighboring blocks may be used. For example, the encoding parameters may include the tile boundary, and the tile boundary may be determined based on an identifier of the tile. Or, the encoding parameters may include the slice boundary, and the slice boundary may be determined based on an identifier of the slice.

FIG. 9 shows a case in which a filter is classified based on a BA method by using encoding parameters in the proposed video encoding method according to an embodiment of the present invention. For example, in the case in which the ALF applied target block is intra-encoded and the neighboring blocks are inter-encoded, when horizontal or vertical directivity is determined in a 4×4 block unit, the samples within the 4×4 blocks that are not shaded in FIG. 9 become the samples of the intra block and the samples that are shaded may be the samples of the inter block. In addition, 'R' represents the reconstructed sample, VA represents vertical directivity, and HA represents horizontal directivity.

For example, it is assumed that the ALF applied target sample is included in the intra-encoded block and errors occur in the samples of the inter-encoded neighbor blocks, based on the BA method. In this case, the filter can be classified only by using the intra-encoded samples within the target block without using the samples of the inter-encoded block among the neighboring blocks. This is to prevent errors from being propagated to the samples of the intra-encoded block. Alternatively, the filter may be classified by substituting the samples of the inter-encoded block into the samples of the intra-encoded block without using the samples of the inter-encoded block among the neighboring blocks. For example, when the horizontal or vertical directivity is determined at position 'R_(0,0)' in FIG. 9, the 'R_(-1,0)' or 'R_(0,-1)' value included in the inter block is substituted into the value of the intra block and then, the directivity may be determined. Alternatively, the filter may not be classified.

FIG. 10 shows an example of a case in which an ALF is applied using the encoding parameters in the proposed video encoding method according to an embodiment of the present invention.

Even when the ALF is applied, the ALF may be determined based on the encoding parameters of at least one of the ALF applied target block or the neighboring blocks of the target block. The encoding parameters may include the tile boundary, and the ALF may be applied based on the tile boundary. For example, the ALF may not be applied beyond the time boundary. Or, the encoding parameters may include the slice boundary, and the ALF may be applied based on the slice boundary. For example, the ALF may not be performed beyond the slice boundary.

Or, provided that the ALF applied target samples are included in the intra-encoded block and errors occur in the samples of the inter-encoded neighboring blocks, the ALF may be applied only by using the intra-encoded samples within the target block or among the neighboring blocks without using the samples of the inter-encoded block among the neighboring blocks. This is to prevent errors from being

propagated to the samples of the intra-encoded block. When the filter shape of FIG. 8(a) is applied to the 4×4 block of FIG. 10(a), the position of the filtering target sample is number 9 at the center and the filter is applied using the neighboring sample values and the filter coefficients of the corresponding positions. In this case, as shown in FIG. 10(b), only when the filter coefficient is included in the intra-encoded block, the filter is applied. That is, the filter may be applied only to sample values i, j, k, l, m, n, o, and p. Alternatively, the ALF may be applied by substituting the samples of the inter-encoded block into the samples of the intra-encoded block without using the samples of the inter-encoded block among the neighboring blocks. Alternatively, the ALF may not be applied.

The encoder may apply the ALF based on the ALF application indicator and the ALF parameters. The ALF may be applied based on the encoding parameters of at least one of the ALF applied target block or the neighboring blocks of the target block.

Describing the above-mentioned process, the encoder synchronizes one slice with a coding tree block structure, determines whether the filter is performed in the CU unit, the filter performance maximum depth, the filter prediction method, the filter classification method, the filter shape, the filter coefficient, and the like, using the RDO, and may apply the ALF using the determined optimal ALF parameters. As described above, the ALF parameter may be entropy-encoded and then, transmitted to the decoder.

The video encoding method based on the constrained loop filter described above may be applied to the video decoding method as it is. That is, the decoder receives and parses the constrained loop filter indicator, the ALF application indicator, the ALF parameter, and the like, that are transmitted from the encoder and applies the ALF based thereon.

FIG. 11 shows another example of a proposed video decoding method according to an embodiment of the present invention.

In S400, the decoder receives the constrained loop filter indicator from the encoder. Table 11 shows an example of the constrained loop filter indicator padded into a set of the picture parameters.

TABLE 11

	Descriptor
pic_parameter_set_rbsp() {	
pic_parameter_set_id	ue(v)
seq_parameter_set_id	ue(v)
...	
constrained_intra_pred_flag	u(1)
if (constrained_intra_pred_flag)	
constrained_in_loop_filter_flag	u(1)
...	

In the above Table 11, when the value of constrained_intra_pred_flag is 1, that is, when the constrained intra prediction is performed, the decoder may parse the constrained_in_loop_filter_flag to determine whether the constrained in-loop filter is applied. When the value of constrained_in_loop_filter_flag is 1, it may indicate that the constrained in-loop filter is applied and when the value of constrained_in_loop_filter_flag is 0, it may indicate that the constrained in-loop filter is not applied. The applied target of the constrained in-loop filter may be at least one of the deblocking filter, the offset compensation, and the ALF.

In S410, the decoder receives the ALF application indicator indicating whether the ALF is applied from the encoder.

The decoder may parse the ALF application indicator adaptive_loop_filter_enabled_flag transmitted while being included in the sequence parameter set, the picture parameter set, the adaptive parameter set, the slice header, and the like, within the bit streams to determine whether the ALF is applied. In addition, the decoder may parse the information regarding whether the ALF is applied to the luma component and the chroma component, respectively, whether the ALF in the CU unit is applied, and the like, from the bit streams.

In S420, the decoder receives the ALF parameters from the encoder.

The decoder may parse the ALF parameter transmitted from the encoder. The ALF parameters may include at least one of the filter shape, the filter coefficient, the filter classification method, the filter index, the filter prediction method, and the filter performance maximum depth. For example, the decoder may parse the bit streams to determine the filter shape and/or the filter coefficient. In this case, the number of filter coefficient may be one or more and may be decoded with other order exponential Golomb code. Further, in order to efficiently decode the filter coefficients, the prediction decoding may be performed between the filter coefficients by the methods such as DPCM, and the like, and any one of the filter coefficients may be prediction-decoded from the sum of other filter coefficients. In addition, the filter may be differently selected by using one of the RA method and the BA method as the filter classification method. For example, when the alf_region_adaptation_flag parsed by the encoder is set to be '1', the filter may be classified by the RA method and when the alf_region_adaptation_flag is set to be '0', the filter may be classified by the BA method. When the RA method is used, any one of the plurality of filters per the split video region may be selected and when the BA method is used, any one of the plurality of filters may be selected in consideration of variations and directivity of samples. In this case, in order to indicate which filter is selected, the filter index within the ALF parameters may be used.

When the block to which the applied target sample of the ALF belongs is intra-encoded and the block to which the neighboring samples belong is inter-encoded, a horizontal or vertical directivity may be determined by using only the samples of the intra block and the filter corresponding thereto may be determined. For example, Equation of FIG. 9 may be applied at positions $R_{(0,0)}$ and $R_{(0,2)}$ and $R_{(2,0)}$ and $R_{(2,2)}$ so as to determine the directivity in FIG. 9. In FIG. 9, when a portion to which a shadow is applied is inter-encoded and a white portion is intra-encoded, the decoder may determine the directivity at only $R_{(2,2)}$ position in which all of the applied target sample and the neighboring pixels of the ALF belong to a screen and the filter to be applied.

Meanwhile, the ALF parameters may be determined based on the encoding parameters of at least one of the ALF applied target block or the neighboring blocks of the target block.

In S430, the decoder performs the ALF based on the ALF application indicator and the ALF parameters. The decoder may apply the ALF based on the ALF application indicator and the ALF parameters. The ALF may be applied based on the encoding parameters of at least one of the ALF applied target block or the neighboring blocks of the target block. When the block to which the applied target sample of the ALF belongs is intra-encoded and the neighboring samples belong to the inter-encoded block, the applied target sample of the ALF may not be subjected to the ALF.

FIG. 12 shows an example of a filter shape used in the proposed video decoding method according to an embodiment of the present invention. In the filter shape as shown in FIG. 12, in the case in which the ALF is applied to the sample

of position '9', the ALF may not be applied to the target sample when at least one sample around the applied target sample belongs to the inter-encoded block.

The present invention may be implemented by hardware and software or a combination thereof. Hardware may be implemented by an application specific integrated circuit (ASIC), digital signal processing (DSP), a programmable logic device (PLD), a field programmable gate array (FPGA), a processor, a controller, a microprocessor, other electronic units, or a combination thereof that are designed to perform the above-mentioned functions. Software may be implemented by a module performing the above-mentioned function. The software may be stored in the memory unit and executed by the processor. As the memory unit or the processor, various units well-known to those skilled in the art may be adopted.

The exemplary embodiments of the present invention can apply the offset compensation or loop filter so as to withstand errors at the time of encoding and decoding video.

In the above-mentioned exemplary system, although the methods have described based on a flow chart as a series of steps or blocks, the present invention is not limited to a sequence of steps but any step may be generated in a different sequence or simultaneously from or with other steps as described above. Further, it may be appreciated by those skilled in the art that steps shown in a flow chart is non-exclusive and therefore, include other steps or deletes one or more steps of a flow chart without having an effect on the scope of the present invention.

The invention claimed is:

1. A method for decoding a video, the method comprising: receiving a first constrained offset compensation indicator and a second constrained offset compensation indicator from an encoding apparatus, wherein the first constrained offset compensation indicator indicates whether constrained offset compensation across tile boundaries can be applied or not, and the second constrained offset compensation indicator indicates whether constrained offset compensation across slice boundaries can be applied or not; receiving a sample adaptive offset (SAO) compensation indicator from the encoding apparatus, wherein the SAO compensation indicator indicates whether to perform SAO compensation; receiving a SAO parameter from the encoding apparatus when the SAO compensation indicator indicates performing SAO compensation; and performing SAO compensation, using the SAO compensation indicator and the SAO parameter, on a sample across tile when the first constrained offset compensation indicator indicates that constrained offset compensation across tile boundaries are not applied and across slice when the second constrained offset compensation indicator indicates that constrained offset compensation across slice boundaries are not applied, wherein the performing SAO compensation comprises determining an offset category for the SAO compensation based on the first constrained offset compensation indicator, the second constrained offset compensation indicator, and encoding parameters of a target block of the SAO compensation, and at least one of neighboring blocks of the target block upon an edge offset being applied to an offset compensation target sample within the target block.
2. The method of claim 1, wherein the first constrained offset compensation indicator and the second constrained

21

offset compensation indicator are included in a sequence parameter set (SPS), a picture parameter set (PPS), or a slice header within a bit stream.

3. The method of claim 1, wherein the SAO compensation indicator is included in a sequence parameter set (SPS), a picture parameter set (PPS), or slice header within a bit stream.

4. The method of claim 1, wherein the SAO parameter comprises an offset type, an offset kind, an offset value, or an offset sign.

5. The method of claim 1, wherein the SAO compensation indicator is received with respect to each of a luma component and chroma component.

6. An apparatus for decoding video, the apparatus comprising:

- a decoder to receive and decode a first constrained offset compensation indicator indicating whether a tile supports constrained offset compensation, a second constrained offset compensation indicator indicating whether a slice supports constrained offset compensation, a sample adaptive offset (SAO) compensation indicator indicating whether to preform SAO compensation, and a SAO parameter from an encoding apparatus; and
- a filter unit to perform SAO compensation on a target sample of a target block of reconstructed video based on the SAO compensation indicator and the SAO parameter,

22

wherein the filter unit determines an offset category for the SAO compensation based on the first constrained offset compensation indicator, the second constrained offset compensation indicator, and encoding parameters of the target block of the SAO compensation, and at least one of neighboring blocks of the target block upon an edge offset being applied to an offset compensation target sample within the target block.

7. The apparatus of claim 6, wherein the first constrained offset compensation indicator and the second constrained offset compensation indicator are included in a sequence parameter set (SPS), a picture parameter set (PPS), or a slice header within a bit stream.

8. The apparatus of claim 6, wherein the SAO compensation indicator is included in a sequence parameter set (SPS), a picture parameter set (PPS), or a slice header within a bit stream.

9. The apparatus of claim 6, wherein the SAO parameter comprises an offset type, an offset kind, and offset value, or and offset sign.

10. The apparatus of claim 6, wherein the SAO compensation indicator is received with respect to each of a luma component and chroma component.

* * * * *