



US009270764B2

(12) **United States Patent**
Fernández

(10) **Patent No.:** **US 9,270,764 B2**
(45) **Date of Patent:** ***Feb. 23, 2016**

(54) **METHODS FOR TRANSMITTING MULTIMEDIA FILES AND ADVERTISEMENTS**

30/0277 (2013.01); **H04L 65/4092** (2013.01);
H04N 7/17318 (2013.01); **H04N 21/4331**
(2013.01); **H04N 21/6125** (2013.01); **H04N**
21/6437 (2013.01); **H04N 21/6543** (2013.01);
H04N 21/812 (2013.01); **H04L 65/602**
(2013.01)

(75) Inventor: **Alvaro Fernández**, Barcelona (ES)

(73) Assignee: **TAMIRAS PER PTE LTD., LLC**,
Dover, DE (US)

(*) Notice: Subject to any disclaimer, the term of this patent is extended or adjusted under 35 U.S.C. 154(b) by 1143 days.

This patent is subject to a terminal disclaimer.

(58) **Field of Classification Search**

USPC 709/231, 245; 386/68, 124; 725/34;
705/51

See application file for complete search history.

(56) **References Cited**

U.S. PATENT DOCUMENTS

4,866,769 A 9/1989 Karp
4,916,747 A 4/1990 Arimoto

(Continued)

FOREIGN PATENT DOCUMENTS

EP 1243998 A1 9/2002
EP 1641263 A2 3/2006

(Continued)

OTHER PUBLICATIONS

International Preliminary Report on Patentability dated Oct. 14, 2010 for PCT/ES2009/070064; International Bureau of WIPO.

(Continued)

Primary Examiner — Quang N Nguyen

(74) *Attorney, Agent, or Firm* — Fitch, Even, Tabin & Flannery LLP

(21) Appl. No.: **13/250,041**

(22) Filed: **Sep. 30, 2011**

(65) **Prior Publication Data**

US 2012/0035994 A1 Feb. 9, 2012

Related U.S. Application Data

(63) Continuation of application No. 13/157,175, filed on Jun. 9, 2011, now Pat. No. 8,090,774, which is a continuation of application No. 12/702,168, filed on Feb. 8, 2010, now Pat. No. 7,984,097, which is a continuation-in-part of application No. 12/431,553, filed on Apr. 28, 2009, now Pat. No. 8,185,625, which is a continuation of application No. 12/203,142, filed on Sep. 2, 2008, now Pat. No. 7,565,429.

(30) **Foreign Application Priority Data**

Mar. 18, 2008 (ES) 200800783

(51) **Int. Cl.**

G06F 15/16 (2006.01)

G06F 15/173 (2006.01)

(Continued)

(52) **U.S. Cl.**

CPC **H04L 67/20** (2013.01); **G06Q 30/02**

(2013.01); **G06Q 30/0241** (2013.01); **G06Q**

(57) **ABSTRACT**

In one implementation a process is provided that upon a server determining that the playing of all or part of an obligatory advertising portion is attempting to be avoided by a multimedia player, the server sends to the multimedia player a message with data storage medium control information for the purpose of inhibiting advertising-sponsored content stored in a data storage medium from being played by multimedia player.

28 Claims, 13 Drawing Sheets

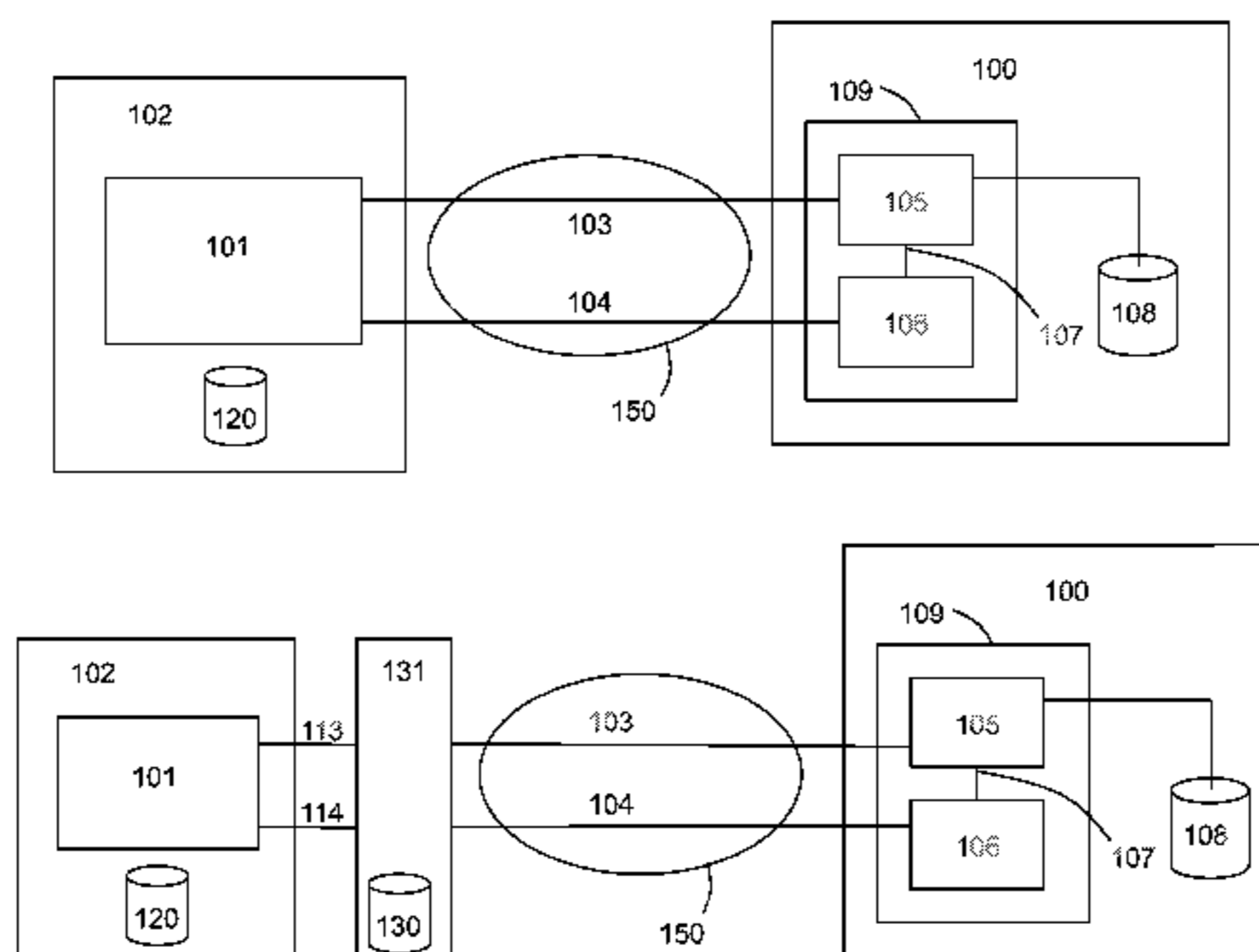

| | | | | | | | |
|------|---------------------|-----------|-----------|-----|---------|---------------------|---------|
| (51) | Int. Cl. | | | | | | |
| | H04L 29/08 | (2006.01) | 7,155,415 | B2 | 12/2006 | Russell et al. | |
| | G06Q 30/02 | (2012.01) | 7,171,662 | B1 | 1/2007 | Misra et al. | |
| | H04N 7/173 | (2011.01) | 7,188,342 | B2 | 3/2007 | DeMello et al. | |
| | H04N 21/433 | (2011.01) | 7,200,575 | B2 | 4/2007 | Hans et al. | |
| | H04N 21/61 | (2011.01) | 7,203,758 | B2 | 4/2007 | Cook et al. | |
| | H04N 21/6437 | (2011.01) | 7,222,078 | B2 | 5/2007 | Abelow | |
| | H04N 21/6543 | (2011.01) | 7,249,060 | B2 | 7/2007 | Ling | |
| | H04N 21/81 | (2011.01) | 7,277,870 | B2 | 10/2007 | Mourad et al. | |
| | H04L 29/06 | (2006.01) | 7,292,773 | B2 | 11/2007 | Angel | |
| | | | 7,356,557 | B2 | 4/2008 | Kikuchi et al. | |
| | | | 7,373,391 | B2 | 5/2008 | Iinuma | |
| | | | 7,395,244 | B1 | 7/2008 | Kingsford | |
| | | | 7,516,493 | B2 | 4/2009 | Matsuyama et al. | |
| | | | 7,523,071 | B2 | 4/2009 | Fox et al. | |
| | | | 7,565,429 | B1 | 7/2009 | Fernandez Gutierrez | |
| | | | 7,574,486 | B1 | 8/2009 | Cheng et al. | |
| | | | 7,593,902 | B2 | 9/2009 | Murase | |
| | | | 7,603,409 | B2 | 10/2009 | Kobayashi et al. | |
| | | | 7,636,792 | B1 | 12/2009 | Ho | |
| | | | 7,640,333 | B1 | 12/2009 | Fernandez Gutierrez | |
| | | | 7,653,198 | B2 | 1/2010 | Sako et al. | |
| | | | 7,707,115 | B2 | 4/2010 | Goringe et al. | |
| | | | 7,743,161 | B2 | 6/2010 | Dey et al. | |
| | | | 7,747,466 | B2 | 6/2010 | Fernandez | |
| | | | 7,809,790 | B2 | 10/2010 | Fernandez Gutierrez | |
| | | | 7,856,645 | B2* | 12/2010 | Pharn | 709/231 |
| | | | 7,860,963 | B2 | 12/2010 | Matsuoka et al. | |
| | | | 7,882,037 | B2 | 2/2011 | Hirsch | |
| | | | 7,908,354 | B2 | 3/2011 | Fernández Gutiérrez | |
| | | | 7,921,198 | B2 | 4/2011 | Fernández Gutiérrez | |
| | | | 7,962,548 | B2 | 6/2011 | Fernandez | |
| | | | 7,966,411 | B2 | 6/2011 | Fernandez | |
| | | | 7,984,097 | B2 | 7/2011 | Fernandez | |
| | | | 7,984,174 | B2 | 7/2011 | Rideout | |
| | | | 8,028,064 | B2 | 9/2011 | Fernandez | |
| | | | 8,055,781 | B2 | 11/2011 | Fernandez | |
| | | | 8,064,449 | B2 | 11/2011 | Fernández Gutiérrez | |
| | | | 8,086,716 | B2 | 12/2011 | Fernández Gutiérrez | |
| | | | 8,090,774 | B2 | 1/2012 | Fernández | |
| | | | 8,094,602 | B2 | 1/2012 | Fernández Gutiérrez | |
| | | | 8,185,625 | B2 | 5/2012 | Fernandez | |
| | | | 8,185,626 | B2 | 5/2012 | Fernandez | |
| | | | 8,422,499 | B2 | 4/2013 | Fernández Gutierrez | |
| | | | 8,769,149 | B2* | 7/2014 | Sidi et al. | 709/245 |
| | | | 8,868,464 | B2* | 10/2014 | Zhuk et al. | 705/51 |

(56) **References Cited**

U.S. PATENT DOCUMENTS

| | | | | | | | |
|--------------|----|---------|---------------------|--|---------|-------------------|--|
| 4,953,209 | A | 8/1990 | Ryder et al. | | | | |
| 5,247,575 | A | 9/1993 | Sprague et al. | | | | |
| 5,297,071 | A | 3/1994 | Sugino | | | | |
| 5,629,980 | A | 5/1997 | Stefik | | | | |
| 5,671,412 | A | 9/1997 | Christiano | | | | |
| 5,708,709 | A | 1/1998 | Rose | | | | |
| 5,790,664 | A | 8/1998 | Coley et al. | | | | |
| 5,815,665 | A | 9/1998 | Teper et al. | | | | |
| 5,855,008 | A | 12/1998 | Goldhaber et al. | | | | |
| 5,864,620 | A | 1/1999 | Pettitt | | | | |
| 5,870,559 | A | 2/1999 | Leshem et al. | | | | |
| 6,009,525 | A | 12/1999 | Horstmann | | | | |
| 6,073,124 | A | 6/2000 | Krishnan et al. | | | | |
| 6,078,909 | A | 6/2000 | Knutson | | | | |
| 6,189,146 | B1 | 2/2001 | Misra et al. | | | | |
| 6,226,618 | B1 | 5/2001 | Downs et al. | | | | |
| 6,237,006 | B1 | 5/2001 | Weinberg et al. | | | | |
| 6,247,130 | B1 | 6/2001 | Fritsch | | | | |
| 6,282,653 | B1 | 8/2001 | Berstis et al. | | | | |
| 6,324,658 | B1 | 11/2001 | Jasperneite et al. | | | | |
| 6,363,356 | B1 | 3/2002 | Horstmann | | | | |
| 6,389,403 | B1 | 5/2002 | Dorak, Jr. | | | | |
| 6,389,432 | B1 | 5/2002 | Pothapragada et al. | | | | |
| 6,434,535 | B1 | 8/2002 | Kupka | | | | |
| 6,436,230 | B1 | 8/2002 | Kondo et al. | | | | |
| 6,452,903 | B1 | 9/2002 | Peck et al. | | | | |
| 6,484,182 | B1 | 11/2002 | Dunphy et al. | | | | |
| 6,505,169 | B1 | 1/2003 | Bhagavath et al. | | | | |
| 6,522,866 | B1 | 2/2003 | Merkle et al. | | | | |
| 6,535,871 | B1 | 3/2003 | Romansky et al. | | | | |
| 6,587,837 | B1 | 7/2003 | Spagna et al. | | | | |
| 6,640,093 | B1 | 10/2003 | Wildhagen | | | | |
| 6,654,754 | B1 | 11/2003 | Knauff et al. | | | | |
| 6,697,944 | B1 | 2/2004 | Jones et al. | | | | |
| 6,704,733 | B2 | 3/2004 | Clark et al. | | | | |
| 6,766,064 | B1 | 7/2004 | Langan et al. | | | | |
| 6,772,340 | B1 | 8/2004 | Peinado et al. | | | | |
| 6,775,655 | B1 | 8/2004 | Peinado et al. | | | | |
| 6,871,220 | B1 | 3/2005 | Rajan et al. | | | | |
| 6,947,981 | B2 | 9/2005 | Lubbers et al. | | | | |
| 6,981,217 | B1 | 12/2005 | Knauff et al. | | | | |
| 6,990,512 | B1 | 1/2006 | Major et al. | | | | |
| 6,996,544 | B2 | 2/2006 | Sellars et al. | | | | |
| 7,007,042 | B2 | 2/2006 | Lubbers et al. | | | | |
| 7,024,393 | B1 | 4/2006 | Peinado et al. | | | | |
| 7,036,011 | B2 | 4/2006 | Grimes et al. | | | | |
| 7,051,005 | B1 | 5/2006 | Peinado et al. | | | | |
| 7,054,443 | B1 | 5/2006 | Jakubowski et al. | | | | |
| 7,065,507 | B2 | 6/2006 | Mohammed et al. | | | | |
| 7,069,271 | B1 | 6/2006 | Fadel et al. | | | | |
| 7,076,468 | B2 | 7/2006 | Hillegass et al. | | | | |
| 7,103,351 | B2 | 9/2006 | Chaudhari et al. | | | | |
| 7,103,574 | B1 | 9/2006 | Peinado et al. | | | | |
| 7,103,645 | B2 | 9/2006 | Leighton et al. | | | | |
| 7,110,982 | B2 | 9/2006 | Feldman et al. | | | | |
| 7,120,250 | B2 | 10/2006 | Candelore | | | | |
| 7,120,429 | B2 | 10/2006 | Minear et al. | | | | |
| 7,124,301 | B1 | 10/2006 | Uchida | | | | |
| 7,124,302 | B2 | 10/2006 | Ginter et al. | | | | |
| 7,142,566 | B1 | 11/2006 | Leyn et al. | | | | |
| 7,149,722 | B1 | 12/2006 | Abhuri | | | | |
| 7,152,091 | B2 | 12/2006 | Kuriyama | | | | |
| 2001/0014876 | A1 | | | | 8/2001 | Miyashita | |
| 2001/0044851 | A1 | | | | 11/2001 | Rothman et al. | |
| 2002/0053078 | A1 | | | | 5/2002 | Holtz et al. | |
| 2002/0073084 | A1 | | | | 6/2002 | Kauffman et al. | |
| 2002/0091570 | A1 | | | | 7/2002 | Sakagawa | |
| 2002/0091584 | A1 | | | | 7/2002 | Clark et al. | |
| 2002/0097728 | A1 | | | | 7/2002 | Hinderks et al. | |
| 2002/0107809 | A1 | | | | 8/2002 | Biddle et al. | |
| 2002/0116517 | A1 | | | | 8/2002 | Hudson et al. | |
| 2002/0133518 | A1 | | | | 9/2002 | Landsman et al. | |
| 2002/0138441 | A1 | | | | 9/2002 | Lopatic | |
| 2002/0169833 | A1 | | | | 11/2002 | Tani et al. | |
| 2002/0188523 | A1 | | | | 12/2002 | Hyypa et al. | |
| 2003/0007646 | A1 | | | | 1/2003 | Hurst et al. | |
| 2003/0046367 | A1 | | | | 3/2003 | Tanaka | |
| 2003/0050887 | A1 | | | | 3/2003 | Geiger | |
| 2003/0051237 | A1 | | | | 3/2003 | Sako et al. | |
| 2003/0120557 | A1 | | | | 6/2003 | Evans et al. | |
| 2003/0149975 | A1 | | | | 8/2003 | Eldering et al. | |
| 2003/0185399 | A1 | | | | 10/2003 | Ishiguro | |
| 2003/0188317 | A1 | | | | 10/2003 | Liew et al. | |
| 2003/0223094 | A1 | | | | 12/2003 | Naito | |
| 2003/0236756 | A1 | | | | 12/2003 | Humpleman et al. | |
| 2004/0003398 | A1 | | | | 1/2004 | Donian et al. | |
| 2004/0059708 | A1 | | | | 3/2004 | Dean et al. | |
| 2004/0088349 | A1 | | | | 5/2004 | Beck et al. | |
| 2004/0093327 | A1 | | | | 5/2004 | Anderson et al. | |
| 2004/0098344 | A1 | | | | 5/2004 | Nakanishi et al. | |
| 2004/0139204 | A1 | | | | 7/2004 | Ergezinger et al. | |
| 2004/0143667 | A1 | | | | 7/2004 | Jerome | |
| 2004/0148229 | A1 | | | | 7/2004 | Maxwell | |
| 2004/0148424 | A1 | | | | 7/2004 | Berkson et al. | |
| 2004/0205114 | A1 | | | | 10/2004 | Kinoshita | |
| 2004/0255135 | A1 | | | | 12/2004 | Kitaya et al. | |

(56)

References Cited

U.S. PATENT DOCUMENTS

2005/0004873 A1 1/2005 Pou et al.
 2005/0021467 A1 1/2005 Franzdonk
 2005/0034171 A1 2/2005 Benya
 2005/0076104 A1 4/2005 Liskov et al.
 2005/0091166 A1 4/2005 Seamans
 2005/0114205 A1 5/2005 Nelson et al.
 2005/0144136 A1 6/2005 Murashita
 2005/0146966 A1 7/2005 Kawamura
 2005/0251489 A1 11/2005 Coley et al.
 2005/0288999 A1 12/2005 Lerner et al.
 2006/0013557 A1 1/2006 Poslinski
 2006/0031175 A1 2/2006 Sellars et al.
 2006/0031892 A1 2/2006 Cohen
 2006/0059223 A1 3/2006 Klemets et al.
 2006/0089912 A1 4/2006 Spagna et al.
 2006/0095792 A1 5/2006 Hurtado et al.
 2006/0136967 A1 6/2006 Hellman
 2006/0143135 A1 6/2006 Tucker et al.
 2006/0167812 A1 7/2006 Bhambri et al.
 2006/0218602 A1 9/2006 Sherer et al.
 2006/0251387 A1* 11/2006 Tanikawa et al. 386/68
 2006/0277098 A1 12/2006 Chung et al.
 2007/0005804 A1 1/2007 Rideout
 2007/0038567 A1 2/2007 Allaire et al.
 2007/0067495 A1 3/2007 Levy
 2007/0083886 A1 4/2007 Kauffman et al.
 2007/0094691 A1 4/2007 Gazdzinski
 2007/0118849 A1 5/2007 Kisel et al.
 2007/0138849 A1* 6/2007 Olarte 297/257
 2007/0140318 A1 6/2007 Hellman
 2007/0155204 A1 7/2007 Klitsner et al.
 2007/0162560 A1 7/2007 Jin
 2007/0168294 A1 7/2007 Tsurukawa
 2007/0220430 A1 9/2007 Sato
 2007/0244823 A1 10/2007 Motley et al.
 2007/0282714 A1 12/2007 Aydar et al.
 2007/0294772 A1 12/2007 Hydrie et al.
 2008/0019516 A1 1/2008 Fransdonk
 2008/0022347 A1 1/2008 Cohen
 2008/0027750 A1 1/2008 Barkeloo et al.
 2008/0069099 A1 3/2008 Tani et al.
 2008/0077478 A1 3/2008 Kim
 2008/0086570 A1 4/2008 Dey et al.
 2008/0092168 A1 4/2008 Logan et al.
 2008/0092182 A1 4/2008 Conant
 2008/0114695 A1 5/2008 Fernandez Gutierrez
 2008/0141307 A1 6/2008 Whitehead et al.
 2008/0152316 A1* 6/2008 Sylvain 386/124
 2008/0172300 A1 7/2008 Karki et al.
 2008/0177630 A1 7/2008 Maghfourian et al.
 2008/0189429 A1 8/2008 DaCosta
 2008/0195761 A1 8/2008 Jabri et al.
 2008/0242280 A1 10/2008 Shapiro et al.
 2008/0249872 A1 10/2008 Russell et al.
 2008/0250029 A1 10/2008 Fernandez
 2008/0255943 A1 10/2008 Morten et al.
 2008/0288976 A1 11/2008 Carson et al.
 2008/0320605 A1 12/2008 Ben-Yaacov et al.
 2009/0083144 A1 3/2009 Menditto et al.
 2009/0165041 A1* 6/2009 Penberthy et al. 725/34
 2009/0204541 A1 8/2009 Zhuk et al.
 2009/0205031 A1 8/2009 Sato et al.
 2009/0210899 A1 8/2009 Lawrence-Apfelbaum et al.
 2009/0222530 A1 9/2009 Buford et al.
 2009/0240768 A1 9/2009 Fernandez Gutierrez
 2009/0240786 A1 9/2009 Fernandez Gutierrez
 2009/0240827 A1 9/2009 Fernandez Gutierrez
 2009/0240828 A1 9/2009 Fernandez Gutierrez
 2009/0240830 A1 9/2009 Fernandez Gutierrez
 2009/0259764 A1 10/2009 Karlsson et al.
 2009/0286560 A1 11/2009 Willis
 2010/0031162 A1 2/2010 Wiser et al.
 2010/0046516 A1 2/2010 Fernández Gutiérrez
 2010/0064054 A1 3/2010 Karlsson et al.
 2010/0070355 A1 3/2010 Fernandez Gutierrez

2010/0076827 A1 3/2010 Fernandez Gutierrez
 2010/0082835 A1 4/2010 Fernandez Gutierrez
 2010/0153231 A1 6/2010 Fernandez Gutierrez
 2010/0153873 A1 6/2010 Gutierrez
 2010/0172352 A1 7/2010 Fernández Gutierrez
 2010/0172353 A1 7/2010 Fernández Gutierrez
 2010/0198982 A1 8/2010 Fernandez Gutierrez
 2010/0228647 A1 9/2010 Fernandez Gutierrez
 2010/0235237 A1 9/2010 Fernandez Gutierrez
 2010/0235262 A1 9/2010 Fernandez Gutierrez
 2010/0235263 A1 9/2010 Fernandez Gutierrez
 2010/0235264 A1 9/2010 Fernandez Gutierrez
 2010/0235265 A1 9/2010 Fernandez Gutierrez
 2010/0250400 A1 9/2010 Fernandez Gutierrez
 2010/0257051 A1 10/2010 Fernandez Gutierrez
 2010/0274664 A1 10/2010 Fernandez Gutierrez
 2011/0016498 A1 1/2011 Tsuria et al.
 2011/0060688 A1 3/2011 Fernandez Gutierrez
 2011/0060689 A1 3/2011 Fernandez Gutierrez
 2011/0078044 A1 3/2011 Fernandez Gutierrez
 2011/0137738 A1 6/2011 Fernandez Gutierrez
 2011/0137754 A1 6/2011 Fernandez Gutierrez
 2012/0323651 A1 12/2012 Fernández

FOREIGN PATENT DOCUMENTS

JP 2002175436 A 6/2002
 JP 2003186905 A 7/2003
 JP 2003256670 A 9/2003
 JP 2003288130 A 10/2003
 KR 2003075948 A 9/2003
 WO 2006086717 A1 8/2006
 WO 2006138432 A2 12/2006
 WO 2008055562 5/2008
 WO 2008055562 A1 5/2008
 WO 2008122308 A1 10/2008
 WO 2009000306 12/2008
 WO 2009049659 4/2009
 WO 2009056175 5/2009
 WO 2009065526 A1 5/2009
 WO 2009095041 8/2009
 WO 2009109684 9/2009
 WO 2009115631 A1 9/2009
 WO 2010125052 A2 11/2010

OTHER PUBLICATIONS

Jung, Sun-Mi et al., Abstract, Accession No. 7245617, Implementation of the Agent Based Digital Rights Management System for Interaction on the Web, published in Proceedings of the IASTED International Conference Internet and Multimedia Systems, conference article from conference held Aug. 13-16, 2008 in Honolulu, HI, USA.
 Arnab, Alapan et al., Verifiable Digital Object Identity System, pp. 19-25, published in DRM '06, Oct. 30, 2006, by the Association for Computing Machinery (ACM), in Alexandria, VA, USA.
 Paskin, N., Abstract, Accession No. 6191148, Title: The Digital Object Identifier System: Digital Technology Meets Content Management, Interlanding and Document Supply, 1999, vol. 27, Issue 1, pp. 13-16.
 Liu, Qiong et al., "Digital Rights Management for Content Distribution, School of Informatics Technology and Computer Science", Australasian Information Security Workshop 2003, in Adelaide, Australia, in 2003.
 Delgado, Jaime et al., Standardisation of the Management of Intellectual Property Rights in Multimedia Content, IEEE Proceedings of the Second International Conference on WEB Delivering of Music, Jan. 2002.
 Gil, Rosa et al., "Managing Intellectual Property Rights in the WWW: Patterns and Semantics", 2005, IEEE Proceedings of the First International Conference on Automated Production of Cross Media Content for Multi-Channel Distribution, 2005.
 M2 Presswire, IOMEGA: Iomega and Reciprocal Announce Strategic Relationship to Advance Secure Distribution of Portable Content: Partnership Enables Consumers to Transfer and Blind Secure Downloaded Content to Portable Zip Disks and Other Iomega Products, Jun. 27, 2001.

(56)

References Cited

OTHER PUBLICATIONS

Hwang, Seong-Oun et al., "Modeling and Implementation of Digital Rights", *The Journal Systems and Software*, 2004, vol. 73, pp. 533-549, 2004.

Williams, L.M., "E-warehouse is secure ESD (electronic software distribution)," *Tape-Disc Business* [Online], Aug. 1997, vol. 11, No. 8, p. 31 (5).

Radding, A., "Update reqs challenge software distribution tools," *Software Magazine* [Online], Sep. 1993, vol. 13, No. 14 (Special), pp. 31-41.

Digital Trends, "Philips Wants to Patent Must-See Ads," Apr. 19, 2006, available at <http://www.digitaltrends.com/home-theater/philips-wants-to-patent-must-see-ads/>.

Transmittal of the International Search Report and the Written Opinion of the International Searching Authority for International Application No. PCT/EP2007/005049, European Patent Office, Dec. 17, 2007.

Transmittal of the International Search Report and the Written Opinion of the International Searching Authority for International Application No. PCT/EP2007/008195, European Patent Office, Dec. 28, 2007.

Transmittal of the International Search Report and the Written Opinion of the International Searching Authority for International Application No. PCT/EP2010/055608, European Patent Office, Nov. 4, 2010.

Transmittal of the International Preliminary Report on Patentability and the Written Opinion of the International Searching Authority for International Application No. PCT/EP2008/009616, European Patent Office, May 25, 2010.

Spanish Patent and Trademark Office, International Preliminary Report on Patentability for International Application No. PCT/ES2009/070064, mailed Jul. 14, 2009. (Spanish Version).

Spanish Patent and Trademark Office, International Preliminary Report on Patentability for International Application No. PCT/ES2009/070064, mailed Oct. 20, 2010. (English Translation).

* cited by examiner

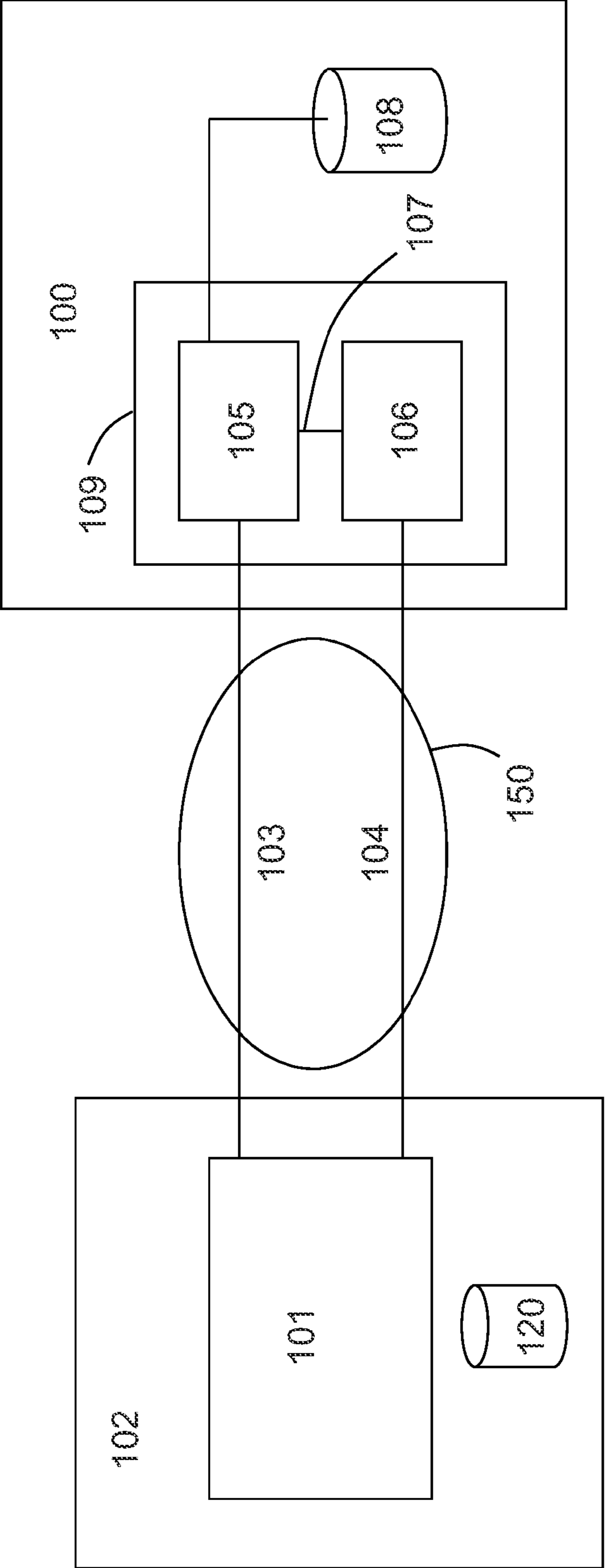

FIG. 1A

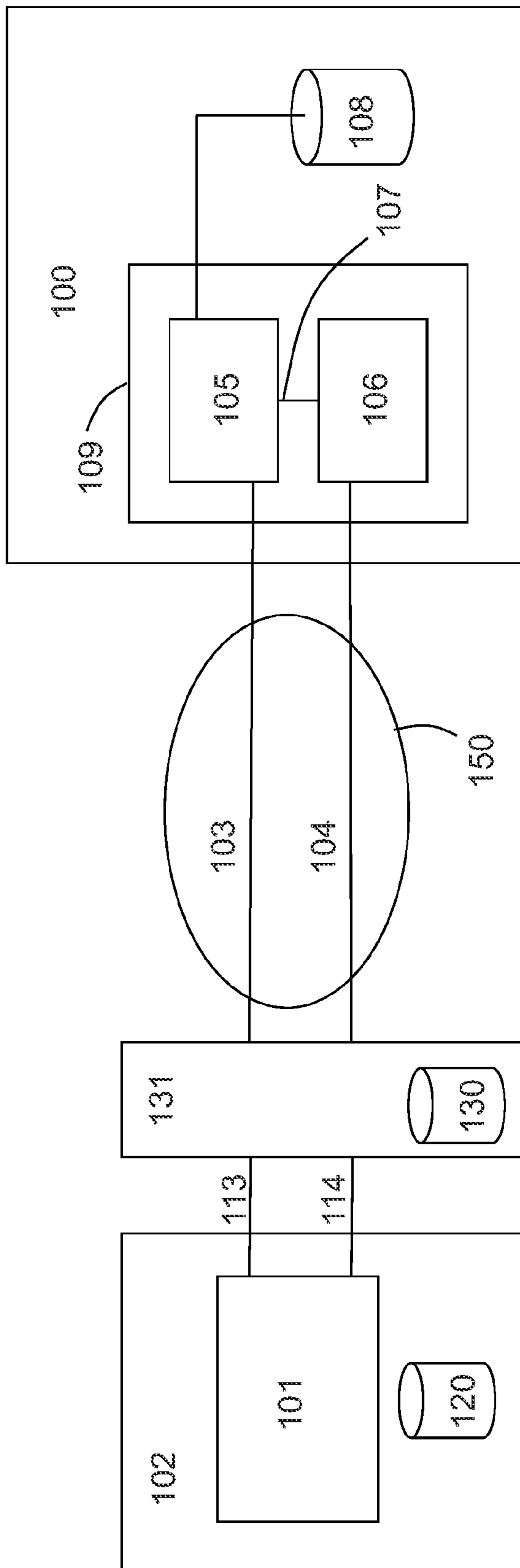

FIG. 1B

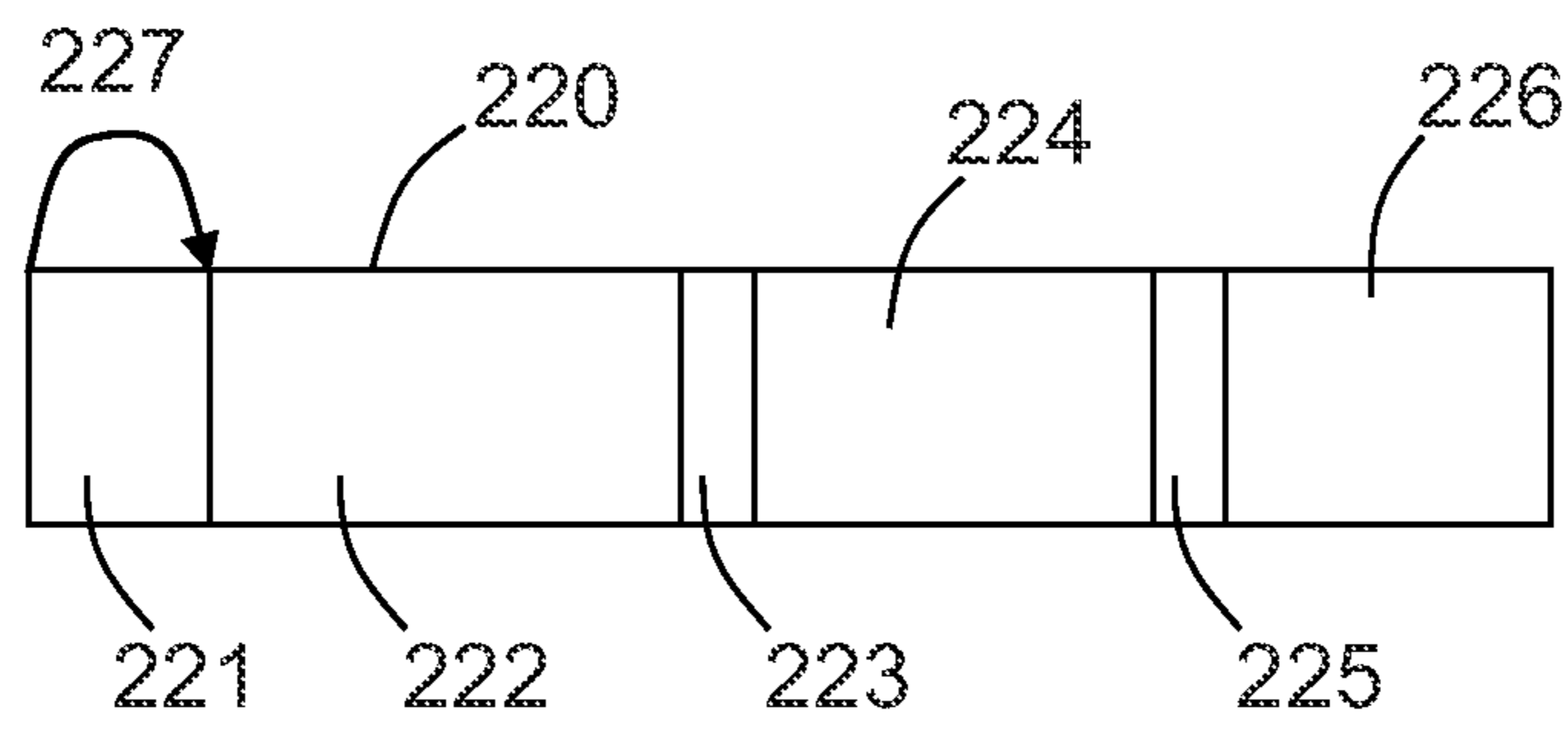
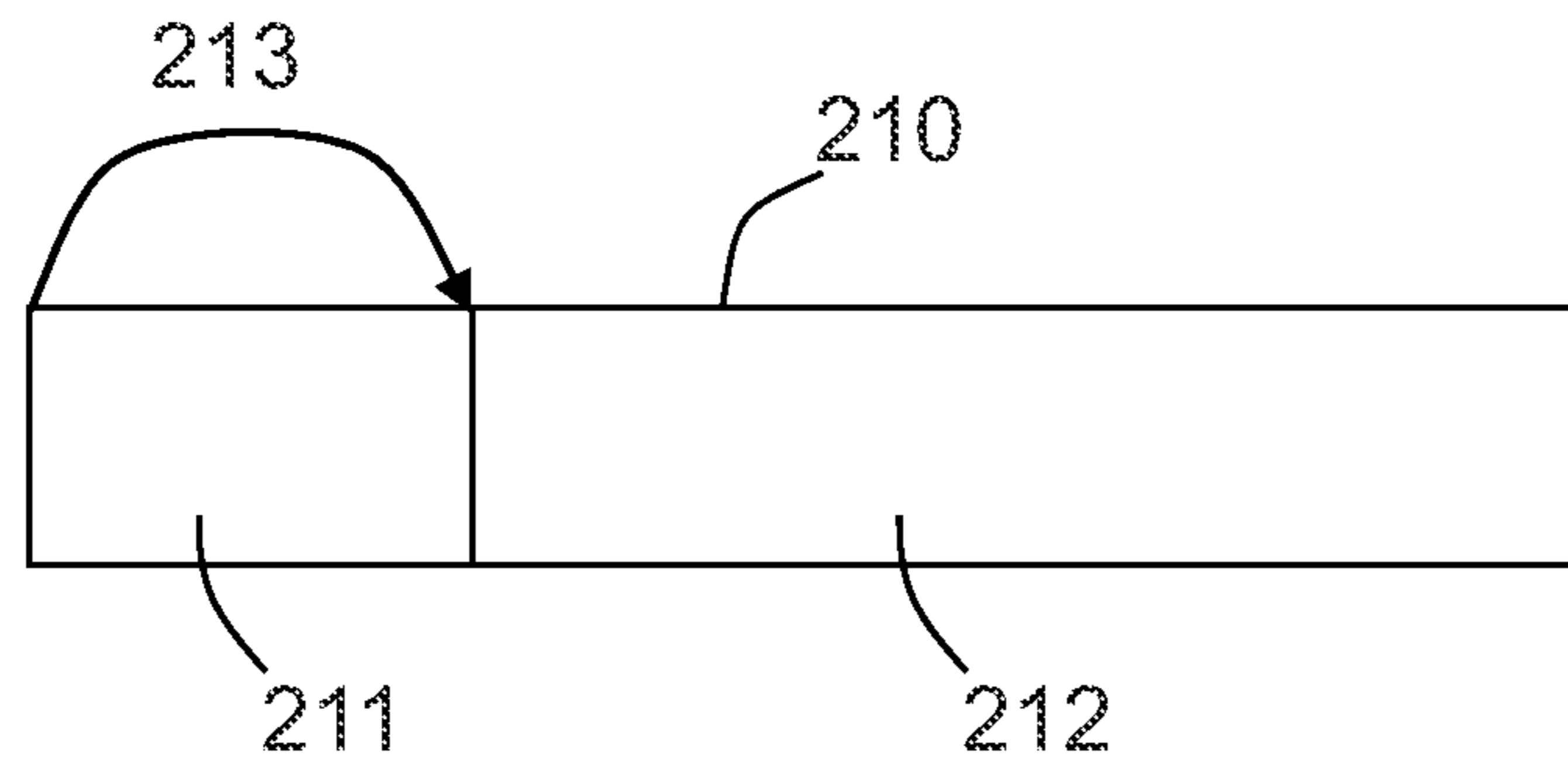

FIG. 2

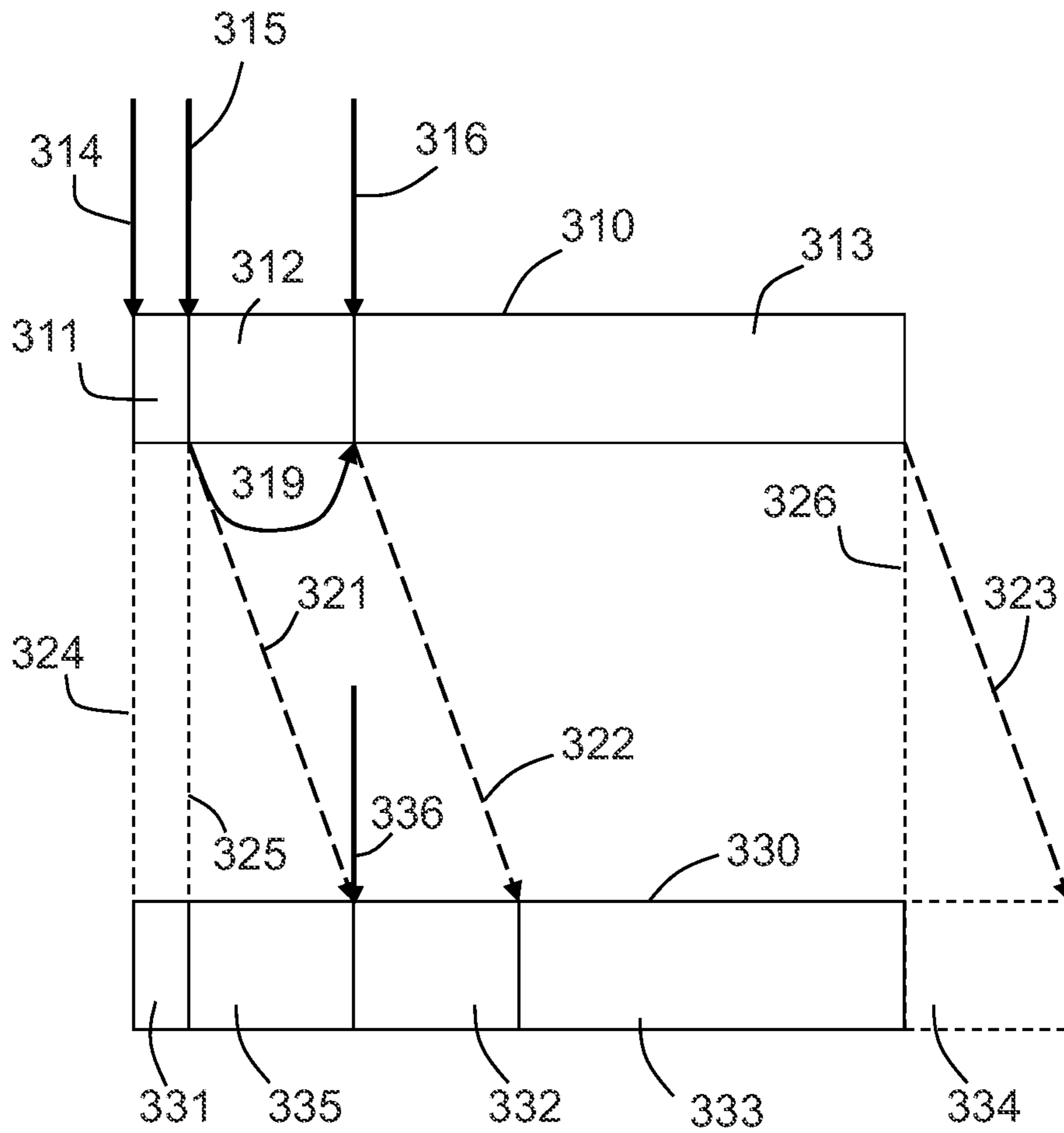

FIG. 3

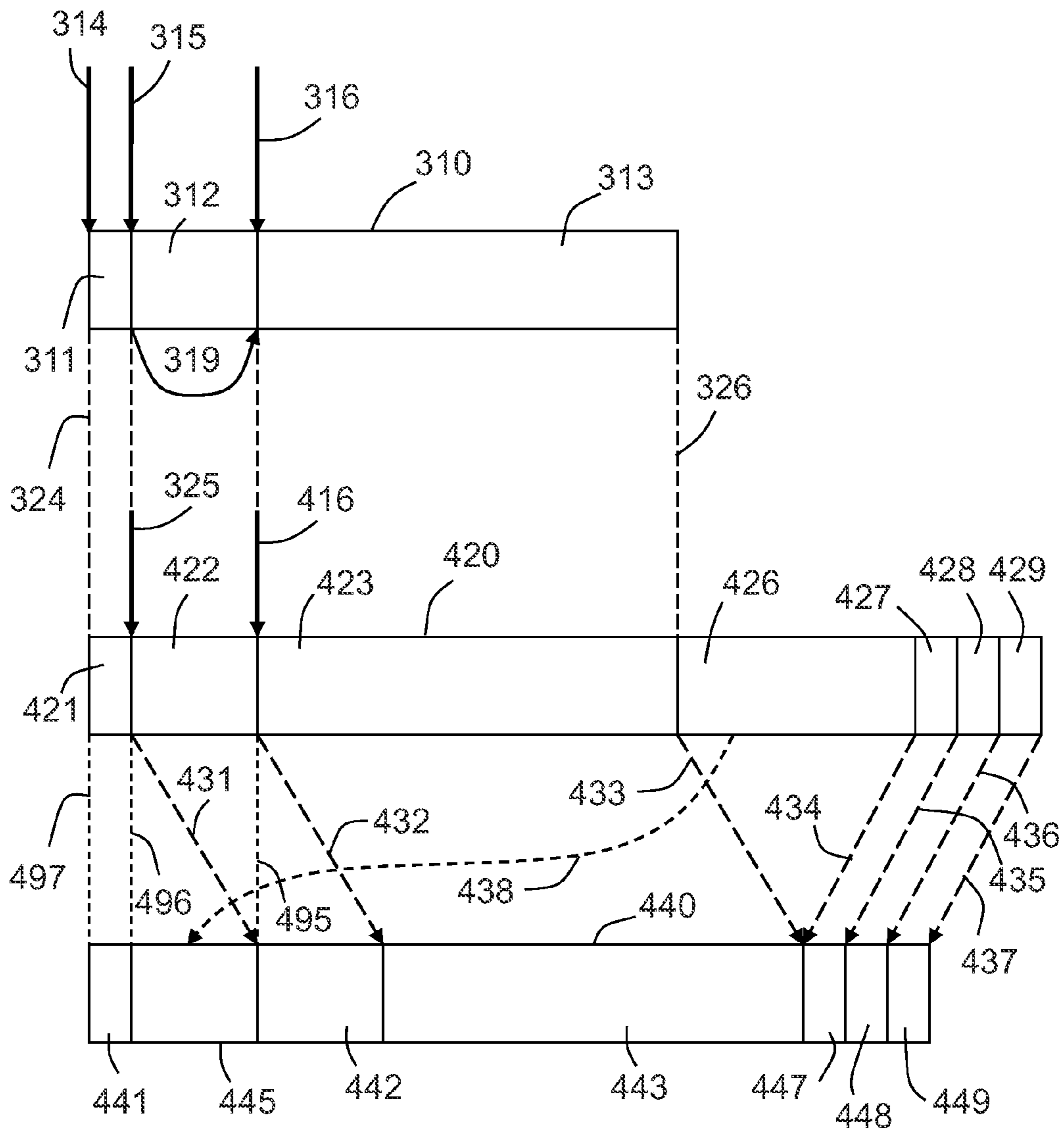

FIG. 4

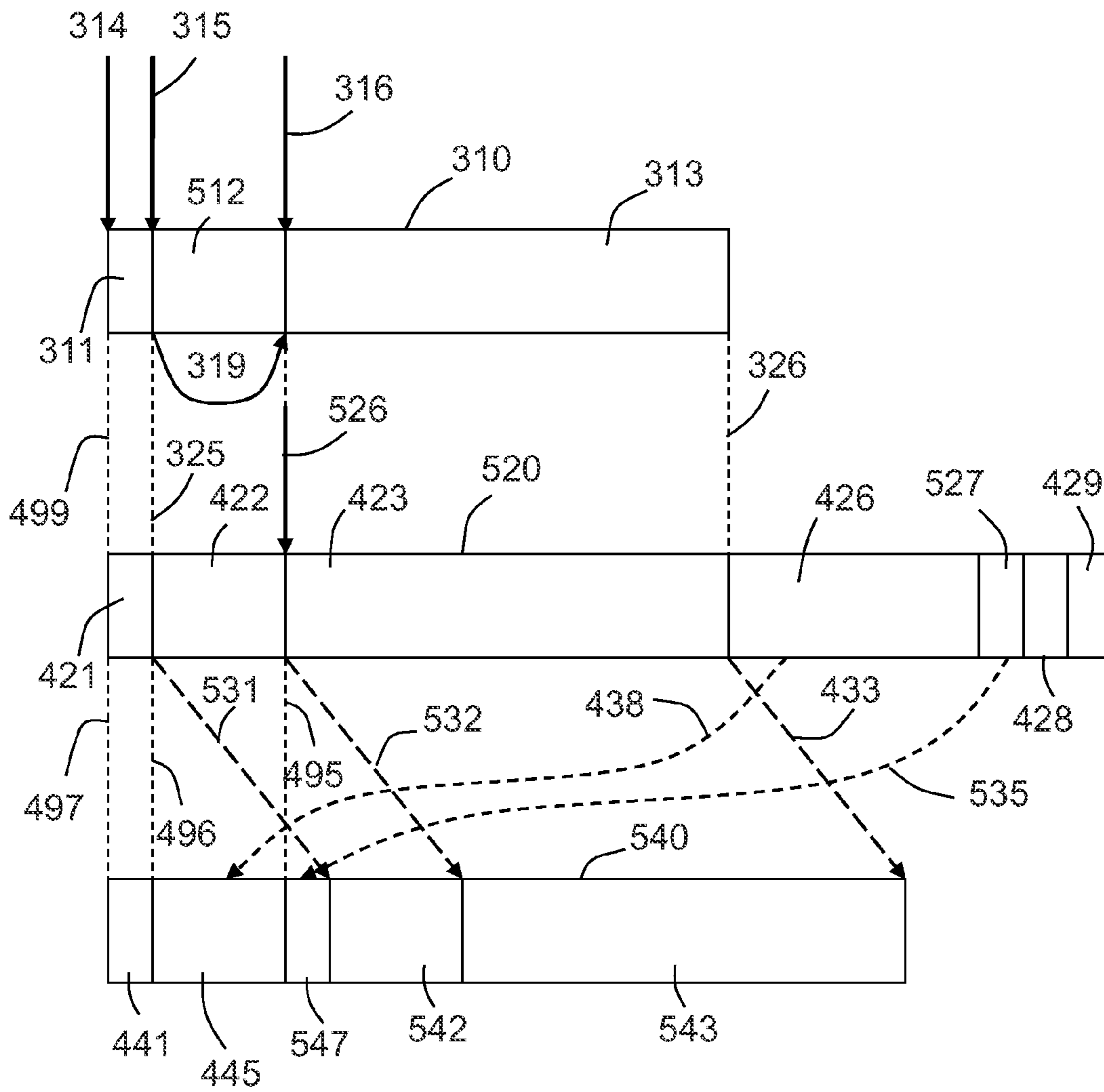

FIG. 5

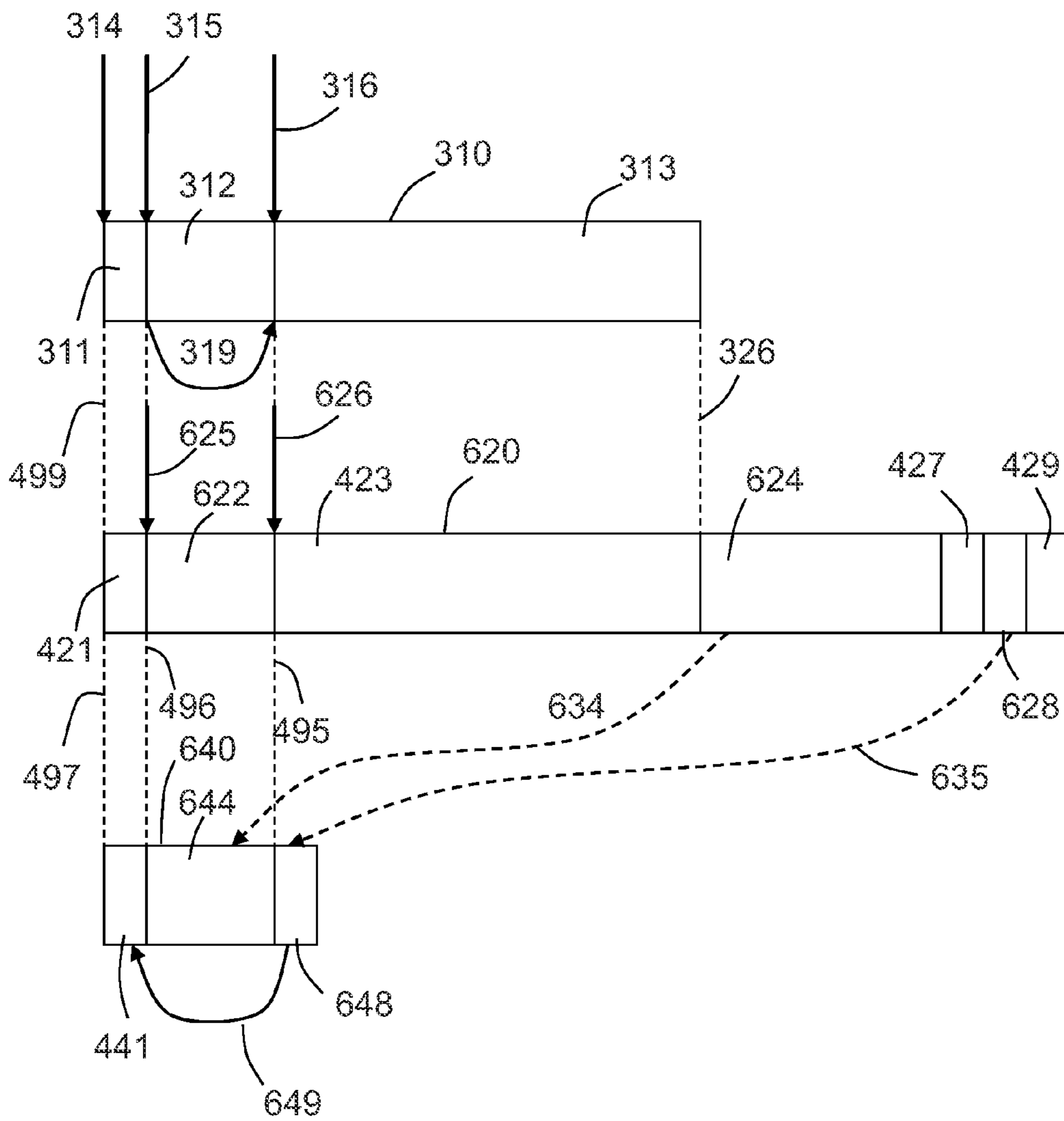

FIG. 6

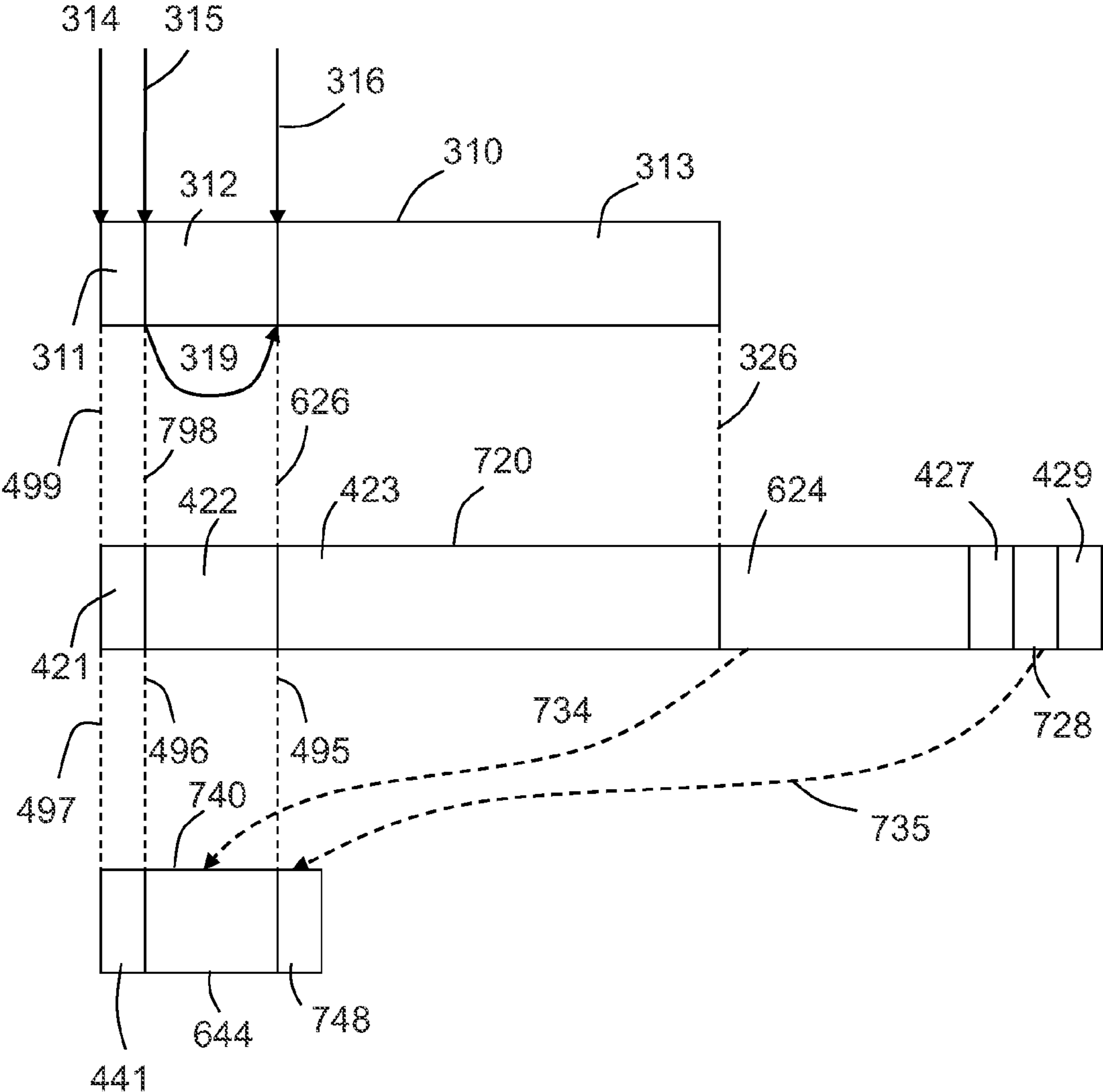

FIG. 7

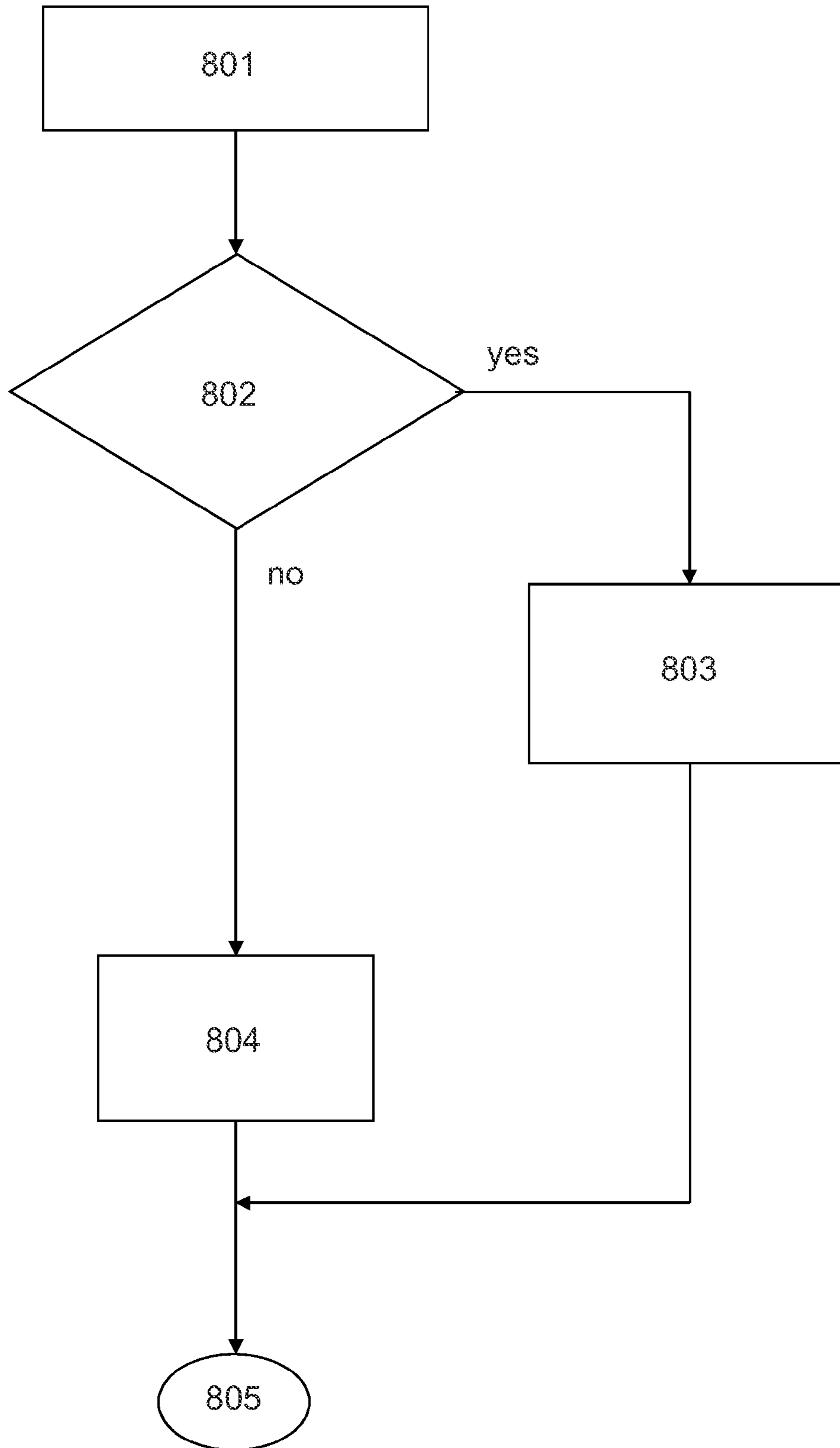

FIG. 8

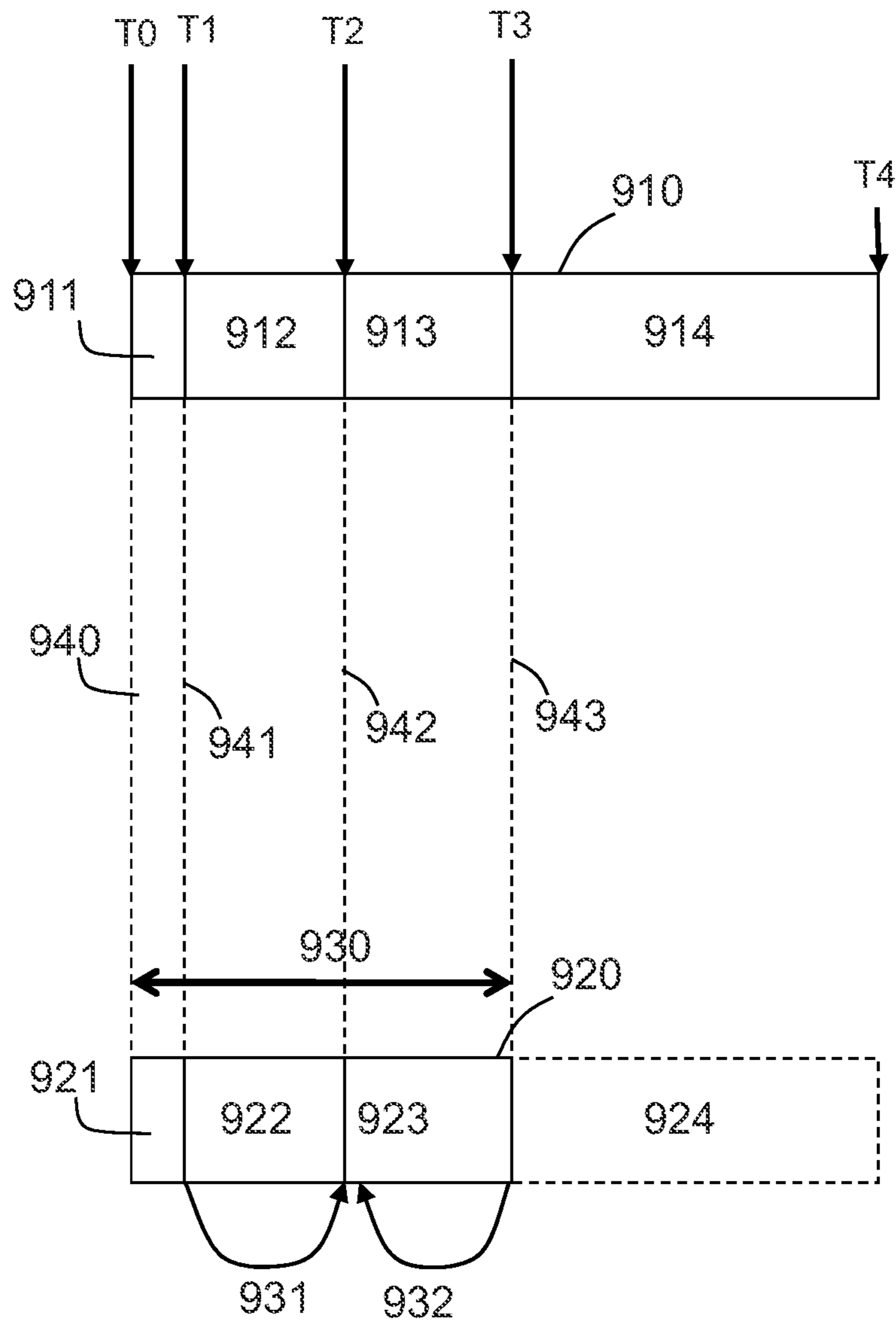

FIG. 9

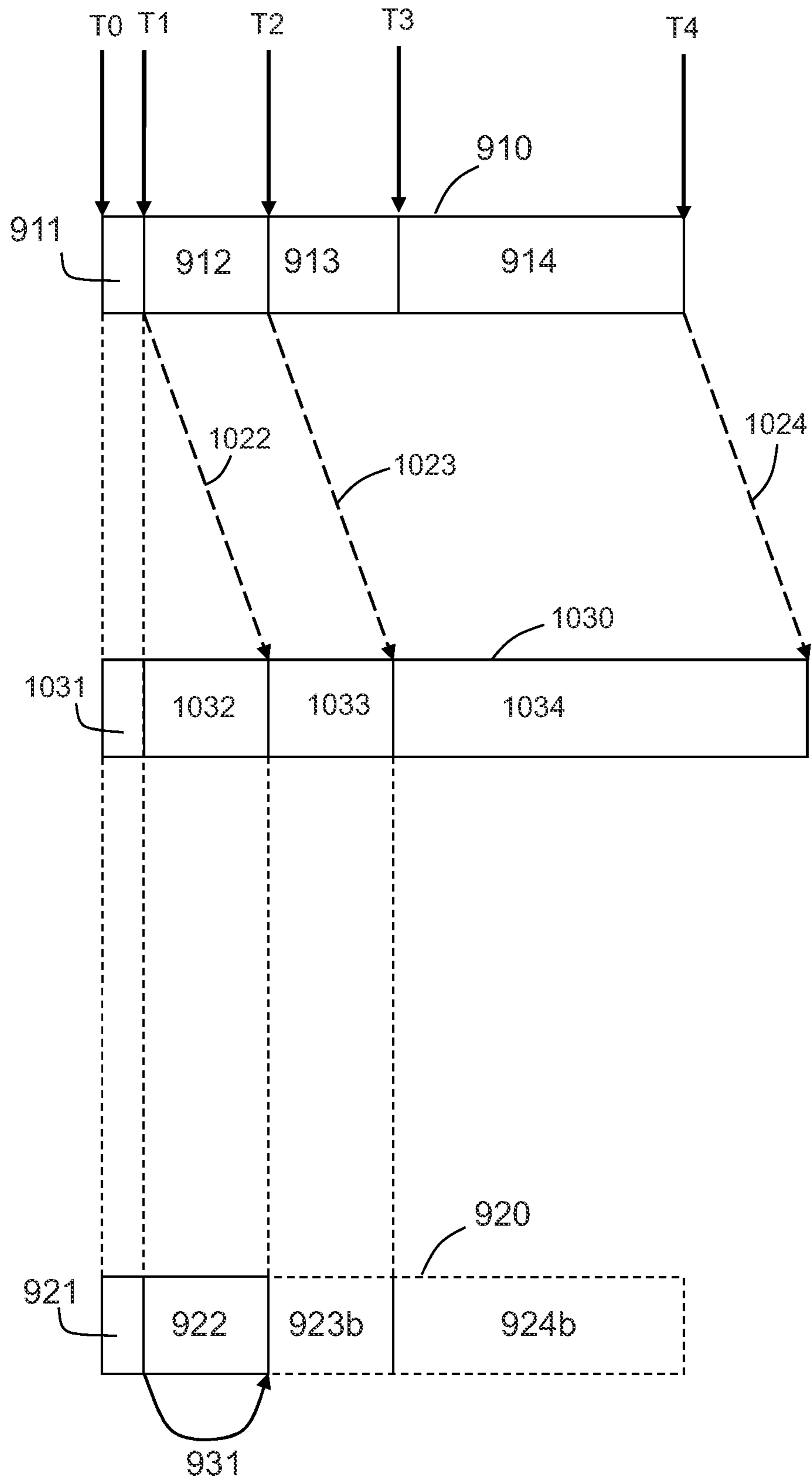

FIG. 10

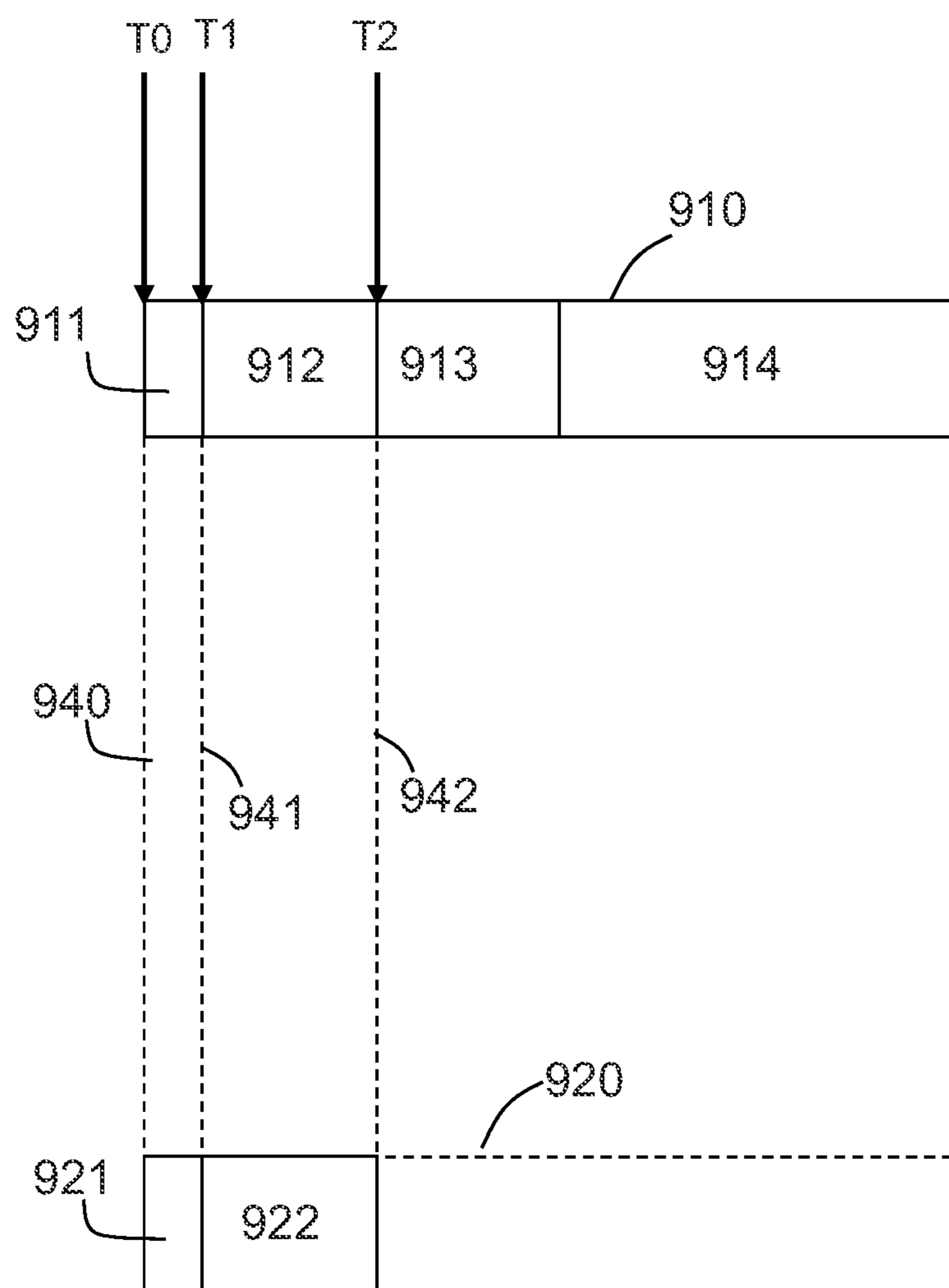

FIG. 11

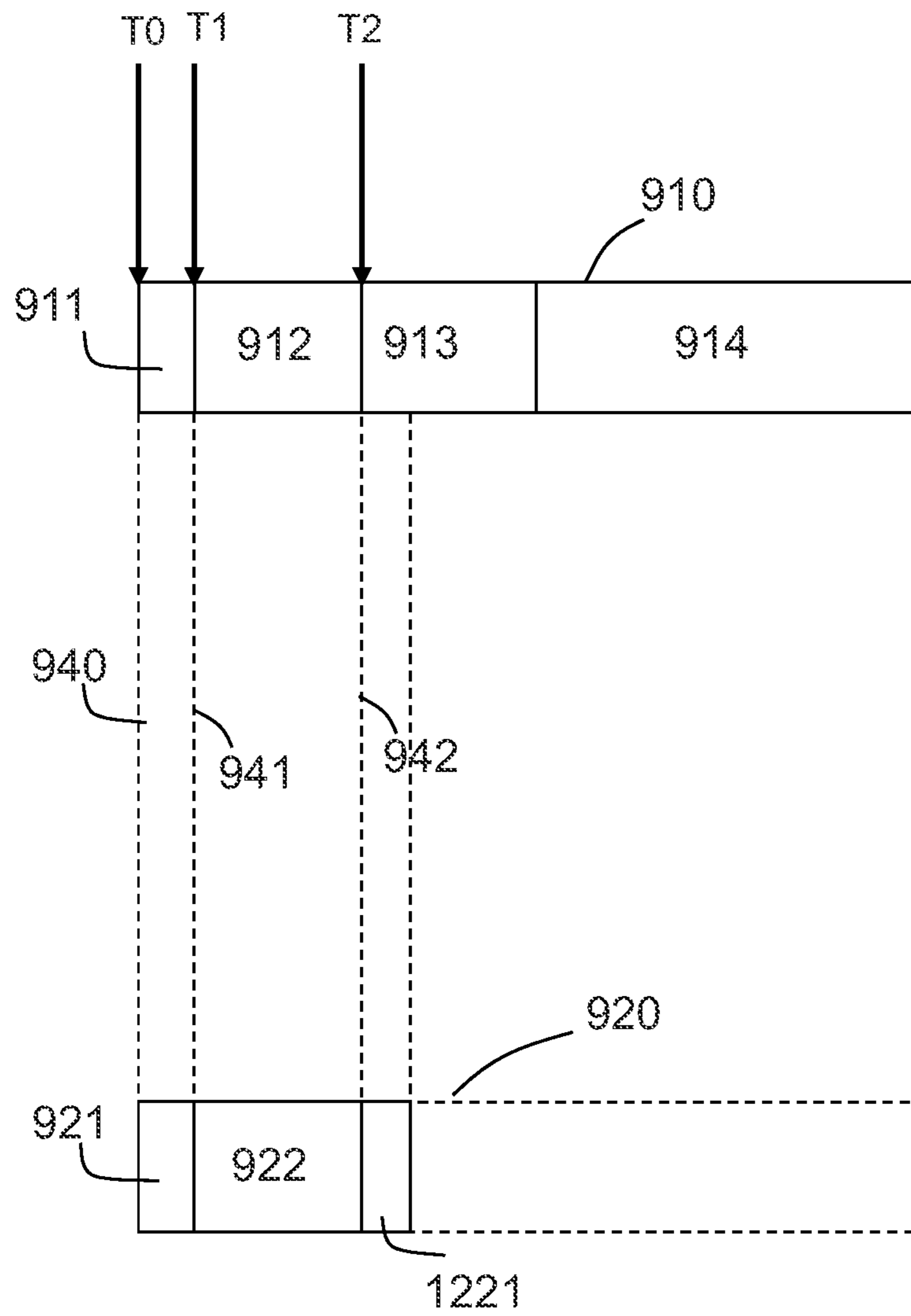

FIG. 12

METHODS FOR TRANSMITTING MULTIMEDIA FILES AND ADVERTISEMENTS

CROSS-REFERENCE TO RELATED APPLICATIONS

The present application is a continuation of U.S. patent application Ser. No. 13/157,175, filed Jun. 9, 2011 (now U.S. Pat. No. 8,090,774, issued Jan. 3, 2012), which is a continuation of U.S. patent application Ser. No. 12/702,168, filed Feb. 8, 2010 (now U.S. Pat. No. 7,984,097, issued Jul. 19, 2011), which is a continuation-in-part of U.S. patent application Ser. No. 12/431,553, filed Apr. 28, 2009 (now U.S. Pat. No. 8,185,625, issued Mar. 22, 2012), which claims priority to and the benefit of U.S. patent application Ser. No. 12/203,142, filed Sep. 2, 2008 (now U.S. Pat. No. 7,565,429 B1, issued Jul. 21, 2009), which claims priority to and the benefit of Spanish Patent Application No. 200800783, which is entitled "METHOD USED BY A STREAMING SERVER FOR TRANSMITTING A MULTIMEDIA FILE ON A DATA NETWORK," and was filed on Mar. 18, 2008, the disclosure of which is herein incorporated by reference.

TECHNICAL FIELD

The invention relates generally to methods for distributing digital files over a data network, in which the digital files contain an advertisement portion and a non-advertisement portion positioned after the advertisement portion, and the digital file may be not be viewed non-sequentially.

BACKGROUND

Known systems and methods for playing audiovisual content protected by intellectual property rights, such as movies or music, employ Digital Rights Management (DRM) technologies in which users pay to view the audiovisual content which they wish to view without also receiving advertising content.

Content producers and distributors who use this pay for content principle have been damaged by the creation of the Peer-to-Peer ("P2P") networks which allow users to exchange files free of charge. There currently are several P2P networks, such as eMule, Ares Galaxy, and Bittorrent, which are widespread. The P2P transmissions are systems that take advantage of the upload bandwidth which every user has in order to allow users to share files. As a result of this upload bandwidth, every user who receives data from a file may send the data to other users. In this way, a network of users is created who may exchange among themselves the data that comprise the file, instead of each user downloading the file in its entirety from a provider site.

The owners of the intellectual property rights of the files that are distributed on P2P networks have taken numerous legal actions in different countries with the intent of trying to close down the P2P networks. Nevertheless, in many countries, the current legal situation of the P2P networks is not very clear and varies from country to country. Moreover, "pure" P2P networks have appeared in which there are no servers that may be closed down. These new networks use new technologies, such as Distributed Hash Tables (DHT) that allow the networks to operate without any server. Thus, there is no single central point for closing down the operation of the network. To close down a pure P2P network, a substantial portion of its nodes must be frozen, which makes it difficult to effectively close down these networks.

Despite increasing popularity of P2P networks and increasing complexity of DRM technologies, there has not been a significant effect on conventional television that applies advertising systems.

Another known system and method for playing videos uses streaming technology, which allows a user to begin to view the content while downloading it, without needing to wait for the file to be completely downloaded. These known systems may use a streaming protocol, e.g., the Real Time Streaming Protocol ("RTSP"), which is described in the RFC 2326 specifications published by the IETF (Request for Comments 2326, April 1998; currently available at the Internet address <http://www.ietf.org/rfc/rfc2326.txt>), the entirety of which is herein incorporated by reference. The operation of the RTSP protocol may be closely related to two other IETF (Internet Engineering Task Force) protocols, the SDP and RTP protocols.

The Session Description Protocol (SDP) is described in the RFC 4566 specifications published online by the IETF. (M. Handley et al., Request For Comments 4566, Network Working Group, July 2006, currently available at the Internet address <http://www.ietf.org/rfc/rfc4566.txt>), the entirety of which is herein incorporated by reference. The Real-Time Transport Protocol (RTP) is described in the RFC 3550 specifications published online by the IETF. (H. Schulzrinne et al., Request For Comments 3550, Network Working Group, July 2003, currently available at the Internet address <http://www.ietf.org/rfc/rfc3550.txt>), the entirety of which is herein incorporated by reference.

A newer draft of the RTSP protocol, designated as RTSP 2.0, is described in the document published online by the IETF "Real Time Streaming Protocol 2.0 (RTSP) draft-ietf-mmusic-rfc2326bis-16.txt", H. Schulzrinne et al., MMUSIC Working Group, Nov. 19, 2007, currently available at the Internet address <http://www.ietf.org/internet-drafts/draft-ietf-mmusic-rfc2326bis-16.txt>), the entirety of which is herein incorporated by reference.

Another protocol related to the RTSP is the HTTP protocol (Hypertext Transfer Protocol) described in the RFC 2616 specifications published online by the IETF (R. Fielding et al., Request For Comments 2616, Network Working Group, June 1999, currently available at the Internet address <http://www.w3.org/Protocols/rfc2616/rfc2616.html>), the entirety of which is herein incorporated by reference.

The RTSP is a client-server protocol based on text messages designed to facilitate communication between a client and a streaming server, such that the client controls the streaming transmission from the server using the RTSP protocol as though it were a remote control of the server. The client may be any equipment configured to play a multimedia stream, such as a computer, a PDA, a mobile phone and in general any equipment that incorporates an audio or video player.

RTSP allows one or more flows of data, e.g., "streams," to be established from the streaming server to the multimedia player. The RTSP protocol is the protocol that the multimedia player uses to communicate to the streaming server the content it wishes to receive by RTSP messages. The streaming server also sends RTSP messages to the multimedia player with information about the selected content and the way in which it is going to transmit it to the multimedia player.

The RTSP protocol uses the term "presentation" to refer to a set of streams that are presented together to the customer and that are defined in a presentation file called "Presentation Description" or "Presentation Description File." Other pro-

ocols use different names to refer to a presentation. For example, the SDP protocol uses the term “session” to refer to a presentation.

The presentation file contains information about each stream that includes, for example, information on whether it is an audio or video stream, the type of coding used, Internet addresses needed to access each stream, or the like.

The presentation file may use various formats to describe this information. The SDP protocol is usually the most used, although it is not necessary to use the SDP protocol, and the RTSP protocol may describe the information using protocols other than the SDP. A file of a presentation is normally identified by a URI (“Uniform Resource Identifier”). For example, the next URI could be used to identify the file of a presentation:

rtsp://media.example.com:554/twister/audiotrack

The client may access the file of a presentation using the RTSP protocol or other protocols, such as the HTTP (Hypertext Transfer Protocol) protocol. The client may also receive the file that describes the presentation by electronic mail or by any other means.

RTSP uses the term “container file” to refer to a multimedia file that contains the data of one or more streams and which normally form a presentation when they are played together. For example, a container file may contain three streams: a first video stream of a movie, a second stream for the audio of the movie in English and a third stream with the audio in Spanish.

RTSP uses the term “RTSP session” to define an abstraction (for example a software module being run on the streaming server) that uses the streaming server to control each presentation it sends to each user. Each RTSP session is created, maintained and eliminated by the server. Normally a client requests to create a session by sending the SETUP command from the RTSP protocol to the server and receives an RTSP response from the server, called RESPONSE message with an identifier of the session created.

The RTSP sessions maintain information on the status of each presentation requested by each user. This is an important difference with respect to the HTTP protocol, which is a protocol that does not maintain the status of the client’s requests.

Another important difference is that in the RTSP protocol, the server may send RTSP messages with commands to the client as well as receive them. The following table 1 taken from the RFC 2326 indicates the different commands, messages or methods in RTSP terminology, which may be sent between the client and the server. The RTSP server may send packets of data from each stream to the client using the RTP protocol, but RTSP does not depend on the RTP protocol and could use other carrier protocols.

TABLE 1

| method | direction | object | requirement |
|---------------|------------|--------|------------------------------|
| DESCRIBE | C->S | P, S | recommended |
| ANNOUNCE | C->S, S->C | P, S | optional |
| GET_PARAMETER | C->S, S->C | P, S | optional |
| OPTIONS | C->S, S->C | P, S | required (S->C: optional) |
| PAUSE | C->S | P, S | recommended |
| PLAY | C->S | P, S | required |
| RECORD | C->S | P, S | optional |
| REDIRECT | S->C | P, S | optional |
| SETUP | C->S | S | required |
| SET_PARAMETER | C->S, S->C | P, S | optional |
| TEARDOWN | C->S | P, S | required |

In these known systems which use streaming protocols, a distributor may transmit a digital file to a user, and the user may view the digital file. The digital file may comprise a first portion which comprises advertising content, and a second portion which contains content which the user requested to view. The advertising content is presented to the user before the user requested content is presented to the user. Nevertheless, the streaming protocols allow the user to non-sequentially view the content of the digital file, such that the user is able to skip the advertisement, or fast forward through the advertising content, to reach the user requested content. Consequently, these known systems may not be effective with respect to achieving the goal of having the user view the advertising content.

SUMMARY OF THE DISCLOSURE

Therefore, a need has arisen for methods for providing an improved system for transmitting content, including advertising, over a data network, such as the Internet.

An embodiment of the invention comprises a method of transmitting a digital file comprising an advertising portion comprising a first type of content and a requested portion comprising a second type of content which is different than the first type of content, the method comprising the steps of receiving, via a streaming protocol, a request to transmit the digital file, wherein the streaming protocol is configured to allow non-sequential access to the digital file, transmitting the advertising portion of the digital file in response to the request to transmit the digital file, receiving, via the streaming protocol, a request to transmit at least one portion of the requested portion of the digital file after beginning transmission of the advertising portion and prior to completion of the transmission of the advertising portion of the digital file, transmitting a signal comprising an indication that the signal will be followed by the at least one portion of the requested portion prior to completing the transmission of the advertising portion, completing the transmission of the advertising portion of the digital file after receiving the request to transmit the requested portion of the digital file, and, after completing the transmission of the advertising portion, transmitting the at least one portion of the requested portion of the digital file.

Another implementation comprises a method of transmitting digital data comprising an advertising portion comprising a first type of content and a requested portion comprising a second type of content which is different than the first type of content, the method comprising the steps of receiving a first request to transmit the digital data, generating a first digital file comprising the digital data and supplemental digital data, transmitting the advertising portion of the digital data in response to the first request, receiving a second request to transmit at least one portion of the requested portion of the digital data after beginning transmission of the advertising portion of the digital data and prior to completion of the transmission of the advertising portion of the digital data, such that a first portion of the advertising portion is transmitted prior to receiving the second request, and a second portion of the advertising portion is untransmitted prior to receiving the second request, generating a second digital file by positioning a portion of the supplemental digital data between the first portion of the advertising portion and the second portion of the advertising portion, completing the transmission of the advertising portion of the digital data after receiving the second request, and, after completing the transmission of the advertising portion of the digital data, transmitting the at least one portion of the requested portion of the digital data.

5

Still another implementation comprises a method of transmitting digital data comprising an advertising portion comprising a first type of content and a requested portion comprising a second type of content which is different than the first type of content, the method comprising the steps of receiving a first request to transmit the digital data, generating a particular digital file comprising the digital data and supplemental digital data, transmitting the advertising portion of the digital data in response to the first request, receiving a second request to transmit at least one portion of the requested portion of the digital data after beginning transmission of the advertising portion of the digital data and prior to completion of the transmission of the advertising portion of the digital data, and terminating the transmission of the advertising portion of the digital data.

In one implementation a method is provided that comprises transmitting in a streaming session from a server first streaming data to a data storage medium of a device having a multimedia player, the first streaming data comprising a first advertising-sponsored content portion and an associated first obligatory advertising portion, the first streaming data having a play sequence with the first obligatory advertising portion designated to precede the first advertising-sponsored content portion, upon the server detecting that the playing of all or part of the first obligatory advertising portion is attempting to be avoided by the multimedia player, the server sends to the device a message with data storage medium control information for the purpose of inhibiting the first advertising-sponsored content portion stored in the data storage medium from being played by the multimedia player.

In one implementation a method is provided that comprises transmitting in a streaming session from a server first streaming data to a data storage medium of a device having a multimedia player, the first streaming data comprising a first advertising-sponsored content portion and an associated first obligatory advertising portion, the first streaming data having a play sequence with the first obligatory advertising portion designated to precede the first advertising-sponsored content portion when played by the multimedia player, the first obligatory advertising portion having a start time T1 and the first advertising-sponsored content portion having a start time T2, start time T1 and start time T2 each having an association with a normal play time of the obligatory advertising portion and advertising-sponsored content portion, respectively, when played by the multimedia player, the server maintaining a time variable that changes in response to multimedia player navigation messages received in the server so that the time variable maintains a known relationship with start time T1 and start time T2, the server maintaining a record derived from the time variable that comprises a value associated with the most advanced normal play time moment of the first streaming data by the multimedia player during the streaming session.

In one implementation a method is provided that comprises transmitting from a first server first streaming data to a data storage medium of a device having a multimedia player, the first streaming data comprising an advertising-sponsored content portion, transmitting from a second server second streaming data to the data storage medium, the second streaming data comprising an obligatory advertising portion associated with the advertising-sponsored content portion, the first server and/or second server communicating with the device using a communications protocol that enables the first server and/or the second server to regulate, at least in part, the accessibility of at least part of the data storage medium by the multimedia player; and upon detecting in the first server or the second server that the playing of all or part of the obligatory

6

advertising portion is attempting to be avoided by the multimedia player, the first server or second server inhibits the advertising-sponsored content portion stored in the local memory from being played by the multimedia player.

In one implementation a method is provided that comprises transmitting streaming data to a data storage medium of a device having a multimedia player, the streaming data comprising an advertising-sponsored content portion and an associated obligatory advertising portion, the obligatory advertising portion being first transmitted to the data storage medium; and upon determining that the obligatory advertising portion has been played in the multimedia player, transmitting the advertising-sponsored content portion to the data storage medium.

In one implementation a method is provided that comprises transmitting streaming data to a data storage medium of a device having a multimedia player, the streaming data comprising an advertising-sponsored content portion and an associated obligatory advertising portion, the obligatory advertising portion being first transmitted to the data storage medium; and upon determining that the obligatory advertising portion has been played in the multimedia player, transmitting the advertising-sponsored content portion to the data storage medium upon receiving a play request from the multimedia player.

In one implementation a method is provided that comprises transmitting from a first server first streaming data to a data storage medium of a device having a multimedia player, the first streaming data comprising an obligatory advertising portion; and upon determining that the obligatory advertising portion has been played in the multimedia player, transmitting from a second server second streaming data comprising an advertising-sponsored content portion to the data storage medium upon the second server receiving a play request from the multimedia player.

In one implementation a method is provided that comprises transmitting streaming data to a data storage medium of a device having a multimedia player, the streaming data comprising an advertising-sponsored content portion and an associated obligatory advertising portion, the obligatory advertising portion being transmitted to the data storage medium at a first transmission rate and the advertising-sponsored content portion being transmitted to the data storage medium at a second transmission rate slower than the first transmission rate at least prior to all, or substantially all, of the obligatory advertising portion is played by the multimedia player.

BRIEF DESCRIPTION OF THE DRAWINGS

For a more complete understanding of the present invention, the needs satisfied thereby, and the objects, features, and advantages thereof, reference now is made to the following descriptions taken in connection with the accompanying drawings.

FIG. 1A is a block diagram illustrating a system for carrying out distribution of files from a streaming server to communication equipment, e.g., a multimedia player, according to an embodiment of the invention.

FIG. 1B is a block diagram illustrating another system for carrying out distribution of files from a streaming server to communication equipment, e.g., a multimedia player, according to an embodiment of the invention.

FIG. 2 is a block diagram illustrating multimedia files having portions containing content and portions containing advertising, according to an embodiment of the invention.

FIG. 3 is a diagram containing a multimedia file and a virtual file, and illustrating the process of transmitting the

multimedia file when there is a request to retrieve non-sequential content from the file, according to a known process.

FIG. 4 is a diagram containing a multimedia file and two virtual files, and illustrating the process of transmitting the multimedia file when there is a request to retrieve non-sequential content from the file, according to an embodiment of the invention.

FIG. 5 is a diagram containing a multimedia file and two virtual files, and illustrating the process of transmitting the multimedia file when there is a request to retrieve non-sequential content from the file, according to another embodiment of the invention.

FIG. 6 is a diagram containing a multimedia file and two virtual files, and illustrating the process of transmitting the multimedia file when there is a request to retrieve non-sequential content from the file, according to still another embodiment of the invention.

FIG. 7 is a diagram containing a multimedia file and two virtual files, and illustrating the process of transmitting the multimedia file when there is a request to retrieve non-sequential content from the file, according to yet another embodiment of the invention.

FIG. 8 is a flowchart illustrating a verification carried out according to an embodiment of the invention.

FIG. 9 is a diagram illustrating a method of transmitting streaming data to a data storage medium accessible to a multimedia player in one implementation.

FIG. 10 is a diagram illustrating a method of transmitting streaming data to a data storage medium accessible to a multimedia player in another implementation.

FIG. 11 is a diagram illustrating a method of transmitting streaming data to a data storage medium accessible to a multimedia player in another implementation.

FIG. 12 is a diagram illustrating a method of transmitting streaming data to a data storage medium accessible to a multimedia player in another implementation.

DETAILED DESCRIPTION

Embodiments of the present invention and their advantages may be understood by referring to FIGS. 1A-12, like numerals being used for like corresponding parts in the various drawings.

As shown in FIG. 1A, a device 102, e.g., a personal computer, a PDA, a mobile phone, or any other device configured to play or display any type of media, may comprise a media player, e.g., multimedia player 101. Device 102 may communicate with a server, e.g., a streaming server 100. Streaming server 100 may be a streaming server that uses the RTSP and RTP protocols or any other protocols useful in transmitting streaming data. Device 102 may be a personal computer, a PDA, a mobile phone or any other device that may comprise a multimedia player 101. In one implementation, the multimedia player 101 has access to a local memory 120, such as a cache memory, that is located within, or otherwise coupled to device 102.

Streaming server 100 may comprise an RTSP module 105 and an RTP module 106, or any other suitable module or modules, which may be used by an application 109 to facilitate the transmission of information between streaming server 100 and device 102. Application 109 may perform streaming functions in server 100. RTSP module 105 and RTP module 106 may control RTSP and RTP communications, respectively, with the multimedia player 101. RTSP module 105 and RTP module 106 may operate in a coordinated manner in the streaming server, and may communicate between themselves via a communication path, e.g., line 107.

The streaming server 100 also may comprise a database or storage means 108 which may store files, e.g., multimedia files, audio files, video files, and the like. The streaming server 100 may combine various multimedia files in order to generate new multimedia files. Specifically, streaming server 100 may combine advertising files with content files in order to generate a multimedia file that contains advertising and content. A user of multimedia player 101 may request a specific file or a file of a specific content, which streaming server 100 may retrieve from storage means 108.

As shown in FIG. 1A, RTSP communication between multimedia player 101 and module 105 of streaming server 100 may be carried out via a communication path, e.g., line 103. This communication may comprise the multimedia player 101 and the streaming server 100 exchanging messages in the RTSP protocol.

RTP communication, or the like, may be carried out via a communication path, e.g., line 104 and may be used, such that the streaming server 100 sends RTP packets to the multimedia player 101 and also, such that the streaming server 100 and the multimedia player 101 may exchange some control packets using, for example, a Real-Time Control Protocol, ("RTCP"), which may be a part of the RTP protocol. Communications represented by lines 103 and 104 may be a portion of a data network 150, e.g., the Internet, a Local Area Network ("LAN"), a Wide Area Network ("WAN"), or the like.

It is important to note that the present invention is not limited to RTSP, RTCP or RTP, but may be implemented using any other single protocol or set of protocols that facilitate the various communication and data transport activities disclosed and contemplated herein. However, for ease of discussion, the RTSP, RTCP and RTP will be used throughout this disclosure to describe various implementations. Other implementations using other protocols and/or communication schemes also fall within the scope of the disclosure.

Turning again to FIG. 1A, the RTSP and RTP communications are depicted as being transported via different communication paths 103 and 104. Line 103 may represent RTSP communications and line 104 may represent RTP and RTCP communications. Nevertheless, in one implementation, both communications may function by use of a single communication path by, for example, sharing the same TCP/IP connection. In another implementation, the RTP protocol may use two different TCP/IP connections, e.g., a first connection for the RTP packets and a second connection for the RTCP packets. In yet other embodiments, more or fewer communication paths may be used.

FIG. 1B illustrates another system for carrying out distribution of files from a streaming server to communication equipment that includes a proxy device 131, for example a RTSP proxy, that receives information from the streaming server 100 and stores this information in a local memory 130 (e.g., cache memory), before transmitting all or a portion of the information to device 102. In the example of FIG. 1B, the proxy device 131 communicates with device 102 via communication paths 113 and 114. In one implementation, communication path 113 may be used for transmitting messages (e.g., RTSP messages) between device 102 and proxy device 131 and communication path 114 may be used for transporting data (e.g., RTP streaming data). In another implementation, device 102 and proxy device 131 use a single communication path or more than two communication paths to facilitate the transmission of information between the two devices.

Referring now to FIG. 2, a multimedia file 210 may comprise one or more streams, e.g., audio streams, video streams,

streams containing movies and songs or portions of movies and songs, and the like. Multimedia file **210** may comprise a first portion, e.g., advertising portion **211**, and a second portion, e.g., content portion **212**. The protocol may be designed, such that a user may send an instruction for multimedia player **101** to skip advertising portion **211**, represented in FIG. **2** by line **213**. Multimedia file **220** may comprise a plurality of, e.g., three, advertising portions, e.g., advertising portions **221**, **223** and **225**, and a plurality of, e.g., three, content portions, e.g., content portions **222**, **224** and **226**. Although FIG. **2** illustrates three advertising portions and three content portions, multimedia files which contain different numbers of advertising portions and content portions may be used. In FIG. **2**, a user of a multimedia player **101** may send an instruction for multimedia player **101** to skip the advertising as shown by line **227**.

FIG. **3** illustrates an operation that prevents the multimedia player **101** from skipping the advertising of a transmission of a multimedia file **310** transmitted by streaming server **100**, according to an embodiment of the invention. In order to simplify the explanation, FIG. **3** shows a file **310** that contains advertising portions **311** and **312** before a single content portion **313**. Nevertheless, fewer or more advertising portions, or content portions, or both, may be present. File **310** may be a multimedia file or “container file” stored in the database **108** of the streaming server **100**. Multimedia file **310** may contain various audio and video streams that may not be shown, in order to simplify the figure. Multimedia file **310** may have an order of transmission, such that advertising portions **311** and **312** may be transmitted prior to transmission of content portion **313**.

Streaming server **100** may receive, for example by the RTSP protocol, a message, e.g., a SETUP message, which may cause streaming server **100** to prepare a multimedia transmission. Upon receiving the message, streaming server **100** may create an RTSP session and may send a message, e.g., a RESPONSE message, to multimedia player **101**. The RESPONSE message may comprise the information needed for multimedia player **101** to send RTSP message using the RTSP session created by streaming server **100**. Streaming server **100** then may receive a message, e.g., a first PLAY message, to initiate the transmission of the content of file **310** from its beginning. This transmission may be indicated in FIG. **3** by arrow **314**.

Upon receiving the first PLAY message in the RTSP protocol, streaming server **100** may initiate a multimedia transmission of file **310** to multimedia player **101** using the RTP protocol, and may send the multimedia information in RTP packets through the RTP communication. When the streaming server **100** has transmitted a first portion of the file **310**, e.g., advertising portion **311**, the streaming server **100** may receive, by the RTSP protocol, a message, e.g., a second PLAY message, with a new play range that may requests that the streaming server **100** send the multimedia, such that the multimedia player **101** continues playing the multimedia file **330** starting from a specific point, e.g., the point indicated by arrow **316** in FIG. **3**.

By sending the request to continue playing starting from a specific point, multimedia player **101** may be indicating a request to skip advertising portion **312**, at a specific point, e.g., the point at arrow **315**, in order to begin viewing content portion **313**. A known streaming server may make the skip, represented by line **319**, and may begin to play content **313** without transmitting advertising **312**. However, the streaming server **100** described in an embodiment of the invention may perform an operation, e.g., a “virtual RTSP skip” and may continue transmitting information **312** from the multimedia

file. Streaming server **100** may send an RTSP response message of the type “RESPONSE, 200, OK” to multimedia player **101**, instructing it to process its play order starting from point **316**. Nevertheless, streaming server **100** continues transmitting RTP packets whose content corresponds to the portion **312** and not the portion **313**. Streaming server **100** may accomplish this by creating a virtual file **330**. Virtual file **330** may be created by streaming server **100** based on a combination of file **310** and requested skip **319**. In virtual file **330**, advertising **312** and content **313** may be displaced with respect to the normal order of file **310**. This displacement may be indicated in FIG. **3** by broken lines **321**, **322** and **323**. Portions **312** and **313** of the file **310** may correspond to portions **332** and **333**, respectively, of virtual file **330**. The start position and finish position of file **310** may correspond to the start position and finish position of file **330**, as shown in FIG. **3** by broken lines **324** and **326**, respectively. Additionally, the portion of the advertising portion that already has been played, corresponding to portion **311** of original file **310**, may correspond to portion **331** of virtual file **330**, up to the point at which the second PLAY message is received, shown by arrow **315** and broken line **325**.

The virtual file **330**, for example, may be a file that is created and stored in a database or other storage means of the streaming server **100**. However, this solution requires processing time in the streaming server **100** to create the virtual file **330**. To avoid this problem of processing time, virtual file **330** may be an object, e.g., a component programmed in the C++ language, that may run in streaming server **100**, and that may read the information from file **310** and transmit it to the RTSP and RTP modules of the streaming server **100** as though it were the file **330**, thus obviating the need to create the file **330**. Thus, file **330** may be created not as a stored file, but rather as virtual file that is accessed by means of the component that is run on streaming server **100**.

Streaming server **100** may receive the second PLAY message, which may instruct streaming server **100** to play the range starting at the point indicated by arrow **316**.

In response to this message, streaming server **100** may send a response signal, e.g., an RTSP RESPONSE message, to multimedia player **101**, indicating that the range starting at the point indicated by arrow **316** may begin playing. After this signal is sent, and in response to the received second PLAY message, streaming server **100** may transmit the requested range. Nevertheless, streaming server **100** may apply the requested range to virtual file **330**, instead of file **310**. This may cause advertising **312** not to be skipped, even though a skip to the point indicated by arrow **316** was executed. Rather, the content located at the corresponding point in virtual file **330**, e.g., corresponding advertising **332**, may be sent. Further, because multimedia player **101** receives a message indicating a successful execution of the command to play the range starting at arrow **316**, from the perspective of a viewer watching the content of multimedia player **101**, streaming server **100** appears not to have received the second PLAY message, instructing streaming server **100** to skip the advertising. Nevertheless, from the perspective of multimedia player **101**, streaming server **100** appears to have executed the command as requested. Further, streaming server **100** may transmit virtual file **330** using the same RTSP session that streaming server **100** used to transmit the multimedia file **310** prior to the virtual RTSP skip, thereby making the process transparent to multimedia player **101**.

In this way, the streaming server **100** may change from sampling file **310** to sampling virtual file **330** without modifying the parameters of the streaming transmission. For example, streaming server **100** may maintain the values of the

Pipelined-Request, Session and SSRC fields of the RTSP protocol, as well as the clocks used to calculate the timestamp value of the RTP packets and the “wall clock” used for the NTP timestamp fields of the SR-type control packets of the RTCP protocol.

In an embodiment of the invention, streaming server **100** uses the RTSP and RTP protocols to perform the virtual skip illustrated in FIG. **3** by taking advantage of some characteristics of the RTP and RTSP protocols, as described in more detail herein. Specifically, in order to perform a “virtual RTSP skip,” streaming server **100** may coordinates operation of the RTSP and RTP modules of the streaming server **100** using headers of the RTSP messages called “Range” and “RTP-Info” that allow the multimedia player **101** to know what portion of the file the information pertains to for each RTP packet it receives.

A brief explanation is provided herein of the meaning of some fields that are found in the RTP packets and which are used in the present invention. The detailed information about the RTP protocol may be found in the RFC 3550 specifications referenced previously in this application. The “Payload” field at the end of the RTP packet may comprise the content of the stream, e.g., audio, video, sampled audio, sampled video, and the like. The “Sequence number” of the RTP data packets may be a 16-bit integer number that may be configured to increase by one unit each time an RTP packet of a stream is transmitted. It may be used, such that the receiver of the RTP packets may identify lost data packets and may order the RTP packets which arrive to the receiver in a different order than the order in which they were sent. The “Synchronization source (SSRC) identifier” field may be a 32-bit field used as a unique identifier. Each RTP stream sent by each data source sends, e.g., each stream sent by streaming server **100**, has a unique SSRC identifier. If a server sends multiple streams in a multimedia transmission, such as audio and video, each stream may have its own SSRC identifier.

The “Timestamp” field may be a 32-bit integer number that may indicates the time when the sampling of the first byte of the content data of the RTP packet is performed, e.g., the time when the first byte of the Payload has been sampled. Each stream in the same RTSP session that is transmitted by RTP packets may use its own “RTP clock” to calculate the time at which the sampling of the first byte is performed. The RTP clock of each stream may be a clock that increases linearly and constantly. When the clock reaches its maximum value, e.g., $2^{32}-1$ for a 32-bit number, the clock may reset and start again at zero. For security reasons, the initial value of timestamp field may be randomly selected. The timestamp values of different streams of the same multimedia file that is transmitted using the RTP protocol may increase at different speeds and may take different initial values. In this way, for each stream that streaming server **100** transmits, streaming server **100** also may generate a timeline for that stream. For example, if a user is playing a content that has multiple streams, and the user delays the playing of that content for 20 seconds, e.g., the user sends a PAUSE command in the RTSP protocol, waits 20 seconds, and then sends a PLAY command, the RTP clocks of each stream that the RTP module of the streaming server **100** uses to calculate the timestamp may continue advancing regularly during those 20 seconds. When the user starts playing the content again, the value of the timestamp field of the new RTP packets that the streaming server **100** sends may have increased and may show the value of the clocks at the moment the sampling of the first byte of the content of each new RTP packet sent is performed.

Nevertheless, the order in which the data are sampled may not be the same order in which the data are sent, nor is this

necessary for a successful data transmission. For example, MPEG video may transmit the video frames in a different order from the sampling order. For this reason the receiver may use the timestamp field and not the “Sequence number” field to determine the order in which the content should be played. In the audio samples a clock may be used which may have the same increment speed as the sampling frequency, e.g., the clock associated with an RTP audio session may be increased by one unit each time the audio is sampled. For example, with an audio sampling frequency of 16,000 samples per second (16 kHz), if each RTP packet contains 20 milliseconds (ms) of audio, each consecutive RTP packet may increment the timestamp field by 320 units, e.g., $0.02 \text{ seconds} \times 16,000 \text{ samples/second}$, if there are no pauses between consecutive packets. The video samples may use a predetermined frequency, e.g., 90 kHz, or 60 kHz.

Multimedia player **101** may use the timestamp field of the RTP packets to calculate the moment of playing for each portion of the content sent in each RTP packet. The timestamp value of the RTP packets also may allow the multimedia player **101** to synchronize different streams of the same session. For example, an audio stream may be synchronized with a video stream, such that if the 20-minute and 10.4-second video moment is being played, the 20-minute 10.4-second audio moment also may be played.

The present invention may utilize the continuity of the timestamp field of the RTP packets. Specifically, streaming servers **100** may not rely on the timestamp data stored in the files that contain the multimedia content, but rather that the timestamp field of the RTP packets may be generated in the streaming server **100** in real time, which may taking into account the RTSP commands that the user sends to the streaming server **100**. The timestamp field of the RTP packets may not correspond to an index that indicates a portion of the multimedia file, but rather may correspond to a clock that operates in the streaming server **100**, and may be configured to increase linearly and constantly, and may not stop even though the user sends an RTSP PAUSE message. Streaming server **100** thus may use the RTSP and RTP protocols to transmit the virtual file **330** instead of the normal file **310** when there is an advertising skip.

The streaming server **100** may coordinate the RTSP module and the RTP module in order to perform the “virtual RTSP skip,” thereby “tricking” the multimedia player **101** by sending the virtual file **330** instead of performing the requested skip **319** and sending the content **313** of the file **310**. To do this, streaming server **100** may modify the normal relationship between the Normal Play Time (“NPT”) parameter of the RTSP messages and the timestamp field of the RTP packets.

The multimedia player **101** may not be capable of calculating, for the content of each RTP packet, to which portion of the total content that the content of the RTP packet belongs, solely by using the timestamp field of the RTP packets. To make this calculation, the multimedia player **101** may need an initial reference that relates a specific moment in the playing of the multimedia file to the values that each of the clocks, used to generate the RTP timestamp values of each of the streams that form the multimedia file, has at that specific moment. For example, the multimedia player **101** may need to know that the 3.25-second moment of the playing of a multimedia file corresponds to an RTP timestamp value=12345678 of the audio stream, and an RTP timestamp value=29567112 of the video stream.

With this initial reference information, the multimedia player **101** may calculate the playing moment that each received RTP packet of audio and video corresponds to, as a function of the RTP timestamp value of each packet and the

initial reference. Moreover, this initial reference information may allow the multimedia player **101** to synchronize the audio and video.

Streaming servers that use the RTSP and RTP protocols may send this information that relates one moment in the playing of a multimedia file to the RTP timestamp values of each stream to the multimedia player by using a plurality of, e.g., two, headers of the RTSP messages, which may be called “Range” and “RTP-Info.” These headers may be included in the RESPONSE messages that the streaming server **100** may send to the multimedia player **101** in response to the PLAY messages that the multimedia player **101** sends to the streaming server **100**.

The Range header of an RTSP message may indicate the play time range, and an initial moment that may be used as initial reference may be included. The Range header may code its information in various ways, e.g., by using Normal Play Time, e.g., “NPT,” which may indicate the absolute position of the stream relative to the start of the presentation. The NPT parameter may comprise a decimal fraction. The left part of the decimal fraction may be seconds or hours, minutes and seconds. The right part may be fractions of seconds. For example, “Range:npt=3.25-15” may be understood to mean that a portion of the content is being played that begins at 3.25 seconds and ends at 15 seconds of a multimedia file that may contain multiple streams. The NPT parameter is explained in detail in paragraph 3.6 of the RFC 2326, referenced previously. In many popular media players, e.g. the Media Player™ from Microsoft™, the NPT may be the clock that the multimedia player **101** displays for the user to associate with the content. In some systems, information in minutes and seconds may be shown in a lower right corner of multimedia player **101**. For example, multimedia player **101** may display “39:50” which may inform the user that the content shown corresponds to 39 minutes 50 seconds from the beginning of a video. In other embodiments, the Range header may also use other parameters to code its information, such as the SMPTE parameter, explained in paragraph 3.5 of RFC 2326. For simplicity, only the NPT parameter will be referenced with respect to these embodiments.

The field of the RTP-Info header of an RTSP message may comprise information related to the RTP packets of each stream transmitted using four fields called “url”, “ssrc”, “seq” and “rtptime.” The field called “rtptime” of the RTP-Info header may be the value of the timestamp field of the RTP packet whose content (payload) corresponds to the start of the range of the multimedia file indicated in the Range header. This information may be the initial reference that the multimedia player **101** may use to associate each RTP packet of each stream with a specific moment of the multimedia file. By using the combined information from the Range and RTP-Info headers included in the RTSP RESPONSE-type message that the streaming server **100** sends to the multimedia player **101** in response to the PLAY message, the multimedia player **101** may relate the NPT and timestamp values to each other and may associate each of the content of the file **310** to the content of each RTP packet.

When the streaming server **100** receives the second PLAY message requesting that the streaming server **100** transmit the content of the file **310** starting from point **316**, the streaming server **100** may respond with a RESPONSE message that may have a value of the Range header that indicates an initial range at point **336** and that may have a value of the RTP-Info header that indicates the value of the timestamp field of the RTP packets that the server will send with the content, corresponding to the requested range.

Multimedia player **101** may receive the RESPONSE message with the Range and RTP-Info values. In this way the multimedia player **101** may associate the value of the NPT parameter of the Range header, at the moment indicated by the arrow **336**, with the values of the rtptime parameter of each stream. When the multimedia player **101** calculates the corresponding portion of the file for each RTP packet it receives, the multimedia player **101** may use NPT value corresponding to the play moment of the file indicated with the arrow **316** as an initial reference.

Multimedia player **101** may indicate to the user that the RTP packets it is preparing to receive may correspond to the content portion **313**, but streaming server **100** may send the RTP packets that contain the information corresponding to the virtual file **330**, and not to the original file **310**. In the virtual file **330**, the portion of the file corresponding to a range that begins at the arrow **336** is the portion **332** that corresponds to advertising portion **312** of the file **310** that the multimedia player **101** is attempting to skip. In this way the streaming server **100** may “trick” the multimedia player **101** and prevents multimedia player **101** from skipping advertising **312**, since streaming server **100** continues sending RTP packets that transmit the portion **332** of the virtual file that corresponds to advertising portion **312** of file **310**.

Using this process, the streaming server **100** may perform the “virtual RTSP skip” and transmit the virtual file **330** instead of the original file **310** without the multimedia player **101** detecting the virtual skip.

In an embodiment of the invention, the relationship between the values of the Range and RTP-Info headers also may be used to allow the initial synchronization of the different streams, such that the multimedia player **101** may establish an initial relationship between the NPT parameter and the timestamps of the RTP packets of each stream. Nevertheless, synchronization between different streams, such as those between the audio stream and the video stream, may be lost in a transmission. Thus, standard streaming servers also may use the RTCP protocol to prevent and compensate for deviations in the synchronization that may occur in a long multimedia transmission that contains multiple streams. To prevent deviations in the synchronization of different streams, such as in audio and video streams, streaming server **100** regularly may send to the multimedia player messages, e.g., “SR” messages using the RTCP protocol. These SR messages may use a plurality of, e.g., three, fields to keep different streams of the same presentation synchronized. The fields may be called “SSRC,” “Network Time Protocol (“NTP”) timestamp” and “RTP timestamp,” for example.

The SSRC field may identify one stream of a presentation. The RTP timestamp field may be the value of the RTP clock associated with each stream when the streaming server **100** initiates the sampling of the content portion that is sent in each RTP packet, as discussed previously. The “NTP timestamp” field may be a reference clock that may be common to the different streams that the streaming server **100** sends in the same presentation, which also may be referred to as a “wallclock.” This clock may be common for the different streams of a presentation and may allow the multimedia player **101** to maintain the synchronization of the different streams in long transmissions.

By sending these three values in the SR messages, the streaming server **100** may indicate to the multimedia player **101** the correspondence between the value of the wallclock and the RTP timestamp values of the clock which may be used to calculate the RTP timestamp value of the RTP packets of each stream. The value of the RTP timestamp field of an SR message in the RTCP protocol of a specific stream may cor-

respond to the value of the RTP clock associated with the stream at the time indicated in the NTP timestamp value. In this way, the streaming server **100** also may allow synchronization of different streams in a long transmission.

In an embodiment of the invention, streaming server **100** may calculate the values of the fields of the SR messages of the RTCP protocol and the RTP packets from the virtual file **330** instead of the normal file **310**. In other words, the value of the RTP timestamp field of an RTP packet of a specific stream may correspond to the value of the RTP clock associated with the stream at the moment sampling begins of the portion of the virtual file **330**, which may be sent in the RTP packet.

Nevertheless, in FIG. 3, the area **335** of the virtual file **330** may not correspond with any portion of the original file **310**. Moreover, the virtual file **330** may be longer than the original file **310**. This may lead to a termination of the multimedia transmission before the user finishes viewing the content. This additional content portion which may not be viewed is illustrated in FIG. 3 as content portion **334**.

In another embodiment of the invention, as shown in FIG. 4, streaming server **100** may create a first virtual file **420** from the multimedia file **310** that may correspond to multimedia file **310** explained in FIG. 3. When streaming server **100** receives the SETUP and PLAY messages in order to play the content of a multimedia file **310**, streaming server **100** may begin the transmission from the beginning a virtual file **420** that may comprise one or more areas of non-obligatory advertising **426** and multiple messages **427**, **428** and **429**.

The non-obligatory advertising portion **426**, for example, may be related to the content portion, e.g., advertising about new movies. By increasing the length of the virtual file and including new content that may be played in the area of the "virtual skip" **335**, the multimedia transmission may be prevented from terminating before the user finishes viewing the content, as shown in area **334** of FIG. 3. Advertising portions **421** and **422**, and content portion **423** of virtual file **420** may correspond to advertising portions **311** and **312**, and content portion **313** of digital file **310**. Similarly to FIG. 3, advertising portion **442** of virtual file **440** may correspond to segment **422** of virtual file **420**, as shown by arrows **431** and **432**.

If a multimedia player sends a second PLAY message whose play range begins at **416**, the streaming server **100** may create a new virtual file **440** and may perform a "virtual skip" as explained above with respect to FIG. 3. The virtual RTSP skip of the file **420** to the file **440** may be indicated by the broken lines **431**, **432**, **433**, **434**, **435**, **436** and **437**. Once the virtual file **440** has been created, the streaming server **100** may transmit portions of the new virtual file **440** using the same RTSP session used to send the file **420**. By this "virtual skip," advertising portion **442**, which may correspond to advertising portions **422** and **312** of virtual file **420** and digital file **310**, respectively, may play prior to playing the content. Additionally, messages **427**, **428**, and **429** from virtual file **420** may correspond to messages **447**, **448**, and **449** in virtual file **440**, as shown by broken lines **434**, **435**, **436**, and **437**.

In this way, by increasing the size of the virtual file **420** that may be transmitted at the time the second PLAY message is received, the transmission may not end without playing the area **334**, as shown in FIG. 3. In the virtual file **440**, area **445** may correspond to a portion of the non-obligatory advertising **426**. This correspondence may be indicated in FIG. 4 with the broken line arrow **438**. Thus, if the user sends a third PLAY message that may begin the play range in the area **445**, the server may transmit the non-obligatory advertising **426**.

In the virtual file **440**, the advertising portion that already has been viewed, e.g., advertising portion **441** may correspond to advertising portion **421** in virtual file **420**, and adver-

tising portion **311** in file **310**. The beginning of file **310** may correspond to the beginning of virtual files **420** and **440**, as shown by broken lines **324** and **497**, respectively. Further, the point **315** at which the second PLAY message is received in file **310** may correspond to similar locations in virtual files **420** and **440**, as shown by broken lines **325** and **496**, respectively.

In an embodiment of the invention as shown in FIG. 5, when the user instructs multimedia player **101** to send the second PLAY message with start of play at **526**, the streaming server **100** may create a new virtual file **540** that first may transmit a multimedia message **547** before continuing to transmit the obligatory advertising **542** and the content **543**. In this embodiment, obligatory advertising **542** may be inserted into virtual file **540** after multimedia message **547** is inserted into virtual file **540**, as shown by broken lines **531** and **532**. Multimedia message **547** may correspond to multimedia message **527** of virtual file **520**, as shown by broken line **535**. The multimedia message **547** may make an indication to the user, e.g., that the user may be viewing content financed by advertising and that the advertising may not be skipped. In an embodiment of the invention, the streaming server **100** may end the multimedia transmission if the multimedia player **101** sends another PLAY message to skip the advertising.

In still another embodiment of the invention, shown in FIG. 6, a multimedia player **101** may receive a multimedia file **620**, and may send a second PLAY message with initial range at the point indicated by the arrow **626**, in order to skip the portion **622** with advertising. The streaming server **100** creates a new virtual file **640** that transmits a multimedia message **648**, which may correspond to message **628** of virtual file **620**, as shown by broken line **635**. Virtual file **640** also may include non-obligatory advertising **644**, which may correspond to non-obligatory advertising **624** of virtual file **620**. Multimedia message **648** may have a duration of 10 seconds, for example, and may notify the user that he must go back to see the advertising again within 10 seconds.

If the multimedia player **101** sends a reverse PLAY message within 10 seconds, returning to a play point prior to the point **625** that the streaming server **100** was transmitting when the user performed the skip, then the streaming server **100** may return to using virtual file **620** and may continue the advertising transmission **622**. In FIG. 6, the reverse PLAY message is indicated by line **649**.

If the multimedia player **101** does not send a reverse PLAY message within the 10 seconds of the message **648**, then the streaming server **100** continues transmitting the message **648** and ends the transmission of the multimedia file.

FIG. 7 shows another virtual file which, similarly to the embodiment shown in FIG. 6, may create virtual file **740**, and may transmit a message **748**, which may correspond to message **728** of virtual file **720**, as shown by broken line **735**, to the multimedia player **101**. Unlike the embodiment shown in FIG. 6, however, in FIG. 7, the streaming server **100** may not wait for a reverse PLAY message. In this embodiment, streaming server **100** simply may transmit message **748** and may end the transmission. The message **748**, for example, may notify the user that he has performed an unauthorized skip of the advertising and it is going to terminate the transmission.

In an embodiment of the invention, fast-forwarding through portions of content also may be prevented. In the RTSP protocol, the fast forward may operate, such that when the streaming server **100** is transmitting at twice the normal speed, the streaming server **100** may only send RTP packets only one out of every two video images to the multimedia

player **101**. If the speed is four times normal speed, the streaming server **100** only may send one out of every four images, and so on. The RTSP protocol may use a header called "Scale" that is explained in paragraph 12.34 of the RFC 2326, the related portions of which are described herein.

A value of 1 in the Scale header may instruct the streaming server **100** to transmit the content to the multimedia player **101** at normal play speed. If the Scale value is not 1, then the value may indicate the ratio at which content may be transmitted with respect to the normal play speed, e.g., a ratio of 2 instructs the streaming server **100** to transmit at twice the normal speed. Similarly, a ratio of 0.5 may instruct streaming server **100** to transmit the content at half the normal speed. A negative ratio may instruct streaming server **100** to play the content in reverse, e.g., in the direction that goes from the end of the content toward the beginning of the content.

A multimedia player **101** that is playing a multimedia file, e.g., a file containing content **420** in FIG. 4, may send a PLAY message to the streaming server **100** with a Scale value of 2, such that the advertising plays quickly. In an embodiment of the invention, the streaming server **100** may consider the fast forward as equivalent to skipping the advertising, and proceeding as explained in FIGS. 3 to 7.

Using the embodiment described with respect to FIG. 4 as an example, if the multimedia player **101** is playing the content of a file **420** and at point **325** the player sends a message to the server to increase the speed of play, the streaming server **100** may transmits the content at the requested speed. When the transmitted content reaches point **416** the multimedia player **101** again may send another PLAY message with a start range at **416** and normal play speed in order to view the content at normal speed. Upon receiving this second PLAY message, the streaming server **100** may detect that all of the advertising **422** has not been transmitted, and thereby may treat the fast forward command as a PLAY message, in the manner described previously. Other combinations that use messages like the ones explained in FIGS. 5, 6 and 7 are also applicable and make it possible to manage fast forward as a way of skipping different forms using different virtual files that may comprise messages for a user who is using a multimedia player.

In still another embodiment of the invention, streaming server **100** may choose among different types of virtual files, depending on the type of multimedia player **101** used in the equipment **102**. In order to detect the type of multimedia player, the streaming server **100** may use the header called "User-Agent" that indicates in the RTSP messages the multimedia player that is sending them. The RFC 2326 specifications, in paragraph 12.41, refer to paragraph 14.42 of the specifications for the HTTP protocol to explain the "User-Agent" field.

Although the RTSP protocol is a common specification, each multimedia player **101** may implement it in a particular manner. Moreover, there are parts of the RTSP protocol that the RFC 2326 considers optional. In an embodiment of the invention, streaming server **100** selects the mode of operation, e.g., one of the modes described with respect to FIGS. 4-7 based on the type of multimedia player **101**. By adapting the mode of operation of the streaming server **100** to each type of multimedia player **101**, the streaming server **100** also may detect if multimedia player **101** is an unauthorized type used to avoid viewing advertising or for unauthorized uses of the content and avoid it. Thus, the streaming server **100** may store this information about unauthorized players in its database **108**.

An example of unauthorized multimedia player is an application installed in the same equipment **102** as the multimedia

player **101** and that may not play the multimedia file while it is downloading, but rather may be limited to storing the content of the multimedia file in the equipment **102** in order to be able to play it later, directly from the equipment **102** without needing to connect to the streaming server **100**, by taking advantage of the multimedia player cache **120** or other type of local memory device (outside server **100**) that is accessible to multimedia player **101**.

When the streaming server **100** detects an unauthorized player, streaming server **100** may send a RESPONSE error message to the multimedia player or not process the PLAY message and not send the corresponding RESPONSE message, or streaming server **100** may send a RESPONSE message as though it had processed the PLAY message, but nevertheless may ignore it. It may also occur that a user uses an authorized multimedia player **101** in a way that avoids viewing the advertising. For example, a user may use an Internet browser that may comprise a plug-in that is a multimedia player **101**, but instead of playing a multimedia file, the user may use the browser's "Save As" option to keep the multimedia file without playing it while it is downloading. In this case, streaming server **100** may detect this unauthorized use, for example analyzing the RTCP control messages that the multimedia player **101** sends to the streaming server **100** and may terminate the transmission if it detects that the multimedia player **101** is not playing the multimedia file while it is being downloaded.

The streaming server **100** may prevent the multimedia player **101** from being able to play the content of a file more than once without seeing the advertising again. Thus, the streaming server **100** may generate a new virtual file, e.g. the virtual file **420** shown in FIG. 4, under some circumstances that are explained herein. The streaming server **100** may account for time elapsed since a transmission of the content portion that a user instructs a multimedia player **101** to request to play again. For example, a user may use a multimedia player **101** to view all of the advertising before viewing a movie that is transmitted from the streaming server **100**, and may wish to see specific scenes again within a few minutes or hours, which may be allowed, but after a few days or weeks, may be disallowed by streaming server **100** unless the user views the advertising portion again.

In order to manage this operation, streaming server **100** may use the "Cache-Control" and "Expires" headers in the RTSP messages, or similar type messages, that streaming server **100** sends to the device **102** and multimedia player **101**, e.g., in the RESPONSE message that streaming server **100** sends in response to a SETUP message from the multimedia player **101**.

The Cache-Control header and its operation are explained in paragraphs 12.8 and 13 of the RFC 2326. The Expires header is explained in paragraph 12.19 of the RFC 2326. The Cache-Control header may regulate the operation of the different cache devices located between the streaming server **100** and the multimedia player **101**, including for example a cache **120** of device **102** accessible by multimedia player **101**. The Expires header may report when a multimedia content or a description file of a multimedia content expires. A cache device may be configured to disallow the transmission of expired content, and to contact the streaming server **100** in order to receive updated content. By using the headers, streaming server **100** may operate to create a new virtual file with advertising, or allow the advertising to be skipped, depending on the time elapsed since it transmitted a multimedia file.

For example, the streaming server **100** may use the "must-revalidate" value in the Cache-Control header of the

RESPONSE message that streaming server **100** sends to the multimedia player **101** in response to a SETUP message. This value of the Cache-Control header may indicate to the cache devices that the cache devices should not transmit an expired content without first validating it with the streaming server **100**. The content may expire at the time indicated in the Expires header. This method of marking content which has not actually expired as expired is not provided for in the RTSP. The marking of unexpired content as expired may be carried out in order to, for example, allow the creation of a new virtual file in the streaming server **100**, and to allow insertion of new advertising when a certain amount of time has elapsed, e.g., 24 hours. Other embodiments of the invention may use the Cache-Control and Expires headers in other ways in order to accomplish the same objective. For example, streaming server **100** may give the "no-cache" value to the Cache-Control header, indicating that the multimedia transmission may not be stored in any cache. Streaming server **100** also may use a cache control or other system, depending on the type of multimedia player used.

Although in various implementations the streaming server **100** makes use of headers to control the availability of data stored in a cache, other implementations of the present invention are not so limited. For example, in alternative embodiments, server **100** may implement other types of control functions to control cache devices or other types of data storage devices in order to achieve the same or similar results.

FIG. **8** illustrates a verification process used by the streaming server **100** to verify whether the advertising has been transmitted, according to an embodiment of the invention. The streaming server **100** may receive a PLAY-type RTSP message at step **801**, which may comprise a Range header. The Range header may comprise an initial range and final range, and the initial range may not correspond with the beginning of the multimedia file. At step **802** the streaming server **100** may perform the verification of whether RTP packets with all of the advertising have been transmitted from the multimedia file that may be located prior to the initial range.

If the streaming server **100** has transmitted all of the advertising from the multimedia file prior to the initial range, then at step **803** the streaming server **100** may process the PLAY message normally and may transmit the range of multimedia content indicated in the PLAY message. In this way, a user may move about freely in the portions of the file whose advertising the user has already viewed. For example, if all of the advertising is at the beginning of the file, this may allow the user to instruct the multimedia player **101** to go forward or backward freely in the multimedia file in order to choose the content that the user wants to see. Nevertheless, if in the verification at step **802**, the streaming server **100** detects that all of the advertising has not been transmitted from the multimedia file before the initial range, the streaming server **100** may go to step **804**, in which a PLAY message which contains instructions to skip an advertisement may be processed by the streaming server **100**. This may cause streaming server **100** to execute one of the operations to continue playing the advertising, e.g., the operations described with respect to FIGS. **4-7**. At step **805**, the process may terminate.

With reference to FIGS. **1A** and **9**, a method of transmitting streaming data from a server **100** to a data storage medium **120** accessible to a multimedia player **101** in one implementation is disclosed. In the discussion that follows, and by way of example, the data storage medium **120** is often described as a cache device. In addition, the RTSP is disclosed as the communication means used by the streaming server **100** to control accessibility of data in the cache by the multimedia

player **101**. It is important to understand, however, that the implementations described herein are not limited to any particular type of memory device nor are they limited to any particular communications protocol for controlling accessibility to the data stored in the memory device.

FIG. **9** shows a file **910**, containing an advertising portion **912**, and several content portions, namely **911**, **913** and **914**. File **910** might be, for example, a multimedia file or a container file stored in the database **108** of the streaming server **100**. For the sake of simplicity, file **910** is shown with only one advertising portion and three content portions. It is appreciated that none of the implementations disclosed herein are limited to multimedia files have any particular number of advertising portions or content portions. In addition, multimedia file **910** may contain multiple streams, such as audio and video streams, which are not illustrated in FIG. **9**.

In one implementation, multimedia file **910** is a file previously stored in data base **108**. In other implementations, server **100** accesses one or more data sources located within the server or outside the server to construct multimedia file **910**. This may occur at the time a multimedia request is received in the server **100** from multimedia player **101**, or at some time prior or after such request. In one implementation, multimedia file **910** comprises streaming data portions having an order of transmission, such as in the following order: **911**, **912**, **913** and **914**. In some implementations the order of transmission of the streaming data portions is consistent with the sequence in which the data portions are designated to be played by the multimedia player **101**. In other implementations, the order of transmission of the data portions is not consistent with the intended play sequence of the data portions. The implementations of FIG. **9** represent the former with arrows **T0**, **T1**, **T2**, **T3** and **T4** indicating the start and/or end moments of portions **911**, **912**, **913** and **914** of multimedia file **910**. In one implementation, moment **T0** corresponds to the start time of content portion **911** and also to the beginning of the presentation. In such an instance, **T0** may have a time value of zero seconds, but may be any other value having a known relationship with at least **T1**, and preferably also with **T2**, **T3** and **T4**. In some implementations one, some, or all of **T0**, **T1**, **T2**, **T3** and **T4** have a direct correspondence with a normal play time (NPT) of the streaming data. The NPT may correspond to a clock the viewer associates with the playing moment of a multimedia files. This value is often digitally displayed on the device **102** and advances normally when the multimedia player is in normal play mode (scale=1), advances at a faster rate when in fast forward mode (high positive scale ratio), decrements when in reverse mode (high negative scale ratio) and is fixed in pause mode navigation mode. In other implementations, one, some, or all of **T0**, **T1**, **T2**, **T3** and **T4** do not directly correspond with the NPT, but has some other known association with the NPT. In addition, the NPT need not correspond to a clock that is viewable to a user.

In one implementation, data portion **913** is an advertising-sponsored content portion that is designated as being reproducible or playable in device **102** only after all, substantially all, or at least a portion of the advertising portion **912** has been played by the multimedia player **101**. For discussion purposes, in such an instance, data portion **912** is referred to herein as an obligatory advertising portion.

As previously discussed, upon receiving a request for multimedia data from the multimedia player **101** (e.g., in the form of an RTSP SETUP message and a subsequent RTSP PLAY message), streaming server **100** may initiate the transfer of a multimedia file, such as file **910**, to the multimedia player **101** in a manner that enables the multimedia player to start playing

the streaming data as it is being downloaded from the server **100**. In one implementation, while the multimedia file **910** is being downloaded from server **100**, all or part of the file **910** is also stored in a local data storage medium **120** that is accessible to the multimedia player **101**. The term local data storage medium refers to any data storage medium located outside server **100** (e.g., memory **120**, memory **130**, etc.), and in many instances serves the purpose of reducing latency. The local data storage medium **120** may be a cache, flash memory, or any other suitable data storage device.

In one implementation, at least a portion of multimedia file **910** is transmitted to the local data storage medium **120** prior to any portion of the file being played by the multimedia player **101**. In another implementation, the advertising-sponsored content portion **913** is not transmitted to the local data storage medium **120** until the server **100** has determined that all, or substantially all, of the obligatory advertising portion **912** has been played by the multimedia player **101**. In another implementation, the advertising-sponsored content portion **913** is not transmitted to the local data storage medium **120** until the server **100** has determined that all, or substantially all, of the obligatory advertising portion **912** has been played by the multimedia player **101** and upon subsequently receiving a play request from the multimedia player. In another implementation, the data portions of the multimedia file **910** do not reside within, or are otherwise made accessible to the multimedia player **101**, via a single server. For example, in one implementation the obligatory advertising portion **912** is accessed through a first server while the advertising-sponsored content portion **913** is accessed through a second server. In another implementation, the obligatory advertising portion **912** is transmitted to the data storage medium **120** prior to the advertising-sponsored content portion **913** and at a first transmission rate. The advertising-sponsored content portion **913** is in turn transmitted to the data storage medium **120** at a second transmission rate slower than the first transmission rate at least until the server **100** has determined that all, or substantially all, of the obligatory advertising portion has been played by the multimedia player **101**.

With continued reference to FIG. 9, reference numeral **920** represents a memory location or locations in cache **120**. In the example of FIG. 9, arrow **930** represents the part of file **910** which has been stored in the cache **120** at a given time. In one implementation, multimedia player **101** may be playing content portion **911** while portions **912**, **913** and **914** are transmitted and stored in cache **120**. Reference numerals **921**, **922**, **923** and **924** correspond to data portions **911**, **912**, **913** and **914** of file **910** which have been or are to be downloaded into cache **120**. Such correspondence is indicated by dashed lines **940**, **941**, **942** and **943**. In the example of FIG. 9, a portion of the cache **120**, represented by reference numeral **924**, has not yet been filled with the contents of content portion **914** of multimedia file **910**. In some implementations, data portions **921**, **922**, **923** and **924** comprise all of the data existing in data portions **911**, **912**, **913** and **914**, respectively. In other implementations data portions **921**, **922**, **923** and **924** comprise less than all of the data existing in data portions **911**, **912**, **913** and **914**. For example, some header information or metadata information may not be stored in cache **120**. Also, in some instances the server **100** may vary the quality of the streaming data transmitted to device **102** that results in a subset of the data being sent from the server **100** to device **102**. This may occur when a low quality download is requested from the multimedia player **101**. There may also be other instances when the server **100** detects or is made aware of, for example, transmission latency or cache memory storage problems that

result in the server **100** sending to device **102** less than all the data of one or more of the data portions **911**, **912**, **913** and **914**.

Upon transmitting the data portions **911**, **912**, **913** and **914**, or a subset thereof (e.g., data portions **912** and **913**), the transmission occurs in a manner so that the data portions **921**, **922**, **923** and **924** that may become stored in cache **120** have a known relationship to data portions **911**, **912**, **913** and **914**. The known relationship may take any form that permits the server **100** to associate a moment of data portions **921**, **922**, **923** and **924** as they are played by the multimedia player (e.g., NPT) with the same, or substantially same, moment of data portions **911**, **912**, **913** and **914**. In one implementation the known relationship is based on the NPT. For example, **T0** may mark the beginning of content portion **911** and may correspond to a NPT 00:00:00 (zero seconds), **T1** may mark the beginning of obligatory content portion **912** and may correspond to a NPT of 00:05:00 (five minutes), **T2** may mark the beginning of advertising content **913** and may correspond to a NPT of 00:10:50 (ten minutes and fifty seconds), **T3** may mark the beginning of content portion **914** and may correspond to 01:27:00 (one hour and twenty-seven minutes), and **T4** may mark the end of the content portion **914** and may correspond to 02:00:00 (two hours). Hence, in accordance with this example, server **100** may receive NPT information from the multimedia player **101** and determine from this information the moment of the multimedia file **910** that is being played, or attempting to be played, by the multimedia player. In other implementations different methods are used to make the known relationship. In one implementation the multimedia file **910** comprises sequence data that is transmitted along with the data portions **911**, **912**, **913** and **914**. The sequence data may be transmitted within a header of the packets transmitted from the server **100**. In another implementation, the known relationship is based on a combination of NPT and sequence data. Other methods of establishing the known relationship may also be used.

The use of a local data storage medium, such as cache **120**, to permit the multimedia player **101** to access the requested multimedia information provides a number of advantages in the transmission of multimedia files. However, it also presents a problem for the streaming server **100** because the multimedia player **101** may send a message to the streaming server to skip all or part of obligatory advertising portion **912** at a time when the streaming server has already transmitted to the cache **120** all or a part of advertising-sponsored content portion **923** that corresponds to content **913** of multimedia file **910**.

A skipping of obligatory advertising portion **922** can occur in several ways. As depicted in FIG. 9 by arrow **931**, the multimedia player **101** may initiate a PLAY-type message, for example, in the RTSP protocol, for the purpose of causing the play to commence after the beginning of the obligatory advertising portion **922**. An unauthorized skipping of obligatory advertising portion **922** may also occur by the multimedia player **101** initiating a request to fast forward through at least a portion of obligatory advertising portion **922**.

In one implementation, upon the server **100** detecting, or otherwise being made aware that the playing of all or part of the obligatory advertising portion **922** is attempting to be avoided by the multimedia player, the server **100** sends to the device **102** a message with data storage medium control information for the purpose of preventing or inhibiting the advertising-sponsored content portion **923**, and in some instances content portion **924**, stored in the data storage medium **120** from being played by the multimedia player **101** or otherwise reproduced within or by device **102**. In one implementation this is accomplished by the server **100** sending to device **102**

data storage control information that functions to cause the advertising-sponsored content portion **923** in the data storage medium **102** to be marked as expired. In one implementation, in the event that not all of multimedia file **910** has been transmitted to data storage medium **120**, the server **100** also terminates the transmission of the multimedia file. In one or more of the implementations herein described, the server **100** also sends to the multimedia player **102** a message that informs the user of an unauthorized navigation request.

With continued reference to FIG. **9**, another skip, indicated by the arrow **932**, involves the multimedia player **101** sending a type of reverse navigation control message to cause the play moment of the advertising-sponsored content portion **923** stored in cache **120** to be replayed by the multimedia player. In the same way as in the previous skip **931**, the skip **932** may be performed by the multimedia player by the sending of a PLAY-type message in the RTSP, which notifies the streaming server **100** of the intent to play the content from moment **T2**. In the skip indicated by arrow **931** the multimedia player **101** attempts to skip obligatory advertising portion **922**. In the skip indicated by arrow **932** the multimedia player is not attempting to avoid the obligatory advertising portion **922**. However, both skips, **931** and **932**, may be executed by the multimedia player **101** using the same message (e.g., an RTSP PLAY-type message requesting a play from moment **T2**).

In one implementation, streaming server **100** distinguishes between the two types of skips **931** and **932** by determining if the obligatory advertising portion has been played by multimedia player **101**. If the server **100** determines that the obligatory advertising portion has not been played by the multimedia player **101**, the server interprets the navigation message sent by the multimedia player to be an unauthorized skip **931** and inhibits or prevents full access to the associated advertising-sponsored content portion by the multimedia player until the obligatory advertising portion has been played. The server may implement any one of a variety of methods, including those discussed above (or combinations thereof), to inhibit or prevent the advertising-sponsored content portion from being played by the multimedia player. If, on the other hand, the server **100** determines that the obligatory advertising portion has been played by the multimedia player **101**, the server interprets the navigation message sent by the multimedia player to be an authorized skip **932** and does not inhibit or prevent the advertising-sponsored content portion from being played by the multimedia player.

In accordance with one implementation, server **100** maintains a first time variable whose value is responsive to the multimedia player navigation mode messages received in the server. The navigation modes being, for example, play, fast forward, reverse, rewind, pause, stop, etc. In one implementation the first time variable assumes, upon receiving a navigation message from the multimedia player **101**, a value corresponding to a moment (**T0**, **T1**, **T2**, **T3**, **T4** or any moment between) of multimedia file **910**. In one implementation the first time variable takes the NPT clock value of the multimedia player **101** when the navigation message was sent. In such an implementation, server **100** determines that the playing of all or a portion of the obligatory advertising portion is attempting to be avoided by the multimedia player upon receiving a fast-forward, skip, or like navigation message from the multimedia player when the first time variable has a value corresponding to a moment between **T1** and **T2**.

In other implementations, server **100** uses a second time variable that may be used in lieu of the first time variable or in conjunction therewith. The second time variable permits the streaming server **100** to be aware of which part of the multi-

media file is being played by the multimedia player **101**. As explained above, the RTP protocol uses a clock associated with each stream, for instance, an audio or a video stream, which is used to calculate the timestamp field of each RTP packet. The clock associated with each stream is not responsive to the multimedia player navigation messages received in the server **100** and continues to run even when the streaming server receives a pause message, such as a PAUSE-type RTSP message. The second time variable is maintained by the streaming server **100** and has a value that alters differently than the timestamp clock. In one implementation the value of the second time variable increments, decrements or ceases to increment or decrement in response to the navigation messages received from the multimedia player **101**. According to this method, server **100** makes use of the second time variable in determining which part of the multimedia file **910** is being played, or attempting to be played, by the multimedia player **101**. This permits the streaming server **101** to determine if an obligatory advertising portion has been played by the multimedia player prior to the server enabling the multimedia player full access to an associated advertising-sponsored content portion.

As explained above, a multimedia player PLAY message includes a parameter known as RANGE indicating the part of the multimedia file **910** that the multimedia player wishes to receive. In accordance with one implementation, when the streaming server **100** receives a PLAY-type message with a RANGE parameter indicating a playback range—for example, showing a starting and ending time, or merely a starting time—the server **100** updates the value of the second time variable to the starting time indicated in the RANGE parameter. When the second timer variable has been updated with the initial value, the streaming server **100** increases the second time variable value in response to multimedia player navigation messages received from the multimedia player **101**. For example, when the streaming server receives a PAUSE-type message from the multimedia player, the streaming server stops incrementing the second time variable. This enables the streaming server **100** to know the moment of the multimedia file **910** being played in the multimedia player **101** regardless of the amount of content that has been transmitted to and received in the cache **120**.

In one implementation the second time variable maintains a value in seconds. In the example that follows, the second timer variable uses milliseconds as the measuring unit. The use of other time increments may also be used.

The following are examples that illustrate the use of the second time variable maintained by server **100**. Table 2 represents data that may be stored in server **100** that includes the beginning and end time of the multimedia file **910** data portions.

TABLE 2

| Start Time | End Time | Content Type |
|------------|----------|--------------------------|
| T0 | T1 | Content |
| T1 | T2 | Obligatory Advertising |
| T2 | T4 | Advert-Sponsored Content |

In accordance with one example and with continued reference to FIGS. **1A** and **9**, the server **100** receives a PLAY-type message from multimedia player **101** and in response begins the transmission of multimedia file **910** from the moment **T0**. Upon receiving the message from the multimedia player **101**, the streaming server **100** initializes the second time variable at 0.000 milliseconds and begins incrementing the second

time variable value in one millisecond intervals. When the second time variable has value corresponding to moment T3, the multimedia player 101 sends a navigation message to the streaming server 100 that represents a request to play advertising-sponsored content portion 923 from its beginning which is recognized by the server as moment T2. This message corresponds to the skip 932 discussed above. Upon receiving the navigation message, the streaming server 100 determines by use of the second time variable that the navigation message sent by the multimedia player was sent at a moment corresponding to T3. This implies that the obligatory advertising portion has been satisfactorily played by the multimedia player and that the skip is an authorized skip. As a result, the server takes no action to impede full access by the multimedia player to the advertising-sponsored content portion 923 stored in cache 120.

In another example, the multimedia player 101 initially sends a PLAY-type message to request that the streaming server 100 transmit multimedia file 910 starting at moment T0. Upon receiving the first navigation message, the streaming server initializes the second time variable to 0.000 milliseconds and begins incrementing the second time variable value in one millisecond intervals. When the second time variable has value corresponding to moment T1, the multimedia player 101 sends a second navigation message to the streaming server 100 that represents a request to play advertising-sponsored content portion 923 without having first played the associated obligatory advertising portion. This navigation message corresponds to skip 931 shown in FIG. 9. Upon receiving the second navigation message, the streaming server checks the value of the second time variable which has a value corresponding to moment T1. The streaming server then checks in Table 2 if there is any obligatory advertising between moment T1 and moment T2. Because Table 2 indicates that an obligatory advertising portion does exist between moments T1 and T2, the server 100 determines that the multimedia player is attempting an unauthorized skip. In response to receiving the unauthorized skip request the server 100 inhibits or prevents the multimedia player from playing all or a portion of the advertising-sponsored content portion. In one implementation this is accomplished by the server 100 sending to device 102 a cache control message to mark the advertising-sponsored content portions 923 and 924 stored in the cache as expired and terminating the transmission of any part of the multimedia file that may be in progress. The server may take other actions like, for example, those previously described.

The second time variable can be used in a similar way to determine when or if the multimedia player is attempting to fast forward through a part of the obligatory advertising portion 922. In response to receiving an unauthorized fast forward request from the multimedia player, the server 100 inhibits or prevents the multimedia player from playing all or a portion of the advertising-sponsored content portion. In one implementation this is accomplished by the server 100 sending to device 102 a cache control message to mark the advertising-sponsored content portions 923 and 924 stored in the cache as expired and terminating the transmission of any part of the multimedia file that may be in progress. The server may take other actions like, for example, those previously described.

In one implementation, the server 100 tracks the duration and/or scan rate of the fast forward request and only takes action to restrict access to the advertising-sponsored portion upon determining that a threshold amount of the obligatory advertising content has been avoided. This function avoids disrupting the streaming session in the event a user inadvertently

only momentarily initiates a fast forward request that avoids only a small part of the obligatory advertising portion. In one implementation the threshold amount is related to a fixed duration. In other implementations the threshold amount varies depending on the overall duration of the obligatory advertising portion. In one implementation the server 100 tracks the number of unauthorized fast forward requests it receives and takes action to restrict access to the advertising-sponsored content when the number of fast forward requests reach a determined threshold, regardless of the amount of obligatory advertising content that has attempted to be avoided.

In one implementation, after having sent a message to mark content stored in cache 120 as expired, the streaming server then transmits new data to the cache 120 to replace that which has been marked as expired. This may involve retransmitting an entirely new multimedia file or replacing only those portions that have been marked as expired. In one implementation the server may mark as expired portions 922, 923 and 924 and subsequently retransmit using the same streaming session new data portions comprising at least all, or substantially all of the data that existed in data portions 922, 923 and 924. In one implementation the server reorders or displaces the play sequence of at least some of the data so that a subset of what was once a part of advertising-sponsored content 923 is positioned before obligatory advertising portion 922, with the remaining data of what was data portion 923 placed after the obligatory advertising portion. This enables a user of the multimedia player to view more media content before being obliged to view an advertisement. The purpose being to entice the user to continue the viewing experience without initiating another attempt to avoid the obligatory advertising portion. In one implementation, if another attempt to avoid all or a portion of the obligatory advertising portion is detected by the server 100, the server takes any one of a variety of actions to inhibit or prevent any advertising-sponsored content from being played by the multimedia player and ends the streaming session.

In the previous example, it is not necessary that the server 100 retransmit the same obligatory advertising content or the same advertising-sponsored content. For example, in one implementation the server retransmits an obligatory advertising portion with different content than the first. For example, the new obligatory advertising portion may comprise all or a subset of the first obligatory advertising portion with additional advertising content. The new obligatory advertising portion may also comprise all new content. In one implementation selection of the content to be included in the new obligatory advertising portion is based on the actions taken by the user of the multimedia player during the streaming session. For example, if during the streaming session a user of the multimedia player has previously viewed all or substantially all of an advertisement, the server may select to retransmit the same advertisement or an advertisement of a similar nature. The similar nature may be based on product or service type, duration of the advertisement, etc. In other implementations the server 100 may select new advertising content based on the perceived attention span or viewing habits of the user of the multimedia player. For example, if during the streaming session a number of fast forward and/or skip type messages are received in the server 100, the server may in response to receiving an unauthorized navigation message from the multimedia player retransmit new content with more, yet shorter, advertising portions dispersed between more, yet shorter, content portions.

FIG. 10 shows other examples where after having marked the advertising-sponsored content portion 923 and 924 as

being expired, the server initiates transmission of streaming data once again using the same streaming session as before. In the examples of FIG. 10, the streaming server is capable of using any of the methods previously described in conjunction with FIGS. 3 through 7. For example, as shown in FIG. 10, the streaming server 100 creates a new file or virtual file 1030, wherein at least some of the contents of multimedia file 910, as shown by the dashed lines 1022, 1023 and 1024, are displaced. In one implementation the displaced content also includes a new time stamp variable. In file 1030, data portions 1031 and 1032 correspond to the data portions 911 and 912 of multimedia file 910, respectively. Data portion 1033 corresponds to data portion 912 and data portion 1034 corresponds to data portions 913 and 914. Subsequent to the creation of the new file 1030, the server transmits to device 102 the obligatory advertising portion 1033 where it is stored in memory location 923b of cache 120. Advertising-sponsored content portion 1034 is in turn transmitted by the server to device 102 where it is destined to be stored in memory location 924b of cache 120. As a result of the displacement, when the multimedia player performs, for example, skip 931 it access the same obligatory advertising portion which now resides in memory location 923b which corresponds to moment T2. In this manner, when the multimedia player performs skip 931 to jump an obligatory advertising portion, the streaming server 100 overrides the contents of at least part of the cache memory and replaces it with the obligatory advertising to prevent the multimedia player from skipping the obligatory advertising.

A problem that may occur when a user of the multimedia player initiates several skips in a streaming session. For example, the multimedia player may begin playing the content of multimedia file 910 from moment T0 and continue playing until moment T3. At moment T3 the player may skip back to moment T1 and then skip forward from moment T1 to moment T2 to avoid replaying the obligatory advertising portion 922, previously played by the multimedia player. In this case, the streaming server may consider the skip from T1 to T2 as an unauthorized skip.

To avoid this problem, in one implementation the streaming server 100 may make use of a third time variable, known as time3, which takes the value of zero at the start of the streaming session and assumes the maximum value reached by the second time variable during the streaming session, for example by executing the following pseudocode in the streaming server:

```
If time>time3 then time3=time
```

The “time” may be based on the first time variable, second time variable or any other suitable time variable. By use of the time3 variable, the streaming server 100 knows the most advanced moment of the multimedia file 910 that has been played by the multimedia player 101. For example, in one implementation when the multimedia player has played the content that spans between corresponding moments T0 to T3, the time variable increments from T0 to T3 and the time3 variable increments at the same time until reaching the value time3=T3. When the multimedia player goes back to a moment corresponding to T1, the time variable takes the T1 value, but the time3 variable remains at the T3 value because T3>T1. When the multimedia player 101 initiates a skip corresponding to moments T1 to T2, the streaming server 101 determines that the destination point of the skip, i.e. T2, is lower than the value stored in the time2 variable, i.e. T3, and considers the skip to be an authorized skip since the obligatory advertising portion has been previously played by the multimedia player in the same streaming session. In one

implementation the server uses a variable other than time, such as sequence data to achieve the same objective.

In one implementation, the cache 120 is managed from the multimedia player 101 by means of an application called “user agent cache” running on the device 102. In another implementation, a proxy cache device external to device 102 and situated between the streaming server 100 and device 102. Moreover, as previously discussed, the cache itself may reside in a proxy situated between the streaming server 100 and device 102.

The streaming server 100 may indicate that all or a part of the content stored in cache 120 has expired in several way. In one implementation, using for example an RTSP streaming protocol and the “MUST-REVALIDATE” directive, the streaming server uses the Expires header to associate an expiry date with the content transmitted to cache 120. For example, this date may be earlier than the date on which the transmission is made so that, according to the abovementioned operation of the “MUST-REVALIDATE” directive in the RTSP protocol, the device controlling cache 120 will check whether the content of the cache has expired every time the multimedia player sends a navigation message. When the streaming server 100 detects that all or a portion of an obligatory advertising portion is attempting to be avoided by the multimedia player 101, the server 100 sends a message to the multimedia player or device managing the cache memory indicating that the content of the cache memory has expired. If the streaming server does not detect an unauthorized avoidance of an obligatory advertising portion, it sends a message indicating that the content of the cache memory has not expired or simply sends no message at all related to the expiry of the cache memory.

In another implementation the streaming server 100 sends a message to device 102, or the device that manages the cache 120, that indicates a certain part or all of the cache content must be made inaccessible to the multimedia player upon the server determining that all or a portion of an obligatory advertising portion is attempting to be avoided by the multimedia player. For example, a message may indicate that advertising-sponsored content portion 923 stored in the cache 120 has expired by specifying the range of data portion 923, (i.e. the range between moments T2 and T3). Subsequently, the streaming server 100 transmits additional data to multimedia player or device managing the cache to replace in the cache those portions that were marked as expired or otherwise cancelled or deleted from the cache 120. In accordance with this implementation, the messages sent by the server 100 do not use a field to store a date and a time when the content will expire. Instead, the server 100 uses specific messages that allow it to update a part of the cache memory.

Although many of the implementations have been explained using the RTSP protocol, it is important to note that protocols other than RTSP that allow the progressive downloading and viewing of multimedia files, such as Adobe Flash, Adobe RTMP, Microsoft Silverlight, HTML5.0, etc., may also be used.

In one implementation, as illustrated in FIG. 11, the advertising-sponsored content portion 913 is not transmitted to cache 120 until the server 100 has determined that all, or substantially all, of the obligatory advertising portion 912 has been played by the multimedia player 101. In accordance with one method, the streaming server first transmits to the multimedia player or device that manages cache 120, data portions 911 and 912, which are stored in the cache memory locations 921 and 922. The streaming server does not transmit advertising-sponsored content portion 913 to device 102 or the device that manages the cache 120 until the server has

determined that the multimedia player has played all, or substantially all, of obligatory advertising portion 922. In one of a variety of methods may be used by the server 100 to determine when all, or substantially all, of the obligatory advertising portion has been played by the multimedia player, including those methods previously described herein. Upon the streaming server determining that the multimedia player has played all, or substantially all, of obligatory advertising portion 922 stored in the cache 120, the streaming server then initiates transmitting to device 120 advertising-sponsored content portion 913.

In one implementation, in order to avoid the multimedia player having to wait to receive the contents of the advertising-sponsored content portion, the streaming server 100 starts transmitting the data portion 913 to device 102 moments (e.g., a few seconds) before the multimedia player completes playing the obligatory advertising portion. In one implementation the streaming server 100 determines how soon to send the advertising-sponsored content portion by take latency into account—that is, the time it takes a data packet to be reach the multimedia player 101 after it has been sent from the server 100. In one implementation, the streaming server 100 uses the aforementioned RTCP protocol to determine latency.

In one implementation, as illustrated in FIG. 12, streaming server initially transmits a small portion of advertising-sponsored content portion 913, for example 30 seconds of content, which is stored in the memory location 1121 of cache 120 to avoid the multimedia player having to wait a few seconds after it has finished playing part 922 with advertising. When the server determines that all, or substantially all, of the obligatory advertising portion has been played by the multimedia player, the server then initiates transmission to device 102 the remainder of multimedia file 910.

While the invention has been described in connection with preferred embodiments, it will be understood by those skilled in the art that other variations and modifications of the preferred embodiments described above may be made without departing from the scope of the invention. Other embodiments will be apparent to those skilled in the art from a consideration of the specification or practice of the invention disclosed herein. It is intended that the specification and the described examples are considered as exemplary of the claimed invention, the scope of which is indicated by the following claims.

What is claimed is:

1. A method comprising transmitting streaming data to a data storage medium that is accessible to a device having a multimedia player, the streaming data comprising an advertising-sponsored content portion and an associated obligatory advertising portion, the obligatory advertising portion being first transmitted to the data storage medium; in response to a determination that the obligatory advertising portion has been played in the multimedia player, transmitting the advertising-sponsored content portion to the data storage medium; and sending a message to the data storage medium to mark the advertising-sponsored content portion as expired upon receipt of a navigation message requesting an unauthorized skip.
2. The method according to claim 1, wherein the obligatory advertising portion is transmitted to the data storage medium by a first server and the advertising-sponsored content is transmitted to the data storage medium by a second server.
3. The method according to claim 1, wherein the data storage medium is a cache.

4. The method according to claim 1, wherein the streaming data is transmitted to the data storage medium in packets using a version of the Real-time Transport Protocol (RTP) protocol.

5. The method of claim 1 wherein the advertising-sponsored content portion is transmitted to the data storage medium in response to receiving a play request from the multimedia player.

6. A method comprising:

transmitting streaming data to a data storage medium that is accessible to a device having a multimedia player, the streaming data comprising an advertising-sponsored content portion and an associated obligatory advertising portion;

wherein the obligatory advertising portion is transmitted to the data storage medium at a first transmission rate and the advertising-sponsored content portion is transmitted to the data storage medium at a second transmission rate slower than the first transmission rate until after substantially all of the obligatory advertising portion is played by the multimedia player; and

sending a message to the data storage medium to mark the advertising-sponsored content portion as expired upon receipt of a navigation message requesting an unauthorized skip.

7. The method according to claim 6 wherein the second transmission rate is sufficiently slow to permit the obligatory advertising portion to be entirely transmitted to the data storage medium and entirely played by the multimedia player prior to the entire advertising-sponsored content portion being transmitted to the data storage medium.

8. The method according to claim 6, wherein the transmission rate of the advertising-sponsored content portion changes in response to a play control mode of the multimedia player.

9. The method according to claim 8, wherein the play control mode of the multimedia player comprises a stop mode and/or a pause mode, the transmission of the advertising-sponsored content being stopped or paused when the play control mode of the multimedia player is determined to be in the stop mode and/or pause mode.

10. The method according to claim 6, wherein the second transmission rate increases when the obligatory advertising portion is determined to have been entirely played by the multimedia player.

11. The method according to claim 6, wherein the obligatory advertising portion is transmitted to the data storage medium from a first server and the advertising-sponsored content is transmitted to the data storage medium from a second server.

12. An apparatus comprising:

a server computing device configured to transmit streaming data to a data storage medium that is accessible to a device having a multimedia player, the streaming data comprising advertising-sponsored content and obligatory advertising, the obligatory advertising being transmitted to the data storage medium prior to transmission of the advertising-sponsored content;

the server computing device configured to transmit the advertising-sponsored content to the data storage medium after determining that substantially all of the obligatory advertising portion has been played in the multimedia player; and

the server computing device configured to send a message to the data storage medium to mark the advertising-sponsored content portion as expired upon receipt of a navigation message requesting an unauthorized skip.

31

13. The apparatus of claim 12 wherein the server is configured to transmit the advertising-sponsored content to the data storage medium after determining that substantially all of the obligatory advertising has been played in the multimedia player and the server receives a play request from the multimedia player.

14. The apparatus of claim 12 wherein the server is configured to transmit the obligatory advertising at a first transmission rate and the advertising-sponsored content at a second transmission rate until after substantially all of the obligatory advertising is played by the multimedia player, wherein the second transmission rate is slower than the first transmission rate.

15. A method comprising:

transmitting streaming data to a data storage medium that is accessible to a device having a multimedia player, the streaming data comprising an advertising-sponsored content portion and an associated obligatory advertising portion, the obligatory advertising portion being first transmitted to the data storage medium; and

in response to a determination that the obligatory advertising portion has been played in the multimedia player, transmitting the advertising-sponsored content portion to the data storage medium;

maintaining a first time variable that assumes a value corresponding to a moment when a navigation message is received from the multimedia player;

maintaining a second time variable reflecting a portion of the streaming data that a user is attempting to play and is incremented, decremented, and paused in response to navigation messages received from the multimedia player; and

maintaining a maximum value time variable during playing of the advertising-sponsored content portion, the maximum value time variable assuming the maximum value reached by the second time variable.

16. The method of claim 15, wherein the obligatory advertising portion is transmitted to the data storage medium by a first server and the advertising-sponsored content is transmitted to the data storage medium by a second server.

17. The method according to claim 15, wherein the data storage medium is a cache.

18. The method according to claim 15, wherein the streaming data is transmitted to the data storage medium in packets using a version of the Real-time Transport Protocol (RTP) protocol.

19. The method of claim 15 wherein the advertising-sponsored content portion is transmitted to the data storage medium in response to receiving a play request from the multimedia player.

20. An apparatus comprising:

a server computing device configured to transmit streaming data to a data storage medium that is accessible to a device having a multimedia player, the streaming data comprising advertising-sponsored content and obligatory advertising, the obligatory advertising being transmitted to the data storage medium prior to transmission of the advertising-sponsored content;

the server computing device configured to transmit the advertising-sponsored content to the data storage medium after determining that substantially all of the obligatory advertising portion has been played in the multimedia player;

the server computing device configured to maintain a first time variable that assumes a value corresponding to a moment when a navigation message is received from the multimedia player and a second time variable reflecting

32

a portion of the streaming data that a user is attempting to play and is incremented, decremented, and paused in response to navigation messages received from the multimedia player; and

the server computing device is configured to maintain a maximum value time variable during playing of the advertising-sponsored content portion, the maximum value time variable assuming the maximum value reached by the second time variable.

21. The apparatus of claim 20 wherein the server is configured to transmit the advertising-sponsored content to the data storage medium after determining that substantially all of the obligatory advertising has been played in the multimedia player and the server receives a play request from the multimedia player.

22. The apparatus of claim 20 wherein the server is configured to transmit the obligatory advertising at a first transmission rate and the advertising-sponsored content at a second transmission rate until after substantially all of the obligatory advertising is played by the multimedia player, wherein the second transmission rate is slower than the first transmission rate.

23. A method comprising:

transmitting streaming data to a data storage medium that is accessible to a device having a multimedia player, the streaming data comprising an advertising-sponsored content portion and an associated obligatory advertising portion;

wherein the obligatory advertising portion is transmitted to the data storage medium at a first transmission rate and the advertising-sponsored content portion is transmitted to the data storage medium at a second transmission rate slower than the first transmission rate until after substantially all of the obligatory advertising portion is played by the multimedia player;

maintaining a first time variable that assumes a value corresponding to a moment when a navigation message is received from the multimedia player;

maintaining a second time variable reflecting a portion of the streaming data that a user is attempting to play and is incremented, decremented, and paused in response to navigation messages received from the multimedia player; and

maintaining a maximum value time variable during playing of the advertising-sponsored content portion, the maximum value time variable assuming the maximum value reached by the second time variable.

24. The method according to claim 23 wherein the second transmission rate is sufficiently slow to permit the obligatory advertising portion to be entirely transmitted to the data storage medium and entirely played by the multimedia player prior to the entire advertising-sponsored content portion being transmitted to the data storage medium.

25. The method according to claim 23, wherein the transmission rate of the advertising-sponsored content portion changes in response to a play control mode of the multimedia player.

26. The method according to claim 25, wherein the play control mode of the multimedia player comprises a stop mode and/or a pause mode, the transmission of the advertising-sponsored content being stopped or paused when the play control mode of the multimedia player is determined to be in the stop mode and/or pause mode.

27. The method according to claim 23, wherein the second transmission rate increases when the obligatory advertising portion is determined to have been entirely played by the multimedia player.

28. The method according to claim 23, wherein the obligatory advertising portion is transmitted to the data storage medium from a first server and the advertising-sponsored content is transmitted to the data storage medium from a second server.

5

* * * * *