



US009270734B2

(12) **United States Patent**
Zhang et al.

(10) **Patent No.:** **US 9,270,734 B2**
(45) **Date of Patent:** **Feb. 23, 2016**

(54) **DOWNLOAD METHOD AND SYSTEM BASED ON MANAGEMENT DATA INPUT/OUTPUT INTERFACE**

(75) Inventors: **Yun Zhang**, Shenzhen (CN); **Yu Fang**, Shenzhen (CN)

(73) Assignee: **ZTE CORPORATION** (CN)

(*) Notice: Subject to any disclaimer, the term of this patent is extended or adjusted under 35 U.S.C. 154(b) by 199 days.

(21) Appl. No.: **13/696,323**

(22) PCT Filed: **Dec. 10, 2010**

(86) PCT No.: **PCT/CN2010/079647**

§ 371 (c)(1),
(2), (4) Date: **Nov. 6, 2012**

(87) PCT Pub. No.: **WO2011/137648**

PCT Pub. Date: **Nov. 10, 2011**

(65) **Prior Publication Data**

US 2013/0058347 A1 Mar. 7, 2013

(30) **Foreign Application Priority Data**

May 6, 2010 (CN) 2010 1 0173383

(51) **Int. Cl.**

H04L 12/28 (2006.01)

H04L 29/08 (2006.01)

H04L 29/06 (2006.01)

(52) **U.S. Cl.**

CPC **H04L 67/06** (2013.01); **H04L 69/22** (2013.01)

(58) **Field of Classification Search**

CPC H04L 29/10; H04L 29/02; H04L 29/04; H04L 29/08; H04L 2029/02; H04L 2029/06

USPC 370/394, 465-476; 709/208-211, 709/230-237, 253

See application file for complete search history.

(56) **References Cited**

U.S. PATENT DOCUMENTS

5,946,462 A * 8/1999 Rangan et al. 714/49
6,859,825 B1 * 2/2005 Williams 709/220

(Continued)

FOREIGN PATENT DOCUMENTS

CN 101162440 A 4/2008
CN 101197770 A 6/2008

(Continued)

OTHER PUBLICATIONS

IEEE Standard 802.3ae-2002 (Amendment to IEEE Std 802.3-2002), Aug. 30, 2002, Institute of Electrical and Electronics Engineers (IEEE), Section 45, pp. 161-162 and 225-229.*

(Continued)

Primary Examiner — Timothy J Weidner

Assistant Examiner — Jana Blust

(74) *Attorney, Agent, or Firm* — Cantor Colburn LLP

(57) **ABSTRACT**

The disclosure provides a download method and system based on a Management Data Input/Output (MDIO) interface, wherein the download method based on the MDIO interface comprises: a master device informing a slave device of using the MDIO interface to start downloading data packets in batches; the master device transmitting data packets in batches to the slave device by using an MDIO frame, wherein the MDIO frame comprises: a data packet address field and/or a data packet serial number field, wherein the data packet address field is used to indicate a relative address of one data packet in the slave device, and the data packet serial number field is used to indicate a location of said one data packet in multiple data packets; the slave device judging that a received data packet is a last data packet of a current batch transmission from the master device, and finishing a current batch download. The invention enables the master device and the slave device to perform the batch data download effectively, and solves the problem in the related art that large batch data transmission cannot be performed for download based on the MDIO interface.

18 Claims, 5 Drawing Sheets

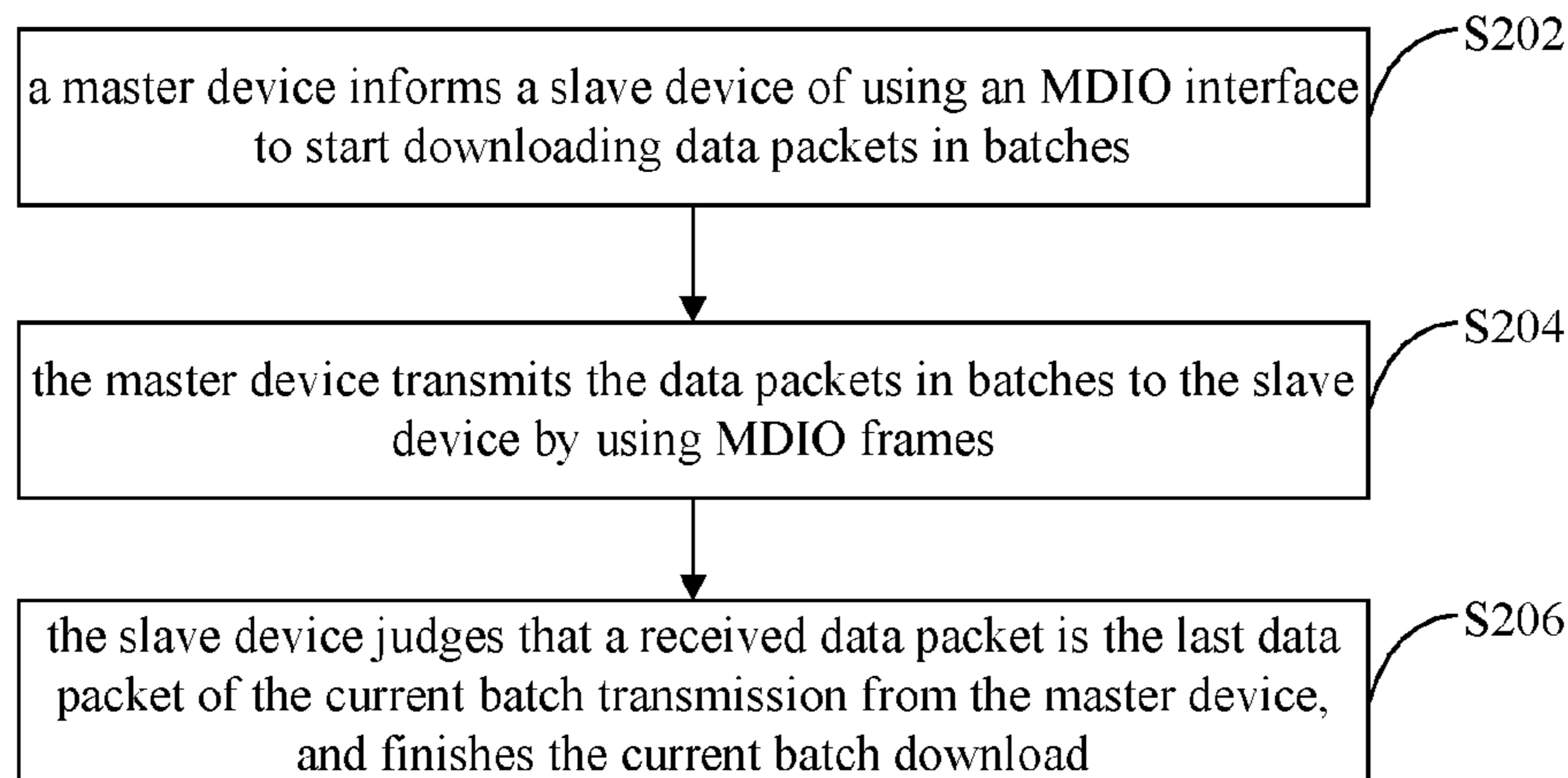

(56)

References Cited

U.S. PATENT DOCUMENTS

6,975,637	B1 *	12/2005	Lenell	370/412
7,287,208	B2 *	10/2007	Dybsetter et al.	714/758
7,376,780	B2 *	5/2008	Herman	710/315
8,667,194	B2 *	3/2014	Dybsetter et al.	710/110
2003/0200374	A1 *	10/2003	Moriwaki et al.	710/305
2005/0128962	A1 *	6/2005	Dybsetter et al.	370/278
2005/0132247	A1 *	6/2005	Dybsetter et al.	714/1
2007/0101043	A1	5/2007	Herman	
2008/0159288	A1 *	7/2008	Nagarajan et al.	370/392
2010/0027565	A1 *	2/2010	Gupta et al.	370/475
2010/0169600	A1 *	7/2010	Inoue	711/163

FOREIGN PATENT DOCUMENTS

CN	101437179	A	5/2009
CN	101569146	A	10/2009

JP	2008118349	A	5/2008
WO	2010021120	A1	2/2010

OTHER PUBLICATIONS

IEEE Standards 802.3ae-2002, IEEE Standard for Information technology—Telecommunications and information exchange between systems—Local and metropolitan area networks—Specific requirements, Part 3, Amendment 1: MAC Parameters, Physical Layers, and Management Parameters for 10Gb/s Operations, IEEE Computer Society, Aug. 30, 2012, pp. 224-228.*

International Search Report; International Application No. PCT/CN2010/079647; International Filing Date Dec. 10, 2010; Mail date Mar. 24, 2011.

Extended European Search Report for corresponding application EP10851017; Report Dated Jan. 7, 2015.

* cited by examiner

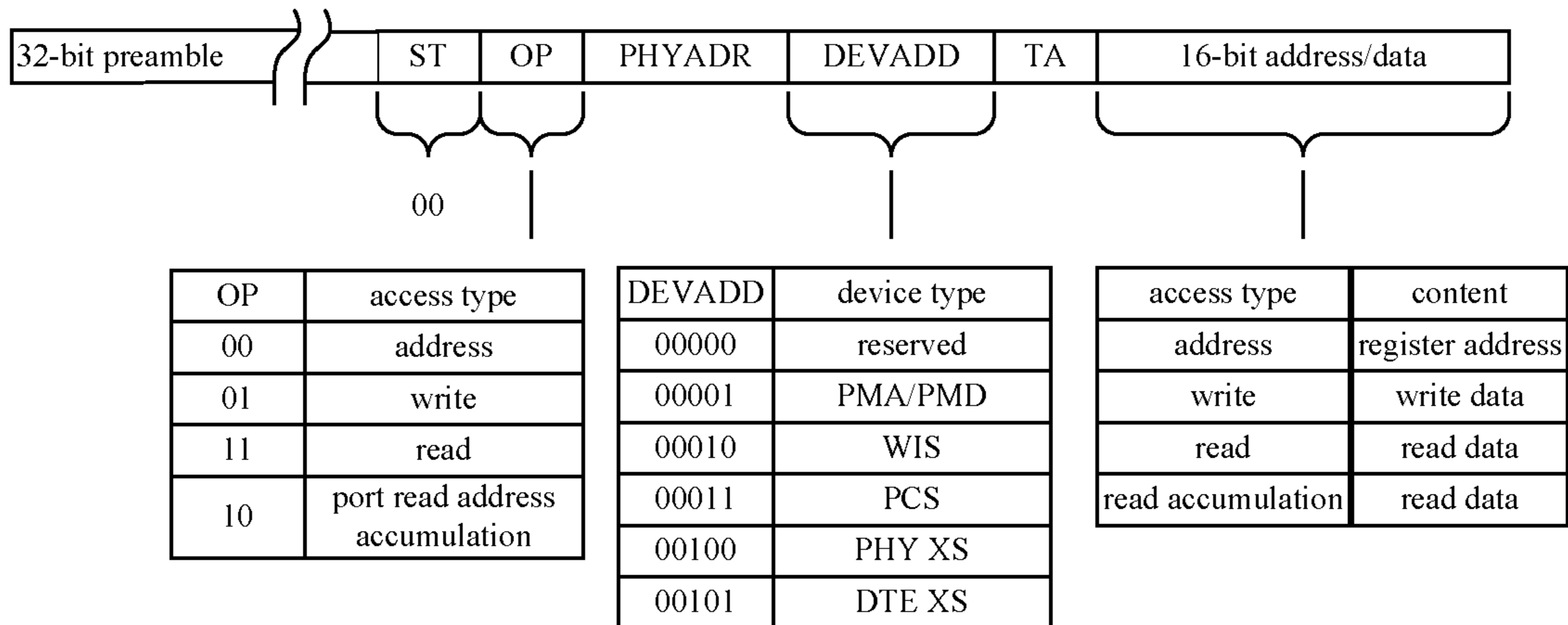

Fig. 1

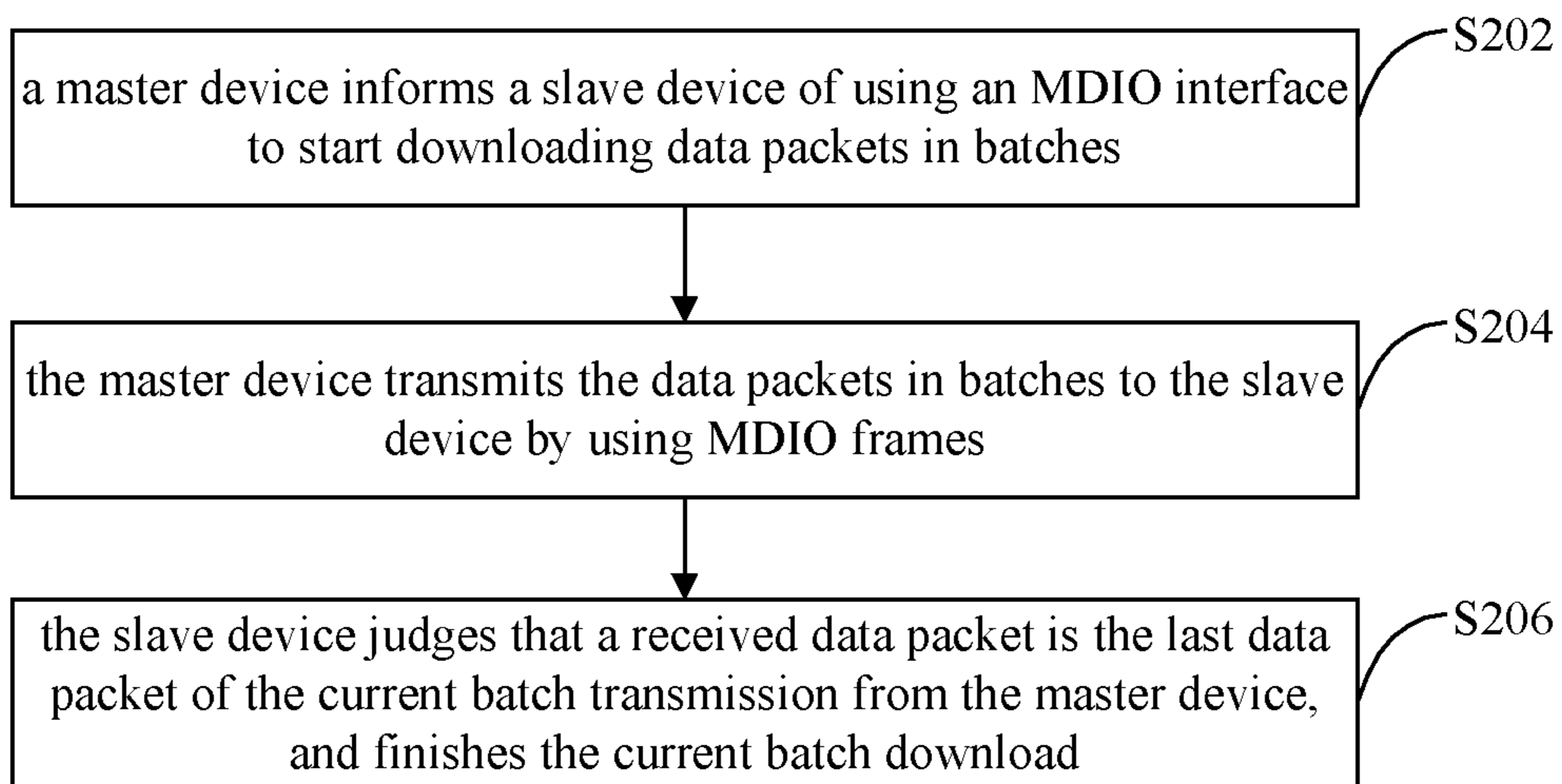

Fig. 2

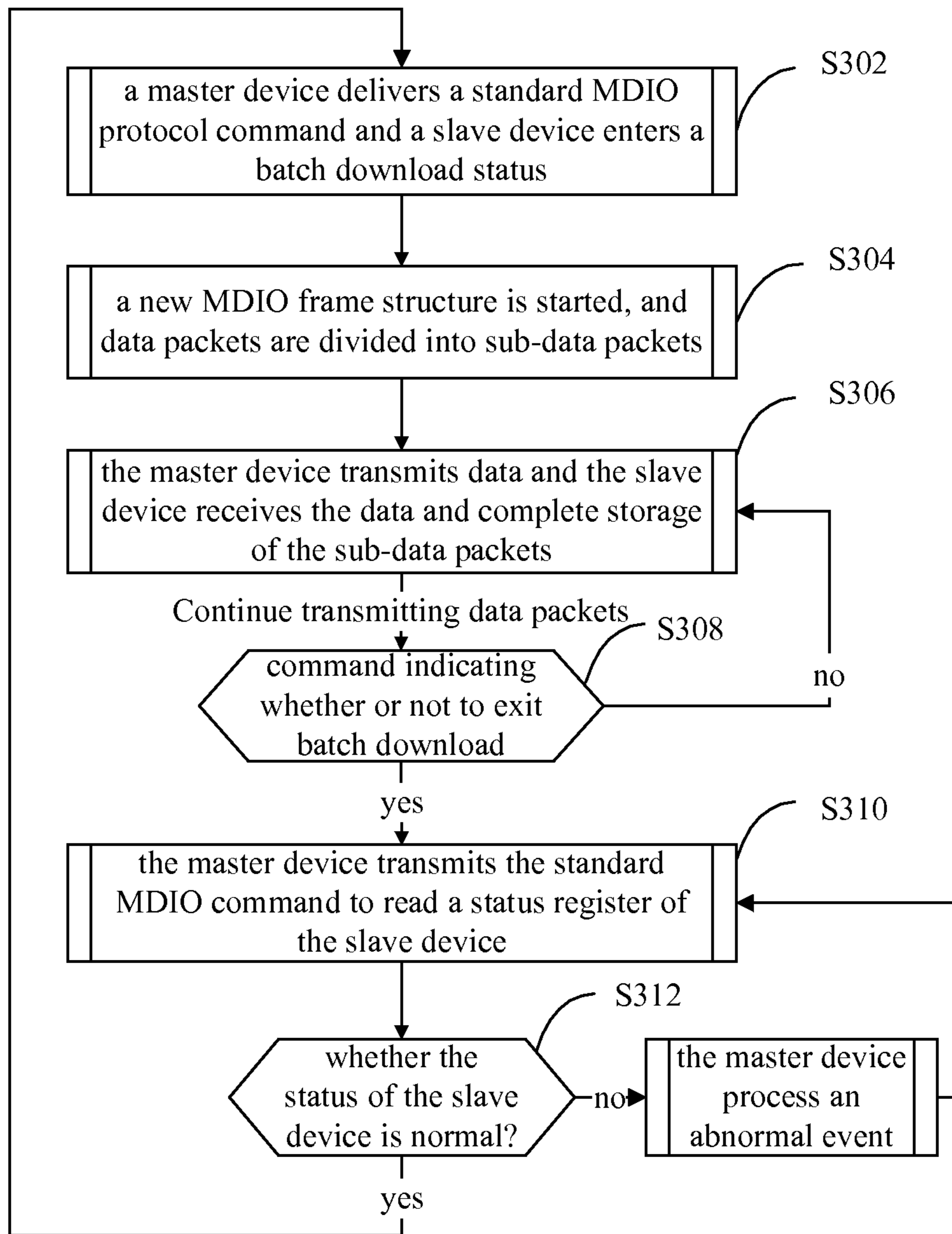

Fig. 3

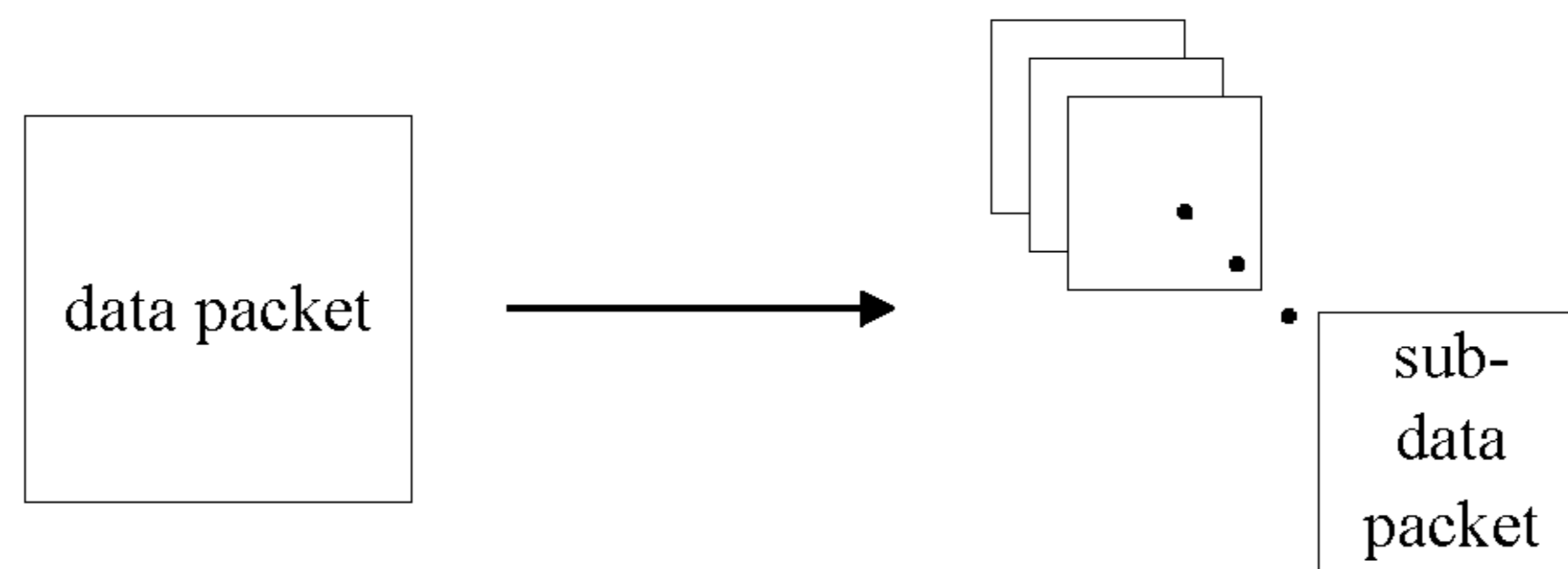
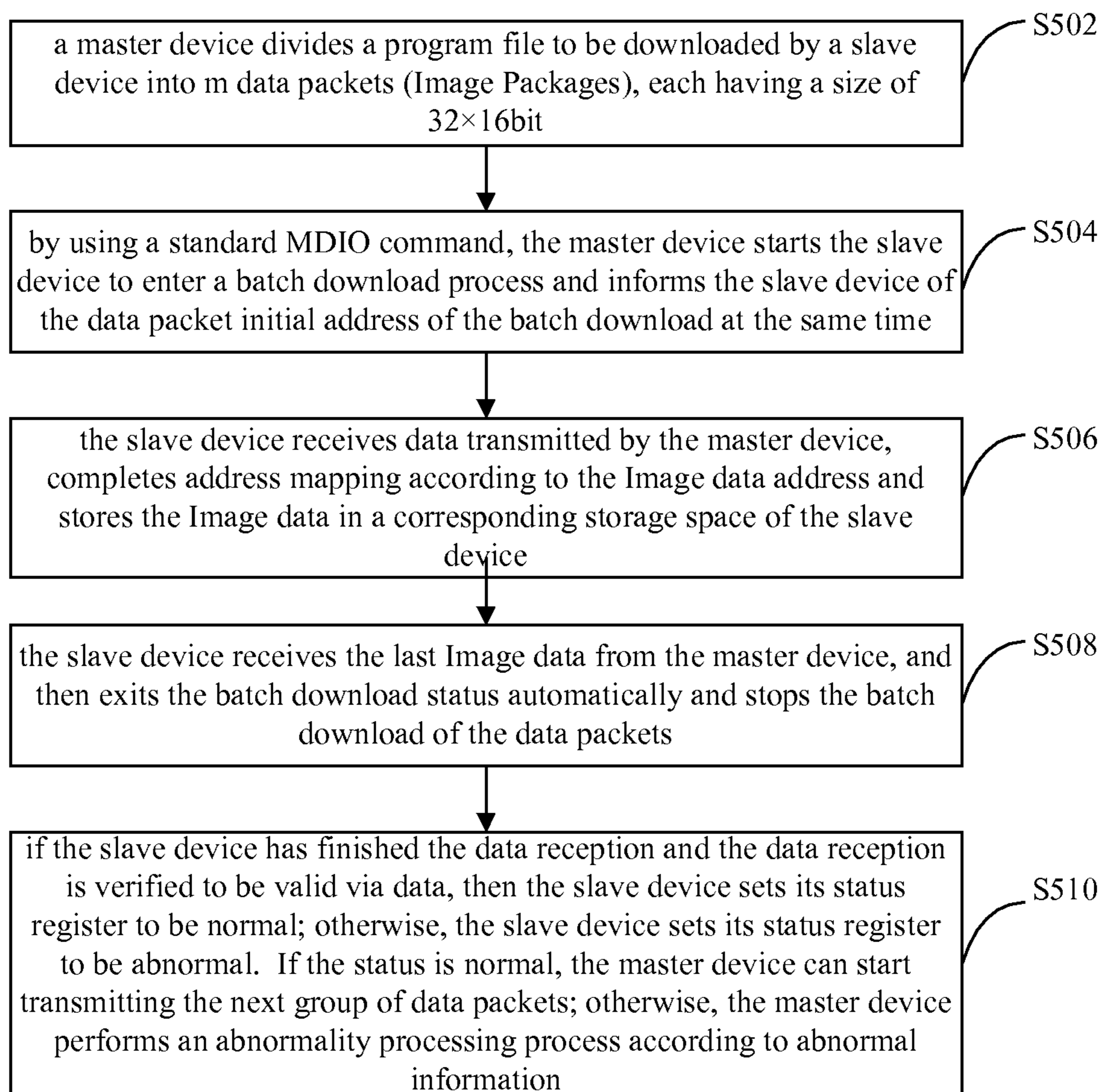
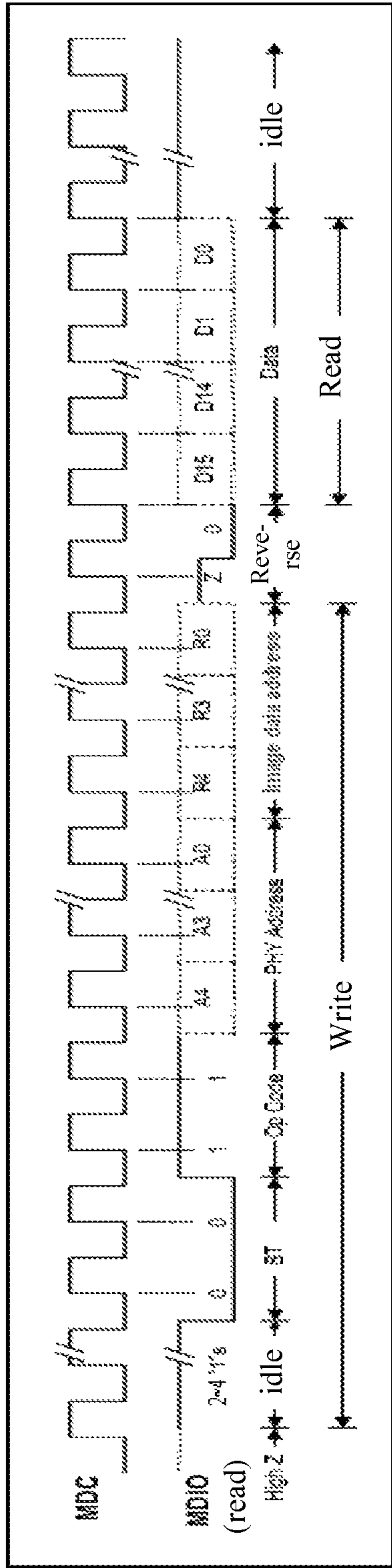

Fig. 4

**Fig. 5**

read frame structure



write frame structure

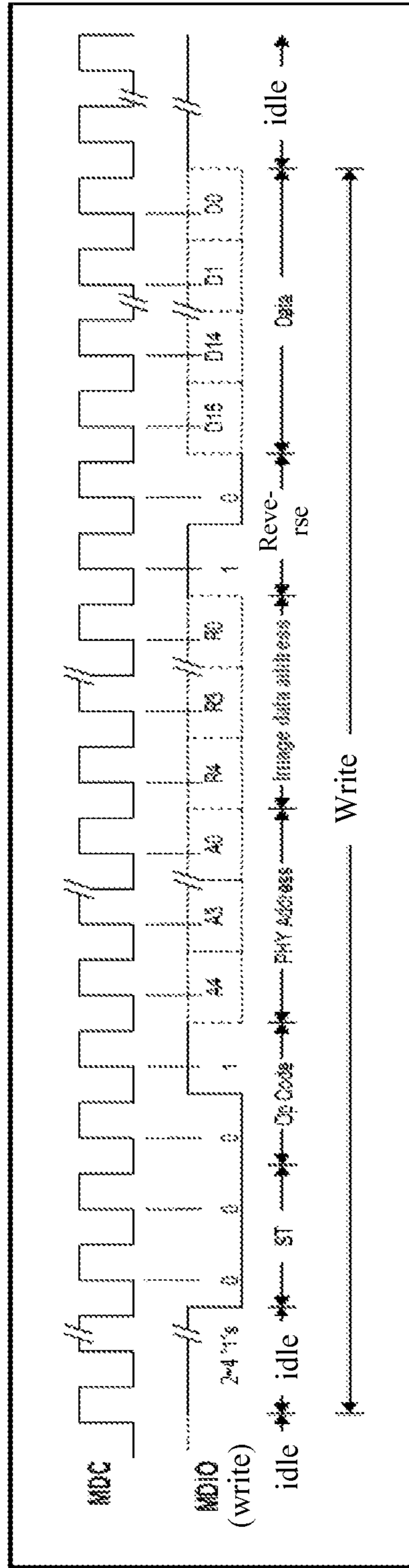

Fig. 6

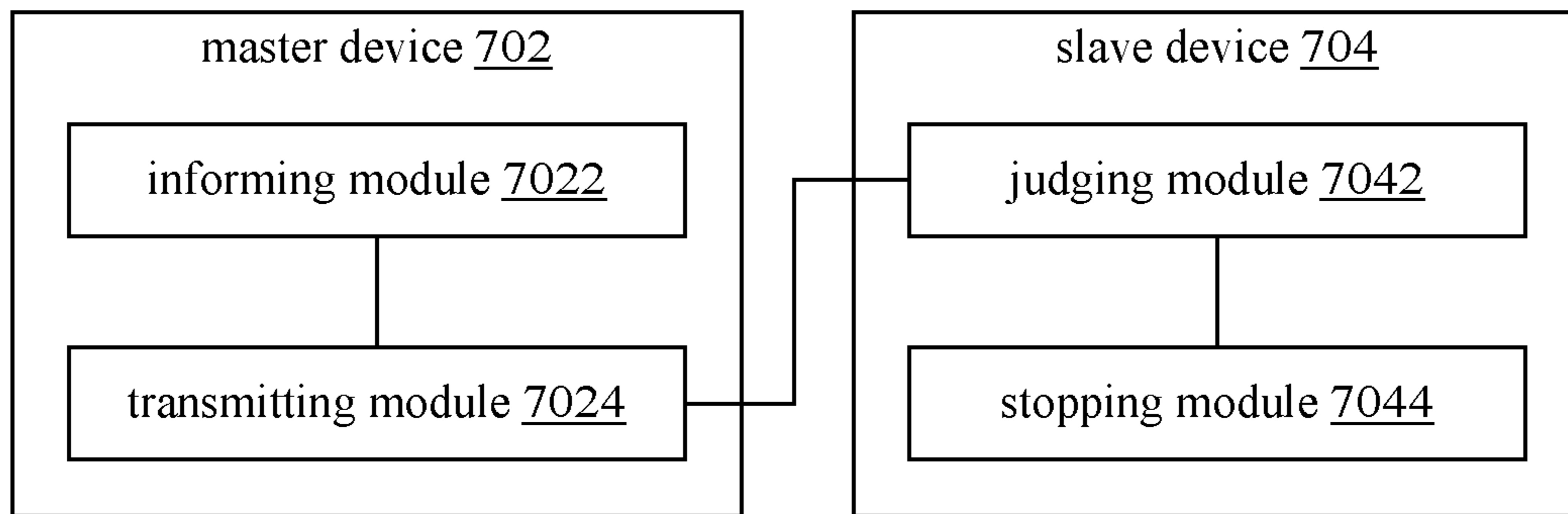

Fig. 7

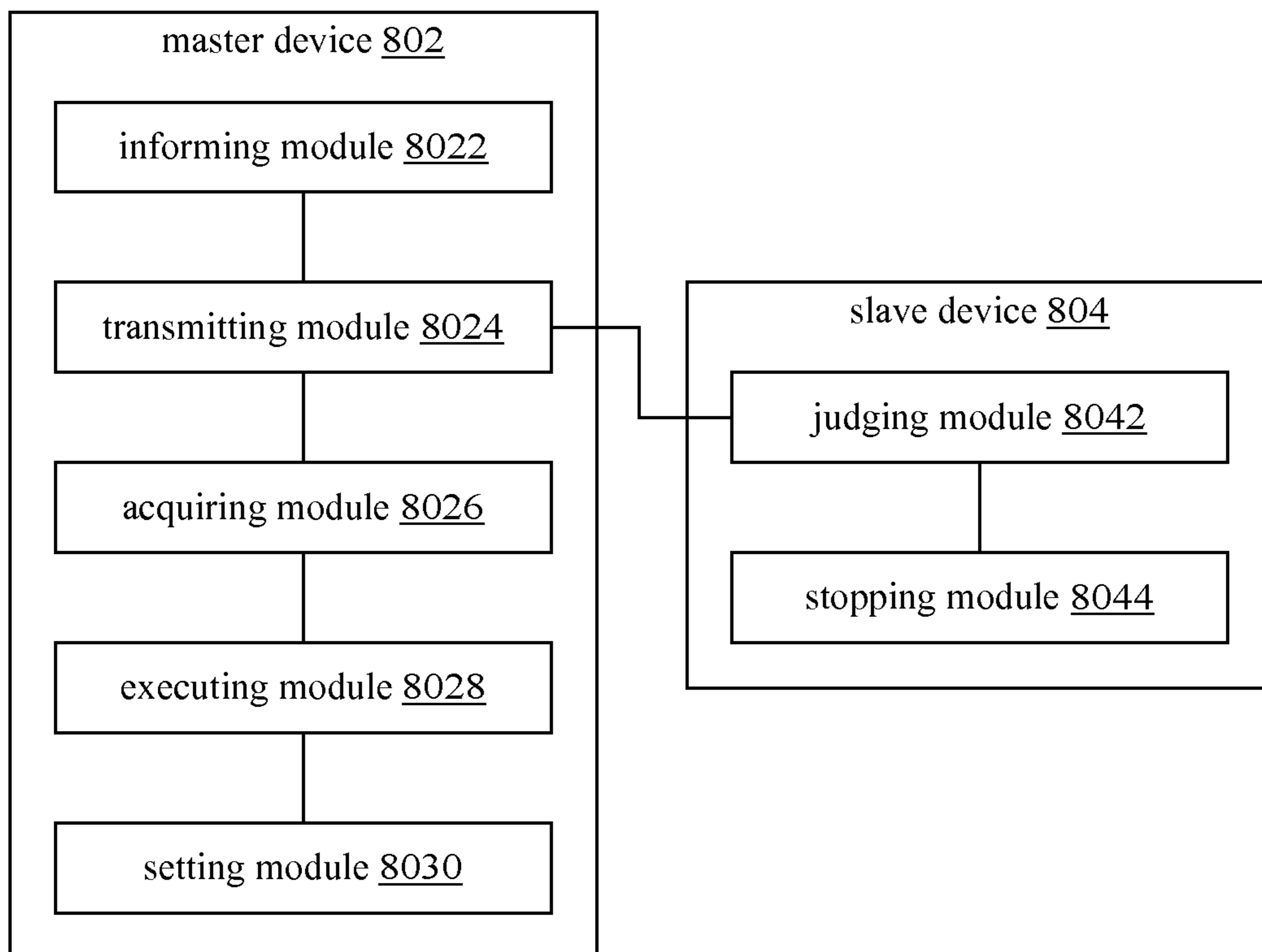

Fig. 8

1

**DOWNLOAD METHOD AND SYSTEM BASED
ON MANAGEMENT DATA INPUT/OUTPUT
INTERFACE**

FIELD OF THE INVENTION

The disclosure relates to the communication field, and more particularly to a download method and system based on a Management Data Input/Output (MDIO) interface.

BACKGROUND OF THE INVENTION

For Gigabit Ethernet, a serial communication bus is called MDIO. The bus is defined by terms of Ethernet standards Institute of Electrical and Electronics Engineers (IEEE) 802.3 of the IEEE. The MDIO is a simple double-wire serial interface that connects a management device (e.g. a Media Access Control (MAC) controller or a microprocessor) with a transceiver (e.g. a multi-port Gigabit Ethernet transceiver or a 10 Gigabit Ethernet 10 Attachment Unit Interface (10 GbE XAUI) transceiver) with management functions, so that the management device can control the transceiver and collect status information from the transceiver.

With the development of optical transmission technologies and data services, transponders are widely applied. Functions and interfaces of 100G transponders and 100G C Form-factor Pluggable (CFP) transponders have been defined by relevant international standards, but definition for the online download function of optical modules is still absent. With the growing complexity of optical module functions and the increasing improvement on optical module performance, the online upgrading ability of optical module software is critical for system equipment manufacturers. Recently, mainstream optical module manufacturers have begun defining a set of Internet Access Point (IAP) protocols based on existing hardware interfaces. However, transmission of large batch data is not taken into consideration in the protocols. In addition, in 64 bits of a frame structure (as shown in FIG. 1) in an existing MDIO interface, there are only 16 bits of effective data information which takes 25% of the whole frame length. It means that, the time for transmitting a 1 MByte file is only 4 times as much as that for downloading the effective information only. Therefore, it is low in performance and efficiency to implement the IAP protocols by existing MDIO frame structures and communication mechanisms, the download time is long, and repeated download failures occur easily.

SUMMARY OF THE INVENTION

The disclosure provides a download method and system based on an MDIO interface to solve the problems that it is low in performance and efficiency to implement the IAP by existing MDIO frame structures and communication mechanisms, the download time is long and repeated download failures occur easily.

According to an aspect of the disclosure, a download method based on an MDIO interface is provided, comprising: a master device informing a slave device of using the MDIO interface to start downloading data packets in batches; the master device transmitting data packets in batches to the slave device by using an MDIO frame, wherein the MDIO frame comprises: a data packet address field and/or a data packet serial number field, wherein the data packet address field is used to indicate a relative address of one data packet in the slave device, and the data packet serial number field is used to indicate a location of said one data packet in multiple data packets; and the slave device judging that a received data

2

packet is a last data packet of a current batch transmission from the master device, and finishing a current batch download.

Preferably, the MDIO frame uses an idle field of a set number of bits to replace a preamble field.

Preferably, the step of the master device informing the slave device of using the MDIO interface to start downloading the data packets in batches comprises: the master device informing, through an MDIO protocol command, the slave device of using the MDIO interface to start downloading the data packets in batches, wherein the MDIO protocol command comprises download register information, wherein the download register information comprises serial numbers of the data packets transmitted in batches by the master device to the slave device; the step of the slave device judging that a received data packet is the last data packet in the data packets transmitted in batches by the master device comprises: the slave device judging according to a serial number that the received data packet is the last data packet in the data packets transmitted in batches by the master device.

Preferably, the step of the slave device judging that a received data packet is the last data packet of the current batch transmission from the master device comprises: the slave device receiving one MDIO frame transmitted by the master device, parsing out a data packet from the MDIO frame, and storing data of the data packet in the slave device according to an address indicated by the data packet address field or according to a serial number indicated by the data packet serial number field; and the slave device judging that the stored data packet is the last data packet of the current batch transmission from the master device.

Preferably, the download method based on the MDIO interface further comprises: during a process that the master device transmits the data packets in batches to the slave device by using the MDIO frame, the master device reading download status register information of the slave device through an MDIO protocol command; the master device judging, according to the download status register information, whether the slave device receives a previous group of data packets normally; if so, starting downloading a new group of data packets in batches; otherwise, forcing the slave device to stop a batch download.

Preferably, the download method based on the MDIO interface further comprises: during a process that the master device transmits the data packets in batches to the slave device by using the MDIO frame, if an abnormality of the master device or the slave device occurs and a batch download of the data packets is not stopped, the master device setting a value of the data packet address field or the data packet serial number field of the MDIO frame to indicate the slave device to stop the batch download of the data packets.

Preferably, before the step of the master device informing the slave device of using the MDIO interface to start downloading the data packets in batches, the method further comprises: the master device setting a length of the MDIO frame according to hardware conditions of the slave device.

According to another aspect of the disclosure, a download system based on an MDIO interface is provided, comprising: a master device and a slave device, wherein the master device comprises: an informing module, configured to inform the slave device of using the MDIO interface to start downloading data packets in batches; and a transmitting module, configured to transmit the data packets in batches to the slave device by using an MDIO frame, wherein the MDIO frame comprises: a data packet address field and/or a data packet serial number field, wherein the data packet address field is used to indicate a relative address of one data packet in the

slave device, and the data packet serial number field is used to indicate a location of said one data packet in multiple data packets; the slave device comprises: a judging module, configured to judge that a received data packet is a last data packet of a current batch transmission from the master device; and a stopping module, configured to stop a current batch download.

Preferably, the MDIO frame uses an idle field of a set number of bits to replace a preamble field.

Preferably, the informing module of the master device comprises: an MDIO command module, configured to: inform, through an MDIO protocol command, the slave device of using the MDIO interface to start downloading the data packets in batches, wherein the MDIO protocol command comprises download register information, wherein the download register information comprises serial numbers of the data packets transmitted in batches by the master device to the slave device; the judging module of the slave device comprises: a command receiving module, configured to receive the MDIO protocol command and acquire the serial numbers; and a serial number judging module, configured to judge according to a serial number that a received data packet is the last data packet of the current batch transmission from the master device.

Preferably, the master device further comprises: an acquiring module, configured to: during a process of transmitting the data packets in batches to the slave device by using the MDIO frame, read download status register information of the slave device through an MDIO protocol command; and an executing module, configured to: judge, according to the download status register information, whether the slave device receives a previous group of data packets normally; if so, start downloading a new group of data packets in batches; otherwise, force the slave device to stop a batch download.

Preferably, the master device further comprises: a setting module, configured to: during a process of transmitting the data packets in batches to the slave device by using the MDIO frame, if an abnormality of the master device or the slave device occurs and a batch download of the data packets is not stopped, set a value of the data packet address field or the data packet serial number field of the MDIO frame to indicate the slave device to stop the batch download of the data packets.

By using a new communication handshake mechanism, the disclosure enables the master device and the slave device to perform the batch data download effectively, thus solving the problem in related technologies that large batch data transmission cannot be performed for download based on the MDIO interface. In addition, the disclosure applies a new MDIO frame structure to adapt the MDIO frame to batch data download requirements and improve data download efficiency.

BRIEF DESCRIPTION OF THE DRAWINGS

Drawings, provided for further understanding of the present invention and forming a part of the specification, are used to explain the present invention together with embodiments of the present invention rather than to limit the present invention, wherein:

FIG. 1 is a schematic diagram illustrating an MDIO frame structure in a related technology;

FIG. 2 is a flowchart of a download method based on an MDIO interface according to an embodiment of the disclosure;

FIG. 3 is a flowchart of another download method based on an MDIO interface according to an embodiment of the disclosure;

FIG. 4 is a schematic diagram illustrating grouping of data packets to be downloaded in a batch download process based on an MDIO interface according to an embodiment of the disclosure;

FIG. 5 is a flowchart illustrating a third download method based on an MDIO interface according to an embodiment of the disclosure;

FIG. 6 is a schematic diagram illustrating an MDIO frame structure according to an embodiment of the disclosure;

FIG. 7 is a structural block diagram illustrating a download system based on an MDIO interface according to an embodiment of the disclosure; and

FIG. 8 is a structural block diagram illustrating another download system based on an MDIO interface according to an embodiment of the disclosure.

DETAILED DESCRIPTION OF THE EMBODIMENTS

The disclosure will be described in details below with reference to the accompanying drawings and in combination with the embodiments. It should be noted that, if there is no conflict, the embodiments of the application and the characteristics in the embodiments can be combined with one another.

FIG. 2 shows a flowchart of a download method based on an MDIO interface according to an embodiment of the disclosure, and the method comprises the following steps.

Step 202: a master device informs a slave device of using the MDIO interface to start downloading data packets in batches.

For example, when learning that the slave device needs to download data in batches, the master device informs the slave device of using the MDIO interface to enter a batch download status to start downloading the data packets in batches. In the present step, preferably, by using a standard MDIO protocol command, the master device can inform the slave device of starting downloading the data packets in batches, wherein the MDIO protocol command comprises information for starting the slave device to enter a batch download process and can further comprise data packet download register information, such as a slave device MDIO address, and an address or a serial number of a data packet to be transmitted etc.

Step 204: the master device transmits the data packets in batches to the slave device by using an MDIO frame;

wherein the MDIO frame comprises: a data packet address field used to indicate a relative address of one data packet in the slave device and/or a data packet serial number field used to indicate a location of one data packet in multiple data packets.

The data packet address field and/or the data packet serial number field are/is set in the MDIO frame to transmit data in batches effectively, thus meeting requirements of downloading the data packets in batches by the master device and the slave device.

Step 206: the slave device judges that a received data packet is the last data packet of the current batch transmission from the master device, and finishes the current batch download.

The slave device receives the data packets transmitted by the master device. When all data packets are transmitted to the slave device normally, the slave device judges that a data packet is the last data packet of the current batch download of the data packets. At this time, the slave device exits the batch download status automatically, or the master device initiates

that the master device and the slave device exit the batch download status simultaneously, and the batch download is finished.

In related technologies, the transmission of large batch of data is not considered when IAP protocols are implemented, therefore, MDIO frame structures and communication mechanisms for implementing the IAP protocols are low in performance and efficiency, the download time is long, and repeated download failures occur easily. The present embodiment applies a new handshake mechanism adapted to batch data download and an MDIO frame structure adapted to the mechanism, thus effectively solving the problem of batch data download and improving the data download efficiency.

FIG. 3 shows a flowchart of another download method based on an MDIO interface according to an embodiment of the disclosure, and the method comprises the following steps.

Step 302: a master device informs, through a standard MDIO protocol command, a slave device of entering a batch download status to start downloading data packets in batches.

Step 304: by using the MDIO frame structure, the master device transmits the data packets in batches to the slave device in a batch packaging method.

In the method, the MDIO frame comprises: a data packet address field used to indicate the relative address of one data packet in the slave device and/or a data packet serial number field used to indicate the location of one data packet in multiple data packets. The difference between the MDIO frame in the present embodiment and an existing standard MDIO frame further comprises that: a preamble field of the existing standard MDIO frame is removed and replaced by an idle field of a set number of bits, e.g. an idle field of 2 to 4 bits. The idle field is used to indicate the MDIO frame as a new MDIO frame, wherein the number of bits of the idle field can be set properly by those skilled in the art according to actual conditions. The size of the MDIO frame can be defined according to hardware conditions of the slave device, e.g. if the MDIO interface of the slave device is provided with ample buffer, the MDIO standard frame length 64 bit does not need to be satisfied.

In the present step, the master device can apply the method as shown in FIG. 4 to transmit the data packets to the slave device according to the batch packaging method. The size of a data packet can be determined comprehensively according to the download efficiency and the processing difficulty of handling abnormal events.

Step 306: the slave device finishes download register address mapping, and receives and stores the data packets transmitted by the master device.

The slave device acquires the data packet address field and/or the data packet serial number field from the MDIO frame, determines the address of a currently-transmitted data packet in the slave device, receives the data packet transmitted by the master device and stores the data packet in the corresponding address.

Once entering the batch download status, the slave device will no longer respond to the standard MDIO command transmitted by the master device.

Step 308: when receiving the last data packet transmitted by the master device, the slave device exits the batch download status automatically, or the master device initiates that the master device and the slave device exit the batch download status simultaneously, and the batch data packet download is finished.

For example, according to the serial numbers of the data packets transmitted in batches by the master device to the slave device in the download register information of the MDIO protocol command transmitted by the master device,

the slave device, when receiving a data packet transmitted by the master device, can judge whether the data packet is the last data packet of the current batch download according to a serial number. The process is implemented easily, thus saving system design cost.

Step 310: the master device communicates with the slave device through the standard MDIO protocol command and reads the download status of the slave device to determine whether the previous group of data packets are received normally.

In the present step, the master device can read download status register information of the slave device to acquire the download status of the slave device therein.

Step 312: if the download status of the slave device is normal, then a download process of a new group of data packets can be started directly; otherwise, the master device judges that an abnormality occurs, and starts a corresponding processing process to solve the abnormality directly.

In the case that any abnormality occurs during the download process, the master device can transmit a special command to force the slave device to exit the batch download status.

FIG. 5 shows a flowchart illustrating a third download method based on an MDIO interface according to an embodiment of the disclosure, and the method comprises the following steps.

Step 502: a master device divides a program file to be downloaded by a slave device into m data packets (Image Packages), wherein the size of each data packet is 32×16 bit, 32 corresponds to the number of sub-data packets (image data) into which the data packet is divided continuously, and 16 bit corresponds to the register size of a commonly-used MDIO interface of the slave device.

When a batch download process is started, the size of a sub-data packet which is the fundamental unit for data transmission is generally limited by bottom layer device conditions of the master device and the slave device, so that the MDIO frame structure and the communication handshake mechanism can adapt to data transmission among multiple kinds of devices. There are flexible and varied MDIO frame structures and communication handshake mechanisms.

Step 504: by using a standard MDIO command, the master device starts the slave device to enter a batch download process and informs the slave device of the data packet initial address (relative address in the slave device) of the batch download at the same time. Table 1 shows implementation of the download function defined by the MDIO interface of the master device, where A0F8 is the slave device MDIO address which needs to be written to start the download, the written data Image Package SerialNo represents the relative address of the data packet (Image Package) which will be written in the slave device by the master device. The MDIO command comprises the download register information so that the slave device can acquire the storage address of the data packet from the MDIO command directly.

TABLE 1

MDIO data packet Download Register Information						
Address	Size	Access type	Bit	Register name	Description	Integral value
A0F8	2	RW	15~0	Image Package SerialNo	Image Package SerialNo	0

In the present step, a redefined batch download MDIO frame structure is as shown in FIG. 6. The MDIO frame removes the preamble of a standard MDIO frame and replaces it by a set number (e.g. 2 to 4) of idle bits. The “Device Type” field in the standard MDIO frame is changed into an Image data address field (relative address of the sub-data packet in the slave device) or an Image data serialNo field (sub-data packet serial number). In the embodiment, the “Device Type” field in the standard MDIO frame is changed into the Image data address field (the sub-data packet address), wherein the range of the address is 0 to 31. The master device starts to deliver sub-data packets to the slave device according to the new MDIO frame structure.

Step 506: the slave device receives data transmitted by the master device, completes address mapping according to the Image data address and stores the Image data in a corresponding storage space of the slave device.

Step 508: the slave device receives the last Image data from the master device, i.e. Image data address=31, then exits the batch download status automatically and stops the batch data packet download.

Step 510: if the slave device has finished the data reception and the data reception is verified to be valid via data, the slave device sets its status register to be normal; otherwise, the slave device sets its status register to be abnormal. The master device reads status register information of the slave device through a standard MDIO command. The status register information is as shown in Table 2, where A0F2 is the register address of the slave device MDIO and “Download Status” represents the download status of the status register. If the status is normal, the master device can start transmission of the next group of data packets; otherwise, an abnormality processing process is performed according to abnormal information.

TABLE 2

MDIO Download Status Register Information						
Address	Size	Access type	Bit	Register name	Description	Integral value
A0F2	2	RO	15~11	Download Status	Download status definition	0
			10~8	Upload Status	Upload status definition	0
			7~0	Reserved		0

Particularly, if either the master device or the slave device is abnormal during the download process, but the slave device has not exited the batch download status after the abnormality is recovered, then the master device can write a non-address value in the last Image data address directly to force the slave device to exit the batch download status.

By judging whether the download status of the slave device is normal, a problem arising in the download process of the data packets can be discovered in time and solved correspondingly, thus avoiding repeated transmission of a large amount of data.

FIG. 7 shows a structural block diagram illustrating a download system based on an MDIO interface according to an embodiment of the disclosure. The system comprises: a master device 702 and a slave device 704.

The master device 702 comprises: an informing module 7022, configured to inform the slave device 704 of using the MDIO interface to start downloading data packets in batches; a transmitting module 7024, configured to transmit the data

packets in batches to the slave device 704 by using an MDIO frame, wherein the MDIO frame comprises: a data packet address field and/or a data packet serial number field, wherein the data packet address field is used to indicate the relative address of one data packet in the slave device 704, and the data packet serial number field is used to indicate the location of one data packet in multiple data packets.

The slave device 704 comprises: a judging module 7042, configured to judge that a received data packet is the last data packet of the current batch transmission from the master device 702; a stopping module 7044, configured to stop the current batch download.

For example, when the master device and the slave device start the batch download of the data packets, the informing module 7022 of the master device 702 firstly informs the slave device 704 of using the MDIO interface to start downloading the data packets in batches. The transmitting module 7024 of the master device 702 transmits the data packets in batches to the slave device 704 by using the MDIO frame, wherein the MDIO frame comprises: a data packet address field used to indicate the relative address of one data packet in the slave device 704 and/or a data packet serial number field used to indicate the location of one data packet in multiple data packets. The slave device 704 receives the data packets transmitted by the master device 702. The judging module 7042 judges that a received data packet is the last data packet of the current batch transmission from the master device 702, then the stopping module 7044 stops the current batch download.

FIG. 8 shows a structural block diagram illustrating another download system based on an MDIO interface according to an embodiment of the disclosure. The system comprises: a master device 802 and a slave device 804.

The master device 802 comprises: an informing module 8022, configured to inform the slave device 804 of using the MDIO interface to start downloading data packets in batches; a transmitting module 8024, configured to transmit the data packets in batches to the slave device 804 by using an MDIO frame, wherein the MDIO frame comprises: a data packet address field and/or a data packet serial number field, wherein the data packet address field is used to indicate the relative address of one data packet in the slave device 804, and the data packet serial number field is used to indicate the location of one data packet in multiple data packets.

Preferably, the MDIO frame uses an idle field of a set number of bits to replace a preamble field of the existing MDIO frame to indicate the beginning of a new MDIO frame.

Preferably, the master device 802 further comprises: an acquiring module 8026, configured to, during the process of transmitting the data packets in batches to the slave device 804 by using the MDIO frame, read download status register information of the slave device 804 through an MDIO protocol command; an executing module 8028 configured to, according to the download status register information, judge whether the slave device 804 receives the previous group of data packets normally; if so, start downloading a new group of batch data packets; otherwise, force the slave device 804 to stop the batch download.

Preferably, the master device 802 further comprises: a setting module 8030 configured to, during the process of transmitting the data packets in batches to the slave device 804 by using the MDIO frame, if an abnormality of the master device 802 or the slave device 804 occurs and the batch download of the data packets is not stopped, set the value of the data packet address field or the data packet serial number field of the MDIO frame to indicate the slave device 804 to stop the batch download of the data packets.

Preferably, the informing module **8022** of the master device **802** comprises: an MDIO command module configured to, through an MDIO protocol command, inform the slave device **804** of using the MDIO interface to start downloading the data packets in batches; wherein the MDIO protocol command comprises download register information, the download register information comprises serial numbers of the data packets transmitted by the master device **802** to the slave device **804**.

Preferably, the master device **802** further comprises: a frame length setting module configured to, before the informing module **8022** informs the slave device **804** of using the MDIO interface to download the data packets in batches, set a length of the MDIO frame according to hardware conditions of the slave device **804**.

The slave device **804** comprises: a judging module **8042** configured to judge that a received data packet is the last data packet of the current batch transmission from the master device **802**; a stopping module **8044**, configured to stop the current batch download.

Preferably, the judging module **8042** is configured to receive one MDIO frame transmitted by the master device **802**, parse out a data packet from the MDIO frame, store data of the data packet in the slave device **804** according to an address indicated by the data packet address field or according to a serial number indicated by the data packet serial number field, and judge that the stored data packet is the last data packet of the batch transmission from the master device **802**.

Preferably, the judging module **8042** comprises: a command receiving module configured to receive the MDIO protocol command and acquire serial numbers of the data packets transmitted in batches by the master device to the slave device; a serial number judging module configured to judge according to a serial number that a received data packet is the last data packet of the current batch transmission from the master device **802**. For example, by using the MDIO protocol command, the MDIO command module in the informing module **8022** of the master device **802** informs the slave device **804** of using the MDIO interface to start downloading the data packets in batches. The MDIO protocol command comprises the download register information of the serial numbers of the data packets transmitted in batches by the master device **802** to the slave device **804**. The transmitting module **8024** transmits the data packets in batches to the slave device **804** by using the MDIO frame, wherein the MDIO frame comprises: a data packet address field and/or a data packet serial number field, and uses an idle field of a set number of bits to replace a preamble field of the existing MDIO frame, so as to indicate the beginning of a new MDIO frame. The data packet address field in the MDIO frame is used to indicate the relative address of one data packet in the slave device **804**; the data packet serial number field is used to indicate the location of one data packet in multiple data packets.

Particularly, in the process of transmitting the data packets in batches to the slave device **804** by using the MDIO frame, the acquiring module **8026** of the master device **802** reads download status register information of the slave device **804** by using the MDIO command. The executing module **8028** judges whether the slave device **804** receives the previous group of data packets normally according to the download status register information. If so, a new group of data packets start to be downloaded in batches; otherwise, the slave device **804** is forced to stop the batch download. In addition, in the process of transmitting the data packets in batches to the slave device **804** by using the MDIO frame, if an abnormality

occurs in the master device **802** or the slave device **804** and when the batch download of the data packets is not stopped, the setting module **8030** of the master device **802** sets the value of the data packet address field or the data packet serial number field of the MDIO frame to indicate the slave device **804** to stop the batch download of the data packets.

The slave device **804** receives the data packets transmitted by the master device **802**. When the judging module **8042** judges that a received data packet is the last data packet of the current batch transmission from the master device **802**, the stopping module **8044** informs the slave device **804** of finishing the current batch download. Preferably, the command receiving module of the judging module **8042** receives the MDIO protocol command transmitted by the master device **802**, and acquires the serial numbers of the data packets transmitted in batches by the master device **802** to the slave device **804**. The serial number judging module judges according to a serial number that a received data packet is the last data packet of the current batch transmission from the master device **802**. The stopping module **8044** informs the slave device **804** of finishing the current batch download.

Obviously, those skilled in the art shall understand that the above-mentioned modules and steps of the present invention can be realized by using general purpose calculating device, can be integrated in one calculating device or distributed on a network which consists of a plurality of calculating devices. Alternatively, the modules and the steps of the present invention can be realized by using the executable program code of the calculating device. Consequently, they can be stored in the storing device and executed by the calculating device, or they are made into integrated circuit module respectively, or a plurality of modules or steps thereof are made into one integrated circuit module. In this way, the present invention is not restricted to any particular hardware and software combination.

The descriptions above are only the preferable embodiment of the present invention, which are not used to restrict the present invention. For those skilled in the art, the present invention may have various changes and variations. Any amendments, equivalent substitutions, improvements, etc. within the principle of the present invention are all included in the scope of the protection of the present invention.

What is claimed is:

1. A download method based on a Management Data Input/Output (MDIO) interface, comprising:
 - a master device informing a slave device of using the MDIO interface to start downloading data packets in batches;
 - the master device transmitting data packets in batches to the slave device by using an MDIO frame, wherein the MDIO frame comprises: a data packet address field and/or a data packet serial number field, wherein the data packet address field is used to indicate a relative address of one data packet in the slave device, and the data packet serial number field is used to indicate a location of said one data packet in multiple data packets; and
 - the slave device judging that a received data packet is a last data packet of a current batch transmission from the master device, and finishing a current batch download; wherein the step of the master device informing the slave device of using the MDIO interface to start downloading the data packets in batches comprises:
 - the master device informing, through an MDIO protocol command, the slave device of using the MDIO interface to start downloading the data packets in batches, wherein the MDIO protocol command comprises download register information, wherein the download register

11

information comprises serial numbers of the data packets transmitted in batches by the master device to the slave device;

the step of the slave device judging that a received data packet is the last data packet in the data packets transmitted in batches by the master device comprises:

the slave device judging according to a serial number that the received data packet is the last data packet in the data packets transmitted in batches by the master device.

2. The method according to claim 1, wherein the MDIO frame uses an idle field of a set number of bits to replace a preamble field.

3. The method according to claim 2, wherein the step of the master device informing the slave device of using the MDIO interface to start downloading the data packets in batches comprises:

the master device informing, through an MDIO protocol command, the slave device of using the MDIO interface to start downloading the data packets in batches, wherein the MDIO protocol command comprises download register information, wherein the download register information comprises serial numbers of the data packets transmitted in batches by the master device to the slave device;

the step of the slave device judging that a received data packet is the last data packet in the data packets transmitted in batches by the master device comprises:

the slave device judging according to a serial number that the received data packet is the last data packet in the data packets transmitted in batches by the master device.

4. The method according to claim 2, wherein the step of the slave device judging that a received data packet is the last data packet of the current batch transmission from the master device comprises:

the slave device receiving one MDIO frame transmitted by the master device, parsing out a data packet from the MDIO frame, and storing data of the data packet in the slave device according to an address indicated by the data packet address field or according to a serial number indicated by the data packet serial number field; and

the slave device judging that the stored data packet is the last data packet of the current batch transmission from the master device.

5. The method according to claim 2, further comprising: during a process that the master device transmits the data packets in batches to the slave device by using the MDIO frame, the master device reading download status register information of the slave device through an MDIO protocol command;

the master device judging, according to the download status register information, whether the slave device receives a previous group of data packets normally;

if so, starting downloading a new group of data packets in batches; otherwise, forcing the slave device to stop a batch download.

6. The method according to claim 2, further comprising: during a process that the master device transmits the data packets in batches to the slave device by using the MDIO frame, if an abnormality of the master device or the slave device occurs and a batch download of the data packets is not stopped,

the master device setting a value of the data packet address field or the data packet serial number field of the MDIO frame to indicate the slave device to stop the batch download of the data packets.

7. The method according to claim 2, wherein before the step of the master device informing the slave device of using

12

the MDIO interface to start downloading the data packets in batches, the method further comprises:

the master device setting a length of the MDIO frame according to hardware conditions of the slave device.

8. The method according to claim 1, wherein the step of the slave device judging that a received data packet is the last data packet of the current batch transmission from the master device comprises:

the slave device receiving one MDIO frame transmitted by the master device, parsing out a data packet from the MDIO frame, and storing data of the data packet in the slave device according to an address indicated by the data packet address field or according to a serial number indicated by the data packet serial number field; and

the slave device judging that the stored data packet is the last data packet of the current batch transmission from the master device.

9. The method according to claim 1, further comprising: during a process that the master device transmits the data packets in batches to the slave device by using the MDIO frame, if an abnormality of the master device or the slave device occurs and a batch download of the data packets is not stopped,

the master device setting a value of the data packet address field or the data packet serial number field of the MDIO frame to indicate the slave device to stop the batch download of the data packets.

10. The method according to claim 1, wherein before the step of the master device informing the slave device of using the MDIO interface to start downloading the data packets in batches, the method further comprises:

the master device setting a length of the MDIO frame according to hardware conditions of the slave device.

11. The method according to claim 1, further comprising: during a process that the master device transmits the data packets in batches to the slave device by using the MDIO frame, the master device reading download status register information of the slave device through an MDIO protocol command;

the master device judging, according to the download status register information, whether the slave device receives a previous group of data packets normally;

if so, starting downloading a new group of data packets in batches; otherwise, forcing the slave device to stop a batch download.

12. A download system based on an MDIO interface, comprising: a master device and a slave device, wherein the master device comprises:

an informing module, configured to inform the slave device of using the MDIO interface to start downloading data packets in batches; and

a transmitting module, configured to transmit the data packets in batches to the slave device by using an MDIO frame, wherein the MDIO frame comprises: a data packet address field and/or a data packet serial number field, wherein the data packet address field is used to indicate a relative address of one data packet in the slave device, and the data packet serial number field is used to indicate a location of said one data packet in multiple data packets;

the slave device comprises:

a judging module, configured to judge that a received data packet is a last data packet of a current batch transmission from the master device; and

a stopping module, configured to stop a current batch download;

13

wherein the informing module of the master device comprises:

an MDIO command module, configured to: inform, through an MDIO protocol command, the slave device of using the MDIO interface to start downloading the data packets in batches, wherein the MDIO protocol command comprises download register information, wherein the download register information comprises serial numbers of the data packets transmitted in batches by the master device to the slave device;

the judging module of the slave device comprises:

a command receiving module, configured to receive the MDIO protocol command and acquire the serial numbers; and

a serial number judging module, configured to judge according to a serial number that a received data packet is the last data packet of the current batch transmission from the master device.

13. The system according to claim **12**, wherein the MDIO frame uses an idle field of a set number of bits to replace a preamble field.

14. The system according to claim **13**, wherein the informing module of the master device comprises:

an MDIO command module, configured to: inform, through an MDIO protocol command, the slave device of using the MDIO interface to start downloading the data packets in batches, wherein the MDIO protocol command comprises download register information, wherein the download register information comprises serial numbers of the data packets transmitted in batches by the master device to the slave device;

the judging module of the slave device comprises:

a command receiving module, configured to receive the MDIO protocol command and acquire the serial numbers; and

a serial number judging module, configured to judge according to a serial number that a received data packet is the last data packet of the current batch transmission from the master device.

15. The system according to claim **13**, wherein the master device further comprises:

an acquiring module, configured to: during a process of transmitting the data packets in batches to the slave

14

device by using the MDIO frame, read download status register information of the slave device through an MDIO protocol command; and

an executing module, configured to: judge, according to the download status register information, whether the slave device receives a previous group of data packets normally; if so, start downloading a new group of data packets in batches; otherwise, force the slave device to stop a batch download.

16. The system according to claim **13**, wherein the master device further comprises:

a setting module, configured to: during a process of transmitting the data packets in batches to the slave device by using the MDIO frame, if an abnormality of the master device or the slave device occurs and a batch download of the data packets is not stopped, set a value of the data packet address field or the data packet serial number field of the MDIO frame to indicate the slave device to stop the batch download of the data packets.

17. The system according to claim **12**, wherein the master device further comprises:

a setting module, configured to: during a process of transmitting the data packets in batches to the slave device by using the MDIO frame, if an abnormality of the master device or the slave device occurs and a batch download of the data packets is not stopped, set a value of the data packet address field or the data packet serial number field of the MDIO frame to indicate the slave device to stop the batch download of the data packets.

18. The system according to claim **12**, wherein the master device further comprises:

an acquiring module, configured to: during a process of transmitting the data packets in batches to the slave device by using the MDIO frame, read download status register information of the slave device through an MDIO protocol command; and

an executing module, configured to: judge, according to the download status register information, whether the slave device receives a previous group of data packets normally; if so, start downloading a new group of data packets in batches; otherwise, force the slave device to stop a batch download.

* * * * *